

Done's

BLACK & WHITE

DUNGEON OF TERROR #1 ORCS' NEST



www.donesgames.com

Øone's BLACK & WHITE

Welcome

This product line will bring you simple tiles for your favorite RPGs. In each product you will find a whole fantasy location fully fleshed out in miniature-scale tiles with the usual Øone's top-notch customization capabilities. The B&W maps are simple, line art battlemaps you can customize to suit your needs and then print. These tiles are accurate, detailed, inexpensive and no ink-eaters.

In each B&W product you'll find:

- A Referee map detailing a fantasy location
- The whole location broken in US Letter sheets in miniature scale (each sheet contains a 8x10 inches tile)
- A short description of each area of the location with suggested plots

The Rule the Dungeon® Feature

This Øone's exclusive feature allows you to customize the look of your map by adding the furniture, toggle the grid, hide the room numbers and much more.

On the Referee Map, you will find a big "Rule the Dungeon" button. This button will not be printed, so, don't mind if it overlaps something on the map. By clicking on this button some options will be shown, as detailed below. A checkmark will appear beside the options active.

The options available could vary with products, below is a list of the most common options included in B&W products:

- **Text:** toggle room numbers and tile numbers.
- **Tiling:** toggle the page tiling (Referee Map only)
- **Furniture:** toggle furniture
- **Doors:** toggle doors
- **Square/Hex Grid:** toggle square grid and hexagonal grid
- **No Grid:** turn off the grid
- **Black Fill:** toggle the black in the walls
- **Grey Fill:** toggle the grey fill in the walls
- **No Fill:** toggle the white fill in the walls
- **All:** toggle default state/empty state (with just the walls).

Note that the Rule the Dungeon button on the Referee Map controls all the battlemaps at once.

How to Use This Product

Click on the big button of the Referee Map to customize your maps. Once you have obtained the desired appearance (note that room numbers and tiling do not appear on the tiles) simply choose "Print" from the Acrobat menu.

If you need to print only some tiles, simply click on the desired tile on the Referee Map and choose "Print this Tile".

Tips for Printing

The tiles should have enough margins to print without checking the option "fit to page". If your printer has a margin larger than ¼ inch you should check it in order to print the whole tile. This could reduce slightly your tile but it should be easily usable.



Øone Roleplaying Games
www.Øonegames.com
master@Øonegames.com

Øone's Black & White: Dungeon of Terror #1
Orcs'Nest
Product Code: bew004. First edition 05/2009
Design: Mario Barbati
2D drawings: Mario Barbati
Graphics: Ø'Bully
Software Engineer: Anna Fava

All of the content of this book is © by Øone Roleplaying Games. The reproduction or retransmission of any part of this book, without written permission of the copyright holder is expressly forbidden, except for the purpose of reviews. Permission is granted to print this book for personal use only.

Øone's
BLACK & WHITE
LAIR OF THE
BLACK CULT

DETAILED
INEXPENSIVE
CUSTOMIZABLE
NO INK-EATING

www.Øonegames.com

DUNGEON OF TERROR#1

ORCS' NEST

Welcome to **DUNGEON OF TERROR**, the largest dungeon ever tiled!

DUNGEON OF TERROR contains **164** rooms, **8** different zones (each one featured in a single product) and it's broken in **225** customizable tiles.

You can play **DUNGEON OF TERROR** as a whole dungeon or extract your favorite sub-dungeon (or even a single room or encounter area) to suit your campaign. If you're bold, you can lay down a massive **120x150** inches dungeon to play the most extended miniature-scaled dungeon crawl of the history!

The Story

The Dungeon of Terror was in origin an ancient mine, built by a now disappeared dwarven clan. It is said the dungeon was eventually conquered by an evil mage called Infidus the Black.

Infidus was mad, and he enjoyed filling the dungeon with all sort of magical devices and trying all sort of magical experiments. During his reign, no one dared to enter the Dungeon of Terror, since those who entered, never came out.

The dungeon remained unconquered until a single talented assassin managed to get past the dungeon defenses and penetrated the mad mage's sanctuary, down in the last level of the dungeon, killing him in the sleep.

Nobody knows the fate of the assassin. Someone speculates the assassin was crushed by the dungeon defenses while tried getting out, others say he became so rich to buy a whole reign and crowned himself king, some others say the mage became a lich and trapped the assassin for the eternity within the dungeon.

However, after Infidus death, the dungeon became target for new, evil inhabitants. Slowly, monsters moved into the magical halls breaking their defenses and looting their treasures. Most of the chambers remain actually unconquered and are known today as "The Mad Mage Chambers". (Featured in *Dungeon of Terror* #3, #5 and #7)

It is known that a feared orc tribe, worshipping the one-eyed god, dwells in the northernmost part of the dungeon. They are led by a cruel, black-skinned giant orc called Kruedgoor. (Featured in *Dungeon of Terror* #1)

The northwestern part of the dungeon was claimed a brotherhood of assassins. The assassins made there their hideout and perform all sort of evil and illegal activities, including slavery, torture and worse. (Featured in *Dungeon of Terror* #2).

Featuring one of the two entrances to the Dungeon, on the west side you can find an area called The Maze. It is said that the spirit of a powerful minotaur, once enslaved by Infidus, roams this labyrinth. (Featured in *Dungeon of Terror* #4)

Just south of the other entrance on the east side of the dungeon an undead area is found. This is the domain of Alserlak the Lich and of his wife Varlania the Vampiress, said to keep a "secret written in the books". The powerful couple has legions of undead at their orders and rarely other inhabitants of the dungeon dare to enter their rotten halls. (Featured in *Dungeon of Terror* #6)

In the southeast part of the dungeon there are natural cavern, which maybe existed before the dwarven colonization. Occasionally these caverns are visited by a band of smugglers and clandestine brewers who settled there their brewery. It is said the underground lake is also the home of a ferocious aquatic troll. (Featured in *Dungeon of Terror* #8)

Orcs' Nest

Kruedgoor, the giant black-skinned orc is the king of the Fanged Skull orc tribe. The king, backed by a powerful shaman named Rrrrakkg, conquered the northernmost part of the Dungeon of Terror. It took years to navigate the complex and deal with all the magical traps set in the dungeon, but in the end Rrrrakkg and Kruedgoor made it.

Time passed and Rrrrakkg founded his own church devote to the One Eyed God of the orcs. The shaman is rising in power and the once hidden hostility toward the king is now more clear and open. Two powerful factions are rising among the orcs and doom to those who will find themselves in the middle!

Orcs' Nest rooms

38. Hall of the Pillars (tiles #53, 54)
39. Temple of the One-Eyed God (tiles #8, 22, 23, 24, 37, 38, 39)
40. Library of Rrrrakkg (tile #7)
41. Rrrrakkg bedroom (tile #7)
42. Acolytes bedroom (tile #9)
43. Chamber of the Well (tile #10)
44. Trapped Passage (tile #55)
45. Gong (tile #55)
46. Guardpost and Armory (tile #40)
47. Guardpost (tile #56)
48. Empty (tile #57)
49. Spirits storage (tile #57)
50. Larder (tile #58)
51. Kitchen (tiles #43, 58)
52. Bedroom (tile #59)
53. Bedroom (tile #60)
54. Bedroom (tile #45)
55. Bedroom (tile #45)
56. Bedroom (tile #30)
57. Bedroom (tile #30)
58. Bedroom (tile #15)
59. Bedroom (tile #15)
60. Well (tile #14)
61. King's audience chamber (tiles #12, 13)
62. King's council chamber (tiles #27, 28)
63. King's secret treasure room (tile #12)
64. King's guards bedroom (tile #42)
65. King's guards bedroom (tile #42)
66. Beastmasters room (tile #41)
67. Dire wolves food storage (tile #41)
68. Dire wolves food storage (tile #41)
69. Greatfang cage (tile #26)
70. Dire Wolves cage (tile #25)
71. Dire Wolves cage (tile #25)
72. Dire Wolves cage (tile #25)
73. Dire Wolves cage (tile #11)
74. Dire Wolves cage (tile #11)

**Dungeon of Terror #2:
Brotherhood of Assassins**

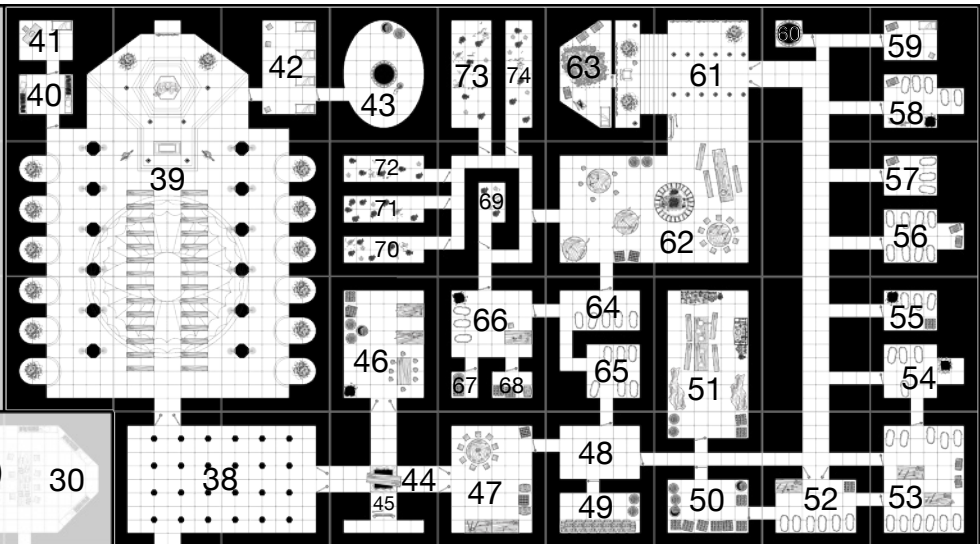
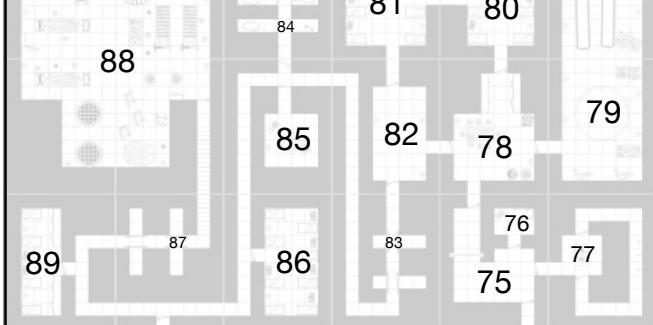

**Dungeon of Terror #5:
Mad Mage Chambers (West)**

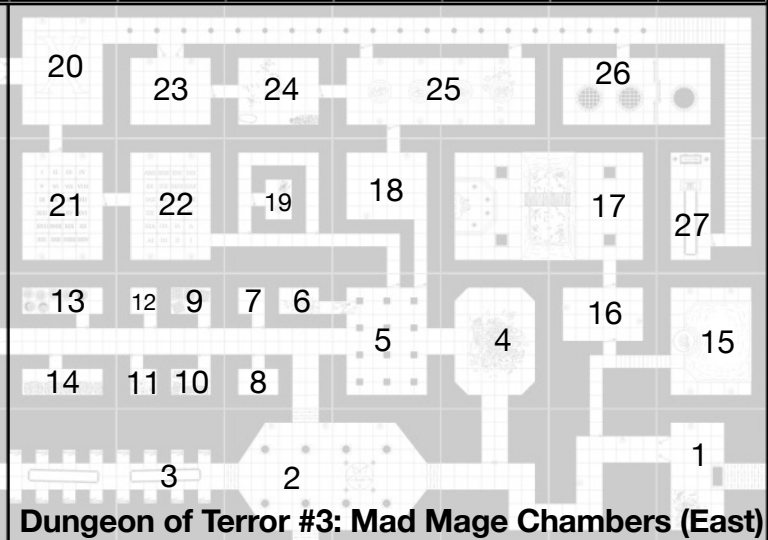
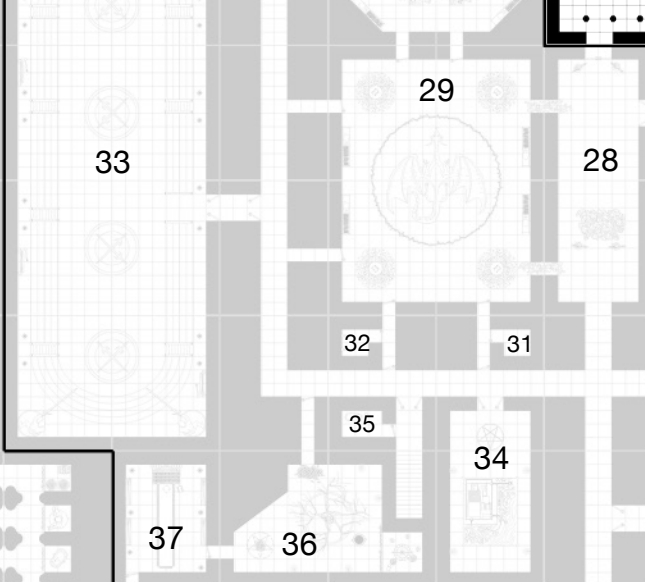

**Dungeon of Terror #4:
The Maze**

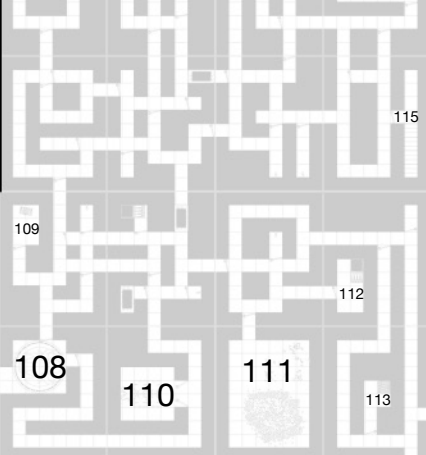

Dungeon of Terror #6: Lord of Undead

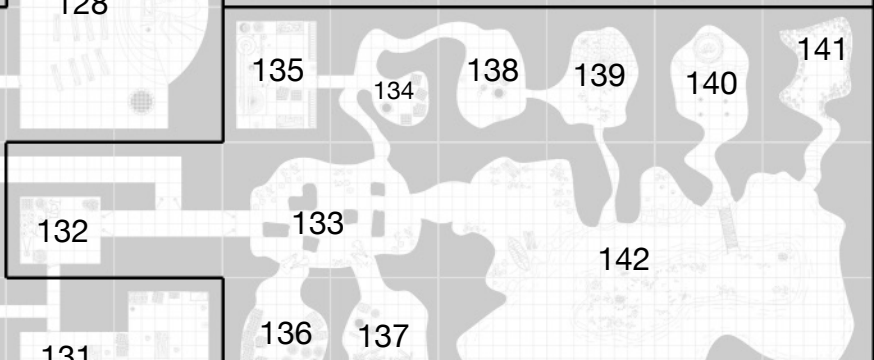
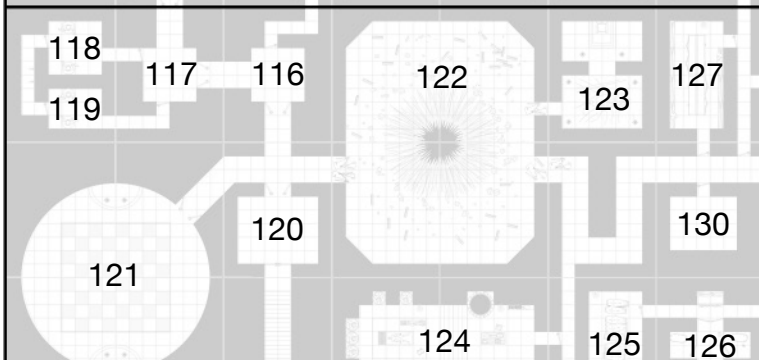
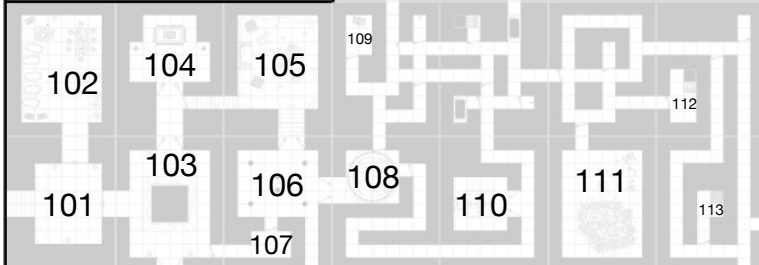
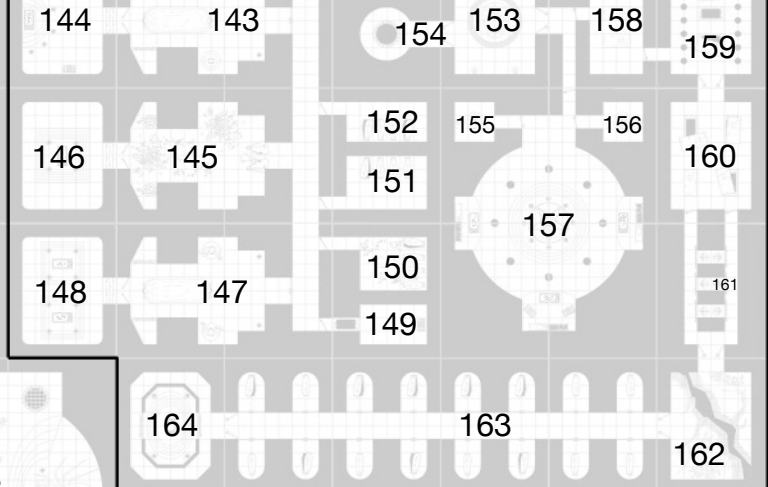

Dungeon of Terror #7: Mad Mage Chambers (South)

Dungeon of Terror #8: Scrag's Caverns

TERROR#7

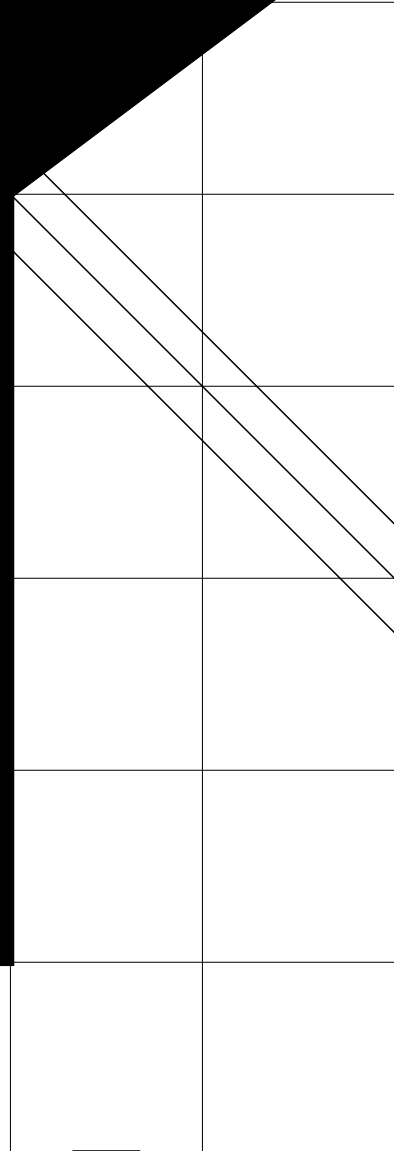
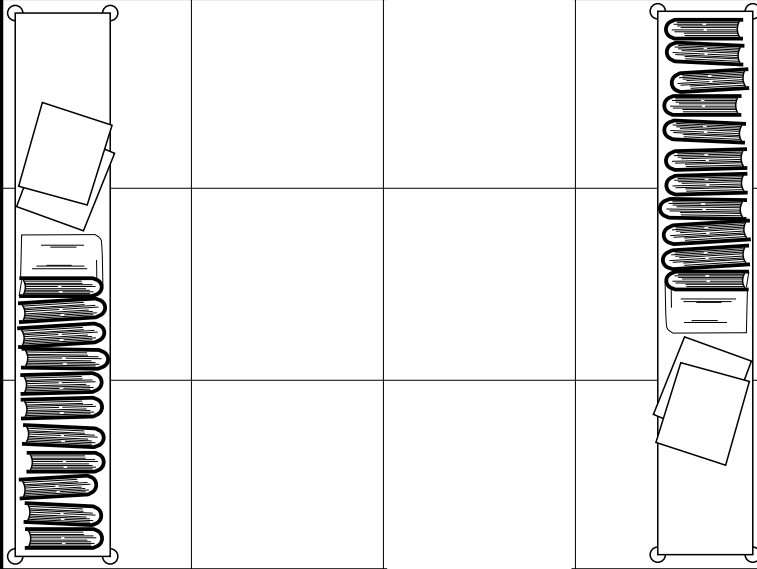
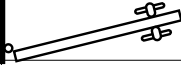
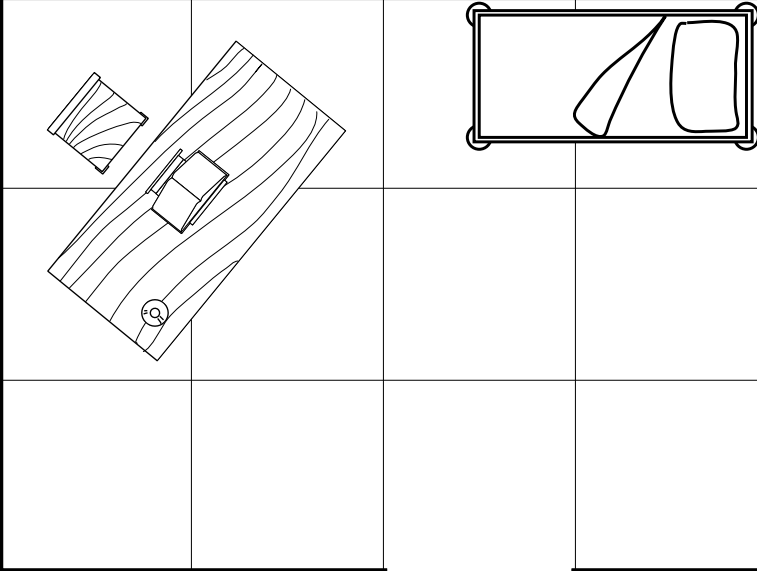

TERROR#8

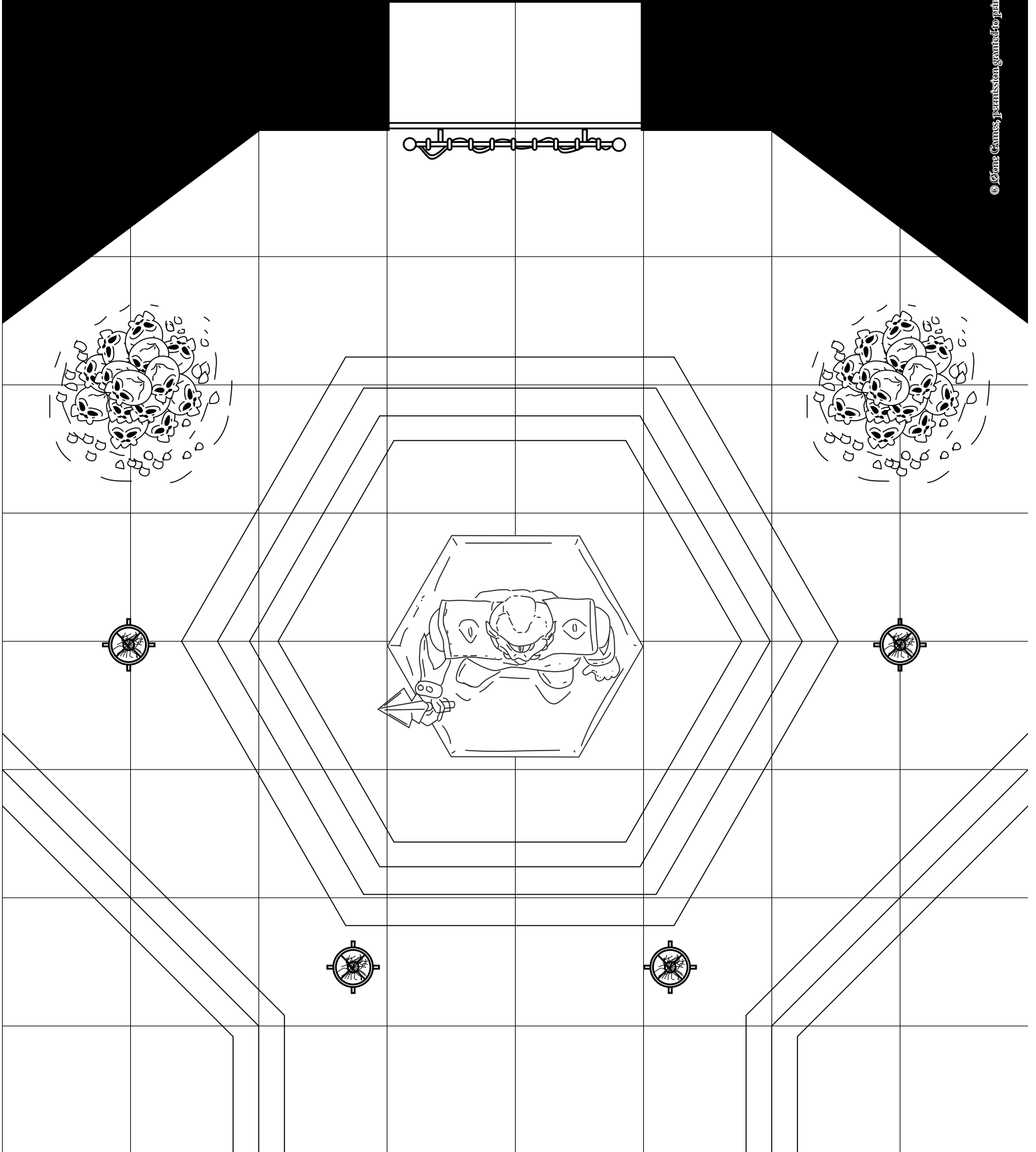

TERROR#9

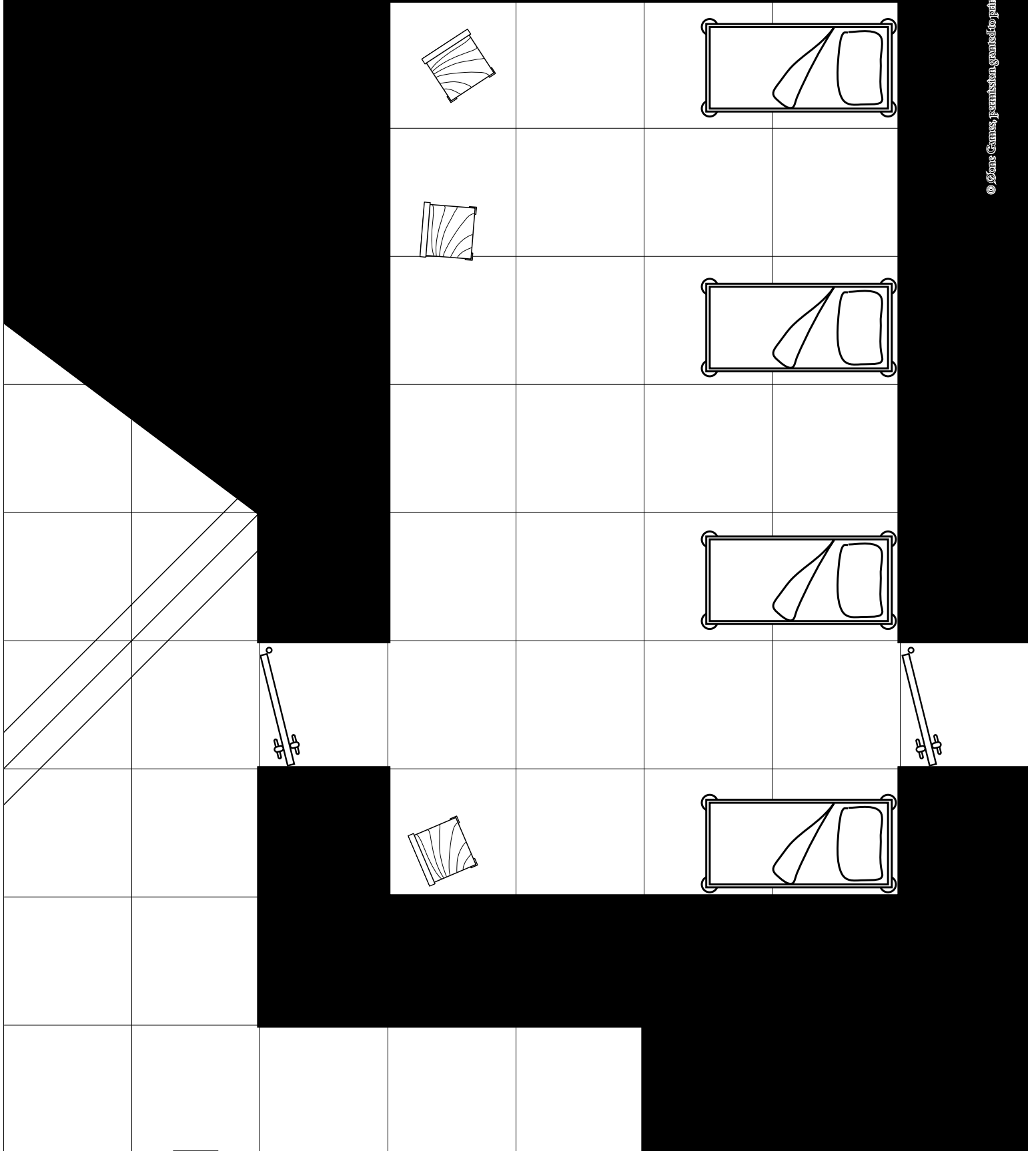

TERROR#10

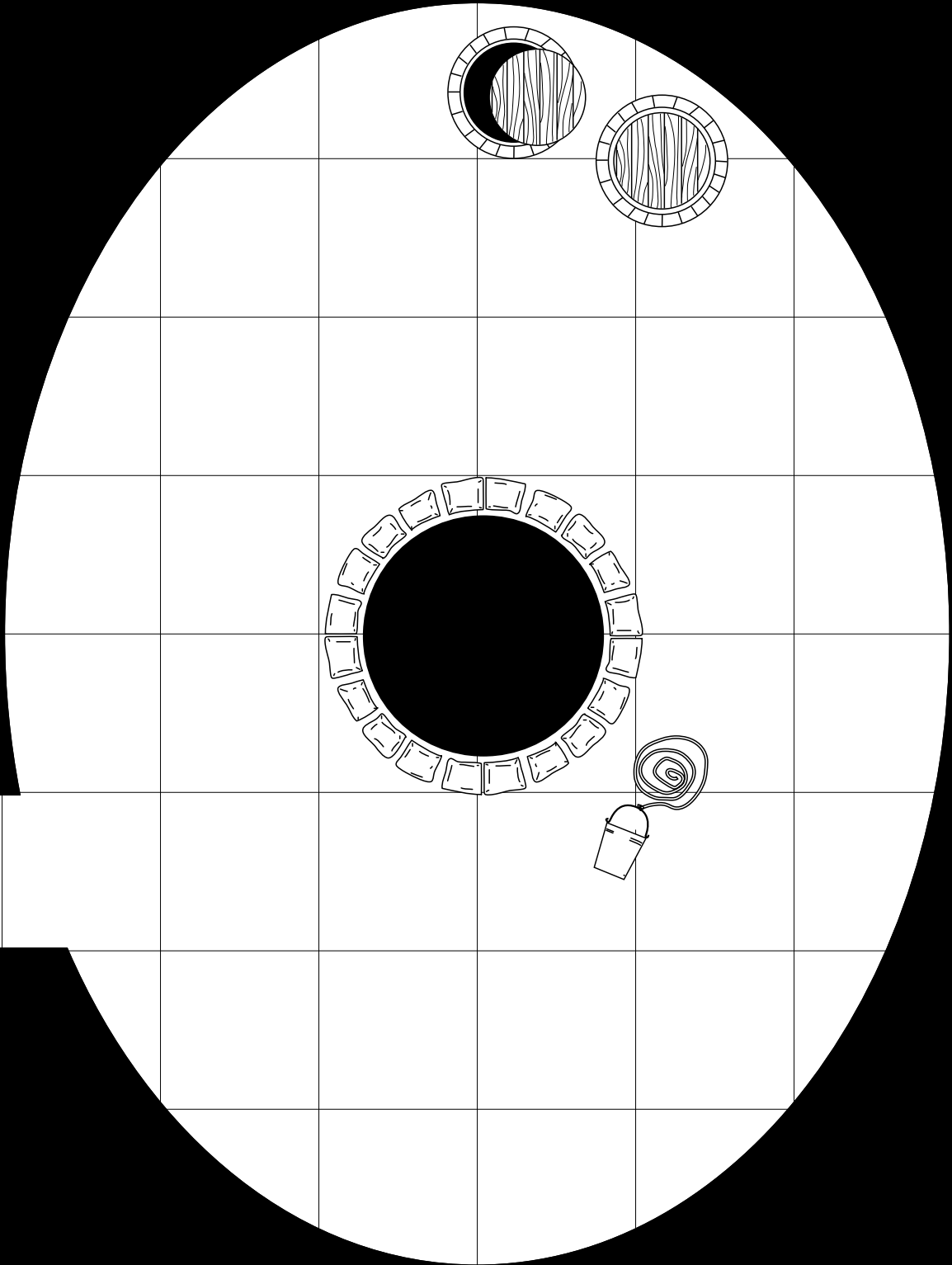

TERROR#11

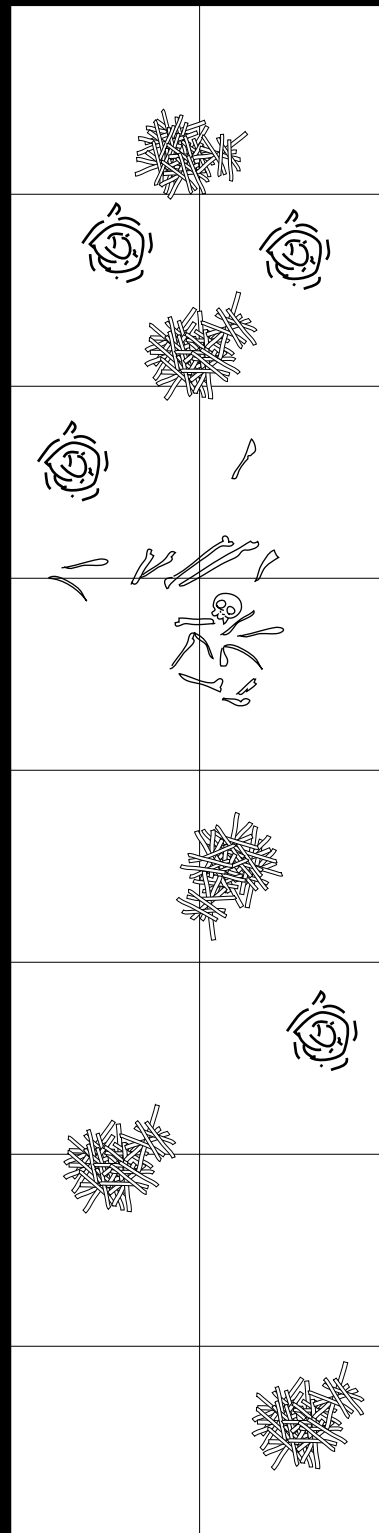
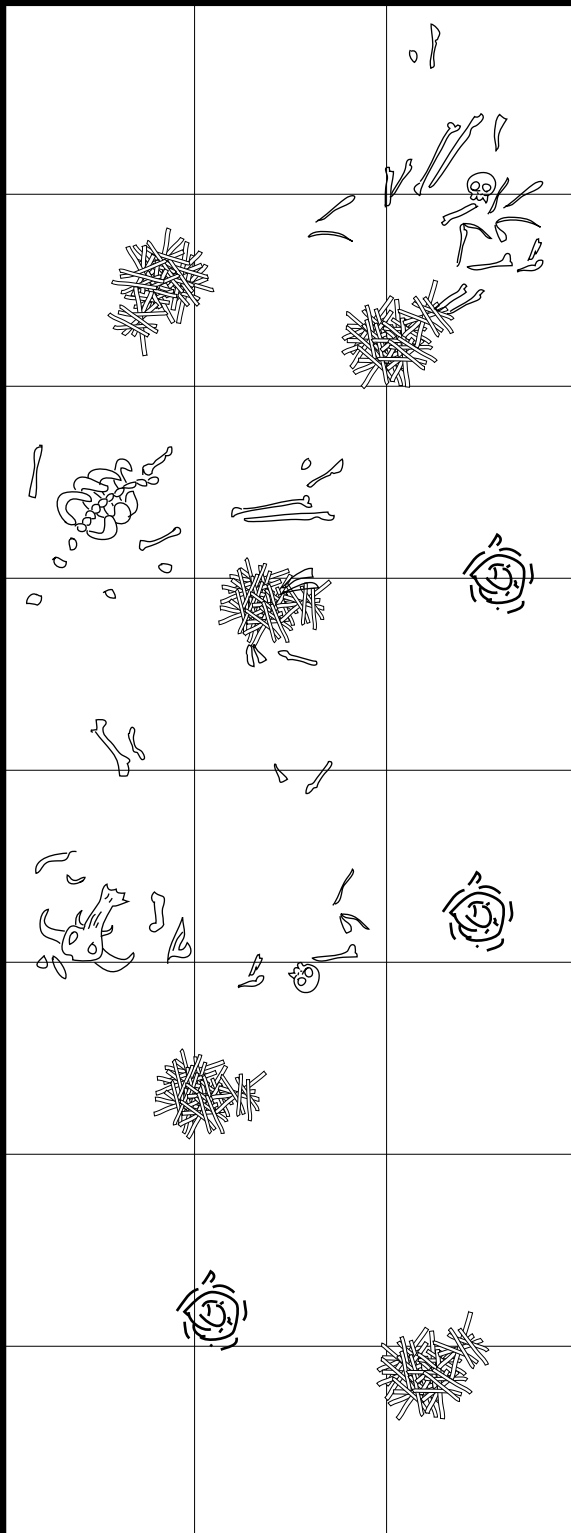

TERROR#12

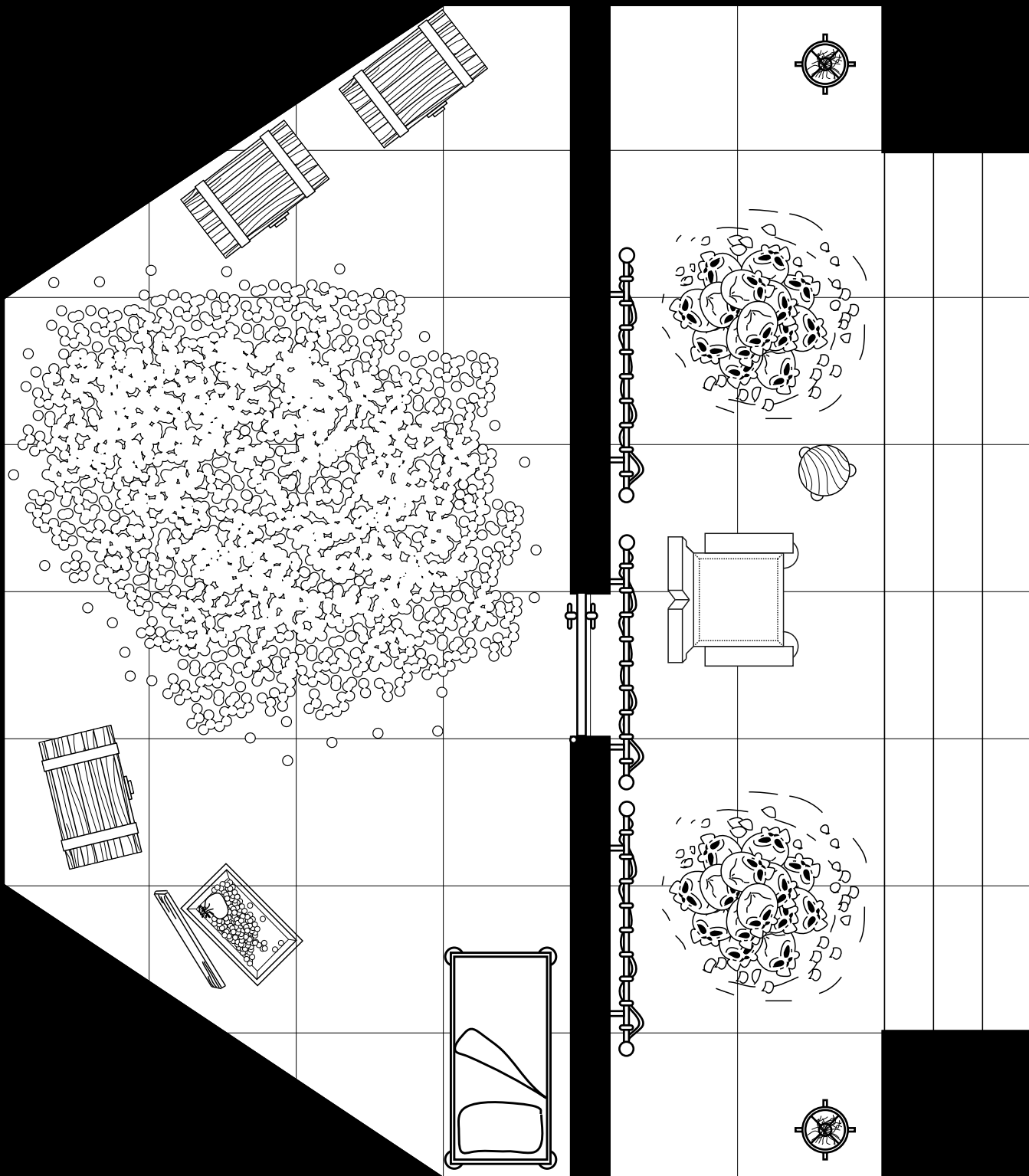

TERROR#13

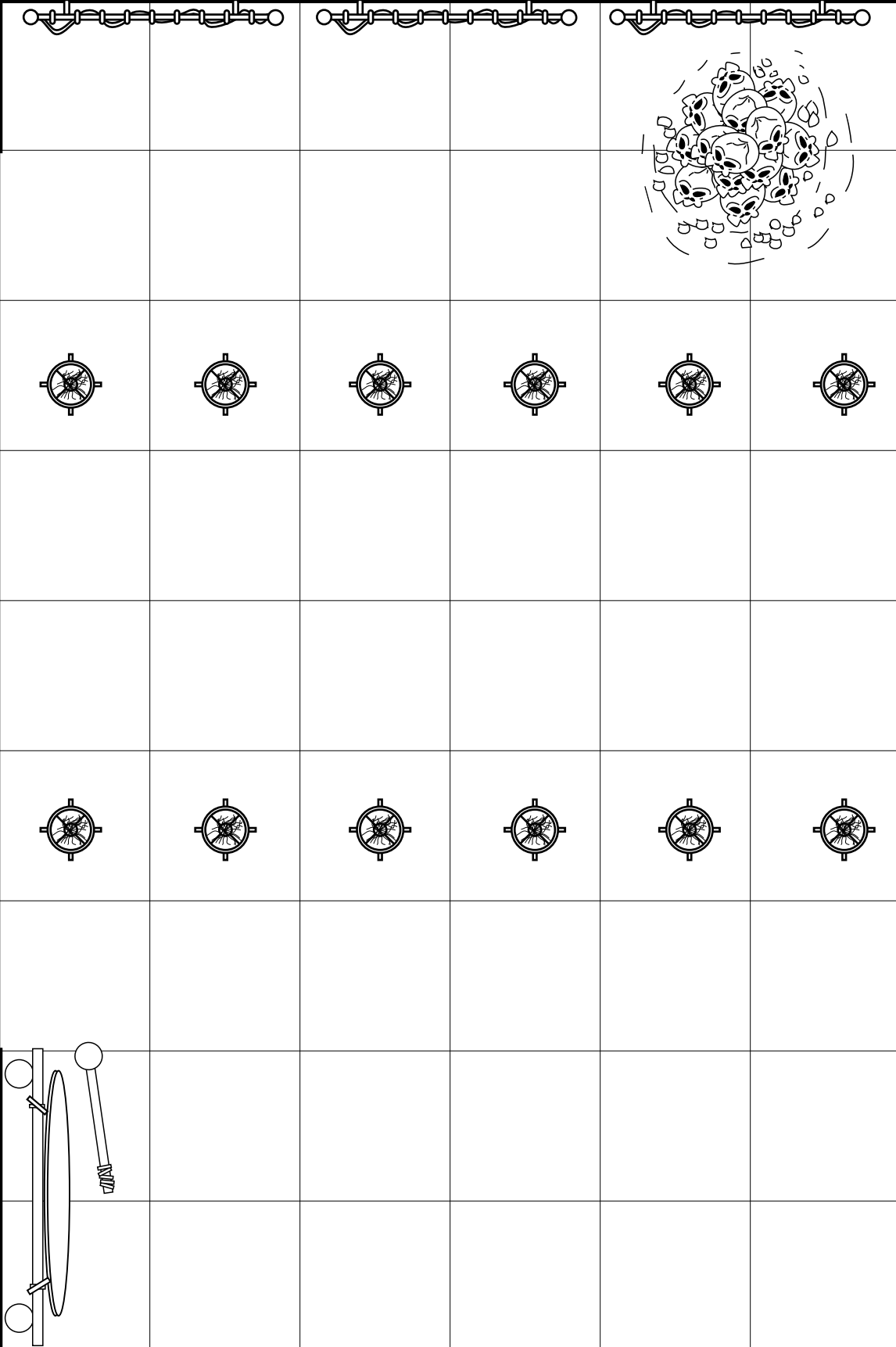

TERROR#14

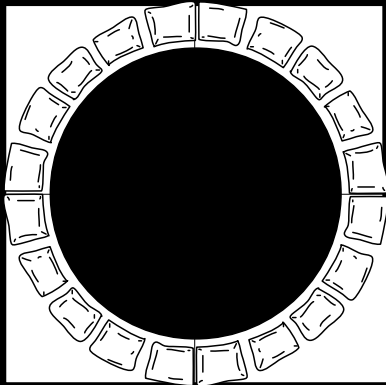

TERROR#15

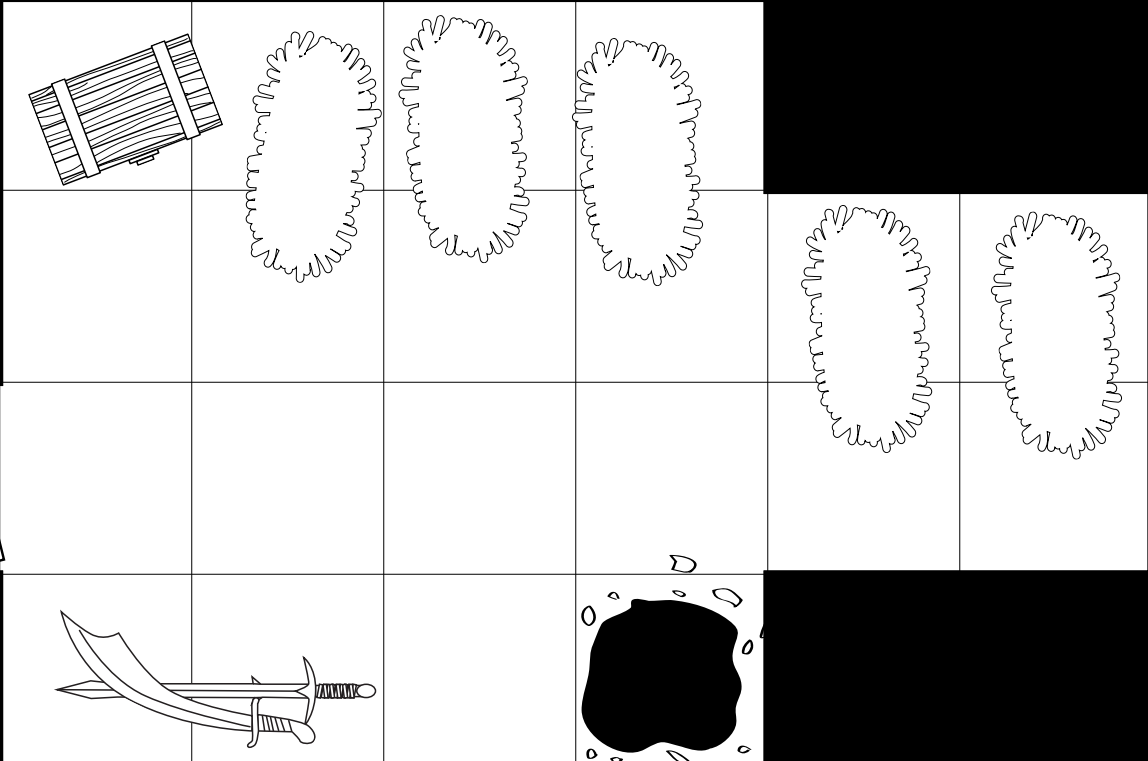
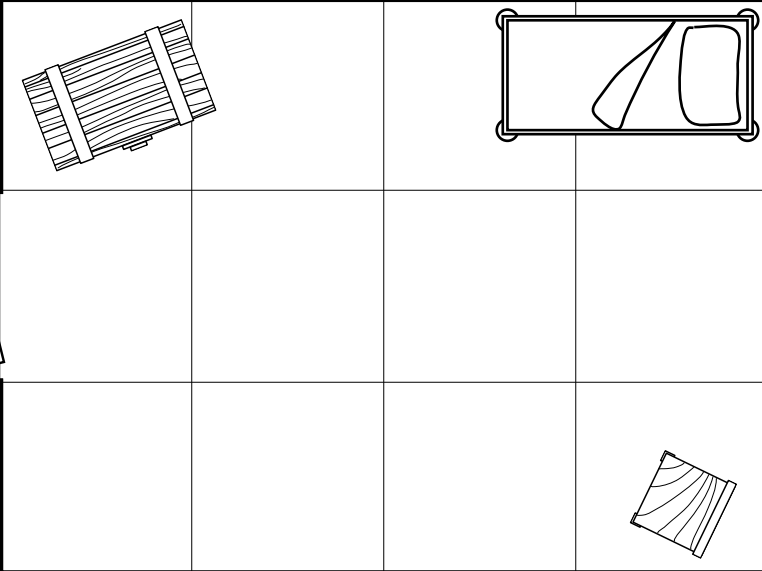

TERROR#22

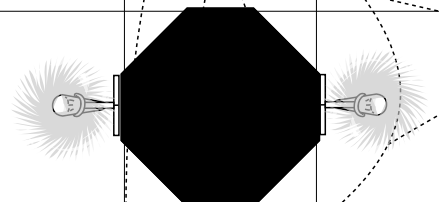
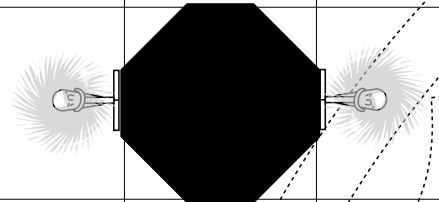
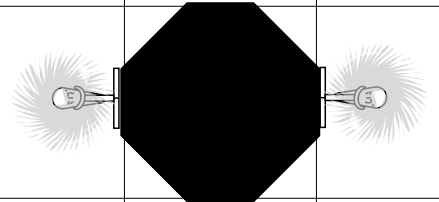
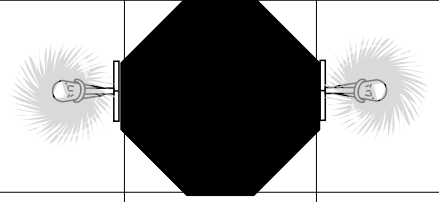
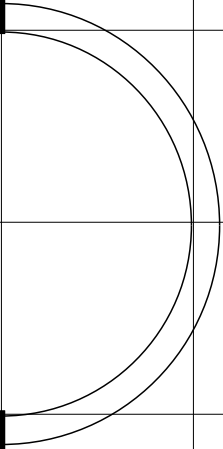
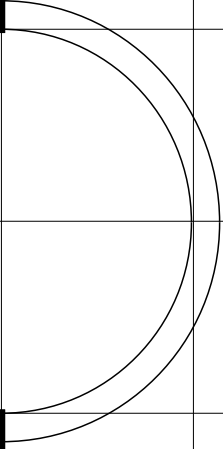
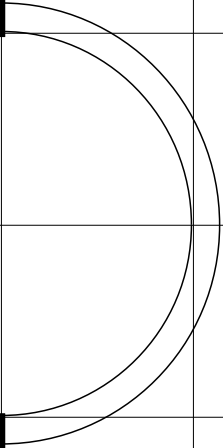
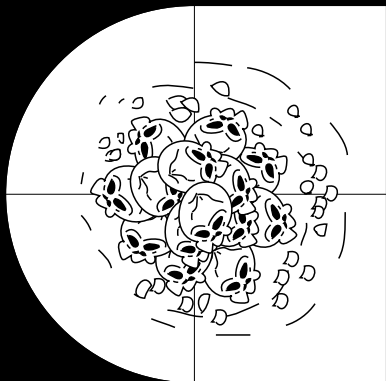
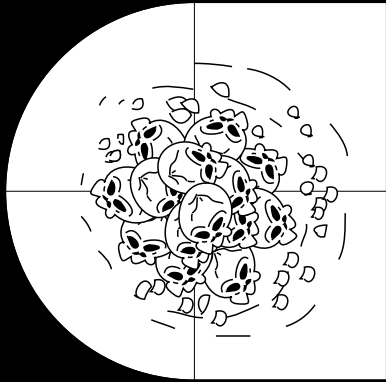

TERROR#23

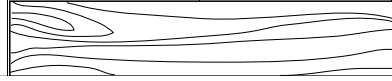
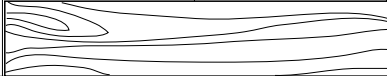
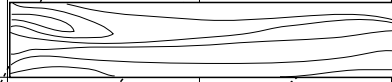
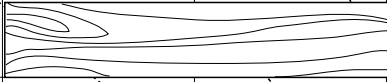
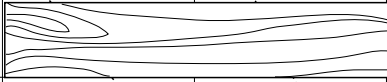
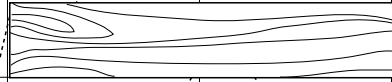
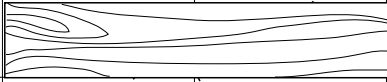
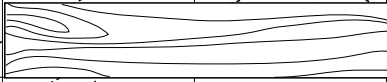
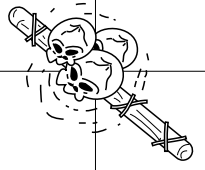
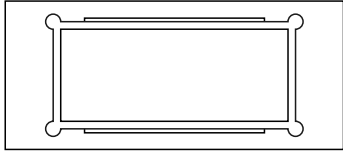
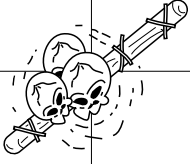

TERROR#24

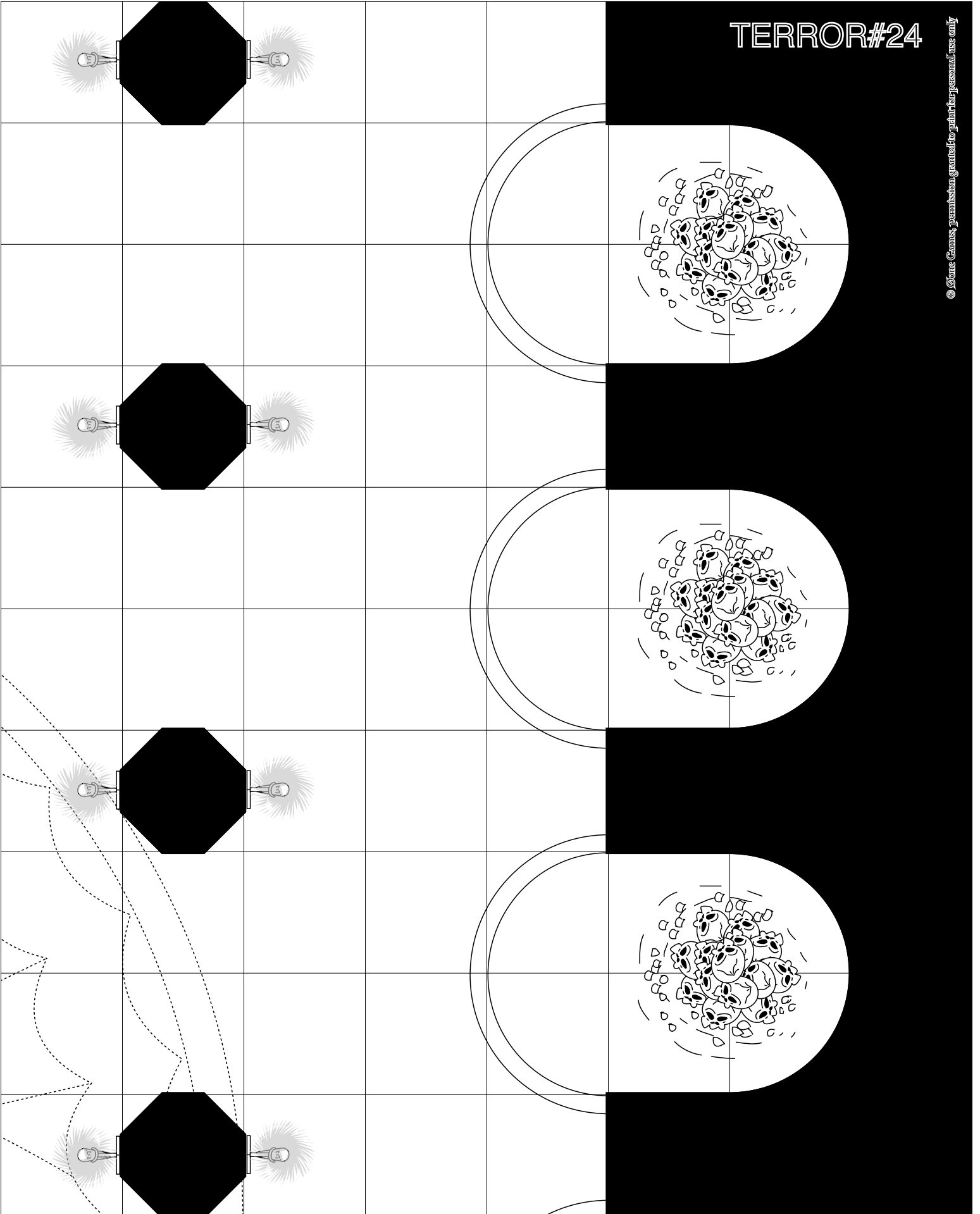

TERROR#25

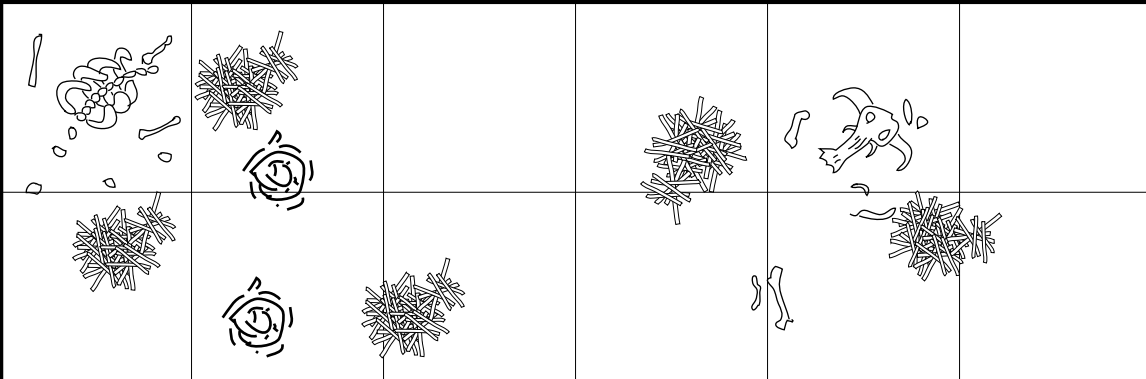
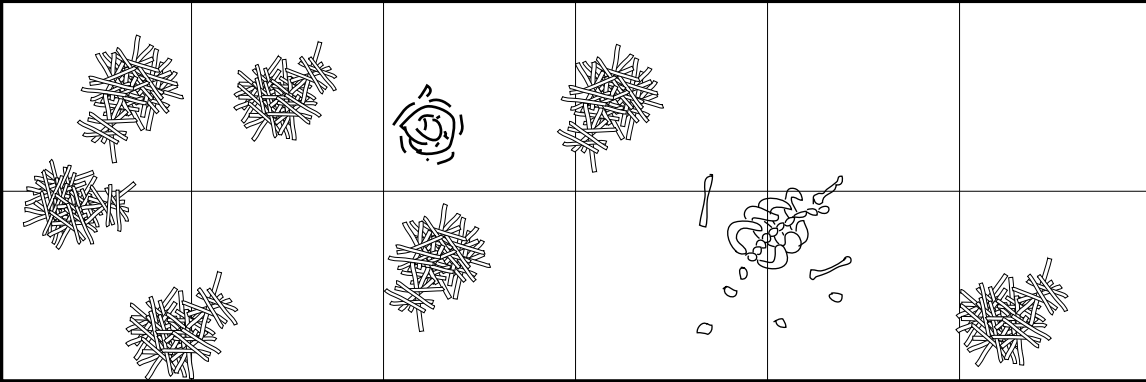
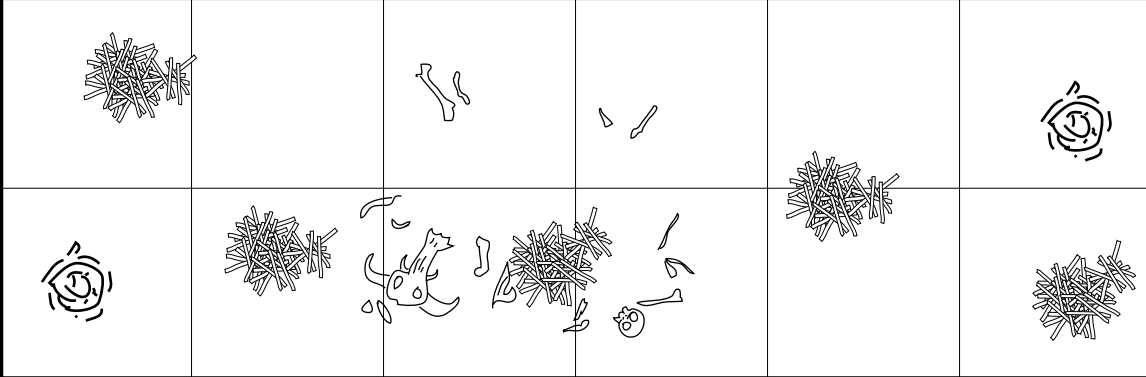

TERROR#26

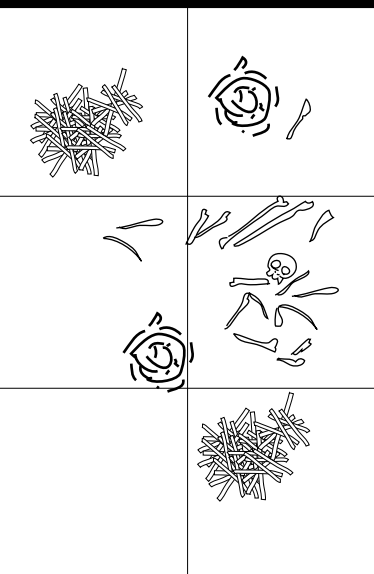
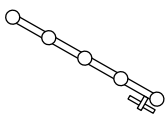
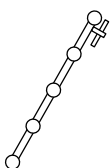
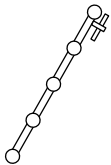
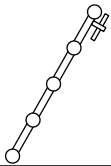
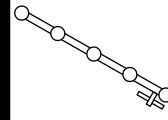
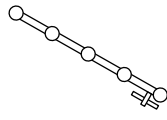

TERROR#27

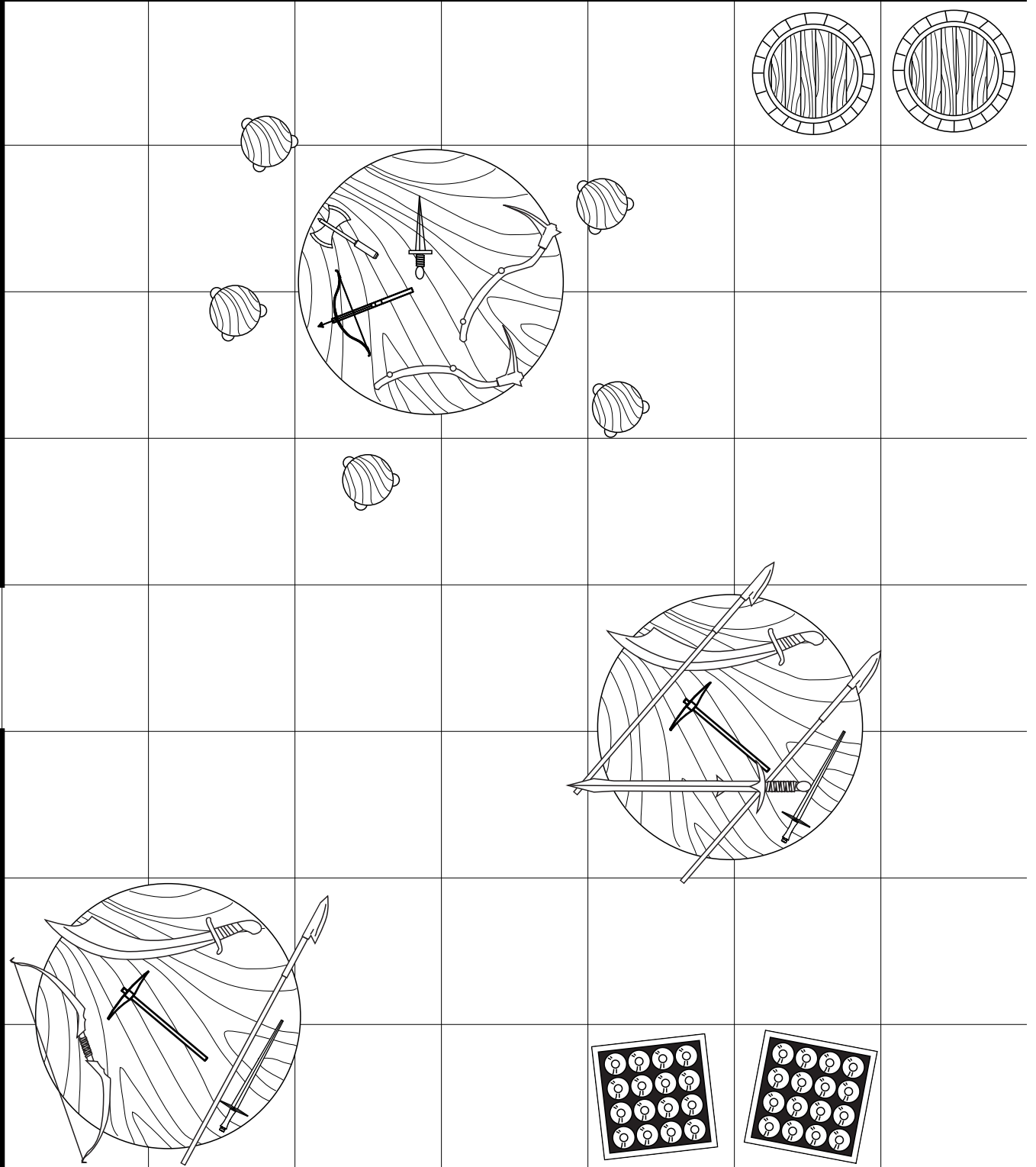

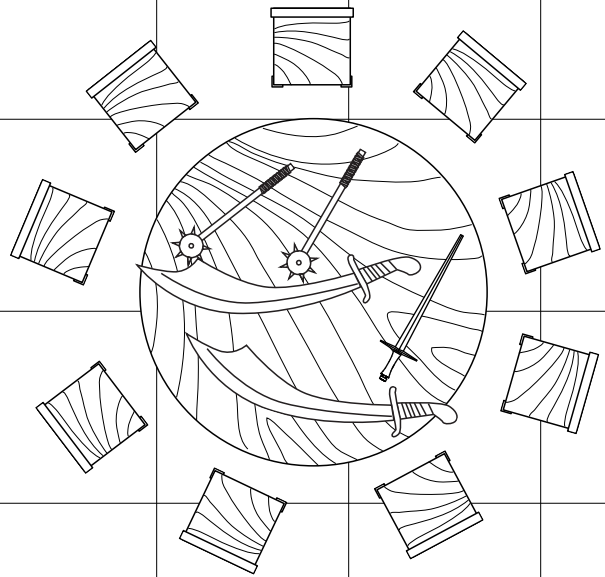
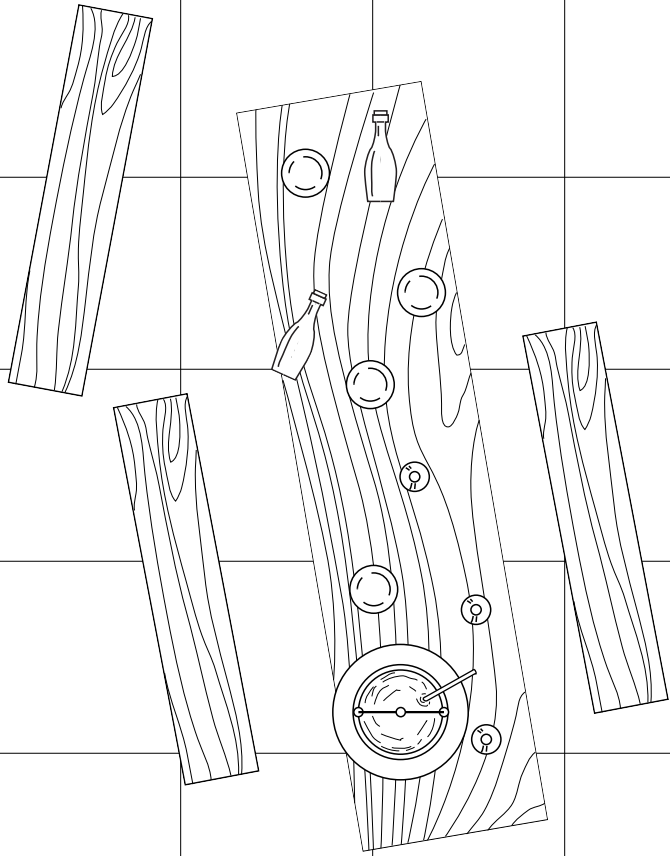
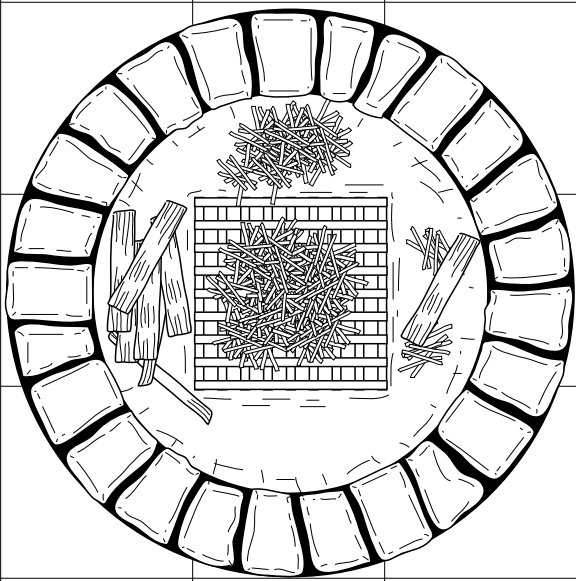

TERROR#29

© 2016 Canvas LMS, Inc. All rights reserved. Canvas LMS is a registered trademark of Canvas LMS, Inc. Canvas LMS is not responsible for any content posted on this site.

TERROR#30

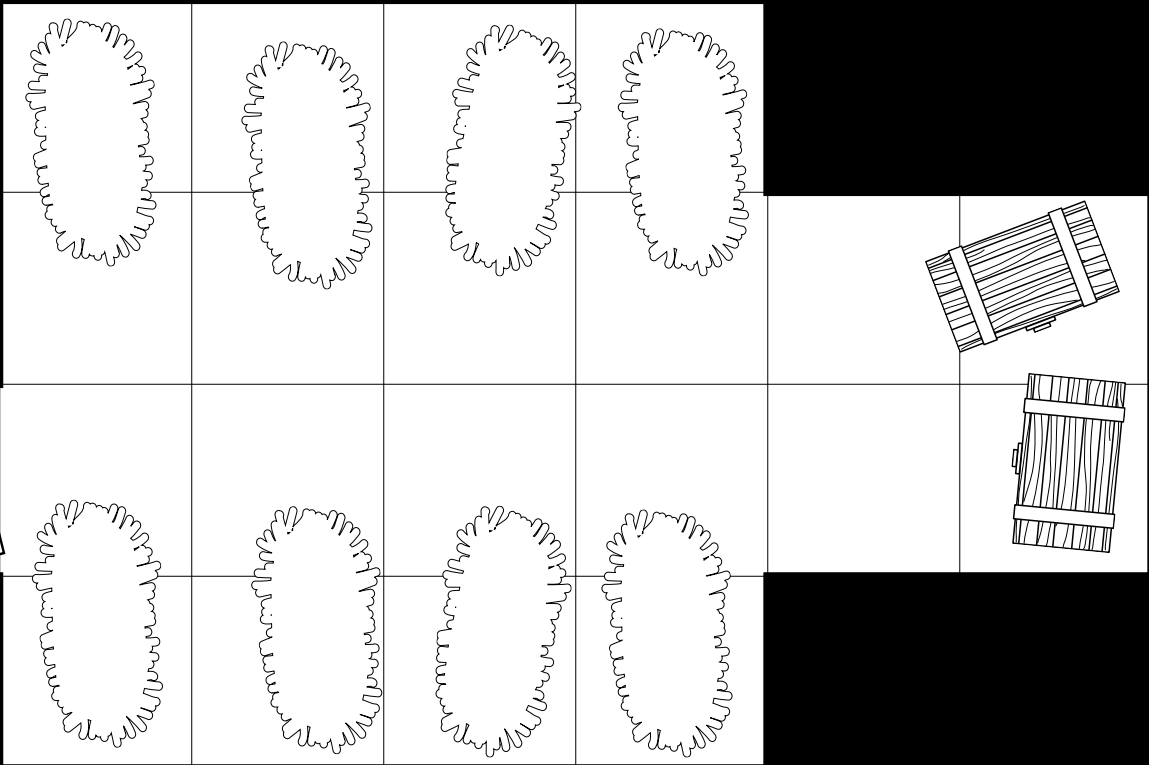
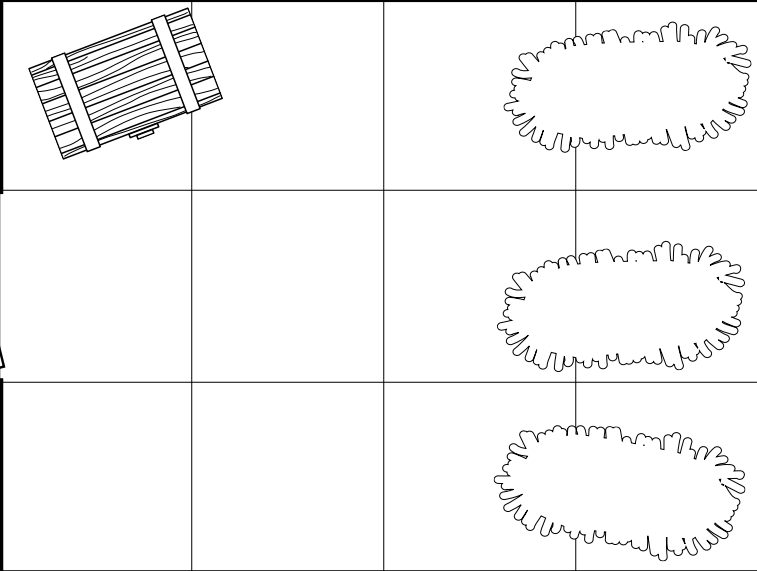

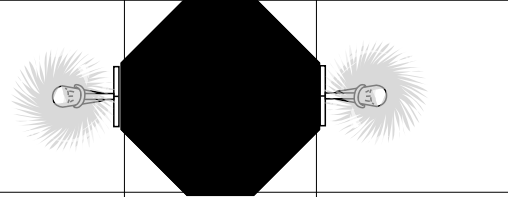
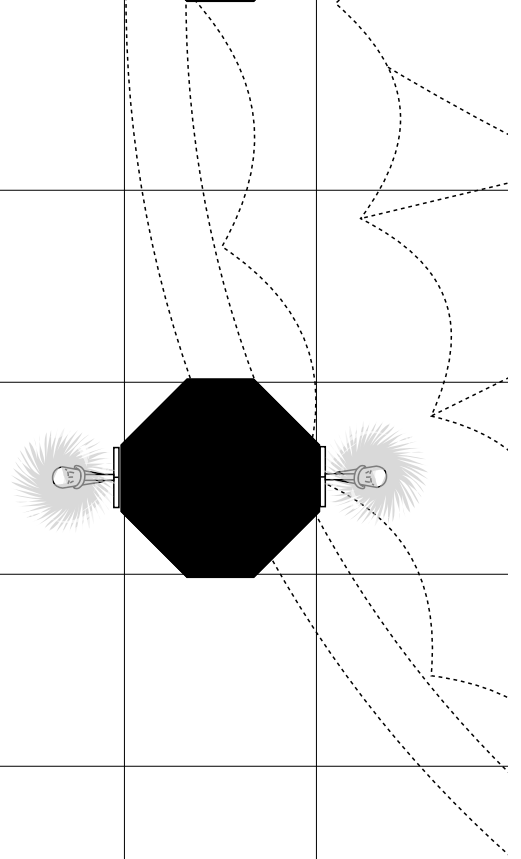
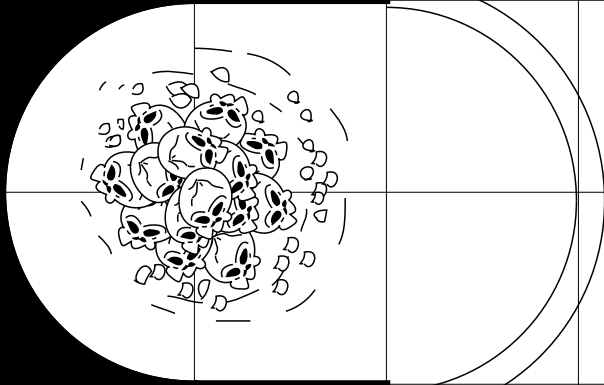
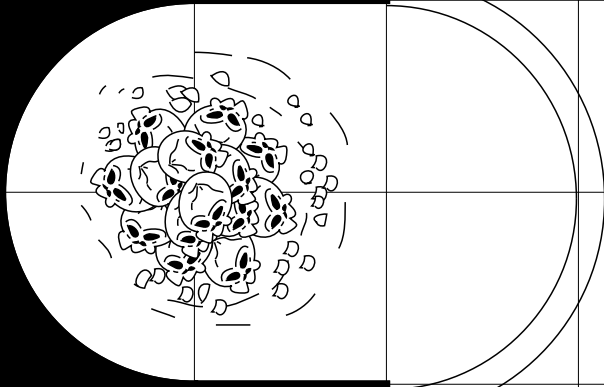
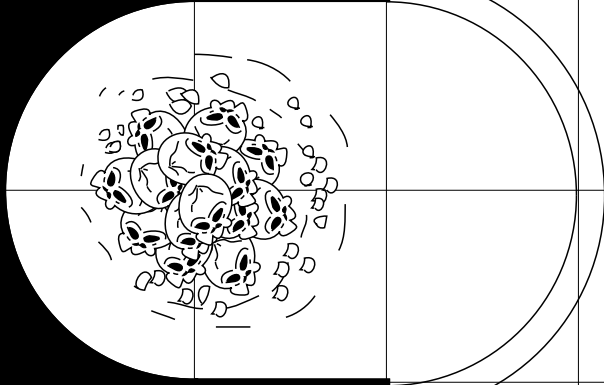

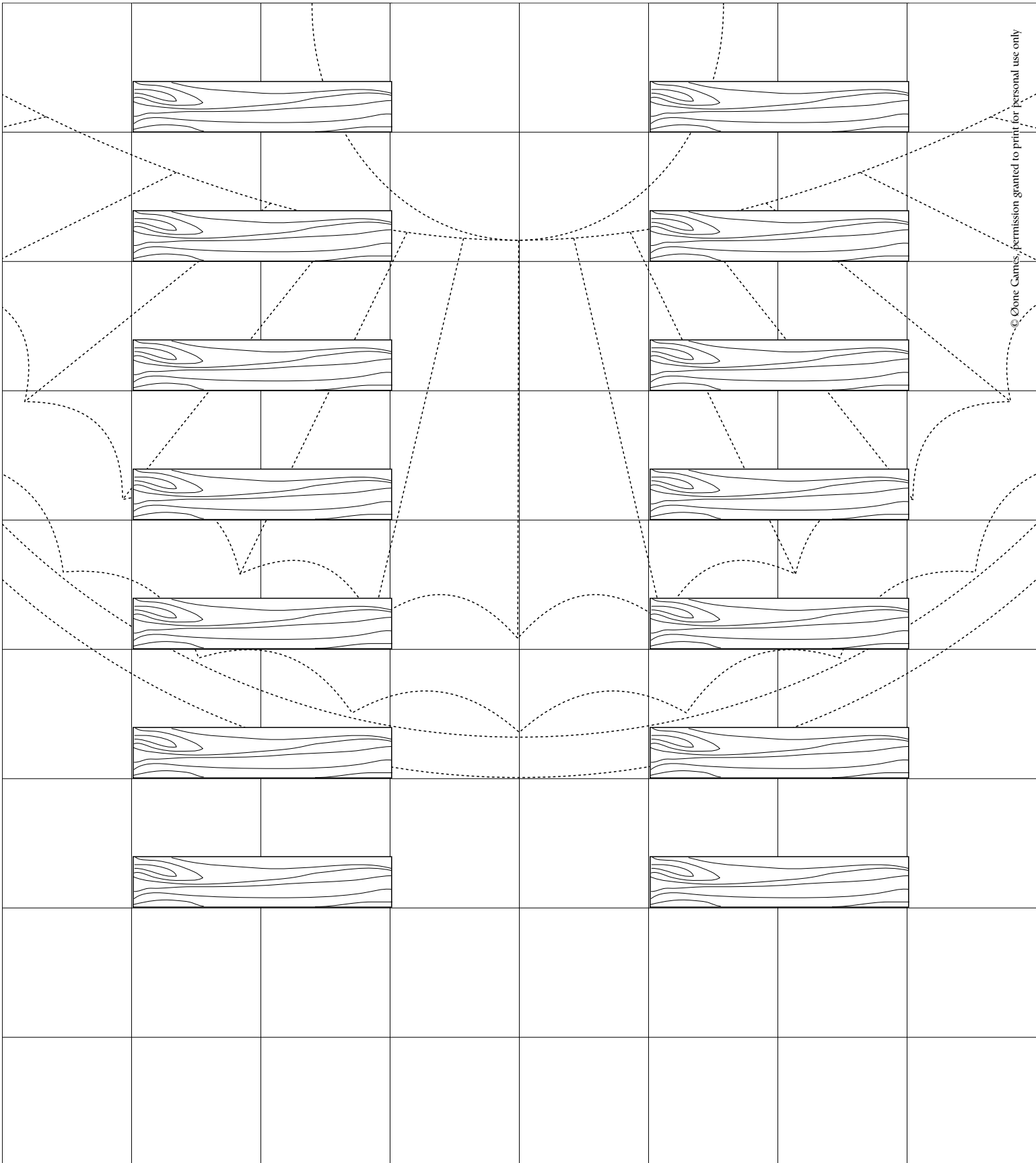

TERROR#38

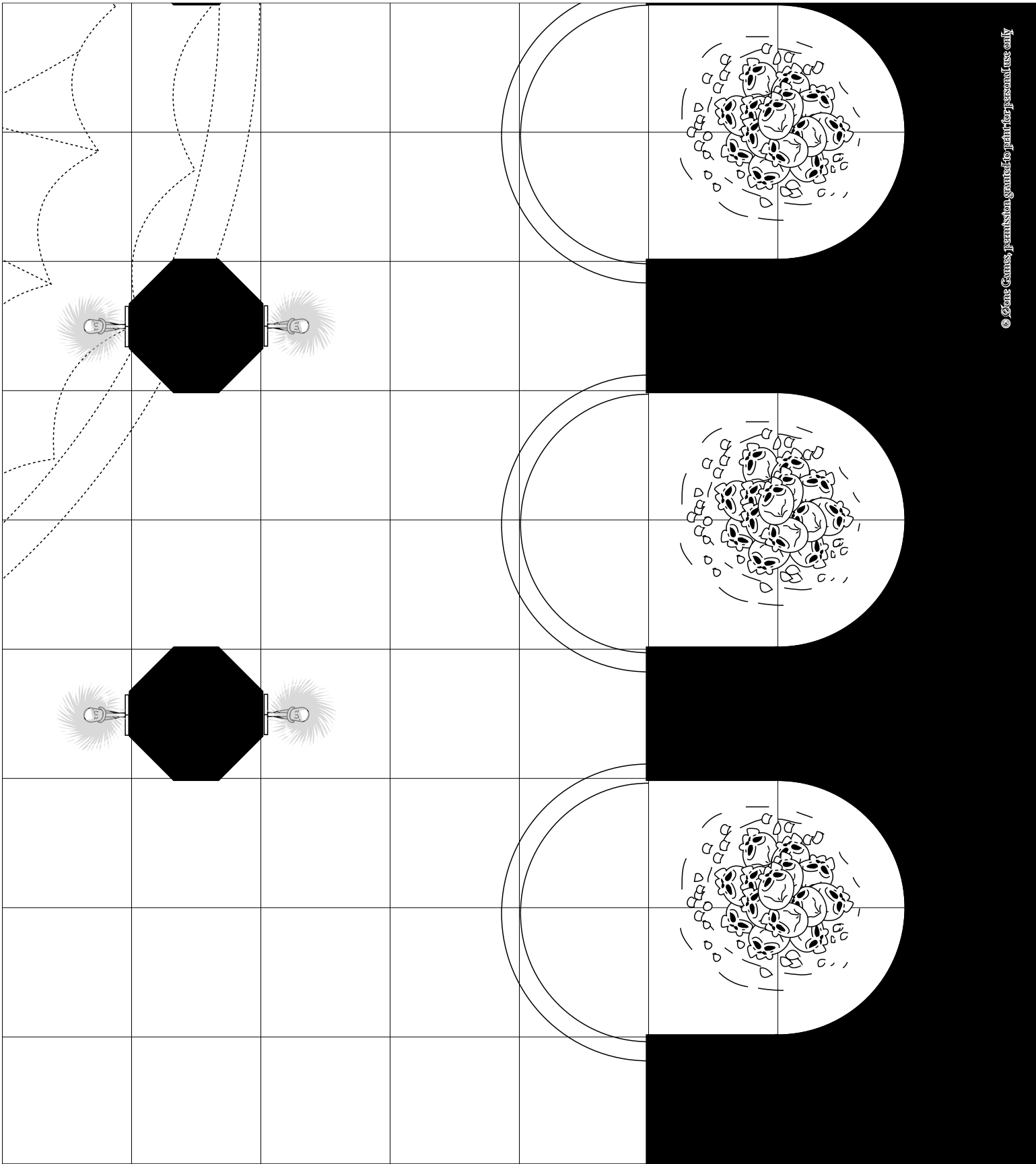

TERROR#39

TERROR#40

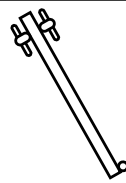
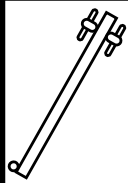
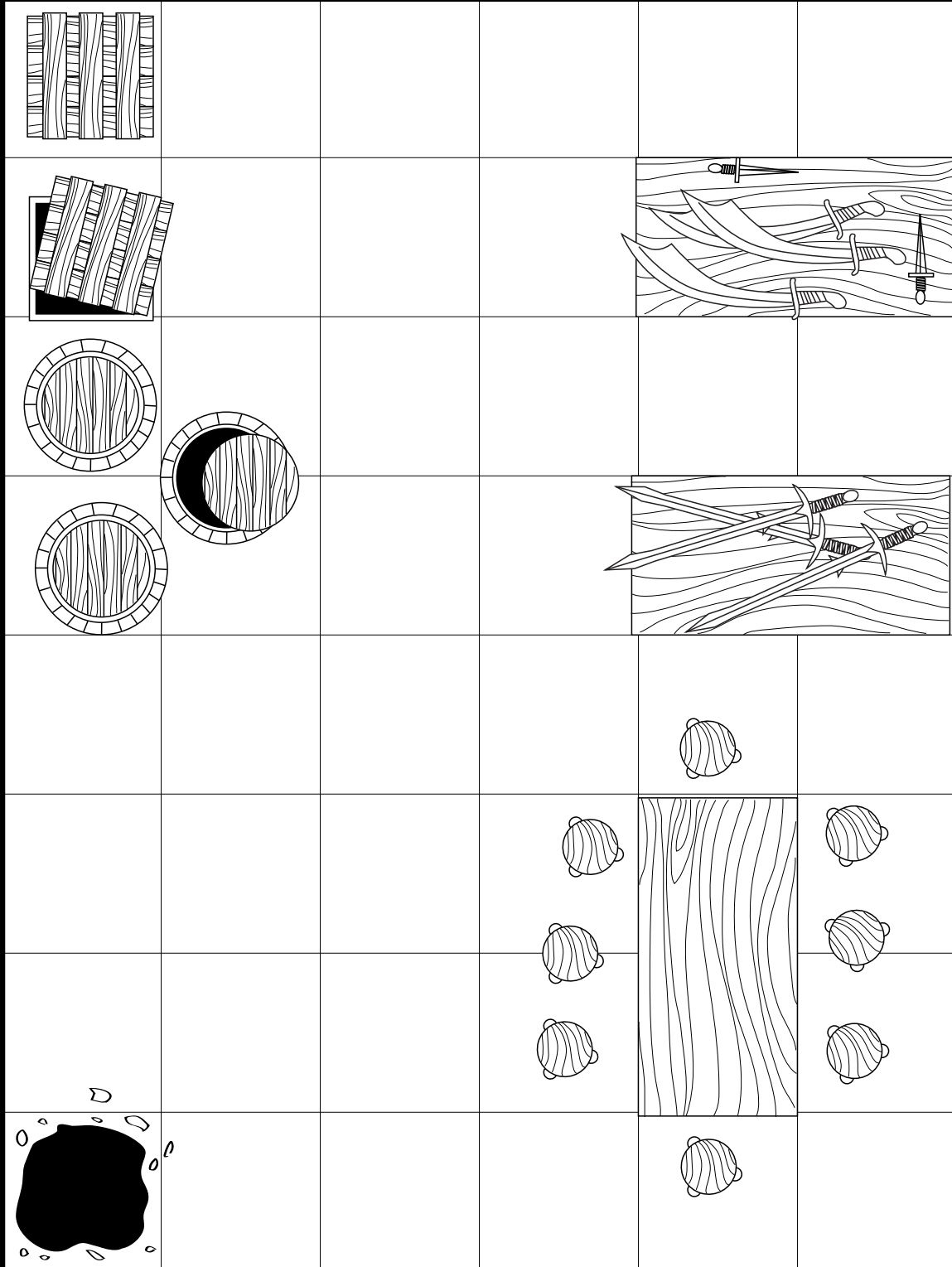

TERROR#41

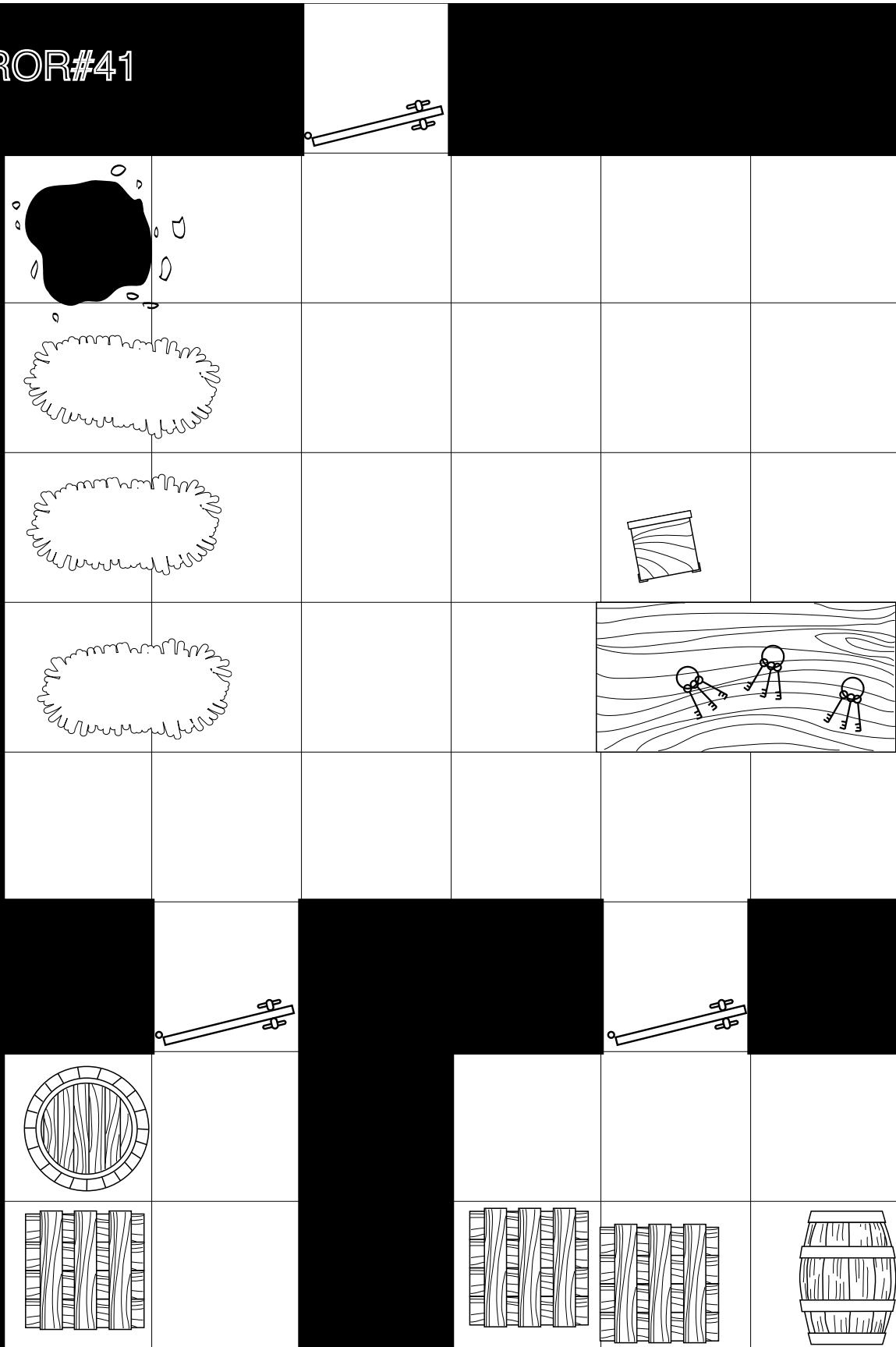

TERROR#42

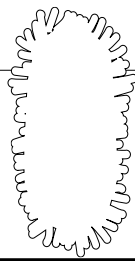
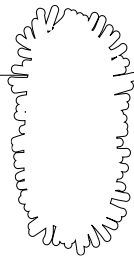
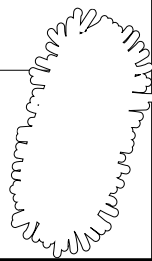
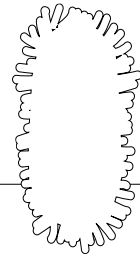
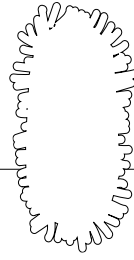
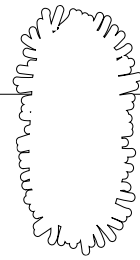
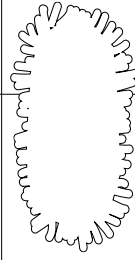
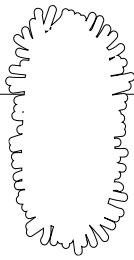
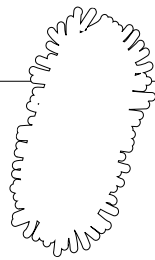
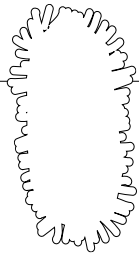
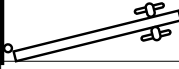

TERROR#43

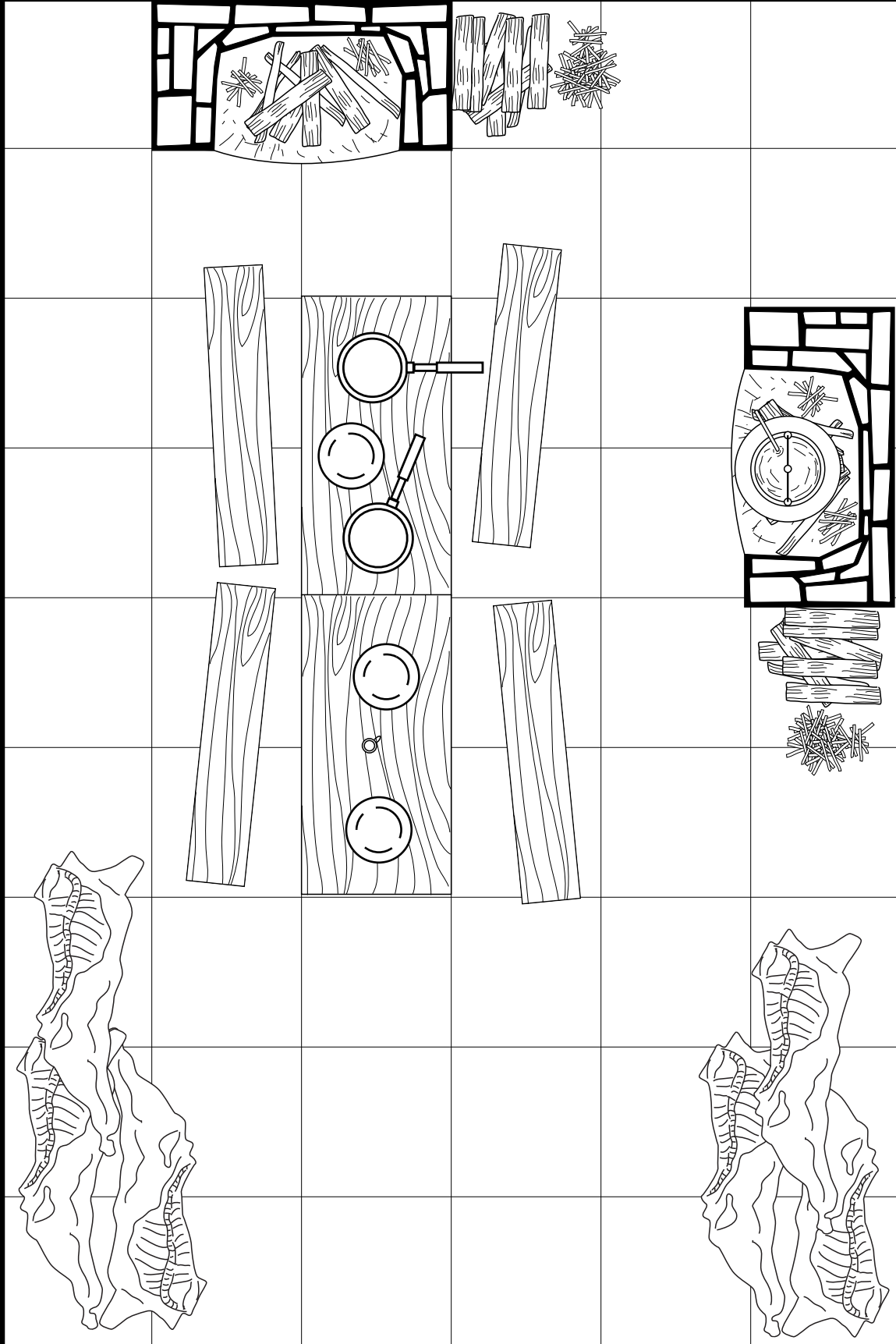

TERROR#44

TERROR#45

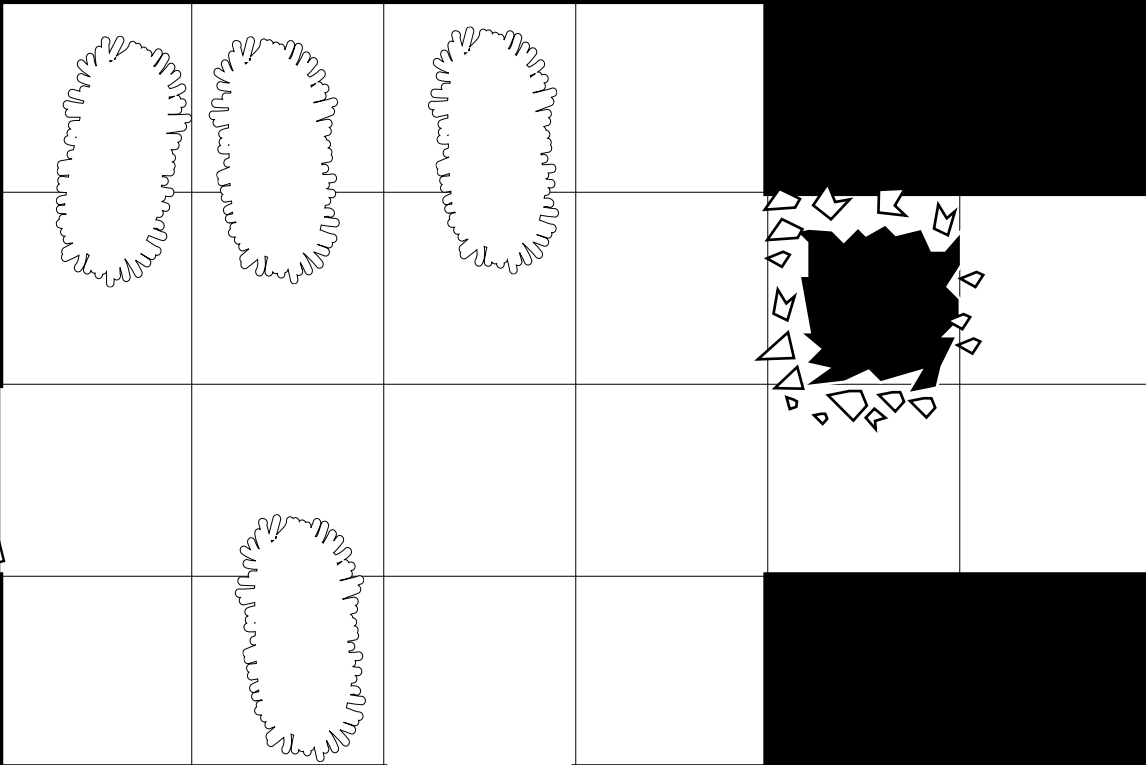
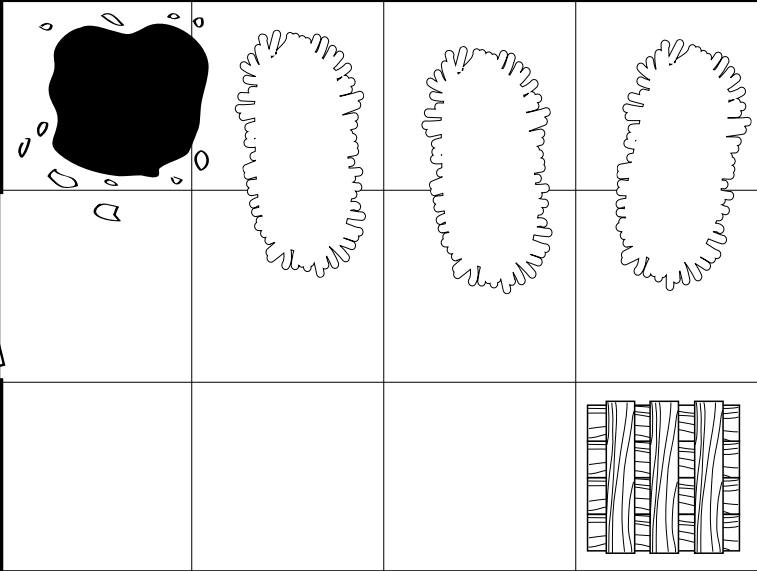

TERROR#53

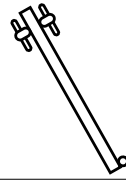
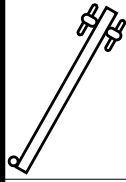

		●		●		●
		●		●		●
		●		●		●
		●		●		●
		●		●		●

TERROR#54

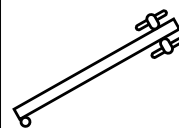
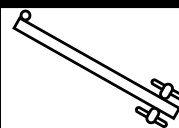
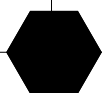
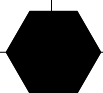
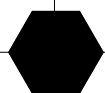
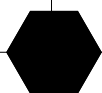
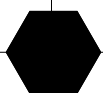
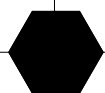
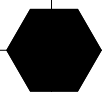
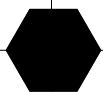
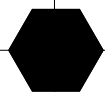
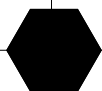
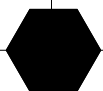
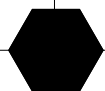

TERROR#55

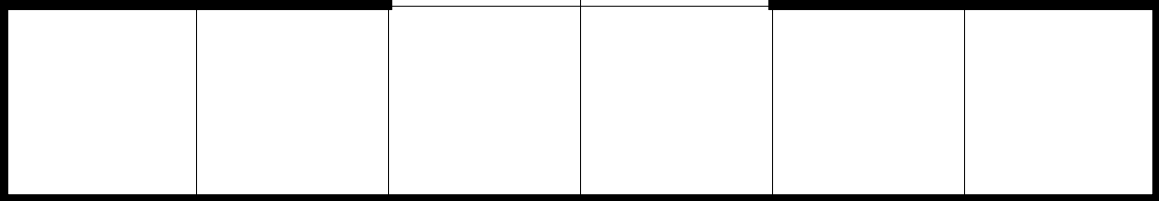
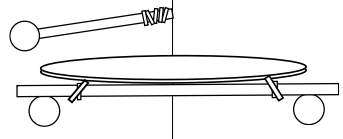
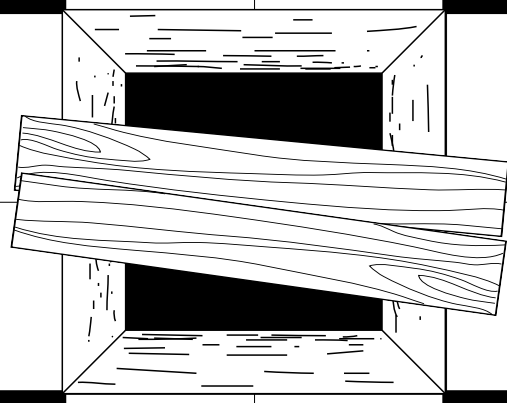

TERROR#56

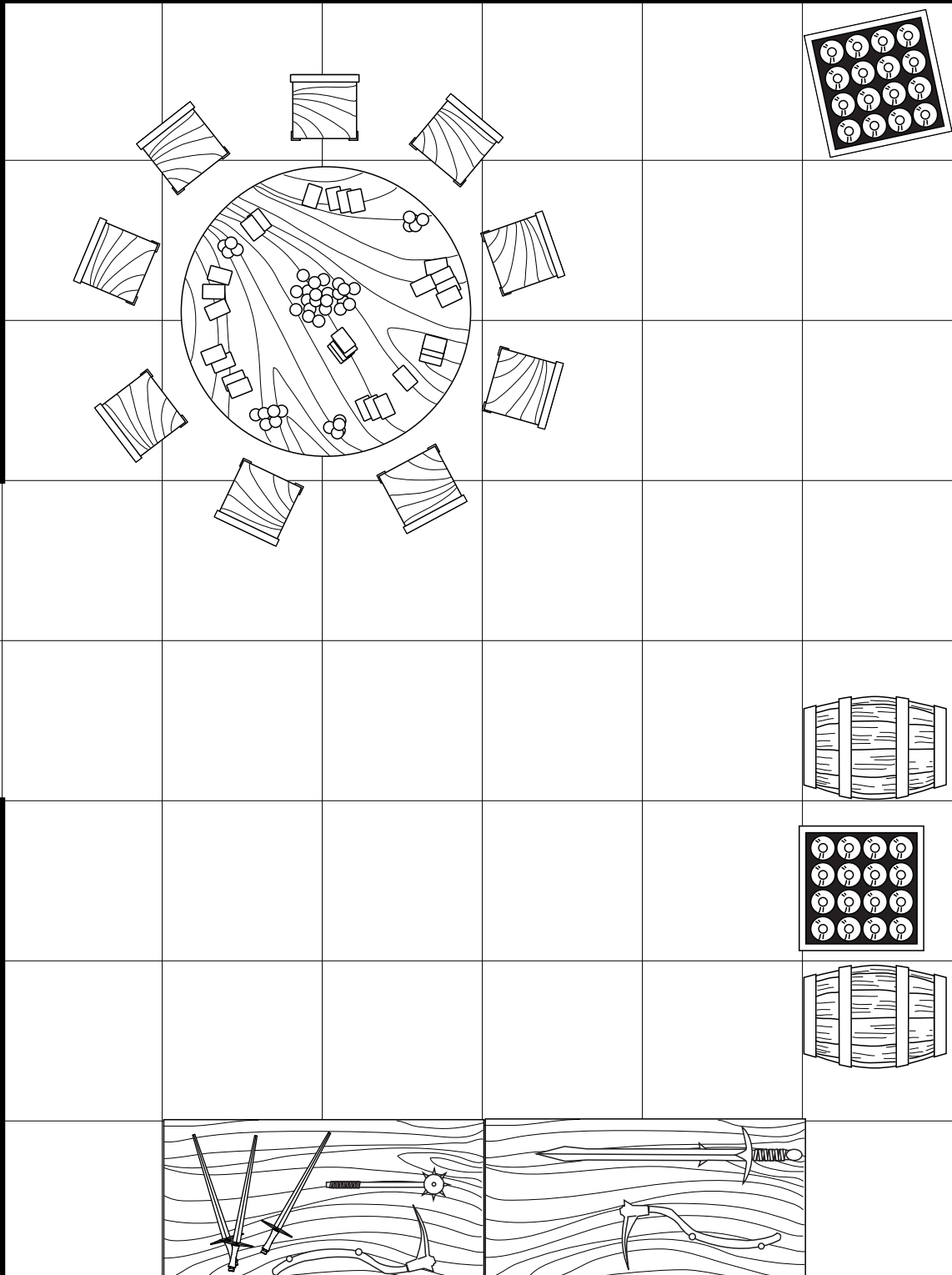

TERROR#57

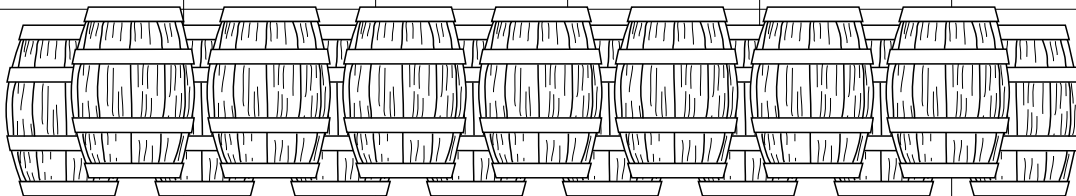
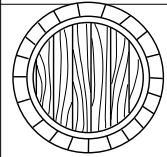
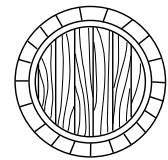
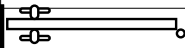
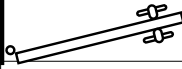

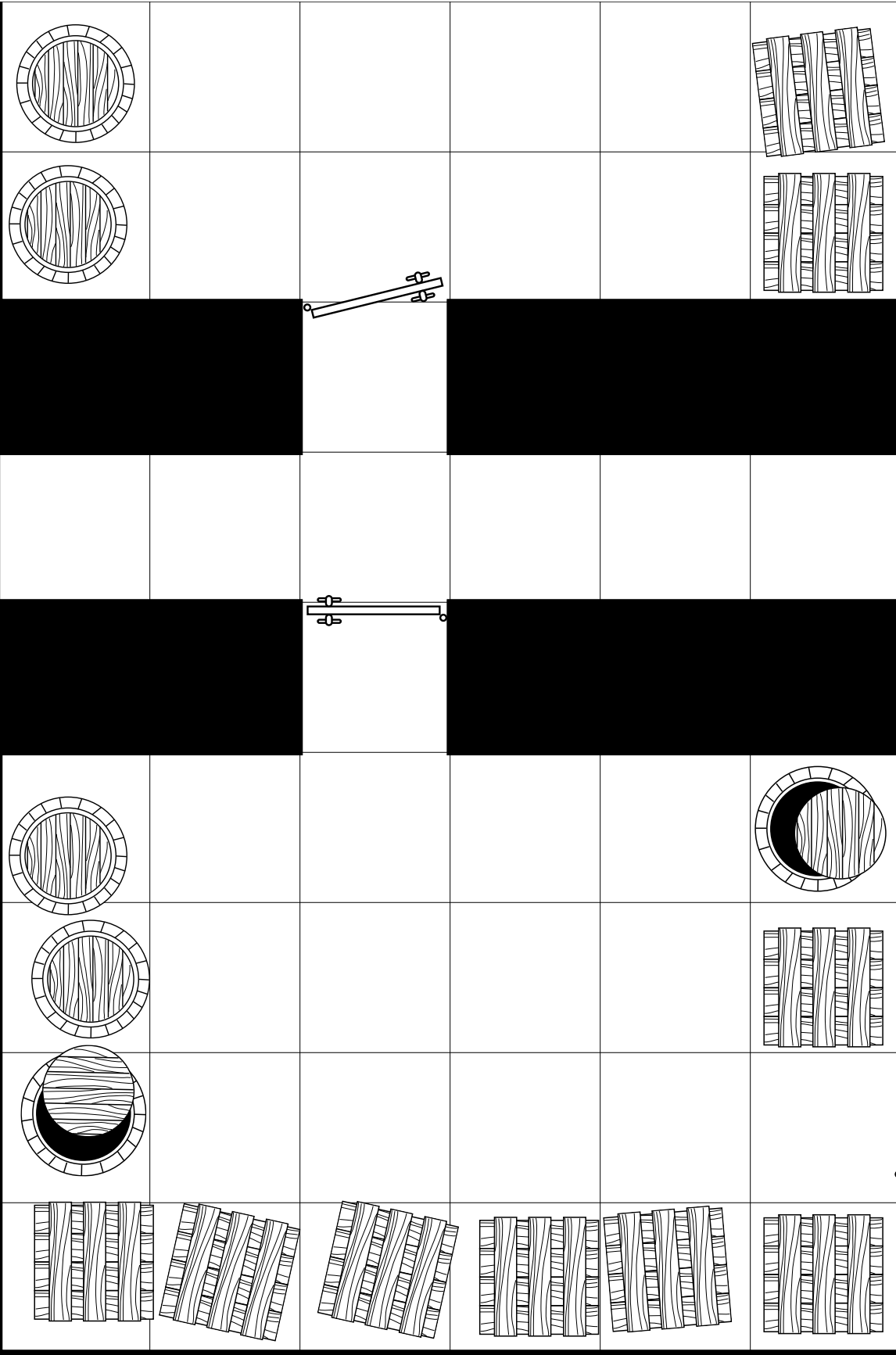

TERROR#59

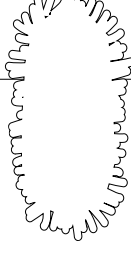
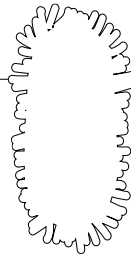
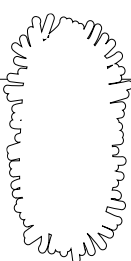
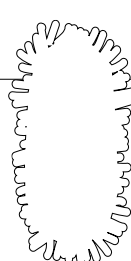
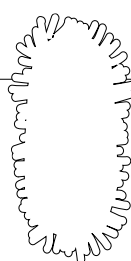
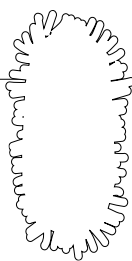
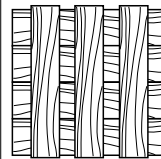
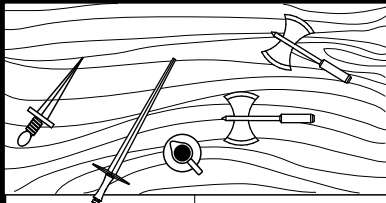
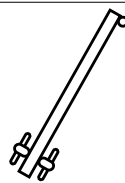
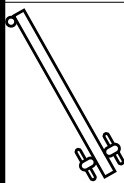

TERROR#60

© 2006 Canusa, permission granted to print for personal use only

