

CLASSIFIED

HOMES

FARMHOUSE



FEATURED HOME

About this listing

A foamcore wargame terrain project suitable for 28-32 mm miniatures. Listed by

Stoelzel's Structures

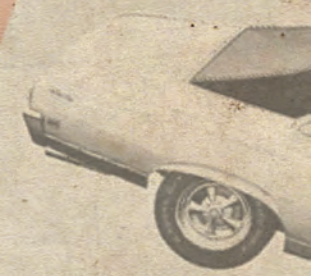

FEATURE

About this listing

Asking price: \$5.00

Lorem ipsum dolor ante in

Classifieds

An old rustic farmhouse, designed for practical and efficient living. This historic home was fully renovated by the previous owners. This stick built house is a two floor home, complete with three bedrooms, one bathroom, kitchen/dining, and living room. This home packs in 110 inches of living space. Located five miles from... ..anything.

Width: 7.5 inches

Depth: 7.33 Inches

Height: 6.5 inches

Fixer-upper potential: 1-2 hours.



Build instructions: The Abandoned Farmhouse

Legal

All images and text contained within this project are copyright of Carl R. Stoelzel. Permission is granted to print copies of this to build only your own projects. Do not distribute digital copies in whole or in part without the express written permission of the copyright holder.

Forward

Given a baseline level of difficulty as simple folded cardstock square buildings with at most 6 folds and three glue tabs, than this model is of intermediate difficulty. It was designed to be made primarily of foam core, and often requires the modeler to line up pieces of artwork on both sides. This model will take between one and two hours to build.

Materials

- 1 large sheet of 5 mm thick foamcore
- Thin Cardstock, a used cereal box should be about enough
- A straight edge (metal rule is preferable)
- A sharp blade (for example an X-acto knife)
- Gluegun and glue sticks
- Cyanoacrylate (Crazy Glue)
- Full sheet label paper (Optional)
- Spray mount and fancy printing paper(Optional)
- A Rabbet cutter (optional)
- A small (~5mm) chiseling blade (optional)
- Black magic marker (optional)

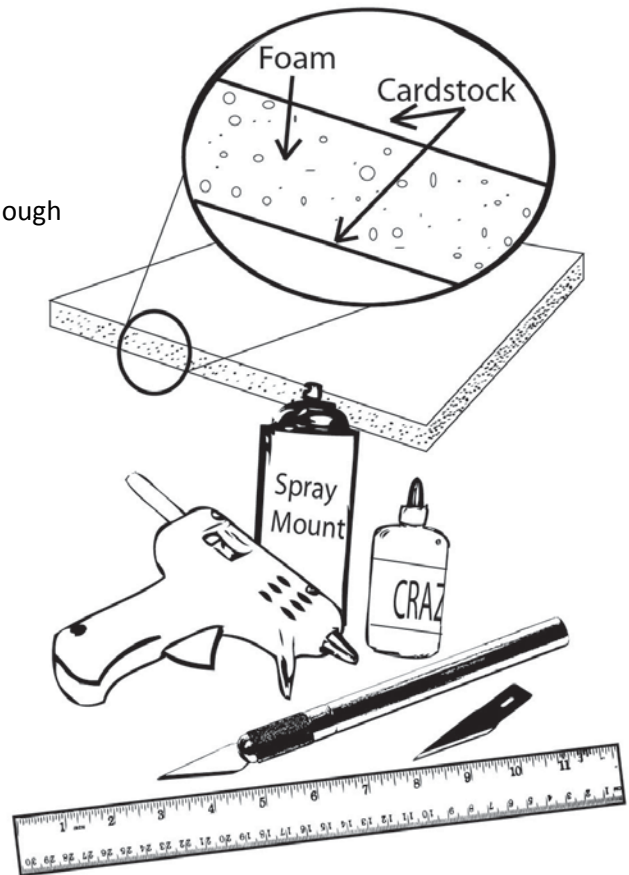

Techniques

Mounting

Most pieces of this building have images for the front and back of the foam core support structure. As such, great care should be taken when aligning the pieces. There are two options available to mount the artwork onto the foamcore.

The first option is to print out all the art files onto full sheet label paper. This provides a very simple assembly: peel the back and stick. However, the quality of full sheet labels can be hit or miss, and, in the worst cases, can lead to peeling terrain.

The second option is to use an aerosol glue like spray mount or photo mount. Generally these come in two types, a permanent fix and a temporary fix which lets you take the pictures back off later. The temporary fix glue is good if you don't trust your ability to align the two sides, but like the label paper CAN lead to peeling terrain down the road. It should be noted that both of these sprays is that they can be messy and smelly. Please follow all directions on product chosen.



Rabbeting

Sections which need rabbeting are indicated in the pictures by large blue boxes.

Making a rabbet on one of the pieces of foam, allows us to create a stronger joint when joining ends of two foamcore pieces. This is accomplished by creating a slot or groove to receive the edge of the other foam core piece. This ensures that the seam of the joint is surrounded on three sides. Rabbeting your corners and joints also helps hide exposed edges of foam.

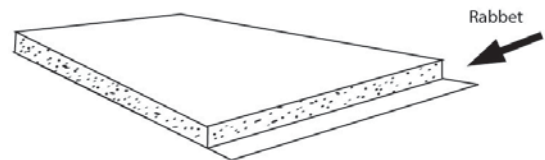

A rabbet joint is made by cutting only partially through a piece of foam core while leaving the opposite side of card stock backing still intact. One must be careful not to cut all the way through, as this could ruin the images on the other side, and also make the piece un-useable.

T intersections where an end piece of foamcore butts up against another perpendicular piece of foamcore can be made stronger and smoother using an interior rabbet joint. These are a bit trickier, but not that difficult to do. An example can be seen here.

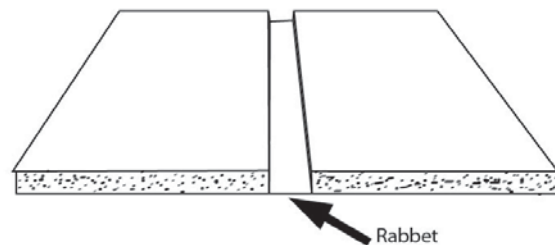

There are a lot of tools available online called foamcore rabbet cutters than can make doing rabbets somewhat easier for the modeler. These rabbet cutters fix the angle and depth of the cutting blade, thus preventing cut through. If you don't have a rabbet you can do these same cuts with a simple blade and a little care.

Build Instructions

1. First locate and cut out the four sides of the house (**A,B,C,D,E,F, G, and H**) and the first floor (**I**).

The two peaked ends of the house have two separate art pieces each (**A and B** together and **E and F** together). For the outer walls of each house end, fold the two black tabs that follow the roof line up to face the picture side (away from the foamcore). Place one of these (**A**) on a piece of foamcore with the straight edge to one side. Test fit for size. Mount the picture on the foamcore, be careful NOT to attach the two black tabs. Cut out around the edge of the image using a straight edge as additional guide. When cutting the top of this, you should be cutting away all the foam that was under the black tabs before they were folded (i.e. along the fold line). Once this is cut way, wrap the black tabs around the edge of the foam and mount it to the opposite side.

Locate the corresponding piece (in this case **C**). Using the same straight edge that was used as reference before, place the art on the opposite side and test fit. Once you are happy about its placement, mount.

Repeat this process for the other high peak (**E and F**) and the two long sides of the house.

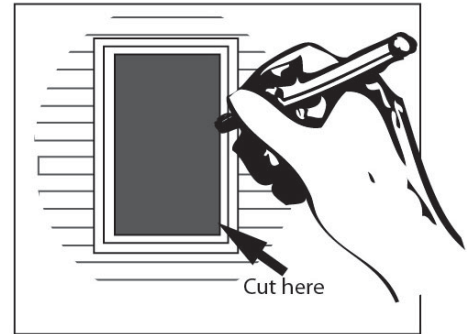
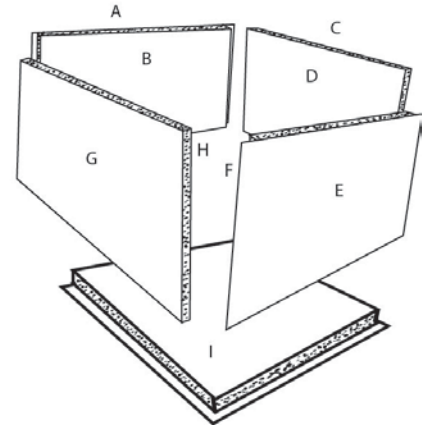

2. Cut along the out borders of the artwork using the inside of the edge as a guide. There are two blue borders on each side of the inside. Rabbet these leaving the cardstock on the outside of the piece somewhat longer than on the inside.

The small blue box in the middle of the first floor indicates an internal rabbet. Cut along the side and top of the blue box without cutting all the way through. Using a chiseling blade, or using a regular blade very carefully cut the foam block from the wall. Work from the exposed bottom to the top. Gently pull away the foam as you work up.

Repeat this step for the other wall section (**F**).

IF you wish to remove the windows and doors, now is the time to do it. Be sure to leave the window/door frames intact when cutting along the item.

....Oops. One potential error is not aligning the doors and windows properly on the two sides. This is evident when you cut through the foamcore. To correct this, or rather, to hide this, additional door frames and window frames can be found at the end of this document. They are purposely oversized to accommodate a couple millimeters of error. Window and door framing should be done at this time.

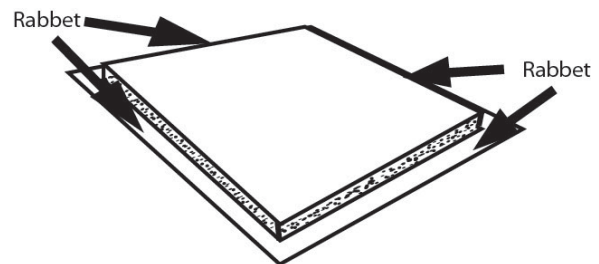

3. Locate the flooring for the first floor (I) and cut away scrap paper. Test fit on a piece of foamcore and mount. Rabbet the boarder along the edge of flooring leaving the underside card intact.

4. Test fit the floor house walls around the flooring (I). Once you are confident with the fit, use the glue gun to glue the rabbeted corner to its mate one corner at a time. After each corner is attached, recheck the fit of the walls to the floor.

Alternatively, you could use white glue to attach the walls. Use rubber bands to hold the walls together around the floor until the glue dries.

Do NOT attach the house to the floor just yet.

....Oops. A potential mistake is to make the rabbets too shallow on the wall seams. This would allow for some of the inner foam to show through on the outer corners of the building. Additional wall trim is available at the end of this document to reapply and hide such seams. These are purposefully oversized and can be trimmed to accommodate your needs.

5. Locate and cut out the stair walls and the stair riser/runners. Mount the stair walls on a piece of foamcore. Cut along the out borders of the stair walls. Turn the piece over. Mark and rabbet the middle section. Fold the walls at the bends (90 degrees) so that the artwork faces out.

Mount the stair risers/runners onto a piece of card stock. Cut out piece. Bend along each black line in an alternating/accordion fashion.

Attach/Mount the stair risers/runners section to the stair walls using a glue gun, attaching from the underside.

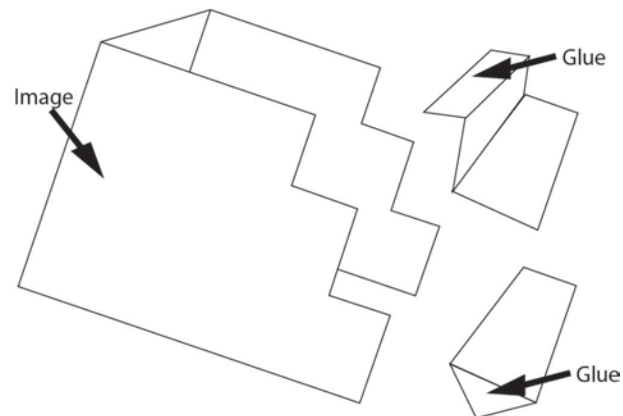

6. Locate and cut out all the interior walls for the first and second floor. All these pieces use a wrap over technique. Fold along the long sides of the black box which separates the front from back of the all piece. As you did in **step #2**, ensure the piece lines up front and back. Mount and trim.

IF you wish to remove the doors, now is the time to do it. Be sure to leave the door frames intact when cutting along the item.

7. Locate the flooring for the second floor (J). Mount onto foamcore. Trim piece. Test fit the piece to make sure it fits slightly loosely inside the house. Piece will not be permanently attached and should be loose enough to remove when necessary.

8. Assemble the first floor interiors. The first floor interiors consist of the wall and the stairs. The wall should fit snugly into the interior rabbets of the outer wall section you made in **step #2**. The section of wall labeled "glue stairs here" should face the larger section of the room (i.e. away from the kitchen). Test fit the piece in the walls. Test fit the whole piece (outer and inner walls) against the floor to make sure everything lies flat. Remove. Glue in place and re-test fit.

Test fit the stairs section. Use the glue gun to glue the back of your stair section to the interior cross wall where indicated on the art work. Test fit the house and stairs against the first floor interiors.

Test fit the second floor flooring again to make sure it fits around the newly installed stairs.

9. Assemble the second floor interiors. Grab the second floor flooring (J) and the second floor wall pieces that you have already mounted. Rabbit out the blue boxed areas of the two hallway pieces. Fold along the corner and test that these fold easily at 90 degrees.

Mount the two all pieces to the second floor flooring with a glue gun using the thick black lines on the floor as a guide. Test fit the piece in the house again and make sure the floor slips over the stairs with ease, trim as needed.

10. Locate and cutout all the roof support beams. Fold along the black lines (90 degrees) so that the artwork faces out. Mount onto and edge of foam core. Cut along the black border to remove.

Locate the roof piece. Mount on cardstock. Cut along the black border to remove. Fold the roof section along the black line and test fit the bend on your existing house structure. Fold along the middle black line roughly ninety degrees so that the images are on the outside of the bend.

Glue the roof support pieces under the roof section using a glue gun.

IF, you glue these support beams near the ends of the roof (about ~4.5 mm from edge) then they should also provide a slight resistance which fitting the roof on the house. That way it won't accidently slide off all the time. However, if you place them too close to the edge, there will be too much resistance to put the roof on properly. Attach one beam, check the fit again, and then attach the other one.

Furniture Build Instructions

Print the sheets of room fixtures on heavy bond paper. Some of the flat pieces such as paintings, window frames, door frames etc you might like to mount onto thick card. Most the furniture will be too difficult to fold on thick card.

Cut out all your furniture and decorations. Draw around the edges of your cuts with black marker.

Fold along thick black lines. Use tabs to glue opposing sides of a piece or to glue a piece to the house.

A note on folds: There are two main types of folds you will need to make: Convex and Concave. Convex folds refer to any fold (90 or 180 degrees) where the images remain on the outside of the fold surface. Or in other words, the two sides of the fold are pushed away from each other. Concave folds are done in the opposite direction, with the images being brought toward each other.

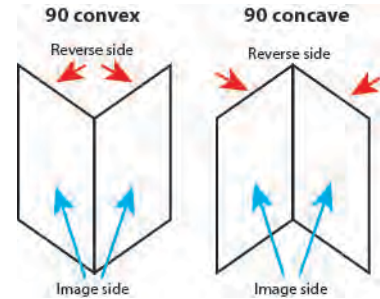

Chairs and Couches

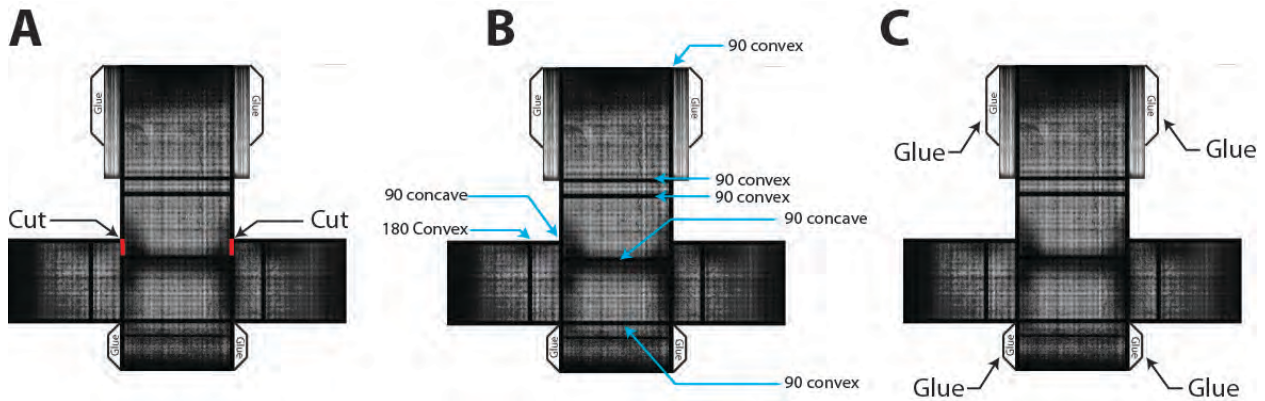

Tables and dressers

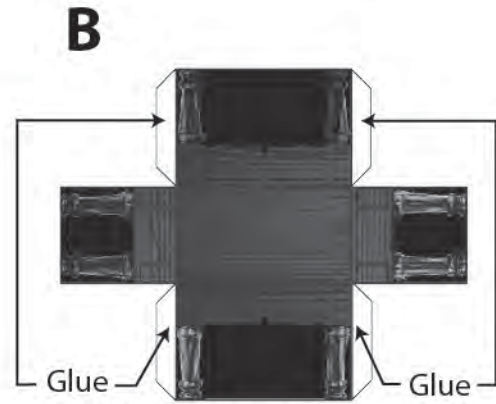
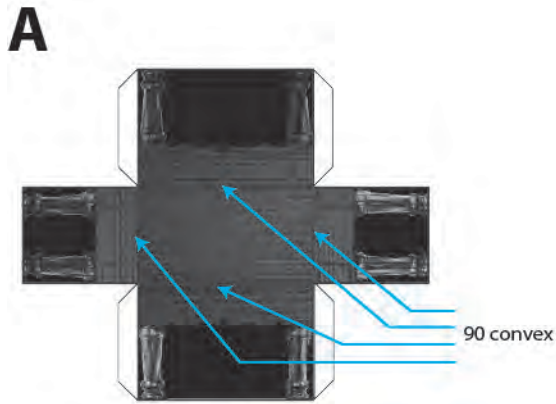

Bed

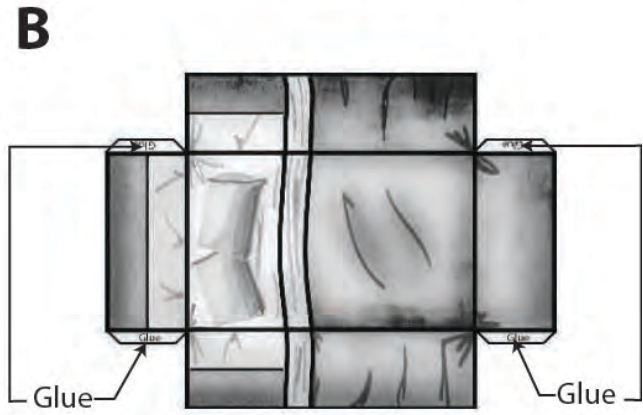
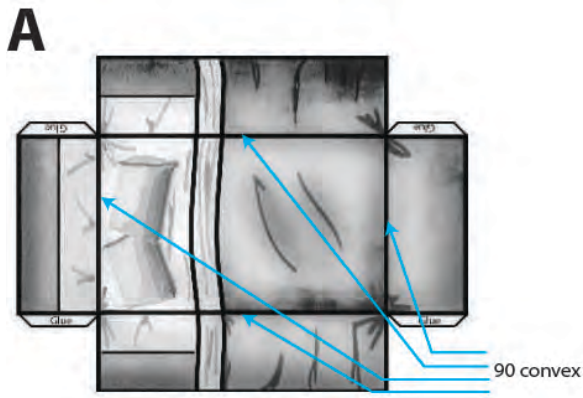

Sink

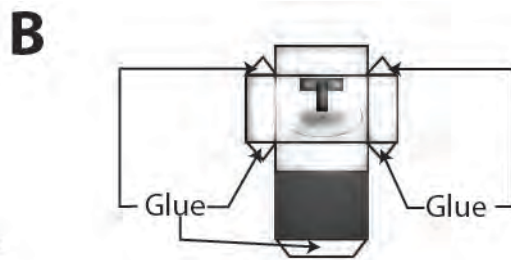
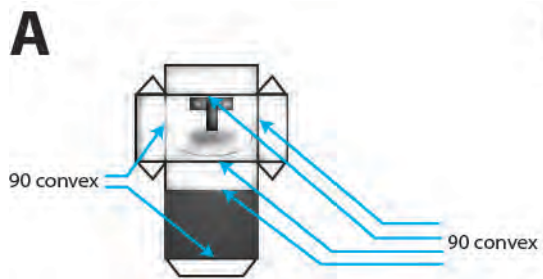

Attach to wall with Cyanoacrylate.

Toilet

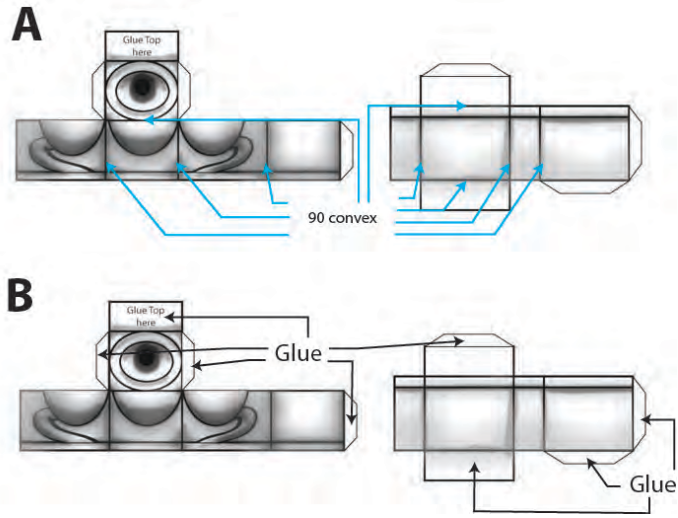

Bathtub

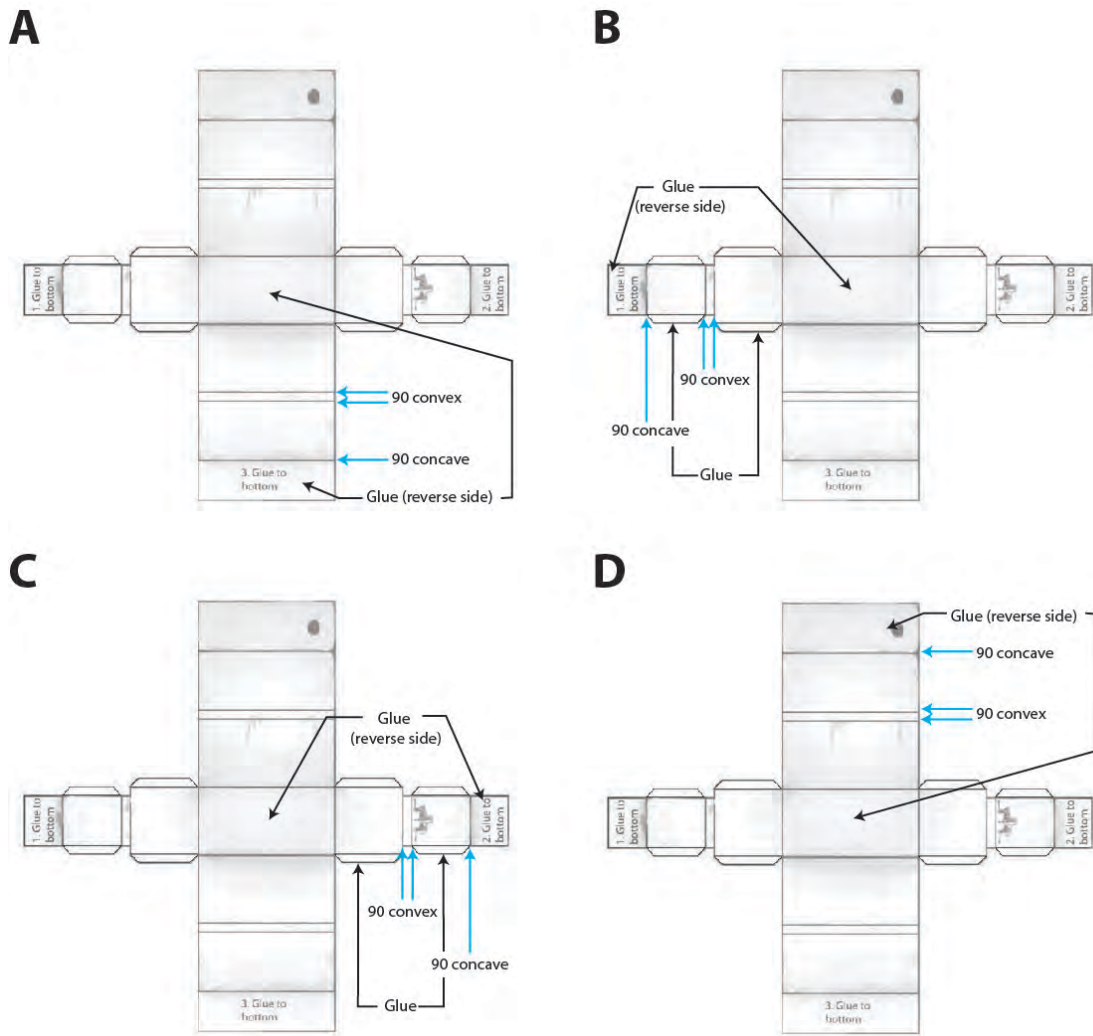

A



NOTICE

All images contained within this product are copyright of Carl R. Stoelzel. Print permissions granted to the purchaser only. Please do not freely redistribute any of these images.



B



NOTICE

All images contained within this product are copyright of Carl R. Stoezel.
Print permissions granted to the purchaser only. Please do not freely
redistribute any of these images.



C



NOTICE

All images contained within this product are copyright of Carl R. Stoelzel.
Print permissions granted to the purchaser only. Please do not freely
redistribute any of these images.



D

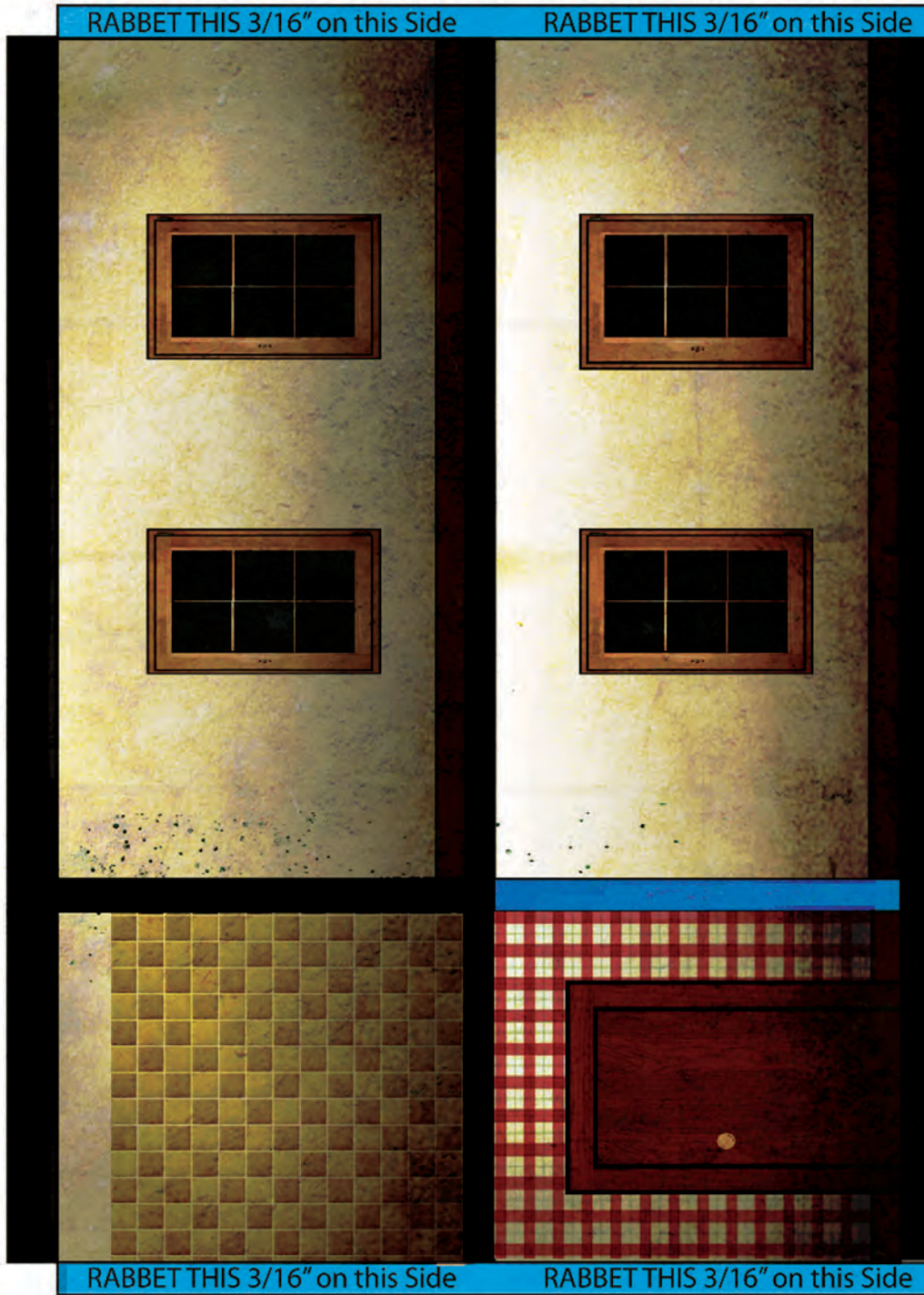

NOTICE

All images contained within this product are copyright of Carl R. Stoelzel.
Print permissions granted to the purchaser only. Please do not freely
redistribute any of these images.



E

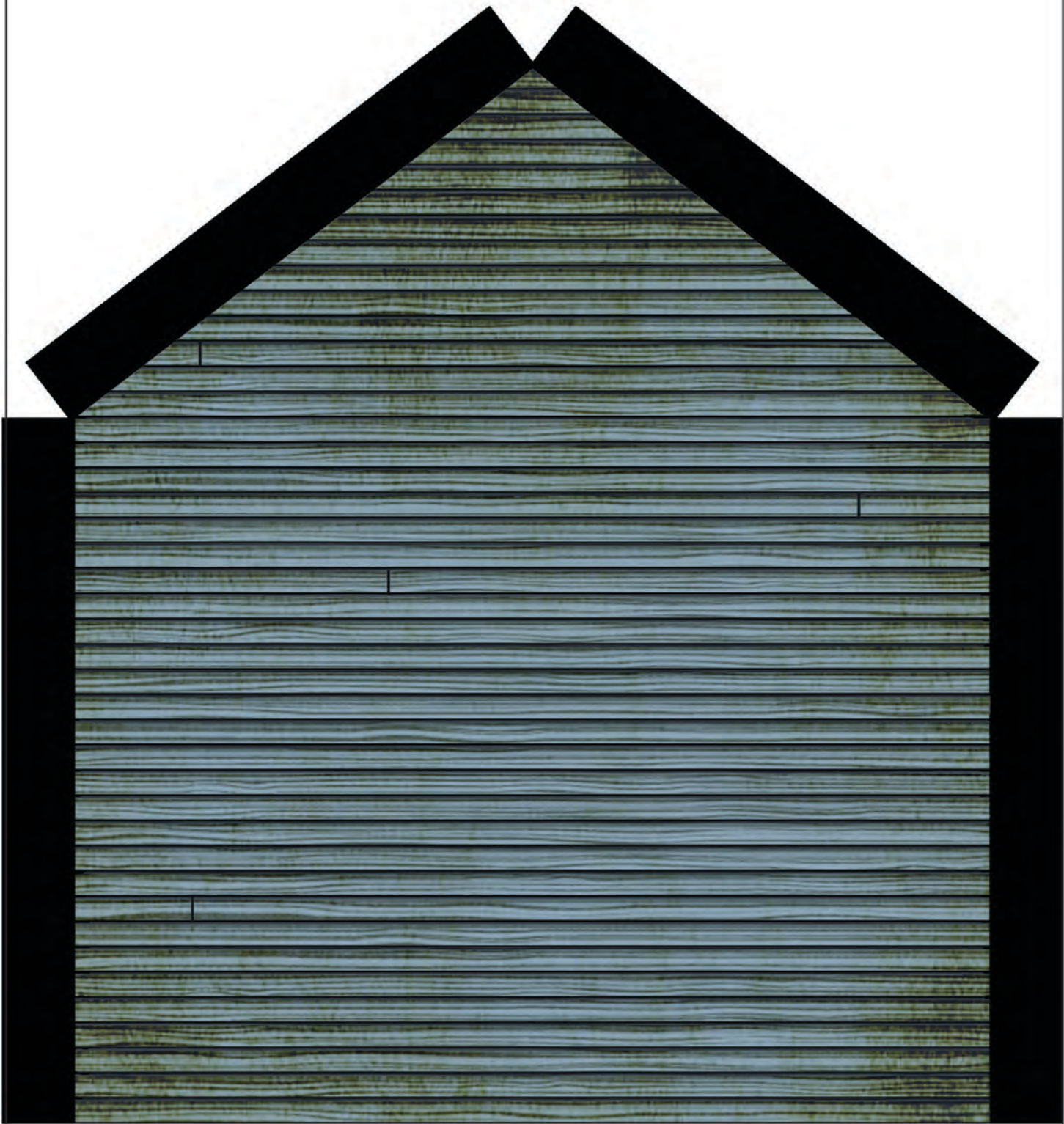

NOTICE

All images contained within this product are copyright of Carl R. Stoezel.
Print permissions granted to the purchaser only. Please do not freely
redistribute any of these images.



F

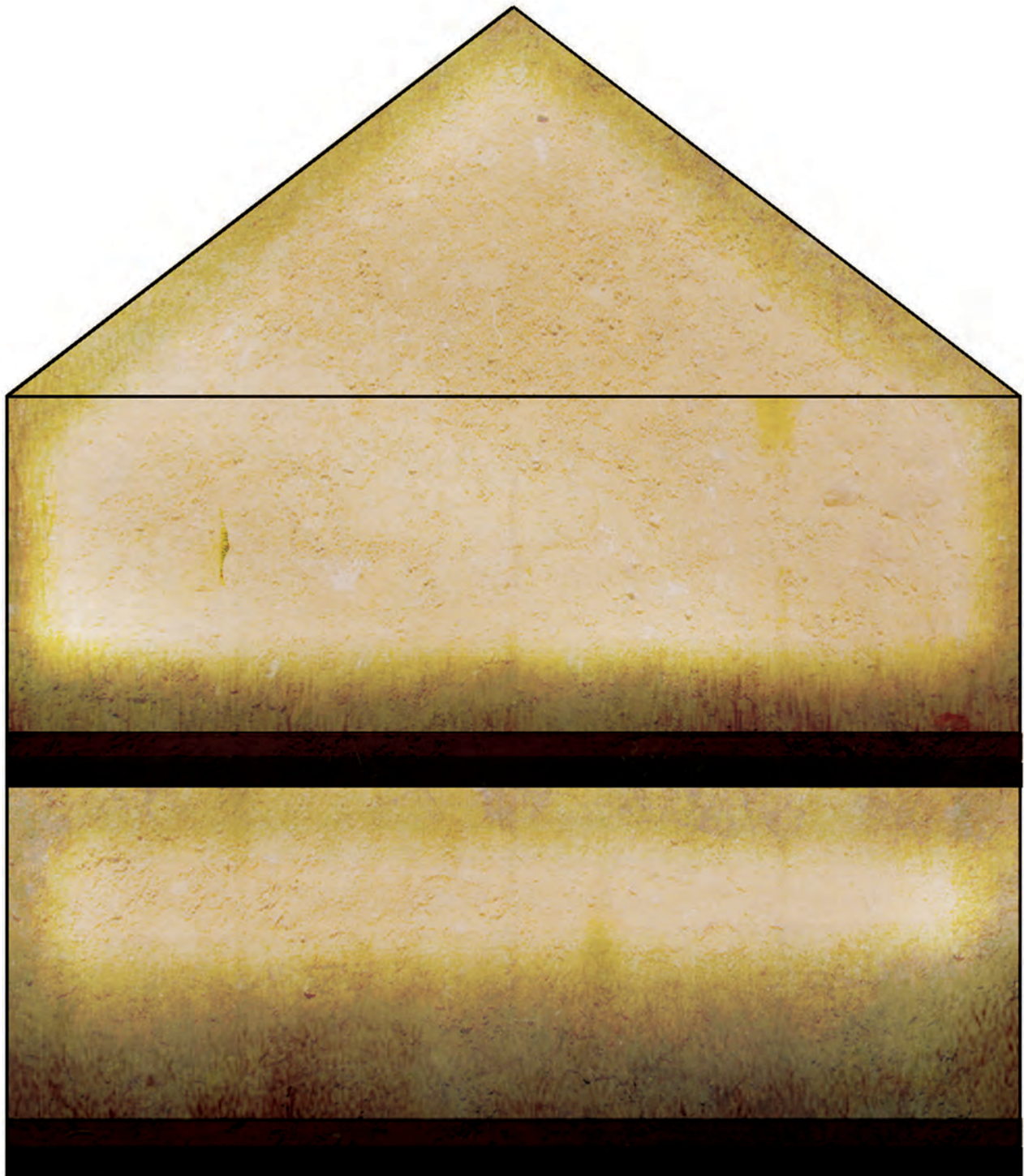

NOTICE

All images contained within this product are copyright of Carl R. Staelzel.
Print permissions granted to the purchaser only. Please do not freely
redistribute any of these images.



G

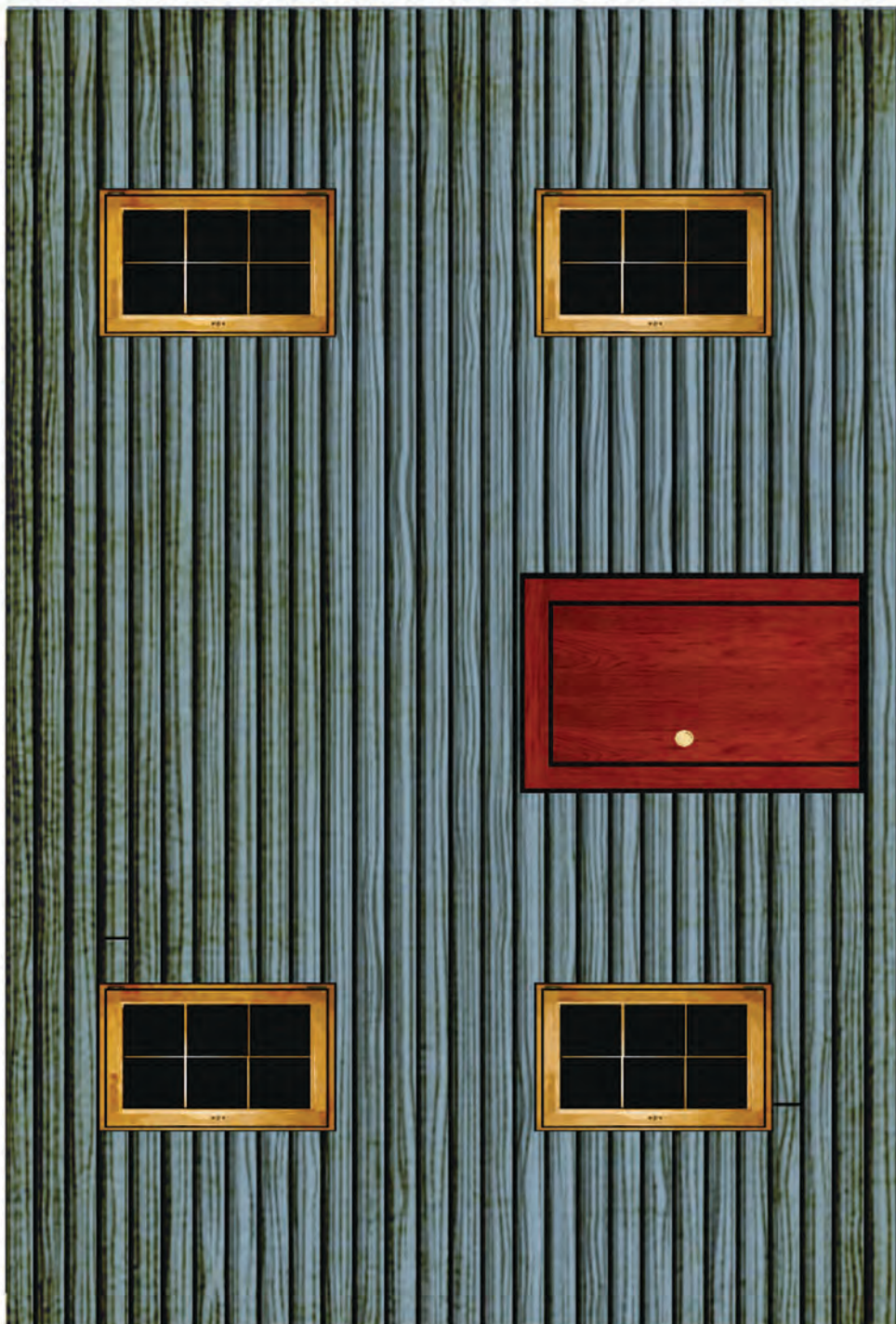

NOTICE

All images contained within this product are copyright of Carl R. Stoelzel.
Print permissions granted to the purchaser only. Please do not freely
redistribute any of these images.



H

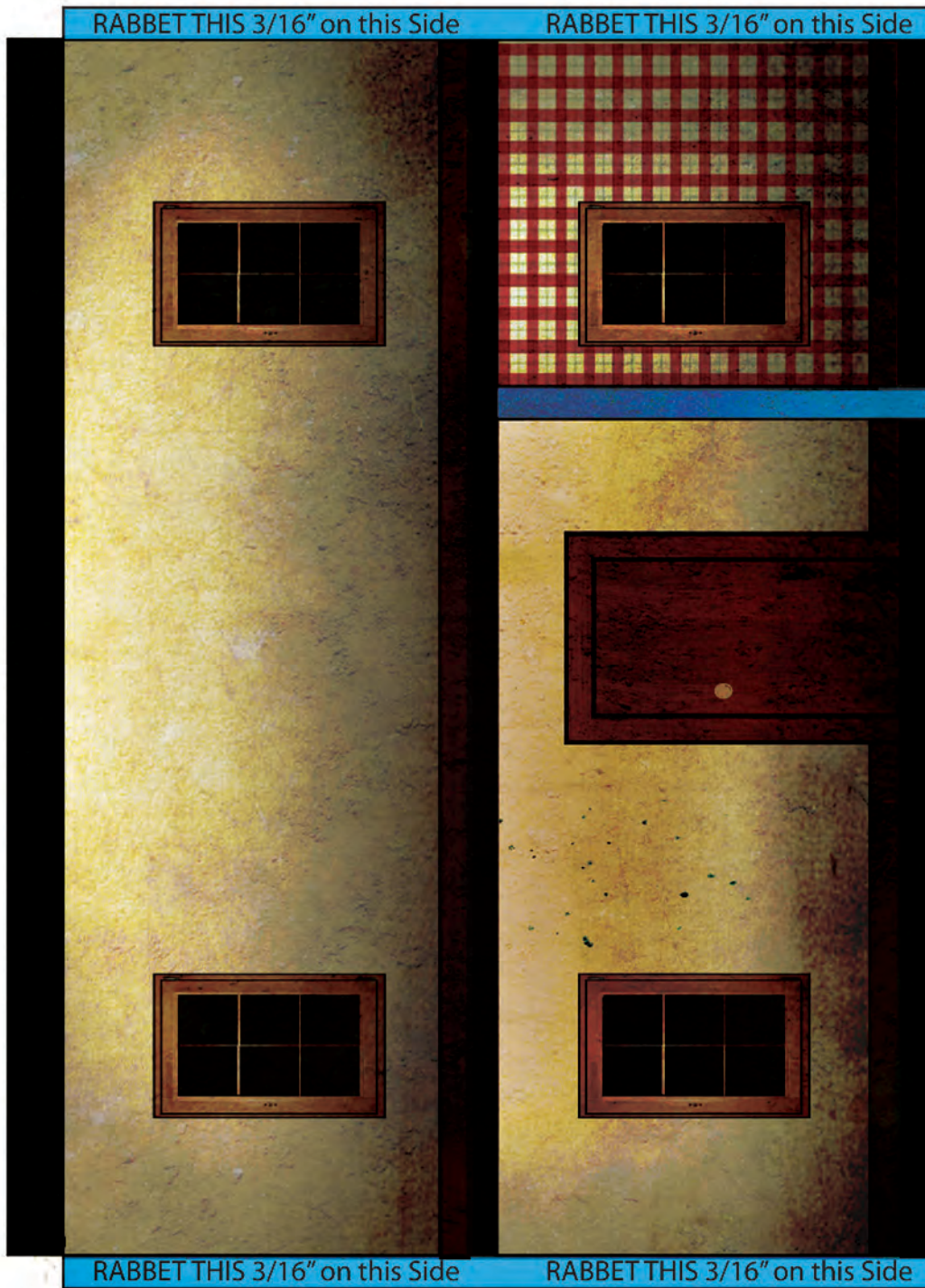

NOTICE

All images contained within this product are copyright of Carl R. Stoelzel.
Print permissions granted to the purchaser only. Please do not freely
redistribute any of these images.





NOTICE

All images contained within this product are copyright of Carl R. Stoelzel.
Print permissions granted to the purchaser only. Please do not freely
redistribute any of these images.



J

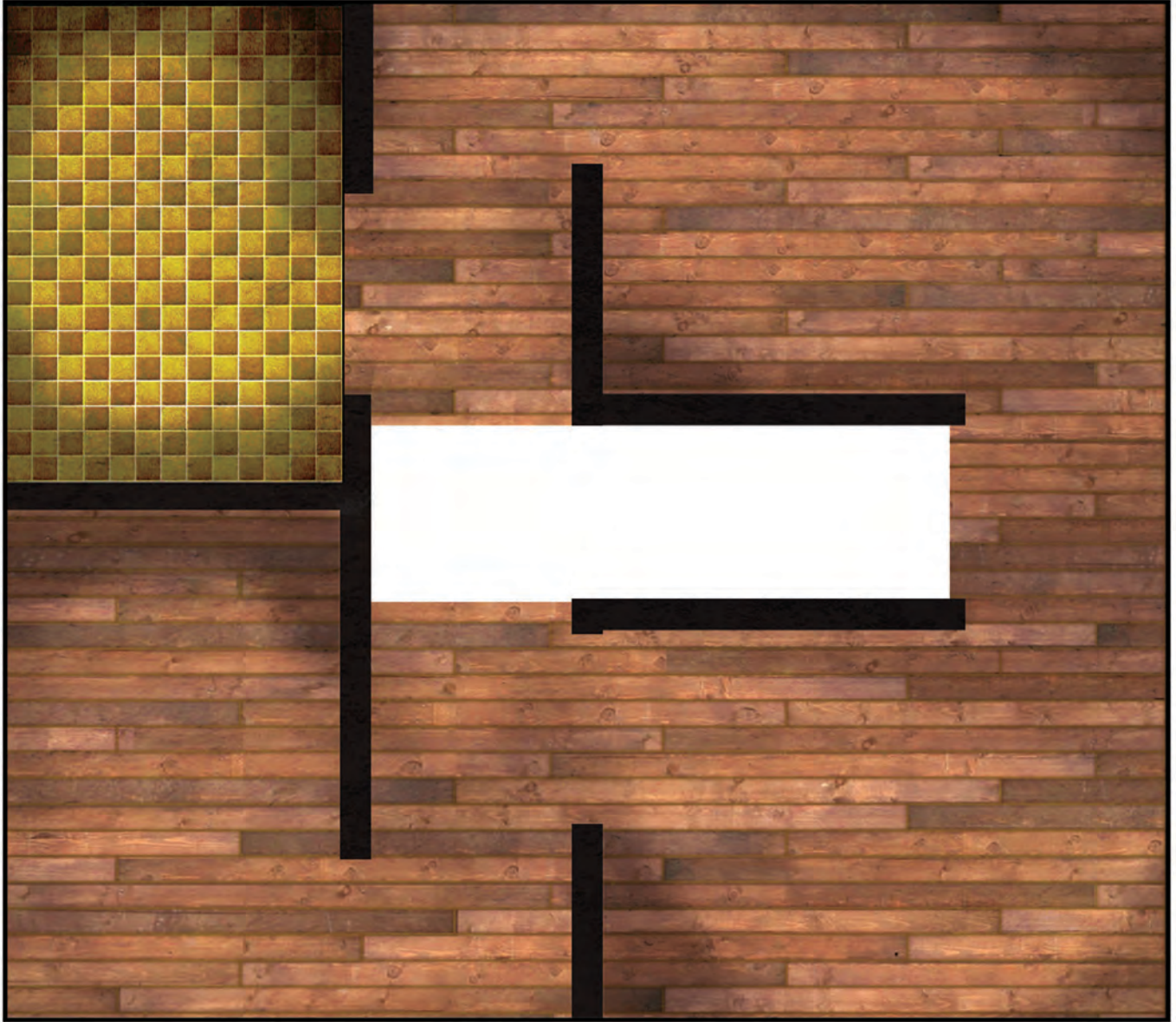

NOTICE

All images contained within this product are copyright of Carl R. Stoelzel. Print permissions granted to the purchaser only. Please do not freely redistribute any of these images.



K

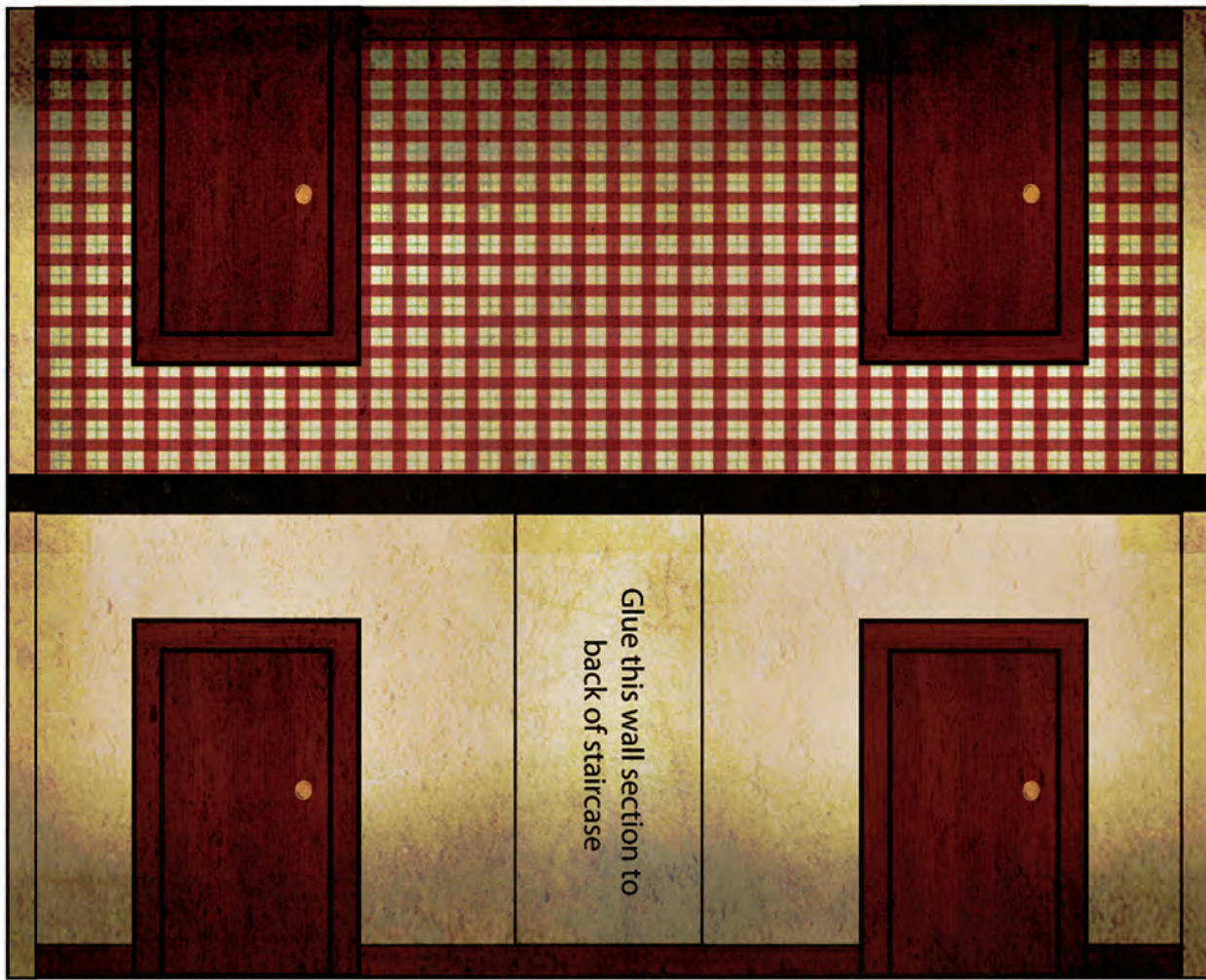

L



M

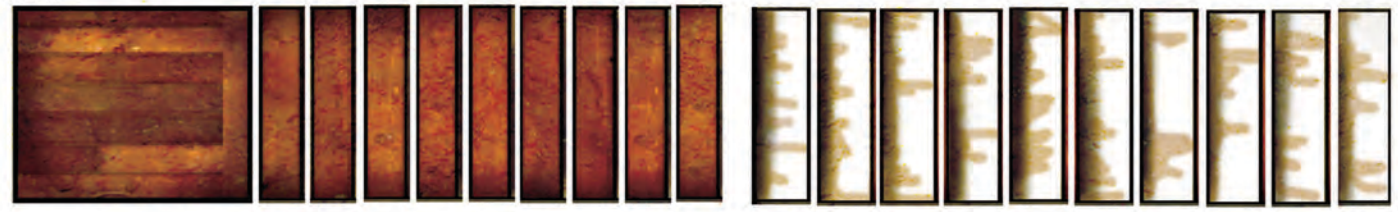

N

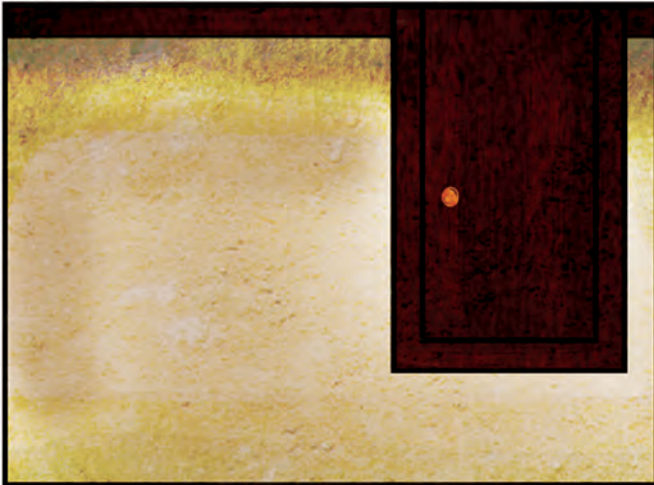

O

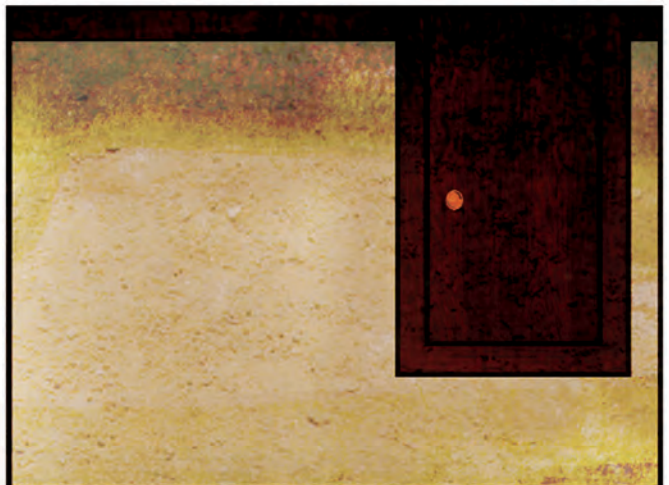

P

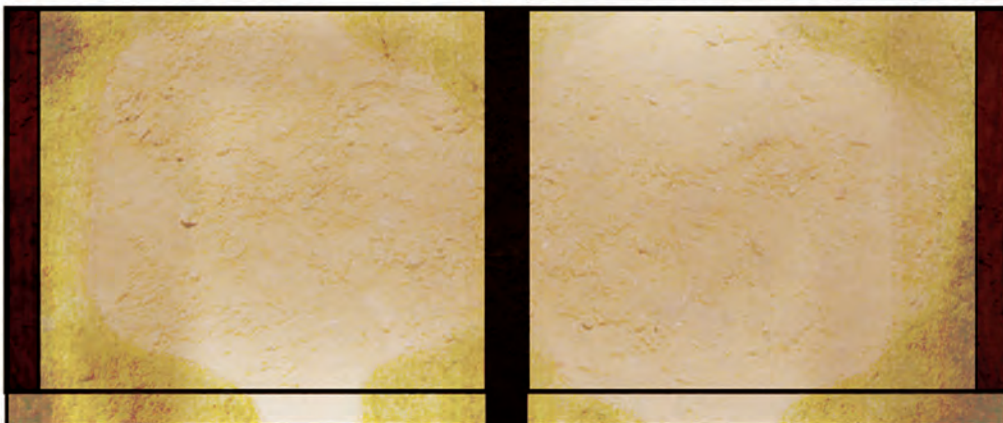

NOTICE

All images contained within this product are copyright of Carl R. Staelzel. Print permissions granted to the purchaser only. Please do not freely redistribute any of these images.



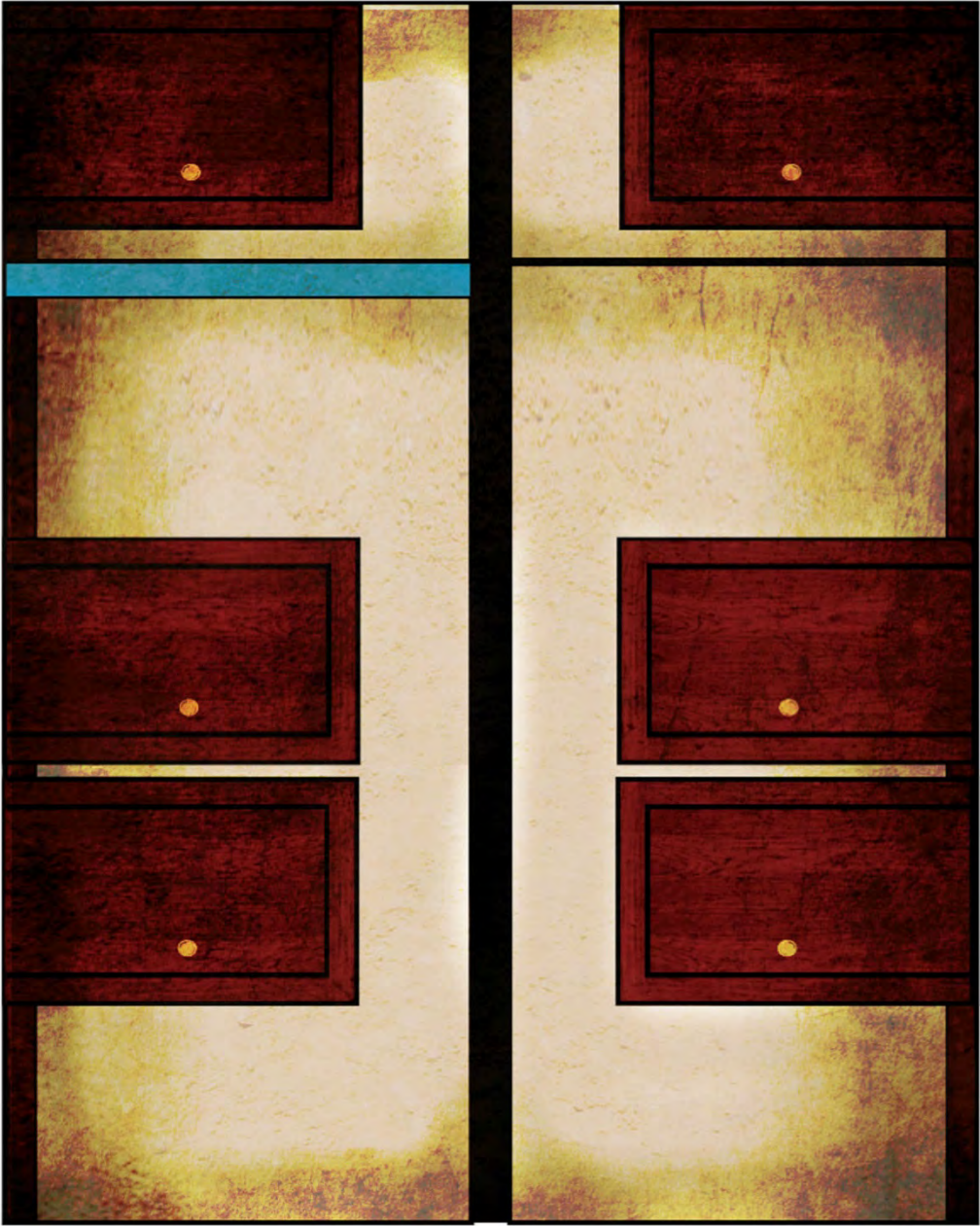

NOTICE

All images contained within this product are copyright of Carl R. Stoelzel. Print permissions granted to the purchaser only. Please do not freely redistribute any of these images.



R

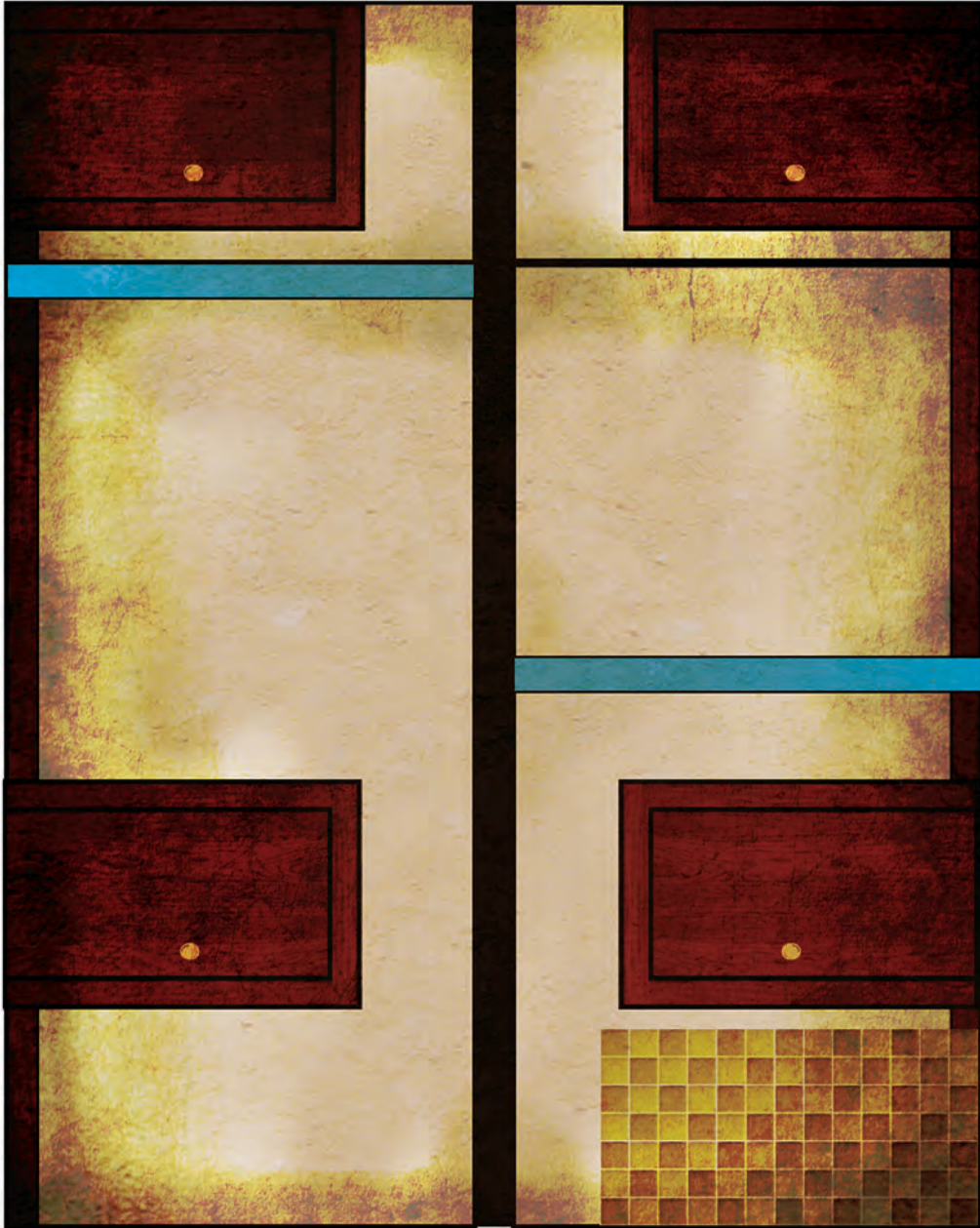

NOTICE

All images contained within this product are copyright of Carl R. Stoelzel.
Print permissions granted to the purchaser only. Please do not freely
redistribute any of these images.



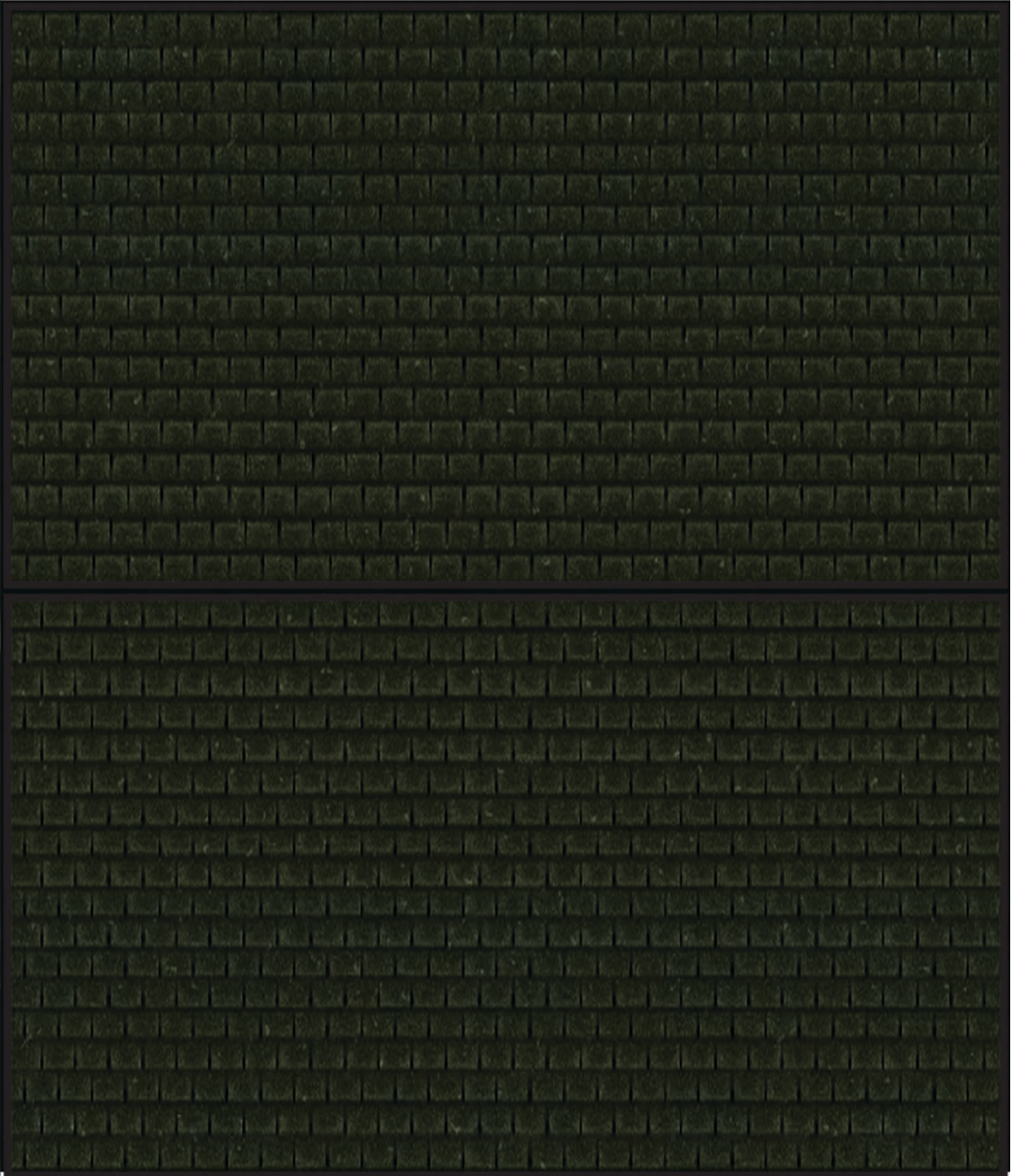

T

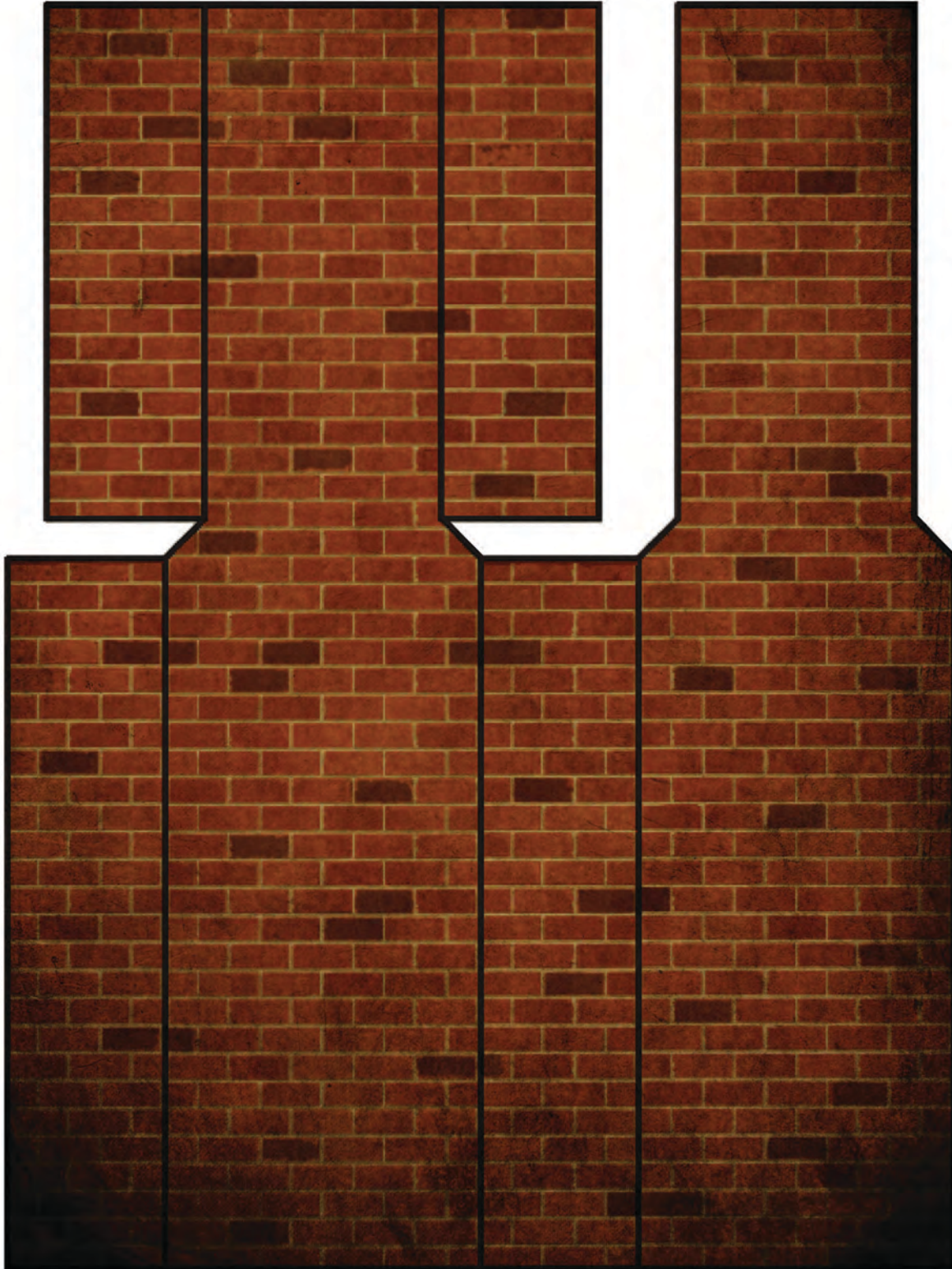

Sides



Top



NOTICE

All images contained within this product are copyright of Carl R. Stoelzel.
Print permissions granted to the purchaser only. Please do not freely
redistribute any of these images.



Roof Supports

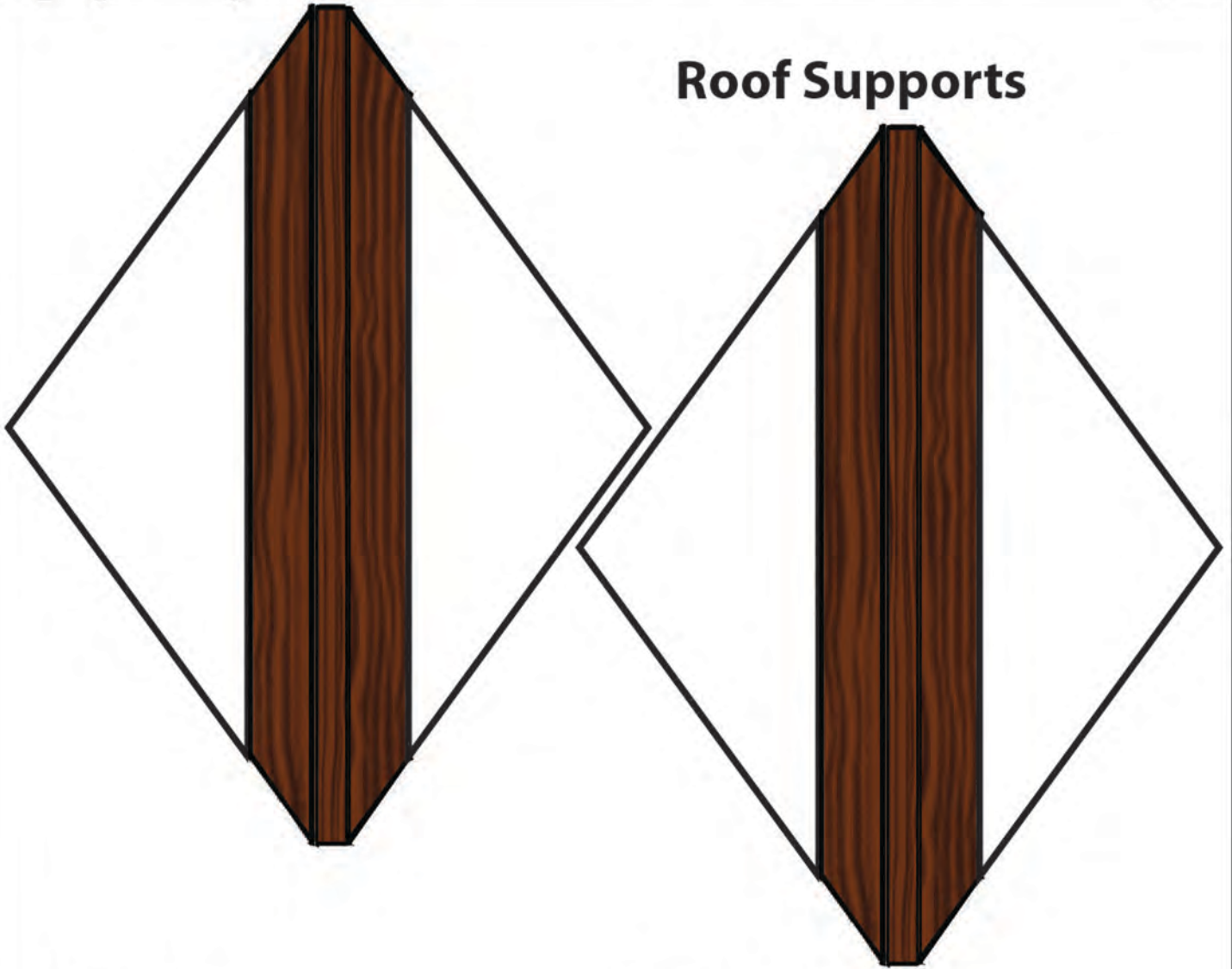

Library

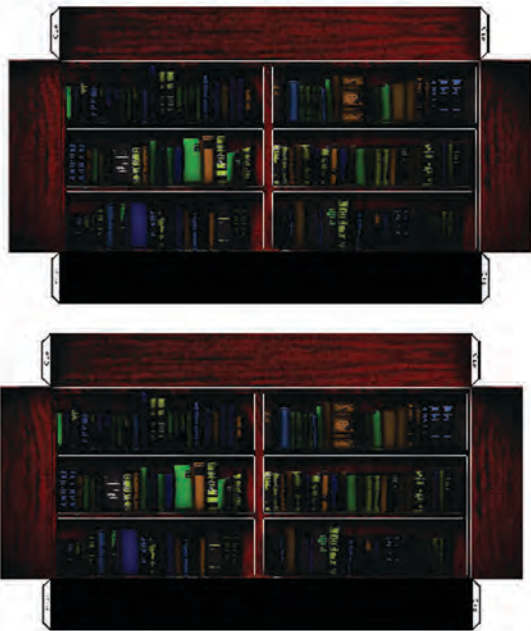

Dining Room

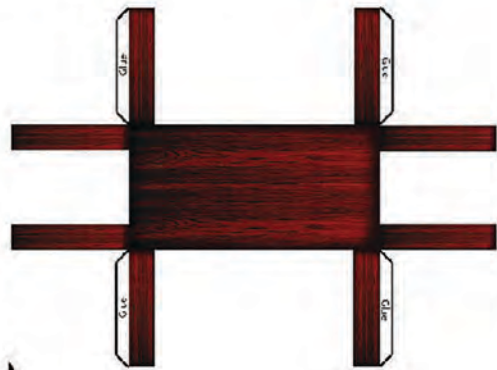

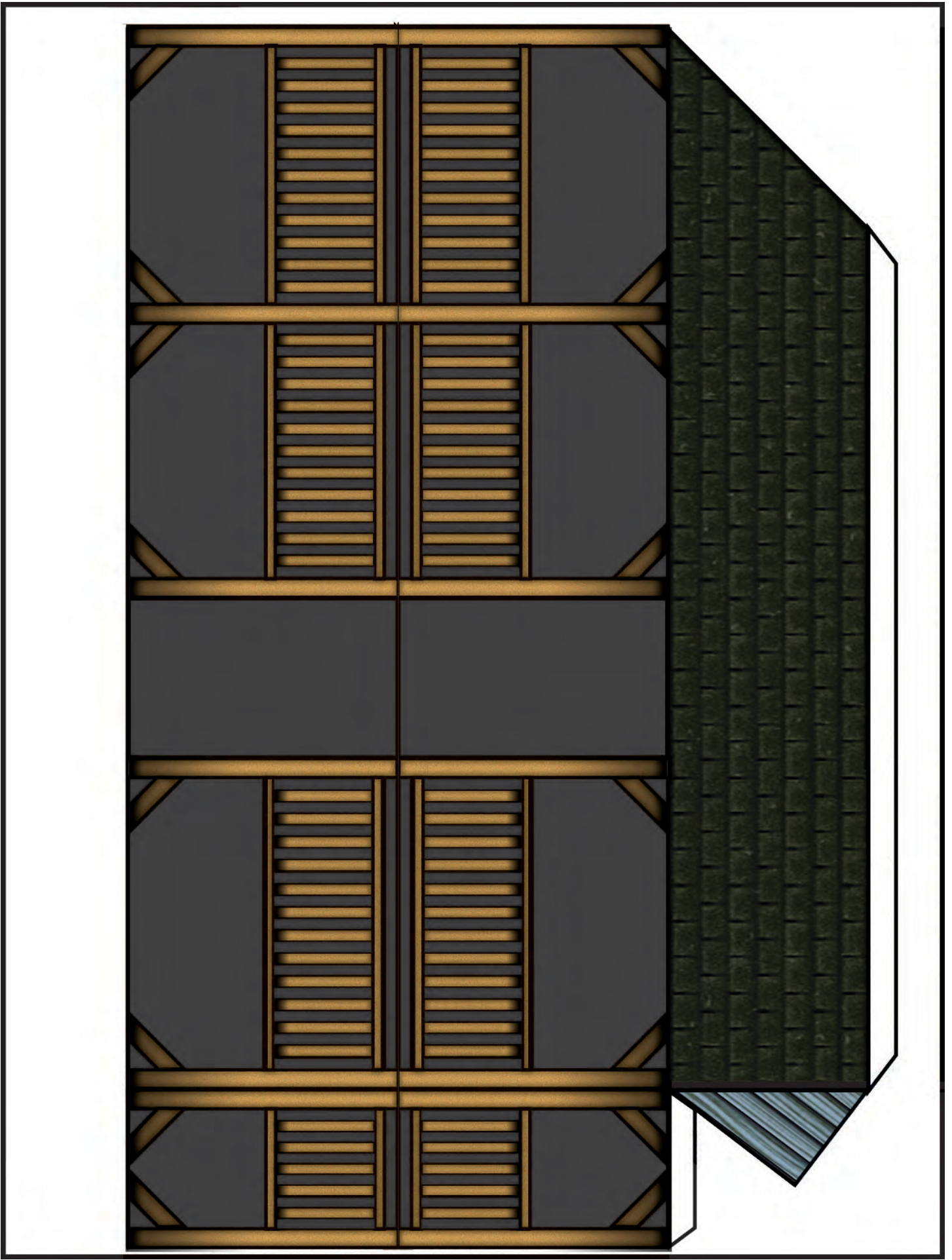

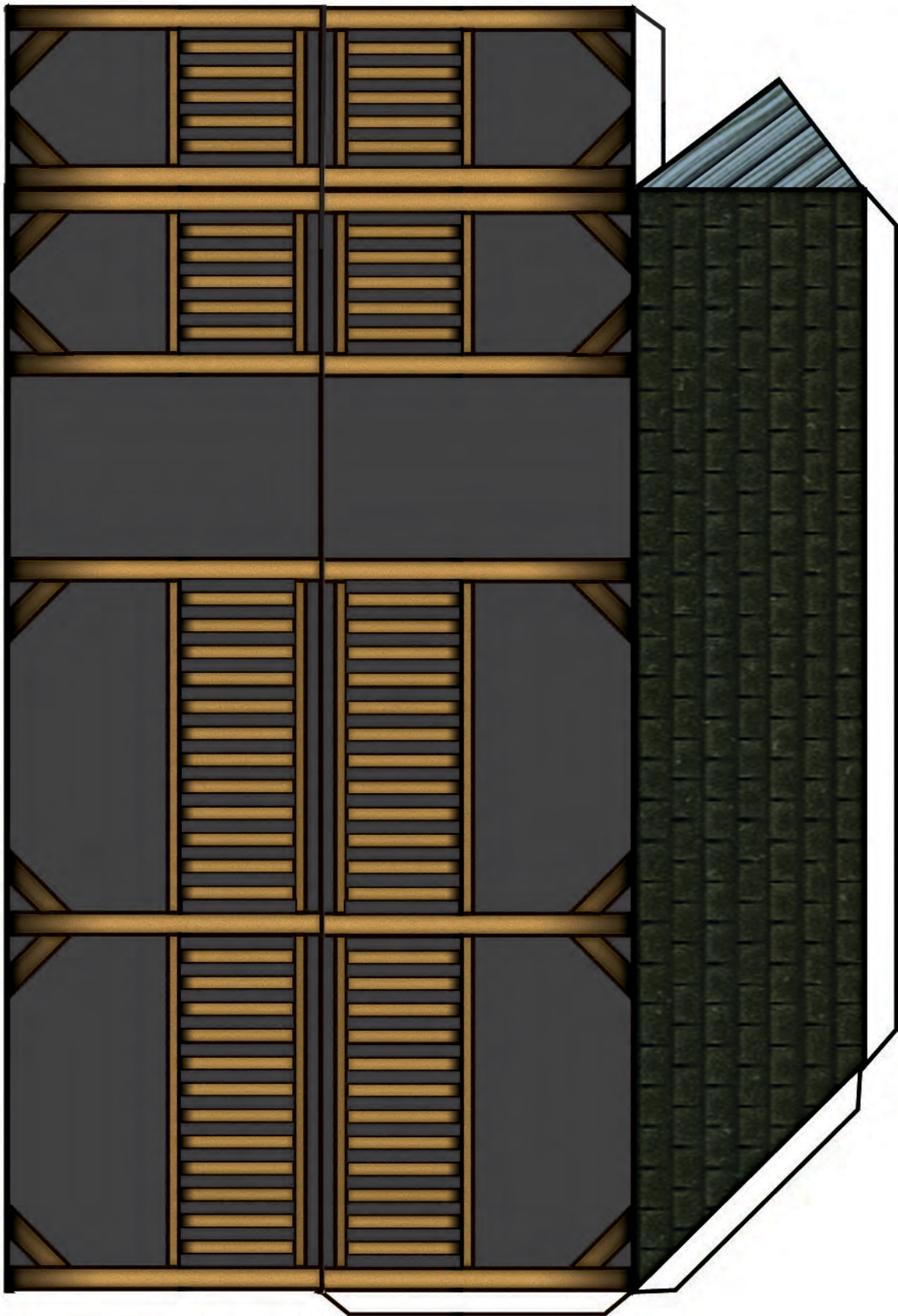

NOTICE

All images contained within this product are copyright of Carl R. Stoelzel. Print permissions granted to the purchaser only. Please do not freely redistribute any of these images.



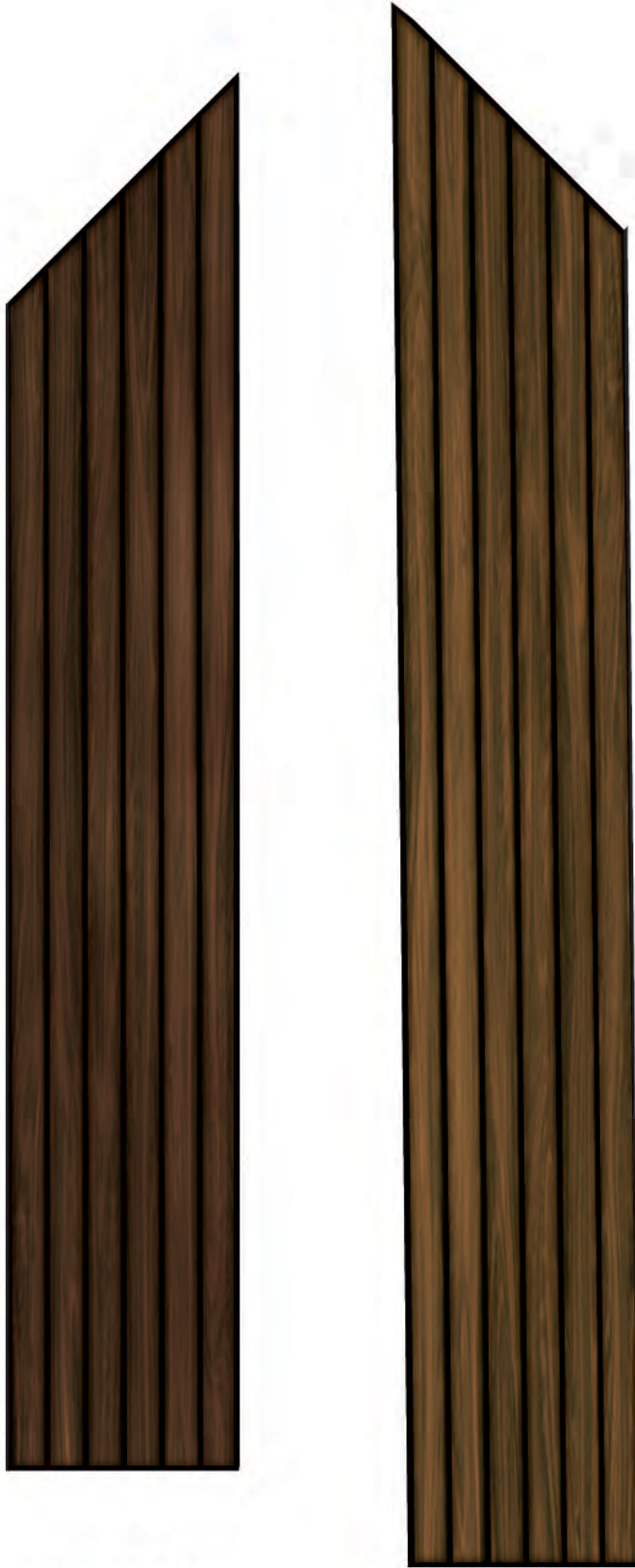

NOTICE

All images contained within this product are copyright of Carl R. Stoelzel.
Print permissions granted to the purchaser only. Please do not freely
redistribute any of these images.



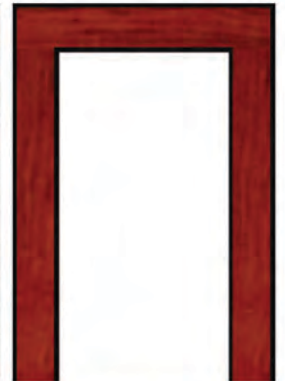
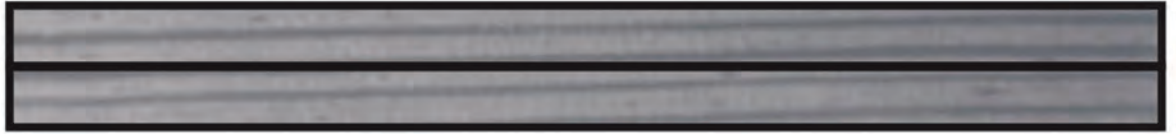

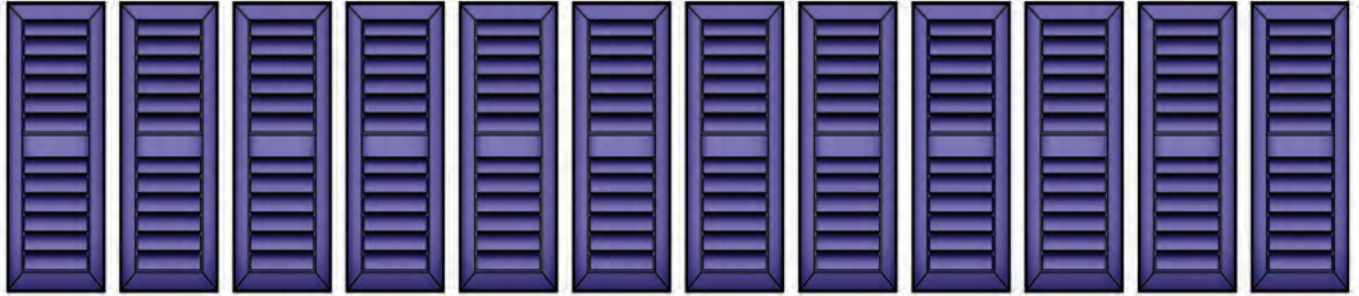
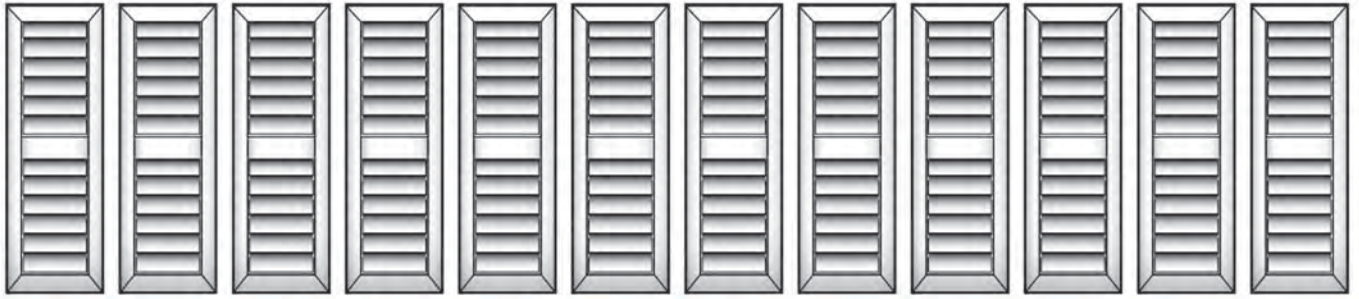

Furniture

Kitchen Fixtures

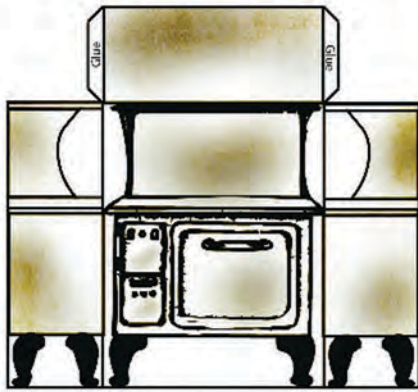

Living Room Fixtures

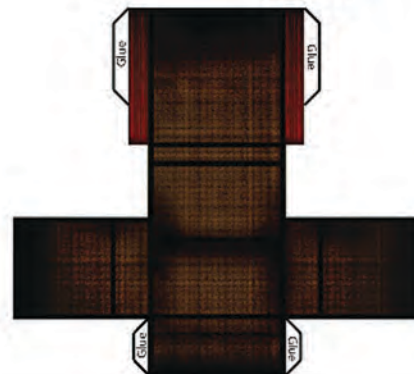
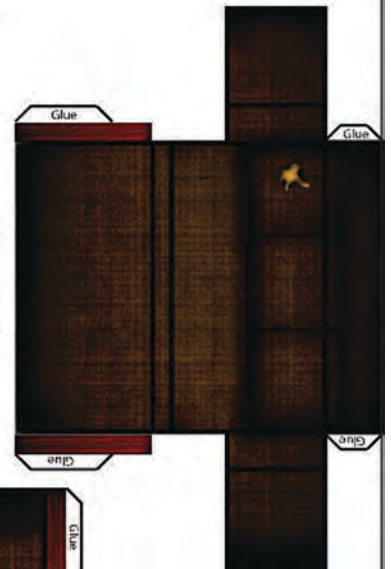
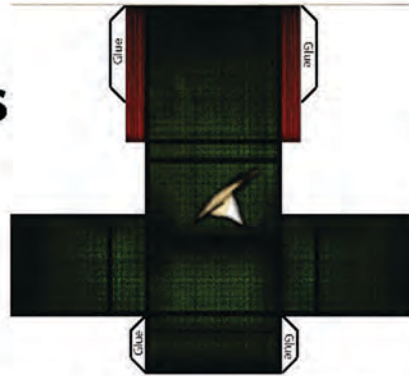

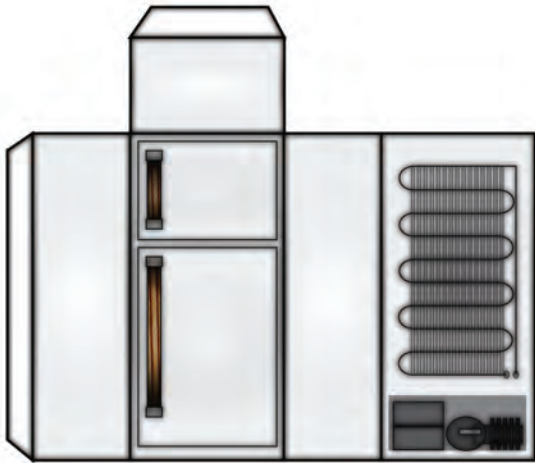
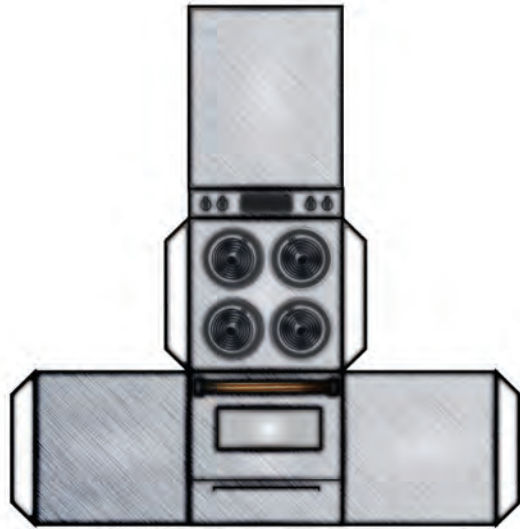
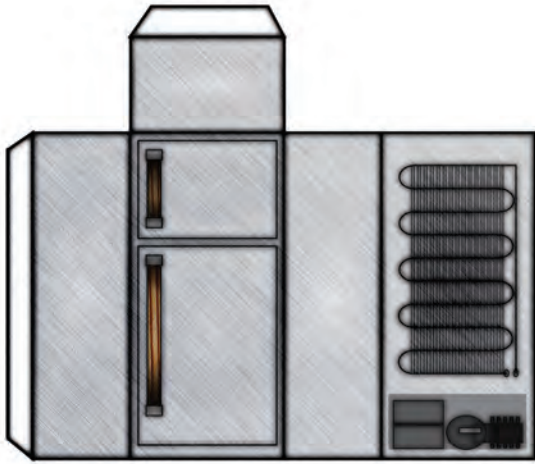

NOTICE

All images contained within this product are copyright of Carl R. Stoelzel. Print permissions granted to the purchaser only. Please do not freely redistribute any of these images.



Bathroom Fixtures

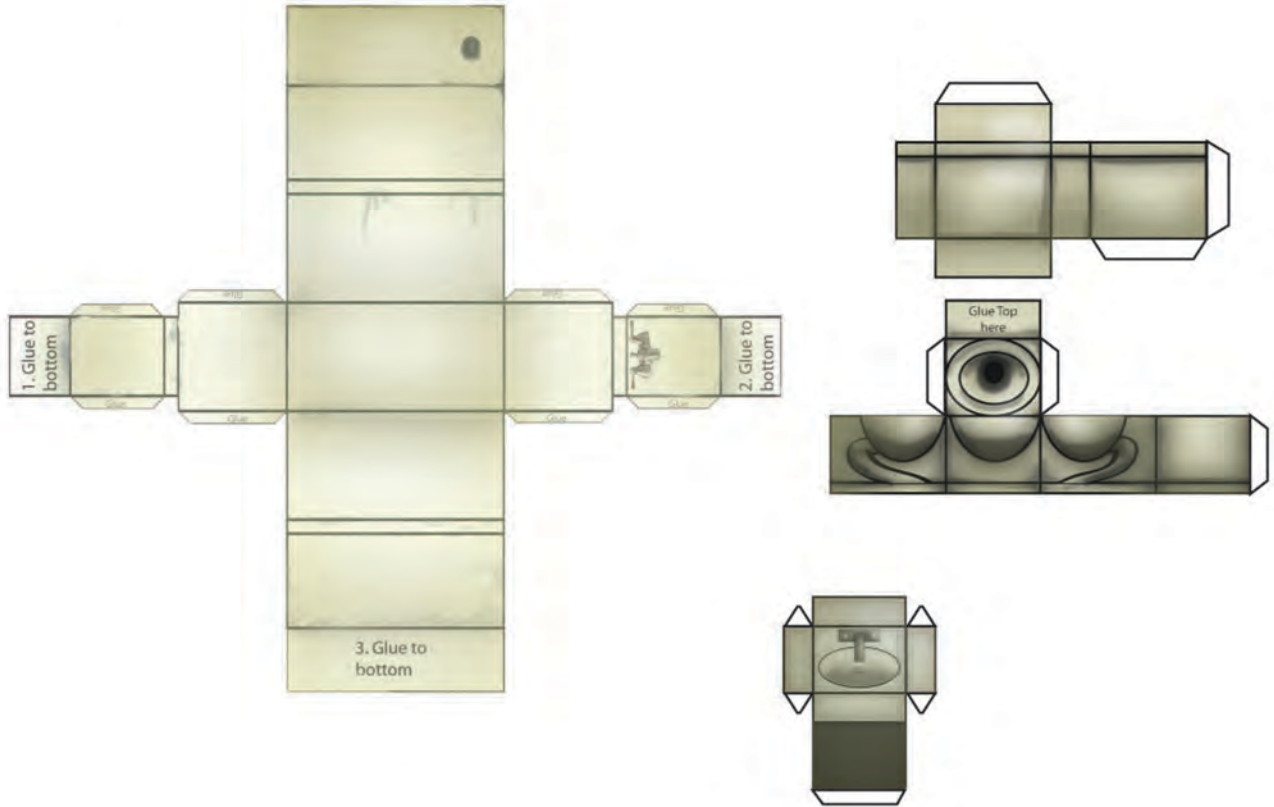

Bedroom Fixtures



NOTICE

All images contained within this product are copyright of Carl R. Stoezel. Print permissions granted to the purchaser only. Please do not freely redistribute any of these images.



Re-paints

A

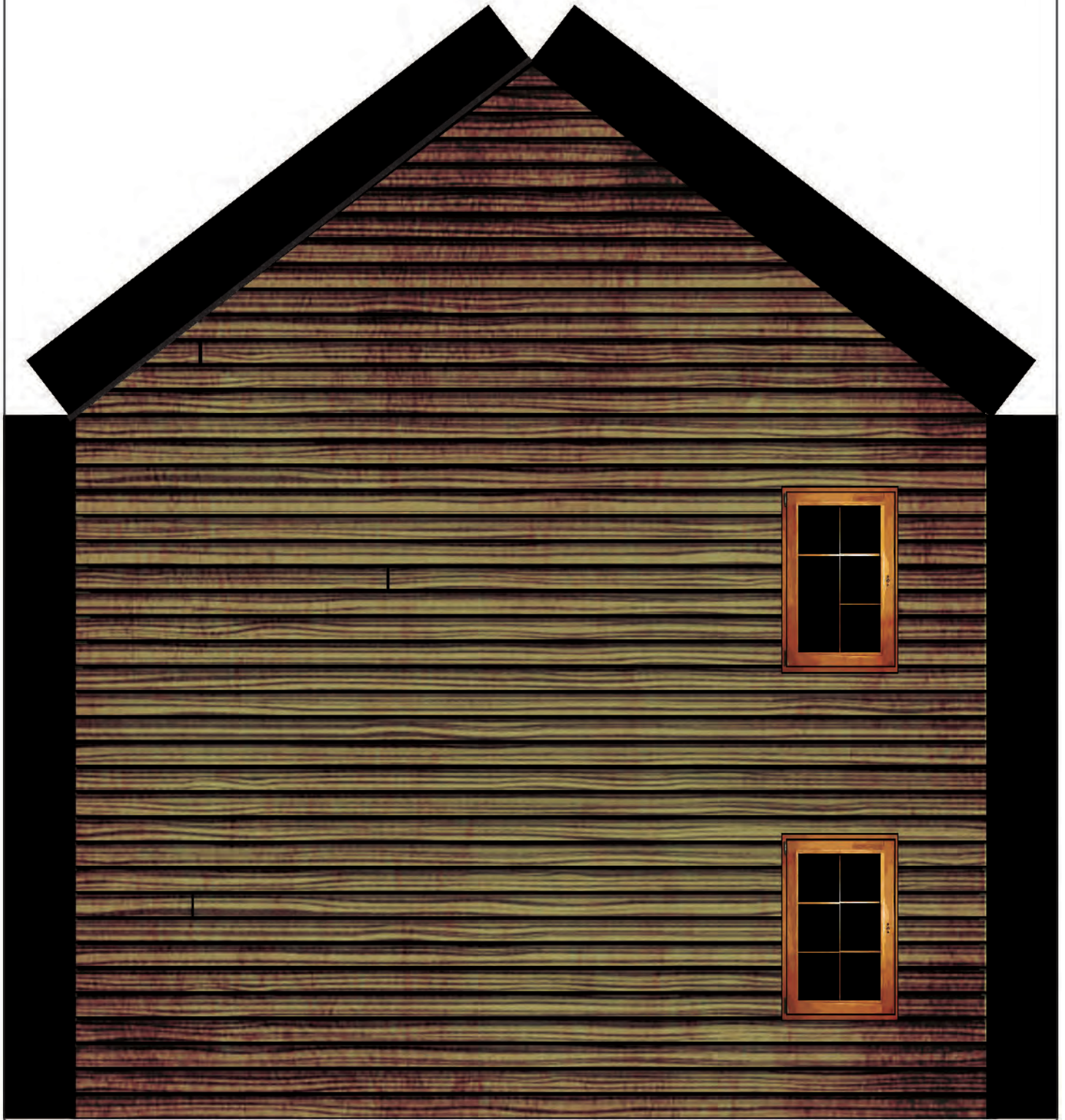

NOTICE

All images contained within this product are copyright of Carl R. Stoelzel. Print permissions granted to the purchaser only. Please do not freely redistribute any of these images.



A

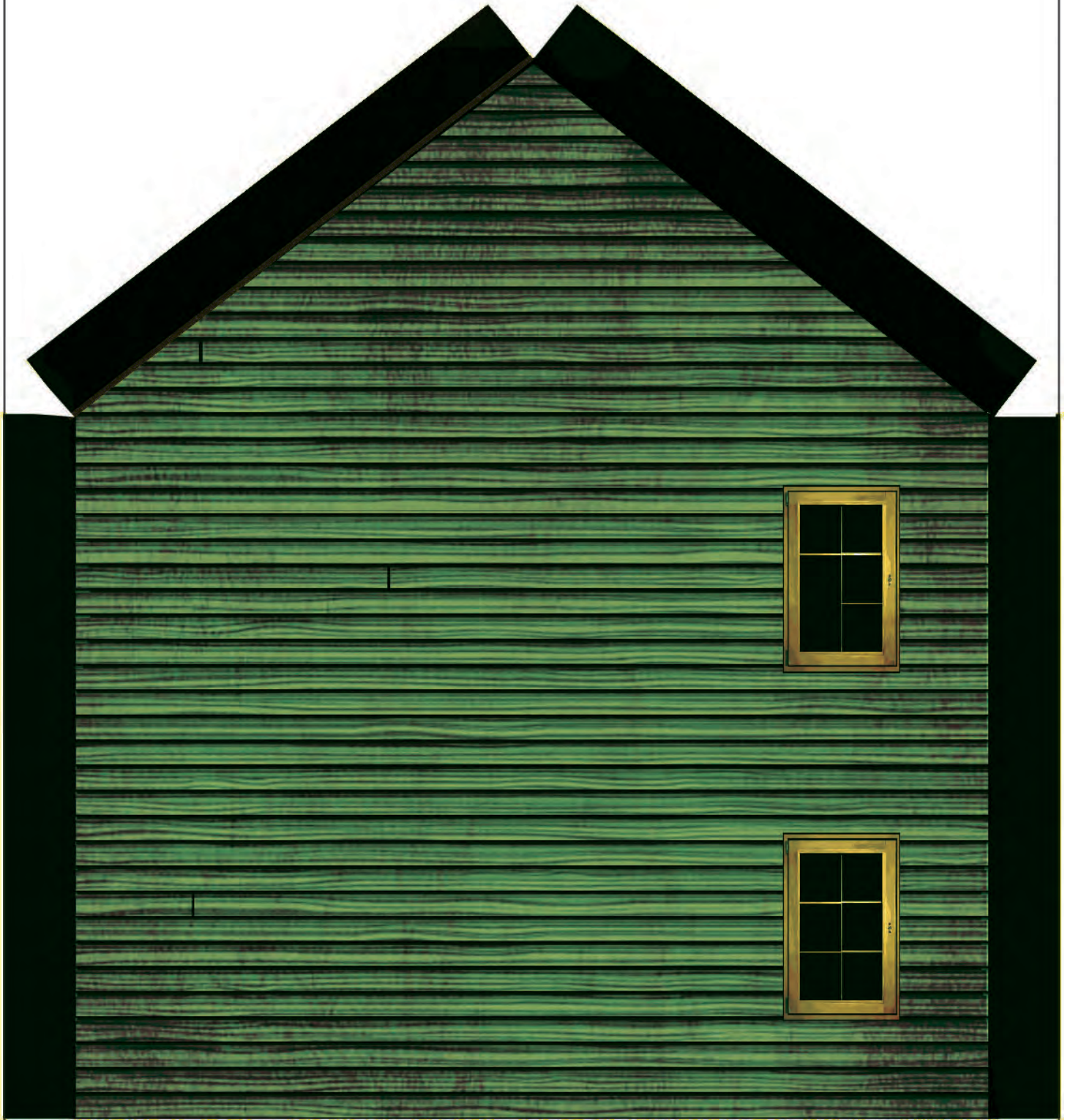

NOTICE

All images contained within this product are copyright of Carl R. Stoelzel.
Print permissions granted to the purchaser only. Please do not freely
redistribute any of these images.



A

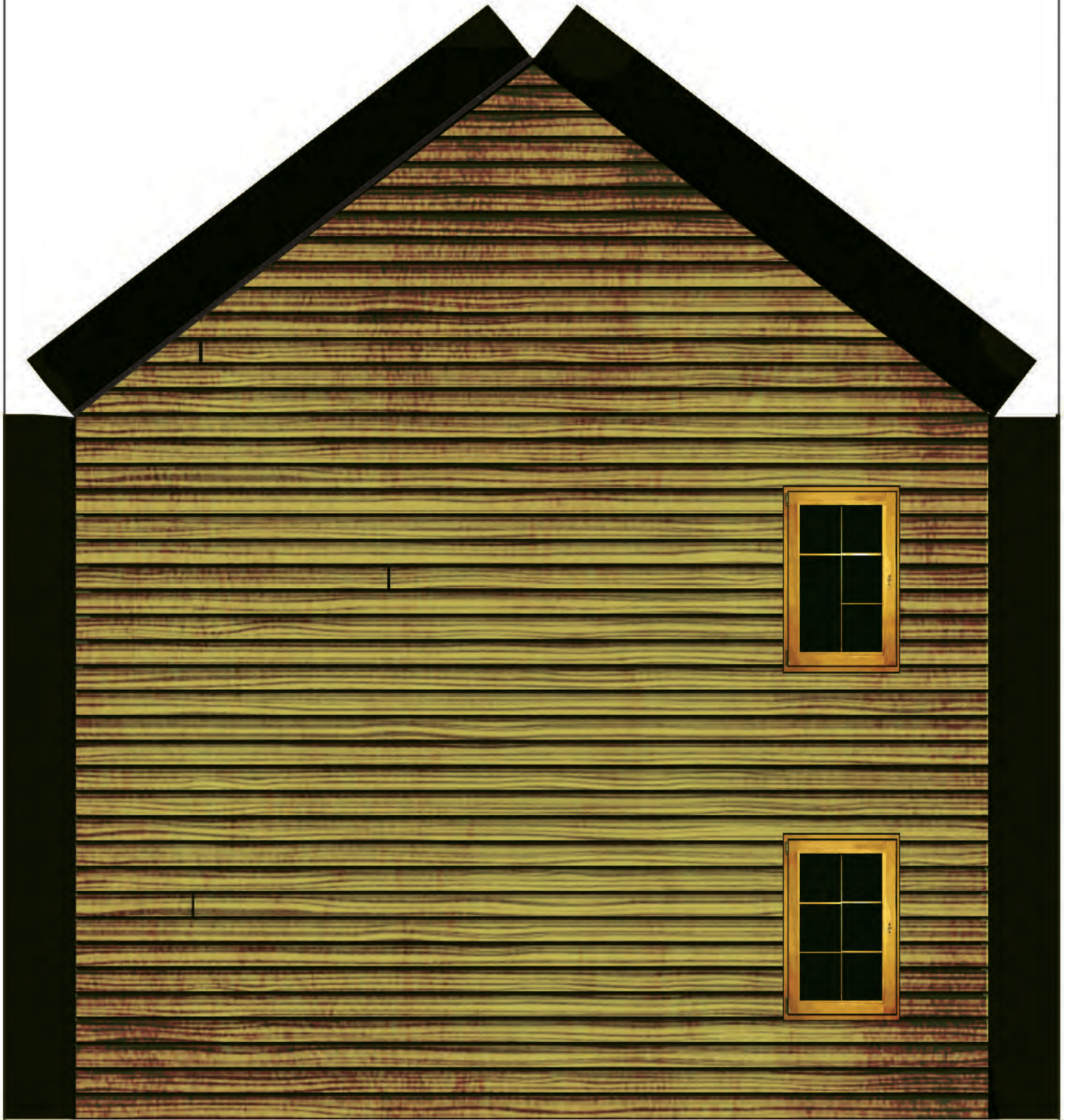

NOTICE

All images contained within this product are copyright of Carl R. Stoelzel.
Print permissions granted to the purchaser only. Please do not freely
redistribute any of these images.



C



NOTICE

All images contained within this product are copyright of Carl R. Stoezel. Print permissions granted to the purchaser only. Please do not freely redistribute any of these images.



C

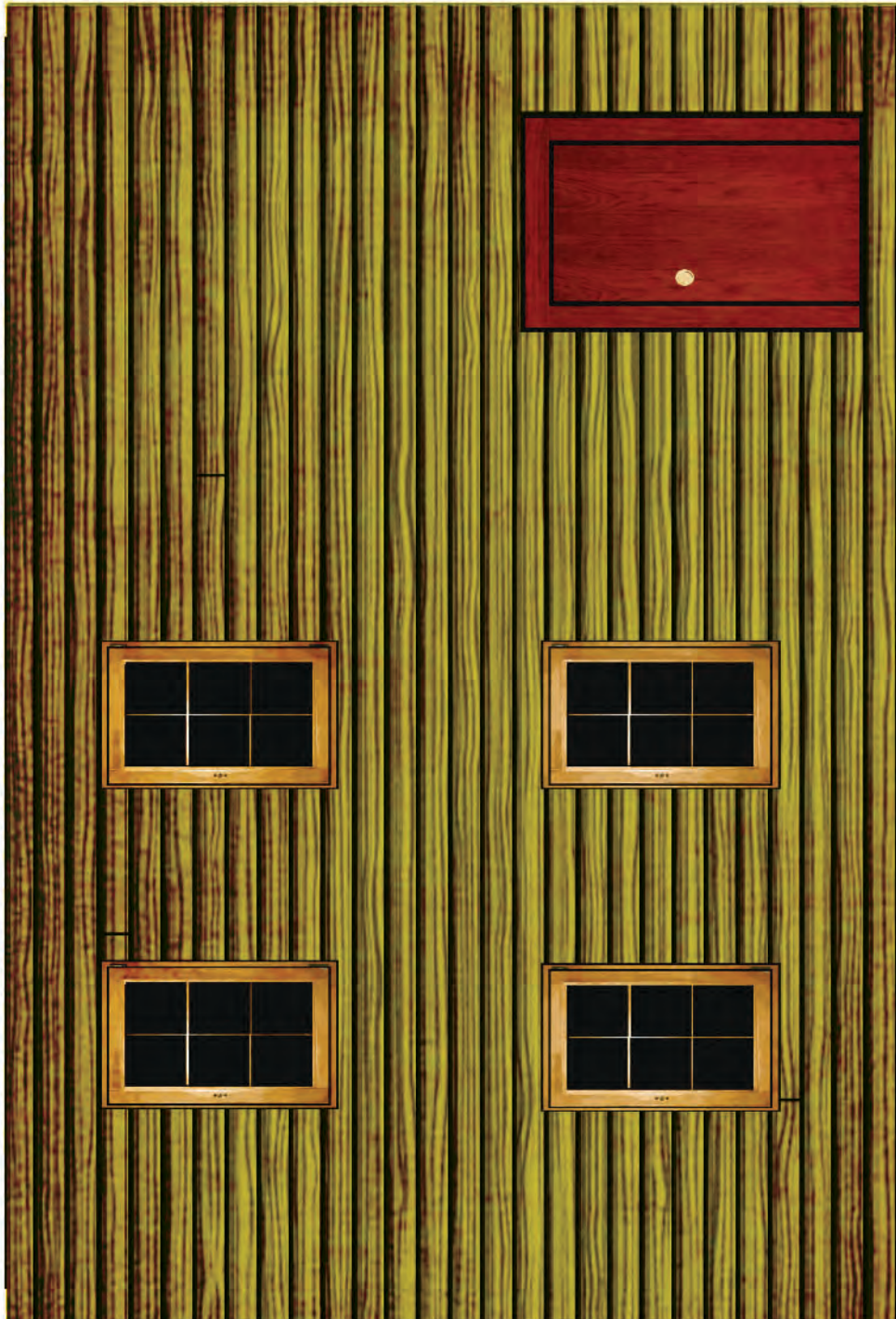

NOTICE

All images contained within this product are copyright of Carl R. Stoelzel. Print permissions granted to the purchaser only. Please do not freely redistribute any of these images.



C

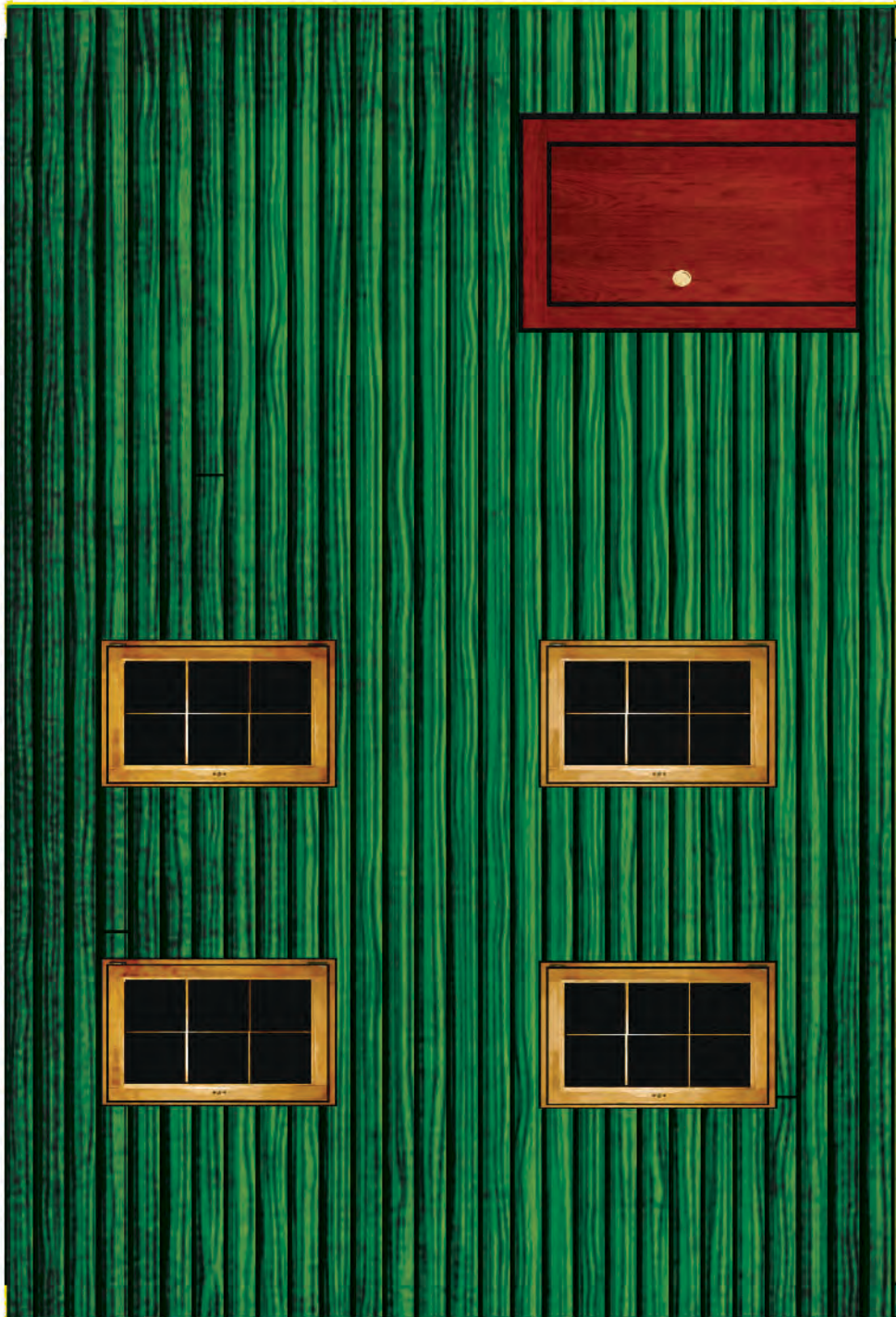

NOTICE

All images contained within this product are copyright of Carl R. Stoelzel. Print permissions granted to the purchaser only. Please do not freely redistribute any of these images.



E



NOTICE

All images contained within this product are copyright of Carl R. Stoelzel.
Print permissions granted to the purchaser only. Please do not freely
redistribute any of these images.



E



NOTICE

All images contained within this product are copyright of Carl R. Stoelzel.
Print permissions granted to the purchaser only. Please do not freely
redistribute any of these images.



E



NOTICE

All images contained within this product are copyright of Carl R. Stoelzel.
Print permissions granted to the purchaser only. Please do not freely
redistribute any of these images.



G



NOTICE

All images contained within this product are copyright of Carl R. Stoelzel. Print permissions granted to the purchaser only. Please do not freely redistribute any of these images.



G



NOTICE

All images contained within this product are copyright of Carl R. Stoelzel. Print permissions granted to the purchaser only. Please do not freely redistribute any of these images.



G



NOTICE

All images contained within this product are copyright of Carl R. Stoelzel. Print permissions granted to the purchaser only. Please do not freely redistribute any of these images.



S

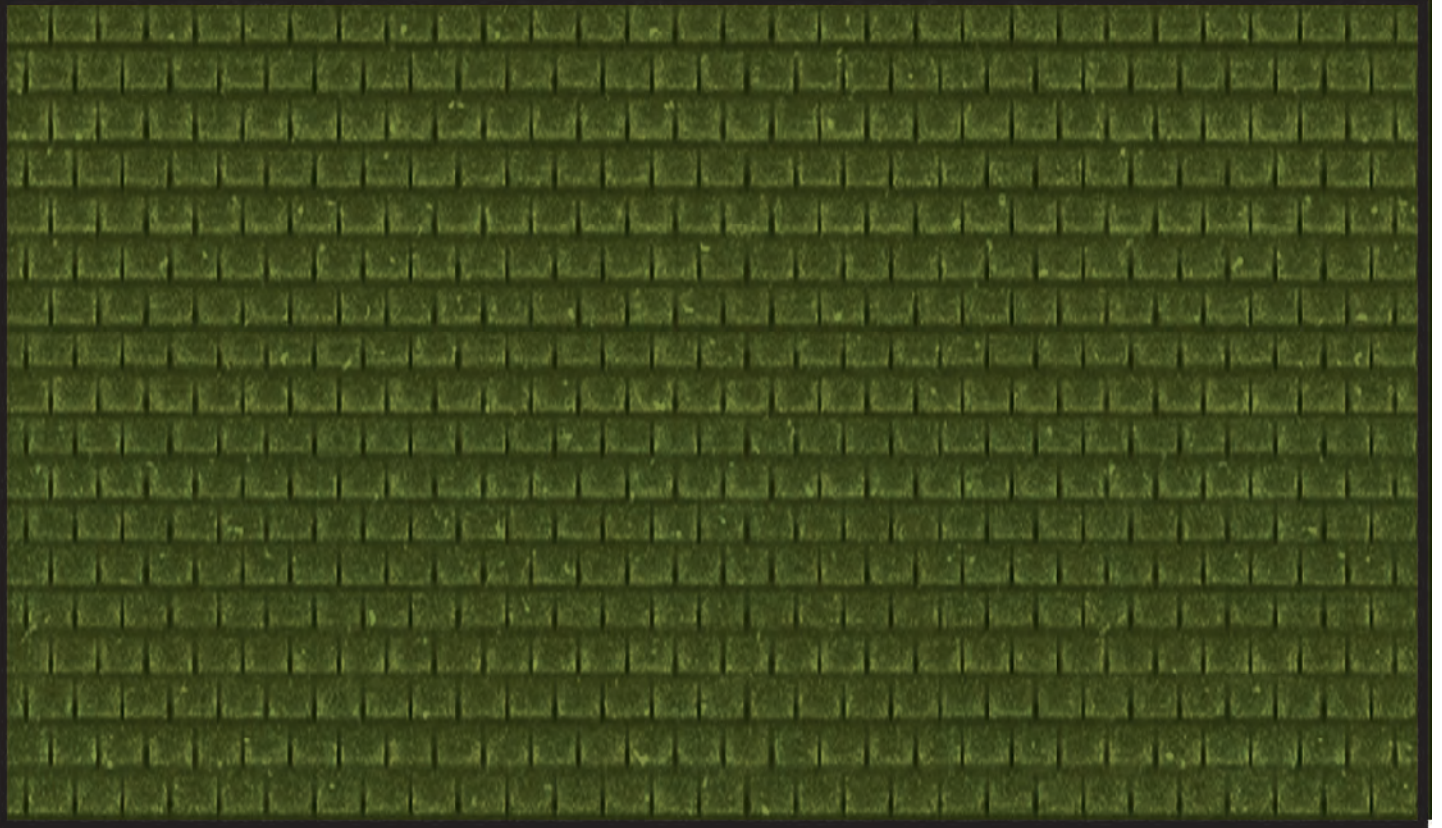
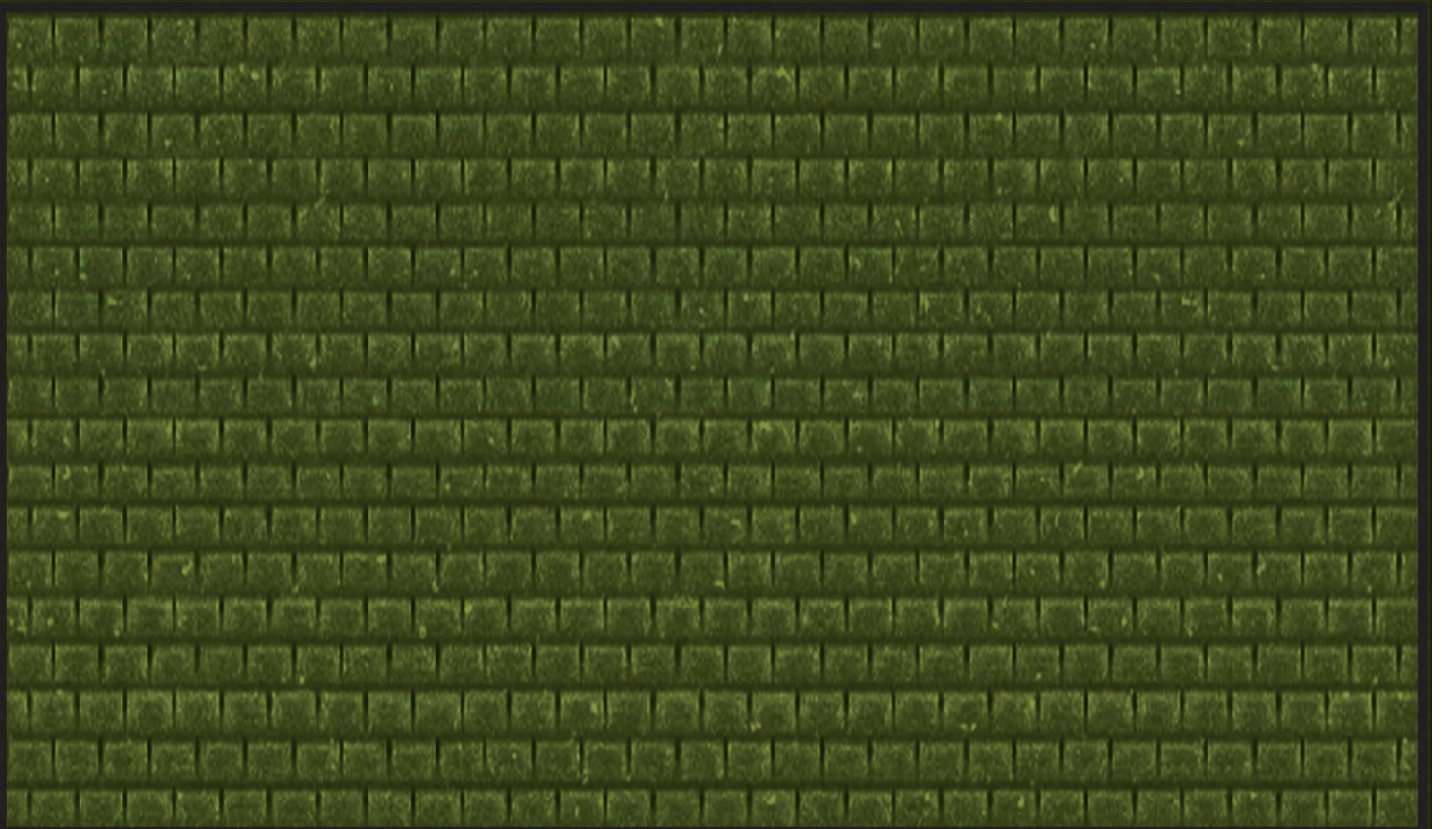

S

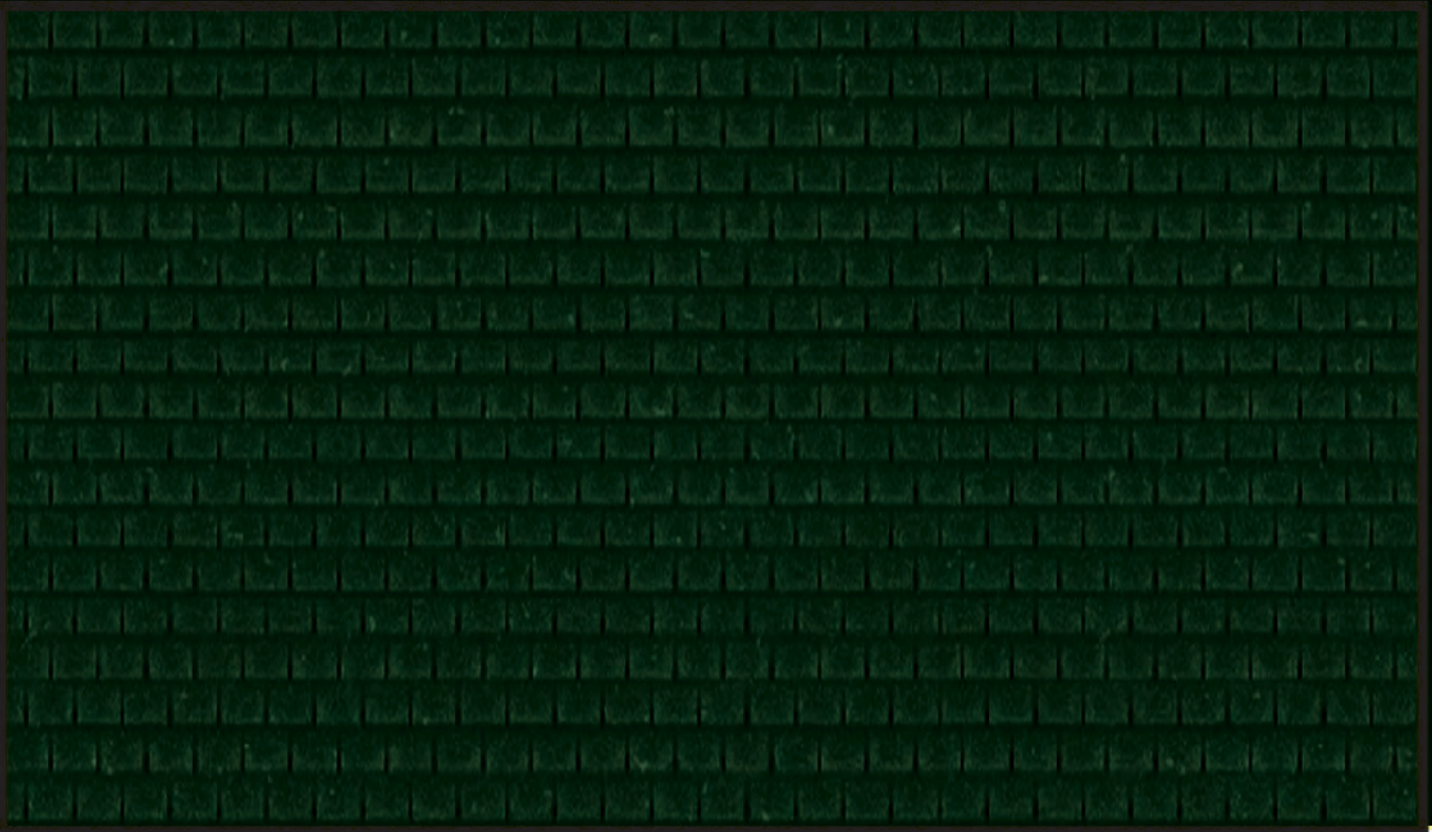

A

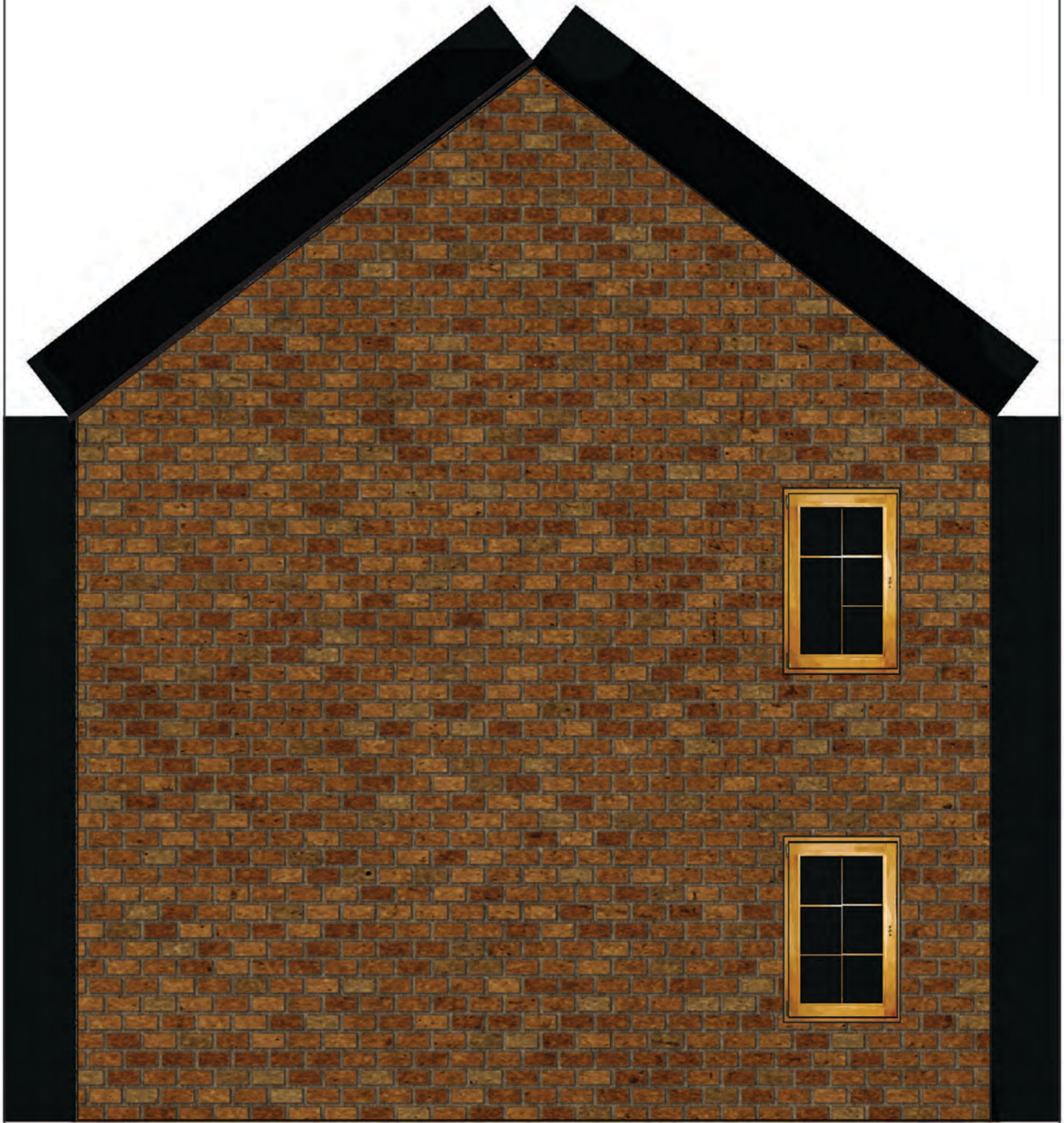

NOTICE

All images contained within this product are copyright of Carl R. Stoelzel.
Print permissions granted to the purchaser only. Please do not freely
redistribute any of these images.



C

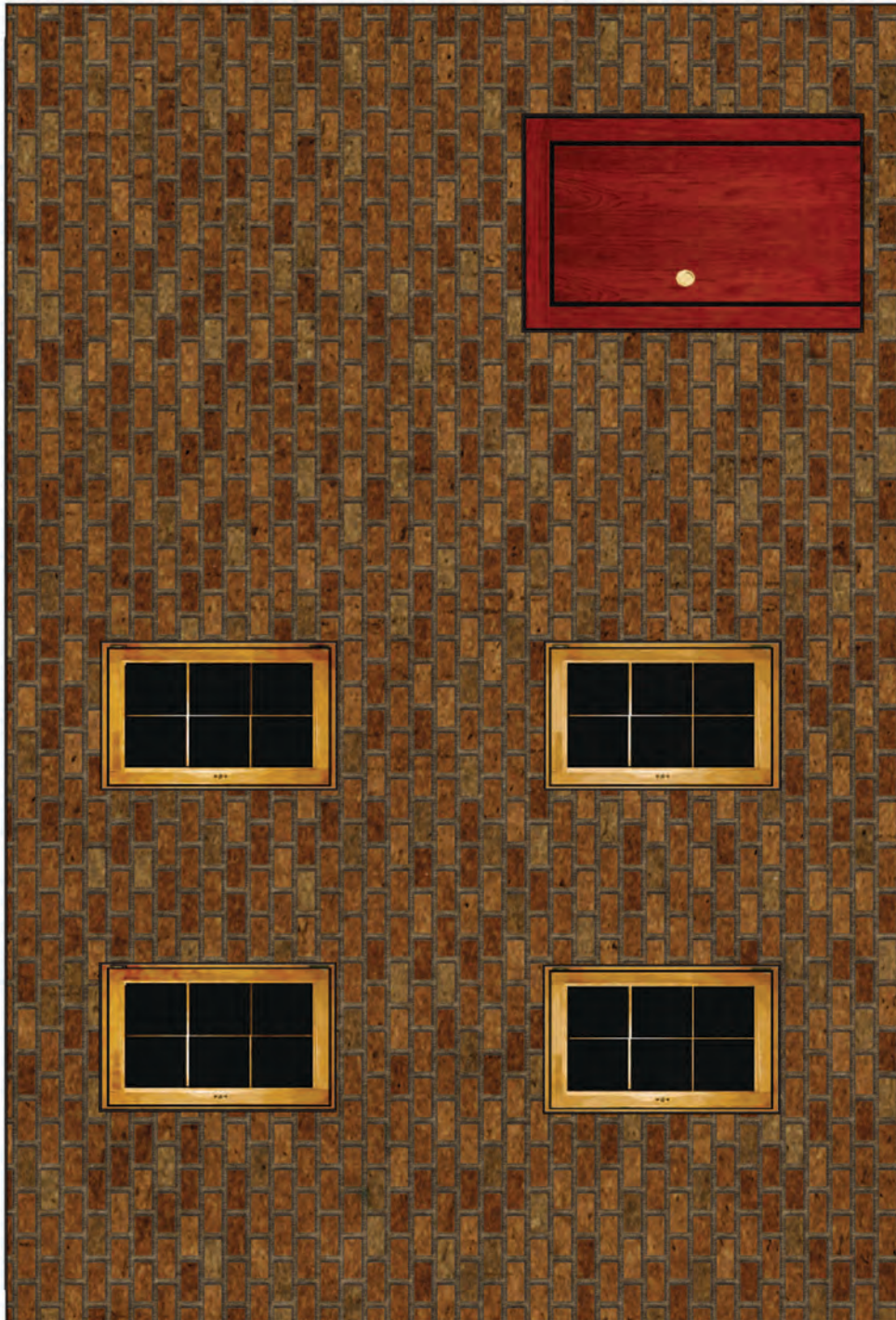

NOTICE

All images contained within this product are copyright of Carl R. Stoelzel. Print permissions granted to the purchaser only. Please do not freely redistribute any of these images.



E

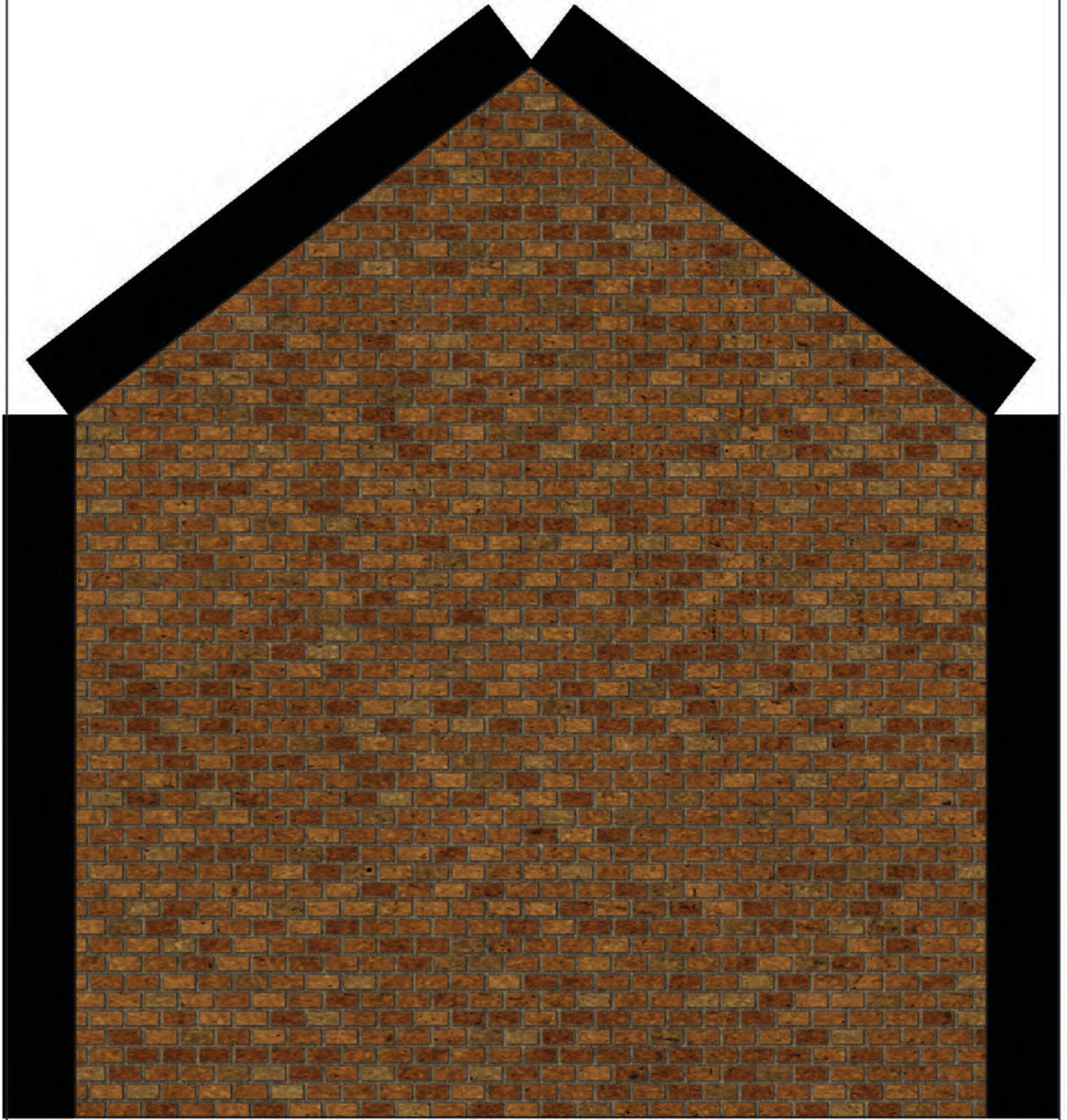

NOTICE

All images contained within this product are copyright of Carl R. Stoelzel.
Print permissions granted to the purchaser only. Please do not freely
redistribute any of these images.



G



NOTICE

All images contained within this product are copyright of Carl R. Stoelzel.
Print permissions granted to the purchaser only. Please do not freely
redistribute any of these images.



A

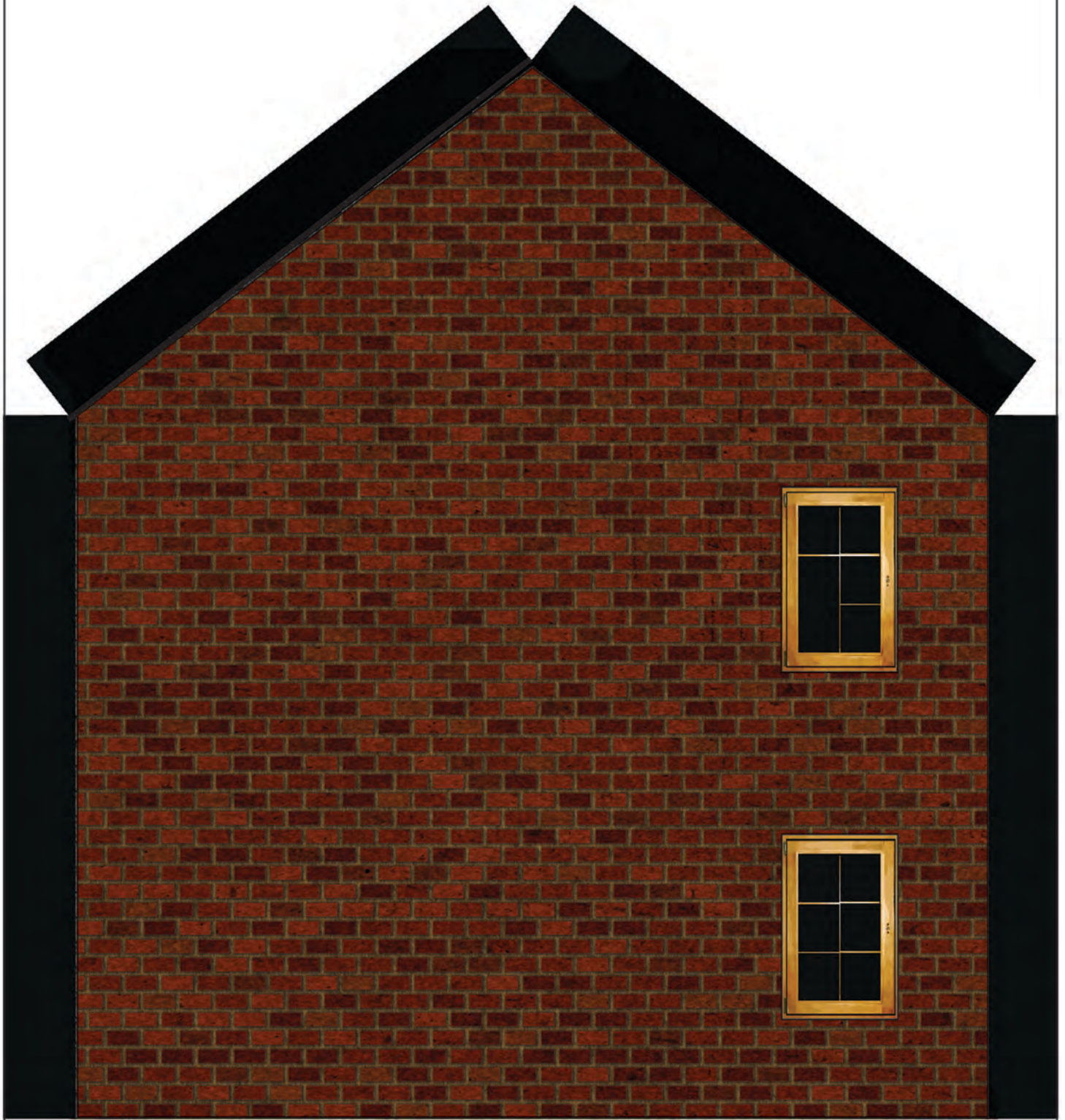

NOTICE

All images contained within this product are copyright of Carl R. Stoelzel.
Print permissions granted to the purchaser only. Please do not freely
redistribute any of these images.



C

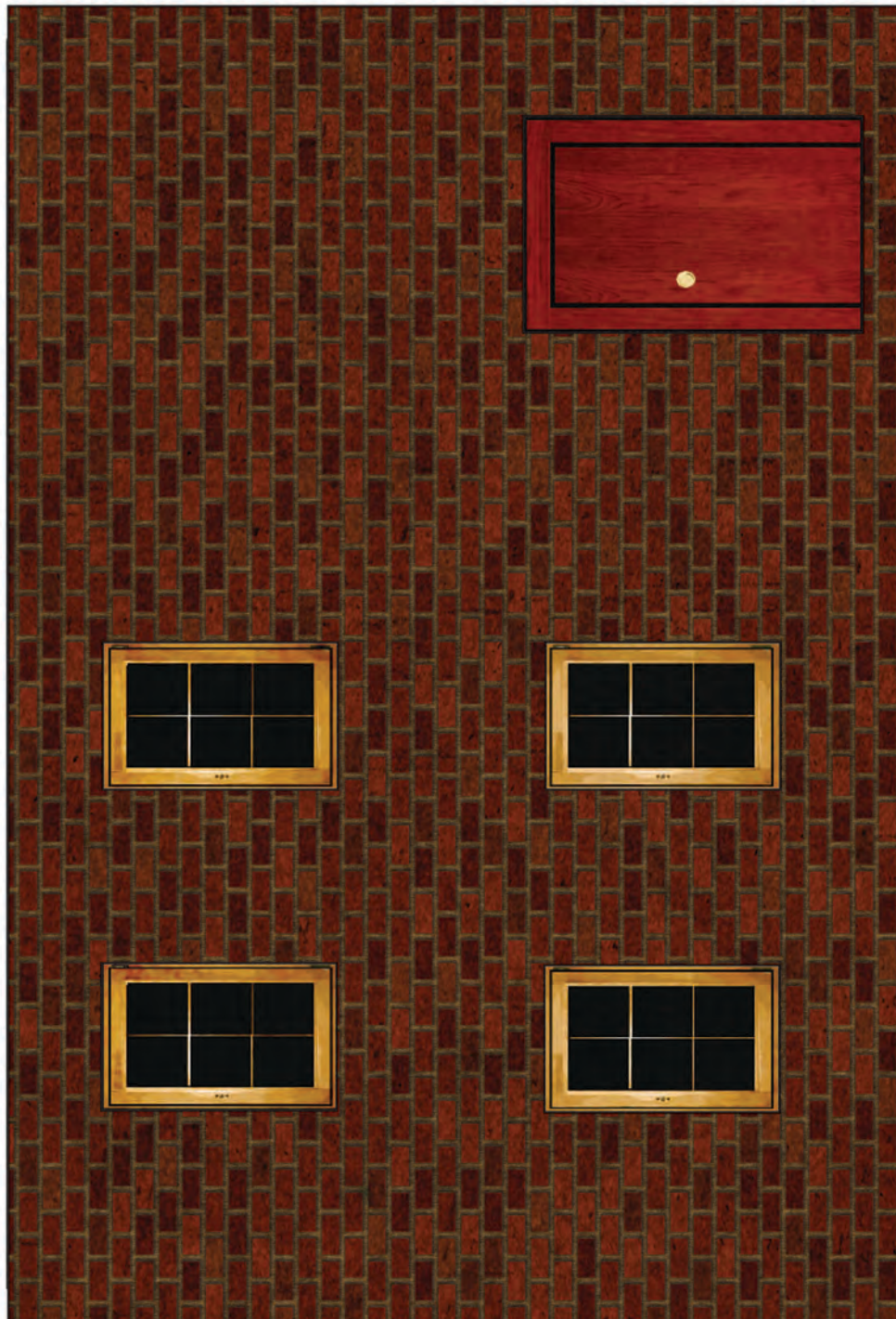

NOTICE

All images contained within this product are copyright of Carl R. Stoelzel. Print permissions granted to the purchaser only. Please do not freely redistribute any of these images.



E

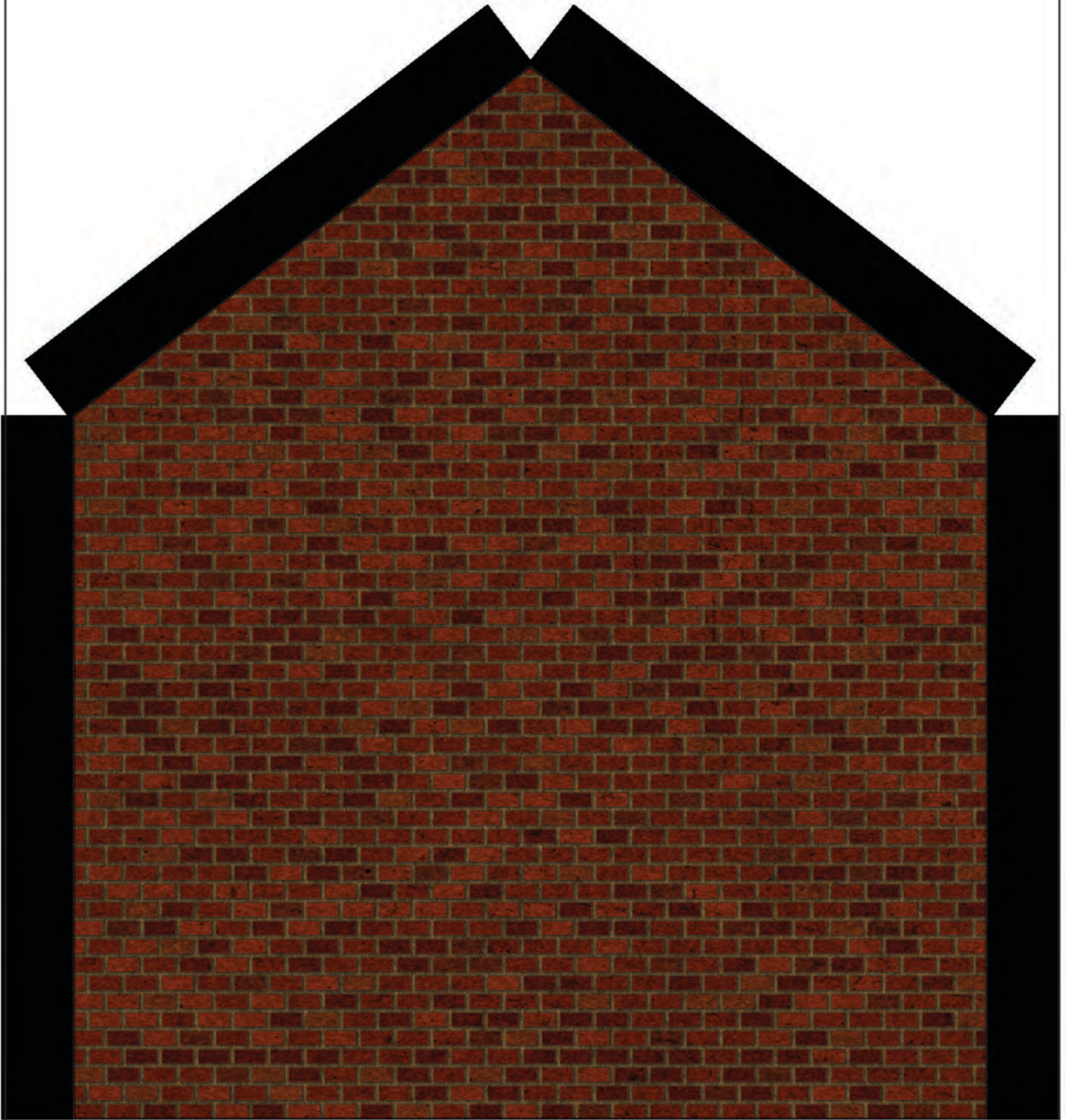

NOTICE

All images contained within this product are copyright of Carl R. Stoelzel.
Print permissions granted to the purchaser only. Please do not freely
redistribute any of these images.



G

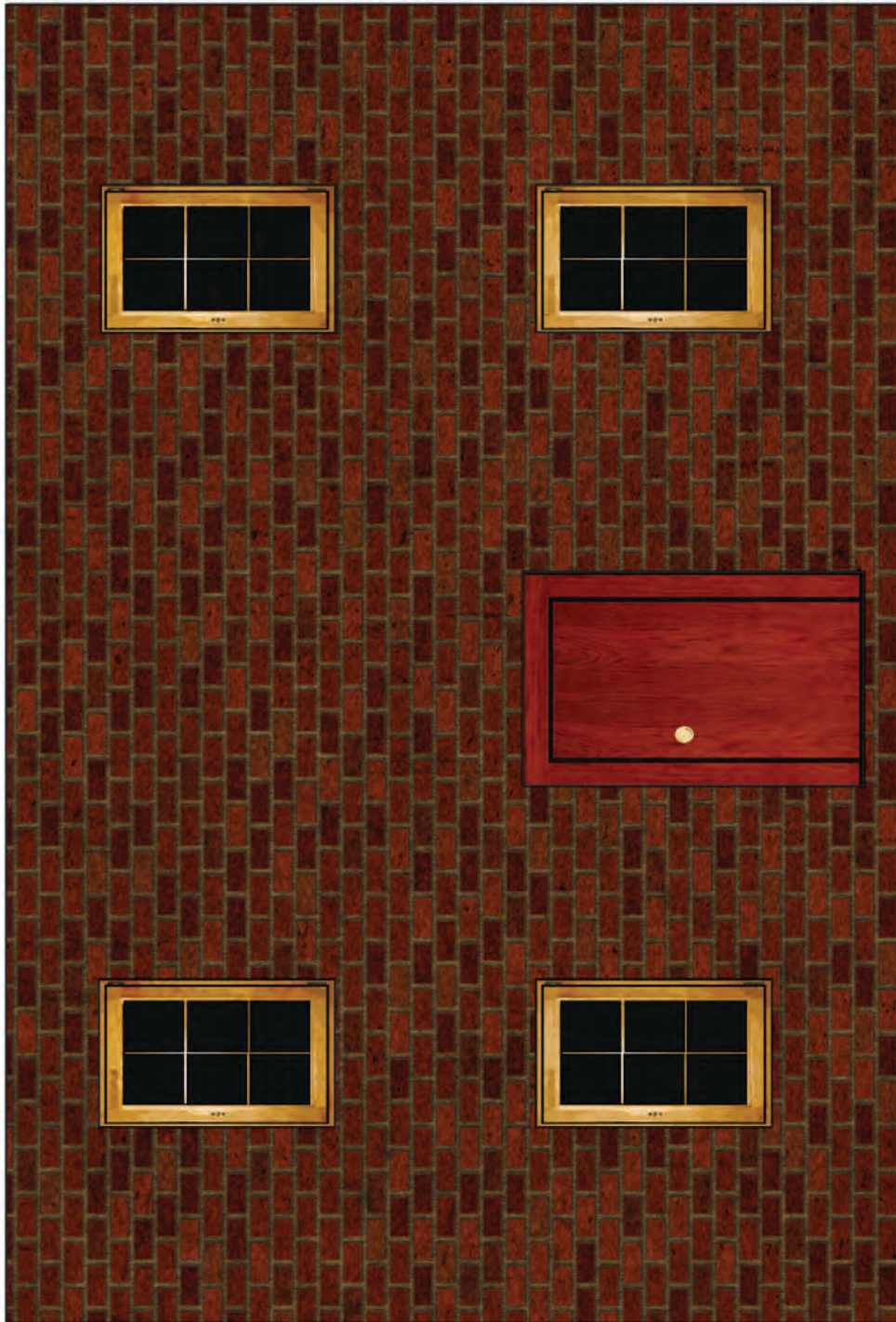

NOTICE

All images contained within this product are copyright of Carl R. Stoelzel.
Print permissions granted to the purchaser only. Please do not freely
redistribute any of these images.



A



NOTICE

All images contained within this product are copyright of Carl R. Stoelzel.
Print permissions granted to the purchaser only. Please do not freely
redistribute any of these images.



C



NOTICE

All images contained within this product are copyright of Carl R. Stoelzel. Print permissions granted to the purchaser only. Please do not freely redistribute any of these images.



E

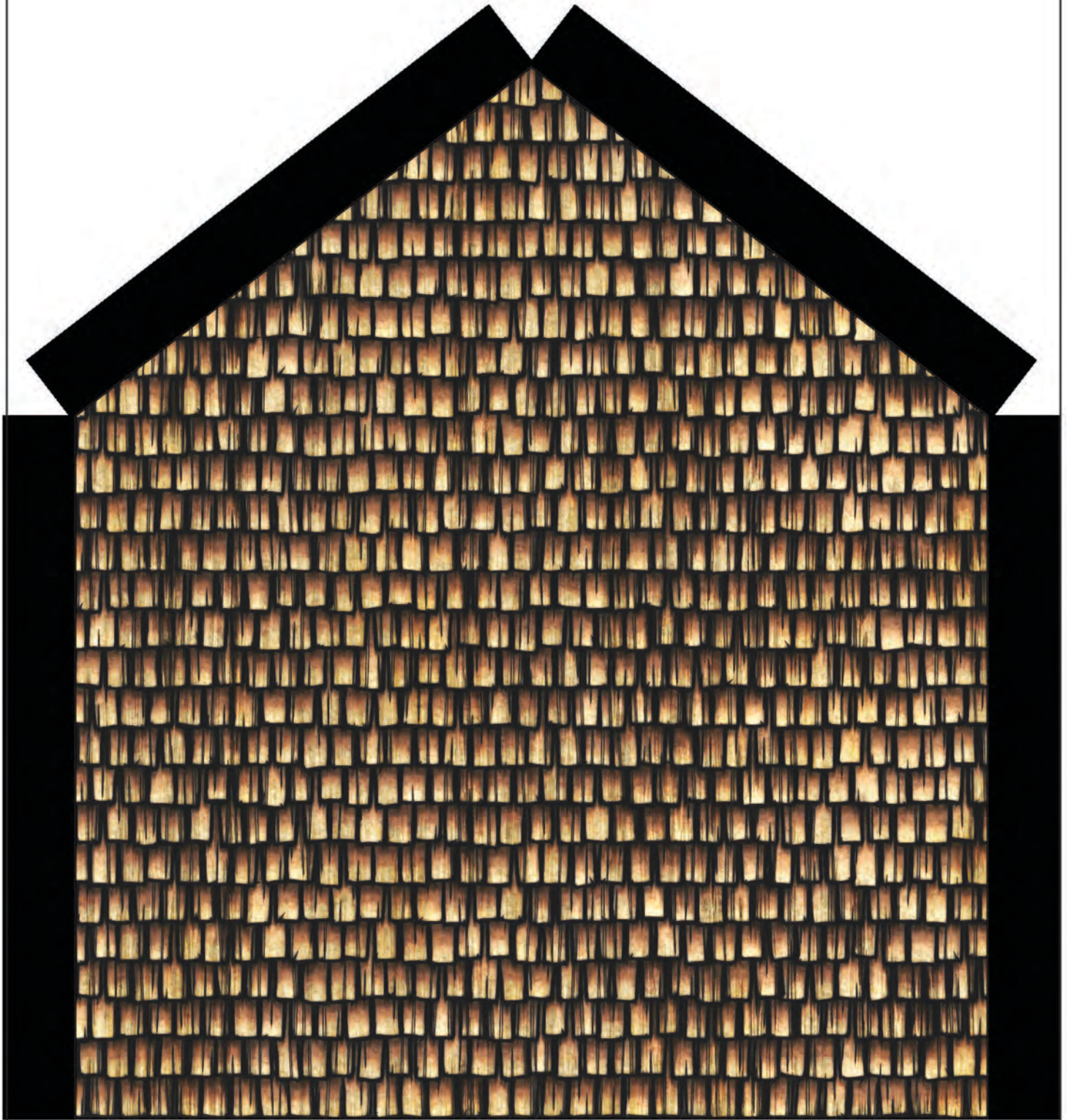

NOTICE

All images contained within this product are copyright of Carl R. Stoelzel.
Print permissions granted to the purchaser only. Please do not freely
redistribute any of these images.



G



NOTICE

All images contained within this product are copyright of Carl R. Stoelzel.
Print permissions granted to the purchaser only. Please do not freely
redistribute any of these images.



Corner Wrappers

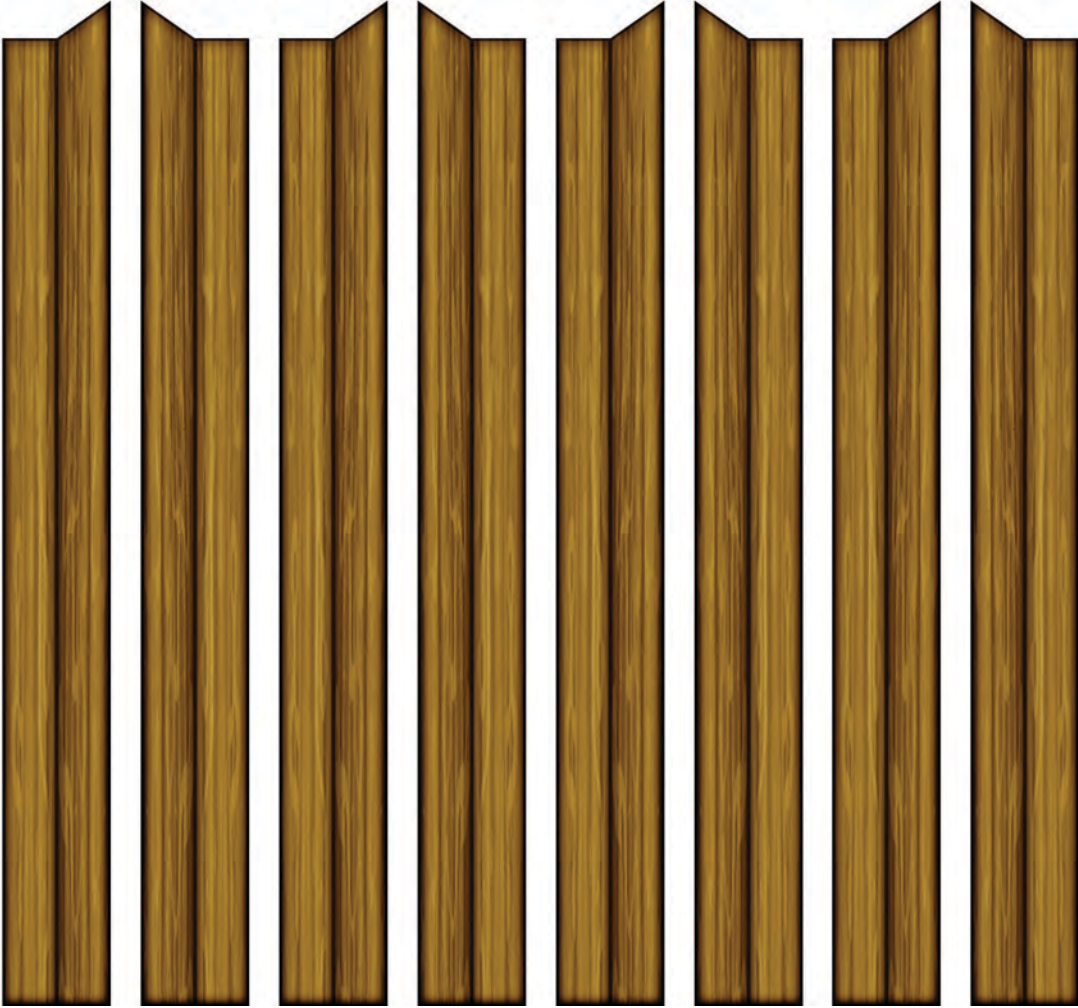

Tables, Dressers, Toy boxes, etc.

Tables are a simple cube once assembled. Fold along the four black lines that separate the top of the table (found in the middle) from the four sides. Then fold the four white tabs ninety degrees so that they tuck under the sides of the table. Put a drop of glue on the white tabs to permanently fix in place.

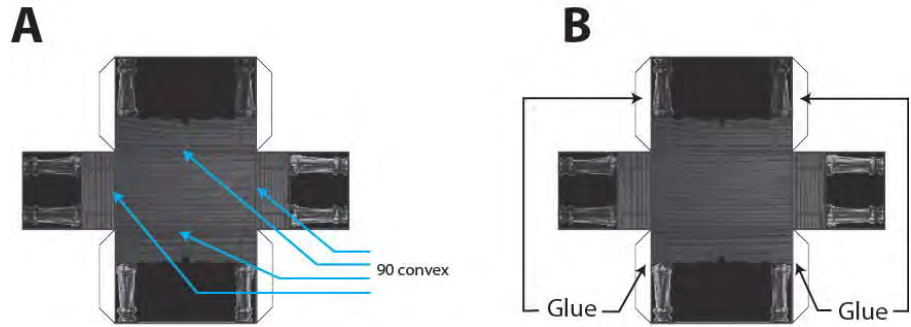

Cut out the circular wooden table topper and simply glue on top of the table.

Sink

Sinks are a simple cube once assembled. Fold along the four black lines that separate the (found in the middle) from the four sides. Then fold the four white tabs ninety degrees so that they tuck under the sides of the sink. Put a drop of glue on the white tabs to permanently fix in place. Glue on to the wall where desired.

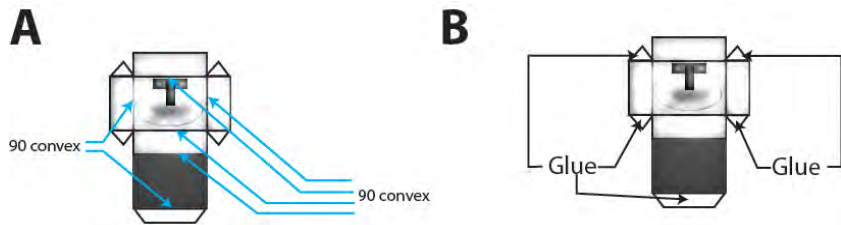

Toilets

Toilets come into two pieces, a bottom and a top, but both pieces are a simple cube once assembled. Fold along the four black lines that separate the front (found in the middle) from the sides, top and bottom. Then fold the four white tabs ninety degrees so that they tuck under the sides of the table. Put a drop of glue on the white tabs to permanently fix in place. Glue the toilet top on top of the toilet bottom.

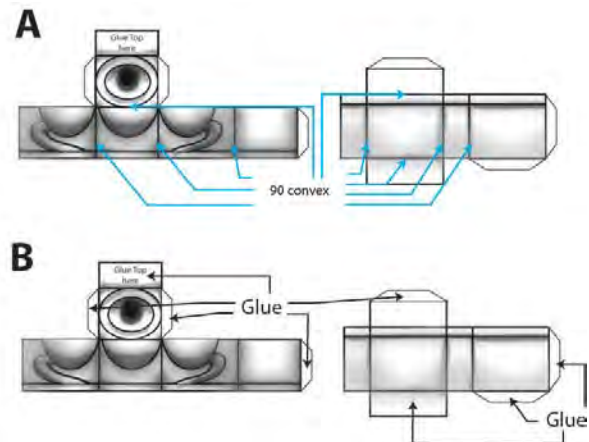

Television/Computer monitor.

The TV is not that different from the other simple cubes you've seen in this furniture set. The only departure is the back side, which is designed to stick out. You will see a small rectangle in the middle of the back, this part is going to be parallel with the front of the unit. The four sides which are adjacent will fall at roughly 45 degree angles, and come together at their seams. Use the tabs to glue together.

Piano.

The Piano is also a lot simpler than it might appear. It is, at heart, a simple cube. The only piece that you need to watch for is the keyboard, which will, when complete, face upward.

Couch and Soft Chairs.

The grey square in the middle of the piece is actually the bottom of the chair/couch, and will face the ground. The front, back and sides are adjacent and will fold upward, and face outward. The adjacent face going further out will be folded inward, and in the case of the back and sides, will be folded 180 degrees.

Lamps

The lamps consist of two parts: the base and the shade. The base is assembled by rolling the long cylinder and gluing it closed with the tab. The two circles fold over to cover the ends and glue shut using the tabs. The light bulb points up. The shade is assembled by rolling the long curve into a cone shape and glue the tab under the opposite end. Close the shade by folding the circle over and gluing the tabs under the shade. Glue the shade on top of the base.

Chairs

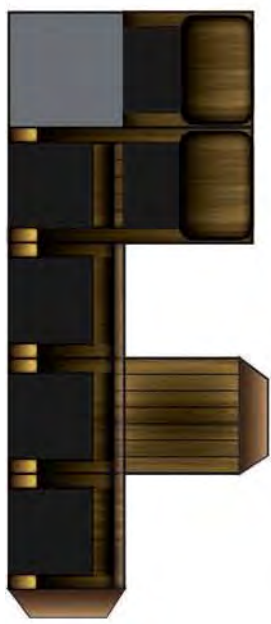
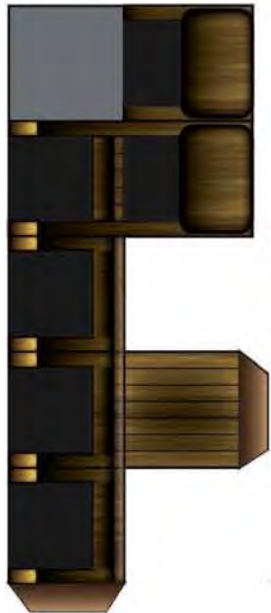
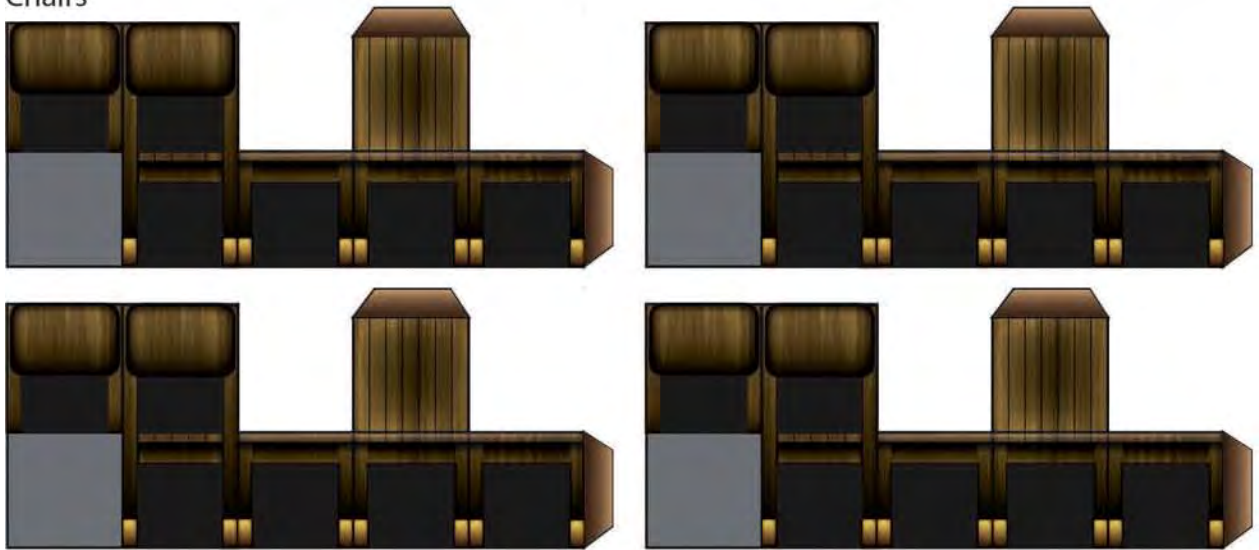

China Cabinet

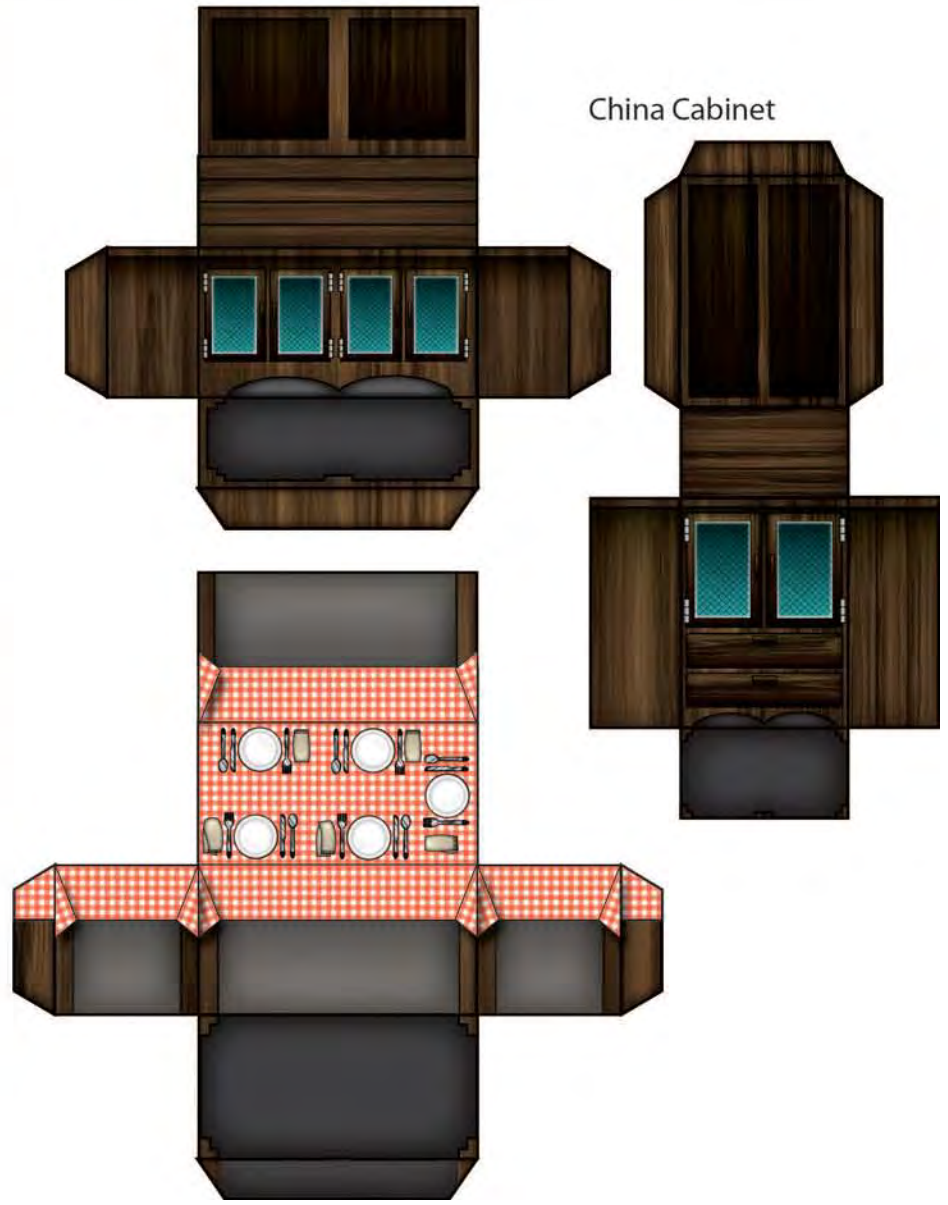

Table

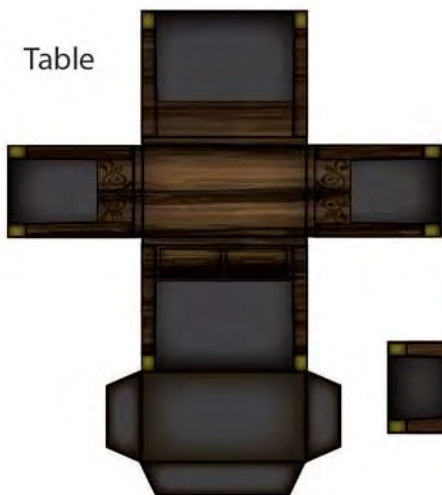

Coffee Table

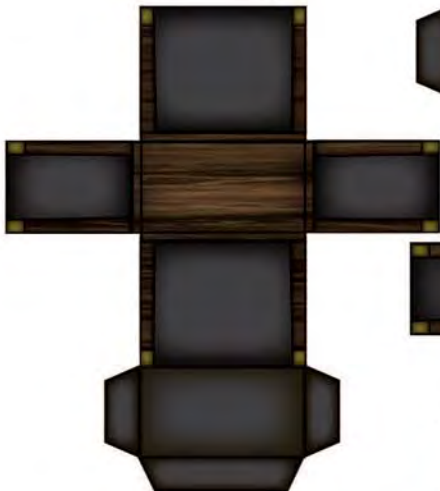

Night stands



Dressers



Toy boxes



Television set (less than modern tech)

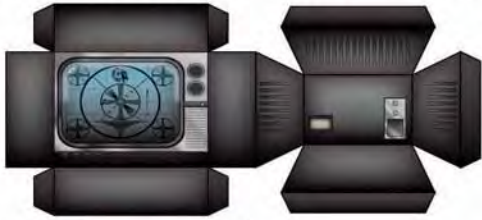

Piano



Washing machine



Alternate Stove

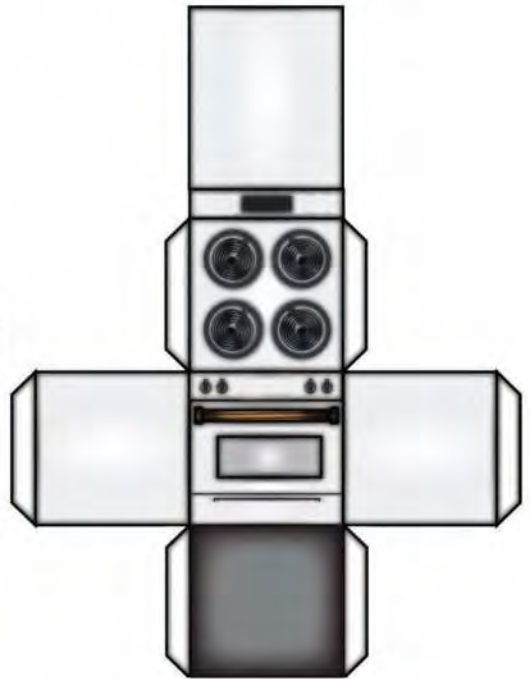

Simple bath tub

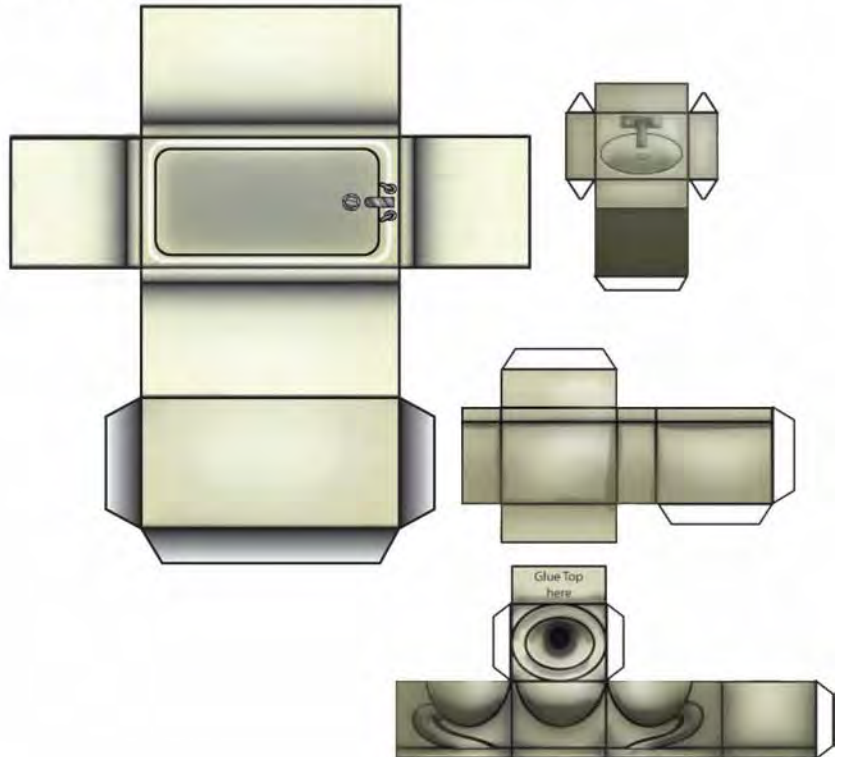

Desk



Lower Cabinet



Upper Cabinet



Upper Cabinet



Upper Cabinet



Lower Cabinet



Lower Cabinet



Lower Cabinet



Lower Cabinet



Upper Cabinet



Taller beds

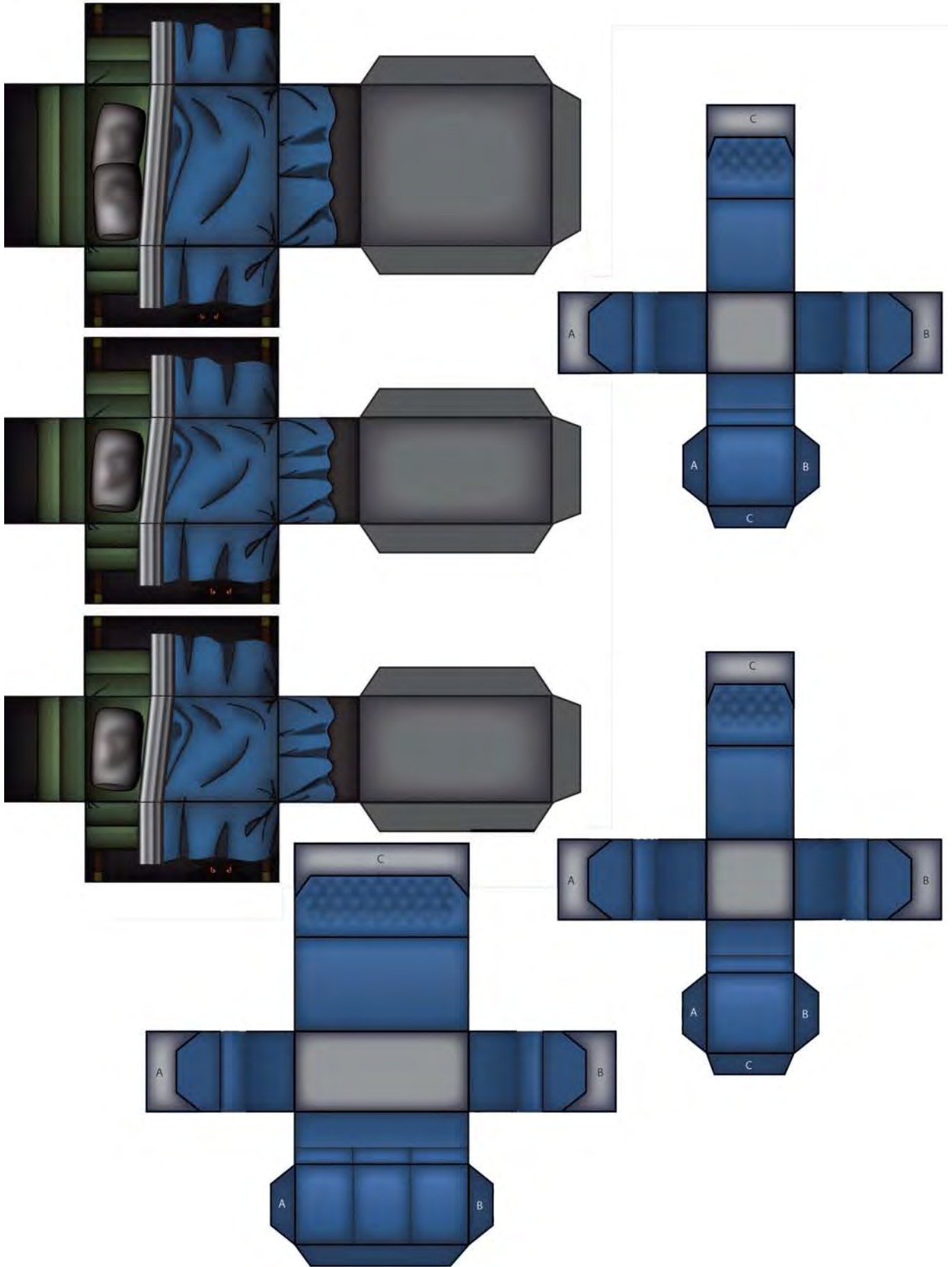

Taller beds

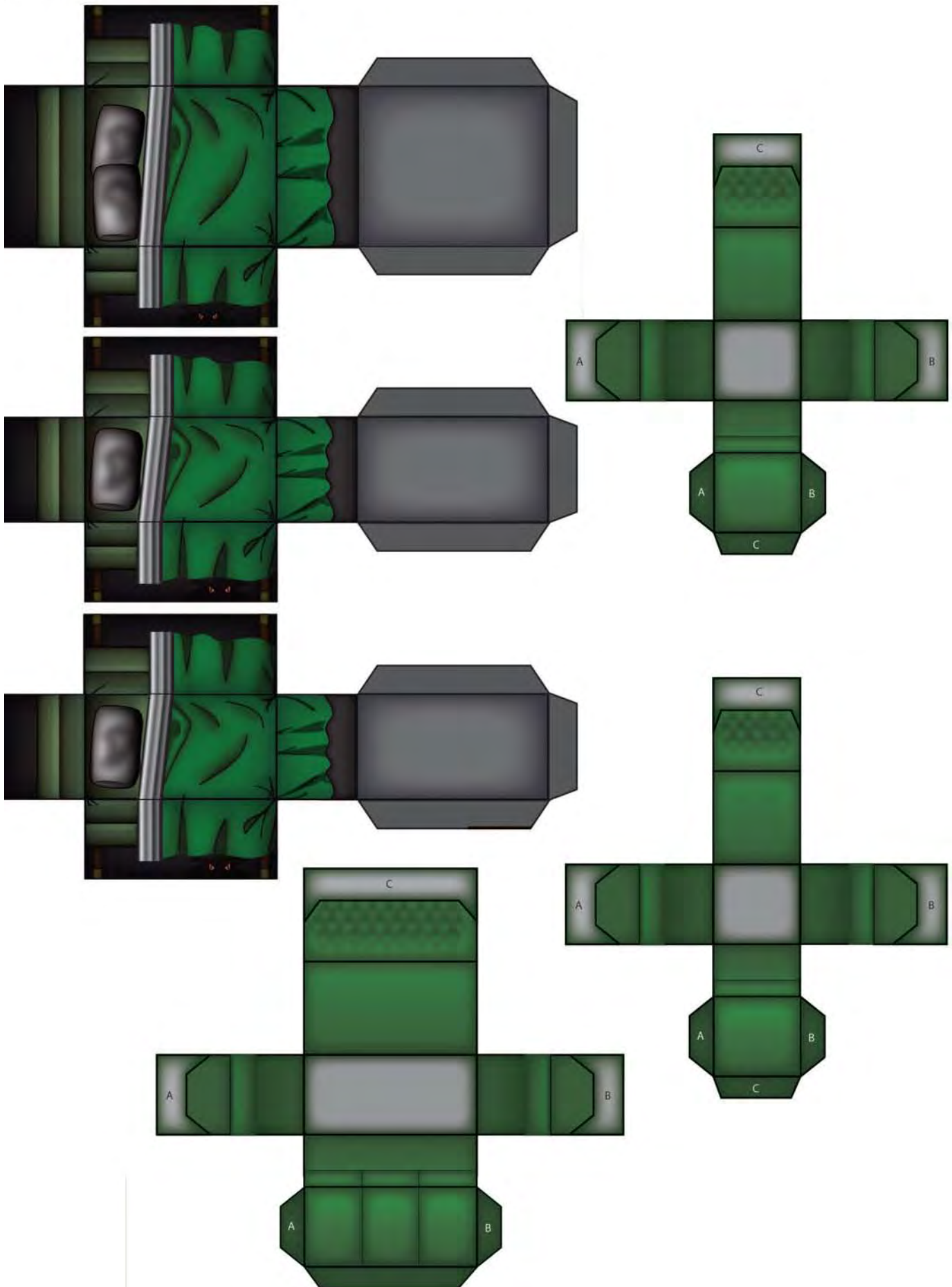

Taller beds

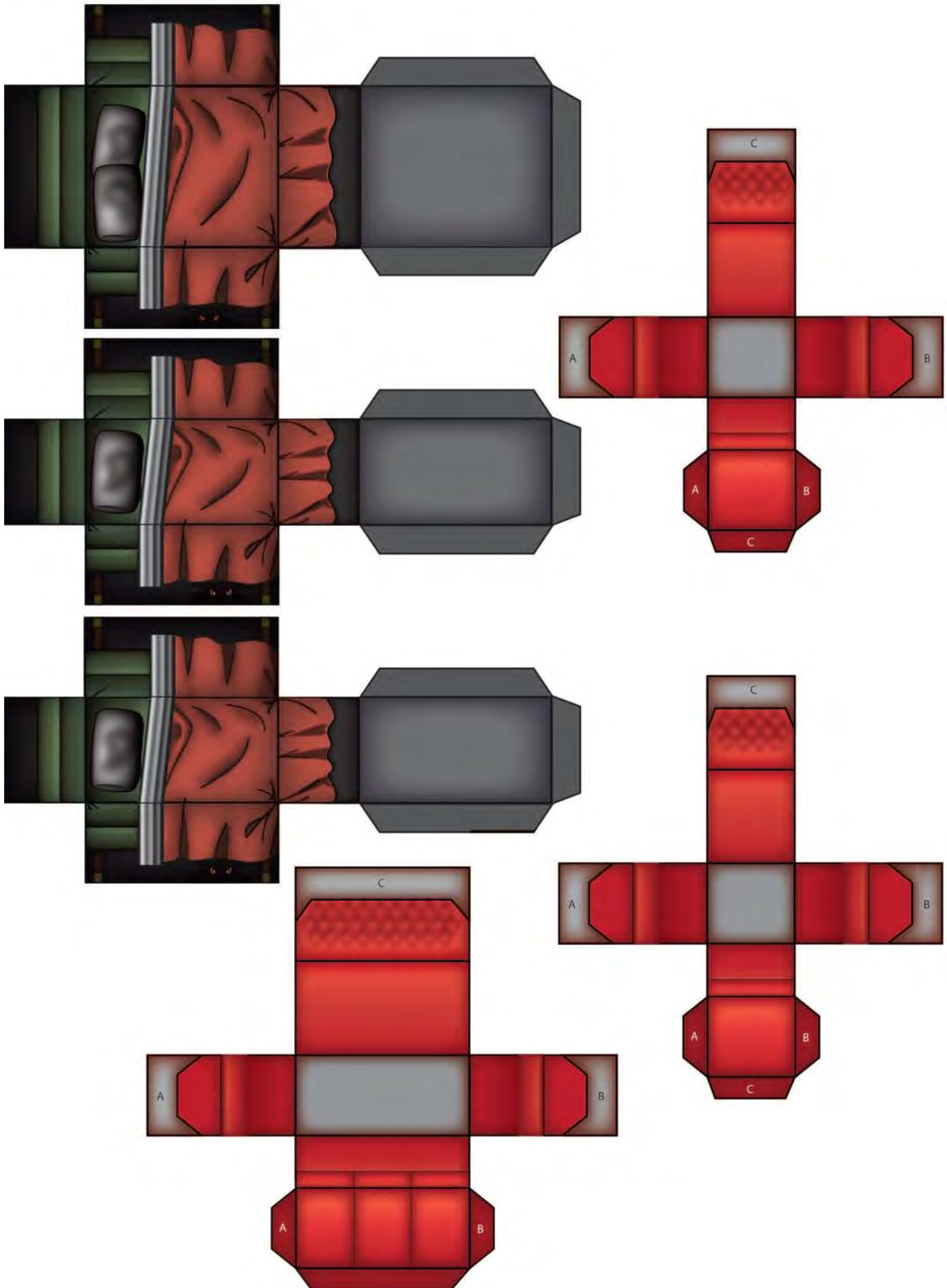

Taller beds

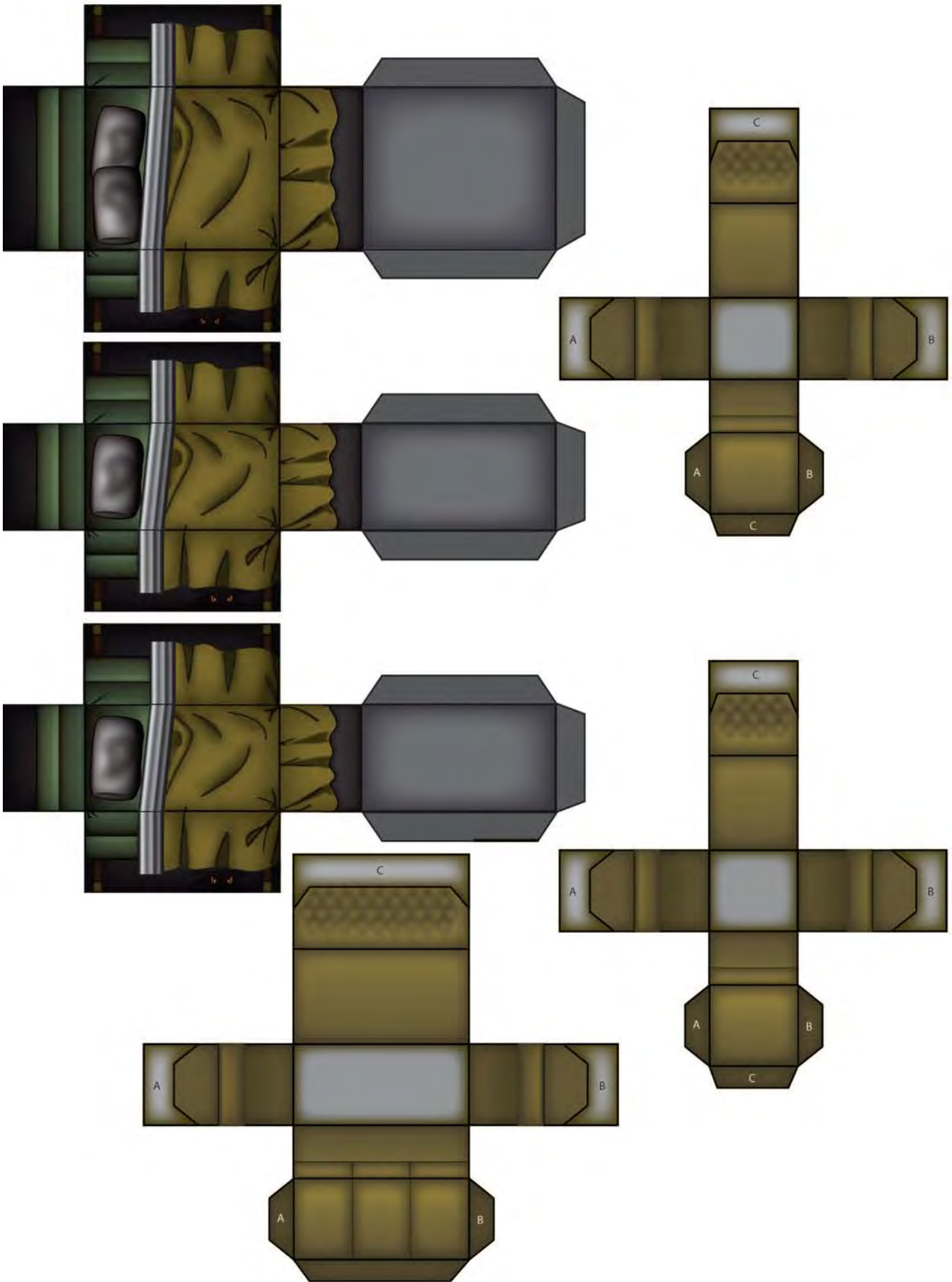

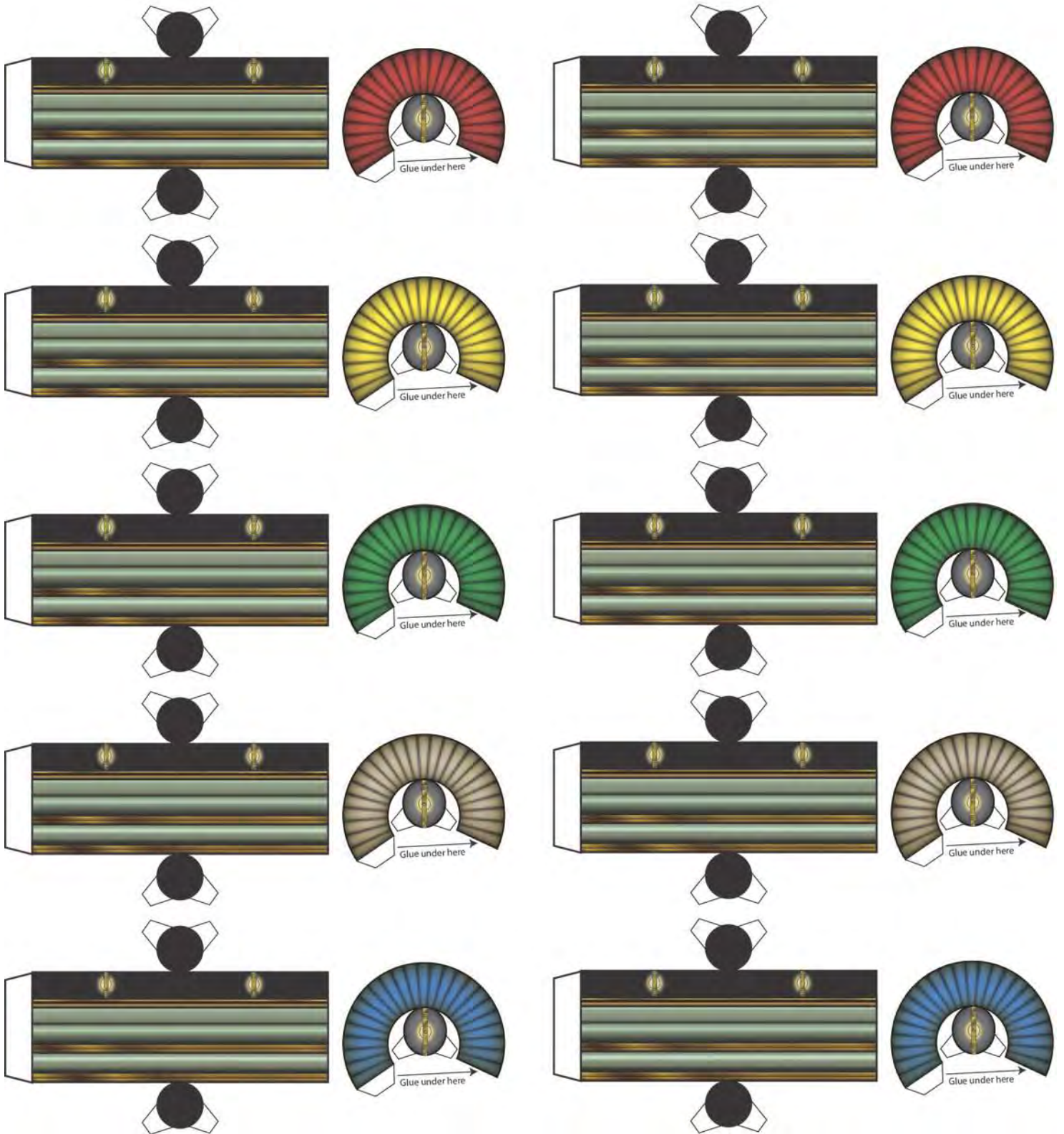

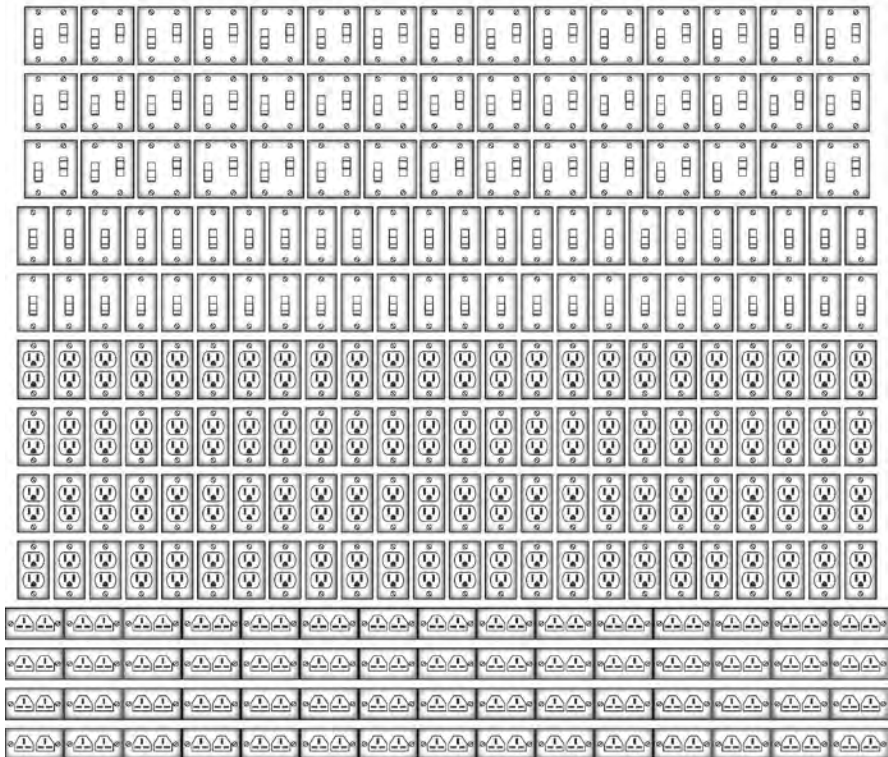
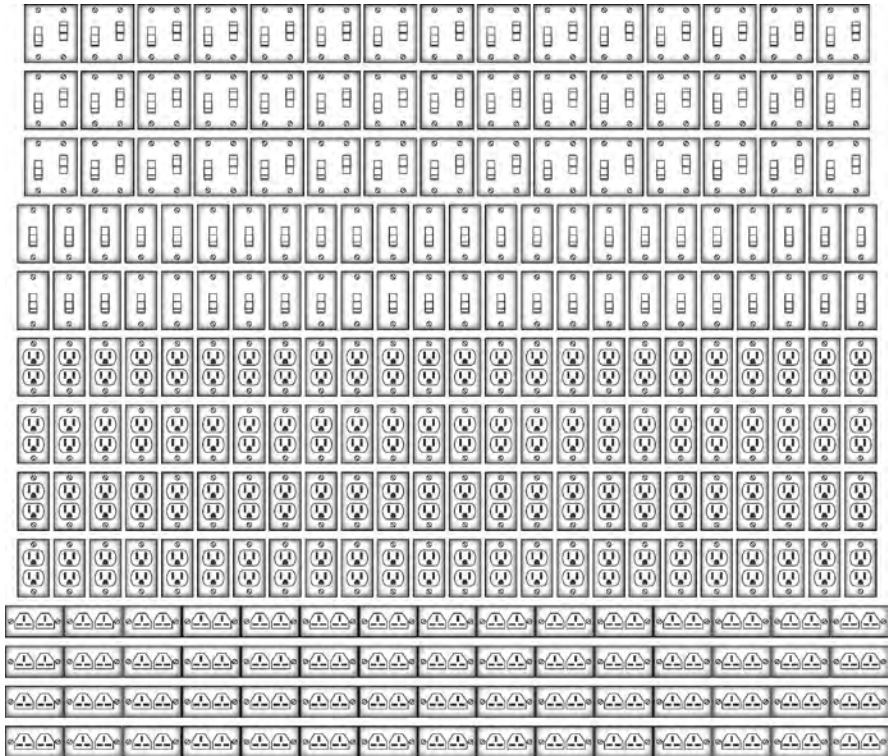

Transparenc-ees

This page is available for those wishing to print on transparency paper, print trim from the Ooopsss on cardstock, and mount front and back to these Transparenc-ees

Cottage and Split-Level sized windows



Farmhouse, and Raised Ranch sized windows

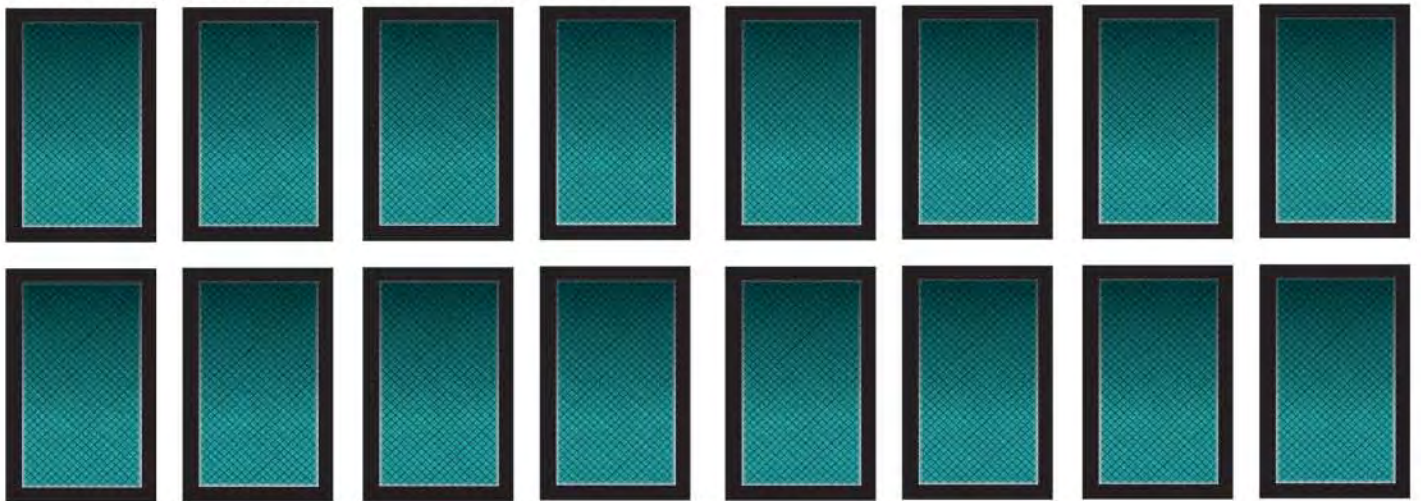

Cape sized windows

