

CLASSIFIED

# HOMES

## Haunted Home: Scott Manor

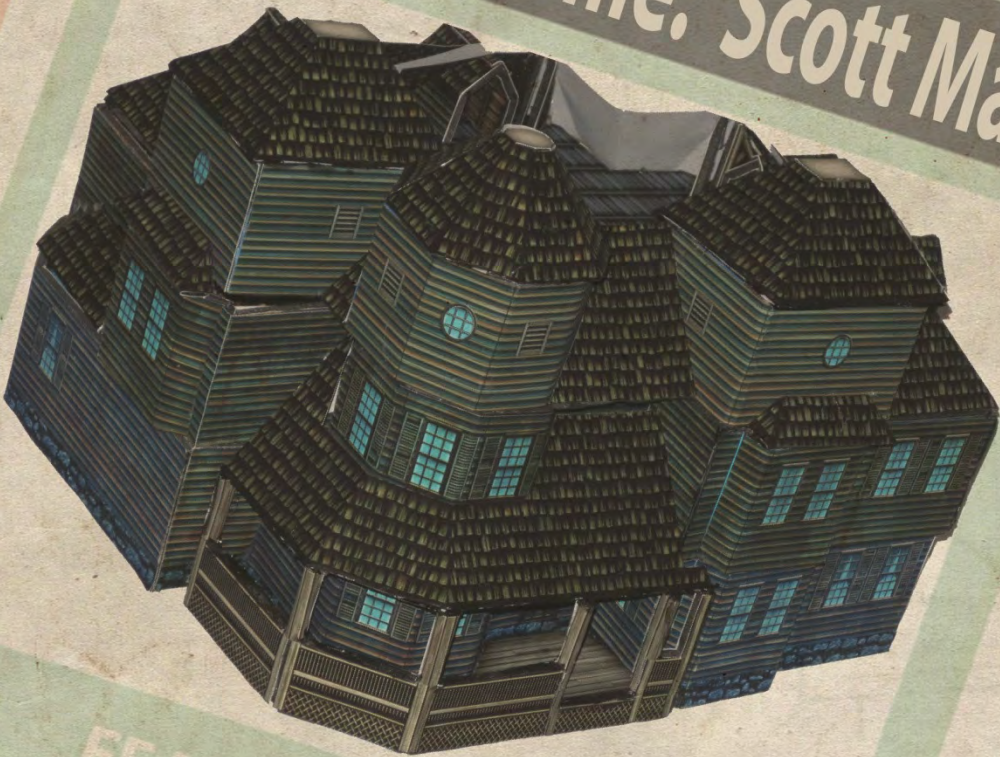

### FEATURED HOME

#### About this listing

A foamcore wargame terrain project suitable for 28-32 mm miniatures. Listed by

# STOELZEL'S STRUCTURES

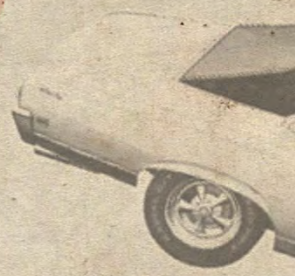

### FEATURED

#### About this listing

Asking price: \$9.00

Lorem ipsum dolor  
ante in

## Classifieds: Scott Manor

S0044

Horror house, the haunted hallows, murder mansion are but a few monikers given to the less than stately Scott Manor. This home, which has been left un-sold, and vacant of living inhabitants for some two decades, was the site of a series of gruesome homicides, or was it tragic accidents.... no one quite remembers at this point anymore. But the stories stuck just the same, and grew, and took on a life all of their own.

Local folklore holds that Scott Manor houses many restless, and long tortured spirits. The last family to own the house were a newlywed couple who had dreamed of leaving the city and of relocating to such a peaceful and tranquil rural environment. Not long after moving in, the man had to travel back to their old city for a couple of days to handle the final closing of their old apartment. When he returned, he found his wife, trembling, naked, and curled into a fetal position, gently rocking back and forth, silently. She never spoke of what had caused such fright. When the husband was called out of town again, he was hesitant, but required by work to go. But when he returned home, he didn't find his wife as he had found her on his last trip, nor did he find her as he left her, he did not find her at all. No signs of struggle, no note, no packed bags or removed belongings, simply gone. The investigating police tried to convince the man that she probably just left to avoid a difficult divorce, but this, nor his friends console were enough assuage the man's pain. Within three months, the man ended his pain.

A creaking and moaning of settling house under duress can be heard on even the stillest of winds, and yet, behind that sound is nothing, silence, no birds, no frogs, no crickets, none of the sounds of life one would expect to hear in the backwoods. Animals that are observed in the area are noticeably startled, and exhibit all sorts of strange behaviors often leading to concerns of rabies, however, no such cases have ever been found locally.

It is of note that cats, dogs, and teenage children seem to go missing from the area with alarming frequency. People who find themselves walking near the edge of the property at night report feeling a tingling on their skin, almost electric, yet cold. Stories tell of the fraternity pledges from the local community college, who just a few years back, had been sent, as a hazing prank, to spend the night alone in the house, and how, even now, have yet to regain their power of speech.

Scott Manor is a three floor build including a ground floor and second floor each with seven rooms, and an attic space with several attached rooms. All interior space in this house is accessible for game play by removing upper floors. As one would expect in an old spooky mansion, this home comes complete with three secret passageways connect rooms in unexpected ways, each of these accessible by hidden sliding doorways. A number of other haunted elements are also included such as our reversible paintings which can change the feeling of a room with a simple slip of cardstock.

Our buildings are designed to be constructed out of 5mm tick foamcore, print, stick, cut and glue. As with all Stoelzel's Structures, this project comes fully furnished and move in ready.



**OPEN  
HOUSE**

**Hidden  
doors**

**Secret  
Passages**

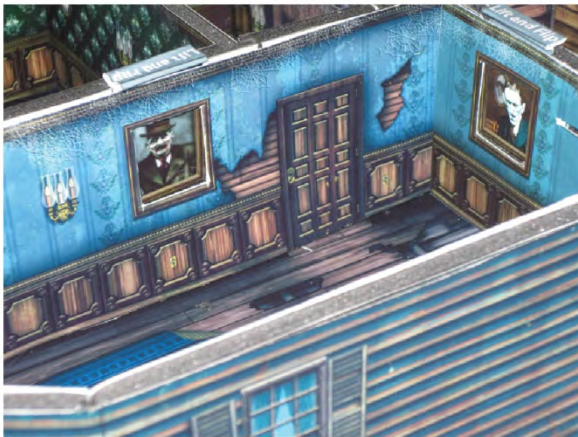
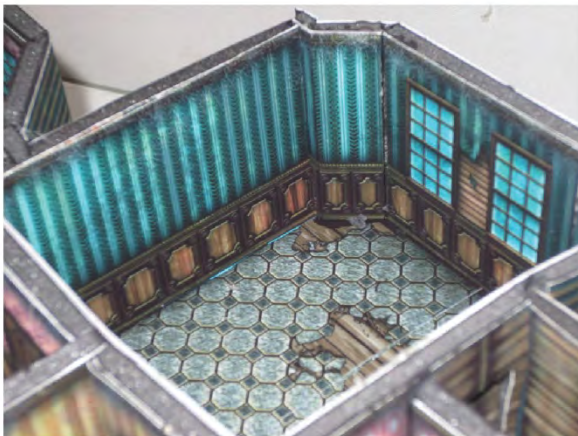
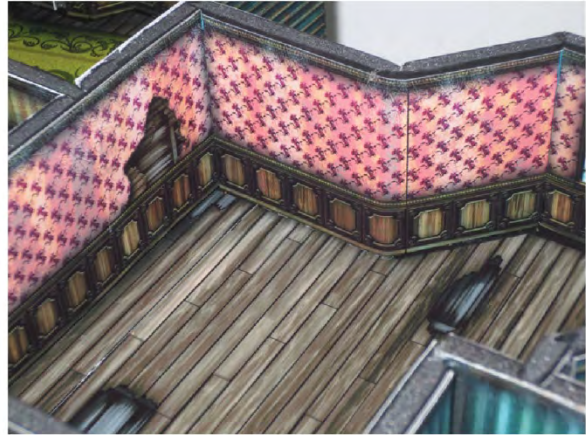

**STOELZEL'S  
STRUCTURES**



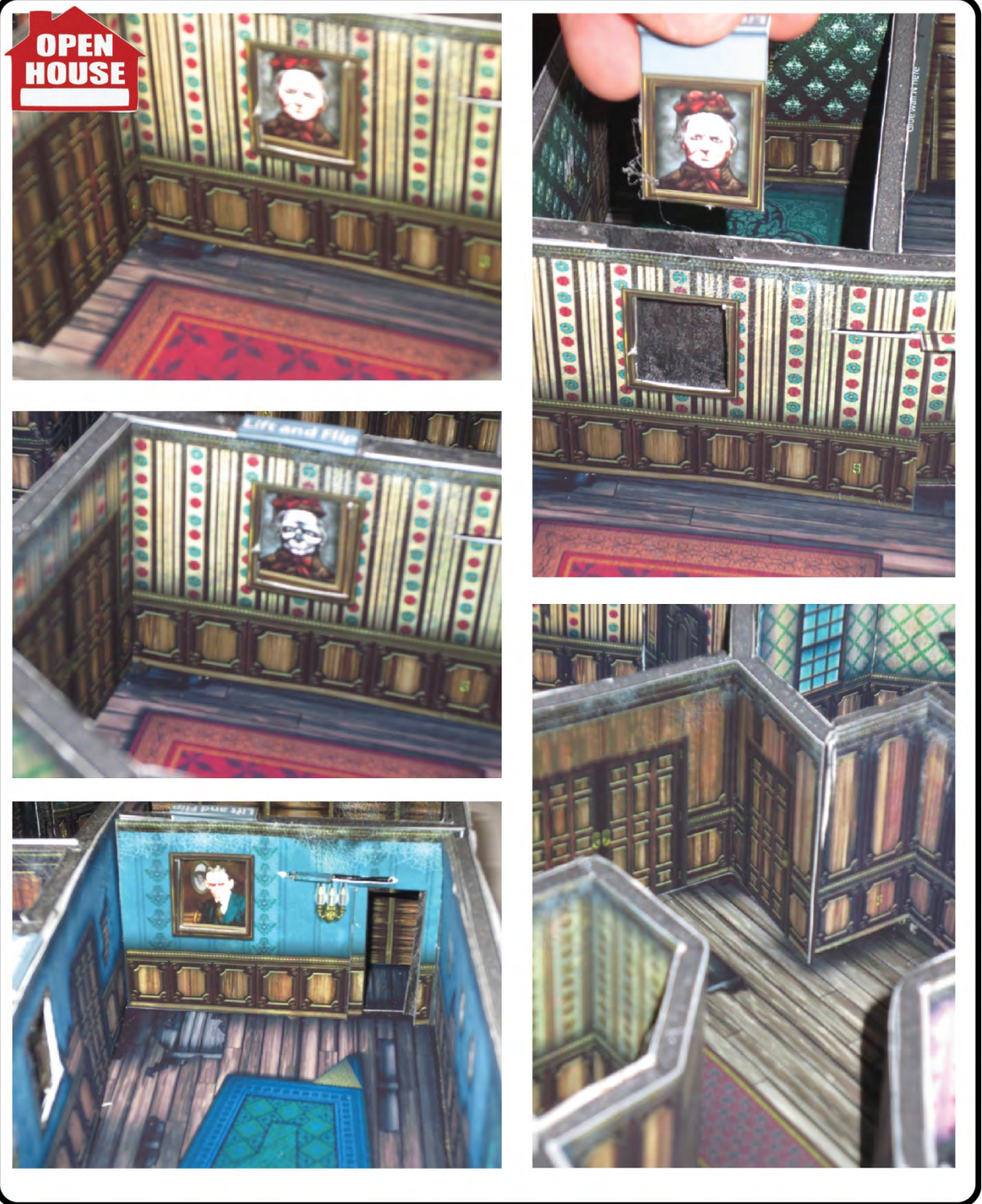

**OPEN  
HOUSE**



**STOELZEL'S  
STRUCTURES**

# Build instructions: Haunted Home 1: Scott Manor

## Legal

All images and text contained within this project are copyright of Carl R. Stoelzel. Permission is granted to print copies of this to build only your own projects. Do not distribute digital copies in whole or in part without the express written permission of the copyright holder.

## Forward

Given a baseline level of difficulty as simple folded cardstock square buildings with at most 6 folds and three glue tabs, than this model is of intermediate difficulty. It was designed to be made primarily of foam core, and often requires the modeler to line up pieces of artwork on both sides. This model will take about 5 hours to. Expect this to take about twice as long if you plan to remove the doors and windows from each wall.

## Materials

- 1 sheet of 5 mm thick foamcore
- Thin Cardstock, a used cereal box should be about enough
- A straight edge (metal rule is preferable)
- A sharp blade (for example an X-acto knife)
- Gluegun and glue sticks
- Cyanoacrylate (Crazy Glue)
- Full sheet label paper (Optional)
- Spray mount and fancy printing paper (Optional)
- A Rabbet cutter (optional)
- A small (~5mm) chiseling blade (optional)
- Black magic marker (optional)

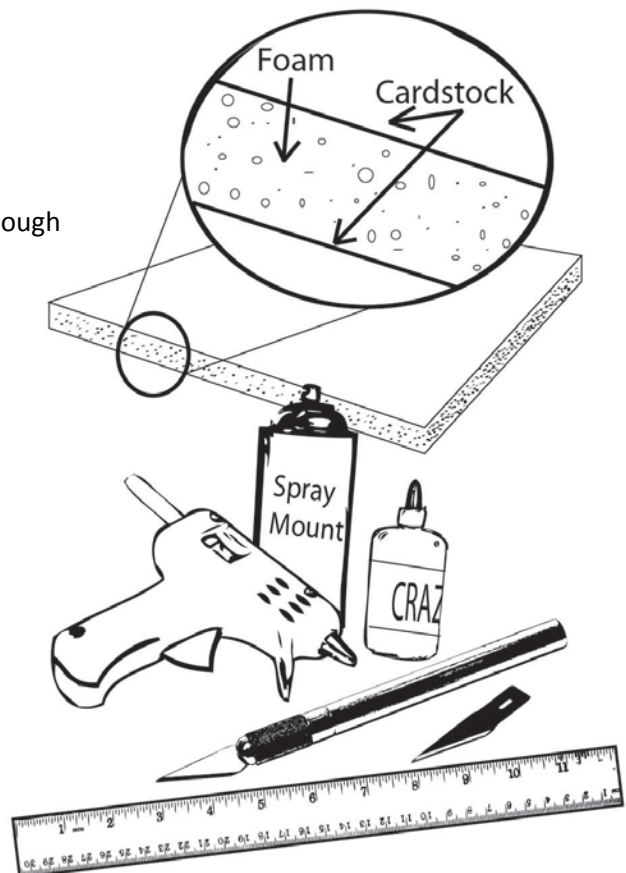

## Techniques

### Mounting

Most pieces of this building have images for the front and back of the foam core support structure. As such, great care should be taken when aligning the pieces. There are two options available to mount the artwork onto the foamcore.

The first option is to print out all the art files onto full sheet label paper. This provides a very simple assembly: peel the back and stick. However, the quality of full sheet labels can be hit or miss, and, in the worst cases, can lead to peeling terrain.

The second option is to use aerosol glue like spray mount or photo mount. Generally these come in two types, a permanent fix and a temporary fix which lets you take the pictures back off later. The temporary fix glue is good if you don't trust your ability to align the two sides, but like the label paper CAN lead to peeling terrain down the road. It should be noted that both of these sprays is that they can be messy and smelly. Please follow all directions on product chosen.

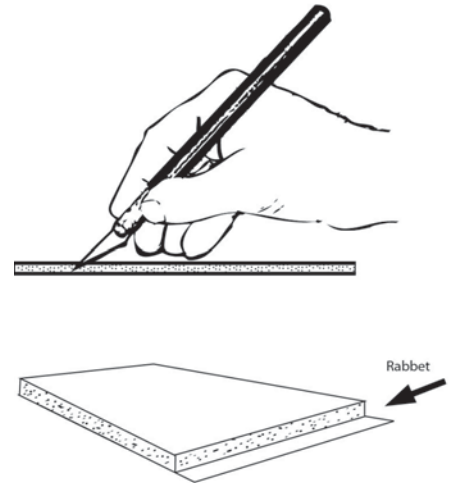

### Rabbeting

Sections which need rabbeting are indicated in the pictures by large blue boxes.



Making a rabbet on one of the pieces of foam, allows us to create a stronger joint when joining ends of two foamcore pieces. This is accomplished by creating a slot or groove to receive the edge of the other foam core piece. This ensures that the seam of the joint is surrounded on three sides. Rabbeting your corners and joints also helps hide exposed edges of foam.

A rabbet joint is made by cutting only partially through a piece of foam core while leaving the opposite side of card stock backing still intact. One must be careful not to cut all the way through, as this could ruin the images on the other side, and also make the piece un-useable.

T intersections where an end piece of foamcore butts up against another perpendicular piece of foamcore can be made stronger and smoother using an interior rabbet joint. These are a bit trickier, but not that difficult to do. An example can be seen here.

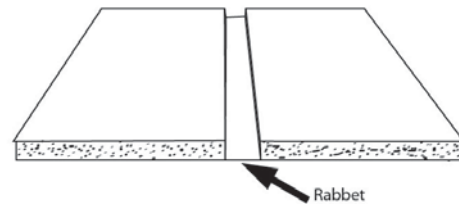

There are a lot of tools available online called foamcore rabbet cutters than can make doing rabbets somewhat easier for the modeler. These rabbet cutters fix the angle and depth of the cutting blade, thus preventing cut through. If you don't have a rabbet you can do these same cuts with a simple blade and a little care.



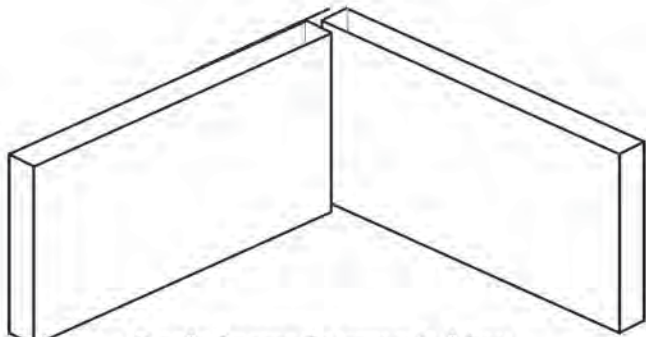

Single layered corner Rabbet

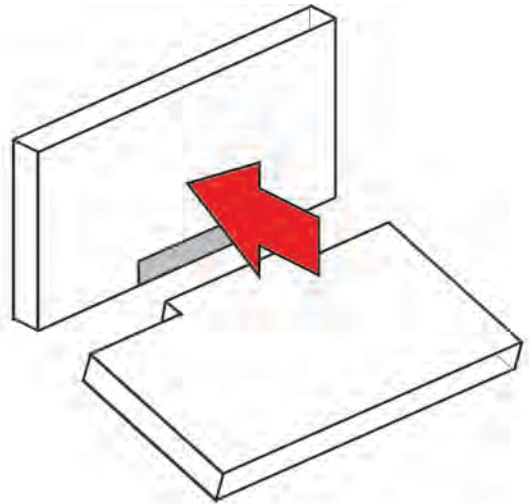

Keyed corner joins

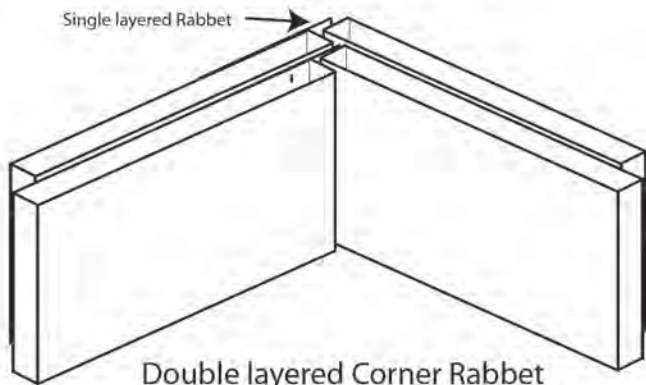

Single layered Rabbet

Double layered Corner Rabbet

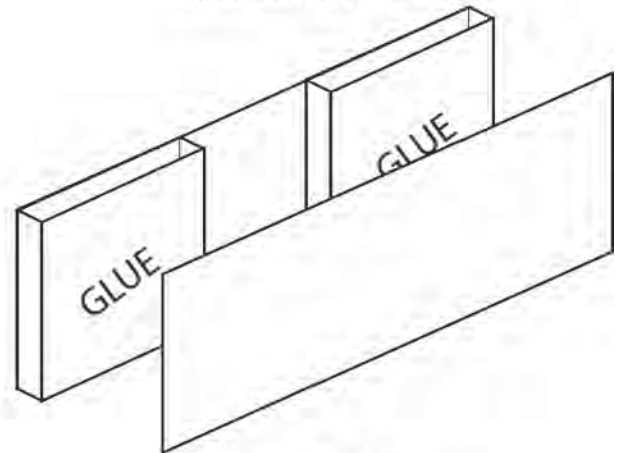

Hidden pockets

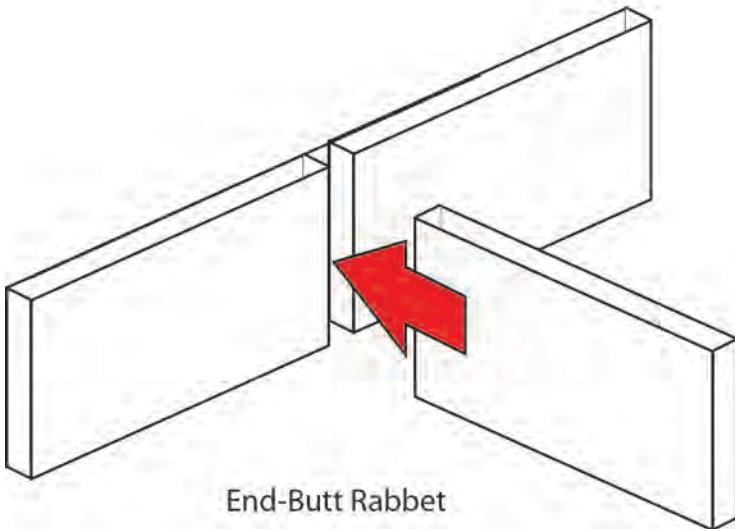

End-Butt Rabbet

## **Build Instructions**

### **List of major parts**

**Labeled walls A to Z.** All the wall section in this build have two sides, commonly referred to as the interior side and the exterior side. When assembling the main walls of this building you will see that the exterior façade of the house is labeled exterior, and the wallpapered/painted walls are labeled interior. This naming convention has been continued to the interior sub-walls solely to help identify images that go together on the same piece of foamcore. Additionally, some walls have “templates”. These are images that are mounted first to the foamcore core, before ANY interior or exterior images are applied, and are used to identify rabbets that need to be made under the wall section and are then later covered up by the painted wall sections.

**Floor sections A-D.** There are three floors in this project, a ground floor, second floor, and the attic. Each floor section is divided into four quarter panels. Each quarter panel has a de-saturated bleeding edge to assist you in stitching the floors together without exposing the foamcore underneath.

**Secret doors and Switch/Flop paintings.** A key feature of the haunted house build are the many hidden sliding doors on both the ground floor and upper level that slide to reveal hidden passages connecting the rooms in other ways. Likewise, family portraits throughout the house can be lifted out of the foamcore walls, rotated 180 degrees and placed back to reveal a new, and perhaps slightly twisted view of the family member.

**Props and furniture:** All Stoelzel’s Structures builds come fully furnished and this is no different. Furniture and props are designed for mounting on cardstock, or to be printed on thicker printer paper and assembled.

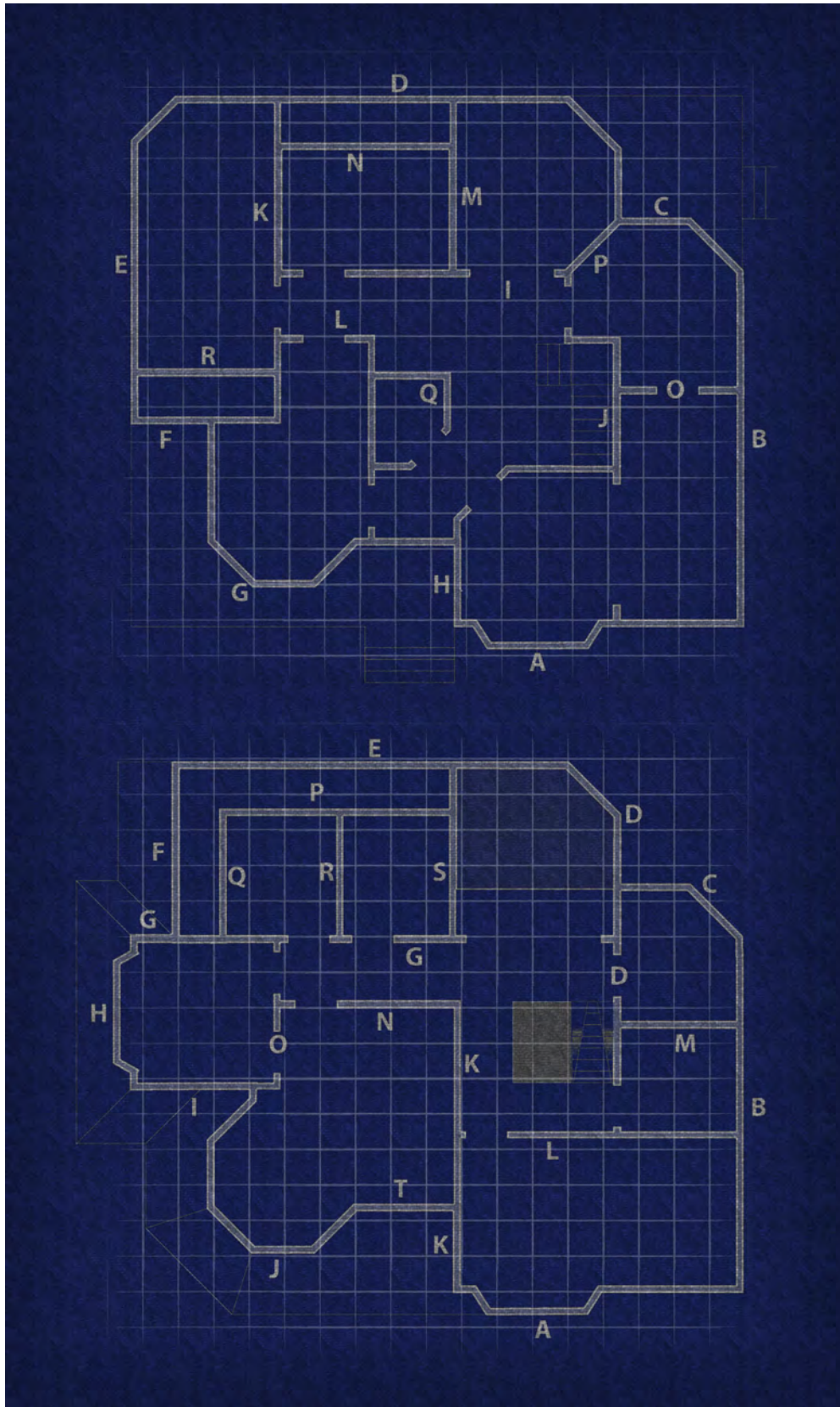

Blue prints for lower (top) and upper (bottom) floors. Labeled wall section positions indicated by letters.

## General Assembly Instructions

**Preface.** There are three floors to this structure, each designed to be accessible by lifting upper floors off the top of the them. I recommend assembling each floor fully before going on to assemble upper floors. Likewise, when you print out the necessary images, be sure to keep you images in separate piles as to not confuse them.

**1.** We are going to begin by mounting the Flooring the building onto five mm foamcore. Each floor is divided into quarter panels and will need to be aligned carefully to avoid exposing the foamcore at the joins. To help in this, a de-saturated bleeding margin is available on two of the four edges of each quarter panel.

Trim the edges of each quarter panel and do a rough test fit on the piece of foamcore you are going to use to make sure it is big enough, and make to keep the floor oriented the same way when you go to do the actual mounting. For the first quarter panel leave both bleeding margings intact and glue down to the board. For the second and third quarter panels you will want to trim off one of the bleed margins that corresponds to edge shared by the already mounted quarter panel. For the fourth quarter panel you will want to remove both bleed margins.

Align the edges carefully and glue all four panels in place. Cut around the perimeter of the floor to remove.

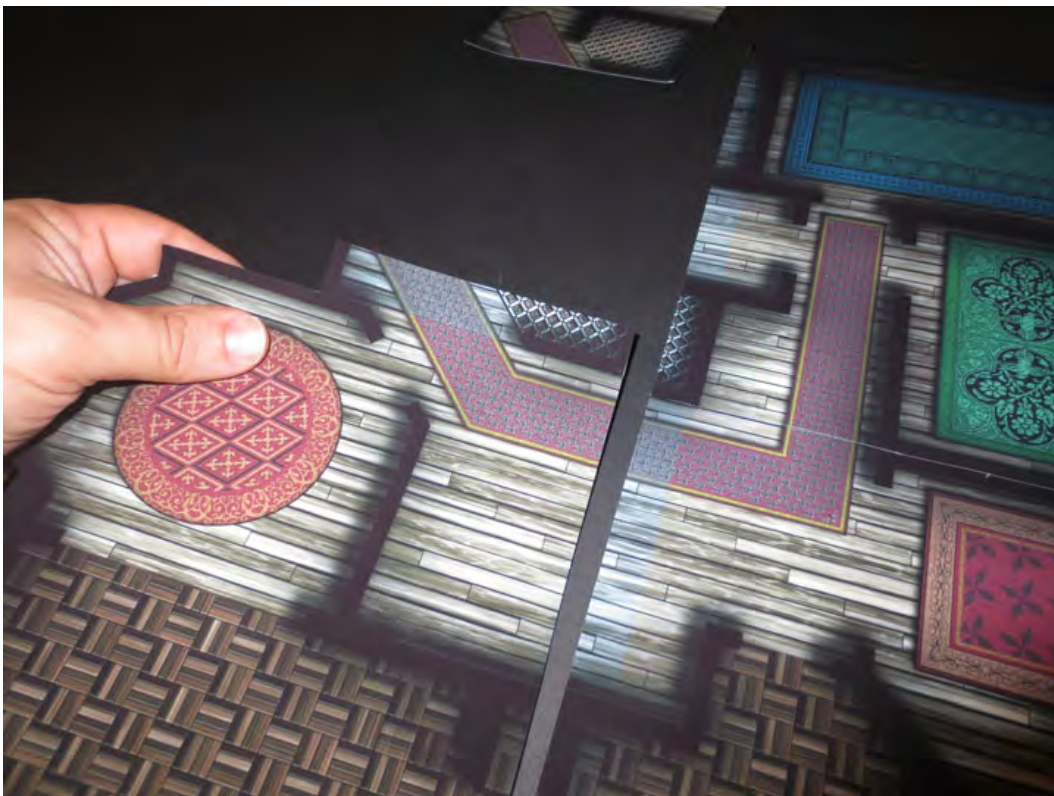

**2.** Next you will continue by mounting the Templates of the building onto five mm foamcore. These are identified on their images as such and are the white triangular sections with one or more blue irregular shapes contained inside. **Note: If you do not want to have sliding doors you will find alternate wall images at the end of this PDF to replace the template images, use those, and skip this step.**

Mount these on five mm thick foamcore, and cut along the perimeters to remove. I recommend labeling the template in pencil or pen to keep track of which is which.

The light blue irregular shapes indicate areas that need to be rabbeted.

Cut along the side and top of the blue box without cutting all the way through. Using a chiseling blade or very carefully using a regular blade start to cut the foam block from the wall, working from the exposed bottom to the top. Gently pull away the foam as you work up. ***[Builders tip: I recently found that a small flat screwdriver about five mm wide can serve as a great chisel in a pinch].***

Locate the print outs for the wall sections identified as belonging to the template pieces. Each of these wall sections has a front and back section. You will first want to identify which side goes onto the surface of the template foamcore piece you just rabbeted. This will be the side in which the doors align with the rabbets, and have a horizontal slot running just above them (for the slide mechanism).

Having identified this piece, cut out the horizontal slide, and remove any white shapes you find (for doorways or paintings). Take the door you assembled and make sure the tab is folded 90 degrees. Place the door into the rabbet, and place the wall section on top of the foam/door so that the tab projects through the slot. Glue the image down onto the foam.

You may glue the curl onto the tab to ensure it won't accidentally fall back through the slot.

Flip the piece over and mount the reverse side image on other side of the foam. Take care to align them front to back.

**3.** Next you will continue by mounting the remaining walls of the building onto five mm foamcore. Each of these wall sections has an image for the front and back of the foamcore, and you will need to match these, and align them carefully. The easiest way I find to align them is to mount the front side, cut it out, trim any and all doors if I am going to do these, and only then proceed to mount the backside image. This will allow you to use each corner as a reference point.

**IF** you wish to remove the windows and doors, now is the time to do it (*while you can still lay them flat on a cutting surface*). Be sure to leave the window/door frames intact which cutting along the item.

It is now time to make all the necessary rabbets on your wall sections. All rabbets are indicated by a light blue box. Cut along the side and top of the blue box without cutting all the way through. Using a chiseling blade or very carefully using a regular blade start to cut the foam block from the wall, working from the exposed bottom to the top. Gently pull away the foam as you work up. ***[Builders tip: I recently found that a small flat screwdriver about five mm wide can serve as a great chisel in a pinch].***

**4.** With all the basic wall pieces mounted and rabbeted, it is now time to assemble the building.

Preface: You are going to begin by assembling the outer perimeter walls and gluing them one by one to the floor. The horizontal g found near the bottom of the outer wall sections is there to join to the floor.

On the ground floor, this rabbet is a ½ inch up off the ground and the floor will need to be pushed into the rabbet tightly, gently flexing the wall can widen the rabbet slightly to help insert the floor. On the upper floor, the rabbet runs along the bottom and is simply a matter of bringing the two pieces together at 90 degrees.

### **First Floor walkthrough**

4A) Start with Wall section A. There are two rabbets on the exterior side that are near the windows, and two more on the interior sides near the windows, these are corner bends. You can see the end shape of the window box area in the floor plans. Pre-fold along the vertical black lines on the opposite side in relation to the rabbets. Put some hot glue into the rabbets and hold the wall into shape while it cools. Test fit the wall against the floor and glue in place.

4B) Test fit wall section B against the floor, and corner rabbet join with piece A. Glue in place.

4C) Wall section C has two corner bends to make as you did in step 4A. Additionally, the middle bend does not need to be glued and is just there to open up the wall, leaving a 90 degree square rabbet, exposed on two sides. Test against the floor, and against piece B, glue in place.

4D) Test fit wall section D against the floor, and corner rabbet join with piece C. Glue in place.

4E) Piece E has a corner bend to make. Glue in shape. Once cool, test fit against floor and piece D, glue in place.

4F) Test fit wall section F against the floor, and corner rabbet join with piece E. Make sure the shorter section of wall slips over the edge of the floor. Glue in place.

4G) Piece G has a series of corner bends to make. Refer to the blue print to get a feel for the shape. Once cool, test fit wall section G against the floor, and corner rabbet join with piece F. Glue in place.

4H) Test fit wall section H against the floor, and corner rabbet join with piece G. Make sure the shorter section of wall slips over the edge of the floor. Glue in place.

4I) Slide piece K into the rabbet in wall D, and make sure to join to the corner with piece F. Check the color of the walls to make sure it is oriented correctly. Glue in place.

4J) Slide piece R into the rabbets on pieces K and E. Glue in place.

4K) Piece L has a corner bend, bend 90 degrees and glue in shape. Slip into the rabbets on piece K and Piece G. Glue in place.

4L) Piece Q has several corner bends to curve around. Glue in shape, once cool, slip into the rabbets on piece L and glue in place.

4M) Piece J has a corner bend, glue in shape. Slip into the rabbet on piece A, make sure piece H slips into the corresponding rabbet. Glue in place.

4N) Piece I has a corner bend. Open the shape to expose the rabbet. Slip into the rabbet on piece K and join with the corner rabbet to piece J. Glue in place.

4O) Piece P, slip into the on piece I and piece C. Glue in place.

4P) Slide piece O into the rabbets on piece J and piece B. Glue in place.

4Q) Slide piece M into the rabbets on piece I and piece D, glue in place

4R) Slide piece N next to the black boxes on piece M and piece K, use the interior corner wrappers marked N-M and N-K to attached to these walls.

...move onto the second floor elements or additional decorative elements.

### **Second Floor walkthrough**

4A) Start with Wall section A. There are two rabbets on the exterior side that are near the windows, and two more on the interior sides near the windows, these are corner bends. You can see the end shape of the window box area in the floor plans. Pre-fold along the vertical black lines on the opposite side in relation to the rabbets. Put some hot glue into the rabbets and hold the wall into shape while it cools. Test fit the wall against the floor and glue in place.

4B) Test fit wall section B against the floor, and corner rabbet join with piece A. Glue in place.

4C) Wall section C has a corner bends to make as you did in step 4A. Test against the floor, and against piece B, glue in place.

4D) Wall section D has a corner bends to make as you did in step 4A. Test fit wall section D against the floor, and pocket rabbet join with piece C. Glue in place.

4E) Test fit piece E against floor and piece D, glue in place.

4F) Test fit wall section F against the floor, and corner rabbet join with piece E. Glue in place.

4G) Test fit wall section G against the floor, and pocket rabbet join with piece F. Make sure the wall height transition slips over the edge of the floor. Glue in place.

4H) Piece H has a series of corner bends to make. Refer to the blue print to get a feel for the shape. Test fit wall section H against the floor, and corner rabbet join with piece G. Make sure the shorter section of wall slips over the edge of the floor. Glue in place.

4I) Test fit wall section I against the floor and make sure the wall height transition slips over the edge of the floor. Glue in place.

4J) Piece J has a series of corner bends to make. Refer to the blue print to get a feel for the shape. Test fit wall section H against the floor, and pocket rabbet join with piece I. Glue in place.

4K) Test fit piece T along the floor, and corner rabbet join with piece J

4L) Test fit wall section K against the floor, and pocket rabbet join with piece T, and corner rabbet with piece A. Make sure the shorter section of wall slips over the edge of the floor. Glue in place.

...move onto the attic or additional elements.

### **Attic walkthrough**

4A) Start with three room sections. Locate the corner bends on the interior side and put some hot glue into the rabbets. Hold in shape until dry and glue onto the attic floor where indicated in the blue prints.

4B) Take the attic windows. Locate the corner bends on the interior side and put some hot glue into the rabbets. Hold in shape until dry. Fold the roof sides inward, and fold the fold roof flap over the corresponding roof side so that it covers the apex. Glue the tab down, and glue the roof sides to the walls. Glue the windows to the attic floor where indicated in the blue prints.

4C) Take the roof support pieces, and glue these on the attic floor where indicated.

4D) Take the roof shingled panels and glue these onto the roof support pieces. Use the tabs to attach roof panels to one another.

....will you start working on those additional elements already?

## **5.** Additional elements.

Assemble the porch and small roof elements that will be attached to the exterior.

### **5A) Stair assembly.**

Stairs consist of two parts, the steps, and the wrapper (sides). Mount the wrapper onto cardstock, or print out on heavy paper, trim, and set aside.

Mount the steps onto 5 mm thick foamcore. Cut along the perimeter to remove. Locate which end of each step has the printed stair raiser on it. Flip the step over, and rabbet the edge 10mm back. Flip the piece back over, and locate the black line separating the riser from the runner. Fold along this 90 degrees so that the runner covers the exposed edge of foam, and goes past it slightly. Tuck the excess under the stair completely. Once the shape is pre-folded, glue the riser down.

The stairs go from top to bottom in increasing size. Take the top step and glue it onto the next bigger step onto the grey area so that the lower step protrudes outward. Continue doing so until the bottom step.

Locate the stair rails, and fold 180 degrees between the mirror images so that they come together.

Take the wrapper and fold along the vertical black lines to form the contour of the stairs. Glue around the stair steps to cover the sides.





**5B) The Porch**

The porch has three main pieces: The wall, the floor, and the roof section. Mount the first two on 5 mm thick foamcore and the latter on cardstock. Cut around the perimeter to remove. Rabbet the blue areas on the interior of the wall section.

There are several rabbeted corner bends. Put a little hot glue into the vertical rabbets and hold into shape while it cools.

Take the floor and slip it into the horizontal rabbet. Glue in place.

The porch roof comes into two pieces which need to be stitched together at the front lower corner. You will see tabs on both pieces, that should fit together like a zipper. Take the roof section and fold the sides downward, and the bottom of it upward to enclosed the irregular shape. Use the tabs to firmly attach sides to one another, again, these should come together like a zipper.

Glue roof onto the porch section, and places next to front of ground floor. Glue if desired.

## Furniture Build Instructions

Print the sheets of room fixtures on heavy bond paper. Some of the flat pieces such as paintings, window frames, door frames etc you might like to mount onto thick card. Most the furniture will be too difficult to fold on thick card.

Cut out all your furniture and decorations. Draw around the edges of your cuts with black marker.

Fold along thick black lines. Use tabs to glue opposing sides of a piece or to glue a piece to the house.

**A note on folds:** There are two main types of folds you will need to make: Convex and Concave. Convex folds refer to any fold (90 or 180 degrees) where the images remain on the outside of the fold surface. Or in other words, the two sides of the fold are pushed away from each other. Concave folds are done in the opposite direction, with the images being brought toward each other.

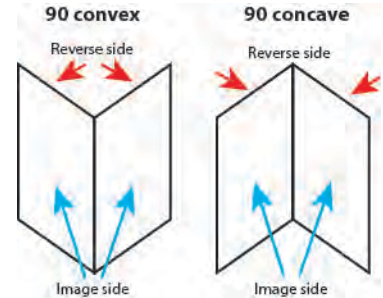

### **Tables, Dressers, Toy boxes, etc.**

Tables are a simple cube once assembled. Fold along the four black lines that separate the top of the table (found in the middle) from the four sides. Then fold the four white tabs ninety degrees so that they tuck under the sides of the table. Put a drop of glue on the white tabs to permanently fix in place.

### **Sink**

Sinks are a simple cube once assembled. Fold along the four black lines that separate the (found in the middle) from the four sides. Then fold the four white tabs ninety degrees so that they tuck under the sides of the sink. Put a drop of glue on the white tabs to permanently fix in place. Glue on to the wall where desired.

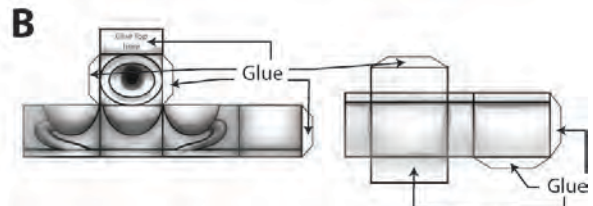
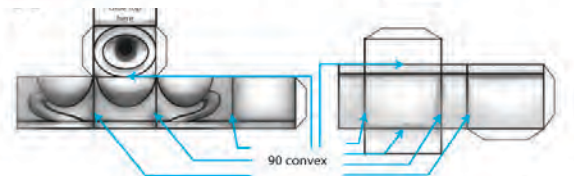
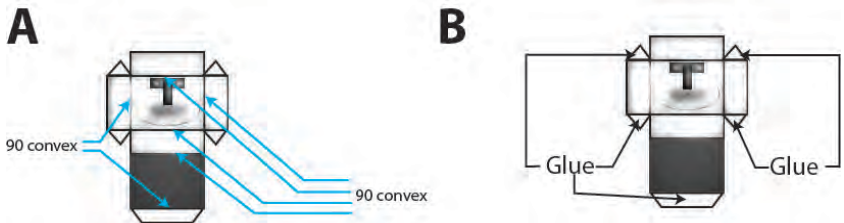

### **Toilets**

Toilets come into two pieces, a bottom and a top, but both pieces are a simple cube once assembled. Fold along the four black lines that separate the front (found in the middle) from the sides, top and bottom. Then fold the four white tabs ninety degrees so that they tuck under the sides of the table. Put a drop of glue on the white tabs to permanently fix in place. Glue the toilet top on top of the toilet bottom.

**Television/Computer monitor.**

The TV is not that different from the other simple cubes you've seen in this furniture set. The only departure is the back side, which is designed to stick out. You will see a small rectangle in the middle of the back, this part is going to be parallel with the front of the unit. The four sides which are adjacent will fall at roughly 45 degree angles, and come together at their seams. Use the tabs to glue together.

**Piano.**

The Piano is also a lot simpler than it might appear. It is, at heart, a simple cube. The only piece that you need to watch for is the keyboard, which will, when complete, face upward.

**Couch and Soft Chairs.**

The grey square in the middle of the piece is actually the bottom of the chair/couch, and will face the ground. The front, back and sides are adjacent and will fold upward, and face outward. The adjacent face going further out will be folded inward, and in the case of the back and sides, will be folded 180 degrees.

**Lamps**

The lamps consist of two parts: the base and the shade. The base is assembled by rolling the long cylinder and gluing it closed with the tab. The two circles fold over to cover the ends and glue shut using the tabs. The light bulb points up. The shade is assembled by rolling the long curve into a cone shape and glue the tab under the opposite end. Close the shade by folding the circle over and gluing the tabs under the shade. Glue the shade on top of the base.

**Benches**

Benches are very similar to tables in that they are largely just a cube. The difference is in the high back which is a doubled over section of card. Fold the front and back side of the back 180 degrees and glue together. Then fold the arms and seat around as if making a cube.

# Ground Floor

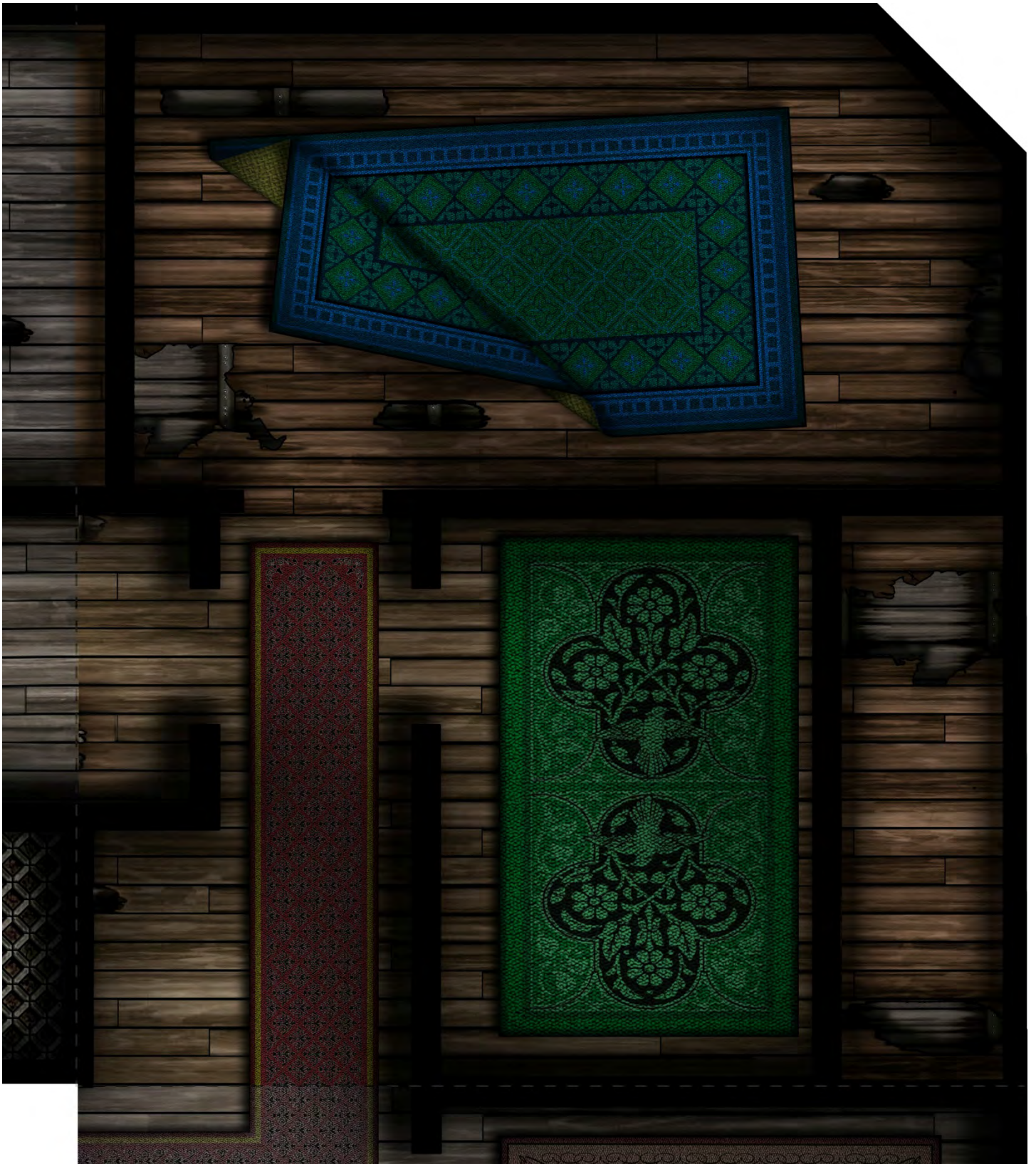



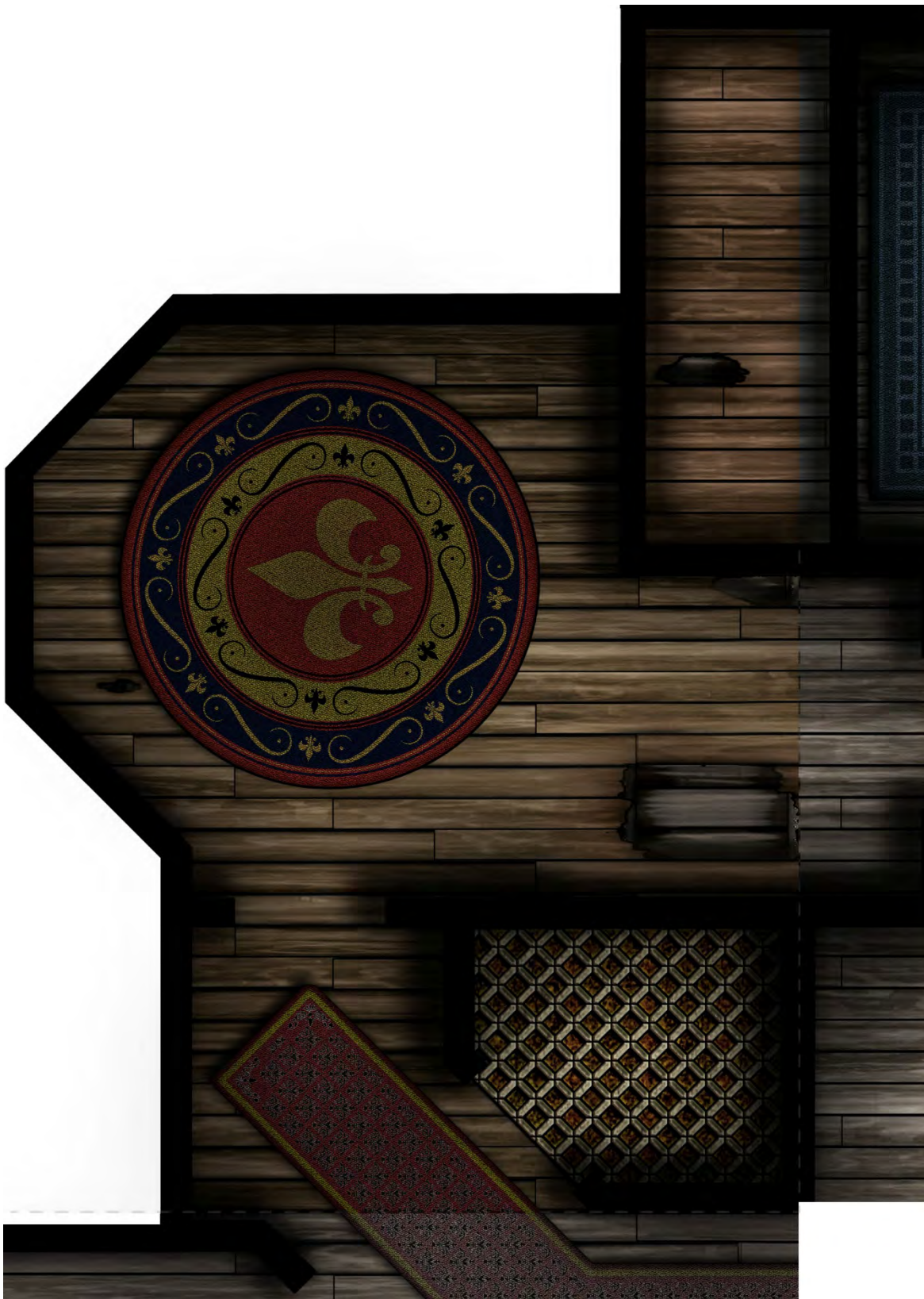

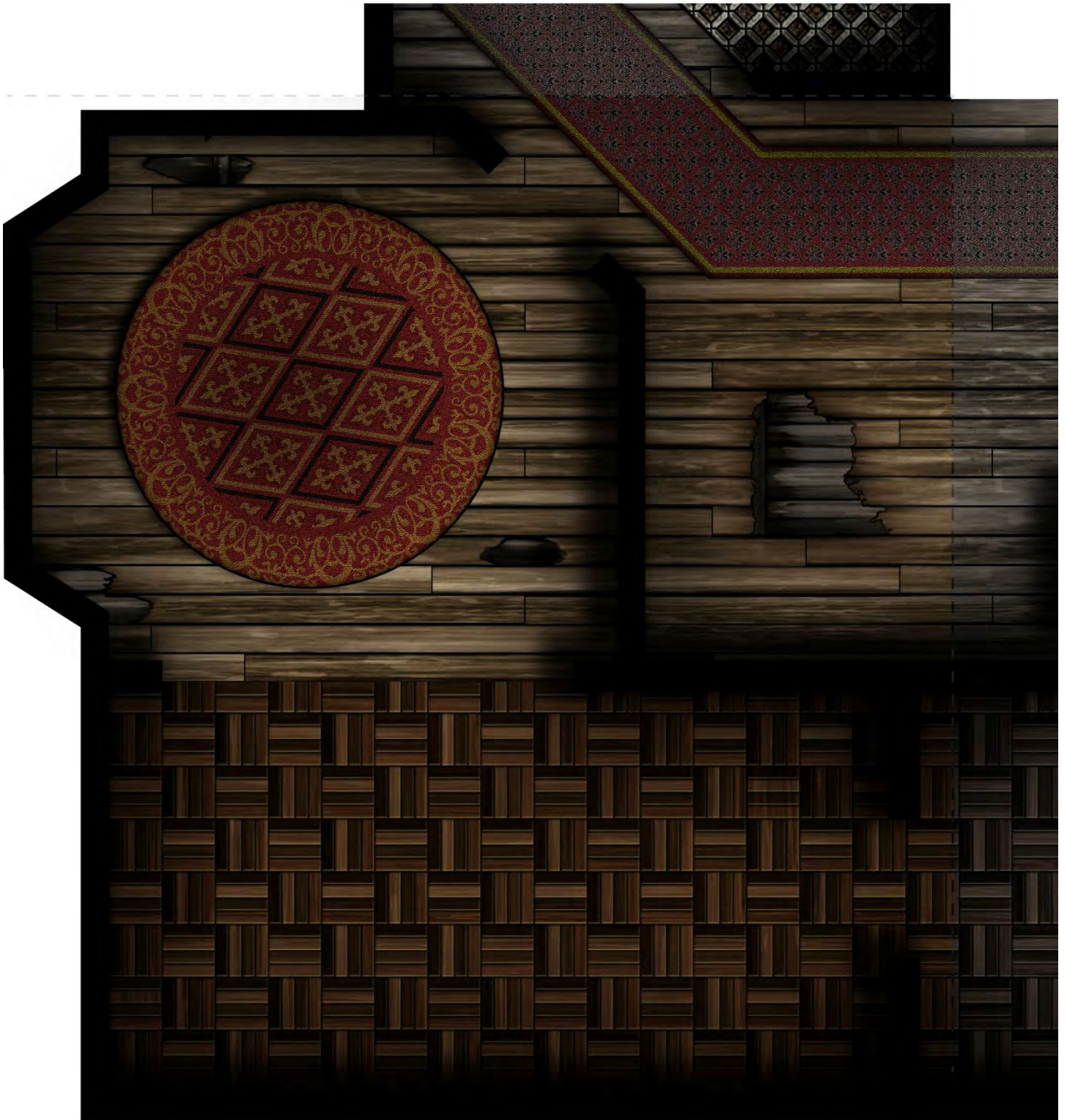



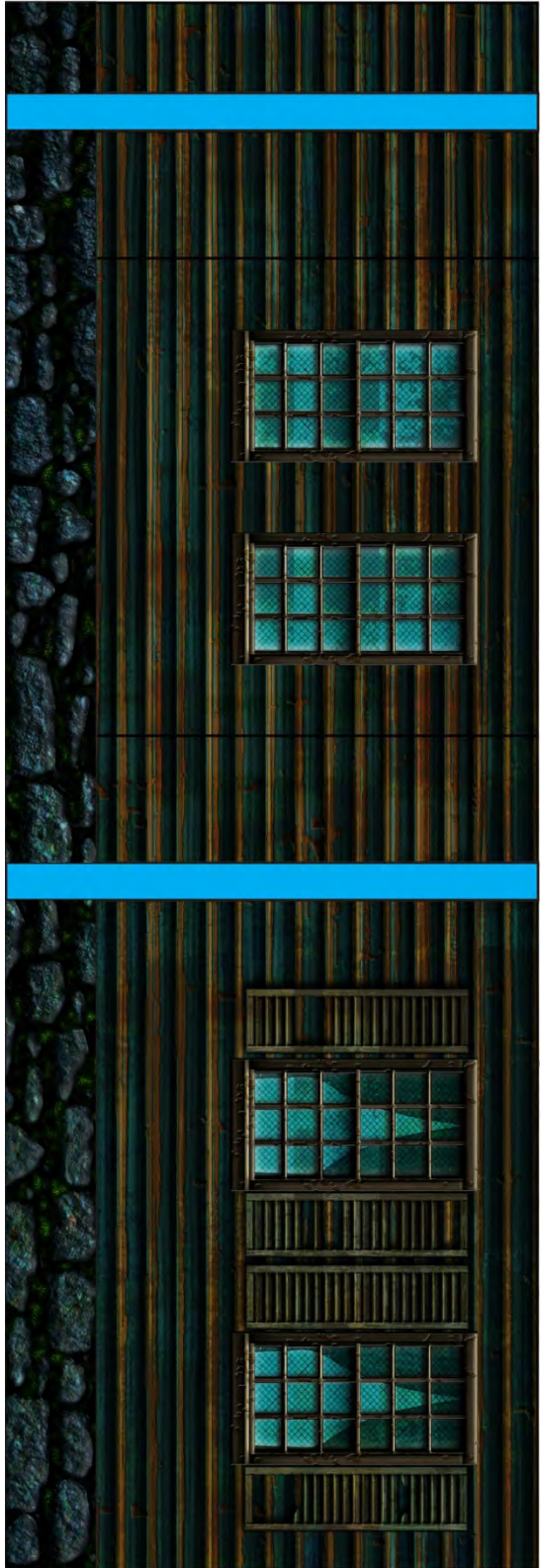

Exterior



A Interior

# B Interior



# Exterior





Exterior

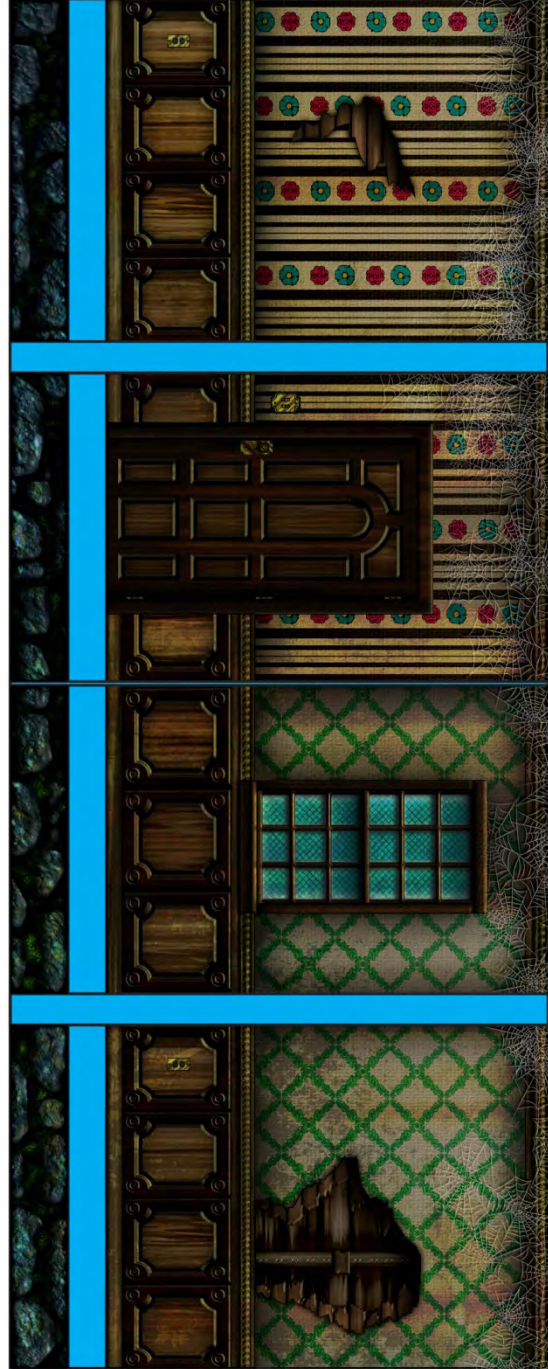

Interior

**D**  
Interior

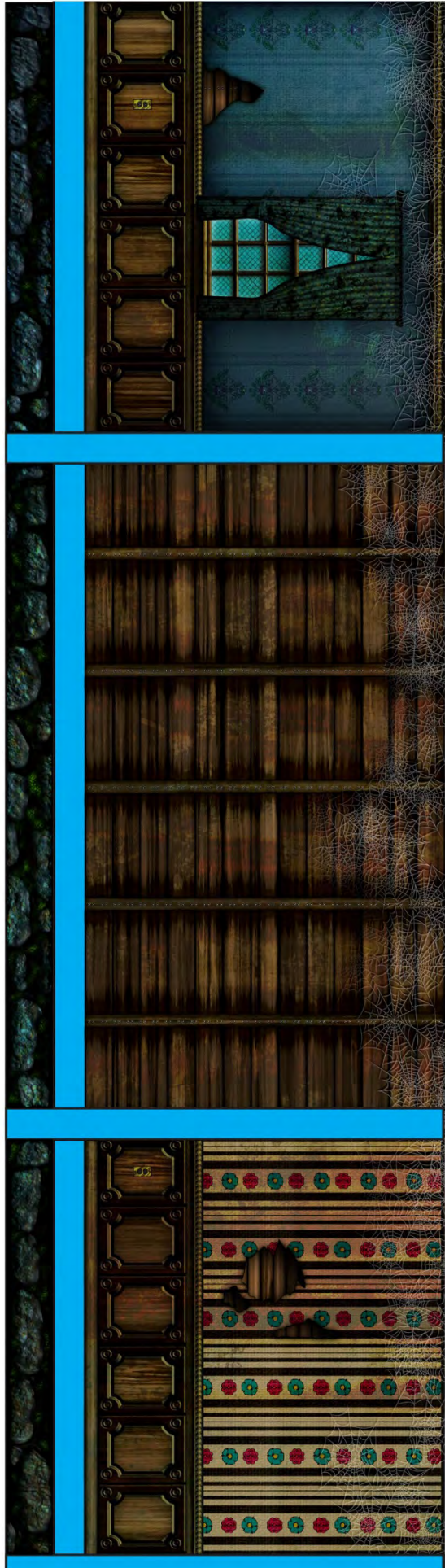

**E**  
Exterior





Exterior



Interior

# F Interior

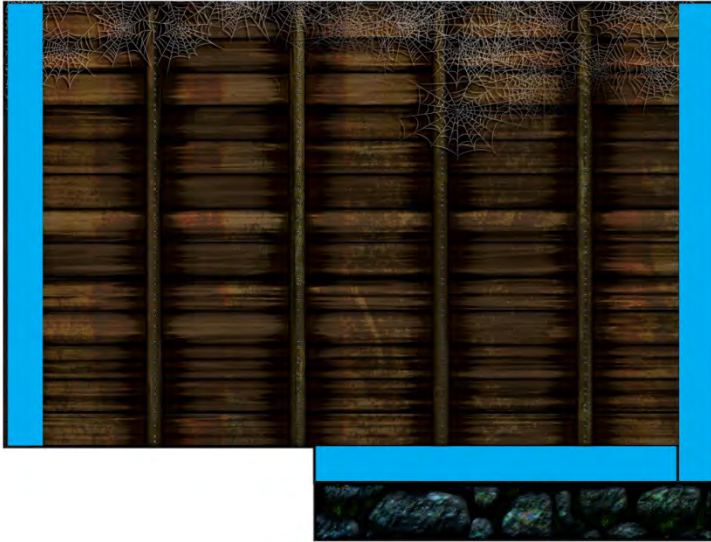

Interior corner wrappers

## N-K N-K



# Exterior



## N-M N-M





Exterior



Interior



**Exterior**



**H Interior**



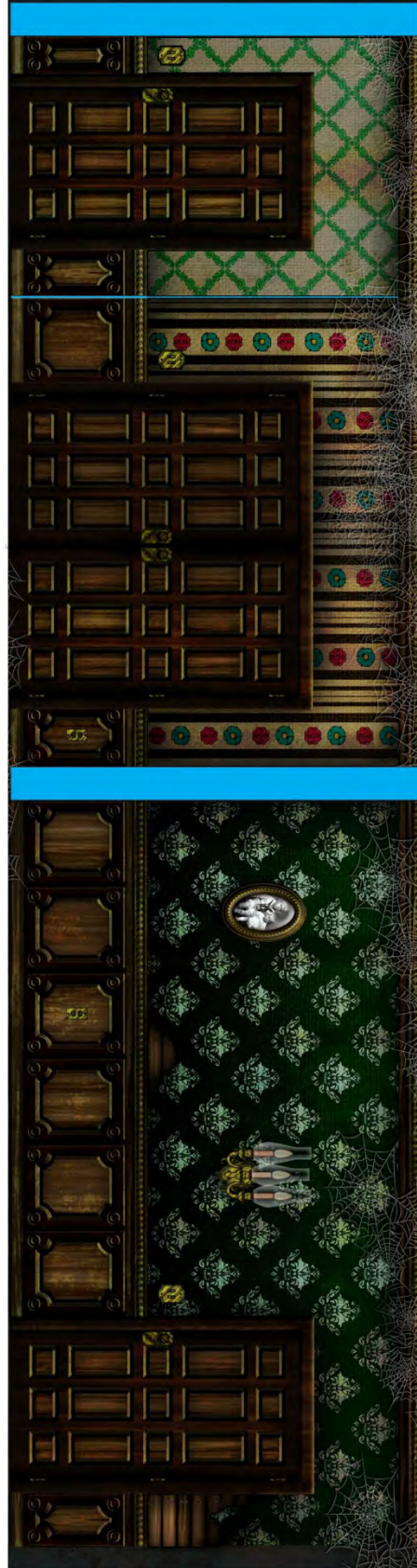

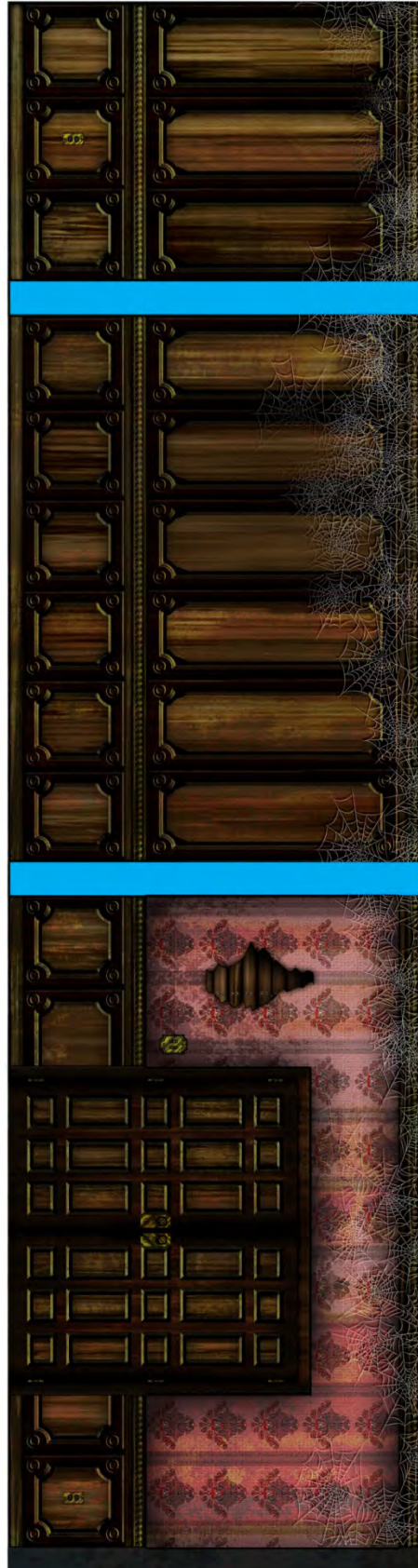

J

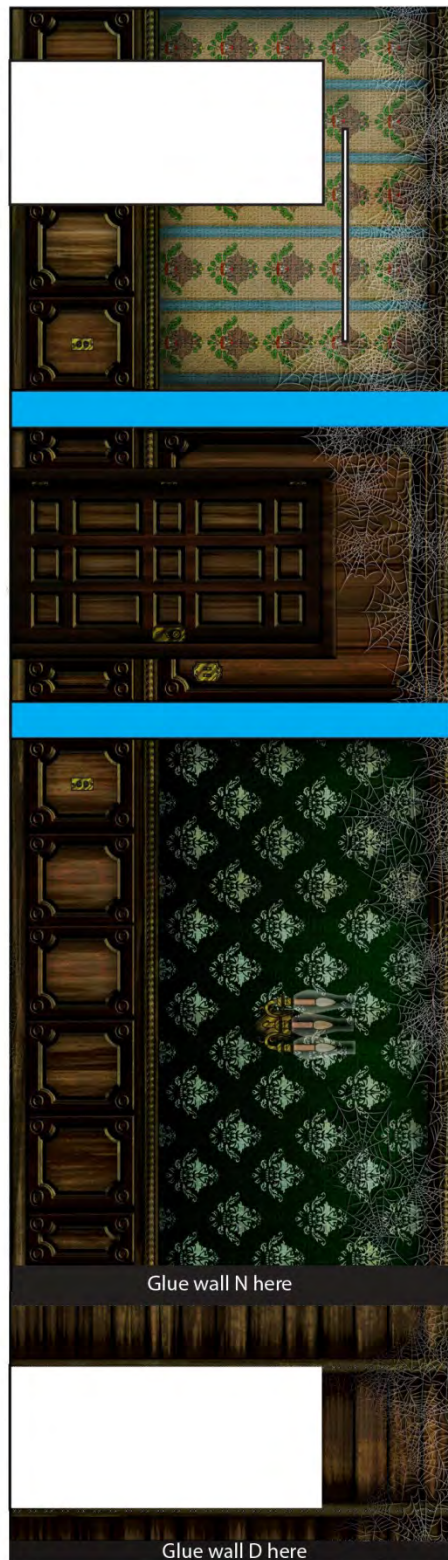

**K**  
Exterior

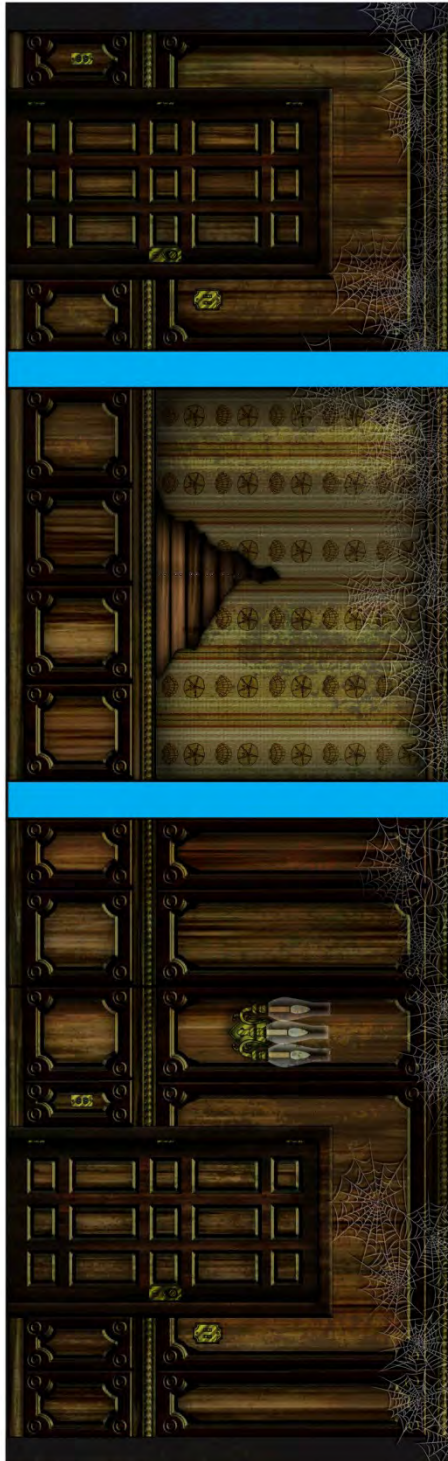

M

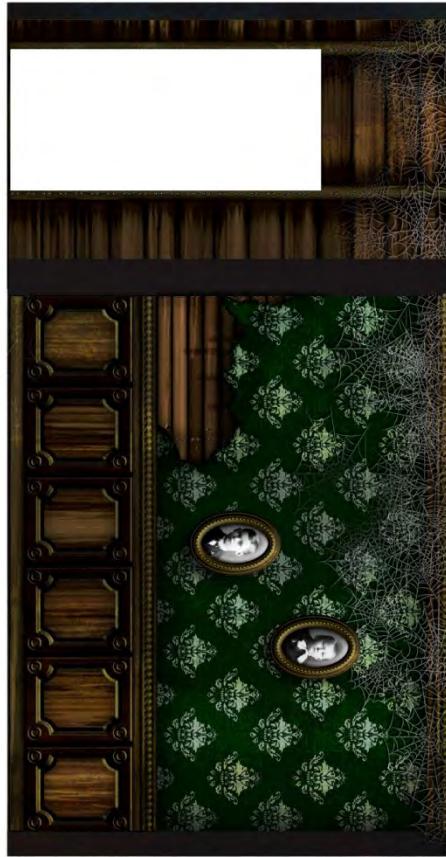

O



N

T joint on top of piece K



P

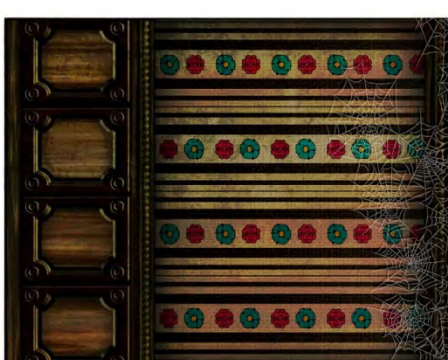

Q

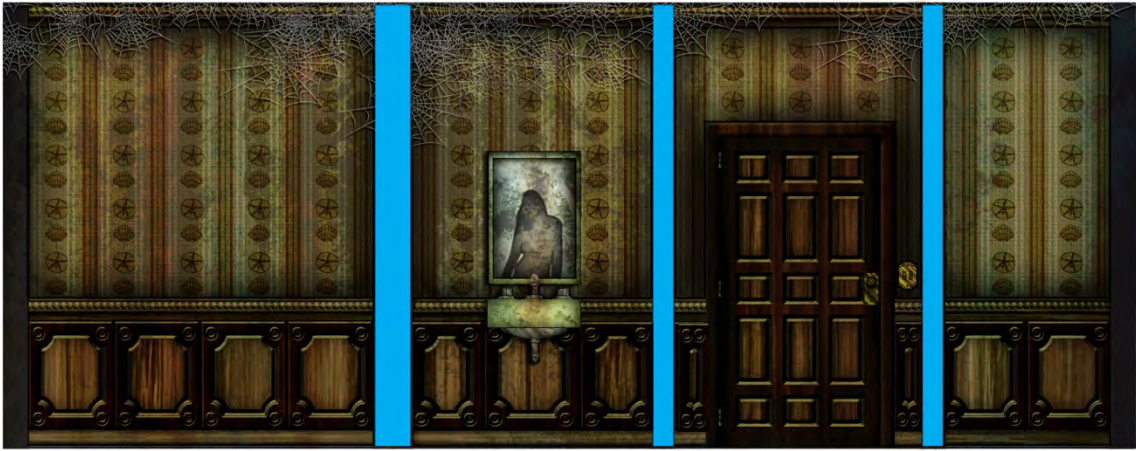

R

T joint on top of piece K



R

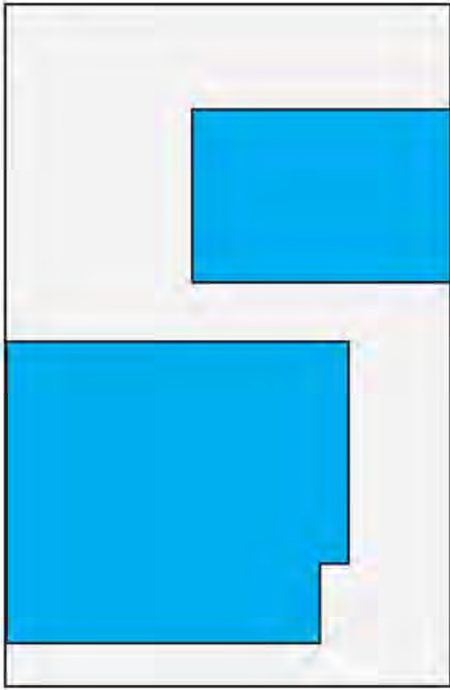

M

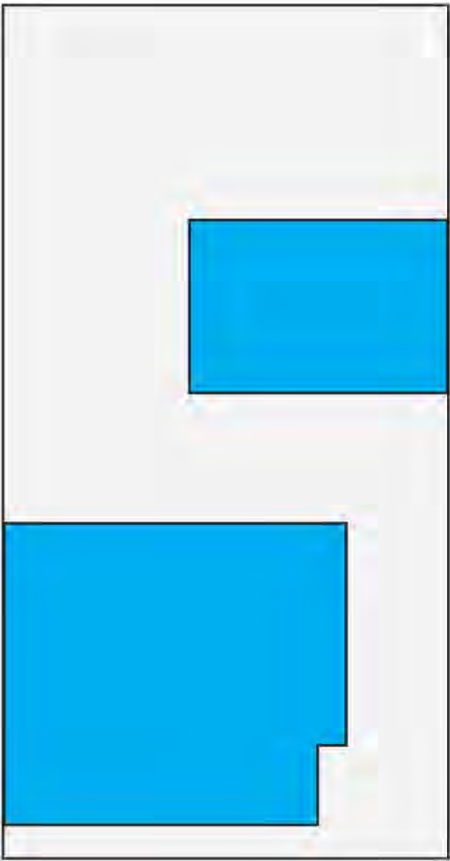

K

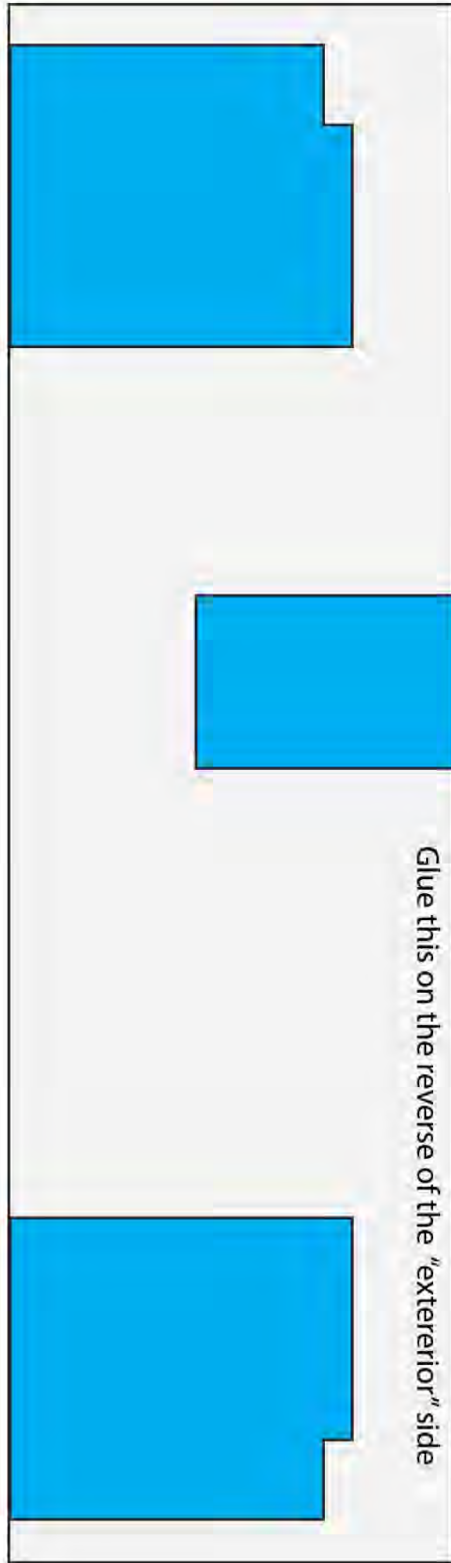

Template

Glue this on the reverse of the "exterior" side



# Second Floor

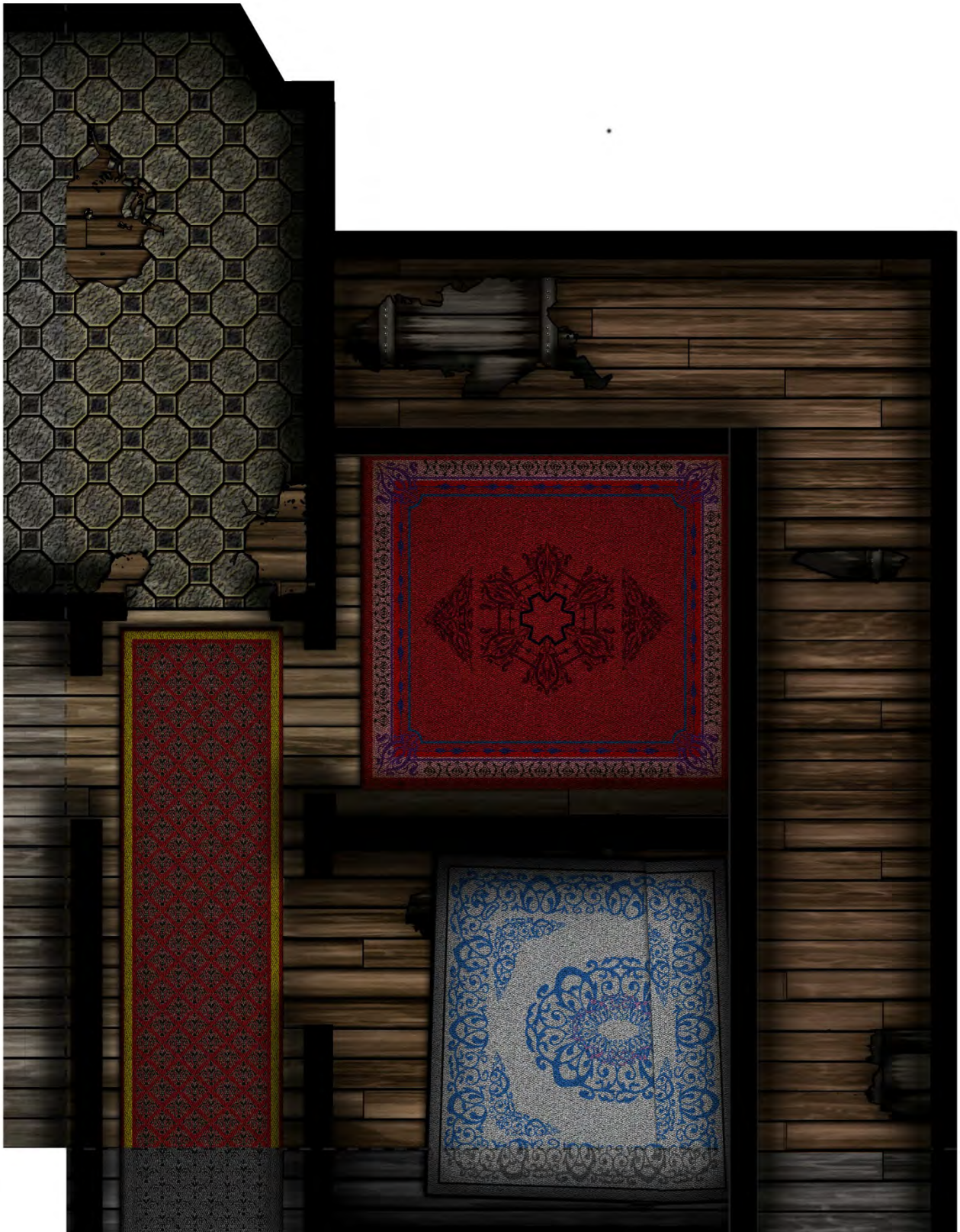







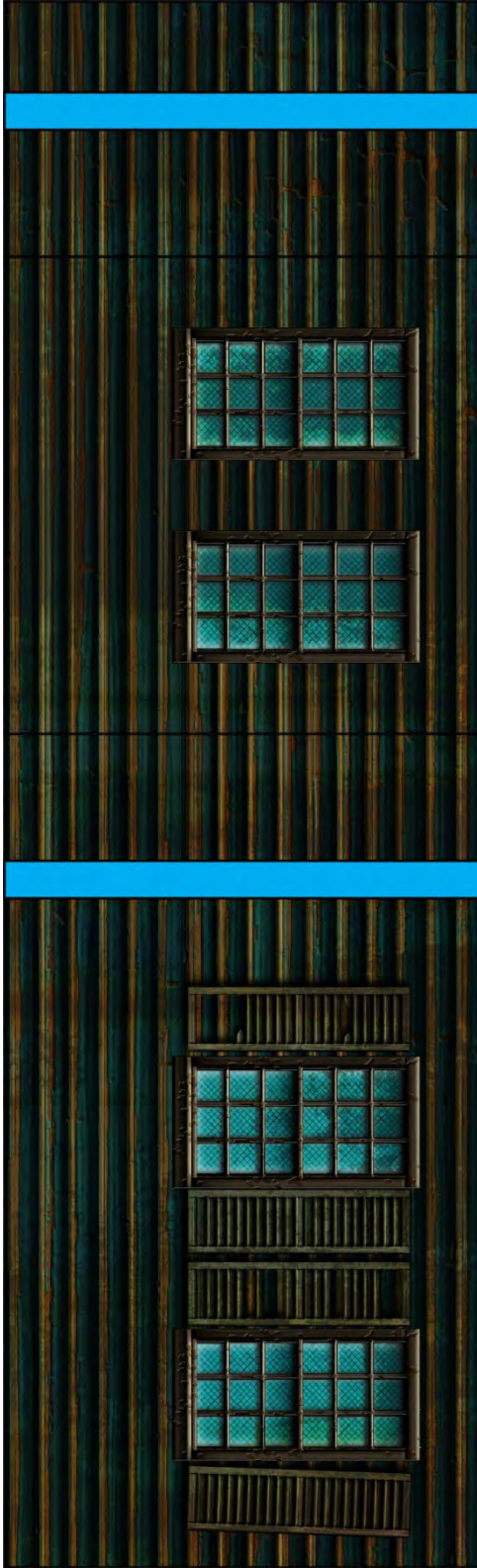

Exterior

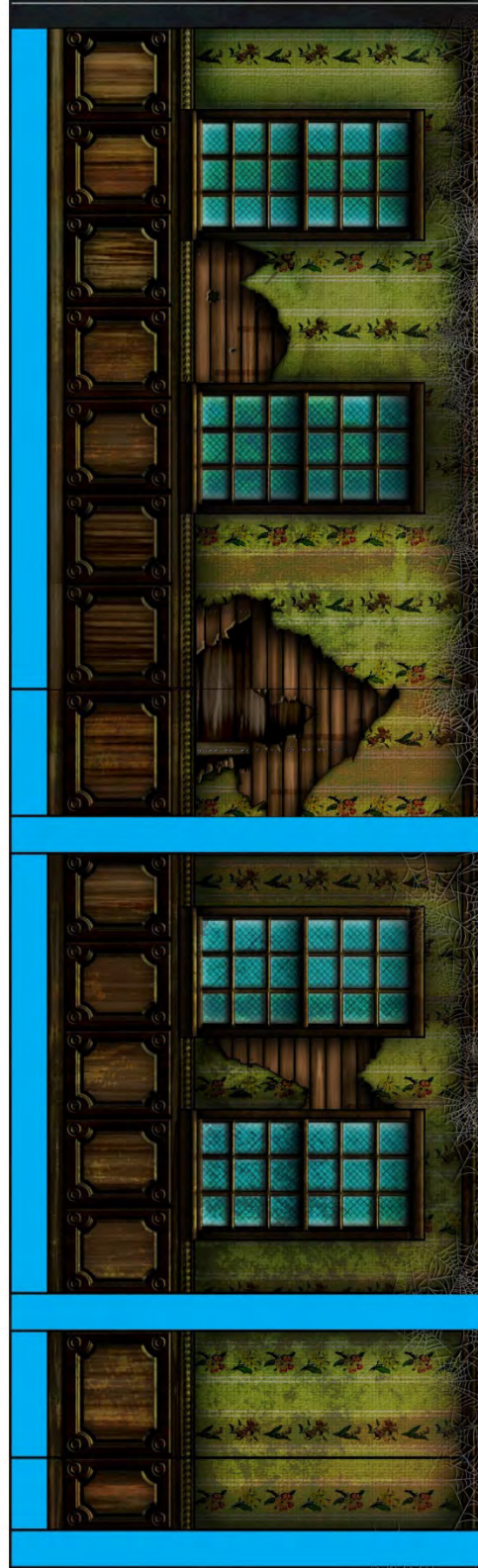

A Interior

**B**  
Interior



**Exterior**





C Interior



Exterior

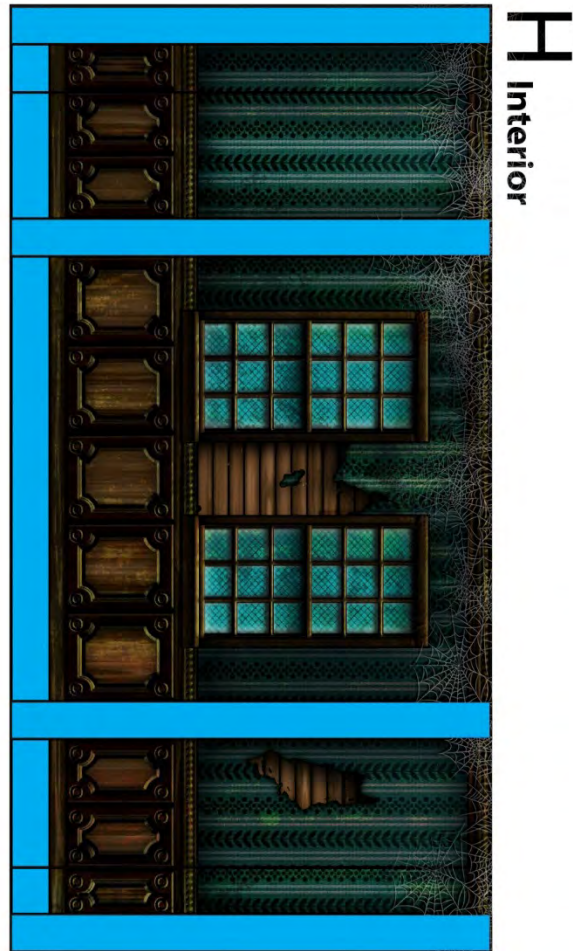

H Interior

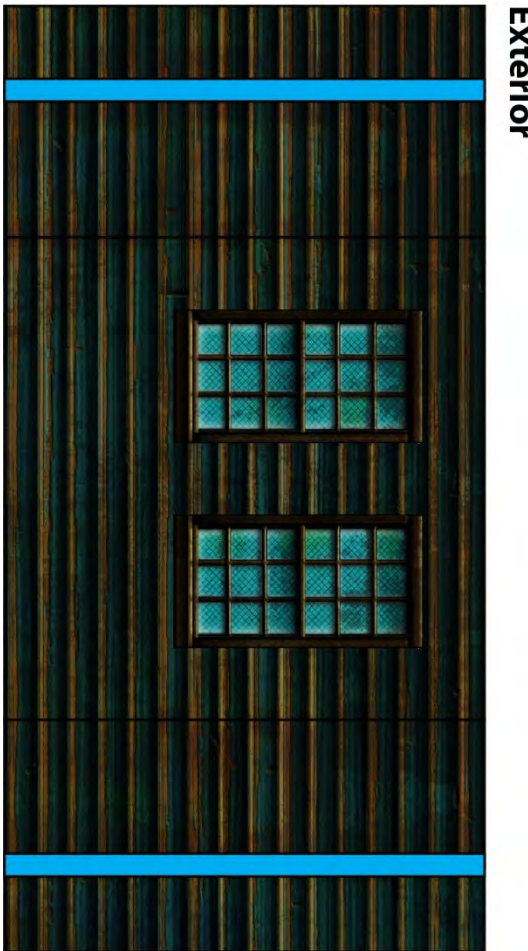

Exterior





Exterior



D  
Interior



Exterior

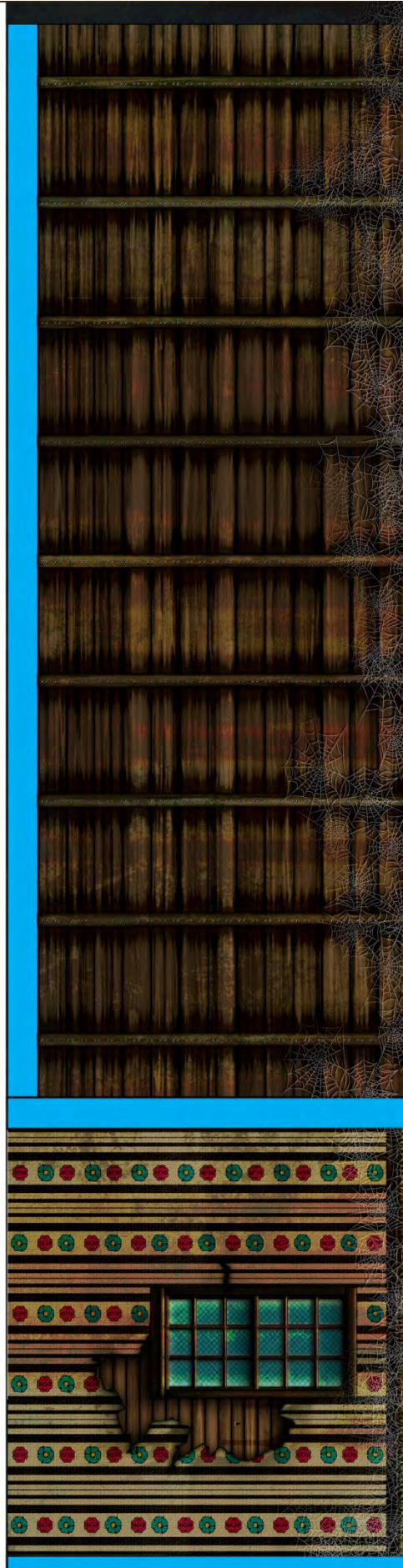

Interior

# F

Interior

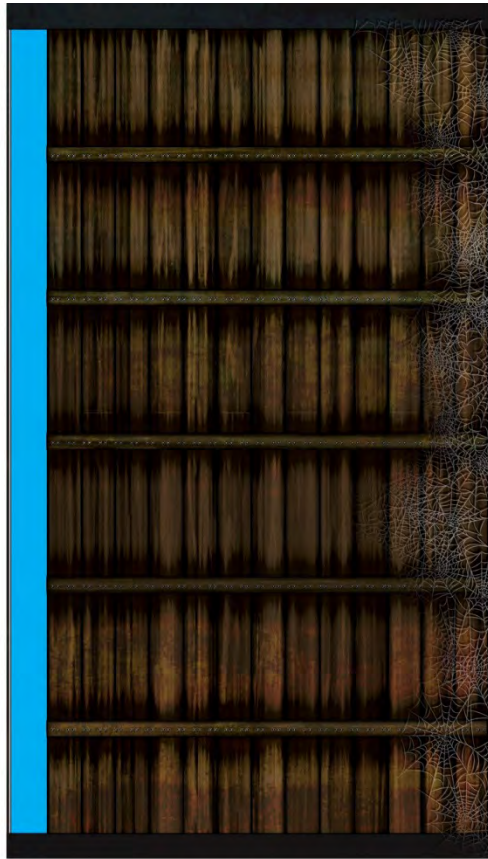

Exterior



# I

Interior

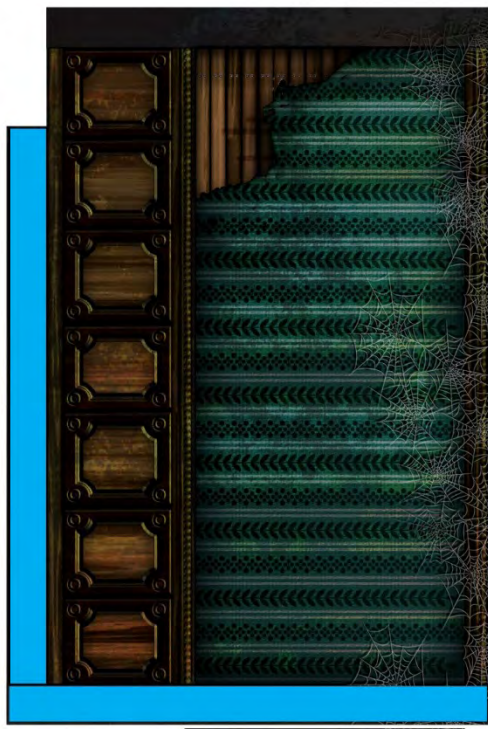

Exterior



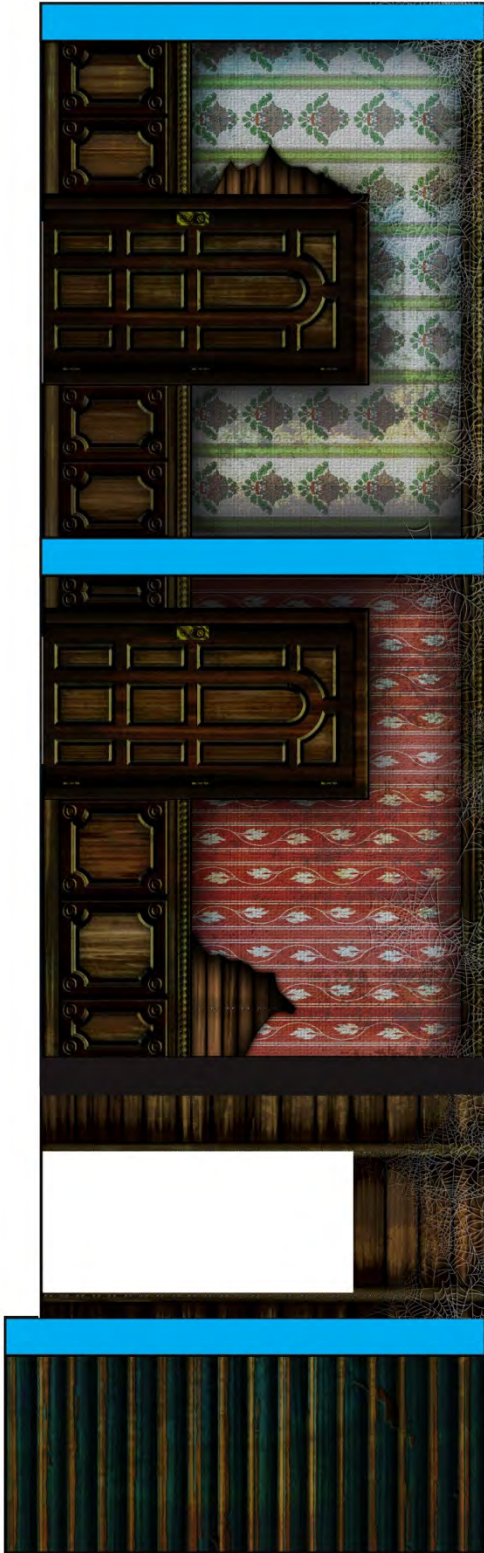

Exterior

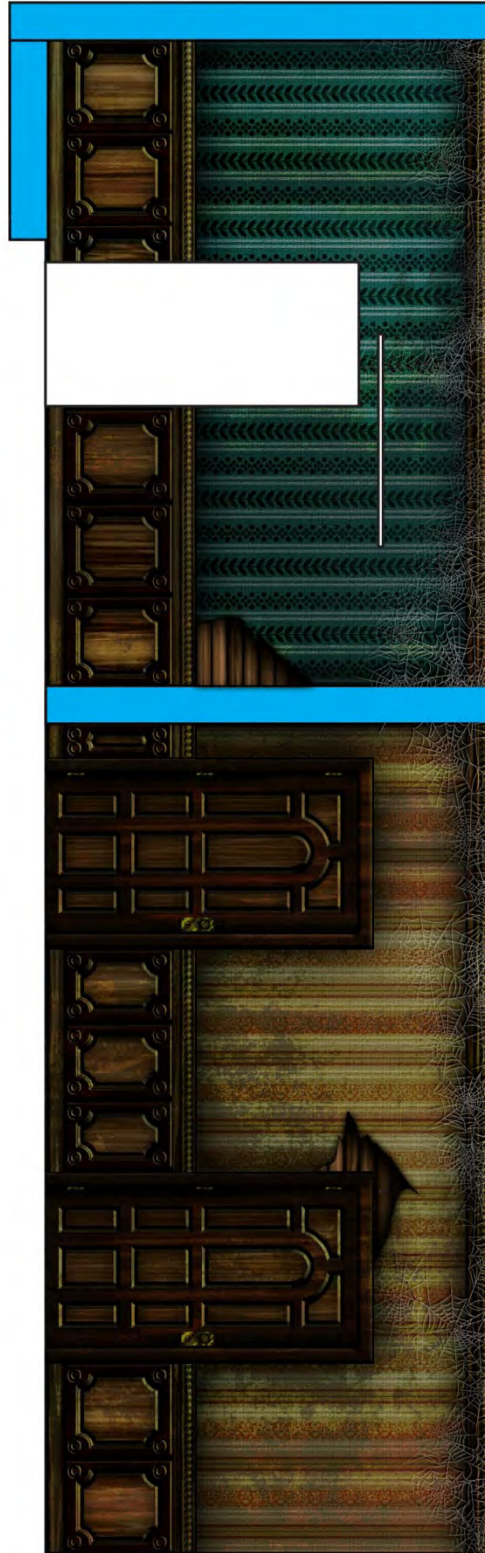

G Interior



Exterior



Interior



Exterior

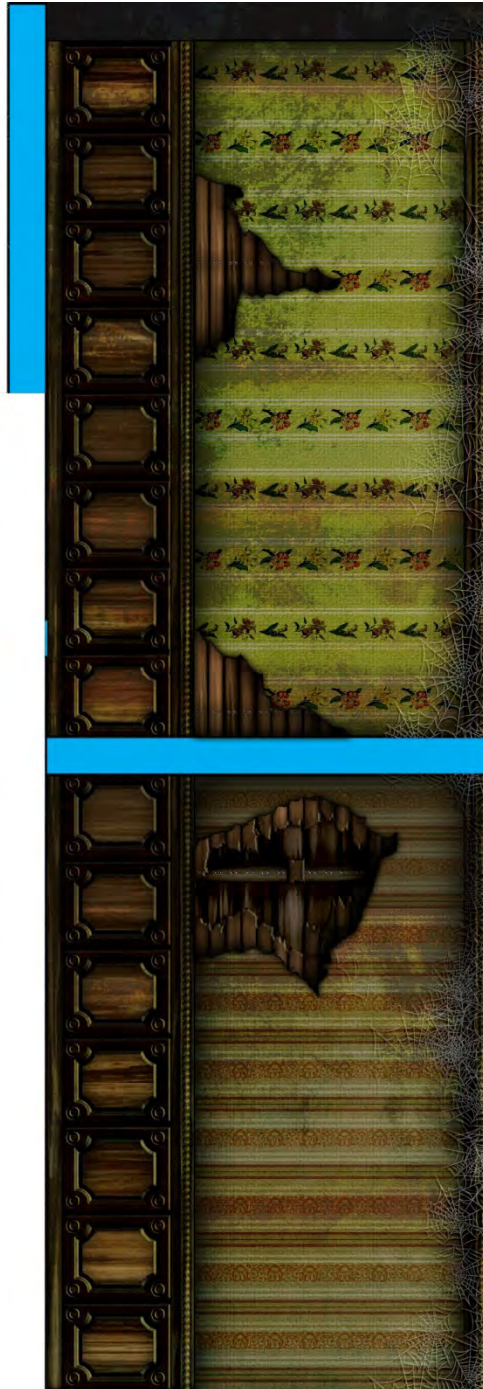

K Interior

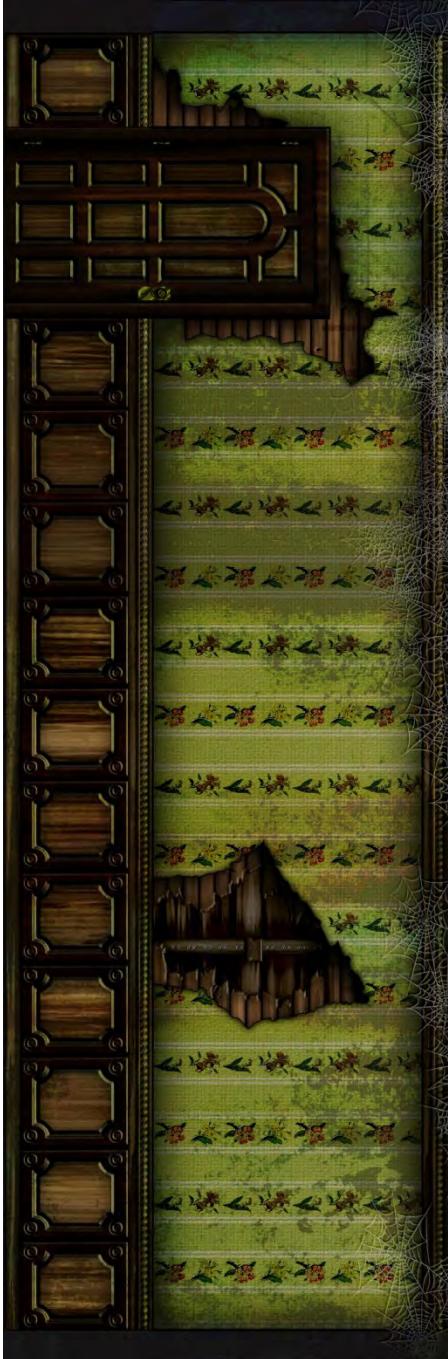

Exterior

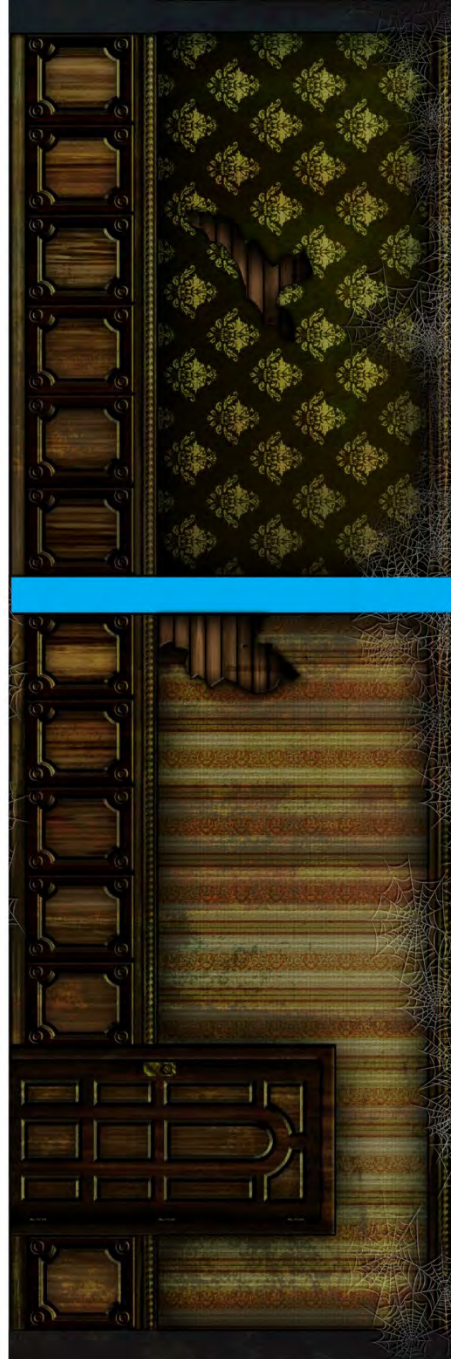

Interior

**M**

Interior



Exterior



**P**

Interior



Exterior





**N**  
Interior



Exterior



**O**  
Interior



Exterior



# Q Interior



# R Interior

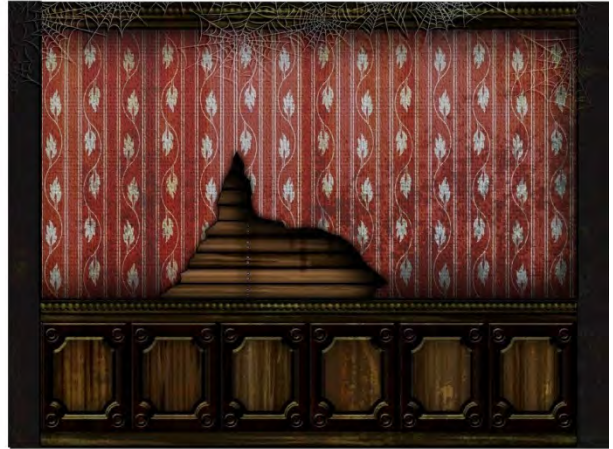

# Exterior



# Exterior

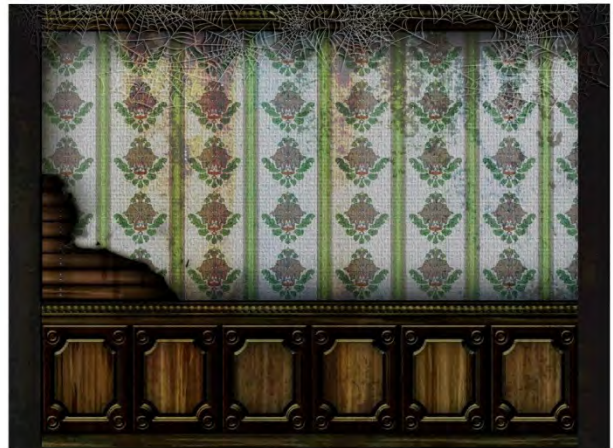

# T Interior

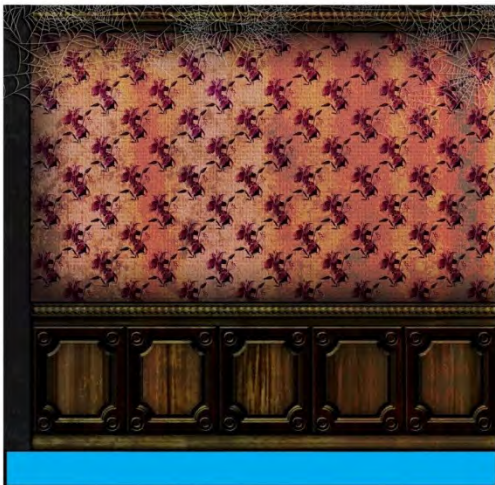

# Exterior



# S Interior

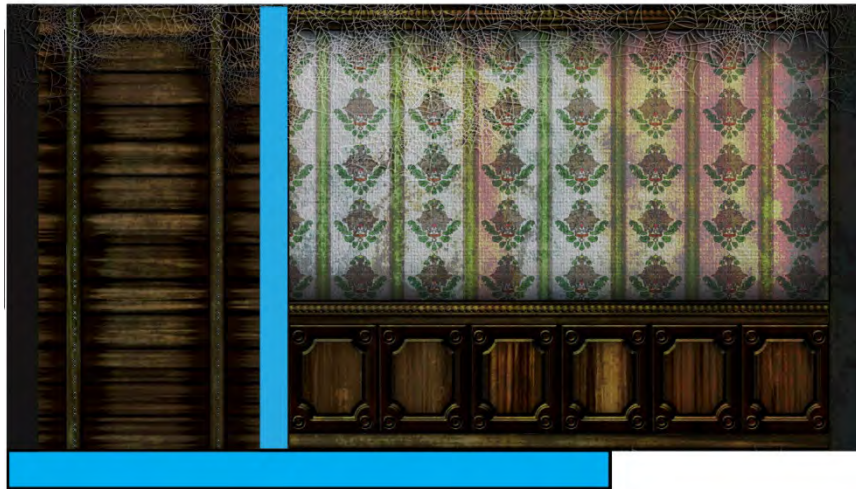

# Exterior

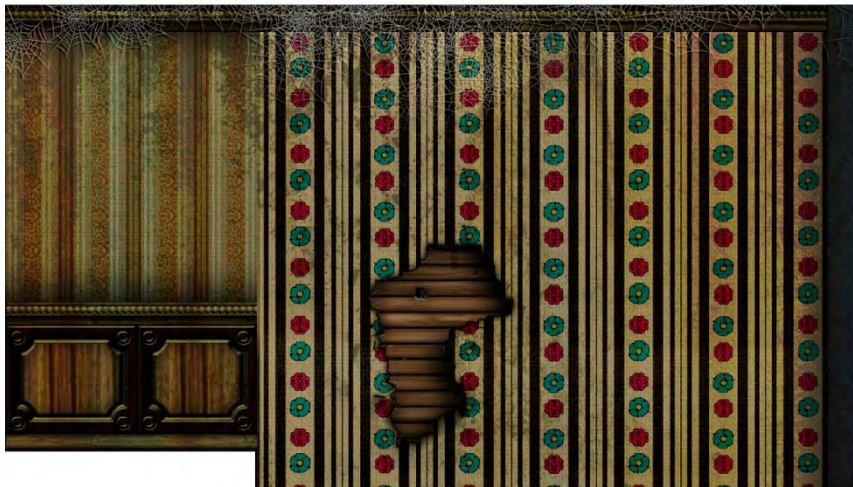

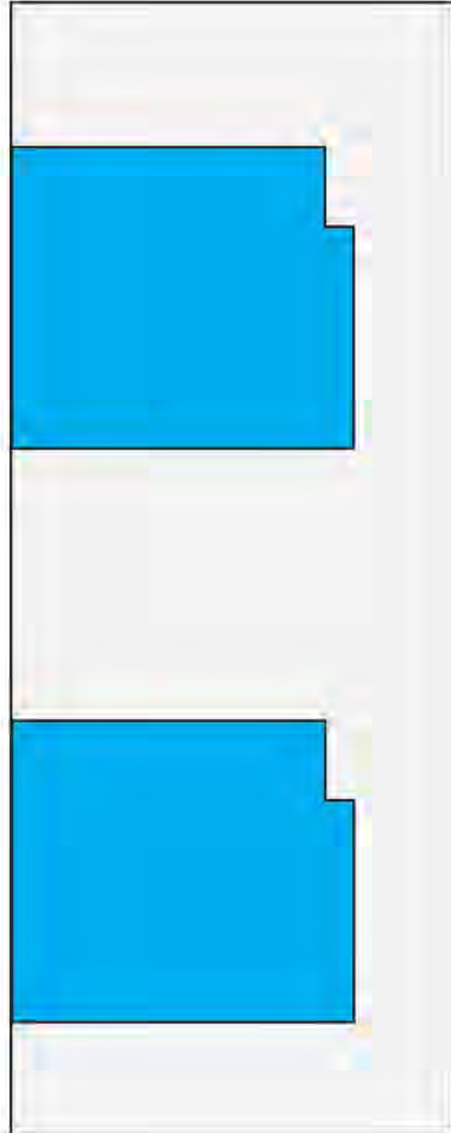
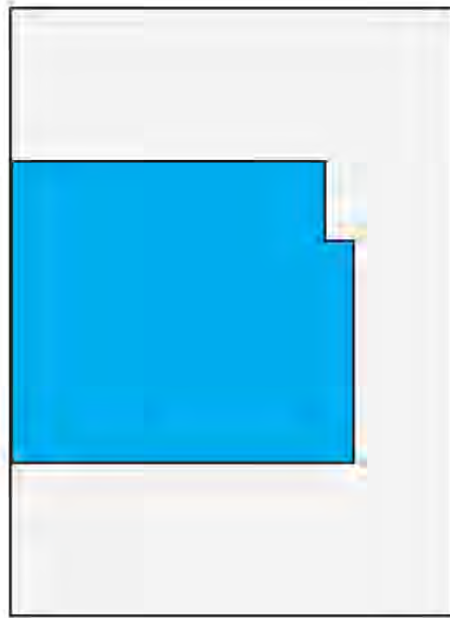
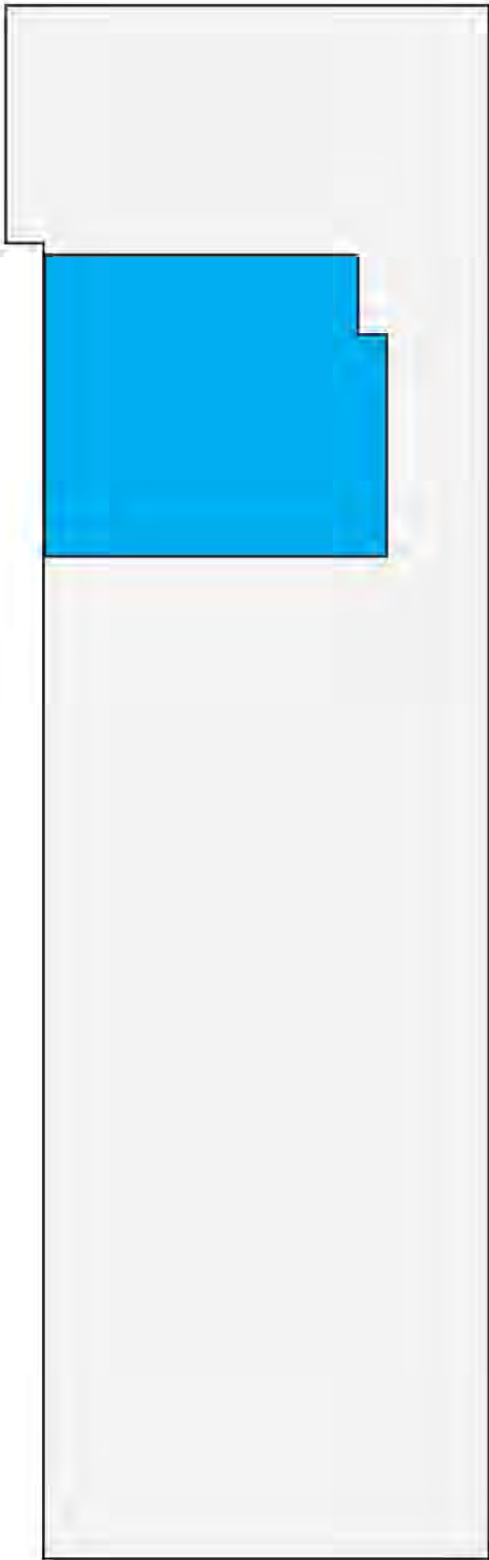

# Attic

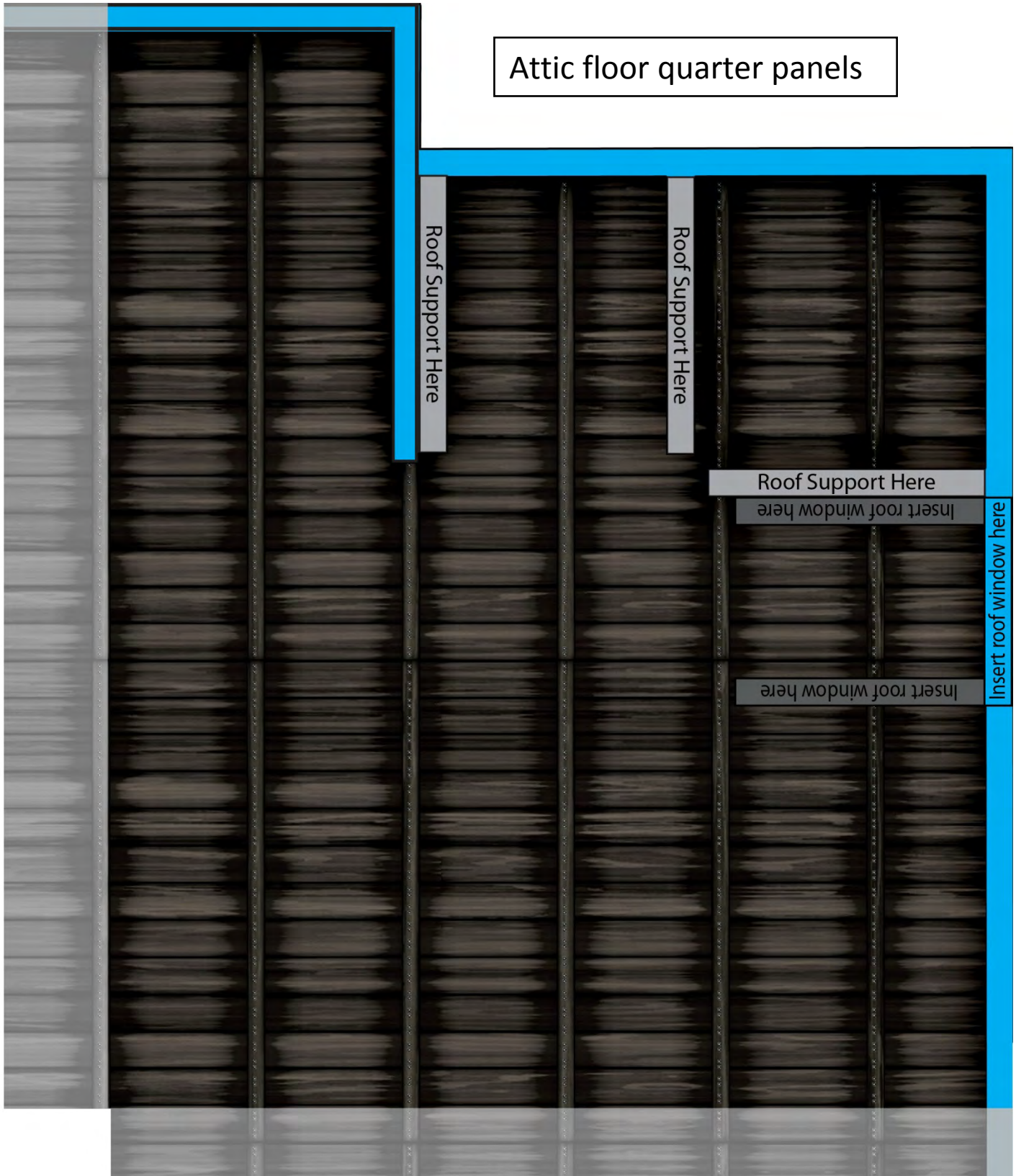



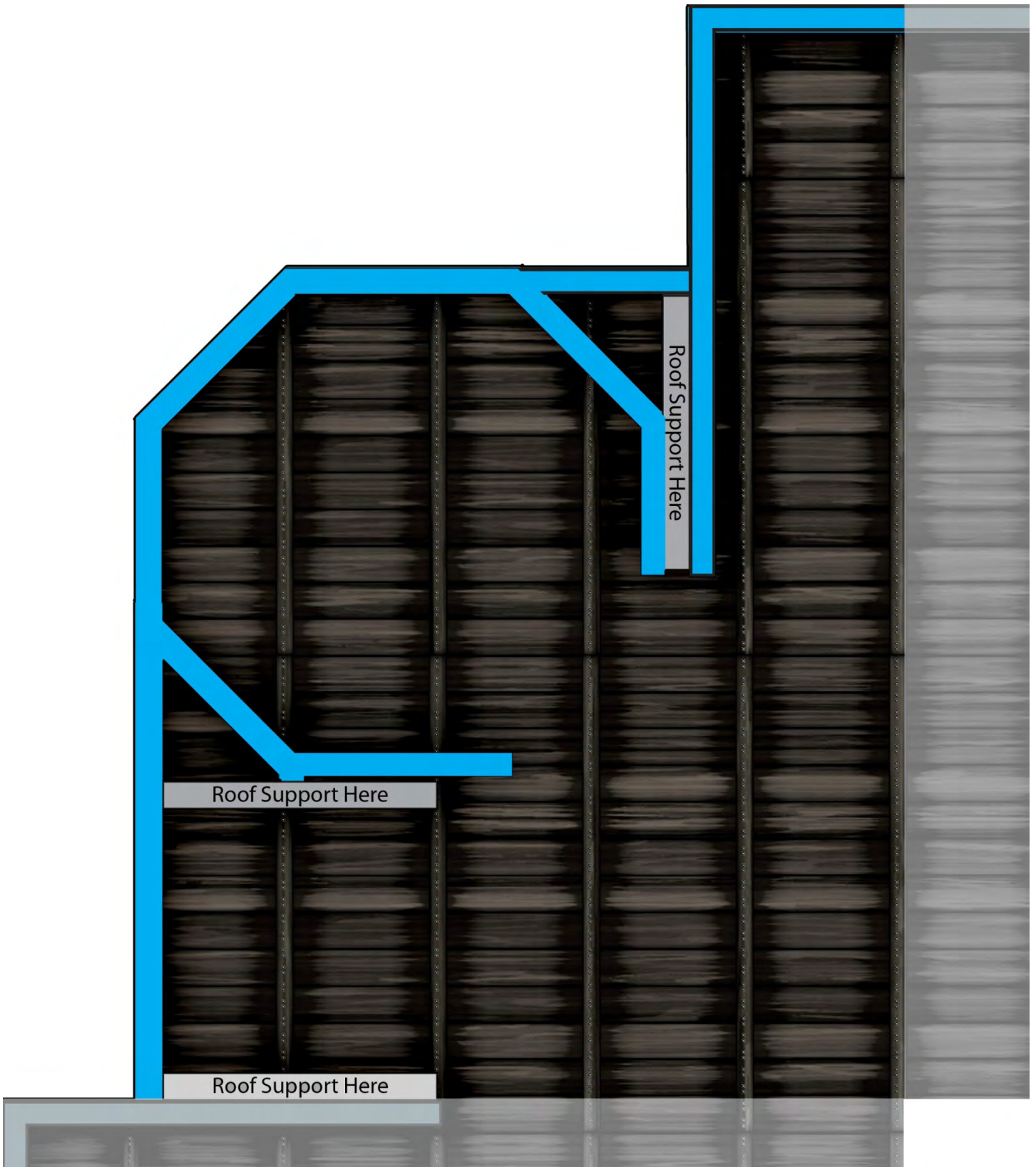





Attic Tower  
1 wall

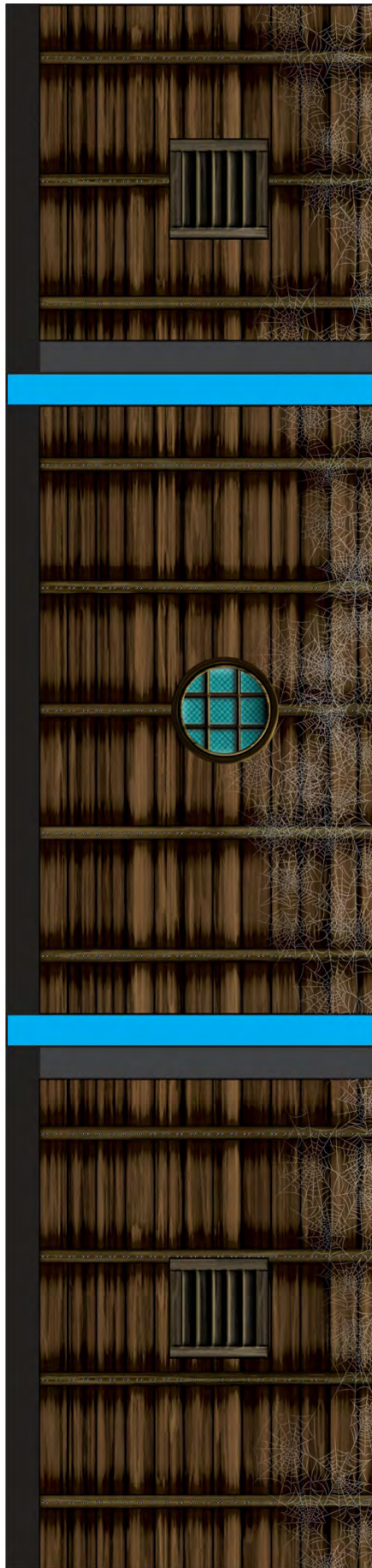

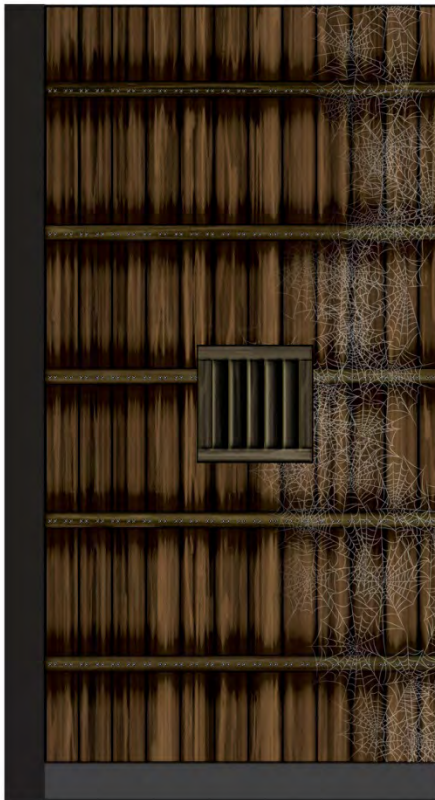
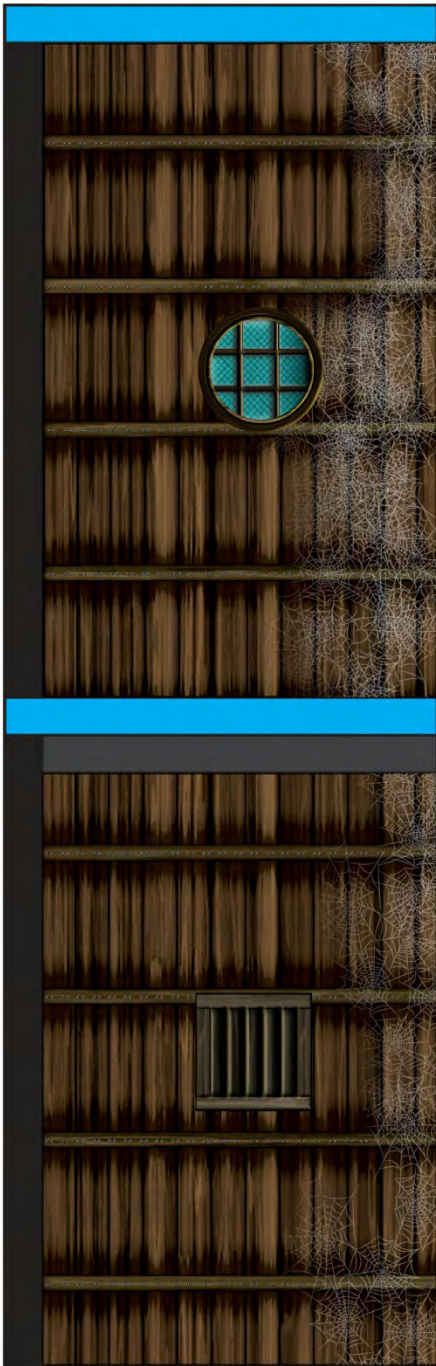

Attic Tower  
2 wall

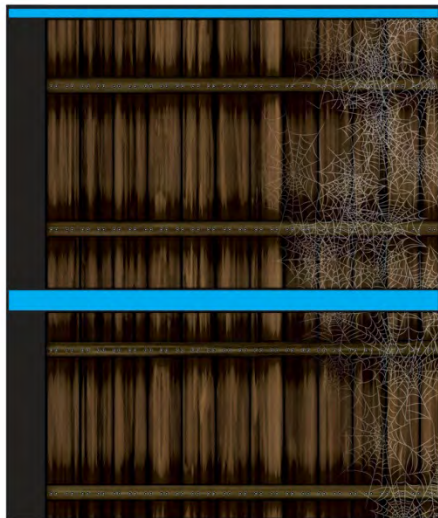
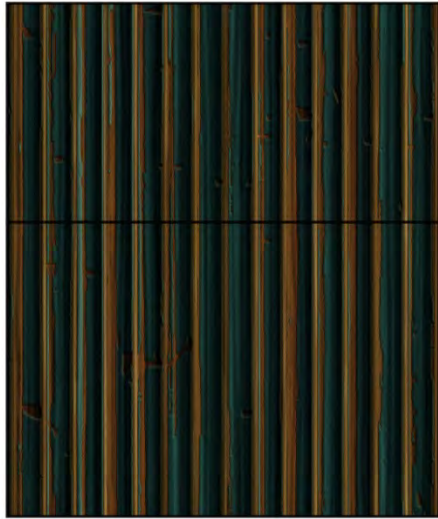

Attic Tower  
3 wall

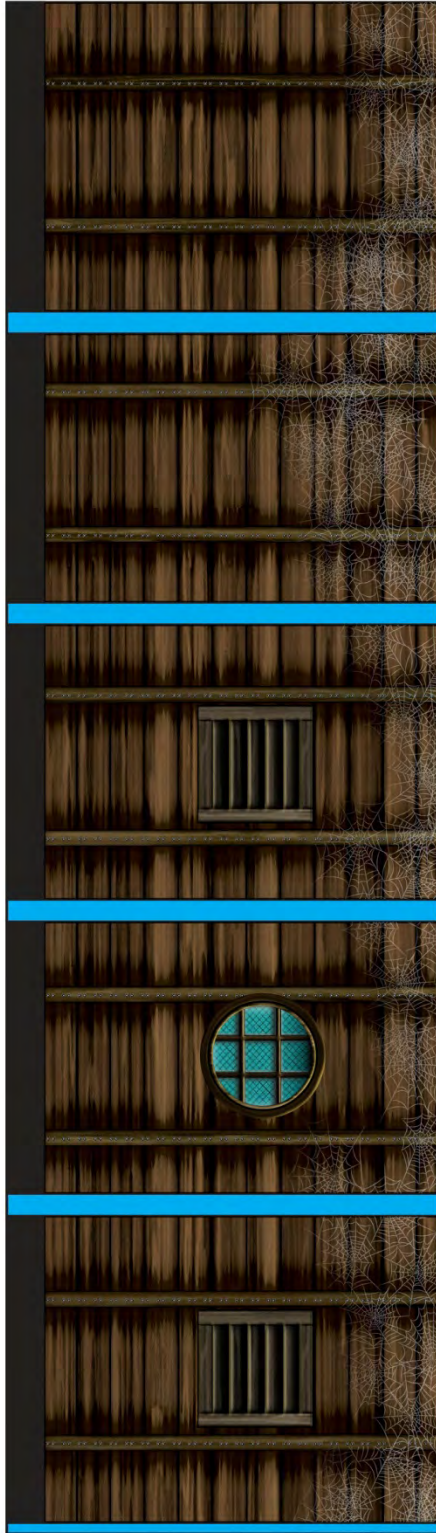

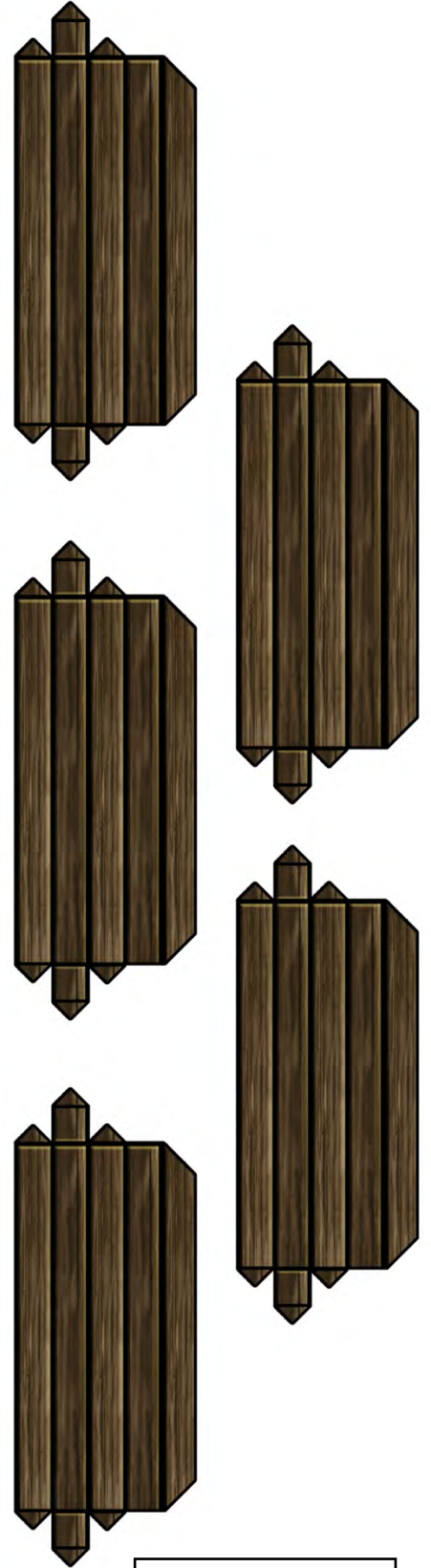
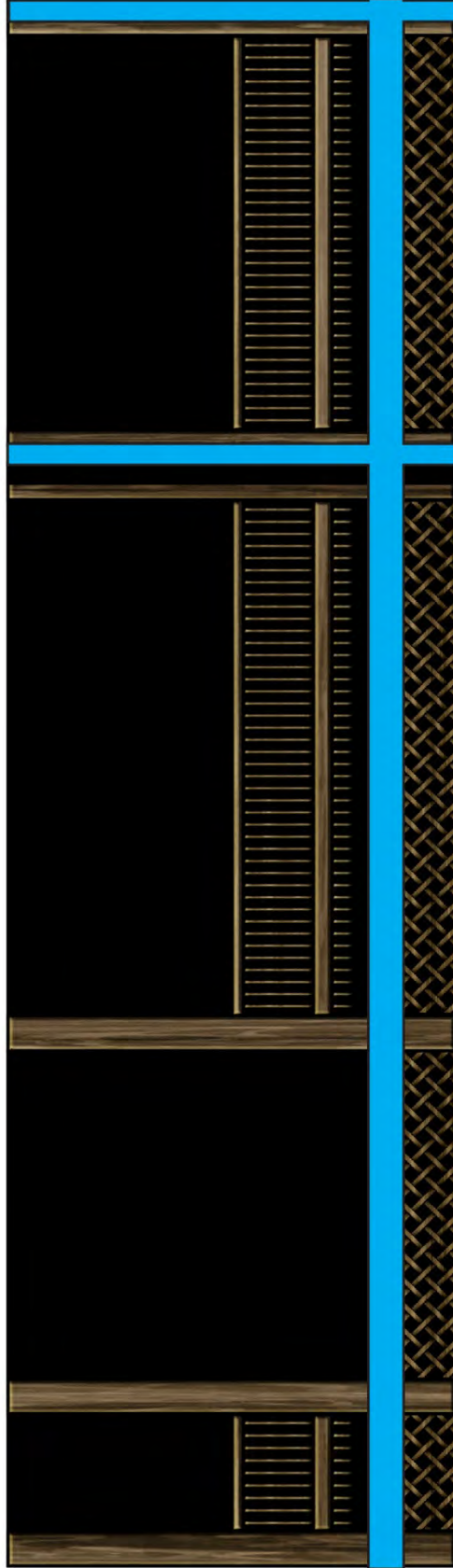
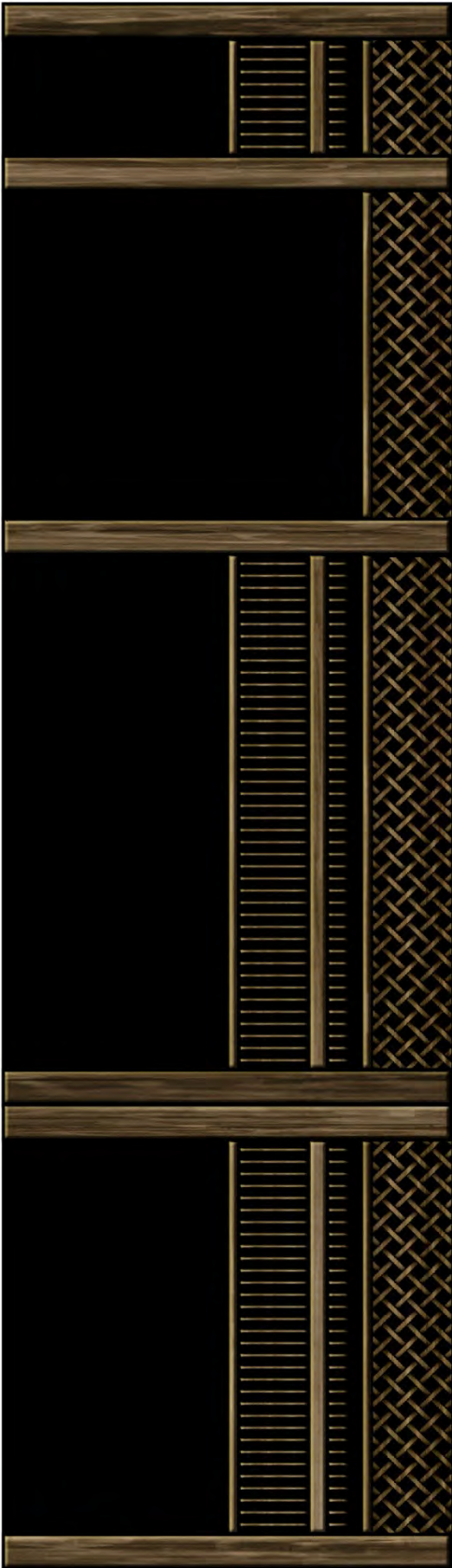

Front porch

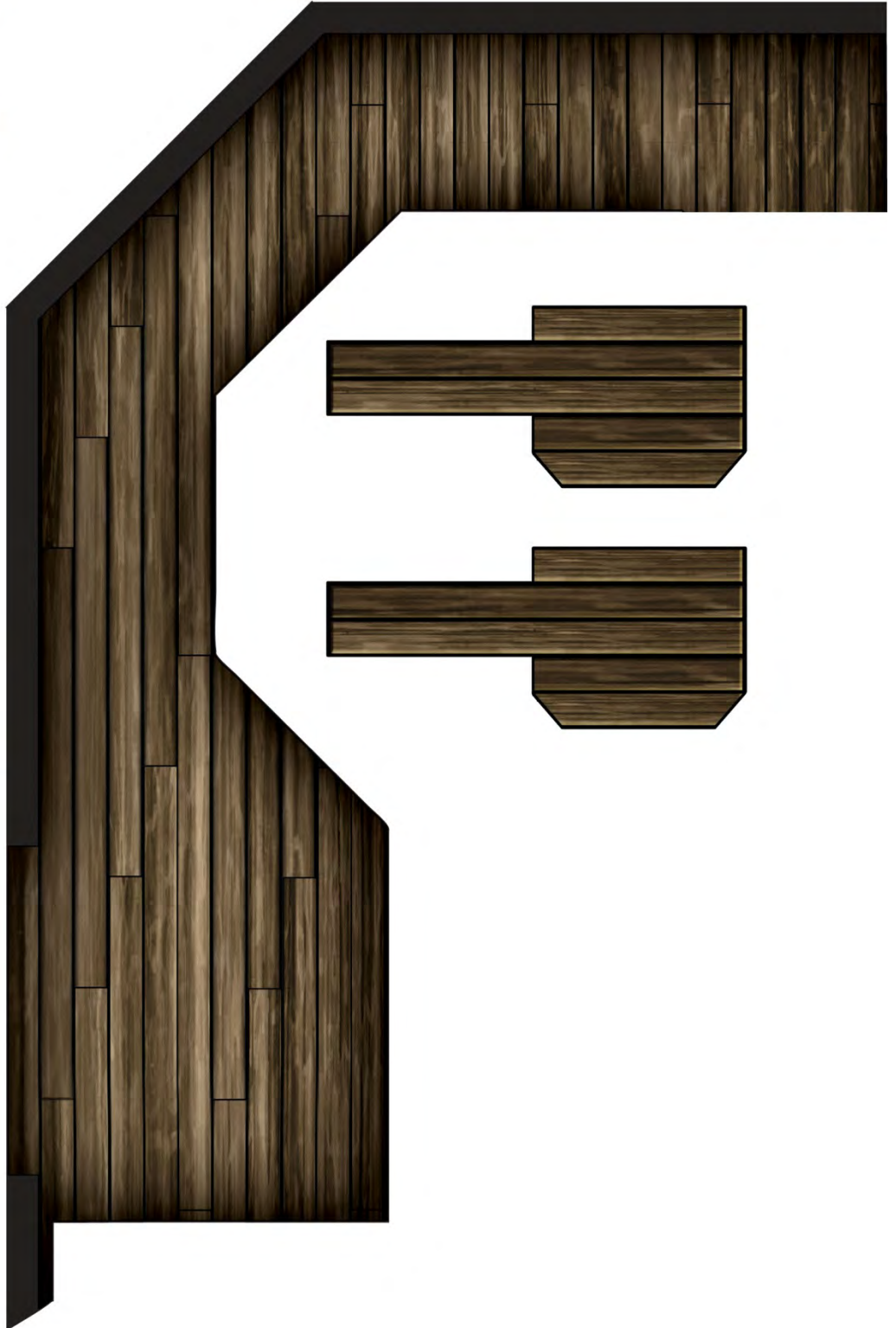
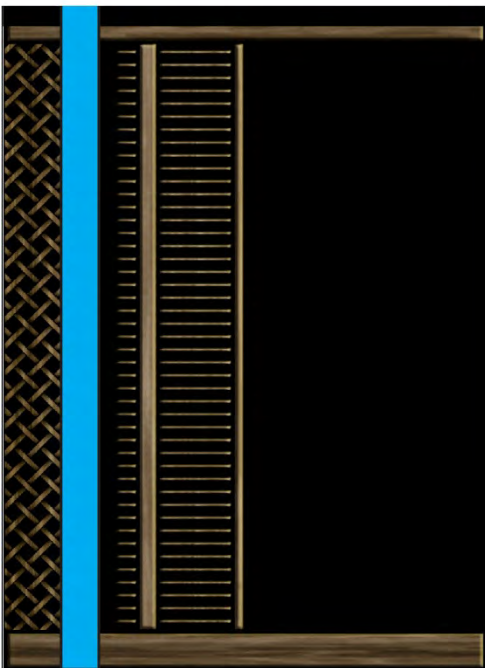
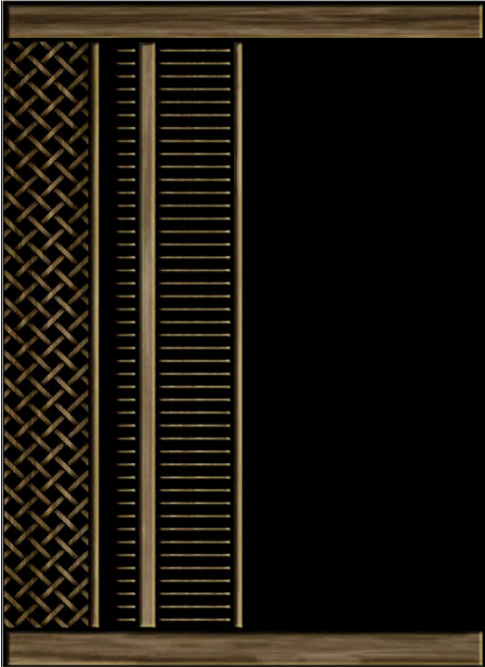

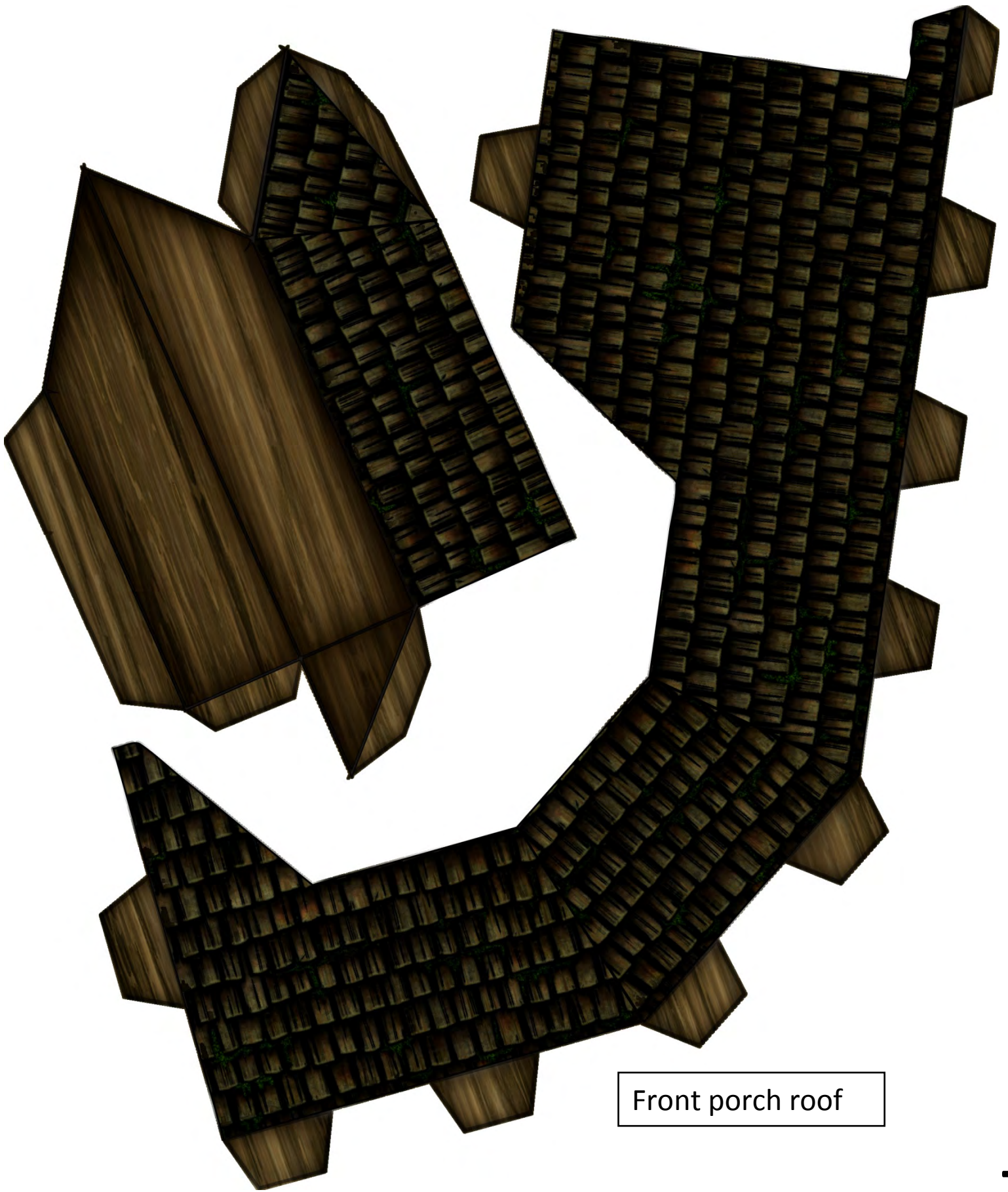

Front porch roof

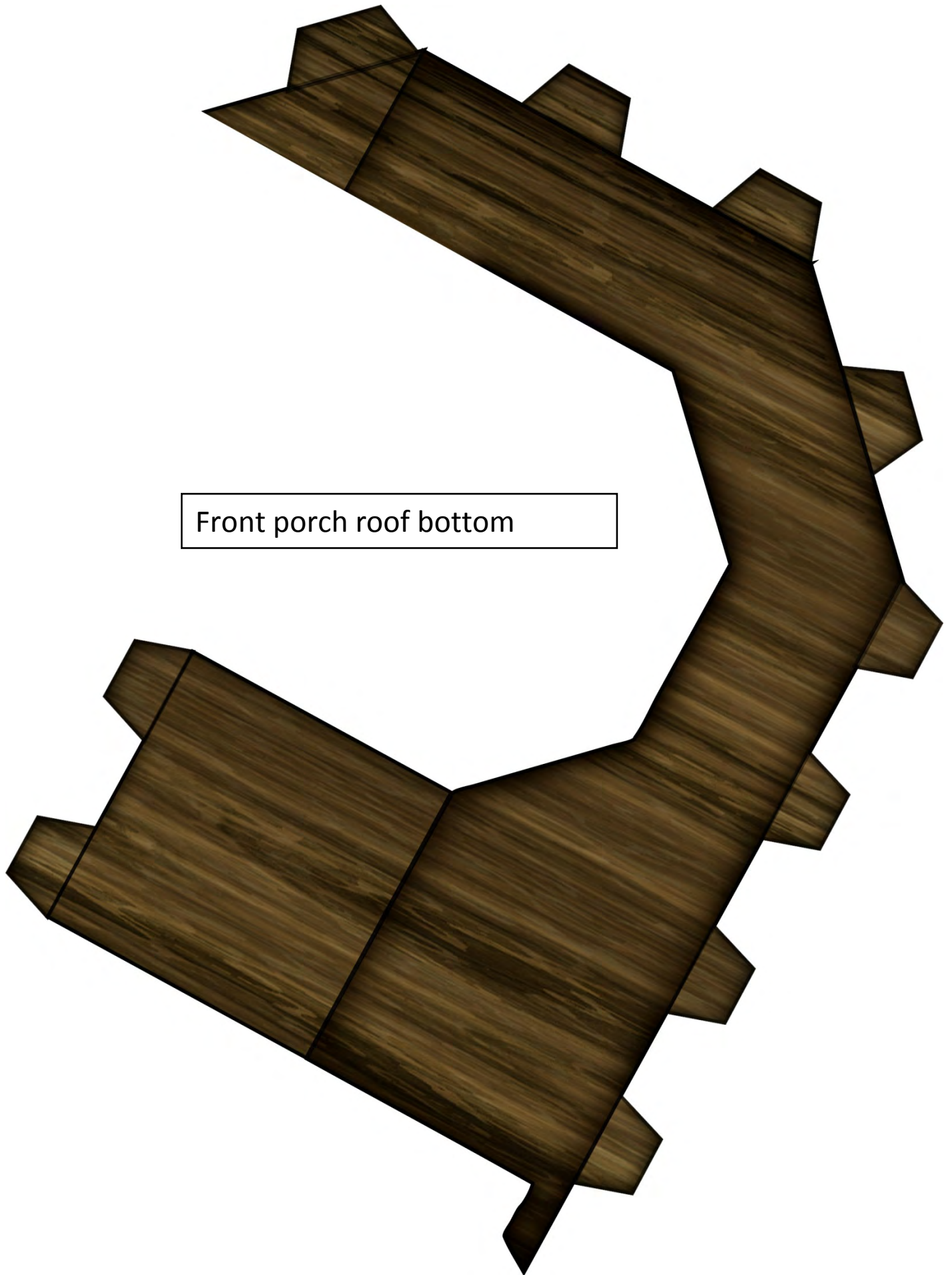

Front porch roof bottom



Bottom step



Top step



↑  
Mount on 5mm foamcore. the edge should be wrapped around and glued to bottom side

Stair wrapper, fold 180 degrees, glue around sides and back of stair steps



Bottom step



Top step



↑  
Mount on 5mm foamcore. the edge should be wrapped around and glued to bottom side

Stair wrapper, fold 180 degrees, glue around sides and back of stair steps





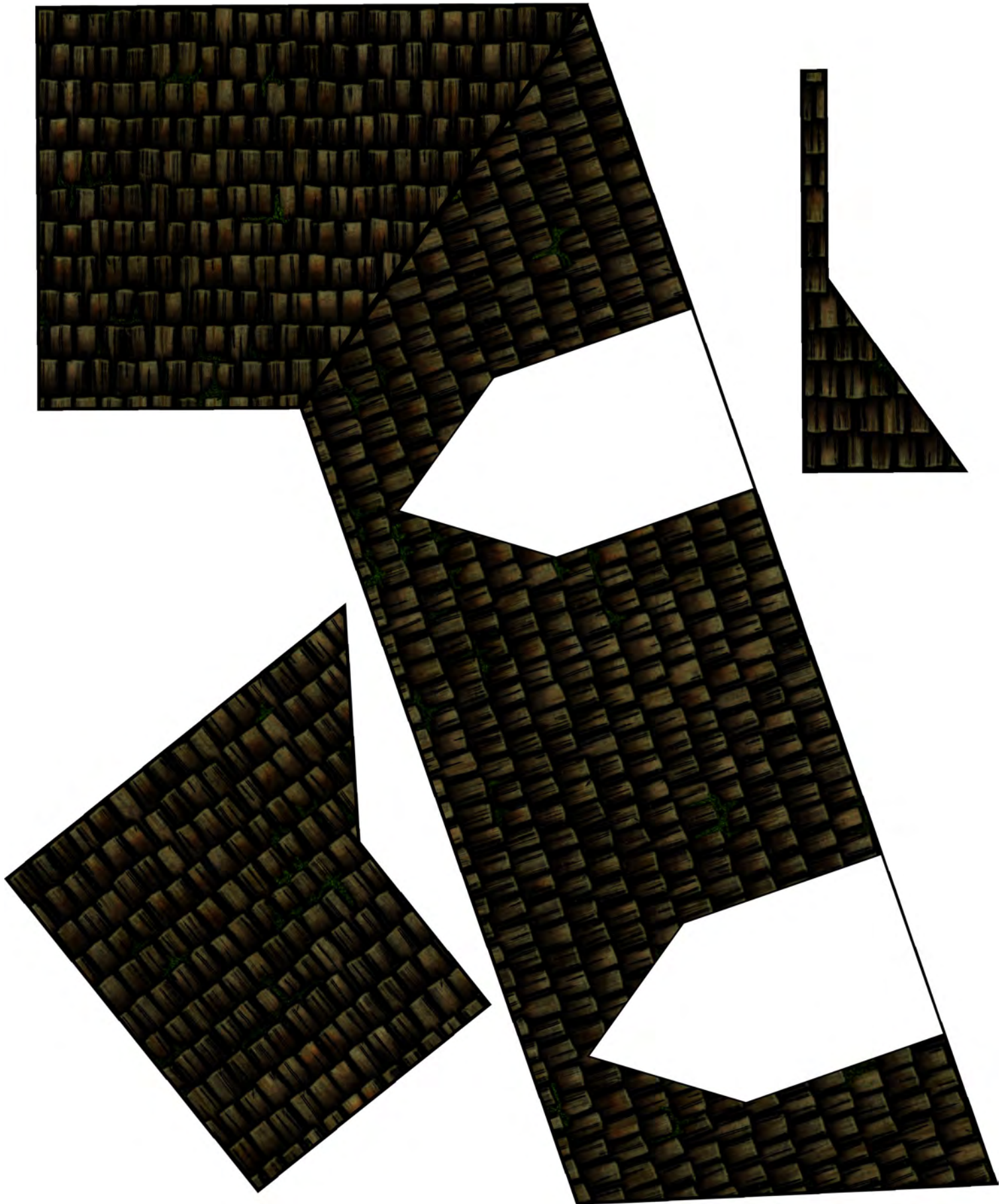

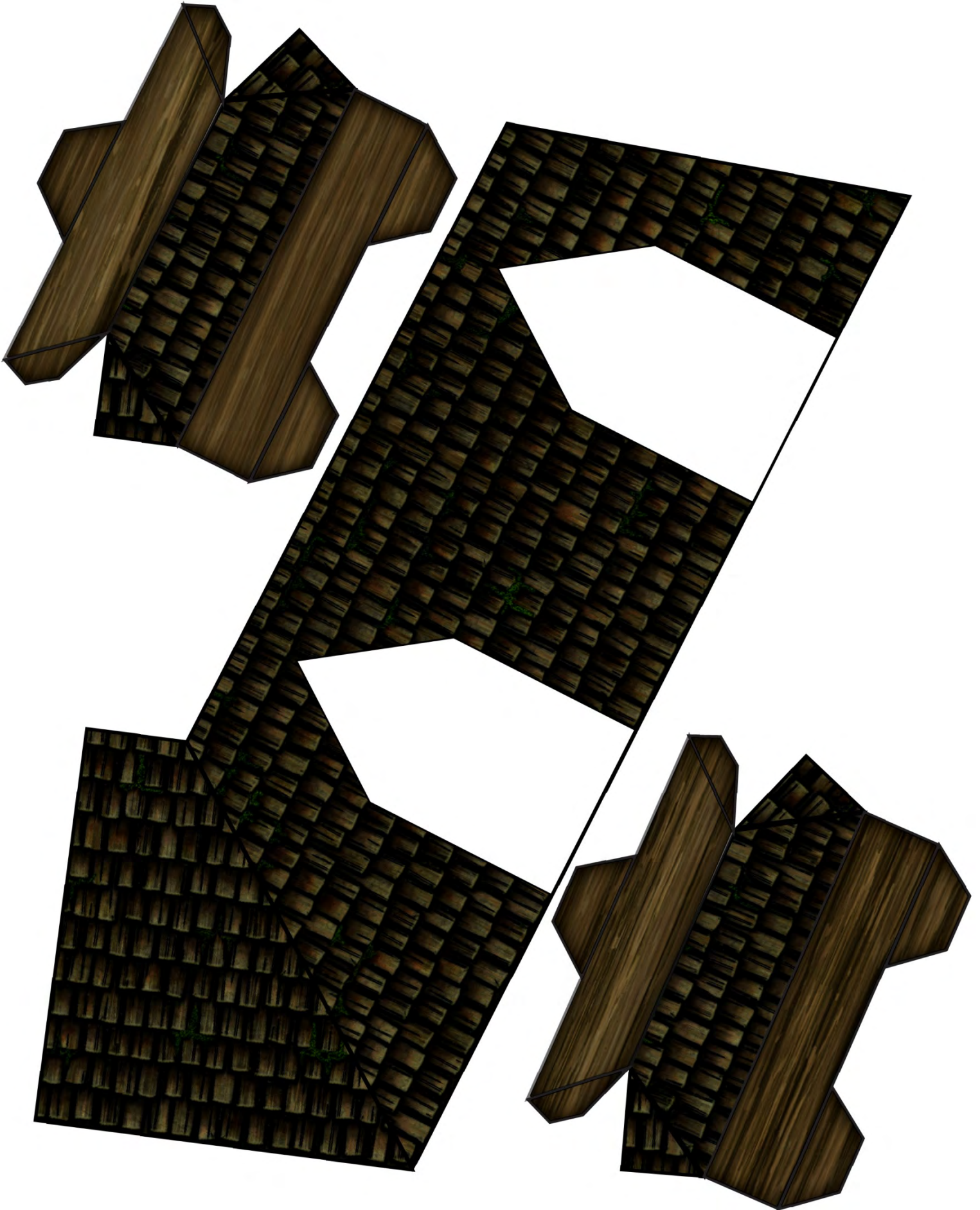

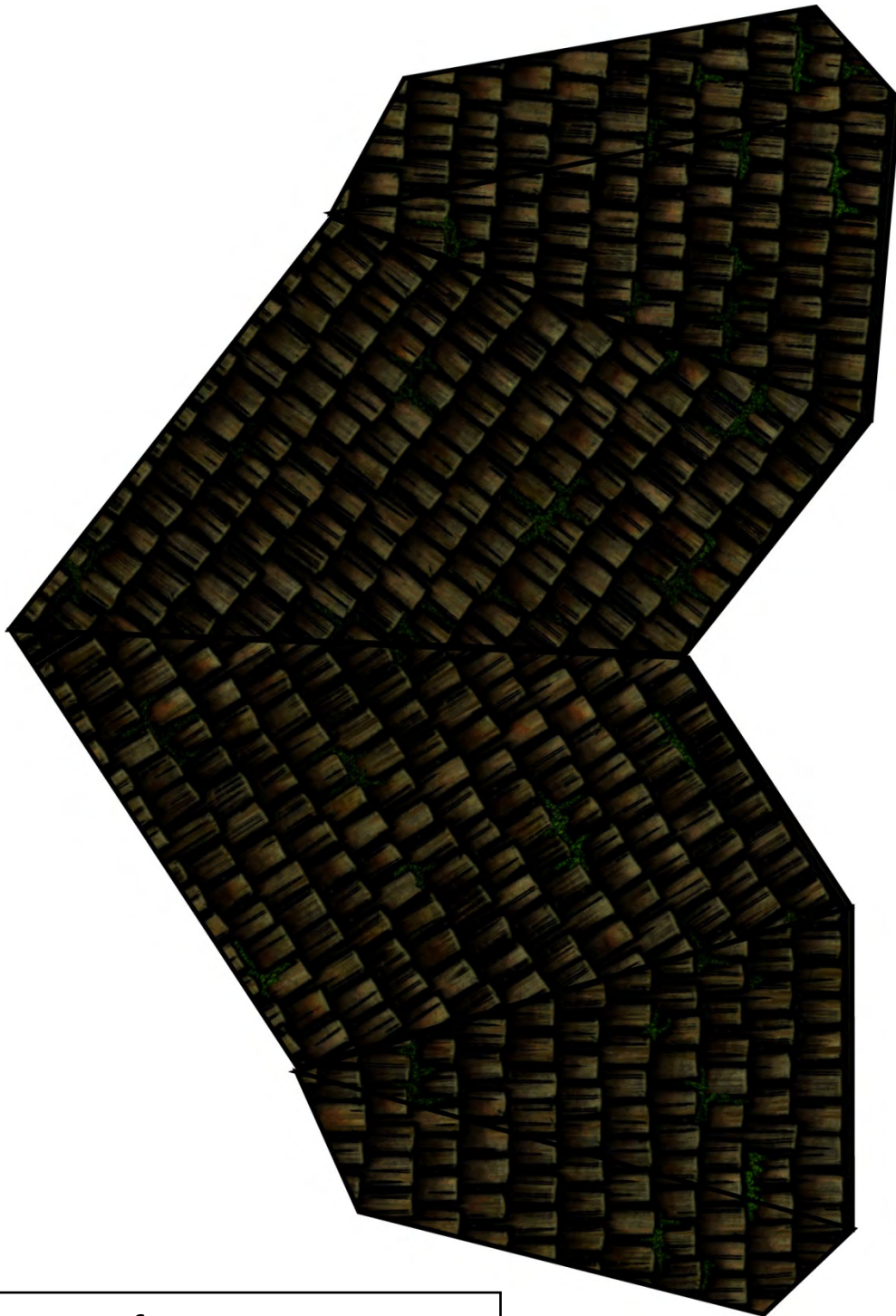

Attic roof, corner transition



Attic 8 sided  
tower cover

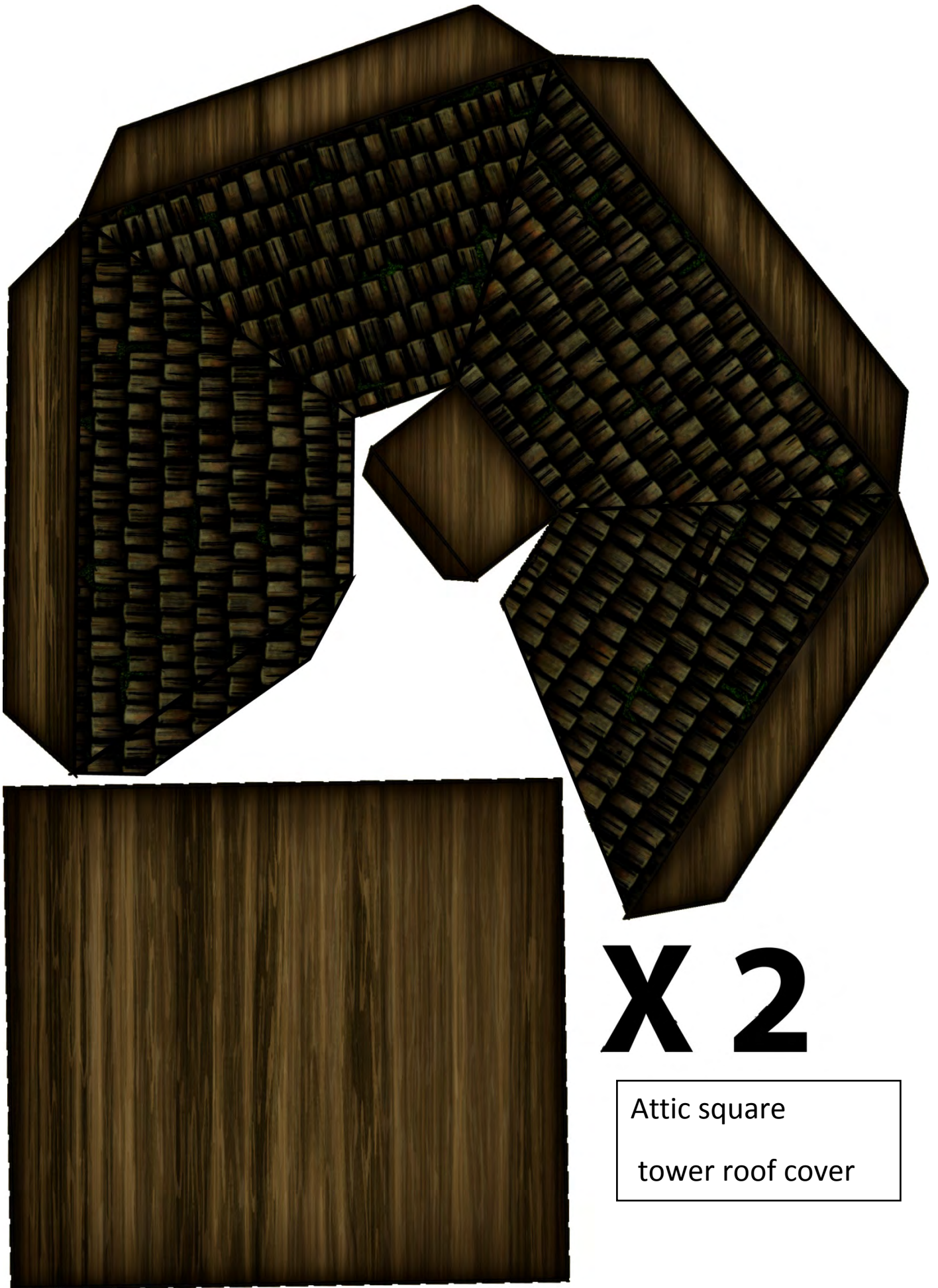

**X 2**

Attic square  
tower roof cover

Roof support pieces for attic

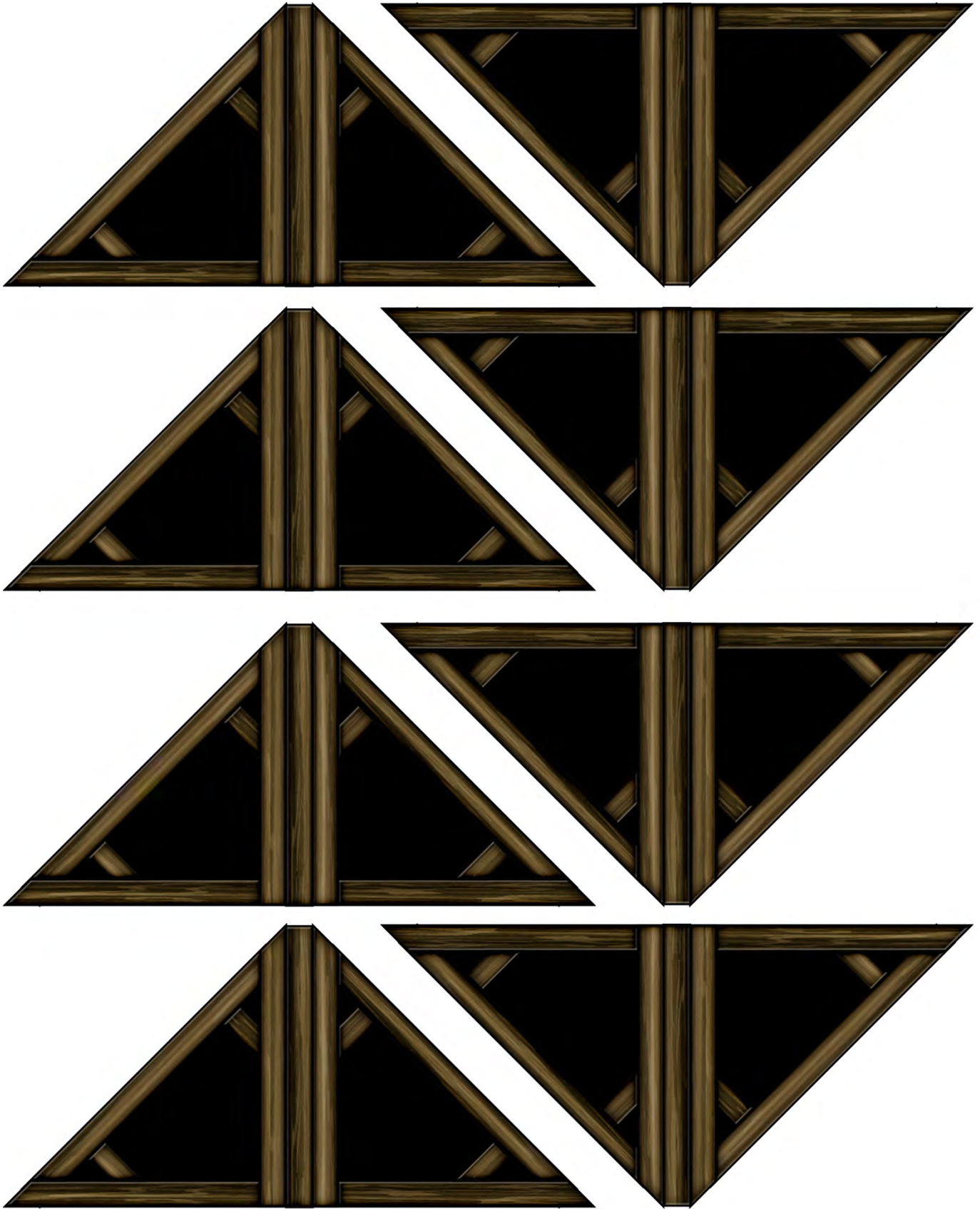



# Props and Furniture

Secret sliding door panels

1st floor



2nd floor



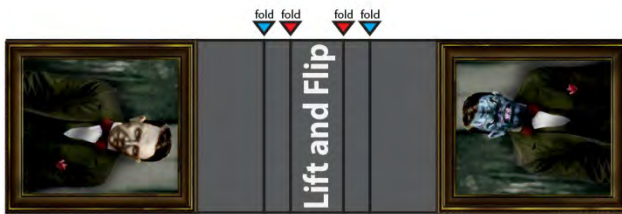
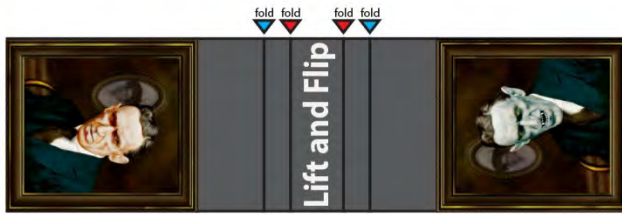
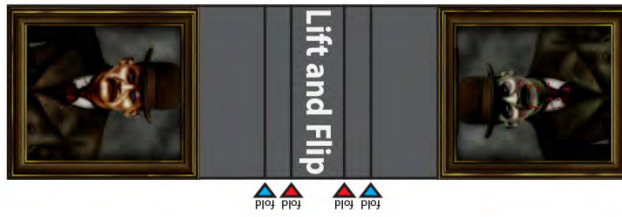
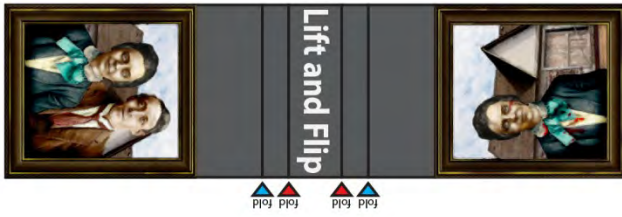
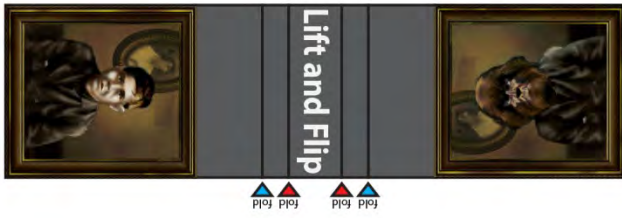
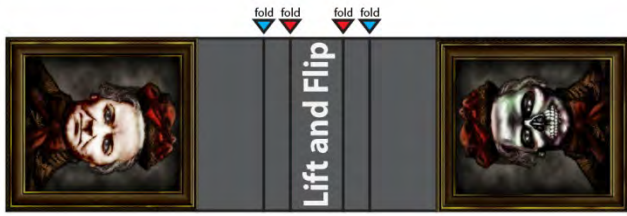



Rabbit, and wrap around exposed edge

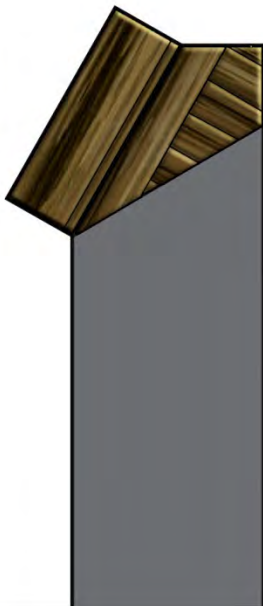
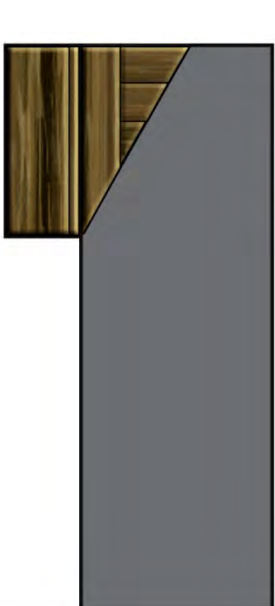
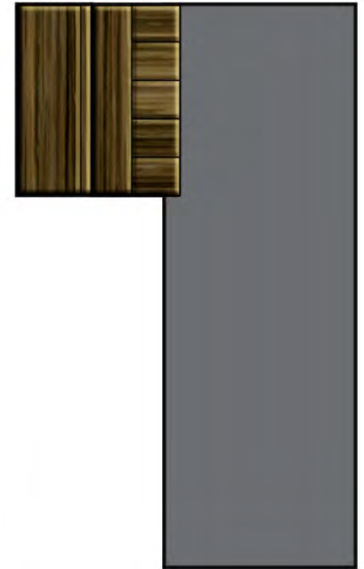
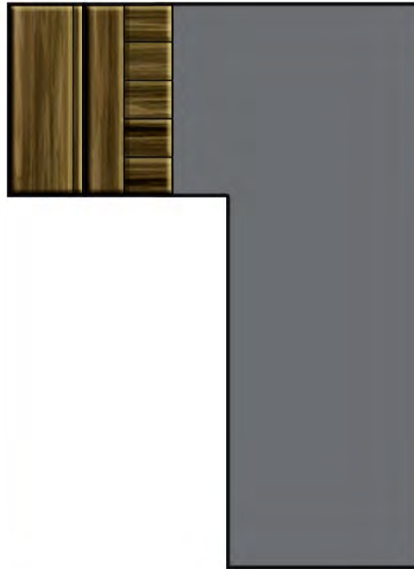
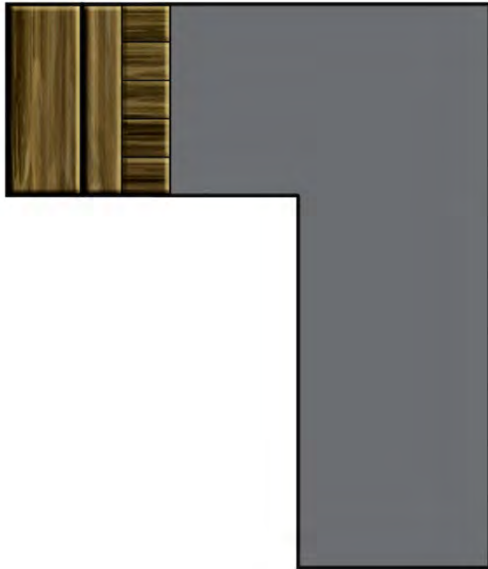
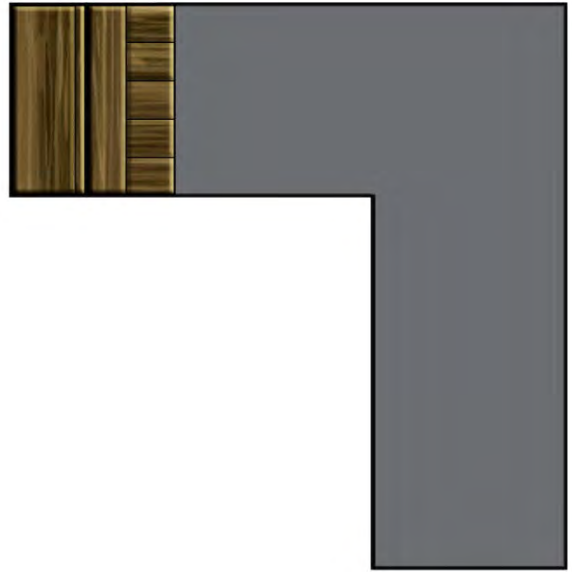

### Railings

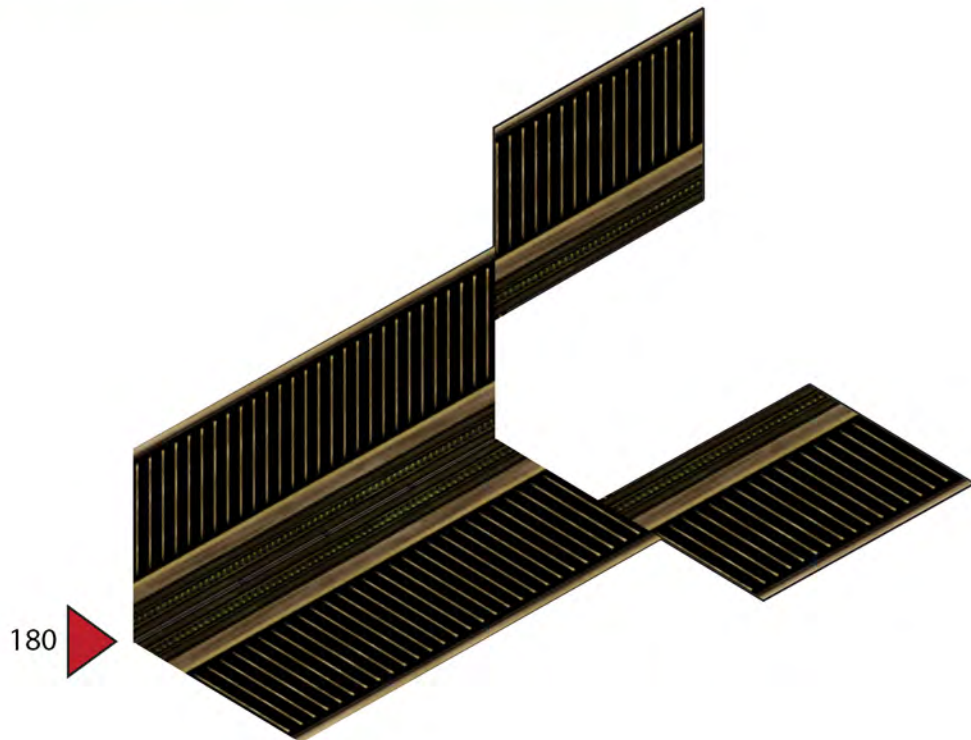
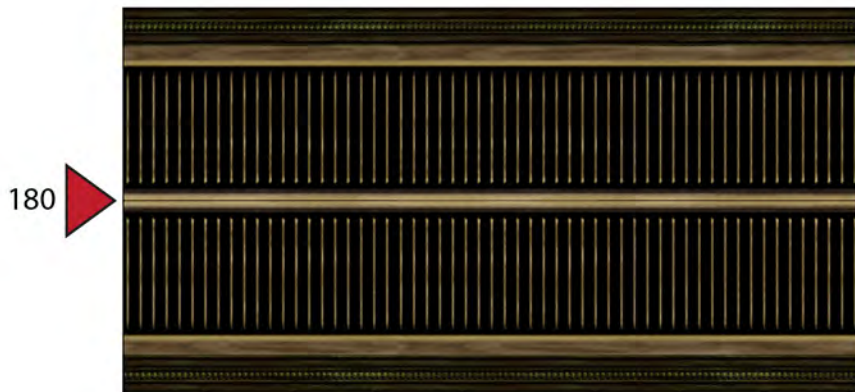
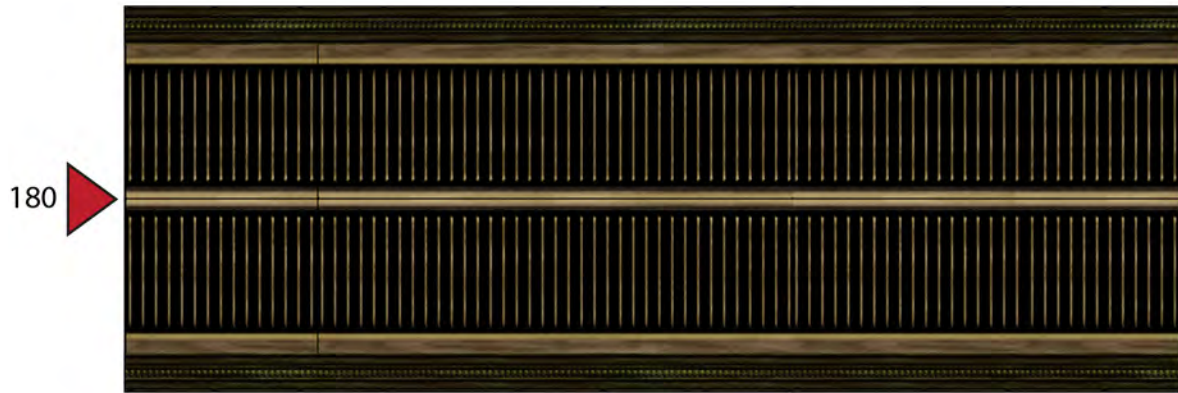



\

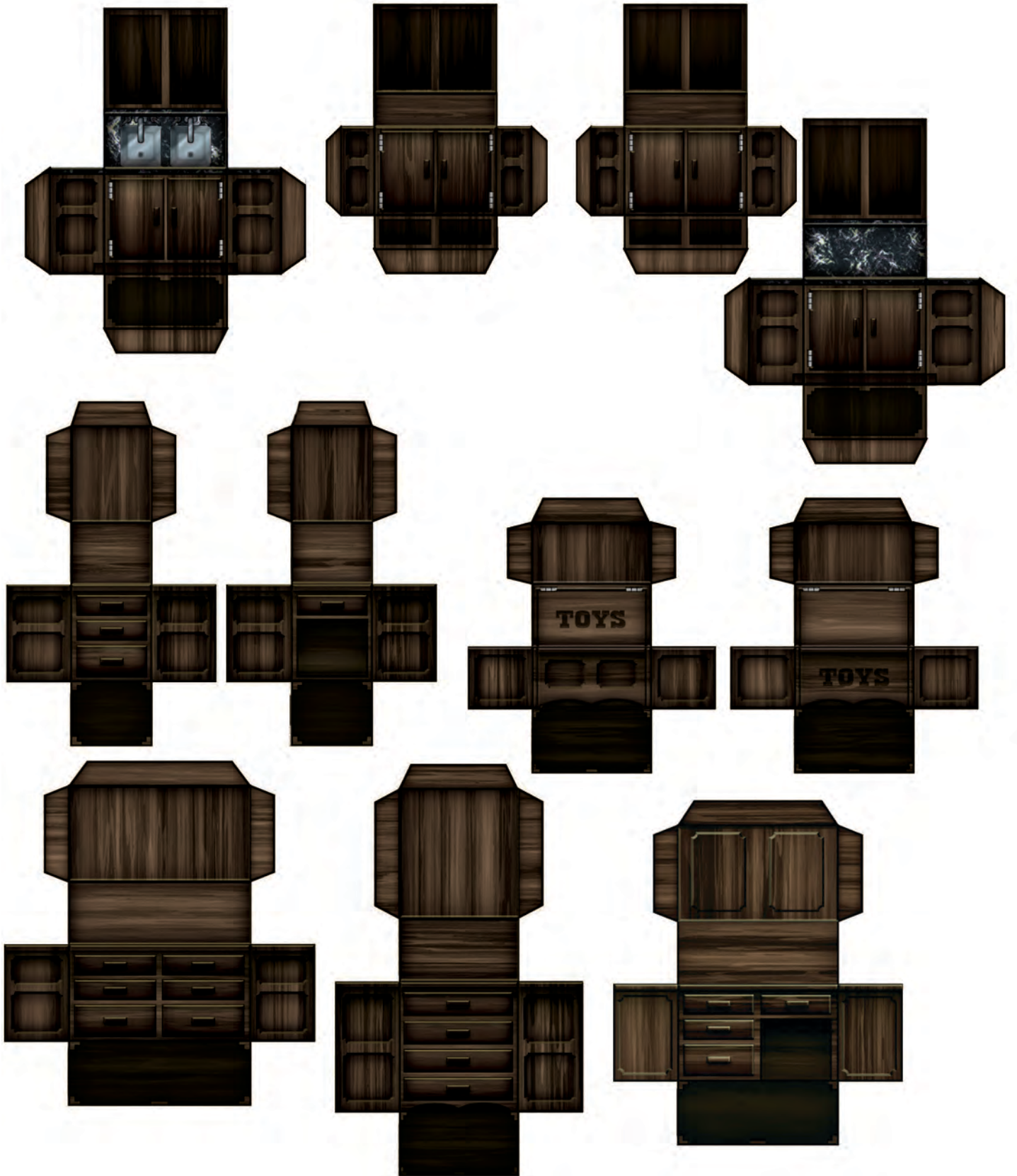



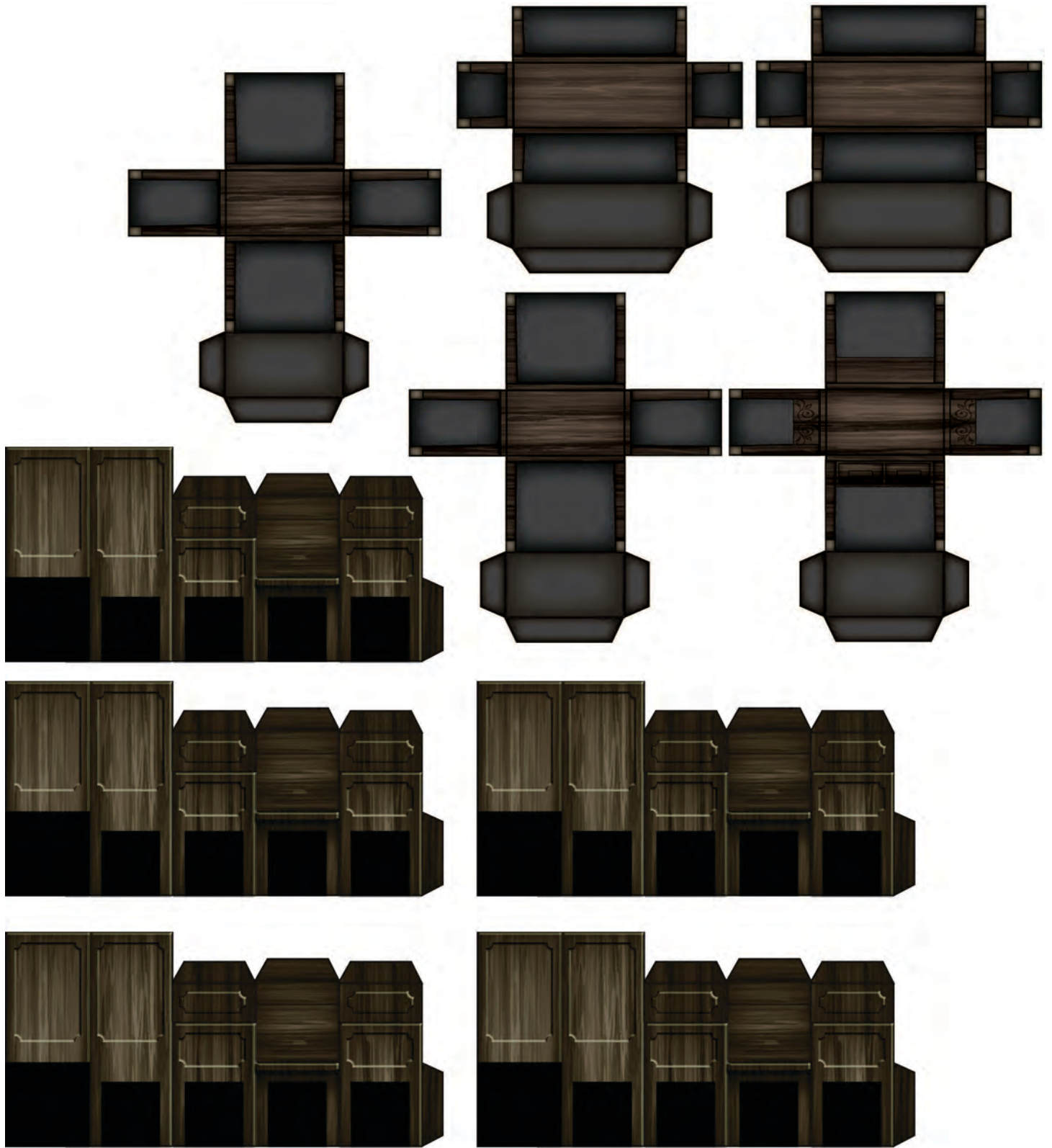

Television set (less than modern tech)

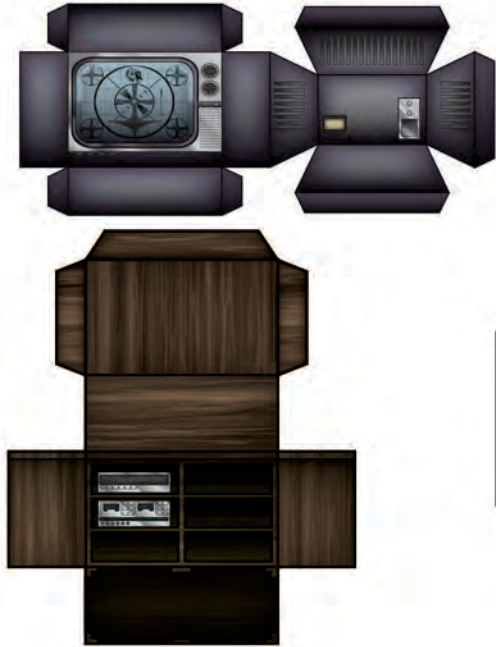

Washing machine



Alternate Stove

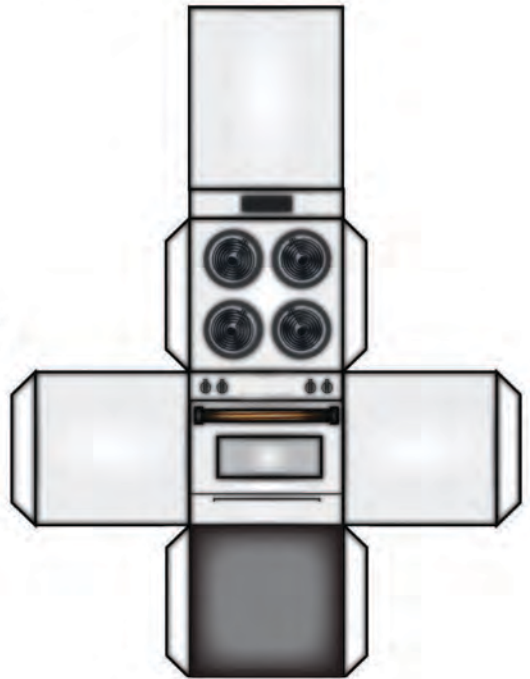

Piano

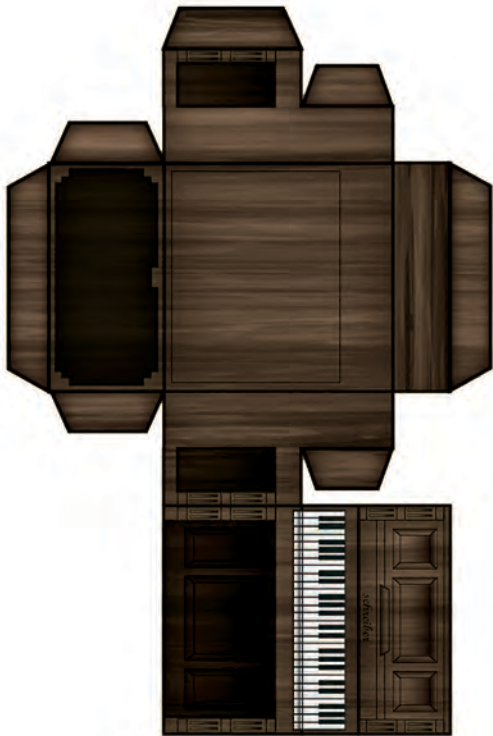

Simple bath tub

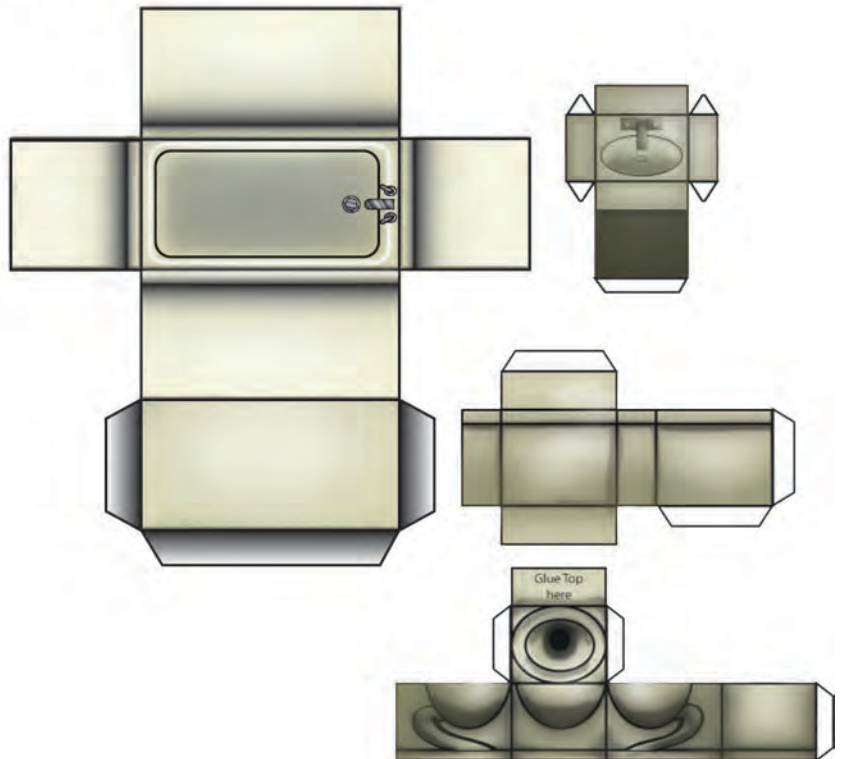



Lower floor chimney part.

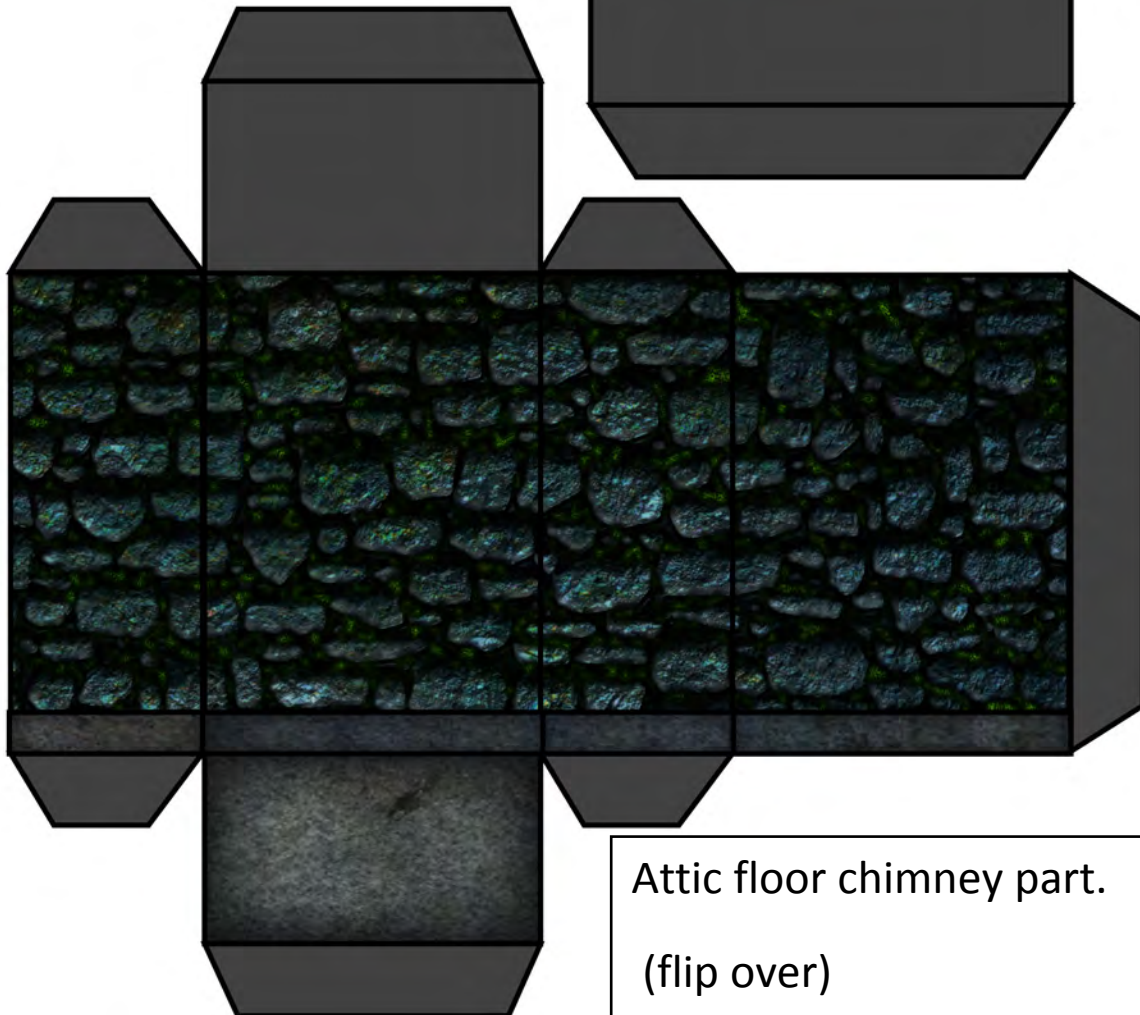
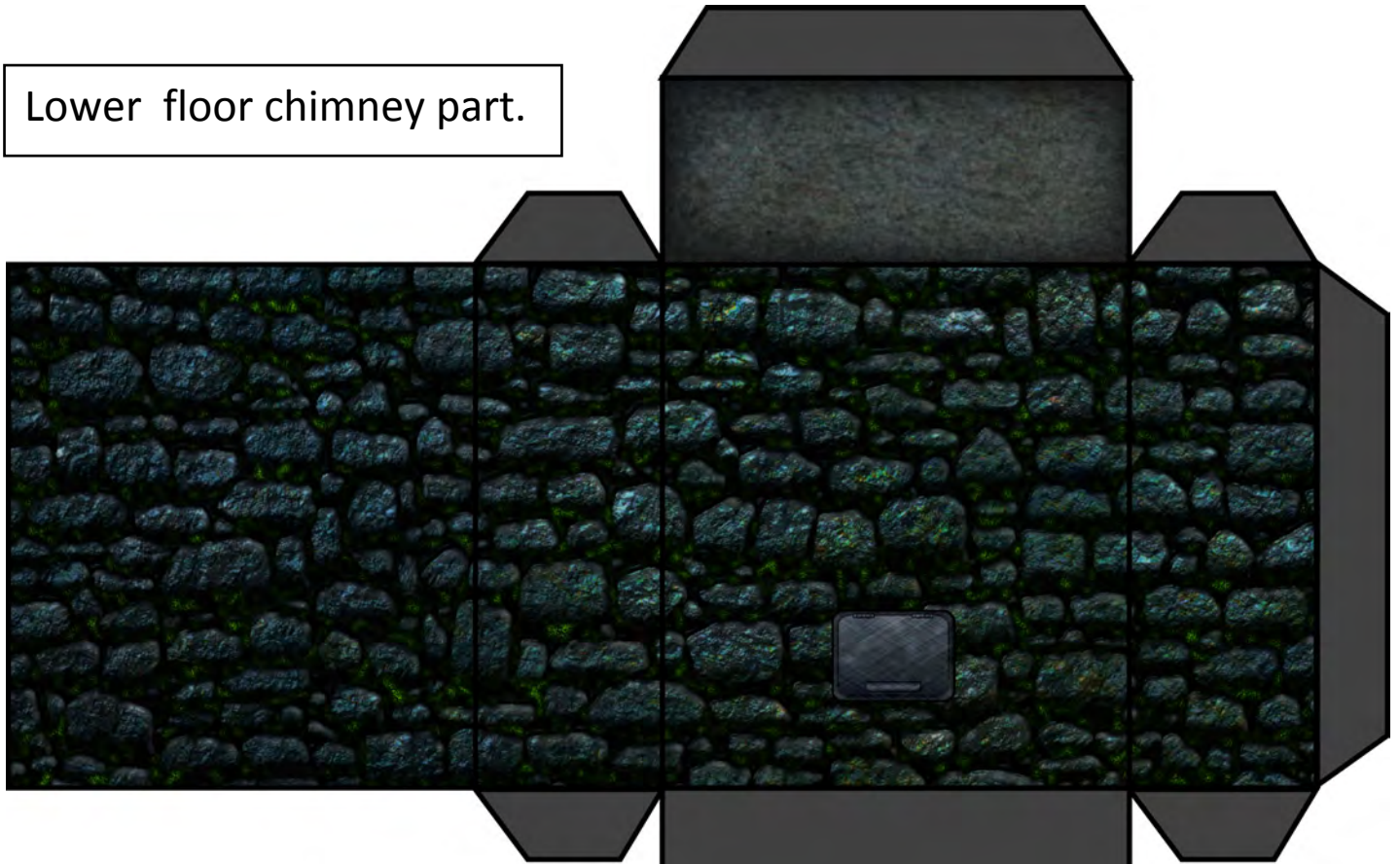

Attic floor chimney part.  
(flip over)

2nd floor chimney part.

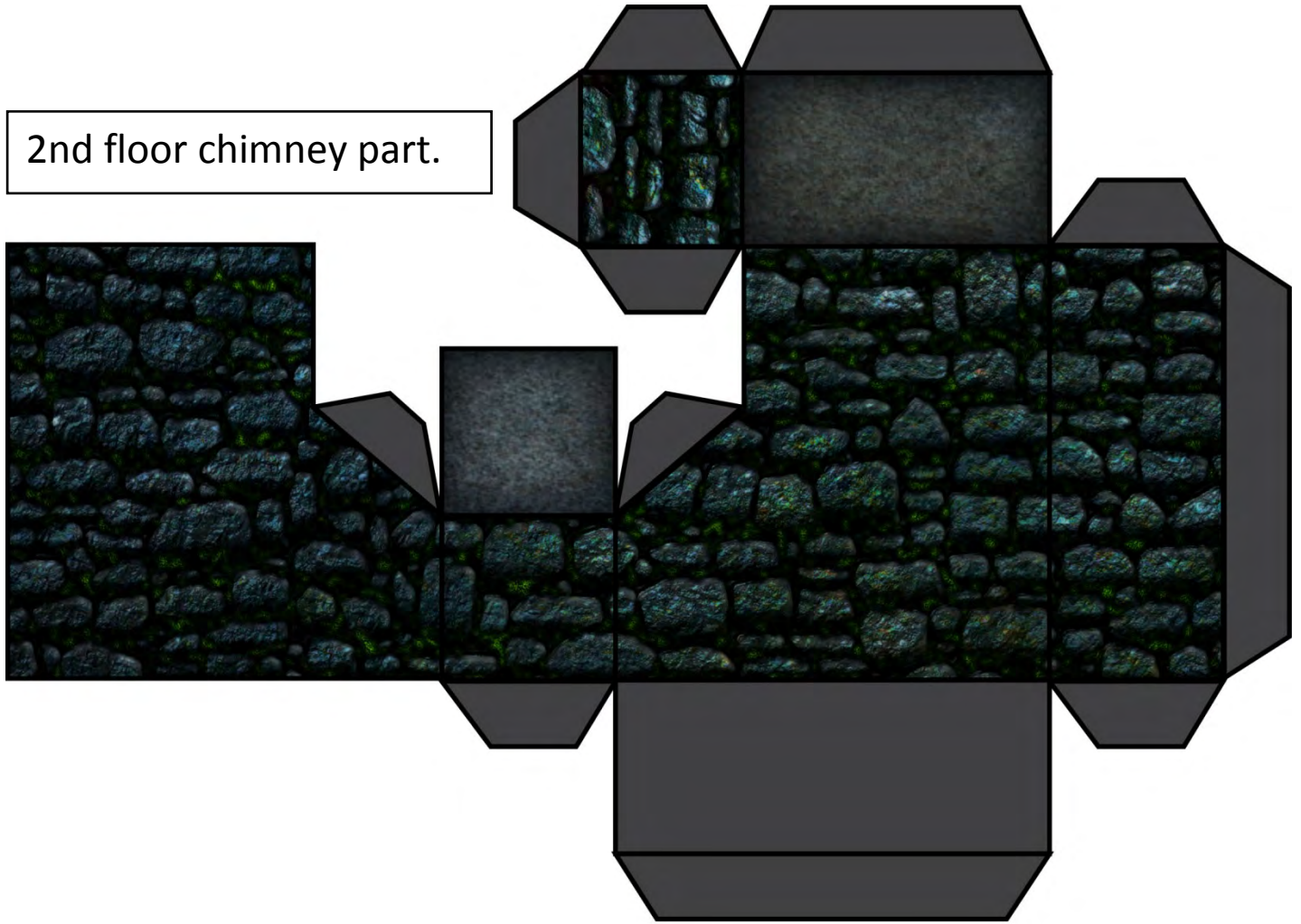

Interior fireplace



Corner wrappers



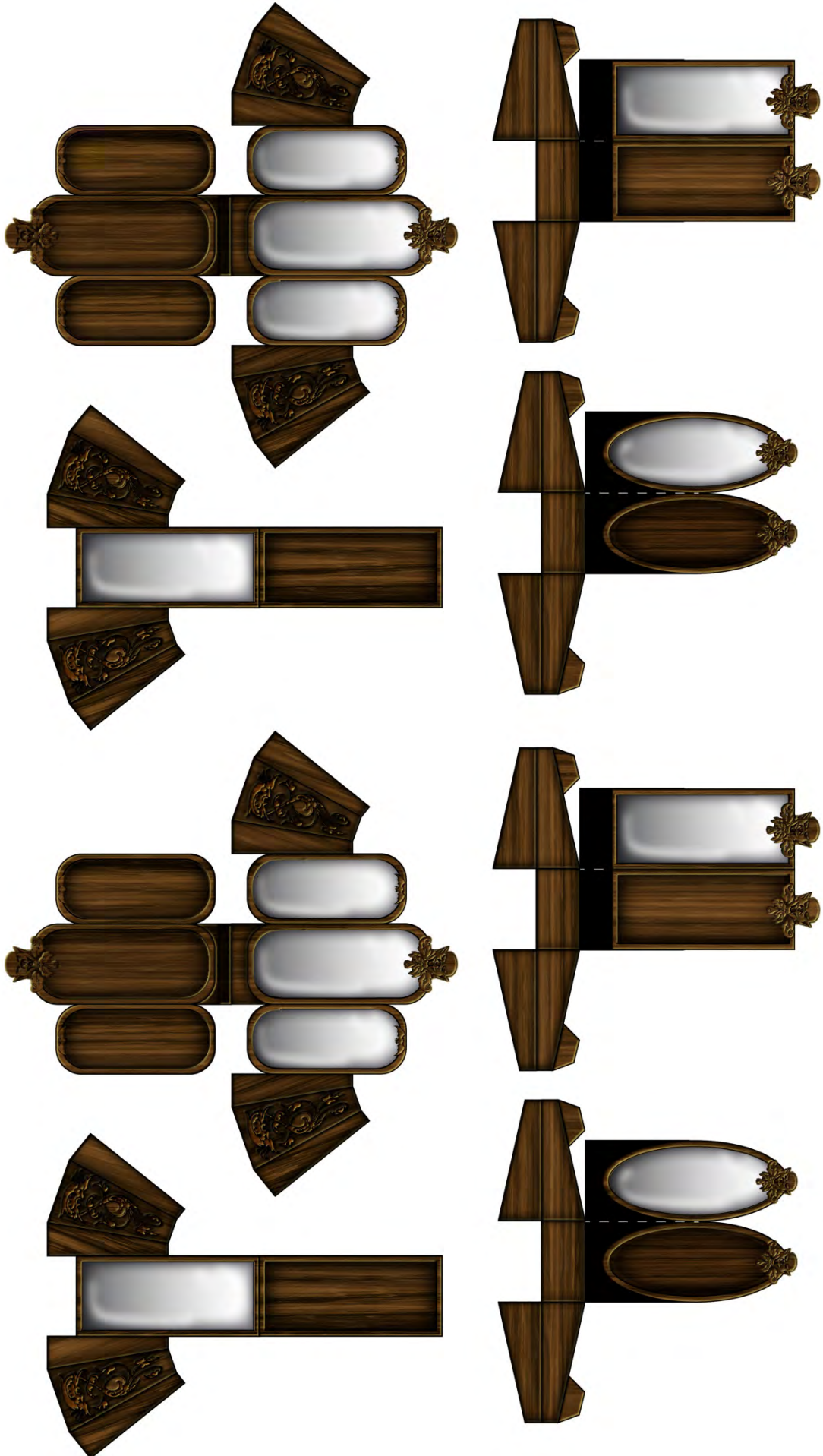





Chairs

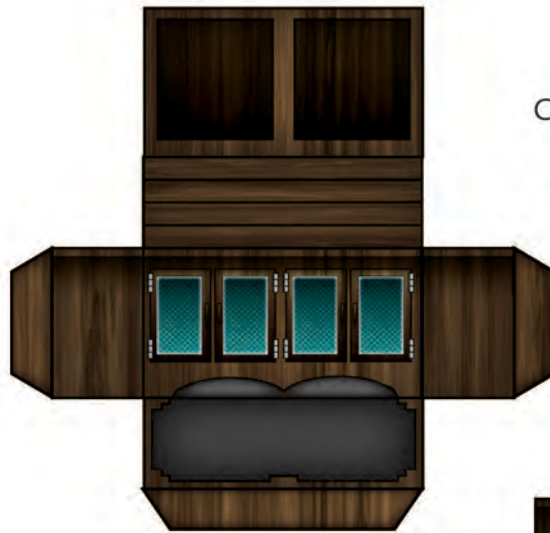
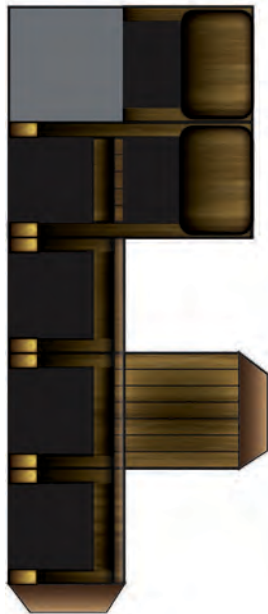

China Cabinet

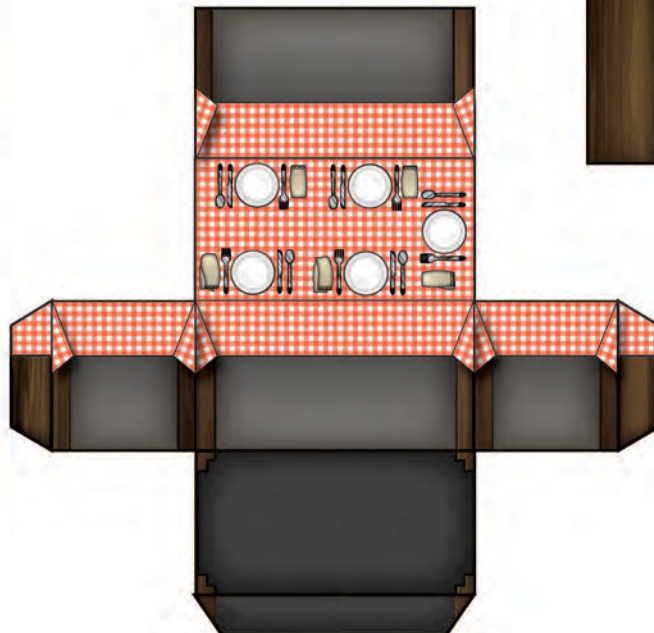

Taller beds

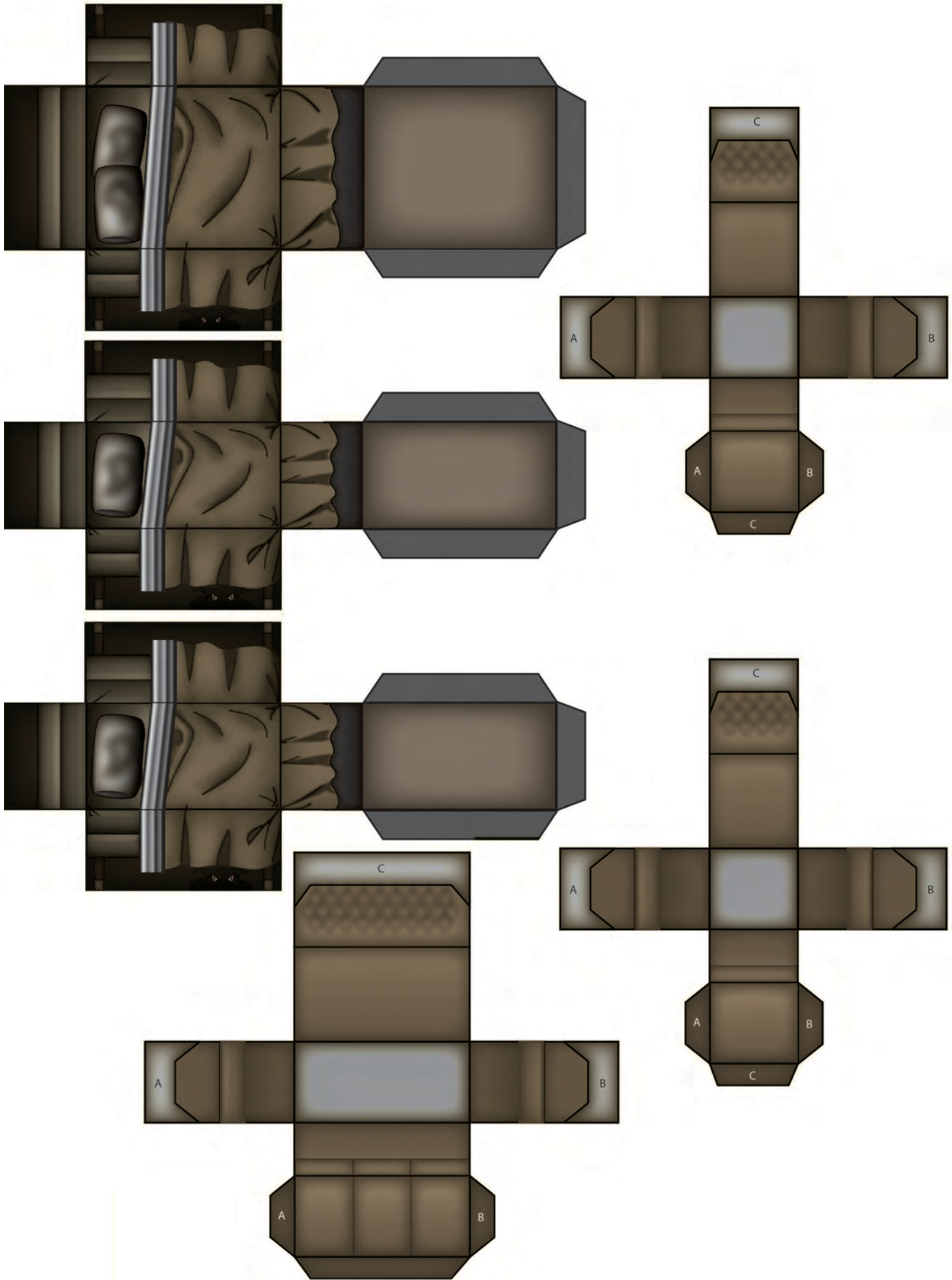

Let there be light

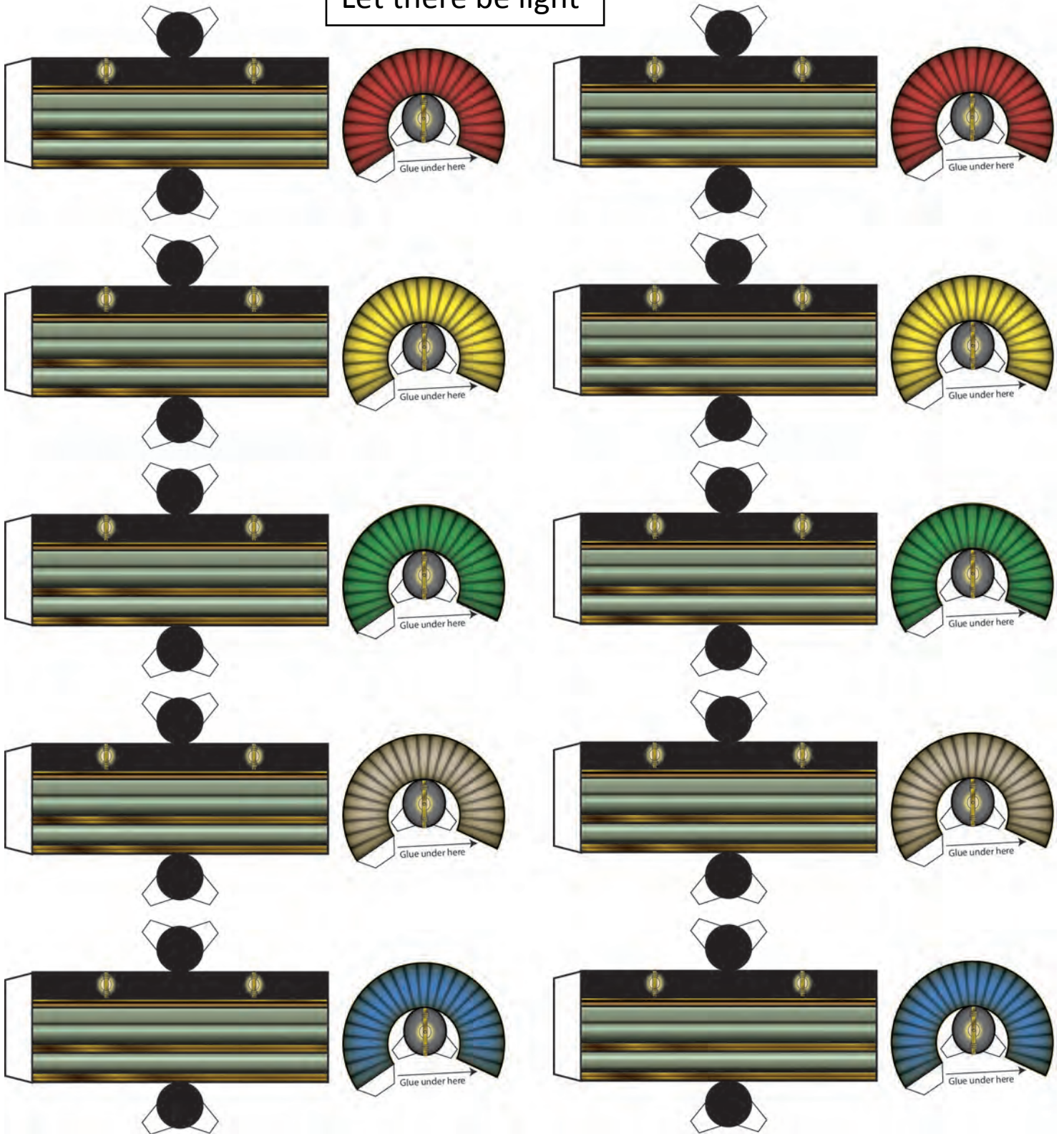

Windows and Doors

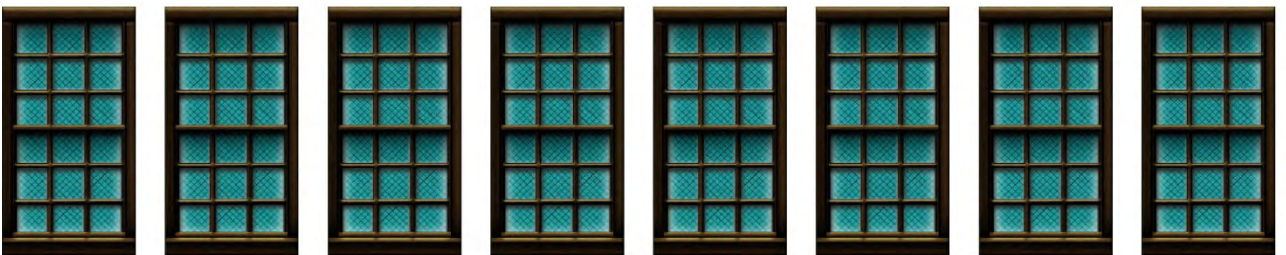
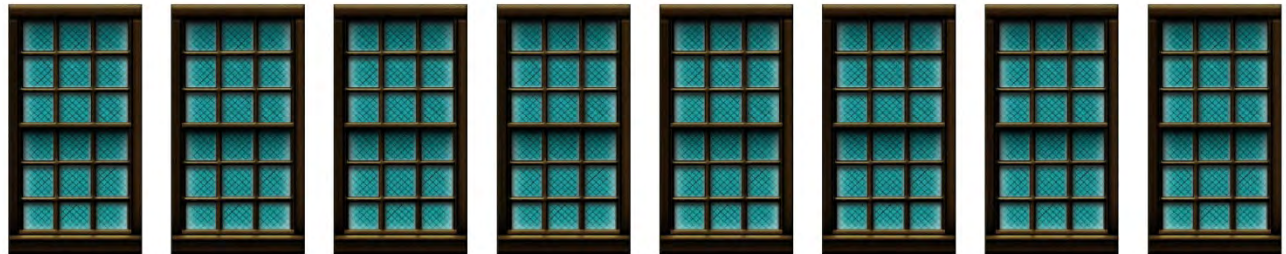
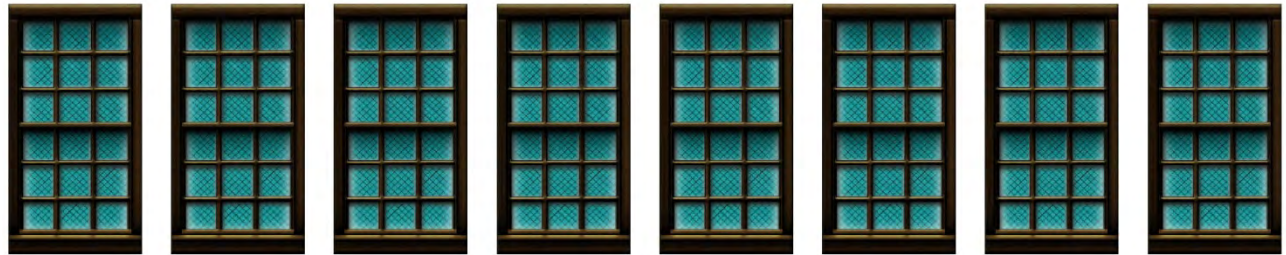

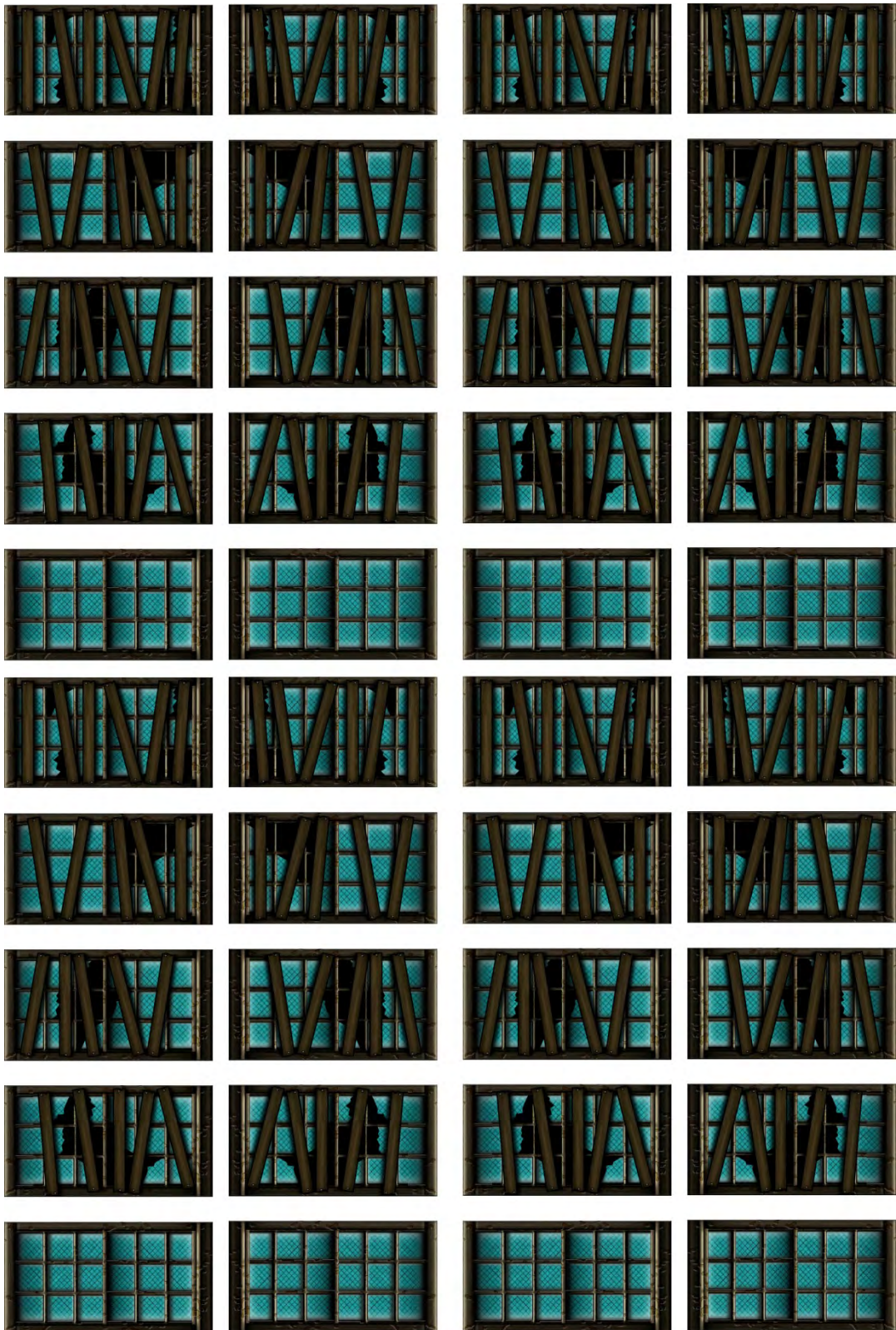

# **Alternate walls**

**For those who do not want to use sliding secret doors, or switchable paintings. Simply replace the following wall sections out for those provided earlier. Mount these front and back, skip the whole template business.**

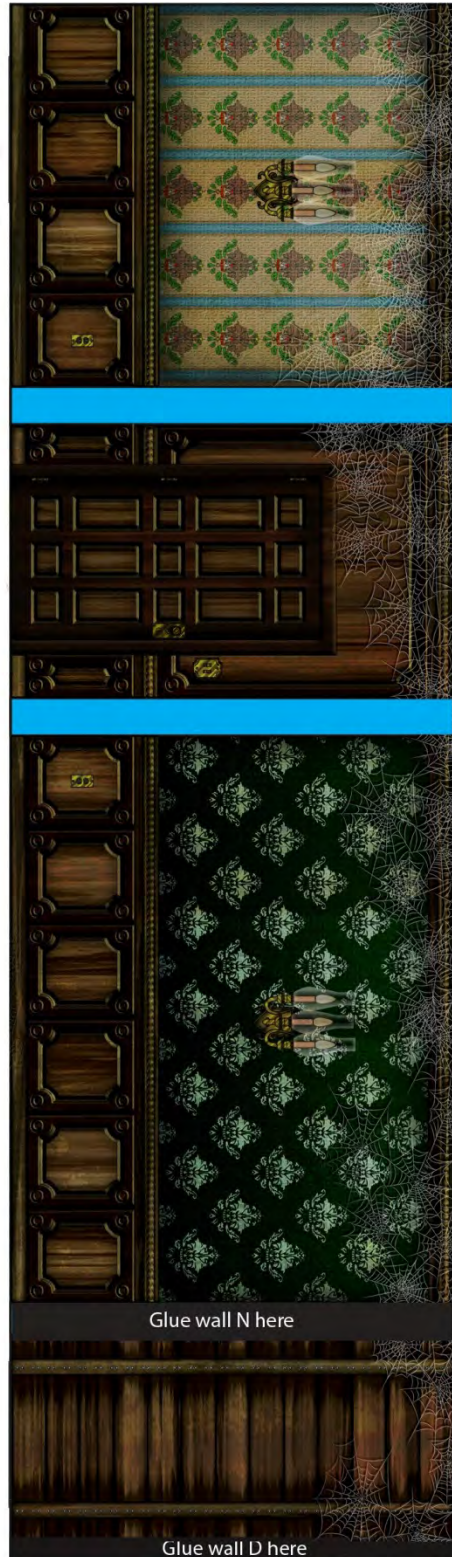

**K**  
Exterior