



**For 3-6 players.**

**Suitable for players who are old enough to cuss around  
their parents.**

*For Dustin, Robert, Kevin, Anthony, Linus, Bo, Cindy, mom, dad, all Seven Sickles and all the Failures too. You all told me I could and if I had never heard those words I probably wouldn't have.*

*For Colton, Lucas, and the rest. You told me I couldn't. You may now form a single file line and blow me.*

Canted Comic font provided by Nils Cordes. Cuyabra Font provided by Nestor Delgado. Impacted font provided by Harrison Reilly

Illustrations provided by Loel Fortugaleza, Dimvitaris, Raggedy, Popiell, Curry-Kohai, Daniel woods, Atryl, and Vincentius Matthew.

Significant editorial contributions by Rasmus Lund, Zach Loman, Kevin Garza, David Carhart, Amy Hornbaker, Andrew Charlton, Dustin Broadhead, Micah Still, Derek Hurst, Andrew Adkins, Alex Patrick, and Nathan Lawson.

*Copyright 2018 Harry Black. Please do not steal this book.  
We know it is in the spirit of the game if you do, but still.*

## USING THIS BOOK: HOW AND WHY

You will find, contained within this book, the complete instructions to *Toonpunk: A Cyberpunk Heist Game for the Whole \$@#%! Family*.

This book will serve not only as an essential primer for first-time players, but a handy reference guide for veterans. This book should be shared between players of the game as needed, and within you will find definitions of all terminology used in this game, and an explanation of how it all functions together.

This book should be used only as a reference guide, and not as a paperweight, a bludgeon, or a doorstop: it is too large for the first, and too small for the latter two.

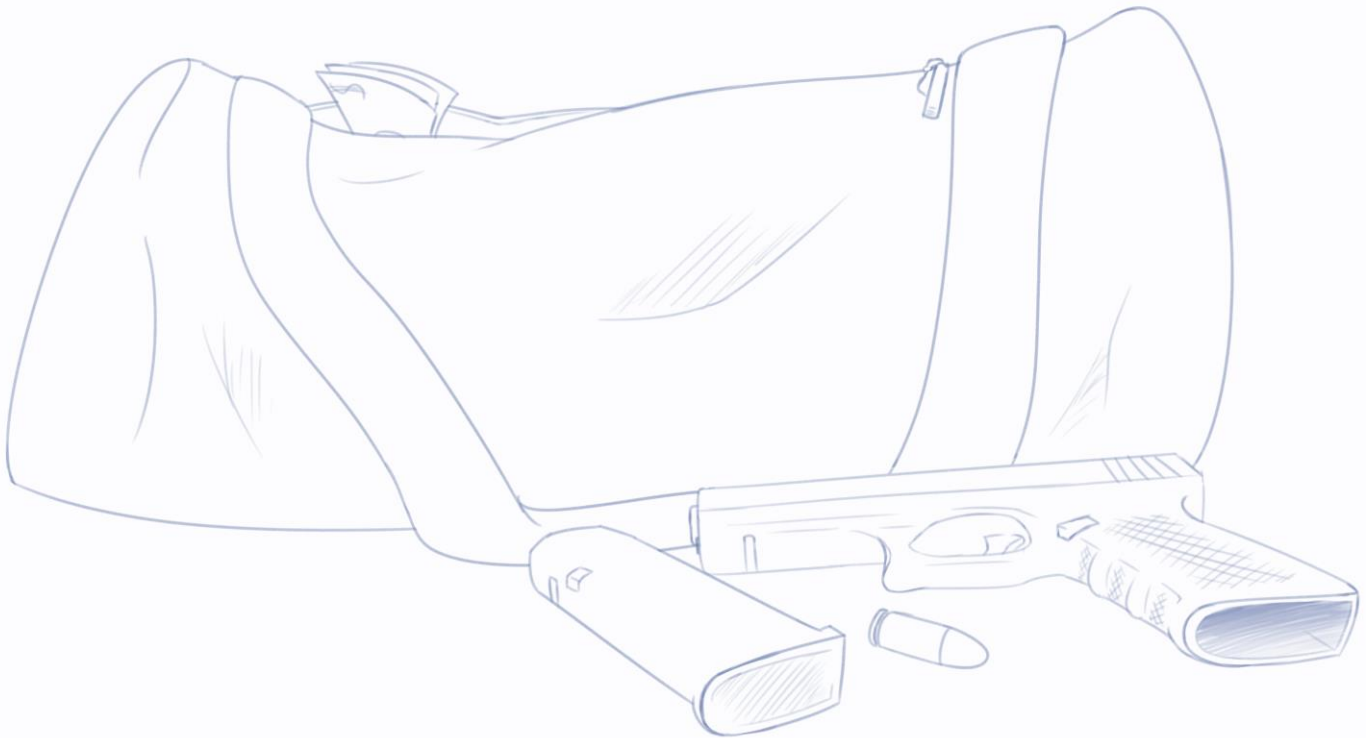

# Table of Contents

<b>Introduction: What is Toonpunk?</b> .....	<b>1</b>
<b>Rules of the Game</b> .....	<b>2</b>
Understanding the Game I: What You Need to Get Started.....	2
Understanding the Game II: Characters and the GM.....	2
Understanding the Game III: Getting into Character .....	3
Playing the Game I: Encounters .....	4
Playing the Game II: Jobs and the Map .....	5
A Bit of Vocabulary: Toonpunk Slang for Beginners .....	5
Playing the Game III: Reading the Map and Map Stuff.....	6
Playing the Game III.V: Security Measures. Both of Them. ....	9
Playing the Game IV: Skills .....	10
Playing the Game V: Rolling and Power Bursts.....	11
Penalties: Your Biggest Issue.....	11
When Do You Roll? .....	11
Power Bursts.....	12
Mixing Math: The Golden Rule .....	12
Rounding Numbers.....	12
Close Enough: If the GM Gets Bored.....	12
What the Hell?! Things This Book Doesn't Adequately Explain .....	12
Playing the Game VI: Buying Stuff .....	13
Playing the Game VII: Turn Order and Taking Your Turn.....	13
<b>Character Condition: Dealing and Taking Damage</b> .....	<b>14</b>
Character Condition I: Health.....	14
Character Condition II: Incapacitation and Death.....	14
Surrendering and Getting Tied Up.....	14
Carrying the Dead and Dying .....	15
Miraculous Recovery .....	15
Character Condition III: Damage and Barriers .....	15
Character Condition IV: Remaining Incognito .....	16
Reputation I: Infamy .....	17
Good Things About Infamy:.....	17
Bad Things About Infamy:.....	17
How to Get Infamous:.....	17
How to Get Anonymous:.....	17
<b>Acting I: All you Need to Know</b> .....	<b>18</b>
<b>Combat: Things You Must Understand in Order to be an Effective Brute or Gunman</b> .....	<b>19</b>
When Should You Resort to Combat? .....	19
Combat I: Item Characteristics.....	19
Doodles.....	20
Ammunition .....	20
Combat II: Line of Sight and Cover.....	21
Peeking.....	21
Combat III: Using and Loading Weapons.....	21
Alerting Enemies: Silenced and Suppressed Weapons.....	21
Ammunition: Shooting and Reloading.....	22
Targeting: Multishot and Multitarget.....	22
Weapon Range: Effective and Maximum.....	22
Weapon Switch: Equipping and Swapping .....	22
Combat IV: Clashing and Evading.....	22
Clash Success and Damage Tables .....	23
Clash Damage Table: Lethal.....	23
Clash Damage Table: Nonlethal .....	23
Combat V: Critical Rolls.....	24
Combat VI: Combat Actions .....	25
Combat VII: Weapon Traits .....	27
<b>Sneaking: What you Need to be an Assassin or Second Story Man</b> .....	<b>32</b>
Sneaking I: Taking Turns While Sneaking.....	32
Sneaking II: Scrutiny and Senses.....	32
Sneaking III: Stances and Distraction.....	32
Sneaking III: Sneak Attacks .....	33
Sneaking IV: Sneaking and Combat.....	33
<b>Hacking: How to Conquer Computers and Twist Technology</b> ..	<b>34</b>
Hacking I: Overview.....	34
Hacking II: Objects and Hacking Clashes .....	34
Hacking In Stealth .....	35
Hacking III: Executables .....	35
Hacking IV: Things You Can Hack .....	35
<b>Character Creation</b> .....	<b>37</b>
Character Creation I: The Idea.....	37
Character Creation II: Character Attributes.....	38
Specialties .....	39
Character Creation III: What are you?.....	40
Character Creation IV: Character Inventory.....	42
Inventory Addendum: Well I Guess it Could Be .....	42
Character Creation V: Augmentation.....	43
<b>Running the Game: How to be a GM Who Is Real Good</b> .....	<b>44</b>
Preparing a Game I: Things Which You Ought to Note and Track .....	44
Preparing a Game II: Maps .....	44
Preparing a Game III: Population.....	45
Preparing a Game IV: The Police .....	46
Preparing a Game V: How to Prepare a Campaign .....	47
Preparing a Game VI: Tips for Assembling a Story .....	47
Preparing a Game VII: House Rules and Touching Base.....	48
Preparing a Game VIII: How to Set Up a Game .....	49
Preparing a Game IX: Interacting With Your Players.....	49
I Don't Trust Him! .....	49
Dave, Don't Do That.....	50
Let's Split up!.....	50

Improvising Dialogue .....	50
Improvising a Story .....	50
Improvising Everything Else .....	51

**The Black Market ..... 53**

Entry Level Equipment: For Those Who Are Not Long For This Earth .....	53
Basic Equipment: Low Rent Tools for the Amateur Operator ..	53
Good Guns: Balanced Ballistics for an Experienced Operator ...	55
Getting Sassy: Silent Arms for Secret Agents .....	56
Overcompensating: Shotguns, Machine Guns, Launchers .....	58
One Shot, One Kill: Sniper Rifles, Nothing But.....	61
Swords and Boards: And Tasers, and Spears, and Other Stuff Too .....	62
Special Guns for Special Moments: Mediguns, Lasers, Holdout Guns.....	64
Doodles: Gags and Graffiti .....	67
Stayin Alive: Armor For Your Body .....	72
Functional Fashion: Stuff you Wear that Isn't Body Armor.....	75
The Other Kind of Hardware: Tools, Wires, and All That Jazz....	77
Calculators and Computers.....	80
The Neer-Do-Well's Necessities: Tools For Con Men, and Their ilk.....	82
Surgical Supplies .....	84
Drugs: Rock Cocaine. It isn't glamorous, or cool, or kid stuff..	85
Mastermind's Menagerie: Plans, Schemes, and Inside Men .....	85
BOMBS! And some Grenades Too .....	87
Weapon Modifications.....	89
Alternate Ammunition.....	92
Augmentation of all Distinction .....	94
Global Augments: Put em Everywhere! .....	94
Special Augments: Put Em Elsewhere! .....	94
Skull Augments: Skullcaps and Skullguns .....	95
Neck Augments: Rubbernecks, Roughnecks.....	97
Chest Augments: Not That Kind .....	98
Back Augments: Not Just Braces.....	99
Mechanics: They Get Their Own Section .....	100
Arm Augments: Longarms, Strongarms, TimetoGetTheFrictionOnArms .....	101
Waist Augments: Waists Of Time, Money.....	103
Leg Augments: The Stuff of Leg Ends.....	104
Life Lessons: Something to Make you Better Than you Were	105

**Appendices: Examples, Mostly. .... 106**

Example Gameplay: What Happens in a Typical Game?.....	106
Templates I: Sample Statlines and Loadouts for Player Characters.....	114
Templates II: Sample Enemies, Both Weak and Strong.....	119
½ Point Enemies: Low-Level Goons You Can Beat Up Easy	119
1 Point Enemies: Use a Little Caution for These.....	120

2 Point Enemies: Get Ready to Break a Sweat! .....	123
The Doublearth at a Glance: Ideas for Your Own Stories .....	125

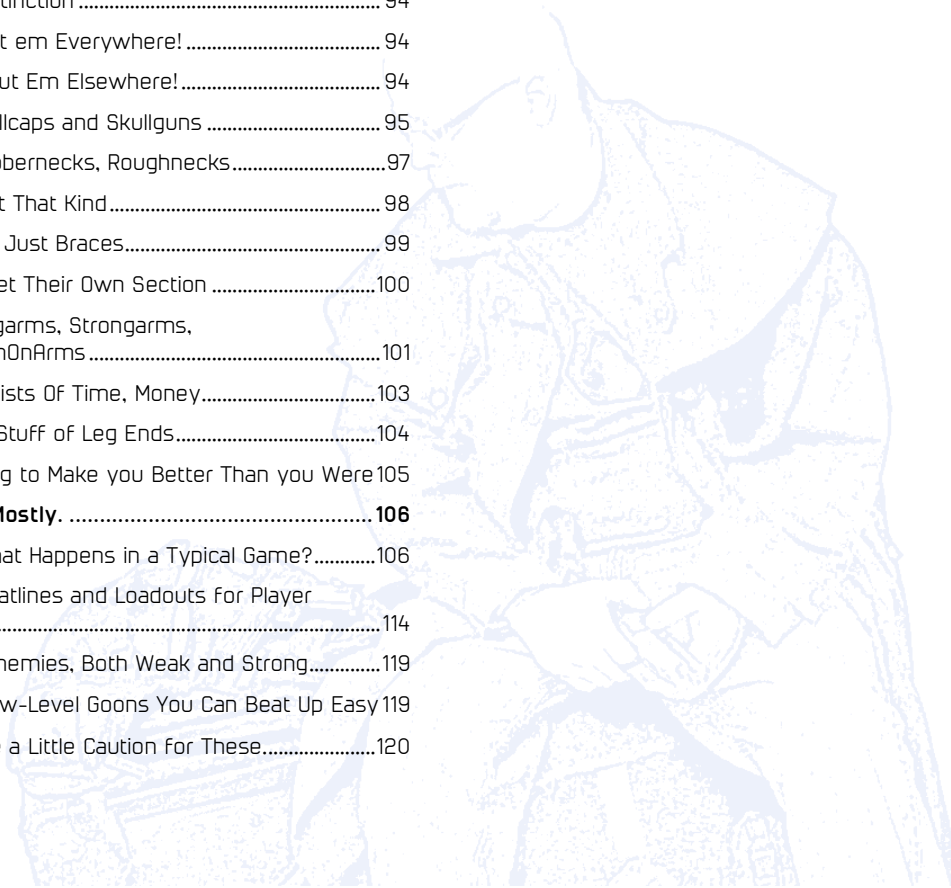

## Introduction: What is Toonpunk?

Toonpunk—abbreviated in this manual as TP—is a board game. More specifically than that, it is a role-playing game. If you are unfamiliar with the term, think of a role-playing game as a playground game of pretend with rules—the kind of rules that make sure nobody has an everything-proof shield, and that everyone is *just* vulnerable enough to keep things interesting. All the players take on and act out the parts of characters that they create. It's like a stage play—except there is no script, and the things you do can change how the story unfolds; and the rules of the game are used to govern your success. They give you ways to achieve your goals in a way that everyone else can agree is fair. One player is the “Game Master”. They provide a setting, adversity and, adventure—they control the world around the other players and interpret the rulebook as necessary. It is their job to make sure everyone has a good time—it's difficult, but rewarding.

Toonpunk, as a game, is designed to provide a stimulating and enjoyable experience that is approachable for inexperienced players, but has enough complex interlocking parts to keep you interested even after you've been playing it for years. Its rules are designed to simulate the workings of criminal enterprise in a cyberpunk setting, with a wacky cartoon twist. It marries the elaborate high-stakes villainy of Hollywood crime capers with the comedic leanings and colorful plots of golden-age cartoons, and flavors them both with far-future technology and science.

Toonpunk contains rules for computer hacking, infantry combat at all ranges, and stealthy ninja-like infiltration. Each of these rules can be used in concert with any other, to create an exciting and complex adventure; but more than that, each aspect of Toonpunk is designed to be simple and memorable, to ensure that playing the game is fast, easy, and fun.

In a game of Toonpunk, you might break out of a prison spaceship using a portable hole, or kidnap the cybernetically-enhanced CEO of a multinational corporation by stuffing him into the trunk of a talking Hearse. This game is not in any way realistic, or sensible, or down-to-earth; but nowhere else will you find Toonpunk's unique mix of science fiction, cartoon slapstick, and meticulously-crafted rapid-paced multi-faceted gameplay. To pare it down to the bullet points:

- Toonpunk is a **Tactical** game. This manual has been made to create a tightly-focused and well-defined experience, with little ambiguity. Letting random chance govern the proceedings is strongly discouraged: ideally, the players' success or failure will come because of their mastery of the rules in this book.
- Toonpunk is a game about **specializing**. Players are given a limited number of skill points and funds to allocate. Players must pick and choose their skills and gear. A character who attempts to be good at everything will wind up being good at nothing.
- Toonpunk is a **Stylized** game. The rules included in this book are not meant to realistically capture the precise mechanics of ballistics, electronics, sneaking, or anything else. The mechanics provided here are as deep as they must be in order to create an engaging experience, but the minutiae and vagaries of the subject matter are largely glossed over for simplicity's sake.
- Toonpunk is a game without a pre-existing narrative. Many tabletop games of this nature often include swathes of fiction in their manuals, to contextualize the material within. Toonpunk maintains its own setting—called the Doubleearth—but no additional material needs to be read to understand the rules of this game. We believe that much of the fun of a game like this is creating your own story and world to go with it. There is a perfunctory arrangement of world and setting details included at the end of this manual, with more detailed information available on **Toonpunk-game.com**; but these are intended only to provide inspiration for games of your own, and may be easily ignored if you have your own story in mind.

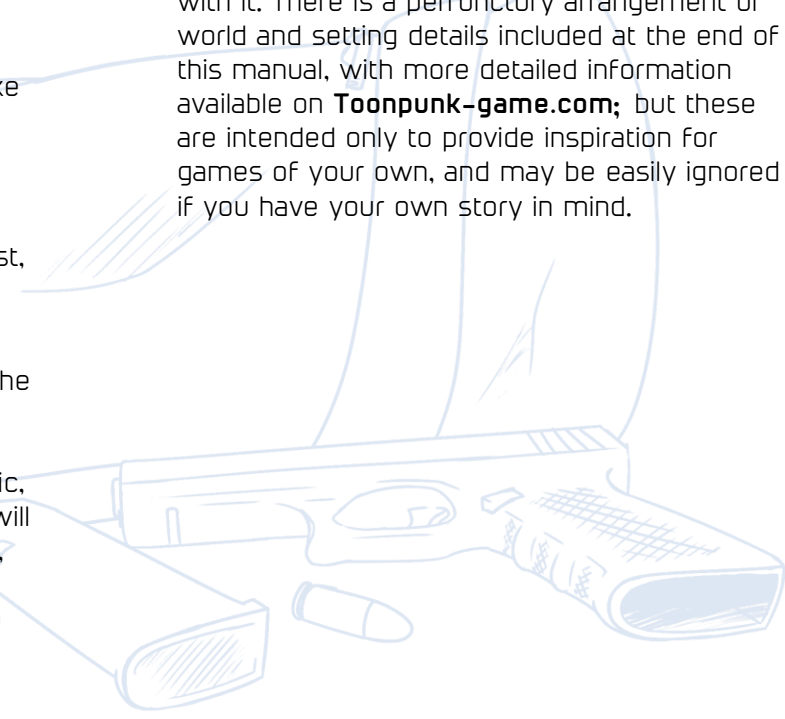

# Rules of the Game

## Understanding the Game I: What You Need to Get Started

There is a small degree of material preparation required before you can play a game of Toonpunk. Most of the things you need can be acquired at an affordable price from your local arts and crafts or tabletop game store; and the rest can be acquired at Toonpunk-Game.com. These are as follows:

**This Book:** Done. Good job.

**A Place to Play the Game:** A reasonably large table—at least large enough to seat four easily, and six with a bit of work. In the absence of a table, a floor will do so long as you make sure nobody walks over the playing area.

**Character Sheets:** Sheets of paper on which players and the GM can record the abilities, equipment, and finances of players and enemies. A photocopyable character sheet template can be found at the back of this book; and additionally, there are many completed enemy templates available for your use at **Toonpunk-Game.com**.

**Tokens:** Miniatures, cardboard pieces, or miscellaneous bric-a-brac which can be used to represent the players, enemies, and other assorted NPC characters. Building blocks, marbles, and other such sundry items may suffice in a pinch.

**Dice:** Ten-sided, six-sided, and four-sided. These can be acquired by themselves or in bulk. Bring spares in case any fall off the table or underneath any other furniture.

**Maps:** Clearly-drawn maps which may be used to represent the various spaces the players will move through. There are many completed maps available for use at **Toonpunk-Game.com**; or if you are confident in your abilities, there are instructions for making your own maps later on in this manual.

**Spare Pencils and Paper:** On which the players and the GM both can record other information of importance—perhaps strategies, infiltration routes, or other notes which might not fit anywhere else.

## Understanding the Game II: Characters and the GM

At the heart of any TP game is its characters: the debatably -moral and definitely-unethical vessels through which the players interact with the world and the stories within. Playing a character in TP is much like writing a character in a book or TV show: you control their actions, thoughts, and emotions; and you interact with other players and their characters. There can be six, ten, or even more players just like you, who will work with you or against you in the pursuit of power and profit. In addition to them, though, there is another player, who is known as the Game Master, or GM.

The GM is a combination storyteller and antagonist: he creates and describes the challenges your characters face, and the world they are presented with. The GM plays the part of the enemies and civilians you encounter—in essence, the GM controls everything except your character, and the characters of other players.

**The GM has Carte Blanche on everything except player characters' thoughts and actions.** This applies for everything in this book. **What the GM says, goes:** in their capacity as a referee they can dismiss, instate, or modify anything in this book as they see fit, for the convenience of all.

Even though the GM is the antagonist in the game, remember that they are your friend, and that it is their job to provide a fun time for everyone. **If the GM ever decides that you are enemies** on any level *other* than one that's fun and imaginary, **something is going wrong.** Remember not to confuse your in-character ambitions and behavior with your out-of-character relationships.

While this might sound like simple advice, many veteran role-players can attest that sometimes that is more difficult than it sounds. Communicate with other players as clearly as possible to ensure that everyone is having a good time, or else nobody will. If you feel that the GM is failing to fulfill their duty of providing a good time, address this point to them as politely as possible and attempt to reach a mutual understanding, so you can get back to having fun!

## Understanding the Game III: Getting into Character

As mentioned earlier, role-playing games are like books or movies where you control the characters; and a huge chunk of the fun is in playing out the wild and crazy adventures of a larger-than-life character! The very first thing you'll have to do to play this game is create a character. A character is a mouthpiece by which you will interact with the world of the game, and carve out your reputation as a criminal legend.

Your character, despite being gifted and trained in a wide variety of ways, is not necessarily *better* than anyone else. Because of the rules of the game, your character will have limitations: they will be good at some things, and not so good at other things. They can bleed and be hurt, and even die if you are incautious. They will be able to defeat most NPCs in combat, but you shouldn't overestimate their capabilities: going up against other players, or groups of enemies, will often get you badly injured...or worse. For the full breadth of rules concerning your character's abilities and creation, you should examine the **Character Creation** section of the manual, on **page 38**.

During games of Toonpunk, you will often be afforded the opportunity to have your character socialize, make decisions, or otherwise express themselves. During these times, you will need to **get into character**. Getting into character is what you call it when you begin to consciously consider the desires, motivations, quirks, and history of your character as things which are **distinct from your own**. There can be simple differences between you and your character, or a vast gulf of separation: maybe your character could be just like you only with a different accent; or you could play somebody with morals, philosophy, and opinions that are almost entirely unlike yours. Remember that because your character is your own creation, they can be anything you imagine so long as the GM feels like putting up with it: they can be noble, they can be savage, they can be brave or cowardly or smart or stupid—it's all up to you!

There are many different ways to get into character. One of the easiest ways is to imagine, in comprehensive detail, your character's history and upbringing: what were their formative moments, and how do they see the world? You can create a self-contained backstory for your character in the comfort of your own home; or you can collaborate with the GM or other players to create a backstory which interconnects with and reflects on the story of the campaign and the other characters'.

If you don't have the time or interest in creating a complicated history and personality for your character, it's possible to just improvise one as you play—a great deal of this game is in improvisation, so you might as well start as you mean to go on. This option is as simple as selecting a few random easily-defined personality quirks—such as 'talking like a cowboy', 'swearing a bunch' or 'being a racist'—and using them as the basis for your character, with the rest of their personality cropping up as needed for your adventures.

After you've gotten a character in your head, there are many ways to push them through the world. You may refer to your character's actions in the first person, throw your voice in a particular way, and enact their conversations with other characters word for word; or if you are shy about doing so, you could refer to your character entirely in the third person, and paint their conversations in broad and sweeping strokes that only carry across the gist of the situation. It's the difference between "I greet you with a hearty 'hello, let's knock over a liquor store!'" and "My character discusses the potential robbery with your character".

Getting into character is great fun, but not absolutely required. If you really want to, for whatever reason, you can play through a game of Toonpunk with no dialogue, expressing your character no other way than through combat and theft. You can play a blank slate with no discernible personality, interests, life, or goal; but this should only be done if you are prohibited from getting into character by time, language barriers, or the crushing social pressure of being older than 9.

## Playing the Game I: Encounters

This is not the most complex game ever made—but it is very definitely not the simplest, either.

Toonpunk games can encompass a nearly infinite variety of scenarios ranging from the silly to the serious, from the subtle to the sickening, from the alliterated to the whatever. Within a single game of Toonpunk you might do any number of these in sequence; and the sheer breadth and variety of these demands some judicious partitioning.

Games of Toonpunk are divided into **Encounters**. These are a way to separate moments of importance from one another, like chapters in a book. As simple as this may sound, it is actually critically important to keep the various scenes of games and campaigns separate: not only does this lend a tangible passage of time to the game, but it helps the GM dole out healing, ammunition, and rest periods to the characters.

Encounters can consist of anything, and should be separated from each other whenever the **mood, setting, or intention of a scene dramatically changes**: for example, if the crew goes into a night club and begins exchanging drinks and plans, that is an encounter of its own; but if a barfight suddenly erupts, or if they leave the bar to carry out their nefarious schemes elsewhere, then things would be different enough to count as a separate encounter.

The GM, alone and unilaterally, may declare that a new encounter has begun. However, there are certain events which can occur which should always, barring extreme circumstances, start a new encounter. In general, encounters can be sorted into one of three general “moods”; and a shift from one to the other should constitute a new encounter.

**Downtimes** are peaceful encounters in reasonably friendly environments where nobody is likely to openly attempt the murder or dismemberment of anyone else. These are used primarily to develop your characters’ personality, history, and rapport with one another; and also to create plans for your next caper. GMs should use plenty of downtime scenes in their campaigns because they require no effort and satisfy the players’ want for emotional engagement.

**Tension** encounters are situations where someone is doing something that could get them into trouble, but has yet to escalate. These include burglary, spying on something, running cons, and other situations which could potentially erupt into conflict. Tension is the normal way in which missions begin, and is inevitably triggered as a consequence of going somewhere you shouldn’t be. Tension ends when things resolve peacefully... or escalate.

**Action** is what happens when tension escalates. It is the inevitable outcome of someone getting harmed, or attempting to do the same to someone else. Action encounters *end* when the hostilities stop—either by mutual agreement, or by one side prevailing over the other.

You might ask yourself “What makes this distinction so important?” Well, there’s a few things that hinge on the barrier between encounters...

**Shields and IP:** Shields and Ink Points replenish every time an encounter begins—we haven’t talked about these yet, but they’re later on in this book.

**Armor:** Your character’s body armor—and believe you me, you’ll want your character to have body armor—can be repaired during downtime scenes.

**Healing:** Characters can be wounded many times and in many ways, but may only be healed once per encounter: whether they receive only a trifling amount of health from a quickly-quaffed bottle of painkillers, or a surgery from a qualified medic, you can only gain health **ONCE** per encounter.

**Reloading:** While characters can choose to reload their weapons at any time—and will usually have to, in sustained firefights—it is generally presumed for the sake of mutual convenience that all characters involved in an encounter begin it with their guns fully-loaded, regardless of how they were in the previous scene. It’s a cartoon, you don’t need to think about it too hard.

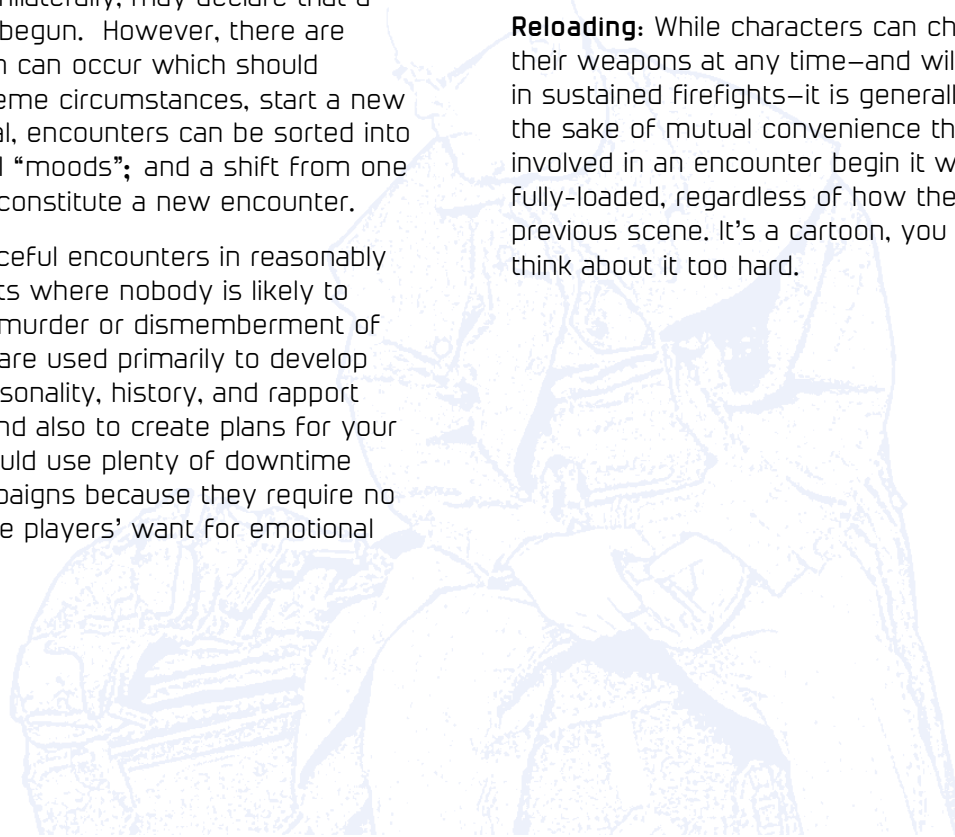



## Playing the Game II: Jobs and the Map

While the majority of your character's life is just like most other people's—with a 9-to-5 wage slave gig, a low-rent apartment, and a host of everyday issues—it's all just waiting for sundown. As a Toonpunk, your character's life is defined by what they do on the weekends and in the dead of night, when they buck the rules and assume their true identities as burgeoning masterminds. These are "Jobs"—and they are where the action happens.

A "Job" is an action encounter. It is where your characters will roll the dice and tempt fate as they sneak, hack, or fight their way to their objective. During a Job, you will be pitted against guards, security systems, and simple happenstance—all of which is dictated by the GM. Jobs come in a variety of categories, from kidnapping to assassination to theft; and the best ones allow for a vast array of approaches and outcomes. It is entirely possible for your character to die while on the job—and if you are not careful, it's very likely that they will.

During a Job, you will often roll the dice to determine your success (SEE: **Playing the Game III**). However, there is more to a job than your character's plans and abilities: the environment itself is a tangible factor, which must be observed and mastered if you are to be successful. Like many other tabletop games, the battlefields and heists of TP take place on intricately-detailed maps, which are in turn built on a simple square grid. The spaces on the grid can be filled by enemies, obstacles, friendly NPCs, players, and other objects depending on the scenario; and some of these will even fill multiple squares. There's a wide variety of terrain, objects, and hazards that can be encountered in a game of TP; and anyone who wants to succeed will familiarize themselves with as many as possible.

Each square of the grid represents approximately two square feet, except when it doesn't! It's a game about cartoons, don't think about it too hard.

## A Bit of Vocabulary: Toonpunk Slang for Beginners

**PC/NPC:** The two kinds of characters in the game. PC and NPC respectively stand for "player character" and "non-player character". A PC is a character in the game who is controlled by one of the players, and an NPC is a character controlled by the GM.

**D[X] (D10, D6, etc):** The various dice you roll. The [X] in D[X] refers to the number of sides on the die, so that a D6 is a 6 sided die, and so on and so forth.

**D5:** A kind of die not often found in nature, a D5 is sometimes called upon in Toonpunk games. Because you are very unlikely to find a D5 in the real world, the easiest way to find one is to just roll a d10 and divide the result by 2 rounding up.

**Job, Mission, Quest:** Your immediate objective, which in this game is usually robbing something. Generally used to refer to one particular crime or caper.

**Campaign:** Several jobs connected by an overarching context or series of events—such as a crime spree, or a series of assassinations. Any series of quests revolving around the same group of events or characters can be referred to as a campaign.

**Rule 0:** The commonly-repeated maxim that the GM has the ability to waive, enforce, and invent any rules they wish to, at any given point. This is generally seen as the easiest way to make sure everything keeps going smoothly. In brief, just listen to the poor guy, and trust him to do his job.

**Stats, Skills, Abilities, or Scores:** The numerical representations of your character's education and talent. These are selected at character creation and will influence you for as long as you play the game.

**Hands:** The unit of currency in the Doubleearth setting. We call them that in this manual because corporate said we had to; but you can feel free to call them credits, dollars, or whatever you want. It's your game—what are we gonna do about it?

# Playing the Game III: Reading the Map and Map Stuff

A well-designed Toonpunk map is a complicated space, with numerous different routes, terrain features, and quirks. That can be a lot to keep track of, but fortunately most important objects are color-coded for your reading convenience! Included below and on the next few pages, you will find a complete list of map elements which you will commonly encounter while playing Toonpunk, and what they mean. Study up!

## Doors, Stairs, and Map Transitions

No interior space is complete without doors: they're one of the very basic building blocks of modern architecture. Doors on the map may or may not obstruct line of sight at the GM's discretion, and characters can always move through them freely. They are represented by orange lines.



*A door.*

Similarly, some stairs, ladders, and map borders are marked with orange glows or highlights; this means that they are ways to different parts of the map, or even ways to exit the map entirely.



A safe rule of thumb to follow is that orange objects are key to moving through or altering the map in some way. These can even include secret buttons or doors which will change something about the level, so keep your eyes peeled!

## Escape Zones

Escape zones are the points at which you exit (or enter) any given map. Escape Zones are distinguished by the dotted lines surrounding them, and the orange lines crisscrossing their surface area. Any character standing in an escape zone is eligible to exit the job in its entirety, leaving allies and enemies behind. Using an escape zone does not remove the zone from the map; but they may be removed from play at the GM's discretion for other reasons. Escape zones are generally placed at the point where the players enter the map.

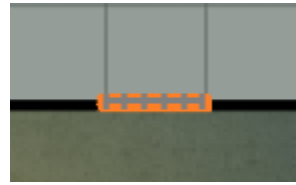

## Locked Doors

The easiest way to keep someone out of your business is to put some locks in front of it. As a criminal, you will spend a lot of time getting into people's business; and that means you will be dealing with a *lot* of locks. Locked doors are represented by large orange lines, shot through with other colors. An orange door with a grey line is locked by mechanical means, and can be opened via a hardware roll. An orange door with a blue line is locked via electronic means such as a keycard reader, and can be opened via a hacking roll. An orange door with a red line has an alarm attached to it. It can be opened with no roll, but doing so will sound an alarm that everyone on the map can hear. However, alarmed doors are always dependent upon the presence of a nearby fusebox, and can thusly be disarmed.

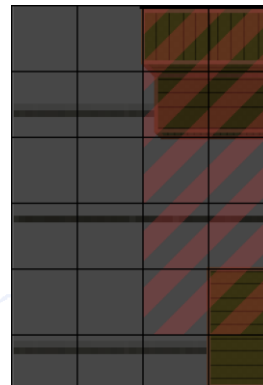
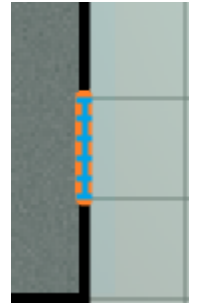

## Overhangs

Balconies, catwalks, and floating platforms: all of these are loosely referred to with the somewhat ill-fitting term "Overhang". An overhang is a part of the map which indicates the presence of a vertical element of the job—something on a higher story of the environment, which would normally require you to overlay the two maps to see. Overhangs are represented by diagonal red lines. The GM must disclose the presence of anything on the edge of an overhang to any character who can draw a line of sight to it. Characters on overhangs count as being in cover from characters below them, but not vice versa.

## Blast Doors

It's one thing to lock a door, sure. But when you absolutely, positively, no-bones-about-it-no-way-no-how want to keep anyone and everyone out of a room, you get a blast door. Blast doors are several inches (or several feet) of pure steel, operated by complex webs of hydraulics and sensors. They're just about impossible to pry open unless you have a specialized tool like a drill or a bunker-buster bomb—but lucky for you, they're usually tied to a keypad or sensor somewhere, which you can use to open it.

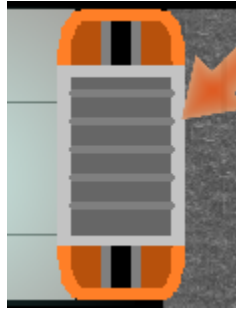

They're also spectacularly conspicuous, which can save you the trouble of having to find your target: odds are, if you want to steal, shoot, or sabotage something really important, it's behind one of these.

A blast door cannot be opened by any means except through specialized tools, or a corresponding computer console or fusebox.



## Fuseboxes

In a world where just about everything seems to be geared against you, a fusebox can be a welcome sight. It's exactly what it sounds like: a wall-mounted box of fuses, wires, gears, levers, switches, and a whole bunch of other stuff. Fuseboxes are integral parts of most low-tech electronic systems—they can govern lights, doors, cameras, and more. While you are standing adjacent to a fusebox, the GM must disclose anything dependent on its presence, such as cameras, blast doors, or alarms. You can then make a hardware roll to de-activate any number of systems attached to it. You may also sabotage them in other ways, at the GM's discretion—perhaps by turning them against their owners, if you're feeling vindictive.

## Windows

Windows are a common sight, and can be valuable assets when used right. Windows are represented by blue lines, and do not obstruct line of sight. During games, you can move through them at no additional action cost, but you will take 1d3 damage every time you do so. You can shoot through targets on the other side of windows at no penalty, and doing so will shatter the window.

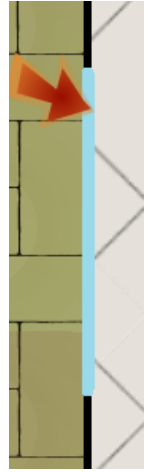

## Reinforced Windows

Not every window is easy to punch through. Some are reinforced with plasteel or nano-technology or some other future thing. Reinforced windows are similar to other windows, but are distinguished by the sharp grey bars which run down their length. Reinforced glass can be seen through, but cannot be moved or shot through. It functions like a wall when used as cover, but does not block anyone's line of sight. Try standing behind some and mooning the enemy; it's a great laugh.

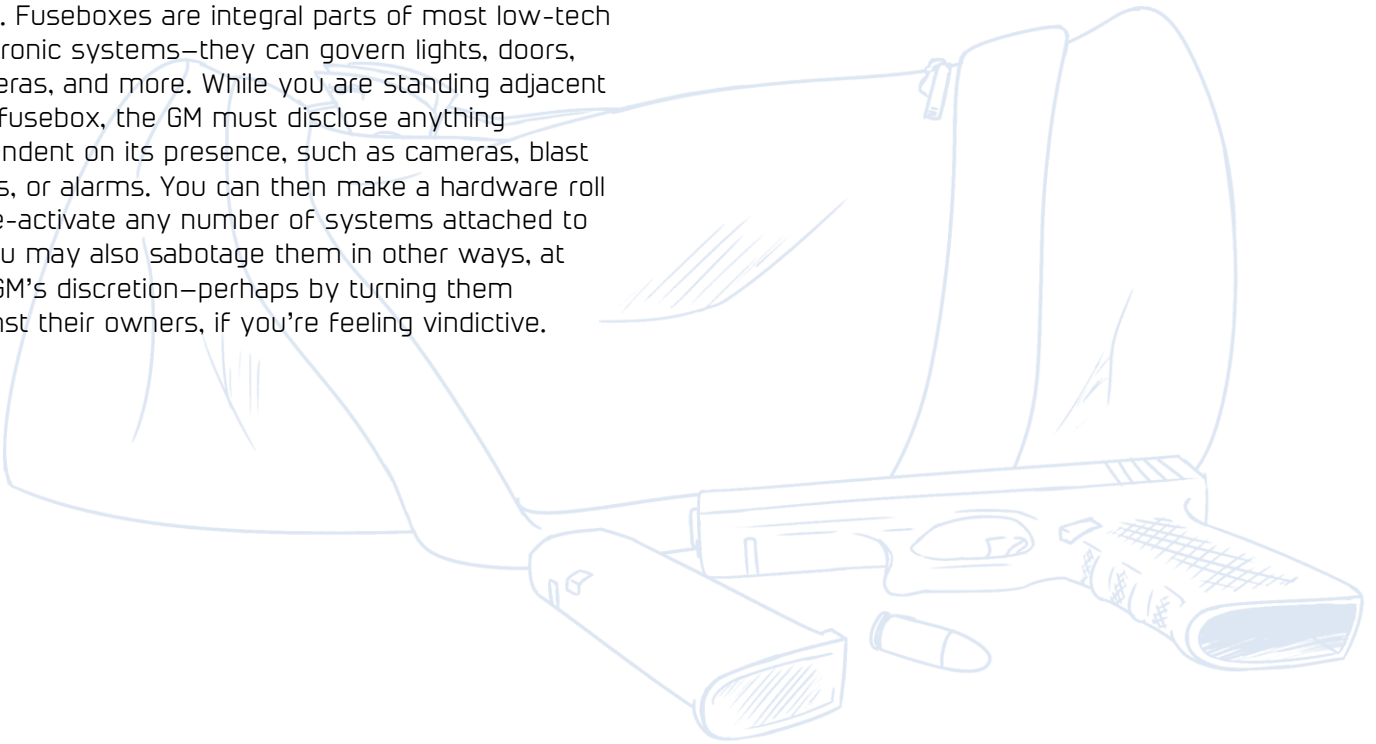
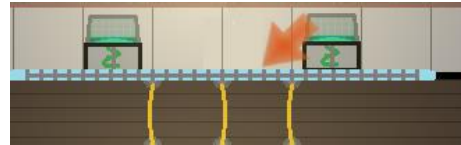

## Railings

In perilous places, these yellow safety railings are the only thing separating you from a massive abyss and an ignominious splattery death. While you *can* jump over these quite easily, doing so will usually result in a long drop and a sudden stop. Railings can be passed over with no action cost or roll. They serve no function on their own except to denote special borders. They do not obstruct line of sight and do not serve as cover. They are often placed next to places where you don't want to be, or else shouldn't be in the first place: such as safety rails on the edges of rooftops, or restricted space markers.



## Walls

Brick and wood. Opaque, sturdy, keeps out the draft sometimes. You know what a wall is. Walls are sharp black lines. They block sight, serve as cover, and things can't move through them. They can be blown up by certain items. Moving on.



## Air Vents

Ever since the 1970's, people have been using air vents to infiltrate and move through high-rise buildings all around the world—with varying degrees of success. Now that most criminals are made (at least in part) of ink, it's been increasingly difficult to keep ventilation secure. Air vents

are represented by bright purple lines. At the start of a job they are opaque and cannot be moved through, but you can open them one of two ways: silently, with a hardware roll and an action; or with no roll **or** action, at the cost of alerting everyone within five squares of your presence. Once an air vent is open, characters may move through them—however they must expend 1 extra action when entering or exiting a vent. You may also fire a weapon through an air vent, at a -4 penalty.

## Collapsed Walls

In areas of widespread conflict, vandalism, or neglect, it is entirely possible that sections of walls or windows will collapse.

When this happens, it may become possible to pass through them. Collapsed walls--denoted by wavy orange and grey lines--do not obscure vision, and you may move over them: however, it takes an entire action to do so which might place you in a compromised position. You can move through a collapsed wall while avoiding the action cost by making a successful athletics roll. If you attempt to make an athletics roll to pass over a collapsed wall and fail, you remain where you presently are, and critical failures will deal 1d6 damage to you.



## Structural Weaknesses and Rubble

Even the fanciest buildings must, unfortunately, abide by the prevailing laws of physics. This means that load-bearing walls, pillars, and beams are just about everywhere—and anyone who's fond of wanton devastation can make good use of that.

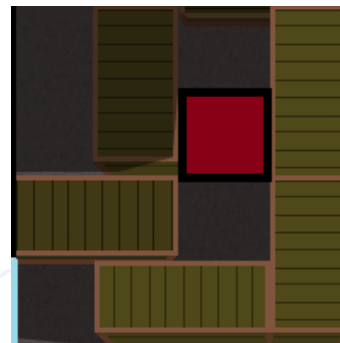

Many buildings in TP have structural weaknesses, like those illustrated here. Structural weaknesses are points in a building that can be destroyed either by explosives or other sufficiently powerful impact.

Whenever three-fourths of a building's structural weaknesses are destroyed, the building begins to collapse: in **1d6+X combat rounds**, where X is the number of supports remaining, it will collapse—**killing everyone inside** and replacing the structure with a mountain of rubble. If all of the building's weaknesses are destroyed, the building will collapse in 1 turn, with identical results.

Rubble does not obscure vision; but anyone standing in it is treated as having cover against all non-adjacent enemies; and anyone moving through it must make a successful athletics roll, or else they will suffer 1d3 damage whenever they move through it.

## Loot Zones

Loot zones are where the best part of robbery—that is to say, the actual theft—happens! Loot zone borders are denoted by golden-dotted lines. Aside from their borders, loot zones have two other attributes: **ease** and **take**. Ease is a simple formula, usually involving one or more dice—for example, **'2d20x1000'**. Take is a flat number which indicates how much money is in the loot zone—IE **'100000'**. Both of these are often indicated somewhere in the map: either in the legend, or on a nearby piece of scenery; but sometimes, in the case of secret treasure or hidden valuables, the ease and take of a loot zone are secrets only the GM knows. While standing in a loot zone, you may spend a single action to loot the place. When you do so, consult the loot zone's ease, roll any indicated dice and perform any indicated additions, and then subtract that much from the loot zone's take. That is the amount of money that goes directly into your bag. When a loot zone's take has been reduced to 0 by any means, it can no longer be looted.

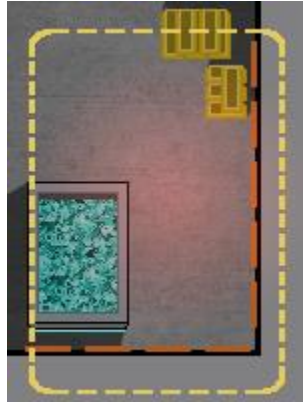

## Playing the Game III.V: Security Measures. Both of Them.

### Security Cameras

Cameras are now, and always have been, a real pain in the ass for anyone who's trying to stay out of the spotlight. Security cameras are the worst of the bunch: consisting of a high-tech camera mounted on an automated swivel (or a stationary platform), they can watch over a given area and beam an image back to the local security force in less than a second. However, they are dependent upon a sentient operator—which means that if you somehow manage to neutralize the guy watching the cameras, then they're just so much wasted plastic. There are two kinds of security cameras: **WIRED** cameras (right) and **WIRELESS** cameras (left). All security cameras have **SIGHT** of everything within 8 spaces, except for things immediately behind them. (For more information on sight, see **Sneaking II**, later in this manual.)



**Wired** cameras can only be disabled by sneaking up next to them and making a **hardware** roll, or else by disabling the **fuse box** which supplies power to them. **Wireless** cameras can only be disabled by hacking into them. For more information on hacking cameras, see **Hacking I-IV**.

**Both kinds of cameras** can be rendered useless by eliminating the person watching them.

### Metal Detectors

It is a common knowledge that people who are planning on doing evil do not always wear their intentions on their sleeves. Thus, for the purposes of detecting things like bombs, concealed weapons, or midget robots cunningly concealed within your pubic regions, the Metal Detector was invented. These devices trigger an alert if you pass through them while carrying any weapon that does not have the “undetectable” trait. Augments and metallic components inherent in your character's being—if they are a robot, for example—do not set off metal detectors; but the GM may choose to spook you with the threat of such, if he is so inclined.



**Note from the editor:** There will inevitably come a time when a Toonpunk GM elects to spook a player who has passed through a metal detector by causing a guard to take notice in a fashion that is not fatal to the mission. There may be some players who dispute this and may refer to this part of the manual to explain why this is impossible. For that player: relax, it's not that important.

## Playing the Game IV: Skills

Every character in Toonpunk is defined by a set of skills—also called attributes, abilities, so on and so forth. Each of these skills are scored from **-1** to **10**, where a higher number represents a higher proficiency with a given skill. Characters with 10 points in a skill are masters in the field, and characters with 0 points are dangerously inept. Characters with -1 points are **unnaturally bad** at something, and a danger to themselves and others.

You will find information on how to determine your character's skills in the **Character Creation** portion of the manual, but we have a fair ways to go before we get there. In the next 30-odd pages, you will find instructions on how to use the various skills; beginning with a rundown of what they do:

**Grit:** Gritty characters are stubborn, tough, and healthy as horses. Not only is Grit your physical toughness, but also your mental fitness—your ability to stubbornly resist the mind-warping bullhonky this job throws at you. In Toonpunk, Grit determines how many hit points you have—that is to say, how much raw physical trauma you can sustain before keeling over dead. It is also used to resist the effects of poisoned weapons, psychological weapons, and certain other hostile effects. The GM may also ask you to roll grit if you come under physical duress, or if you stumble upon something that mortal minds were not meant to know.

**Athletics:** Do you have somewhere to be in a hurry? Are you the kind of spastic monkey boy who never walks when he can backflip? When you are pumping iron, do you get the feeling of coming? Then you might be an athletic character! The athletics skill not only determines how quickly you move during games, but is also called upon whenever you attempt strenuous physical activity such as lifting, jumping, climbing, or arm-wrestling.

**Murder:** The most important part of violent crime is the violence! Murder is a catch-all skill used for any action that involves you attempting to inflict physical harm upon anyone else, whether through shooting or stabbing or boxing or strangling or any other horrible method. Characters roll murder whenever they want to fuck someone up.

**Acting:** You might have a heart full of black, but you can have a silver tongue too. Acting is the fine art of deception through words: confidence tricks, fake identities, swindles, bluffing, and bold-face lying.

Acting is most commonly used during conversation, whenever you are affecting an air or telling a lie; or when the GM otherwise declares it necessary.

**Sneaking:** There are legends in the espionage business who everyone knows, but nobody has seen: legends like Head Honcho, Lady Blue, or the one they call... Invisibear. Sneaking is rolled to avoid making noise while moving, as well as to perform stealthy feats of agility or dexterity—such as picking pockets, switching two glasses around, or discreetly planting a listening device. (see **“Sneaking”** on **page 33**). It is also used in place of murder for weapons with the “assassin” trait.

**Hacking:** Hackers disable security, shut down cyborgs, and slice through cutting-edge locks with nothing but a laptop, and do it all from the comfort of somewhere quiet. Hackers are responsible for gathering, relaying, and using information for the rest of their team's benefit. They are best served by avoiding combat entirely. Hacking is rolled when using computers (see **“Hacking”** on **page 35**), and the GM may call for a roll whenever a character uses any similar piece of technology.

**Hardware:** Even in the incredible modern world of today, you cannot undersell the value of conventional mechanics: people who know which wires to cross, which ones to cut, and when to flip the switch. Hardware is rolled whenever you wish to alter, repair, or quietly sabotage a piece of technology; but perhaps more importantly, it is key to the operation of many useful gadgets.

**Perception:** In the business of secrets, the only thing more important than hiding them is sniffing them out. If you want to hear and see what other people don't want you to, then you need perception: this skill determines how far you can see and hear, which is key to locating hidden enemies; and aside from that, it is rolled whenever you are attempting to detect something hidden—be it a hidden switch in a wall or a subtle twitch on a liar's face.

**Artistry:** Finally, we have the artist: the master and commander of the Ink. Basically this skill lets you cast spells, it's this whole thing. Artistry is rolled whenever a character uses doodles (see **“Doodles”** on page on **page 20**). It has no other particular use.

**Nonsense:** Nonsense is never rolled. It's special like that. For every point of nonsense your character has, they can store 1 extra power burst in their inventory. What does that mean? Well, let me explain...

## Playing the Game V: Rolling and Power Bursts

All Jobs in TP—from frenzied fistfights to well-executed heists—depend upon many factors. Chief among those, however, are the **dice roll** and your **abilities**: your abilities affect the way you interact with NPCs and the world map, and your odds of success in strenuous encounters; and the dice roll represents the random flukes of skill and chance that can save your life, or cause the best-laid plans to come crashing down. The two are linked, and the success of the latter depends on the former.

Your success or failure within TP is, like many games, determined with a **roll of the dice**.

Whenever you attempt a strenuous action during a Job you roll a D10, make a note of the number, and then, compare it to your character's relevant skill. If the number you roll is equal to or less than your skill number, then you manage to succeed in whatever you were trying to do. For example: if you are trying to shoot someone, you would roll a d10 and compare it to your murder score. As such, skills with a high value are very unlikely to fail. However, depending on the circumstance in which you find yourself in, penalties of varying strength may be applied to your rolls...

### Penalties: Your Biggest Issue

The most inconvenient thing you will have to deal with as a toonpunk—and you will have to deal with these a *lot*—is penalties. “Penalty” is a catch-all term given to any time where harsh circumstances temporarily reduce the value of your skills. They are represented with negative numbers such as -1, -2, -3, and so on.

Penalties are usually incurred whenever you do something which is particularly difficult. There are many things mentioned later in this manual which mandatorily impose penalties—things such as firing multiple bullets in a single turn, or moving quickly while attempting to remain silent.

However, the GM can ALSO impose penalties at their leisure, for basically any reason at all. The rationale and intensity of penalties imposed upon you are entirely up to their discretion. If you're lining up a sniper shot and it's raining or windy on the battlefield, they can choose to penalize you as gently as a -1 to your roll or as hideously as a -10. If you tell a lie they find to be of poor quality, they might penalize your acting. If you are wearing tinted

glasses while trying to examine a dark room, they could penalize your perception. Whether or not they do is entirely up to their discretion; and the GM has free reign to impose or waive penalties at any time. However, he shouldn't be a dick about it—I'm looking at *you* when I say this, Malik.

Penalties to any single attribute are cumulative regardless of source, but only apply so long as you are subject to the circumstance which inflicted them. For example: if you were attempting to identify a specific target in a crowd, the GM might penalize your perception twice: once, at -2 because of the density of the crowd, and again at -8 because you are wearing a blindfold. This would, cumulatively, impose a tremendous -10 penalty and make spotting your target impossible. However, if you were to remove said blindfold you would lose the -8 penalty, and only be subject to the -2.

It is possible for multiple different penalties to be assigned from repeated exposure to the same source. For example, firing multiple shots from a weapon will impose a -4 penalty each time you do it. Penalties from the same source function identically to other penalties with the notable exception that they can be dispelled by a single power burst. Don't worry, you didn't miss anything, power bursts are explained on the next page.

The various enemies and NPCs you encounter can be penalized in the same way as you. Any and all GMs who happen to be reading this, please make sure to use your powers for good.

### When Do You Roll?

Generally, there are two circumstances which will call you to roll the dice: either because the rules in this book said you should, or because the GM asked you to. The former examples are, of course, illustrated in this volume; and these range from skill rolls while using items, to damage rolls from weapon, to blunt rolls if your character wants to smoke up for a little while.

The second situation has no special rules attached to it, and is about as simple as it sounds. If the GM asks you to roll the dice, do so. Generally, the GM is expected to disclose what skill you are rolling the dice against, and any penalties attached; but if they choose not to, don't give them a hard time about it.

## Power Bursts

In addition to their skills, resources, and comrades, all characters in TP have one final ability: the Power Burst, where a character musters all of their willpower and skill into a single instant and pushes themselves past their normal limits. To use a power burst, declare your intentions at any point during your turn—including immediately after you have rolled. Whenever you spend a power burst, you may ignore a single source of penalties, of your choice, on each of your actions that turn, regardless of how large that penalty is, or how large they are cumulatively. That means that, while using a power burst, you can ignore the -2 penalty imposed by shooting at a distant target, or a -4 penalty imposed by shooting multiple times, but not both at the same time. Power Bursts may not be used to alter the outcomes of rolls dependent on skills in which you have -1 points, but you may use as many power bursts in a single turn as you want.

You may only use each Power Burst in your inventory one time—so use them carefully, as they are generally in short supply. By default, you gain one power burst per job completed; though this number is subject to change based on your equipment and other special circumstances, including job rewards. By default, all players begin with one power burst, and can store up to three. Characters with -1 in nonsense cannot use or gain power bursts at any point.

Finally, one last rule. You cannot use power bursts in any circumstance which would damage or otherwise negatively affect someone who also has power bursts. That means no bursting and shooting them, no bursting and shooting near them with explosives, no bursting and shooting something which then falls on their head, or any other loophole you think you've found.



## Mixing Math: The Golden Rule

Occasionally during a game of toonpunk you may have to perform multiple mathematical operations to resolve a single action: for example, you might need to increase the damage of a weapon by 2, and divide it by half. When this happens, the golden rule is always that you should **Add, Subtract, Multiply, and Then Divide**, in that order. So, for example, if you were firing a weapon with ammunition that gave +3 damage, and had a gun that does 3x damage against targets you would **first add** 3 to the weapon's damage, and **then** multiply the resultant number by 3.

## Rounding Numbers

If you have to round a number when playing this game and it doesn't specifically tell you to round up, round down. No exceptions.

## Close Enough: If the GM Gets Bored

Sometimes during a game of Toonpunk, you'll be doing something that's...a little less than exciting. Maybe it's something that doesn't require much effort, maybe it's some particular minutiae, maybe it's just bitch work. That's when "**close enough**" comes into play.

The GM has the right to say **close enough** any time a character attempts something. When the GM declares close enough, the character automatically succeeds at whatever they were doing. This is used to prevent you from having to spend time acting out such trivially easy (but time-consuming) things as data entry, trekking back and forth between two locations, or outrunning a really fat guy. The GM should think *very* carefully about declaring close enough for NPCs.

## What the Hell?! Things This Book Doesn't Adequately Explain

It will inevitably happen that during a game of Toonpunk, one of you crazy critters will think of something we didn't. When someone—be it the players or the GM—asks a question that cannot be definitively answered by the material in this book, it falls to the GM to arbitrate as he or she sees fit. It's a good idea to keep a list of these fringe cases and the rulings issued, for future reference.



## Playing the Game VI: Buying Stuff

The last basic pillar of Toonpunk is buying stuff. You're going to do a **lot** of shopping in this game. To carry out a job, you need to buy stuff. To get the take back to your lair, you need to buy *the right* stuff. After you steal a lot of money, you're gonna use it to buy—of course—even *more* stuff!

There's a big list of the stuff you can buy, which starts halfway through this book and doesn't stop until just before the end. Everything you buy there—from guns, to drugs, to henchmen—has a listed monetary value. If you can pay that much money, you get the item. Sometimes item costs will be presented as formulae, or reference the variables **EX**, **CH**, **WS** or **MM**. These are references to the four specialty skills **Explosives**, **Chemistry**, **Weaponsmithing**, or **Mastermind**, all of which can reduce item prices. More information on them can be found in the **Character Creation** section.

## Playing the Game VII: Turn Order and Taking Your Turn

Toonpunk, like many other games, is turn-based: players go one after the other in a repeating order, which is determined in-game. During each character's turn, they can attack, run, climb, hack, sneak, or whatever else they need to do. The order in which players proceed is called, **Turn Order**.

Turn Order **can** be decided any time the players start a new encounter, if it is convenient for the GM; but during downtime and certain kinds of tension encounter, it **can** be safely ignored. However, it **MUST** be decided every time combat begins, and **SHOULD** be decided in most tension scenes, for the convenience of all those involved.

Every time a new encounter begins, turn order is reset. Turn order is decided with a roll of the dice: at the start of an encounter, all characters involved roll a D10 and add their Athletics score to the number. Characters then compare their numbers, and proceed to take their turns from highest to lowest total number, and then repeating. The effects from the actions taken in a turn are resolved as soon as they are taken. In the event that two or more characters have the same initiative number, they must roll initiative again, and the highest-rolling character goes before the others.

Turn order may not need to be rolled at all if the action the players take is sufficiently brief—say for example, swiping an item off a table, lifting something out of a pocket, or making a single well-coordinated attack which leaves an entire roomful of people dead. Generally, if it would take less than six seconds, turn order can be safely removed from the equation.

At the start of your turn, you may choose to delay and wait—taking your turn later instead of now. You must choose when you want to take your turn when you delay, and your position in the turn order is changed to that point.

During a turn, all characters, enemy and ally alike, are afforded **TWO** actions, and no more. These two actions can be allocated one of three ways: **Movement**, **Attacking**, and **Whatever**.

**Movement:** During a turn, players may move a pre-determined number of squares. Your movement speed is **equal to your athletics skill—or 3, if your athletics is 2 or lower**. Players may spend any number of actions on movement, and doing so with two or more is referred to as **Double Moving**. If, while moving, a character attempts to perform a feat of athletic skill—IE climbing a fence or vaulting over an object—it is strongly suggested but not mandatory that the GM ask said person to roll athletics for success.

**Attacking:** Unless your crimes are exclusively fraud, embezzlement, and other ~~pussy~~ white collar crimes, you're probably going to have to rough somebody up. You can use **ONLY ONE** action each turn to **Attack**. "Attack" is a catch-all term used to refer to using weapons, using Doodles, or hacking something. For more information on each of these three things, see the **Combat**, **Doodles**, and **Hacking** portions of the manual.

**Whatever:** This is for the rest. Reloading guns, picking things up, using equipment, picking locks, stabilizing teammates, jerkin off, taking pills, you get the idea. Within the great majority of this manual, **Whatever Actions are referred to simply as "actions", and any reference to an action which is not declared as being either attack or movement is presumed to be in this category.** For a more precise list of things you can do with whatever actions, see **"Whatever Actions"** on page 26.

# Character Condition: Dealing and Taking Damage

## Character Condition I: Health

Getting shot hurts—it hurts a *lot*, in fact. Most people can't get shot more than once or twice without passing out from the pain (and subsequently dying of the blood loss); and while most punks will be shot at least once in their careers, that is far from the only pain they will ever have to endure. Every time you take damage—be it through falling, bleeding, burning, gunshots, or some other source—you will lose a number of points from your **Total Health**. Your Total Health is a measure of your current physical condition; and like other character stats, higher is better. If your Total Health ever reaches 0, you will be **incapacitated** (See: **Incapacitation and death**).

Your Grit stat dictates your total health, and thus your survivability: your total health is equal to the number of points you have in your Grit stat, plus 5—so a character with 2 grit would have 7 Total Health, and a character with 10 grit would have 15 Total Health. Any damage you suffer will heal between encounters, barring special circumstances.

Your Total Health begins at its maximum level on each mission, unless strenuous or unusual circumstances have been placed upon you, as the GM sees fit.

## Character Condition II: Incapacitation and Death

Should the worst come to pass during a job—should your plan prove faulty and your skills fail you—you may suffer enough damage to reduce you to 0 Health. When this happens, you will be **incapacitated**. While incapacitated, you are bleeding and crippled: you cannot perform any action whatsoever, and are wholly at the mercy of your enemies. They may take anything from your inventory that they want, and can move you around as they please.

While you are incapacitated, you must roll grit every turn; and for every turn you spend incapacitated, a scaling -2 penalty will be inflicted upon your rolls—so that the second time you roll, you will have a -2

penalty, and the third time you will have a -4, and so on until you reach -10.

Once you have failed three grit rolls, you will die. If you are unfamiliar with the ramifications of death, please go play in traffic until you understand.

*Editor's Note: Don't actually do that.*

While incapacitated, death can be prevented so long as a member of your team gets to you before you die. At the cost of a single action and nothing more, another player can **Stabilize** you—they, perform the rudimentary medical functions required to keep you from dying. When stabilized, you do not have to make grit rolls to stave off death. You will still be out of commission until you get to a hospital (or something similar), but you won't die.

After taking damage, you will find the recovering your lost health during a mission to be difficult, but not impossible. At the end of each combat encounter, if you have lost any health points, you will regain a number of health points equal to half your grit skill, rounding down—so that a character with grit 8 would regain 4 health points at the end of a combat encounter, but a character with 9 would *also* regain 4 health points. Additionally, certain items available on the black market can restore your health in varying amounts.

## Surrendering and Getting Tied Up

Getting beat on isn't the only way to get incapacitated. It is possible that a character might surrender to a hostile party. Surrender is defined, for mechanical purposes, as any instance in which a character has remained compliant with a **Freeze!** order (as defined in **Combat VII: Combat Actions**) or otherwise expressed compliance with the intentions of a hostile party for one or more turns. A character who has surrendered can get **tied up**, if a hostile party then uses the **Zip Cuffs** item on them.

A character who is **tied up** is, like an incapacitated character, unable to do anything. A tied up character can be cut free by a teammate, at the cost of a single action. Characters who are tied up do not lose any health while tied up; and if cut free will revive exactly as they were beforehand. Enemies may remove anything they want from a tied up character's inventory.

## Carrying the Dead and Dying

It will occasionally happen that you will want to move someone who has just been recently incapacitated. Whether you're a field medic trying to rescue an injured teammate, a kidnapper moving a tied-up hostage, or a sniper setting a trap, you're gonna have to hulk the guy up over your shoulders or at the very least drag him.

When you want to pick up a character, they *must* be incapacitated in some form—either bound, unconscious, or dead. Conscious and unbound characters cannot be carried under any circumstances. They wiggle too much.

Picking up an incapacitated character requires a single action, but putting them down again does not. While carrying a character, you cannot double-move.

## Miraculous Recovery

Sometimes, dying doesn't stick. That's the weird thing about being made of ink: you can take a *lot* of punishment, and sometimes you'll miraculously revive from things that should've killed you.

If you fail your last grit roll after being incapacitated, you have one final chance to cling to life: the "Miraculous Recovery" roll. For each power burst you currently have saved up, roll 1d10; plus an additional 1d10 just for the hell of it. If any of these dice roll either 1 **OR** 10, you instantly revive with 1 health point, lose all your power bursts, and do not gain any power bursts at the end of the job. You may only make one miraculous recovery roll per game.

## Character Condition III: Damage and Barriers

Whenever your character suffers physical harm, it does a certain amount of Damage. Weapons all have a damage value, abbreviated as **DAM**—this is a measure of how powerful the weapon is. Other hazards—like falling, broken glass, or fire—can damage your health as well. Every time a character—be it you, your teammates, or an enemy—takes damage, their health can potentially be depleted. However, if a character has armor, shields, or other barriers, they can reduce or entirely negate the effect of enemy weaponry. Barriers are conveyed via equipment and, in some cases, augmentation. They come in three types:

**Armor** (abbreviated as ARM) is a simple form of protection: plates, weaves, and meshes that hinder small arms and blades. Ballistic jackets and ceramic plates are both examples of armor. In battle, Armor is effectively an extension of your Total Health: whenever you would normally take damage, your armor takes damage instead until it is depleted. Armor, unlike health, does not regenerate between fights: it may only be repaired during downtime.

This means that once a suit of armor has been spent, it will be useless until you have moved to a safe location. However, armor has one more trait that distinguishes it from your health: if a character wearing armor takes a hit from a weapon with **less than half the armor's current strength**, the damage will be **negated altogether**. In this way, a character with a vest that is currently at armor 5 will be resistant to harm from any weapons that do 2 or 1 damage, but will still be vulnerable to any that do 3 or greater.

Armor is not completely immune to small arms: every time a suit of armor negates an attack, keep track of the damage it would have taken. After a piece of armor has taken damage equal to its current value, it no longer negates attacks—instead, whenever it would negate an attack, it instead takes 1 point of **chip damage**. It will continue doing this until the start of its wearer's next turn; and after its wearer's next turn begins, it will continue to negate attacks as usual. Chip damage cannot be reduced by effects that affect or negate regular damage: so over time, even the strongest armor can be worn down by repeated impacts.

Armor normally comes in three materials: **Mesh**, **Ceramic**, and **Plasteel**. Mesh is the weakest but the lightest, while plasteel is heavy and difficult to maneuver in; and ceramic strikes a healthy balance between the two. Some weapons have the **Pierce** trait, which allows them to completely ignore certain kinds of armor and damage their wearer's health directly. See '**Pierce**' on **page 27** for more.

In combat, any weapon which can pierce one grade of armor can also pierce weaker grades: a weapon that can pierce ceramics can also pierce mesh, but not plasteel; and a weapon that can pierce plasteel can pierce all three.

A suit of armor's stat block looks like this:

**Plasteel Power Armor (\$500000)**  
**ARM: 15 | Plasteel | Armor**  
**[Description]**

**Shielding** (abbreviated as SHD) is another form of barrier. Shields are almost like armor, with two major exceptions: firstly, shields regenerate to full strength in between combat encounters; and secondly, shields never entirely negate damage like armor can—they will always be decreased whenever they absorb damage, necessitating a steady hand and a keen mind to use them effectively. In this way they are like an extra health bar.

A shield's statblock looks like this:

**Personal Shielding Unit (\$50000)**  
**SHD: 10 | Equipment**  
**[Description]**

**Special** barriers (abbreviated as SPC) function similarly to shields and armor, in that they can reduce or negate damage; but beyond that, they are almost wholly different. They may call upon strange power sources or confer unique benefits to their wearer. Special barriers are usually conveyed via expensive equipment, and have rules which are too varied to explain in this portion of the manual

The three kinds of barriers have priority over each other, and will always take damage in a specific order. Shields always take damage first, special barriers always take damage after shields, armor always takes damage after special barriers; and only after **all of these** are exhausted will a character's health take damage.

## Character Condition IV: Remaining Incognito

The Modern world is a wild and dangerous place, where fistfights can break out at a moment's notice and everyone is on the lookout for guys like you. Unless you want to be arrested before your heist even starts, you're going to have to know how to blend in with the crowds, and dodge prying eyes.

While the majority of civilians are uninformed (and proud of it), law enforcers all throughout your theater of operations will be more-or-less abreast of your many villainous actions. They're the ones you need to worry about: when you are out and about, and you pass through a law officer's field of view, the GM may elect to make a **Suspicious Person Roll**—a roll which does not rely on any stats of the officer's, and instead is determined by **your** actions and equipment. If it succeeds, the officer will recognize you as a criminal!

By default, this roll has a target of -1, meaning that under normal circumstances they will never recognize you; however, this target can be modified by your notoriety and current equipment, in the following ways:

- **For every 10 points of Infamy you have**, lawmen will get a +1 bonus to their Suspicious Person Roll.
- **If you have a short weapon on your person**, lawmen will get a +2 bonus to their Suspicious Person Roll.
- **If you have a weapon or item with the "Dead Giveaway" trait**, lawmen will automatically pass their Suspicious Person roll. Unless otherwise noted, **all Long Weapons** have this trait.

If a lawman ever successfully identifies you as a suspicious person, you will be approached for questioning; and from then on out, it's up to your sense of guile to get out. If you manage to successfully lie your way out of suspicion—perhaps by judicious use of your **Acting** skill—then you will likely be sent along on your way; or you may simply try and outrun them—though any policeman worth running from will no doubt have a radio with which to relay news of your appearance.

If you fail to escape their notice, the lawman will attempt to apprehend you; and while you may resist arrest by engaging in combat, you will not be afforded a surprise attack round, and the sound of fighting may alert civilians and police alike. Of course, all of this remains up to the GM's discretion: consult with your GM before your game starts to learn if they will be enforcing this rule, and if so how stringently. Plan accordingly.



## Reputation I: Infamy

This part of the manual is designed for long-term campaigns. Before you begin playing, ask your GM if they intend to observe these rules and adjust your plan (or lack thereof) accordingly.

Your reputation has a nasty habit of catching up to you in this line of work. While you can't escape a rap sheet, you can decide exactly what this means for you.. **Infamy** is a measure of how feared, revered, and wanted you are. It affects how quickly people recognize you, and how eager they are to get out of your way.

Infamy is graded on a scale of 0-100, and is shared between all members of a crew. Infamy 0 means that you are almost entirely unknown as a criminal element; while 100 means you are a notorious and accomplished criminal, on par with Jon Dillinger or Al Capone. Most crews will begin the game with infamy 0, and acquire it at a steady rate.

Infamy is a two-edged sword. While it is highly effective at scaring civilians, gangsters, and law-enforcers, it makes it difficult to conceal yourself, or escape from a heist in progress. You and your crew should think carefully about how much impact you want to have on the world around you.

### Good Things About Infamy:

- **For every 10 point of infamy you have**, you may add 1 point to your acting score, but only for purposes of intimidation; and only so long as your acting skill is 0 or higher.
- **For every 20 points of infamy you have**, reinforcements take 1 more full combat round to arrive after combat starts.
- **For every 20 points of infamy you have**, the range of your **Freeze!** increases by 1 square.
- **For every 25 points of infamy you have**, enemies will be more hesitant to approach you: you must be compliant for **one additional turn** before you can be arrested. You **may** still be arrested after 1 turn, if you like.
- **For Every 35 points of infamy you have**, you may **heal one additional time** per encounter.
- **For every 45 points of infamy you have**, you can roll 1 extra die when you make your miraculous recovery roll. After all—by this point you've got a reputation to live up to!
- **When you reach 100 infamy**, you may reroll 1 die each turn and choose which result to keep. If you're that infamous, you'll definitely need it.

### Bad Things About Infamy:

- **For every 10 points of infamy you have**, any police you encounter will receive a +1 bonus to their Suspicious Person rolls.
- **If you reach 15 points of infamy** and more than three people have witnessed you committing a crime without a mask, the police show up at your house and throw you in jail. At that point you'll have to either attempt a daring escape, or make a new character. Just wear your mask.
- **For every 20 points of infamy you have**, the GM may deploy 2 more points' worth of enemies against you. If you don't know what that means, read the **GM** section at the end of the manual. In brief: it means more enemies.
- **Once your infamy reaches 50**, civilians may begin making Suspicious Person rolls at the GM's behest. They can receive a bonus to their target from your infamy like policemen; but they only receive half as much.
- **Once your infamy reaches 100**, you become the target of an **interplanetary manhunt**. When this happens, every single person you encounter recognizes you on-sight. This continues until you drop down to 50 infamy or less. Good luck.

### How to Get Infamous:

- **For every 50000 hands you steal** on a single job, you gain 1 point of infamy.
- **For every law enforcer you kill**, you gain 3 points of infamy. For every civilian you kill, you gain 5. Gangsters, mutants, robots, and anything else that is not a living policeman or bystander doesn't count.
- **If you have no witnesses and were not recorded on camera**, your infamy will not increase regardless of your performance during the job—after all, it could've been anyone! You may work around this with the **calling card** item, if you want to gain infamy without exposing yourself during the heist.

### How to Get Anonymous:

- **You can spend 1000 hands** to reduce your infamy by 1, to a minimum of 1. You can do this as often as you want.
- **At higher levels of infamy**, at the GM's discretion, you may undertake a mission to remove evidence against you by infiltrating the offices of whichever entity is investigating you. **The GM is encouraged to make these missions more challenging each time you do it.**

# Acting I: All you Need to Know

So now that we've spent plenty of time talking about all the ways you can get fucked up, let's talk about what you're going to be doing to keep that from happening. You're going to be bluffing, persuading, cajoling, intimidating, impersonating, falsifying, and telling shameless bald-faced lies.

It's called "acting", children.

Acting is something with which most punks will need to become quite familiar. It's the fastest way to acquire information and earn trust; it's what you use to take hostages, and keep rescuers at bay; and it's what you use to aver your innocence when the police come knocking. It's being as gentle as a lamb or as terrible as a tempest—all of this and more, rolled into one indispensable skill.

The acting skill is used whenever your character wants to lie, seduce, scare, preach, persuade, or otherwise converse with the intention of altering the thoughts or feelings of another individual in any conceivable way. It is, due to the sheer range of options, the most versatile skill in the game; and because it can cover so much ground, the rules regarding its use are fast-and-loose in a way no other skills are. There's only a few rules about acting, and a few guidelines to follow, and all of those are on this page. Without further ado:

**When you make an acting roll**, you must always state, precisely and clearly, exactly what it is that your character says. While you may be tempted to just say "I use acting", and your GM may be tempted to allow it for the sake of the thing, this is a supremely unenjoyable way to conduct yourself: the point of a role-playing game is to play a role, and there is no finer time to play a role than when your character is lying like a rug.

- **Whenever you make an acting roll** of any kind, the GM should assign you penalties based on their own interpretation of how effective your presentation was. If you are telling a lie, they should assign penalties based on how confident you were, or how many inconsistencies they notice. Intimidation should be gauged on how frightening your choice of words and intonation is; seduction should depend on how appealingly you present yourself; and so on and so forth.

- **The GM and the players BOTH** should remember that what appeals to, frightens, or attracts people varies from person to person. The GM should get into character, and assign penalties or bonuses based on how well your acting preys on the NPC's desires, fears, or other emotions.
- **The GM may, on occasion, refuse players the opportunity to make acting rolls.** A GM should do this sparingly at most, and only if there is a very good reason for the character to out-and-out refuse to capitulate to certain interaction: for example, the GM may refuse to allow a player to roll acting to try and hoodwink a character who has secured proof that they are lying; the GM may refuse to allow players to intimidate androids or other things which cannot feel fear; and the GM may refuse players the opportunity to try and seduce anyone who simply does not find them attractive.
- **It is up to the GM's discretion** how much acting it takes to bring a person entirely under your sway. Depending on the nature of your situation, you may be able to get done with a single acting roll (intimidating a frail or cowardly person, for example) or you may need many more (IE attempting to con a shrewd politician).
- **If a player is attempting to manipulate an entire crowd** of like-minded individuals, don't make them roll a million different acting rolls. One is plenty for that.

# Combat: Things You Must Understand in Order to be an Effective Brute or Gunman

## When Should You Resort to Combat?

If you can help it, never. But, since you usually won't be able to help it, we will instead say "rarely". Combat is generally the worst possible way to solve any given problem, because it's the only one where lots of people die and it's the only one where the police get summoned to come and ruin your life. But, because most criminals are really dumb, you'll need to become acquainted sooner rather than later. So soon, in fact, that it's...now.

## Combat I: Item Characteristics

On the Doubleearth, there are many kinds of weapons still in use, from the elegant rapier to the devastating shotgun, to the subtleties of poison or remote explosives. An experienced operator will be familiar with most breeds of weapons, if not *all* of them; and a novice would do well to learn them before they are used against him...

Weapons and other items are defined by several attributes. These are:

**Damage** (abbreviated as **DAM**)—a measure of a weapon's raw killing power. Weapons with a higher DAM stat do more damage: when a weapon is used against someone, it can reduce the victim's health, armor, shields, or barriers by that much.

**Capacity** (abbreviated as **CAP**)—The amount of ammunition a weapon can store before needing to reload. Weapons with a high CAP stat can fire continuously for several rounds, or even an entire job. For every shot you fire, your weapon's current CAP will be reduced by 1. If you ever run out of CAP, you must reload your weapon before you can fire again (See: **Combat III: Guns: Shooting and Reloading**)

**Effective Range** (abbreviated as **RNG**)—The distance your weapon or item can fire reliably. A weapon's RNG is the number of tiles it can shoot away from you before you begin to suffer distance penalties. A weapon with high RNG can shoot a great distance with no penalty.

**Size** (typically **Long**, **Short**, or **Compact**) - The size of your item, which consequently determines where on your body (and which slot in your inventory) you can store it. The sizes available are as follows:

### Long

Weapons with this trait require two limbs to operate properly—they encompass rifles, swords, axes, and heavy weaponry. Long weapons occupy the Long Weapon space in your inventory, and are best used as direct assault weapons. Unless otherwise noted, all long weapons have the **Dead Giveaway** trait.

### Short

Weapons with this trait require only one limb to use properly, and are generally less powerful than long weapons. They occupy the Short Weapon space in your inventory, and are usually used as sidearms or in close quarters.

### Compact

Weapons with this trait are so small that they can be easily tucked into your clothes or affixed to your joints. They occupy the Compact Weapon space in your inventory, and are generally only employed as holdout weapons.

### Equipment

Weapons or items with this trait occupy the Equipment slot of your inventory.

### Head

You get the idea by now.

### Boots

I mean, come on, there's an obvious pattern here.

### Torso

Moving swiftly along.

**Damage Type (Arrow, Bullet, Energy, Throwing or Melee)**—How your weapon of choice achieves its goal of killing, incapacitating, or otherwise maiming your fellows. Certain items and effects only apply to or against weapons with a certain damage type. For a complete list, see **Damage Types** on page 31.

These five statistics define every normal weapon in a TP game. Picking the right is the key to success; but there is one other factor to consider when deciding on the right tool for a job. Many weapons have **traits**, which alter their characteristics in ways either beneficial or detrimental to you. For more information, see '**Weapon Traits**' on page 27; but first, we have some more bases to cover.

## Doodles

Doodling is a multi-faceted school of expertise which revolves around manipulating, disabling, and crippling enemies rather than outright damaging them. In the Doublearth, it is the use of a mysterious particle called 'ink'; but in your adventure it could be nanotechnology, psychic power, or simply even magic. Doodling does not rely on the murder skill, but rather on "Ink points" and the artistry skill. Doodles are defined by several attributes, similar to weapons, though with some key differences. These are, namely:

**Ink Points** (abbreviated as **IP**): ~~Mana~~ Ink points are a measure of how much ink a doodle costs to draw; and, similar to CAP, an amount of IP must be expended with every doodle you cast. Unlike bullets, a character's IP **is limited**—characters have 15 IP to spend, and no more. Much like shields, IP spent will only regenerate at the end of a combat encounter. This means you must be careful with your ink—and you must take several other factors into account.

- **For every weapon** that you have on your person that does **not** have the 'simple' trait, your maximum IP is **reduced by 5**. Items stored in storage (such as a duffel bag) do not count.
- **Some effects reduce the IP** cost of a doodle, and can even reduce it as low as 0.
- Unsuccessful doodles **do not cost any IP**.

## Ammunition

One of the great things about guns is their spectacular versatility. Not only is there a gun for almost every occasion, but many guns are also able to use specialized ammunition to serve multiple roles. **Ammunition** items occupy no space in your inventory, and you can carry as many as you want. However, they **cannot be used independently**, and their stat blocks reflect this. Ammunition must always be equipped on a compatible weapon before you can use it. An ammunition's compatibility is listed in its description. Switching between regular ammunition and special ammunition does not have its own action cost; however, it may only be done while you are reloading. An ammunition item's statblock looks like this:

### Big Bullets

**CAP: -5 | RNG: == | DAM: +3 | Ammunition**  
**Big Bullets are compatible with: Big Gun**

An ammunition's characteristics are relative to the weapon firing them. If an ammunition has a minus symbol before one of its listed characteristics, the corresponding characteristic of its host weapon is reduced by that much. Similarly, if an ammunition has a plus symbol before one of its listed characteristics, the corresponding characteristic of its host weapon is increased by that much. If an ammunition has an equal symbol for one of its characteristics, the weapon's corresponding characteristic is unchanged by equipping the ammunition. If an ammunition has a number that stands without a plus or minus sign, then it wholly replaces the weapon's characteristic, without concern for the original.

Unless otherwise noted, all ammunition types have **Limited-Use: 1**

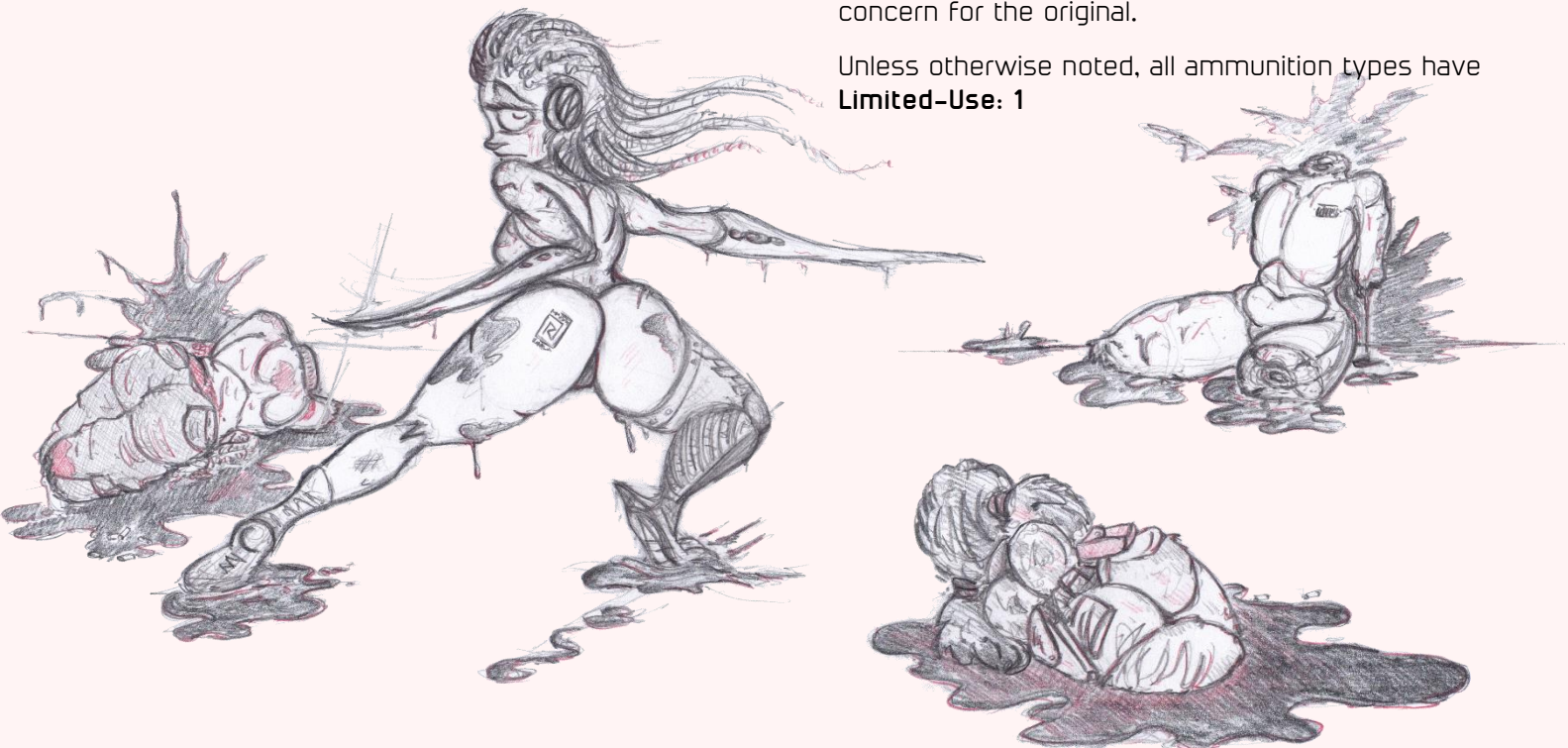



## Combat III: Line of Sight and Cover

Getting shot hurts. You're gonna do it, and it's gonna be done to you. Here's how it works. First thing—range. When you want to shoot someone, they have to be within your weapon's Maximum range—you've read about effective range, and we'll talk about maximum range in just a moment. If your target is within range, you must next check **Line of Sight**. Line of sight is easy to determine: draw a line from your token to theirs, or any adjacent square the target can move to. As long as this line does not pass through walls, smoke, or other sight-blocking objects, you have **line of sight**. Without line of sight you can't attack the target.

Just because you can see your target doesn't mean you can get a good shot at them: this is where **Cover** comes into play. Any **SOLID BLACK** or **BLACK-BORDERED** object is, unless otherwise noted by the GM, cover. Other objects may **also** be cover objects, or block line of sight, at the GM's behest: these can include tables, counters, cars, or whatever else. When you attack an enemy, draw lines from your token to your target, and every unobstructed square adjacent to them—this represents your target's ability to dive, scramble, and duck short distances. Should these lines pass through **any** cover object, your target is **in cover** from you. Cover is relative between individuals and must be established for **every** entity attacking a given target.

If the target is in cover, they are much harder to kill: you may still make the shot, but you will suffer a massive **-6 penalty**. Critical hits against covered targets are treated as normal hits; and finally, you cannot deal chip damage to targets who are in cover.

That bit about critical hits will make sense in a few pages, don't worry.

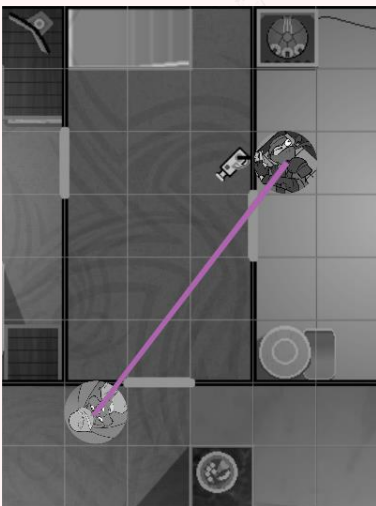

*The line from the ninja passes through the wall. The rabbit is in cover.*

## Peeking

While in cover, you can **peek** around it. This lets you calculate line of sight and cover as if you were standing in a square adjacent to you. This means you can lean around a corner to shoot, without exposing yourself to the enemy. Your position **does not actually change**: this is not movement and does not trigger any effects that rely on such.

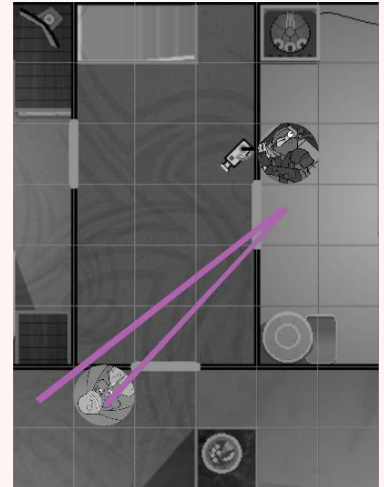

*The ninja peeks to draw his line of sight from a space adjacent to him. He can draw a line to the rabbit's token, but not to the adjacent space. The rabbit is still in cover.*

## Combat III: Using and Loading Weapons

Fortunately, shooting is a very simple thing to do: should you find it necessary to shoot someone during your operations, it is as simple as rolling the dice and comparing the result to the value of your **Murder** skill, with all relevant penalties and bonuses added. If your roll still passes, then you hit what-or-whoever you were aiming at, and deal damage as described in **Character Condition III** back on **page 15**. It's as easy as that. Now for the interesting part.

## Alerting Enemies:

### Silenced and Suppressed Weapons

Let's get this out of the way quickly. Using any weapon that does not have the **"suppressed"** or **"silent"** trait will instantly alert every single person on the map, and anywhere that the GM deems sufficiently close, to the presence and location of the person who fired it. **Do not fire a gun unless you want to fight.** Moving on.

## **Ammunition: Shooting and Reloading**

Every time you fire a ranged weapon, you will expend at least one round. After you've fired a number of rounds equal to your weapon's CAP, you will run out of ammunition, and have to spend an action reloading—will occupy half of a turn you could spend moving or shooting, which can leave you quite exposed. Fortunately, you do not **have** to reload after running out of ammo—you only have to reload once you want to start shooting again.

Reloading does not require a roll; you simply declare your intentions. Unless otherwise noted, reloading a weapon requires a single action. Additionally, you may reload **as many times as you want to** during a job, and do not need to worry about carrying ammunition with you. Where do all the extra bullets come from, you may ask? **Shut up**, that's where.

## **Targeting: Multishot and Multitarget**

During a single attack action, you may use your weapon multiple times to inflict extra damage on your target. However, you will suffer a **-4 penalty for every extra shot or swing you take**. This is called "multishotting", and is invaluable against dangerous targets. You may also attack multiple *targets* each turn—but **you will suffer a -6 penalty** for every person you target beyond the first, which means you will be useless if you try and attack too many people at once. Some weapons have traits which lessen or eliminate these penalties.

## **Weapon Range: Effective and Maximum**

Your weapon's **maximum range** is defined as **twice its effective range**. While you may shoot at targets outside your effective range, this can be risky: Exceeding your weapon's effective range imparts a **-3 penalty** on your shot, stacking with **every third of your weapon's range you exceed**, to a maximum of -9. For example, a RNG 15 weapon's **maximum range is 30**, with a -3 penalty past 15, -6 past 20, and -9 past 25.

## **Weapon Switch: Equipping and Swapping**

Different problems demand different solutions: which means that most combatants will carry two or more weapons at all times. You may carry multiple weapons at the same time, but may only have one **equipped** at any given time. Your **Equipped Weapon** is the only weapon you can attack with, for reasons that should be obvious.

When you start an attack, you may equip any weapon in your inventory. This weapon remains

equipped until your next attack action. **During an attack action**, you may change your equipped weapon at the cost of a **-2 Weapon Switch penalty** to all subsequent rolls, stacking with itself for multiple switches. Finally, you **can't switch to a weapon and then not use it**—weapon switches can only occur if they are followed by an attack.

Some augments allow you to carry extra weapons which always count as equipped. You may equip these with no weapon switch penalty, but you cannot change or remove them during a job.

## **Combat IV: Clashing and Evading**

Unlike the methodical precision of gunfighting, fist fights are desperate bouts of barely-controlled chaos. Fighting on this level is not like any other; and so, while combatants may **choose** to engage in back-and-forth of dealing and taking-damage like gunfighters, it is sometimes better for them to engage in a **clash**. Clashing is a combination of dice rolls and strategy that can decide the fate of a battle in an instant: the winner holds the loser at their absolute mercy.

Whenever a character makes a melee attack, they may choose to **Clash** with their opponent. After doing this, they are unable to take any other actions until the clash is resolved, and must devote their turn to continuing it. Continuing a clash in of itself does not cost an action: this means that if the clash ends on your turn, you may take your turn as you would normally. Each clash is resolved individually, even if a single combatant is in several at once.

When it is time for a clashing character to take their turn, they must decide how they wish to proceed. You have 3 options during a clash.

The first option in the clash is to, uh...**clash**. When you clash, you roll a number of D10s equal to half your murder score and tally the result. Your enemy does the same thing. Whoever gets a higher number wins! The winner of the clash rolls on the **success tables** on the next page.

Most weapons roll on the **lethal** success table; but weapons with the **nonlethal** trait use the nonlethal table. If you are using a weapon **without** the **melee** type, you roll one fewer dice and always roll on the 'Nonlethal' success table.

Your second option is to **Evade**. Evasion works like clashing, except you roll D10s equal to half your **Athletics score** instead. If you win, the clash immediately ends, no ifs ands or asses.

Your last option is to **Absorb** the blow. This is you standing there like a fool and hoping your armor can take it. If you absorb the blow, the clash immediately ends - no rolls required. However, your opponent gets one free attack against you with the weapon they were clashing with. This attack automatically hits, but cannot multishot.

Should you stop being adjacent to your opponent, for any reason, the clash ends. You can start as many clashes as you like with a single action, but roll one fewer dice in each of them for every simultaneous clash. If a combatant is incapable of making attack actions, the clash ends. Finally, if a clash between has just ended, the involved parties may not clash again until a full turn has passed.

If you would roll 0 dice or fewer while clashing or evading, you automatically lose.

## Clash Success and Damage Tables

At the end of every clash round, someone's gonna end up on top. The winner of the round must roll a D5 and compare it to the tables below. There are two tables, lethal and nonlethal, which are respectively exactly what they sound like. Most weapons are one or the other, and are presumed Lethal unless otherwise stated.

Certain weapons, augments, or specialties can grant bonuses to your success rolls. You may pick an effect from higher up the table than the number you have rolled. For example, someone who rolls a 4 can take the effects of 4, 3, or anything less than 4; but *not* the effects of 5.

### Clash Damage Table: Lethal

**1—Light wounds.** You do your weapon's damage to your target. The clash continues for another round.

**2—Deep Wounds.** You do 1.5\* (rounding up) of your weapon's damage to your target. The clash persists.

**3—Cripple.** You manage to not only disarm your enemy, but cut or beat them so hard that their forelimbs are rendered useless. They are unable to take any attack actions, and suffer a -2 penalty to **any athletics rolls**. This persists until they can spare 4 actions to mend themselves, which do not need to be taken consecutively.

**4—Mighty Strike.** You attack your enemy with such force that they take 2\* your weapon's damage, and are pushed a number of tiles equal to **your athletics score** in the direction of your choice. You can choose to follow them at no action cost; and if you do not the clash will end.

**5—Devastating Strike!** Your blows strike with such ferocity that your opponent is left maimed and crippled! You deal 2\* your weapon's damage, and cripple them as per the '**Cripple**' effect above.

**6—Impalement!** You stab your enemy right in the chest, dealing a decisive and almost-surely fatal blow. They are **instantly incapacitated**.

### Clash Damage Table: Nonlethal

**1—Nothing impressive.** You either hit the wrong place, or miss. The clash persists for another round.

**2—Grapple.** You catch your opponent off-guard and direct their movements. Both of you move up to two squares in the direction of your choice. This can be used to position them in a more favorable location, or outright kill them if you position yourself properly. The clash persists for another round.

**3—Disarm.** You manage to knock your opponent's weapon away, causing it to fly 2 tiles in the direction of your choice. Weapons thrown in this way can then embed themselves in any characters standing on the landing point, dealing 1d3 damage to them. The clash persists for another round. If your target is unarmed, this is upgraded to "cripple", as described below.

**4—Cripple.** You manage to not only disarm your enemy, but dislocate or sprain their favored appendage. They are unable to take any attack actions, and suffer a -4 penalty to any athletic rolls. This persists until they can spare four actions to mend themselves, which do not need to be taken consecutively. Should they be equipped with a weapon, you also inflict '**Disarm**', described above.

**5—Fracture.** You manage to damage your enemy's limb so severely that they are incapable of attacking and suffer a -2 penalty to any athletic rolls, and -2 to athletics for purposes of Move speed calculation. More importantly, they cannot repair the damage alone. This effectively removes them from the battle at hand, but they may come back later if hostilities disperse.

**6—Cold-cock!** You knock that fucker out, end of story.

## Combat V: Critical Rolls

Sometimes, fate is slanted dramatically—either for you, or against you. In TP, twists of fate can occur in the form of **Criticals**. When critical effects enter the picture, simple luck can make or break a job.

There are two types of critical: **Critical Success**, and **Critical Failure**. The former represents a sudden burst of genius, or else a trick of fate that allows you to perform an incredible feat; while the latter represents a devil from the machine—a horrible snatch of bad luck, that could upset your plans or imperil your life. When you roll a **Critical Success**, you automatically succeed at whatever action you were attempting, and—where applicable—double the effect. **Critical Failures**, contrarily, cause you to automatically fail whatever you were attempting—and can cause it to backfire spectacularly. An example of a critical success is succeeding on an acting roll so thoroughly you cause a character to stop questioning you altogether; an example of a critical failure is a gun backfiring and blowing up in your grasp.

Whenever you roll a 1 on the D10, regardless of if you would normally succeed or fail, it is possible to have a critical success. Similarly, whenever you roll a **10, and would otherwise fail**, it is possible to have a critical failure. In this way, you **cannot critically fail at a skill you have 10 points in**, but you **can critically succeed at a skill you have 0 points in**. Before you can do either, though, you must roll to **confirm** the critical. To confirm, you simply roll once again against the relevant skill, with a +1 bonus if you are checking to confirm a critical success, and a -1 penalty for a critical failure.

If you pass this roll, the better of the two results happens—you successfully crit, or do **not** critically fail. Contrarily, if you fail this roll, the worse result occurs—you merely succeed normally whereas you might have critically succeeded, or you suffer a terrible critical failure instead of a normal failure.

If, while confirming a critical roll, you make another roll which would itself induce a critical confirmation of the same type—IE rolling a 1 to confirm a critical success, or a 10 on a critical failure—that too must be confirmed, with the result becoming either successively more miraculous or disastrous until you roll a number which does not induce a critical.



When you make a **critical success**, the effect of whatever you were attempting to do is **multiplied by 2**: in the case of combat, your attack does 2x its normal damage; and in most other cases it is left up to the GM's discretion exactly what happens to you. When you make a **critical failure**, that same rule of thumb applies: whatever you were going to do not only fails, but fucks up about as badly as the guy who told John Lennon nobody would ever like his music. What precisely that entails is *also* left up to the GM's discretion, but it basically always sucks.

In combat, though, there's a very simple way to tell what a critical failure does. If a character critically fails an attack roll, they must roll 1d10. On a roll of 1 or 10, their weapon shatters, backfires, or is otherwise rendered unusable for the rest of the mission. On any other roll, it is merely jammed and must be reloaded before use. If a weapon jams and cannot be, or does not need to be, reloaded, then no penalty is suffered.

## Combat VI: Combat Actions

This section is a complete quick reference glossary of the actions you can take in combat, along with their effects and costs.

### Attack Actions!

Attack actions encompass the various ways you can wreck someone's shit: weapons, clashing, hacking, or Doodles. Unless otherwise noted, you may only make a single attack action per turn.

**Attacking:** Attack someone with whatever weapon you have equipped. For more information on the basics of attacking, see **Combat III: Using and Loading Weapons**; this section of the manual serves as a simple list of the things you can and cannot do in the span of one attack action.

As a recap, with a single attack action, you may:

- Attack with your equipped weapon or use a doodle.
- Attack, but multiple times! For every extra attack you make, you take a stacking -4 penalty on associated and subsequent rolls. This is called 'multishotting'.
- When multishotting, you may attack multiple targets at the same time. For every target you attack beyond the first, you suffer a stacking -6 penalty. This is called 'multitargeting'.
- Switch weapons as many times as you like, with a stacking -2 penalty applied to all attacks made that turn for each weapon switch.

During an attack action, you **may not** reload your currently-equipped weapon, even if reloading would not cost you an action.

**Hacking:** Like attacking, but with less murder and more furious typing. We haven't explained hacking yet, but it's a thing you can do with an attack action so we gotta list it here. See the **hacking** section of the manual on **page 35** for more information.

**Clashing:** A more complex attack made with a melee weapon. For more information, see **Combat IV: Clashing and Evading** on **page 22**.

**Guard:** A defensive action that can intercept moving enemies and help secure vital areas. Characters who take a Guard action sacrifice their attack action, but are allowed to interrupt enemy movements with attacks of their own. Characters who are currently guarding should be marked some way to avoid confusion in the coming turns.

If you are guarding, and an enemy uses a move action to enter or move through your line of sight, you may choose to take a **reaction shot**. You may take this shot at **any point** during the target's movement, so long as you still have line of sight to them. You are then allowed to make a single attack against the target, at a **-4 penalty**. This penalty is increased to -6 if the target is double-moving.

If a reaction shot deals damage to the target's armor or health, excepting chip damage, the target loses all the remaining movement in their action. Otherwise, they may continue moving at no penalty. You may only make one reaction shot per guard action. You cannot guard on the same turn you take any other attack action.

**Freeze!:** Having a loaded firearm pointed at you is an unpleasant experience, doubly so when the wielder is ready to blow your brains out.

Freezing isn't an action in itself, but rather **something you can do while guarding**. If you're guarding and an enemy moves within X squares of your position, where **X is your Acting Score +1**, you may command them to Freeze, instead of firing.

A character who has been commanded to freeze must immediately stop moving under penalty of **instant death**. They may use **a single action** to save themselves. If this action puts them in cover, breaks the attacker's line of sight, or incapacitates the attacker, then nothing special happens. If it does not do one of those things, or triggers a reaction shot, then the attacker shoots the frozen character. This shot **automatically hits and incapacitates** the frozen character. The attacker *may not* shoot the frozen character unless they try and fail to escape.

If a frozen character complies with the attacker's demands and stays in place, they will not be shot; and instead may be tied up (see **'Surrendering and Getting Tied Up'** on **page 14**). Freezing does not cost your reaction shot, but subsequently firing does. You may only ever freeze one character at a time, and if you take a reaction shot on any other target, your Freeze is negated. If your target takes any damage, your freeze is negated.

## Movement Actions

This section lists the various ways you can move around the map in a game of Toonpunk. You may spend any number of your actions on these.

**Running:** Your basic movement action in combat. Your movement speed is equal to your athletics skill—or 3, if your athletics is 2 or lower. You may use both of your actions in a turn to run; doing so is called **double-moving**. Running does not require a roll, but does prevent the firing of any weapon with the **Heavy** trait. You cannot move through squares enemies are standing in, and you cannot end in a square your teammates are standing in, but you may move through a teammate's square at your leisure; and you may move diagonally between squares, at no additional cost.

**Climbing:** While running, you can scramble over railings, or some walls (see both on **page 9**). Climbing over other objects, like fences or rubble, may require an athletics roll at the GM's discretion, but does *not* normally require a separate action.

**Tumble:** A short defensive move action meant to allow rapid transition between pieces of cover. At any time you could make a movement action, you may instead choose to tumble. A tumble acts like regular movement, except you may only move up to half your normal movement speed, rounding up. So long as you don't finish your move in an enemy's line of sight, tumbling does not subject you to reaction shots made by guarding enemies.

## Whatever Actions

**Equipment Use:** On your turn, you may use an action to set up or interact with a piece of equipment in your inventory, such as a portable wall, a drill, or a multi-tool.

**Extinguish Fire:** If you ever get lit on fire, you can spend n action to put yourself out. You should probably do this as soon as possible.

**Reloading:** As defined in **Combat III: Using and Loading Weapons**, you will need to reload your weapons quite often. This can require multiple consecutive actions if the weapon has the **Slowloader** trait, but normally it just takes one.

**Stabilizing:** When your teammates are incapacitated and speeding towards death, there's no reason to throw in the towel prematurely. As mentioned in **Character Condition II: Incapacitation and Death**, all you have to do is stand adjacent to them and spend a action to stabilize them, which will keep them from death but nothing else. Maybe throw in a reassuring pat on the back while you're there.

**Picking up an Object or Person:** If you ever need to pick up a discarded weapon, unconscious person, or other object, that will cost an action. It does not cost an action to drop or throw it again; but as mentioned in **Character Condition II: Incapacitation and Death**, carrying an incapacitated person will impede your movement.



## Combat VII: Weapon Traits

Today, many weapons have rare or special properties, owing to everything from unorthodox design to happy accidents in manufacturing. Distinctive qualities such as these—known as **Traits**—can fundamentally alter the way a weapon works. While certain weapons may have special traits that are wholly unique, there are a number of traits that can be found in multiple models, from multiple types of weapon. These traits, in addition to the size classes and types mentioned in ‘**weapon characteristics**’ on page 19, are listed and described below for easy reference:

### Penetration: Pierce: Mesh, Ceramic, Plasteel, and Special

**Pierce: [X]:** Pierce is the ability to penetrate armor. Piercing weapons can easily shoot, slice, or crush through the material indicated in the trait’s name, and all those weaker than it. This makes piercing weapons invaluable against heavily-armored or shielded enemies. However, piercing weapons can only pierce small amounts, and will be stymied by larger concentrations of material: piercing weapons can still be foiled by clever use of cover or shields.

Piercing weapons ignore enemy armor, and can damage their target’s health directly. Their damage cannot be negated by armor, even if they do less than ½ their target’s current armor value. Piercing weapons can only pierce the material indicated in the trait’s name, or weaker materials. Weapons with **Pierce: Plasteel** can pierce **Ceramic and Mesh**. Weapons with **Pierce: Ceramic** can pierce Mesh. Weapons with **Pierce: Mesh** only pierce mesh.

### Attack Properties: Artillery, EMP, Guided, Laser, Radiation, Super Long Range

**Artillery:** In this day and age, you don’t need to see someone to kill them. Weapons with the artillery weapon **trait do not require you to have a direct line of sight** to your target: they can hit anything to which a straight line can be drawn, unless a roof is in the way. All you coy types, you can tell what is and isn’t underneath a roof, don’t be jerks about it.

**EMP [X]:** Weapons with this trait exude a powerful electromagnetic force which can scramble communications, cut power, and disable augmentation. When a target is hit by a weapon with the EMP trait, they **instantly lose all effects** that would be granted to them by augmentations.

This effect lasts until the end of the encounter. Additionally, anyone affected by an EMP will take an instance of X damage **directly to their health** for every part of their body that has 2 or more augmentations installed on it. If a weapon with this trait is used against a wholly robotic enemy, they take 2\*X damage directly to their health.

**Guided:** As artillery is to regular attacks, this is to artillery. Weapons with this trait do not need a line of sight to their target, and ignore cover at all times.

**Laser:** Laser weapons excel at stripping armor away from enemy targets, but lack the raw damage output of ballistic weapons.

Laser weapons **do not** suffer penalties from high wind or rain.

Laser weapons **always** damage armor, bypassing ordinary damage negation and chip damage. Laser weapons increase their damage dealt against a target by 1 for every turn spent attacking said target. This bonus dissipates if the owner goes a turn without attacking said target, for any reason. Laser weapons **cannot damage a biological target’s health**, but can still damage machines.

**Nonlethal:** weapons with this trait rely on blunt impact, electric shocks, or knockout gas to pacify their targets without killing them. If a target’s health is reduced to 0 by a weapon with this trait, they are merely knocked out instead of killed. They are incapacitated, but do not need to be stabilized.

**Radiation:** What’s that green glow? Weapons with the radiation trait use bursts of gas and energy to melt the flesh (particularly the genitals) of enemies. Weapons with this trait **cannot** damage shields or a SPC Barriers, but always have **Pierce: Plasteel**.

**Super Long Range:** Sometimes it’s not enough to shoot your enemy through the scope of a sniper rifle: sometimes you have to shoot them with a building-sized cannon using positional data from a radar station halfway around the world. While Super Long Range weapons aren’t *quite* intercontinental, they’re pretty close. Their range increments increase by **twice the shot’s range up to that point**, so that they have a maximum range of **nine times** their effective range! The penalty for exceeding effective range is reduced to -2. For example, a weapon with an effective range of 2 would have a first range increment of 6, firing at a -2, and a second range increment of 18 firing at a -4.

## **Concealability: Dead Giveaway, Notorious, Stacking, Suppressed, Silent, Undetectable**

**Dead Giveaway:** Weapons or items with this trait are so conspicuous and dangerous that simply owning one is enough to bring attention down on you. If you have an unconcealed weapon or item with this trait, lawmen will automatically pass their Suspicious Person Roll if they see you. Unless otherwise noted, **all Long Weapons have this trait.**

**Stackable:** Items with this trait are, like bananas, often found in bunches. You may carry up to 10 of them in a single inventory slot.

**Suppressed:** Weapons with this ability produce muffled zaps and gunshots. The audible range of suppressed weapons is only five squares; however, they may not shoot outside their effective range.

**Silent:** Silent weapons are like suppressed weapons, but one step beyond: they produce virtually no noise, and can only be heard by creatures standing within a square of the character using them. All **Melee** weapons are silent unless otherwise noted.

**Undetectable:** Undetectable weapons are made of plastic, aluminum, or some other material that doesn't trigger readers. Weapons with this property won't set off metal detectors, and won't show up on X-rays. They're invaluable on stealth and infiltration missions.

## **Drawbacks: Disposable, Heavy, Limited-Use, Recoil, Mounted, Slowloader, Spin-up**

**Disposable:** Some weapons aren't made to last. Like, at all. Weapons or items with the "disposable" trait are removed from your inventory once you have spent their CAP, and must be purchased again.

**Heavy:** Some weapons are just too large to use elegantly. Heavy weapons cannot be fired in the same turn that their wielder takes a move action. This cuts both ways—a character cannot move and *then* fire a heavy weapon; nor can they fire a heavy weapon, and then move to end their turn.

**Limited-use [X]:** Limited-use weapons have a low number of magazines, charges, or whatever else they take for ammunition. They only have X magazines and may not be loaded more than that many times per job, counting the initial load. Specially-purchased ammunition may still be loaded into limited-use weapons, where applicable. They regain all their uses between jobs.

**Mounted Weapon:** Weapons with the Mounted Weapon trait are affixed to a solid object: usually a tripod, mechanical arm, or something else very sturdy. Mounted Weapons are placed on the map as tokens, usually before a job commences. They may be used without having to pick them up and equip them, but cannot be removed from their starting position unless specially noted. They cannot critically fail, and do not suffer penalties from the **recoil** trait.

**Recoil [X]:** That is to say, this trait, here. Any weapon with this trait kicks like a mule (No offense to any mules in the audience). They're difficult to keep straight, and impose a -X penalty onto any shot made with them. However, this penalty can be offset by spending an action to aim the shot. The recoil penalty only comes back into effect after the shooter moves, for any reason.

**Slowloader [X]:** Weapons with this trait require sustained attention to reload. Whenever you want to reload a weapon with this trait, you must spend X consecutive actions to do so.

**Spin-up [X]:** Weapons with this trait rely on internal generators or moving parts to operate. They must spend time revving or warming up before they can be used. Before a weapon with this trait can be fired, you must spend X actions spinning it up. These actions may be made over multiple turns, and do not have to be consecutive. If you ever go one turn without spending at least one action spinning up, you must start again.



## Extra Damage: Automatic, Blast, Cone, Shotgun

These traits all dramatically increase the damage output of a weapon. If a weapon has multiple of these, they always apply in the order **Automatic, Shotgun, Cone, Blast**.

**Automatic [X]:** Automatic weapons use complex firing actions to fire a large number of projectiles quickly and accurately. When you attack with an automatic weapon, you **must** make **X shots**, with each having all weapon traits applied.

Multishot penalties are applied per burst, rather than per-shot—ergo, attacking with an Automatic 2 weapon fires 2 shots with no multishot penalty; but attacking twice would fire 4 shots with the normal penalty. These shots can critically hit and critically fail like any other attack, and each shot drains CAP as normal. If your CAP is reduced to 0 in the middle of an automatic attack, it ends immediately.

**Blast [X]:** Weapons with the blast trait release explosive force upon impact—these include hand grenades, rockets, or trip mines. On impact, a blast weapon's damage is spread over a number of squares on the grid, instead of a single target.

Upon a successful attack, every token within X squares of the attack is affected; but characters in cover from the attack take none. Blast weapons may harm friendly targets as well as enemies.

Multi-shotting with blast weapons incurs double the normal penalty. Blast weapons may target empty squares as well as enemies.

**Cone [X]:** A weapon with the **Cone [X]** trait disperses flames, chemicals, or other payloads over a wide area. When you fire a weapon with the cone type, draw a straight line from you to your target. Every target—friendly or enemy—within Y squares on either side of this line is hit by an instance of this weapon attack. Y starts at zero and increases by one every X squares down the line, meaning the area of effect is always wider at the end.

Targets in multiple spaces covered by the cone do not take extra damage. Targets in cover from every point which would damage them are unaffected by the cone. Cone weapons cannot target anything outside of their effective range, but may target empty squares. If all this seems like too much trouble, just use a cone-shaped template from your tabletop wargame of choice.

**Shotgun [X]:** Weapons with the Shotgun trait fire pellets, flechettes, or other scattering projectiles. When you hit with a shotgun, roll a dX, where X is the rating of this trait. Your attack does that many instances of damage, with all traits applied. This means, for a weapon with DAM 5 and Shotgun 4, you'd roll a d4, and could deal up to 20 damage!

Shotgun is applied separately on every Automatic shot. Shotgun does not apply if your target is outside of the weapon's effective range.

## Firing Actions: Assassin, Idiot-Proof, Simple, Targeting Software

**Assassin [X]:** Weapons with this trait are small, delicate, and require their target to be unaware of them. Weapons with this trait can be operated using **stealth** instead of murder. Additionally, if a weapon has **Assassin [X]**, it does X additional damage whenever it makes a successful sneak attack, which is multiplied by the sneak attack bonus as normal. Both of these traits **only apply** while the target is unaware of the wielder's presence, as defined in **Sneaking IV: Sneaking and Combat**.

**Idiot-Proof:** It turns out, some things are so easy to use that it's literally impossible to fuck them up. Equipment with the Idiot-Proof trait does not require a roll to use unless otherwise noted. This trait does not apply if a piece of equipment is used in a way which would inflict a penalty of any severity.

**Simple:** Simple weapons are primitive designs, and don't require much skill to use. They are the only weapons that can be used without disrupting inkflow, and are as such commonly favored by artistically-inclined operators. Weapons with the Simple trait **do not** cause casters to lose IP upon equipping them, and may be used to attack by rolling **Artistry** instead of Murder.

**Targeting Software:** Weapons fitted with targeting software use complex algorithms and motion sensors to predict the trajectory of their targets with...moderate degrees of success. A weapon with targeting software may be fired using the shooter's **hacking** or **hardware** skill, albeit at a -4 penalty. Due to the complexity of these devices they **may not** be fired by any other means.

## Lingering Effects: Bleed, Burn, Contaminant, Fear, Poison

**Bleed [X]:** Sometimes your inside parts forget where they're supposed to be. Bleeding damage is nastily persistent, but fairly easy to overcome. Whenever someone is bleeding, they take 1dX damage; and on the following turns, X becomes the amount of bleeding damage they took the previous turn, minus one. So, if someone rolls a d8 and gets a 3, on the following turn they will roll a d2.

**Burn [X]:** It burns, burns, burns. Burning damage is the most powerful form of damage-over-time—it actually *increases* over time, and can very easily kill someone outright. Whenever someone is set on fire, they take 1dX damage; and at the end of their following turns, they take 1dX damage plus however much burning damage they took on the previous turn. Fortunately, Burn is also the easiest breed of damage to get rid of—all you need to do is spend an action to extinguish yourself. If someone is burned multiple times, they take damage from all and can be removed with a single action.

**Contaminant [X]:** Some weapons leave a mark that really lasts. Weapons with the contaminant trait leave a marker at their point or points of impact for [X] turns. Anyone who moves through said area before the contaminant expires will take damage equal to the amount of damage that would have been inflicted by an attack by said weapon, including all traits and modifiers of all kinds.

**Fear [X]/[Y]:** Holy shit! Weapons with the Fear [X]/[Y] effect inflict a penalty of [X] to any voluntary rolls their target makes. If multiple instances of the Fear effect are applied, this penalty stacks, too! If the source of the Fear effect is incapacitated or killed, the fear effect automatically ends!

When the Fear effect is applied, and at the beginning of each turn afterwards, the target may make a grit roll at a penalty of [Y] to negate the effects of all fear effects on them! Additionally, they may spend an action to make another roll to try and dispel the fear! Neither of these rolls take the [X] penalty, and the [Y] penalty does not stack—only the highest one applies!

**Poison [X]/[Y]:** Poison in your veins! Poison is the most reliable way to inflict damage-over-time upon your opponent, because it's the hardest to get rid of. Poison does 1dX damage directly to its victim's health each turn, and can only be eliminated by using the Cleaner item. Poison stops by itself after Y turns have elapsed.

## Powered Equipment: Burdensome, Invulnerable, Mighty, Uplink

**Burdensome:** Armor and equipment with this rule is so large and heavy that it is hard to run with it, and it often needs of inlaid servo-motors just to walk around in. While wearing Burdensome armor or equipment, you may never use both of your actions in a turn to move. The effects of burdensome do not preclude a character from using additional actions conferred to them from ink, augments, or other sources to move multiple times in a turn.

**Invulnerable [X]:** Armor with this rule is so remarkably well-built that it's nearly bulletproof. Whenever someone with the Invulnerable [X] trait takes **armor** damage, reduce the damage dealt by [X] before resolving its effect. Invulnerable **cannot** protect you or reduce damage from any attack that hits your health, shield, or any SPC barriers you have. The effects of Invulnerable [X] dissipate as soon as its wearer's armor is broken. If multiple instances of Invulnerable are present on a character, only the strongest one applies.

Invulnerable does not apply to chip damage.

**Mighty [X]:** Armor with this rule makes use of inbuilt servo-motors to augment the wearer's strength, and can form a devastating compound effect with other augments. Items with Mighty [X] add [X] points of damage to the wearer's unarmed damage.

**Uplink:** Some armors, weapons, or other devices are so advanced that they must be directly connected to your brain stem to function. Uplink, uniquely among equipment traits, has two variations: **Uplink (I) [X]** and **Uplink (O) [X]**. These are representative of input and output, respectively. If you wish to equip a weapon or item with Uplink (I) [X], you must have a currently-equipped augment, trait, or item that has an amount of Uplink (O) that is equal to or higher than the Uplink (I).

## **Peculiarities: Bomb, Drug, Mod, Plan, Surgical**

**Bomb:** Bombs are not toys. They are big nasty things that can really fuck up any given map. An item with the bomb type can only be used once, and its price may be affected by the buyer's **Explosives** skill.

**Drug:** They're not cool or glamorous or kid stuff. An item with the drug type is used to modify a character's abilities. It can be only used once, and its price may be affected by the buyer's **Chemistry** skill.

**Mod:** If you want your weapon to work a little differently, you can use these. An item with the mod type does not occupy an inventory slot, and modifies the function of a weapon, as indicated in the modification's ghdescription. Their prices are affected by the buyer's **Weaponsmithing** skill.

**Plan:** Sometimes on-site procurement will only get you so far. For complex and high-risk operations, you need inside men and high-value intelligence. Items with the Plan type modify something about the enemy or security deployment on your next job. They do not occupy an inventory slot. They can only be used once, and their prices are affected by the buyer's **Mastermind** skill.

**Surgical:** The reason you call them medical professionals instead of medical amateurs is because it requires a fair bit of education to do it properly. Items with this trait provide valuable healing functions that cannot be duplicated by the field medic skill. Whenever an item with the surgical trait is used, the user must roll surgery to determine whether or not the item takes effect.

## **Size Classes: Compact, Short, Long, Equipment, Head, Boots, Torso**

You already saw these earlier, back in **Combat I**. But we're including them here anyway for easy reference. Just to make sure.

**Long:** Weapons with this trait require two limbs to operate properly—they encompass rifles, swords, axes, and heavy weaponry. Long weapons occupy the Long Weapon space in your inventory, and are best used as direct assault weapons.

**Short:** Weapons with this trait require only one limb to use properly, and are generally less powerful than long weapons. They occupy the Short Weapon space in your inventory, and are usually used as sidearms or in close quarters.

**Compact:** Weapons with this trait are so small that they can be easily tucked into your clothes or affixed to your joints. They occupy the Compact Weapon space in your inventory, and are generally only employed as holdout weapons.

**Equipment:** Weapons or items with this trait occupy the Equipment slot of your inventory.

**Head:** Weapons or items with this trait occupy the Head slot of your inventory.

**Boots:** Weapons or items with this trait occupy the Boots slot of your inventory.

**Torso:** Take a wild fuckin' guess.

## **Damage Types: Arrow, Bullet, Chemical, Doohickey, Energy, Melee, Warhead**

Damage types do not, by themselves, confer any particular effect. However, certain effects from other items or abilities may affect or interact with weapons of a specific damage type—for example, the *Ethereal Regis* doodle has an IP cost which depends on the type of projectile being blocked at any given moment. If a weapon has a damage type, it will be listed after its size. If something does not have a type, you shouldn't be hitting people with it.

## Sneaking: What you Need to be an Assassin or Second Story Man

Plenty of operators out there will tell you that the best way to do your job is to never even be seen. There are plenty of thieves, assassins, and television repairmen who know this to be true; and even if you're not one of them, every Operator should at least understand the basics of stealth. Because of the nature of this game, you're going to be avoiding detection more than you're going to be doing the detecting—but make no mistake, enemies can get the drop on you too, and you need to know what to do to keep that from happening.

### Sneaking II: Taking Turns While Sneaking

Sneaking works, in many ways, like combat. You take turns, you make actions, you roll dice, and hopefully you come away with a lot of money. Like combat, sneaking is divided into encounters, rounds, and turns; there are, however, a few slight differences in how it all works.

- **A sneaking Encounter begins** when at least one character attempts to avoid the attention of any other. This should generally be sorted into the “tension” mood, and held as a distinct encounter from any combat which occurs thereafter.
- **It ends only** when the sneaker is revealed, or combat is engaged anywhere on the map. At the GM's discretion, small combat engagements between unrelated parties—such as a fistfight in the distance—may occur without disrupting the sneaking encounter.
- **During a round**, players take their turns as normal, but all NPCs resolve their actions simultaneously at initiative 1. NPCs may only take their turn when all involved players have concluded their turns.

### Sneaking II: Scrutiny and Senses

There's only so much one person can see; and when you're working, awareness is everything. In a game of Toonpunk, characters can't see everything going on around them the same way you can on the board. They can be distracted, or fooled by camouflage. Toonpunk characters can only see hidden objects if they are within their **scrutiny range**. A character's scrutiny range is a number of

squares equal to their perception, and stretches in all directions. More than this, Characters who are on the lookout for other characters will only find them if their quarry passes within range of one of their **senses**. Characters can have any number or combination of senses, and each works differently:

**Sight:** Sight will reveal any enemies within your scrutiny radius, but is completely ineffective against enemies who are in cover, above you, invisible, or otherwise out of view.

**Hearing:** Hearing works on enemies who are out of view, but only stretches to the halfway point of your scrutiny radius and only works on enemies who are moving.

**Extrasense:** Extrasense is a catch-all term for psychic senses, enhanced smell, or other powerful detection abilities. It reveals enemies in your scrutiny radius, full stop—including those who would otherwise be Untargetable. It should be used only for powerful and elite foes who cannot be surprised.

Bearing in mind that enemies and other players have scrutiny radii of their own, it is vitally important to figure out where they end. This may be accomplished by making a perception roll, and targeting a specific person: if the roll succeeds, the GM must disclose where their detection radius ends; however, they do *not* have to disclose what senses the enemy may or may not possess.

Characters with 0 stealth can still remain undetected as long as they avoid the enemy's sensory radii; but characters with -1 are discovered as soon as the GM feels appropriate.

### Sneaking III: Stances and Distraction

If you happen to find your way into an enemy's scrutiny radius, you're in trouble—but that's no reason to stick your hands up and get shot. There are a number of ways to get around a watchful enemy, if you know how. You can make use of several **stances** which let you bypass or lessen the effects of their senses. These are:

**Normal:** This is the standard stance and speed, free of any subtlety—nothing more than the same run you use during jobs. You move your full move speed in this stance, and are detected whenever the GM says you are.

**Creeping:** Creeping is the easiest way to stay hidden. This is measuring your footfalls to ensure you don't make much noise. While in this stance you can only move a number of squares equal to your stealth **OR** athletics score, whichever is lowest. You will be seen if you enter an enemy's **sight**. If you would move into or through an enemy's **hearing**, you may roll stealth to avoid being heard.

**Crawling:** Crawling is the sneakiest, and slowest, available position. It's a favorite of soldiers and spies, but it carries with it a few dangers. While Crawling, you may reduce enemy's sight and hearing radii by half your stealth score; but only as it applies to you. Unfortunately, while crawling you can only move  $\frac{1}{4}$  your normal speed.

Sometimes, though, you don't need to worry yourself with crawling, or stealth rolls. Sometimes enemies may be distracted, and easy to avoid. Enemies can be distracted by almost anything, at the GM's discretion: bright lights, loud noises, something interesting on a nearby television, etc.

If a character is distracted, the relevant sense is disabled until the distraction is removed—for example, someone listening to loud music or working in a noisy area might have their hearing sense temporarily disabled, while someone in a dark room might be unable to see.

It is still possible to be detected by someone who has been distracted if you manage to be even more egregious than whatever is distracting them. For example, someone looking at a distant object will see you if you pass between them and said object.

Anyone who is **hacking or engaged in combat** generally counts as having both their eyes and ears distracted. This means it is easy to avoid the attention of fighting enemies.

## Sneaking III: Sneak Attacks

Sometimes you can't take a guy in a stand-up fight. Lucky for you, if you land an attack on an enemy who was previously unaware of your presence, it does three times the damage it normally would.

Nuff said.

## Sneaking IV: Sneaking and Combat

Sometimes, you may have to conceal yourself from someone who has been alerted to a hostile presence. When this happens, your job will become significantly more difficult—but by no means impossible. If combat has begun in your vicinity, and you are undetected, you must roll initiative as normal; but you are not automatically drawn into the fighting. On your turn, you may continue to sneak with the normal stealth rules applying, save some minor exceptions:

**Enemies who have been, by any means,** alerted to the presence of a hostile party cannot be sneak attacked as normal: they do not receive extra damage from unseen attackers, and do not count as viable targets for weapons with the **assassin** trait. However, they can still fall prey to, and each of these exceptions do not apply to, reaction attacks (see '**Guard**' on **page 25**). This means that alerted enemies can only be sneak attacked if they blunder into an ambush set by a guarding enemy. Scrutiny, stances, and stealth rolls are all factored in normally during combat.

If you are ever detected by **one** enemy, any other enemy who can draw a line of sight to you **also** detects you. After this, it is still possible (but challenging) to return to concealment. If you manage to break all enemy lines of sight to you, you automatically and immediately return to being hidden; but for the next **3 turns, you suffer a -3 penalty** to any stealth rolls you happen to make against any enemies who had previously seen you.

# Hacking: How to Conquer Computers and Twist Technology

## Hacking I: Overview

In the world of Toonpunk, electronics are nearly omnipresent. Whoever controls the electronics, controls...well, maybe not the *whole* world, but a decent-sized chunk of it. Hackers are indispensable for recon, infiltration, and combat: they can remotely disable or control weapons, cameras, augments, and dozens of other things besides! Suffice to say it is absolutely imperative that you have at least a working knowledge of hacking. Fortunately, it's simple enough to understand.

Hacking requires a combat action. However, instead of using a conventional weapon to shoot people, you use a futuristic cyber weapon to hack things! Any item that is tagged as a **Computer** may be used to hack into objects.

While hacking, you may choose to interact with any object which is currently within your computer's range—this is called your **Area of Influence**. There are certain pieces of equipment which can extend your area of influence beyond your computer's range. Even if you do not have a ranged computer, you automatically have influence over anything to which you are adjacent—this is called **physical access**.

When hacking, you may attempt to claim any number of wifi-enabled objects in your area of influence, or run as many executable programs as your computer can process. To learn more about executable programs and processing costs, consult **Hacking III: Executables**, on the next page.

All computers have a specific amount of **processing power**, denoted in their description, with which they can run executables and manage hacks. Additionally, you gain an extra amount of processing equal to half your Hacking score. For example, if Roberto the Robot has a computer with 3 processing power, and a hacking score of 6, he has a total of 6 power.

## Hacking II: Objects and Hacking Clashes

In Toonpunk, all hackable objects fall into one of two categories: **Neutral** or **Allied**.

**Neutral** objects are electronics that are not currently under protection or assault by a hacker. They may help or hinder you, depending on their design; but they will not mount any resistance in the event that you decide to hack them. To take control of a neutral object, you merely need to move it into your area of influence, and then make a successful hacking roll. Neutral objects include things like unsecured networks, cameras, or computers. These are common in low-security areas like ghettos, wastelands, or walk-in restaurants.

**Allied** objects are under the control of another user. Once a neutral object has been claimed by a hacker, it becomes allied with whoever took control of it. They are then able to use it as they please—for example, they might receive footage from a camera, or reprogram a robot to fire on its former owner. Most objects are allied by default.

All hackable objects have a **Processing Power Cost** associated with them. While you control an object, you must reduce your computer's processing power by that much. This means that a hacker can only ever control a limited number of objects at once. If an object's PP Cost would reduce your computer's available processing to less than 0, you may not take control of the object (even if it is neutral) or defend it if it is allied with you. You may at any point forfeit control of an object, and instantly regain any lost processing power.

Whenever a character tries to usurp control of an allied object, they must roll a **Hacking Clash**. A hacking clash is a battle of skills and wits waged over keyboards and connections—at the end, one hacker will gain (or keep) control of the contested object, and the other will be left out in the cold. Hacking clashes are identical to normal clashes, with the following exceptions:

- **When a hacking clash starts**, the attacker and defender **both** must expend the target's processing cost; if the defender cannot or does not want to pay the object's cost, then the attacker immediately seizes control of the object. The defender cannot evade or ignore a hacking clash the same way as a normal clash.

- **During hacking clashes**, both opponents roll a number of D10 equal to half their hacking score, instead of half their murder score.
- **You can freely move** and perform other actions while in the middle of a hacking clash, but remember that Hacking is an attack action.
- **If someone would ever roll 3** fewer dice than their opponent, they immediately lose the clash.
- **You may spend** extra processing to gain extra dice in your hacking clash, at a rate of 1 extra die per point spent. Spent processing power is returned to you at the start of your next turn.
- If you win the clash, you gain complete control of the contested object. Awesome.

## Hacking In Stealth

During tension or downtime scenes, GMs may opt to treat items which would normally be allied as neutral instead. During downtime, this may represent low-security electronics, like cell phones or consumer augmentation; and during tension scenes this may represent objects which have, but have not activated, cybersecurity measures. This allows hackers to perform recon and sabotage during peaceful scenes, without having to engage the enemy in hacking clashes.

## Hacking III: Executables

Despite what the movies would have you believe, there's a little bit more to hacking than slamming on keyboards and whispering "I'm in" every few minutes—that's the lion's share, mind you, but not *all* of it. Some of the finer points of cyberwarfare can only be accomplished via the employment of dedicated executable programs, which can be used to perform a vast variety of functions. Like most things, executables have a unique stat block.

Executables, like other items, have names, descriptions, functions, and pricetags. However, they also have a **Processing Cost** attached to them. Processing cost is a measure of how difficult the program is to run. Whenever you run an executable program, you must expend that much of your computer's processing power; and if you cannot pay the cost, you cannot run the program.

Fortunately, unlike claiming objects, the processing costs of executables are not persistent: it lasts only for a single turn, and at the start of each turn you automatically regain any processing power which you had spent on running executables.

An executable's completed profile looks like this:

### **Nudes.exe (\$25000000)**

#### **Program, Processing cost 5**

Nudes.exe warps reality to display authentic nude photographs of anyone you point it at.

A complete list of available executables and other hacker items can be found starting on page 80 of this manual.

## Hacking IV: Things You Can Hack

This next section is a complete list of things which hackers can control, along with an in-depth description of their effects. It will behoove you to familiarize yourself with this: not only are they valuable tools for you and your teammates, but they can be turned against you by enterprising enemies.

### **Computer Consoles (PP cost 0)**

Most security systems are controlled by high-tech security consoles. They're so high-tech, in fact, that you can **only hack them if you have physical access**. Computer consoles are often "attached" to certain things such as doors, cameras, or vehicle steering systems. Anything that is attached to a console **begins the game allied with the console's controller**, and will default back to that state if they are ever neutralized. Computer consoles can control **any number of attached systems** at no processing cost, but **cannot** be used to hack anything else.

### **Wireless Cameras (PP Cost 2)**



Wireless cameras are a very common security measure. They relay vision of everything within 8 squares to a nearby computer. They begin the game allied to whichever faction owns said computer; and if they are neutralized, they will default back to that state. Upon being hacked, a wireless camera will begin **looping** itself: playing the same footage of an empty room over and over again. It will stop relaying images to the camera's owner. Wireless cameras may be distinguished from wired cameras by the green wireless receivers on their casing.

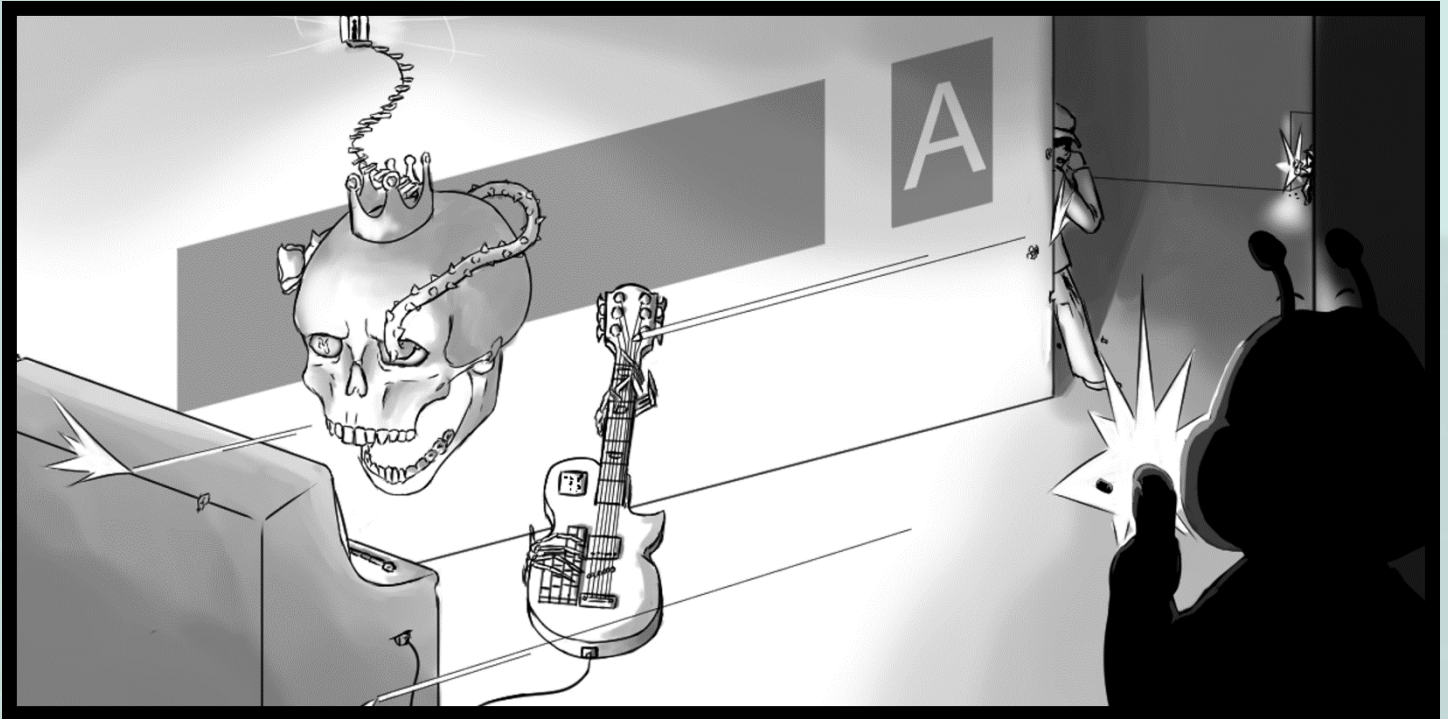

### Electronic Doors (PP cost 3)

These doors, marked with bright blue lines, can be opened or sealed shut. A neutral electronic door stays shut, but an allied electronic door can open or close at the owner's discretion.

### ID Tag (PP cost 1)

ID tags are weapon security measures that prevent them being used by thieves. A neutral ID tag will deny use of the weapon to anyone except its owner. An allied ID tag can be made to deny its owner as well, rendering the weapon useless; but ID tags cannot be used to make it usable by new users.

**Editor's note:** This means that, inevitably, at least one game of Toonpunk will feature a hacker who stabs one or more teammates in the back by shutting off their guns at a critical moment. This is a completely legal maneuver.

**Do not trust your hacker, they are all liars.**

### Subdermal Augments (PP Cost 1)

These augments generally rely on precise nanotechnology and other things which require some form of wireless communication. Subdermal augments can be shut down, to deprive the owner of their effects; but the victims suffer no other harm.

### Technological Ascender Augments (PP Cost 4)

These augments plug directly into the implantee's brain, and if hacked can **instantly incapacitate the owner**. Even if the owner is revived, the Ascender will be disabled for the rest of the encounter.

### The Sun (PP Cost 4)

Can be turned off and on again.

### Items With the "Computer" Type (PP Cost 3)

Personal computers such as the ComDom or Blacktop are what most hackers will use against you—which is something you can use against *them*. Items with the **computer** type begin the game allied to their owner; but if they become allied to anyone else, the new owner may completely deny access to the device as long as they maintain influence over it. For obvious reasons, a computer's PP cost does not apply to the person who owns it at the start of the encounter. That would be silly.



# Character Creation

## Character Creation I: The Idea

The very first thing you do when creating a character is come up with the idea behind them. It's about as simple as it sounds: you have a rough outline in your head, you put it onto paper, and then you use the rest of this section to figure out how to represent that idea within the mechanics of the game. You may already have some idea of what you want your character to be, and you might even be able to indicate a published work of fiction as a clear inspiration: maybe you're playing a character similar-to-but-legally-distinct-from a popular superhero, or fantasy icon. Since this game is about imaginary creations coming to life with basically no restraint, you can get creative. While there are plenty of rules regarding what your character can *do*—you've seen them already—there's not any real limits on what your character can *be*. There are, however, some guidelines we encourage you to consider.

**Your character should be a sapient creature** capable of making its own decisions. This may include such things as humans, robots, anthropomorphic animals and furniture, etc.

**Your character should have a reason to commit crimes.** After all, if they didn't they wouldn't really have much to do with this game. Your character should be greedy, voracious, sadistic, downtrodden, disenfranchised, under duress, or something else that would cause them to take up the criminal lifestyle in pursuit of money.

**Your character should be able to be adequately represented by the rules in this book.** During a toonpunk game you should under no circumstances attempt to roleplay an eldritch monstrosity beyond the comprehension of man, or anything else which cannot function within the mechanics in this manual. Superheroes, demigods, and other remarkably powerful but comprehensible creatures are still perfectly acceptable—after all, being in the world of Meatmen has brought even the most powerful Toons down a notch.

Beyond these guidelines, there's just a few things you need to keep track of before you're ready to start cracking vaults with the best of them. You will find a character sheet template at the end of this

book; but before you fill that out, take a moment to contemplate these questions:

**What is your character's name?** Simple enough. The name can be complex, or simple, or whatever else you want. But, choose it wisely because you only choose it once!

**What does your character look like?** Take special care with this one: there's a big portion of the sheet dedicated to a portrait of your character, and you'll need to be able to draw one, or have a buddy draw one for you...Or just filch one off the internet and use that instead. Don't worry, I won't tell.

**How does your character act and feel about the world around them?** Make sure to read any information about the world your GM provides you—this could form important sticking points in your character's moral or political beliefs. And if you're thinking about skipping all that, this time I *will* tell.

**What does your character contribute,** as a criminal? A good way to set about deciding what role you want to play is to figure out what part of the criminal enterprise sounds the most appealing to you. Do you want to be hired muscle, toting a shotgun and a hammer? Do you want to be a suave trickster, a daring burglar, or a genius hacker? Consider all of these, and collaborate with your friends to get a head-start on establishing a useful group dynamic.

**What are your character's stats?** Oh, wait, you mean we haven't told you how to figure that part out yet? Well, turn the page, friend. It's right there!

If you're having trouble coming up with any part of a character—a backstory, a design, or their stats—you will find several player character templates at the back of this book, which you can use as liberally as you like for inspiration, or just steal them bodily.

**What if your character doesn't really make sense?** What if your character is like, a car, or a pony, or something else that shouldn't be able to wear body armor and use guns? Well, a not-so-average Joe once said "It's magic, it doesn't have to make sense." At the time, I thought he was an asshole—but then again, he made thousands of dollars editing my favorite comic magazine, and I'm writing this manual in the dumpster behind a PF Chang's, so...listen to Joe, kids.

## Character Creation II: Character Attributes

Character Attributes are, just like your character's other details, an incredibly important aspect of a TP game; perhaps *the* most important aspect, really. Your Character Attributes define your abilities in the field, and using them properly can be the difference between world domination and an unmarked grave. Each attribute is graded on a scale of **-1 to 10**, where -1 represents a clinical inability to succeed even slightly, and 10 represents world-class aptitude—a character with Grit 10 could potentially withstand being shot a dozen times, while a character with Hacking -1 can barely even use a computer. Skills are determined by the points you invest into them at the start of the game. **All attributes start at 0, and you have 36 points to divide amongst them**—1 point allows you to raise the value of any given attribute by 1. You can reduce a skill to **-1 in exchange for another point** to spend on a separate skill, at the price of tragic incompetence. The Skills are, as follows:

**Grit:** A measure of how rootin-tootin-rough-and-tumble you are—that is to say, your resistance to physical trauma, intense conditions, and other forms of bodily harm. For every point you have in Grit, your maximum health increases by 1 point. Characters who have -1 grit have a measly 1 hit point—which means they can be incapacitated by any amount of damage. Be careful!

**Athletics:** A measure of your physical prowess, more specifically your strength and speed. Athletics is rolled when running, climbing, jumping, ducking, lifting, or other physically strenuous activities. Athletics also determines your move speed: on the map your movement speed is equal to your athletics skill—or 3, if your athletics is 2 or lower (even fat people can jog a little). Characters with -1 athletics suffer from some form of crippling degenerative condition, and cannot move at all. You'd best hope someone is willing to carry you.

**Hacking:** Your skill with computers. This is rolled when slicing, rewiring, and otherwise doing computery things. For information on what hacking can do, see the **Hacking** section of the manual on **page 34**. Characters with -1 hacking are incapable of performing even the most elementary computer operation. Even attempting to do so triggers an effect of the GM's choice. Don't try it.

**Stealth:** Your ability to move silently and unseen. Stealth is rolled when attempting to evade detection, or carry out some sleight of hand. For more information on the fine points of stealth, see the **Sneaking** section of the manual on **page 32**. Characters with 0 sneaking can still avoid being seen under the right circumstances; but those with -1 are revealed as soon as the GM feels like it.

**Murder:** Your murder skill is rolled when shooting, stabbing, punching, strangling, or really doing just about anything else that could injure someone else. For the precise ins and outs of the ol' in-out, see the **Combat** portion of the manual on **page 19**. Characters with -1 murder are the actual worst at fighting, and any attempt to do so results in them taking 2 damage directly to their health.

**Acting:** A measure of your ability to put on airs—to persuade, charm, seduce, intimidate, haggle, and other such actions that require you to affect a convincing presence. Anyone with -1 acting instills a sense of revulsion in anyone who sees them.

**Hardware:** A measure of your affinity with mechanisms and mechanical parts. Hardware is rolled during any skilled interaction with machinery. Characters with -1 hardware will invariably fail this action and take 2 damage directly to their health.

**Perception:** How well you notice the little details. Perception determines the length of your **senses**—see '**senses**', on **page 31**: your **sight** is a number of squares equal to your perception, your **hearing** is equal to half that. Furthermore, Perception is rolled at the GM's behest to discover traps and other hidden things. People who take -1 in this are blind and deaf and cannot sense anything. Don't do it.

**Artistry:** Your character's affinity with and the ability to manipulate The Ink. This affects how well you can use doodles, if you are the sort who does such things. For more information on what Artistry does and how it works, see **Doodles** on **page 20**. You can't take -1 in this.

**Nonsense:** Your character's ability to overclock their bodies and seize their destinies. For every point you have invested in Nonsense, your character may store one additional Power Burst, up to a maximum of five extras. For more information on Nonsense and power bursts, see **Power Bursts** on **page 12**. Characters with -1 Nonsense cannot gain or store power bursts at any time, and **can** have power bursts used against them. Pity them.

## Specialties

In addition to the core skills, there are a wide variety of **specialty** skills to choose from. Specialty skills are skills which augment or amplify the effects of other skills, or cover ground which the core skills don't. All characters are afforded **10 points** to spend among any and all of the specialties listed below. Players may spend their core ability points on specialties if they are so inclined, but should be careful doing so: this may leave them weakened.

You **cannot** take -1 in specialty skills.

**Bossyboots:** More charitably known as "leadership skills," the Bossyboots specialty is your character's ability to use their natural charisma to spur others to greatness. For every 4 points you have in the Bossyboots specialty, you may spend one of your actions to boss around a single member of your team that you can see, giving them an extra action that turn. You may do this up to twice per turn. At 10 points in the Bossyboots specialty, you can still only do this up to two times; however, you now need only spend a single action to give both commands. A character can only benefit from a **single** action given through bossyboots each turn, regardless of how many times it is applied to them.

**Chemistry:** The ability to brew and use differently-concocted poisons, drugs, and other gunks of a chemical or herbal nature. The chemistry specialty reduces the black market price of many drugs, poisons, and other related items. The effect chemistry has on a given item will, if applicable, be detailed in the item's black market description.

**Explosives:** A knowledge of and familiarity with high explosives of all varieties. Explosives allows you to place and operate mines, demolition charges, and a variety of similar devices. It additionally reduces the black market price of many of those same items, and increases some of their effects. The effect explosives has on a given item will, if applicable, be detailed in the item's black market description.

**Field Medic:** Your character's ability to treat allies in the field with temporary fixes. Field medics can mend gunshots, lacerations, and burns using topically applies bandages, sutures, and antiseptics. Field medic can be rolled at the medic's discretion, and successful rolls can be used to heal themselves or allies by **half the patient's grit**—so that, for example, a character with 4 health and Grit 5 would be healed for 2 points, up to a total of 6 health.

Field Medic can also be used to operate certain items and weapons. Field Medic can only be used **once on each character** during a given encounter, regardless of how many field medics there are tending to them at any given moment. The effect field medic has on a given item will, if applicable, be detailed in the item's black market description.

**Finance:** Finance is an understated but very powerful specialty, which represents your character's ability to move money around, acquire buyers for stolen goods, and generally navigate the labyrinthine foolishness of the modern economy. Finance is never rolled; BUT for every point you have in finance, the value of any loot you acquire in a mission increases by 1%, up to a maximum of 10%. Finance can only be applied to goods stolen from a job and not anything acquired from or sold to the black market. Finance can only be applied a single time to any given take from a job, regardless of how large it is, how large the crew responsible was, or any other conceivable factor at any point in all of space and/or time.

**Gender Studies:** Allows you to understand and exposit on the representation, politics, and identification of genders.

**Loader:** Big guns—machine guns, rocket launchers, etc—are tricky things. Even if you have more ammo than you know what to do with, sometimes you can barely fit the bullets in the damn thing! That's where the Loader comes in. If you have points in the loader specialty, you can spend any number of actions on your turn to help an adjacent teammate load their equipped weapon. When you do so, roll Loader; and if the roll is successful, you may spend that action loading the teammate's weapon, as though they had done so themselves. Loader actions may be used as reactions from guard mode, if an ally ends a movement adjacent to you.

**Lockpicking:** When you need a door open, there's no better skill to have than lockpicking. This specialty can be used to open locked doors, electronically locked doors, alarmed doors, and sturdy doors without triggering alarms or relying on specialized tools. great to have in a pinch.

Lockpicking cannot open Blast Doors.

**Mastermind:** Who could be so deviously clever as you? Mastermind is your character's ability to navigate, interact with, and find pressure points in the criminal underground wherever they are. It allows your character to purchase **Plan** items at a much lower cost.

**Psychopath:** Your character's mastery of the ancient art of running at somebody while dressed in a chicken mask and swinging a lead pipe around. Practiced only by the drug-addicted, desperate, and demented. You **deal and receive 1x additional damage from all sources for every rank** you have in psychopath, up to a maximum of 10X each.

**This means that most enemies can and will kill you with a single attack. Psychopath is not a recommended skill for players.**

**Surgery:** Best described as a more complicated form of field medicine, Surgery is your character's ability to use complex procedures and tools to treat aggravated injuries. Surgery is similar to Field Medic in that it is used to heal people, but is distinct in several other ways: chiefly in that surgery *cannot* be performed without specific implements. Surgery is rolled whenever you use an item with the **Surgical** trait, and cannot be used heal allies *without* using a surgical item.

**Weaponsmithing:** Your character's ability to hone, modify, and work with weapons of all variety. Whether it's as something as simple as a sword or as complex as a death ray, a trained weaponsmith can maintain them well and optimize them to boot. Weaponsmithing is very rarely rolled for anything, but it affects the price of **modification** and **ammunition** items in the black market.

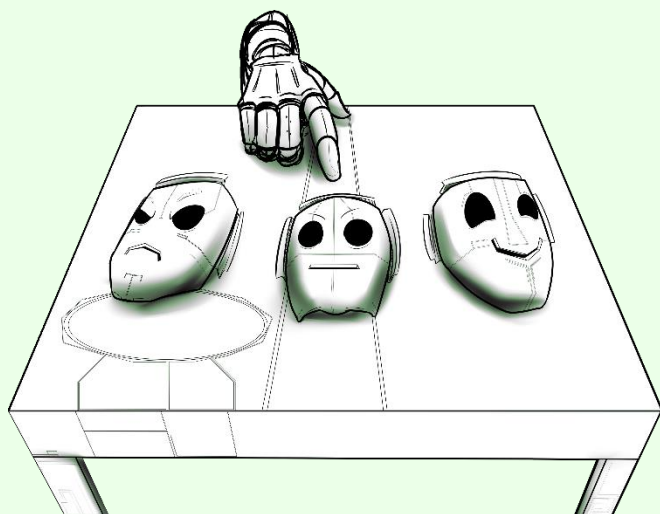

## Character Creation III: What are you?

**Meatman:** You don't have a homepage. You were born, from a womb. You bleed if you are cut. You're one of the locals. Meatmen are the first apex species on Earth, who created the inkmen; and after 1-day, they inherited some of peculiar inky qualities. Meatmen do not need ink and paper to survive the way that toons do; they were born here and bred here, and there is more of a Meatman here than there is of any toon.

Meatmen gain 4 extra skill points at character creation, for an even 40. Aside from that, they have no special powers. This is good for tryhards and people who have somewhere else to be.

**Classic:** Ah, the 20's. What a time it was to be a toon! Everything was black and white and everyone had a song in their heart. You remember what it was like, and you carry a little bit of that with you. People can't stop watching you, and you can't stop moving. Ever since you were drawn you've just had the unstoppable need to swing and dance and run around the place! But, that doesn't bother you: everything on your homepage dances too!

As a classic, you have a powerful **physical charisma**. People who look at you are liable to become distracted or enchanted by your strange shape and vibrant energy—other things just fall by the wayside when you're onscreen! Once per turn, at no action cost, you may designate a single ally within 2 spaces of you. Enemies cannot attack that ally for the remainder of the turn, so long as you do not move more than 2 spaces away from said ally.

**Golden Ager:** The only thing better than the 20's was the 50's and 60's. That was when cartoons started to get risqué—they were lightin up smokes and poundin whiskey, and helping an entire planet ignore the looming threat of nuclear annihilation. You remember Walt and Chuck and Tex and Rudy; and statistically speaking, you were probably played by Mel Blanc. You know all the best gags, and you know how to hurt yourself for others' amusement. You can take anvils to the head and shotblasts to the face...Or at least you *could*, in better times. These days...you're not much more than just another face in the sea.

As a Golden Ager, instead of expending a power burst you may expend 5 health. You may do this once per encounter.

**Skill:** Your world used to be simple. You used to fight the bad guy and save the world every week—or heck, maybe you *were* the bad guy, and you always had some crazy new plan. Maybe you just sat around and had tea parties. You didn't think about why your life worked the way it did. You didn't wonder why you never had to worry about money, or working out, or why everything you owned had your name on it and was color-coded to match you. That's just the *way it was*. Then, one day, you woke up in a world a lot less pleasant than the one you just left; and on the same day you learned that you weren't even real, you ALSO learned that you were created in a boardroom to sell toys to children. You ain't been right since.

As a skill, you have a lot of **accessories**. You may spend a single power burst to acquire a single augment from the black market and gain temporary use of it at no charge. This temporary augment is immune to the EMP trait, but will vanish once you are incapacitated **or** at the end of the encounter.

**Endtimer:** You were there when the strength of inkmen failed...that is to say, the 1990's. In this fateful decade, you saw the very best and the very worst of animation, in the final years before CGI became the norm. You saw the unparalleled heights of the fairy tale feature films, and the advent of brooding story-driven cartoons. But then again, you also saw numerous poorly-produced poorly-animated cash-ins which had about 10 frames per second. Which of these you were is irrelevant: you're here now...

As an endtimer, you carry with you the memories of both the best and the worst of the ink's last days. At character creation, choose any two **weapon or equipment inventory slots**—long, short, or compact as you see fit. You gain **another of one, and lose the other entirely**. You may change this between jobs, for 4500 hands.

**Anime:** Your heritage is venerable and proud. Since the genesis of your kind, in the 1950s, your people have always been on the edge of animation. Wrought with drama and ambition since the very earliest days of the stuff, anime pioneered CGI integration, long-reaching storylines, and octopus rape. Yours was a world of motion lines and dramatic close-ups and violent interjections—of giant robots and little girls, of multi-faceted heroes and villains! That hot-blooded flair for the wild and dramatic burns inside you now, and will ignite the whole of the Doubleearth if you free it!

As an anime, you benefit from a flair for the dramatic so strong it borders on dangerous. You can store twice as many power bursts as normal, and gain two power bursts per job instead of just one.

**Comic Man:** Ah, comic books. That great American art form which united the world—sometimes to gather around and read them in awe, sometimes to pile them in the streets and set them ablaze. These stories were dramatic and operatic, with grand characters and big ideas. For better or for worse, most comic men are from the 1980s or earlier... mostly because the 90s ruined it for everyone.

As a comic man, you possess a talent for fantastic heroism and sharp detailing. Each turn you may cast a single doodle at no **action cost**; but all doodles that you use have a **doubled IP cost**.

**Smut:** It's timeless, it's always innovating and reinventing itself, it's the driving force of several economic superpowers and the sole reason some people get out of bed in the morning. It's **PORN!** Of course, your importance to the Meatmen does not compare to the life you left behind. Your homepage was a temple of depravity and senseless eroticism, where the biggest concern anyone ever had was A/S/L. Oh, how you miss it now...

As Smut, your lifestyle requires a malleability of body and spirit, but inevitably inures you to disease, and welts, and certain sharp burning sensations. You are **immune** to Burn, Bleed, and Poison; but suffer **double effects** from fear effects, or effects which involuntarily move you.

**Scrapper:** You never made it as a star. You never made it anywhere, actually. Maybe you were on a storyboard that didn't make it into the final cut; maybe you were drawn by a child in ages past; maybe the image of your author is hazy, and not even *you* know who drew you. There are many like you, all in the same boat. Nobody but you knows your story, and you must clutch your homepage tight. You were unpublished—you have no past, and no future. **Nothing** is all you have...and that means you have nothing to hold onto, and **nothing to lose**.

As a scrapper, you cannot rely on the same tricks and well-honed masteries as other toons, but you can change yourself in ways they never could. You may not **at any point** gain or use power bursts; but **all of your body parts** have two subdermal augmentation slots instead of just one.

## Character Creation IV: Character Inventory

The last component of a TP character is your Character **Inventory**. It is different from the other aspects of your character in that your inventory is not chosen at the start of the game, but rather acquired and built upon as your character carries out jobs, gains money and power, and ascends the ranks of the criminal underworld. Your inventory is every bit as important as your attributes, if not more: expanding your arsenal of gadgets and weapons is the only way to get stronger, and without it you will rapidly get in over your head.

**Cash**—A measure of the money you currently have available. Each character begins with **2500 hands** (or credits, dollars, neodrachmas...whatever the currency is where you come from). Or maybe they start with more, if the GM wants to give you a whole bunch of high-end goodies right off the bat.

**Reputation**—A measure of your reputation, be it as a ruthless psychopath, or a thug with a heart of gold. Your reputation is subject to change based on how you conduct yourself during missions. Reputation affects you in a variety of ways; and it can just as easily harm you as help. For more information on reputation, see '**Reputation I: Infamy**' on **page 17**.

**Equipment**—A list of all the weaponry and equipment your character is currently carrying, and all the augmentations they have implanted. By default, there is room in your character's inventory for three weapons: one weapon with the **long** size, one **short** sized weapon, and one **compact** sized weapon. Additionally, you have space for two items with the **Equipment** type. Finally, on the matter of clothing, you have space one item worn on the chest (marked "**Torso**"), one piece of headgear (marked "**Head**"), one item of footwear (marked "**Boots**"), and a single tote bag in which you will carry your loot and equipment (marked "**Storage**").

You can learn all about equipment and weapons in this book. The abilities, traits, and mechanics which an item can have are listed and explained in '**Combat VII: Weapon Traits**' on **page 27**. A complete list of available equipment can be found later on in this manual—the big section marked "**THE BLACK MARKET**." It's that monolithic monstrosity that composes the last 50 pages of this book. You'll know it when you see it.

**Power Bursts**—Also referred to as "nonsense", "malarkey", "bullshit", and "fate points". This is the amount of times your character is capable of exerting their will and strength upon the world around them, to perform incredible deeds. Each Toonpunk player character can store three Power Bursts by default, but begins the game with one. Most enemies don't have these. For more information, see '**power bursts**' on **page 12**.

### Inventory Addendum:

#### Well I Guess it Could Be . . .

Sometimes, as a player or a GM, you will feel like a particular character needs a little flair—a certain touch of personalization or idiosyncrasy which can be expressed via an unconventional sort of item. This is when you may choose to call upon the "**I guess it could be**" rule—which may also be called "**counts as**" or "**proxying**" or "**fluffing**," depending on the jargon of your fellow players. This is the act of using the stats and traits of something in this manual, but applying them to something else entirely. This can be done to give an outlandish, bizarre, or eccentric item a reasonably grounded and understandable set of abilities and traits.

Say for example you want a character to use a large fish as their weapon of choice. Since there is no "large fish" item in the manual, you would instead find something that could perform a mechanical function similar to a large fish: which in this case is dealing damage at close range. You would find an item that does that—maybe the longsword, combat knife, spear, or length of bike chain—and use that item profile; but narratively, whenever describing the item or its effect on people, it would be a large fish.

Instead of describing a sword, the players responsible would describe a large smelly trout; and when it is used, instead of describing a violent meeting of steel and flesh which ushers forth scarlet plumes of vitae, you would describe the loud and wet slap of a damp salty fish slapping against the supple rosy butt cheeks of the fish's unfortunate victim. This can, of course, be used to say any item "counts as" any other thing, but generally **should not** be used to say that items count as other items available on the black market—that would soon grow intolerably confusing.

## Character Creation V: Augmentation

**Augmentation** is kind of a big deal. Exactly how big a deal is a matter of some debate, depending on what kind of game you're playing. Sometimes it's the backbone of modern society; other times it's a cheap trick you can buy at the grocery store. In the Toonpunk Doubleearth setting, it's an established science and a part of everyday life. Whatever the context, it's something in which you need to involve yourself. Augmentation is the practice of integrating mechanical parts with a biological being, to create a **fusion of man and machine** that is greater than either would be alone. It is used by police, soldiers, civilians, and—of course—crooks.

During the course of your career, you can purchase augmentations and have them integrated into your body. This can provide a number of powerful effects, from allowing you to hack computers at the speed of thought to punching clean through walls. Of course, it's possible to have too much of a good thing; and all it takes is one EMP grenade to send you to fuckville.

Augmentations can be purchased like weapons or other items; however, their effects are far more powerful, and far more permanent. Once you have purchased an augmentation, you can't just casually take it out of you again—augments can only be replaced, and surgery is expensive. As such, you must be careful when making this decision.

Augmentations have two characteristics aside from their various unique effects: **visibility**, and **location**.

There are two categories of visibility: **Subdermal** augmentations are things like nanobots or stealthily-concealed wires, which are invisible to the naked eye. While this allows you to look normal, their effects are often less pronounced than other augments. On the other end of the spectrum, there are **External** augmentations—cybernetic limbs which are plainly visible. They grant significantly more powerful abilities than subdermal augmentations, and stick out quite a bit—sometimes for better and sometimes for worse.

**Location** is the area of your body in which the augmentation is implanted, and thus which parts of you it affects. Augmentations can be implanted in your **Arms, Legs, Waist, Chest, Back, Neck,** and **Skull**. Additionally, there are **Global** augments, which are injected into the blood or muscles, and **Special**

augments, which are placed in an uncommon area. Unless otherwise noted, you may have **one subdermal and one external** augment on each body part.

If you have Augments in your inventory which use the same body part, they can be exchanged for one another during downtime. Augments which have been installed cannot be removed without being replaced, unless they have the ability to regrow biological limbs where you come from. I dunno your story, maybe they do.

Augmentation is a powerful force; but be warned, there is a dangerous downside. Having two augmentations installed on a single body part makes you vulnerable to **EMP** damage—a devastating damage type which can bypass armor and shields to damage your health directly. For information on EMP damage, see **EMP** on **page 27**.

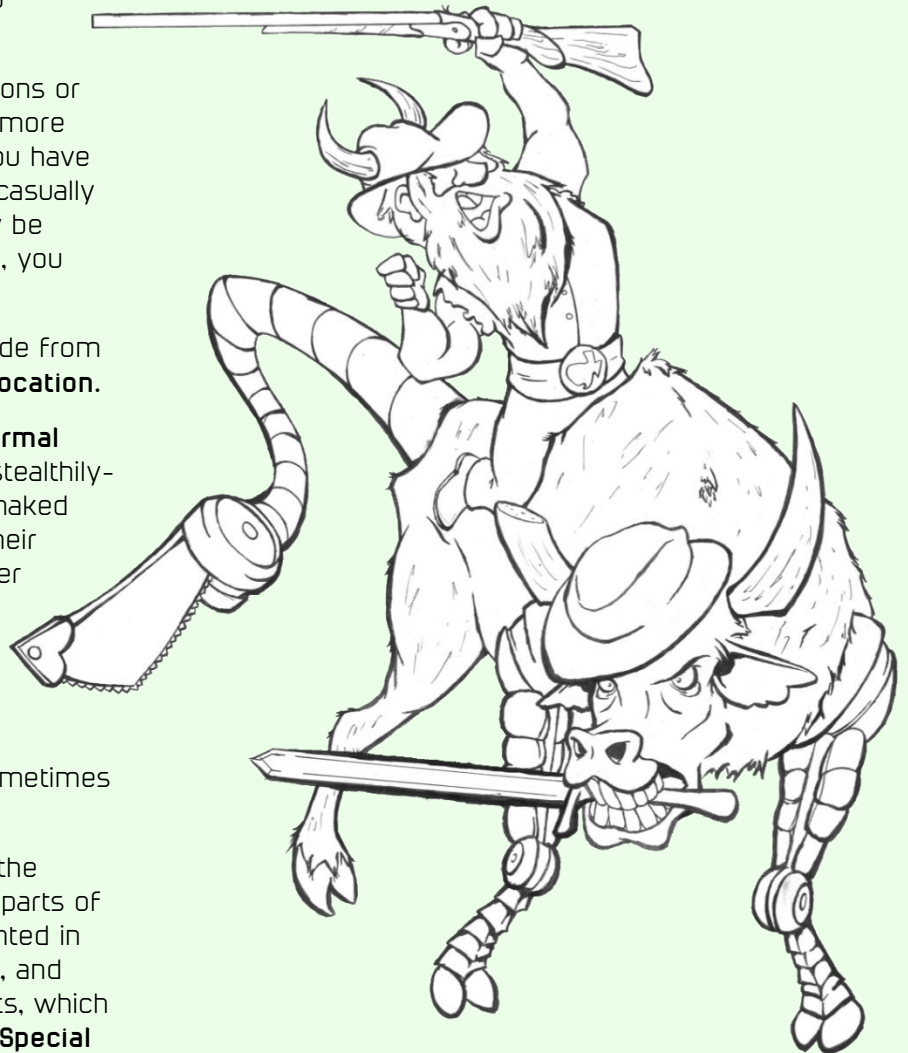

## Running the Game: How to be a GM Who Is Real Good

It is not difficult to run a game of Toonpunk.

*Preparing* a game of Toonpunk may be difficult, and *scheduling* a game of Toonpunk may be difficult, and spending a long time in the company of your friends having *fun* together may be difficult; but the actual running of the game is, itself, not difficult. Within this portion of the manual you will find a collection of helpful instructions for creating and managing Toonpunk games of varying lengths, complexity, and difficulty. If you read these carefully, you will find the experience of running a Toonpunk game to be easy and enjoyable!

### Preparing a Game I: Things Which You Ought to Note and Track

As a game master in Toonpunk, you will inherit the thankless tasks of meticulously keeping records of all varieties: your players' finances, equipment, and notoriety; the names, armaments, formations, tactics, and abilities of enemies; and the names, tendencies, motivations, desires, and the what-have-you of NPCs of all variety. What you should be taking away from this is that due to the sheer amount of information you will need to keep track of, it is a very, *very* good idea for a GM to keep a notebook—perhaps several, even. Within this notebook, you will need to keep:

- **A precise record** of your players' gear, reputation, and finances; and the net value thereof. This should be as accurate as possible and updated the very second something changes hands. This will enable you and your players to precisely ascertain their equipment and finance at a moment's notice; and make sure nobody cheats. That is not to say that we are accusing your players of dishonesty, but this *is* a game about criminals.
- **Notes on the setting and story** of your game. Things like the precise date and time of important events, the motivations and personality of important characters, and any important plot points which have yet to be established to your players. These notes will need to be kept well away from prying eyes, like those of your players or their friends. It might seem like a bad idea to keep a ledger of

such information lying around; but it is a worse idea by far to forget important information and wind up presenting your players with an adventure that makes no sense.

- The skills, behavior, tactics, and gear of any enemies your players may run into. You'll need to track everything which can pose a threat, ranging from lowly security guards to heavily-augmented gun-toting paramilitary SWAT officers. For more information on this, see '**Preparing a Game III: Population**' on **page 45**.
- The patrol patterns of any guards or other individuals who may have such things.

### Preparing a Game II: Maps

The first thing you must do in order to run a Toonpunk game is to devise an encounter which your players will face; and the first thing you must do to plan an encounter is to select an ideal map. There are a number of high-quality Toonpunk maps ideal for numerous different situations available; but with something as simple as a sheet of graph paper and a box of pencils, you can make one of your own, to suit any occasion imaginable! To create a Toonpunk map, you will need the following:

- **A sheet of graph paper**, or perhaps several. If you are creating a map with multiple different stories or areas, it will be good practice to get a different piece of paper for each area involved in the job. Make sure the paper is in good condition, because this is where the map will be drawn and it must be legible.
- **Pencils of varying color**. You will need one black, one purple, one orange, one blue, and one red; though you may of course substitute any and each of these if you are so inclined. You may also use crayons, markers, or paint if you wish.
- **A healthy understanding of level design**. A good Toonpunk map is characterized by intricacy: it is of paramount importance that any job you design be one which is capable of engaging your players' attention and giving them something to think about. There should be multiple ways to achieve any given objective, and perhaps even some which are better than others: you should take special care to, in any given encounter, create multiple avenues through which hackers, thieves, con men, or even gunmen can attain their goals. Even a simple combat encounter should have multiple vantage points, firing lines, and points of cover.



A good rule of thumb to follow is that there should be **at least three ways** to solve a problem: three ways to approach an enemy, three ways to enter a room, so on and so forth. This rule may be waived in the event that your players encounter a special puzzle, which must be solved in one particular way; but otherwise, you should make sure that your jobs are as flexible and approachable as is reasonable.

## Preparing a Game III: Population

It is not enough for a map to simply exist: it must be populated with adversity of all kinds. Most commonly this will take the form of enemies or security measures, both of which can ruin your players' days if they aren't careful. Enemies, like players, have their own **equipment**, their own **stats**, and presumably even their own lives when they're not busy being cannon fodder. Enemies **can**, in fact, be as strong and well-equipped as players; but given that such foes are often a tremendous challenge, you as a GM should save those for rare and important occasions. Your players should not feel bad for beating up people weaker than themselves—after all, they *are* criminals.

The strength and number of enemies on any given map should depend on the players' numbers and total amassed assets. This is for the sake of fairness and convenience—not the enemies', obviously, but rather yours and your players'. If you are on the market for something that has been pre-generated and thoroughly tested, there are dozens of generic enemy profiles available for your use right now on **Toonpunkgame.com**; but if it happens that you want something with a personal touch, there are a number of simple rules which, when followed, will allow you to calibrate enemy strength and formations of your own for use in your own campaigns.

Enemies cost a certain number of "points". The number of points allocated into an encounter are an easy gauge of its difficulty: **Pushover** encounters have points **equal** to the number of players; **Easy** encounters have points equal to **twice** that; **medium** encounters have points equal to **three** times the number of players, and **hard** encounters can have point values up to or exceeding **four** times the number of players.

The strength of your enemies' armaments is based on **the Benchmark**. The benchmark is equal to the value of the **total amassed** assets of the **richest player character**. For example, if the richest character in the group has a total of **100,000 hands** in equipment and cash, then benchmark will be 100,000. It will change as they acquire more loot.

**Anything which is incapable of fighting back** (a hostage, an elderly invalid, a houseplant) need not be given any equipment or skills. Presume for purposes of calculating their health that they will die only after sustaining whatever amount of damage is most convenient for involved parties. They cost no points and default to initiative 0. They can only run away from combat, and will automatically surrender if anyone uses a Freeze! command against them.

**An enemy which is intended to be of little or no consequence** (a single zombie in a horde, a poorly-trained thug, a nervous or underfunded policeman fresh out of the academy) should have usable assets—including weapons, augmentations, Doodles, plans, and anything else which could conceivably have any sort of impact on any point of the job—of a value equal to or less than **10% of the Benchmark**. They should have **12 skill points**, dispensed as you see fit; though no skill should exceed a value of **6**. These enemies are worth very little, and will only be troublesome in great numbers or if taking the players by surprise. They cost **half a point**.

**A rank-and-file enemy**—who can perhaps beat up aforementioned pathetic goons and not much else—should have usable assets equal to or less than **25%** of the benchmark. They should have between **18 and 24 skill points**, distributed as you see fit. Enemies of this caliber are unlikely to match the players in one-on-one combat; but with careful positioning and teamwork they can potentially be a hazard of some capacity. They cost a **single point**.

**An elite enemy of considerable status**—perhaps a SWAT officer, a lieutenant in a gang, or a mercenary of some skill—should be given assets roughly equal to **80%** of the benchmark, and given between **24 and 34 skill points**, as you see the need. Enemies of this class can kick a fair bit of ass and the players should take care to avoid them—and you, as the GM, should use them sparingly, to punctuate the importance of an encounter. **They cost 2 points**.

**A legendary badass enemy who is really great at what they do**—a hacker with all the right gear and connections, a loose cannon cop who doesn't play by the rules, an old army toon with nothing left to lose—can be given assets **equal to or exceeding the benchmark**, as you see fit; and as many as **36 skill points** distributed any way you want. These enemies may even (and often do) have **power bursts, augments**, and all that other badass stuff. Characters like these are significant challenges for the players and should **only be used for boss fights or encounters that are meant to be difficult**. Your players are generally best served minimizing contact and running from them. They cost **4 points**.

**To reiterate:** the total point value of the enemies on the map should be **equal** to the number of players in the group for a **simplistic operation** that's so easy it's hardly worth the time; **twice** the number of players for an **easy** operation, which they can overcome with very simple planning and minimal skill; **three times** the number of players for a **modestly difficult** operation, which can be bungled and lead to their downfall if they are not careful; and **four times** the number of players for a complex and daring operation which they will need to be very careful to pull off. Issuing enemy forces with point values any higher than that will make the operation exceedingly difficult. It will push the players to the very limits of their capability; or simply be outright impossible. You should only create enemy forces with point values higher than 4 times the player if you are attempting to put the **fear of God** into them, or if you just **hate them**.

## Preparing a Game IV: The Police

If you are running a game of Toonpunk, and your players are anyone other than the actual Banco Central robbers, the cops are eventually going to get called. This is **bad** for your players: the police greatly outnumber them and have much more equipment and manpower than they do—and they **don't stop coming**. Once the police are called, the job is effectively on a timer: while the players may resist the police for a time, they eventually *will* be overwhelmed by strength of arms and numbers, as more and more responders are dispatched to the scene. However, there is a fair bit of time between the players being detected and the law bringing its maximum force to bear. When emergency responders are called to the scene of a crime, they come in waves of increasing intensity.

- The police are called to the scene if the players trigger a security alarm, or if someone who is aware of the crime in progress calls them for help. After the police have been called, the police will arrive and begin attempting to arrest the players after a few short turns. When the police are called, roll **1d10**. The police will arrive after that many rounds. For every 20 points of infamy the players have, it takes an additional round for the police to arrive—they're not in a tearing hurry to meet the reaper, after all.
- In most urban settings, it can be presumed that most civilians will have cell phones, and so will call the police as soon as they pass out of the players' eyesight. For a slightly less frustrating experience, you may instead decide that civilians only call the police after they pass beyond the edge of the map.
- The number of turns until the police arrive is reduced by 1 each time someone calls them, and it can be further reduced by certain high-level enemy abilities. Your players will want to neutralize both of these!
- Remember that while the police may be the largest threat to the players, they cannot reach everywhere. Don't have the police arrive before the players do something to tip them off—they **should** be able to circumvent a response wave through careful planning and fast movement. Additionally, if you as the GM feel like it wouldn't make sense for the police to respond, or don't want to have to go through the hassle of setting up a response wave (because let's face it, sometimes you just feel lazy), it is entirely acceptable to just say the police are all out having donuts or something like that.
- The police are (theoretically) more interested in arresting the suspects and repairing the damage done than in killing them. Make sure the police have **nonlethal** weapons and make **liberal use** of freeze actions. Not **everything** is about killing.
- But some things totally **are**. If the players return lethal force against law enforcement, the police may begin shooting to kill. Use your own discretion to decide when to raise the stakes.

## Preparing a Game V: How to Prepare a Campaign

There's more to a game of Toonpunk than robbery, even though that's very much the meat and potatoes of the matter. The glue that holds these moments of adventure and daring together are the characters themselves: the cartoony and outlandish rogues who drive the heists and the events around them. It is these characters and their struggles that give your players the desire to succeed, and the fear of failure. You should take particular care to be very familiar with them, because **that** is the way to a truly engrossing and memorable campaign.

You will find, below, a list of bullet point tips and strategies for preparing games and campaigns that your players will enjoy and look forward to. While none of these are hard and fast **rules**, per se, it may serve you well to take these into consideration!

- You and your players are on the same side. Even though you are the antagonist, you should **never ever ever under any imaginable circumstances** forget that you are trying to make the **characters** miserable, but keep your players entertained. If they are happy, they will make you happy.
- Always make sure **the games you run are fair**. "Fair" in this case is defined as something that you can reasonably expect them to overcome with effort and intelligence. As long as your enemy placement is balanced, and you do not require the players to act upon knowledge they cannot be reasonably expected to possess, you should do very well with this. Break this rule only if you are **very certain** that you have reason to: you **usually** will not.
- Make sure your campaign is **understandable**. This is about as simple as it sounds: your players should be able to understand the plot of your campaign, as it pertains to them, with minimal effort. It is good form to provide a short quickly-readable list of important background details, and it is important to keep these succinct and legible. If there is any required reading or listening for your players, make sure to provide it ahead of time.

## Preparing a Game VI: Tips for Assembling a Story

Writing a campaign is not the easiest thing in the world. It is not *difficult* per se, but it is still the most difficult part of playing this game. It requires the assembly of an intriguing story which gives your players a reason to care about the outcome of their adventures, while also contriving numerous reasons to have them rob a wide variety of banks, museums, and other repositories of wealth. Included below is a small list of tips for creating an exciting and memorable campaign that makes sense, but not too much sense.

**Regularly consume fiction** which is in the same approximate genre as your campaign. As the GM of a Toonpunk campaign you should have a familiarity with the vagaries and nuance of science and criminal fiction—which can range in familiarity from time-tested classics like *Goodfellas* or *Blade Runner*, to the obscure weird tales of amateur fiction periodicals. They will readily serve as a vehicle by which you might acquaint yourself with the techniques of writers who went before you. These can range from specific character archetypes and caper ideas, to broader notions about criminal society and hierarchy. Make sure to do this regularly and with a wide variety of material, to keep your inspirations varied and exciting!

Basically what we're saying is **steal** as many ideas as possible from everything you can, and eventually people will mistake your story for an original plotline.

**Make sure your players' characters are important to the story.** It's all well and good to have an intricate multi-layered crime epic planned out; but the important thing to remember is that while Toonpunk is *like* a book, it is *not* a book. Your players, as a rule, are not interested in watching a bunch of NPCs hash out drama between themselves. You must make sure that your players drive the events of the campaign, or are at the very least key to their proceeding. If your players don't feel like their contribution to the story matters, they will cease to pay attention and will almost inevitably find another way to occupy themselves.

The **very first thing** you need to do when you begin working on a campaign is to compose, for your own use, a summary or outline of your campaign's plot. This will be tricky, because unlike writing a book or movie there is no way to control what the players will and won't do; and keeping your players' actions relevant is the easiest way to keep them invested and happy. No matter what you do, **you will need to be ready to improvise**: you will need to create dialogue, story, and encounters on the fly, with just a few minutes of prep time.

Sometimes you may wish to create a story-light adventure, where there are not many NPCs or story beats prepared ahead of time. This emphasizes the players' moment-to-moment actions (namely, the crimes they commit) above all else. This is ideal for many situations: casual games between friends; pick-up games where player attendance is irregular; or lighthearted adventures where no particular attention will be paid to the long-term ramifications of your players' capers.

However, sometimes you will want to exercise your narrative pretensions more distinctly—to create an epic crime caper that spans multiple continents and conspiracies, where the players' actions will have lasting consequences on an ensemble cast of NPCs, and locations. You may plan out encounters or lines of dialogue months in advance, and carefully forecast shocking plot twists or events!

In this case, you will need to exercise a much defter hand, in order to make sure your players' decisions can exist in concert with your grand designs. The best thing you can do is try to predict their actions in advance, and thus craft the story built around these suppositions. This can be done most easily by stalking them relentlessly for months at a time so that you learn their personalities and eventually come to know them better than they even know themselves.

However, in the event that you cannot do this, you are best served by creating a bullet point list of important robberies or plot points you would like your players to hit upon, while leaving the fine details of how they get there up to them.

Say for example you want to run a campaign consisting of several jewel robberies, which are interwoven with investigations into a ministry conspiracy. In this case you would assemble a bullet point list consisting of:

(1.) Players fight Corrupt Cops at Bar and learn that they are extorting money from a jewelry store for protection.

(2.) Now that the police have all been beaten up, Players decide to rob jewelry store while the police are turning a blind eye to it.

(3.) Players learn that there's a rare diamond on exhibition in town and decide to steal it, while corrupt cops pursue.

There are many ways to compose an outline, none of which are inherently better than others. You may choose to start at the very beginning and work through your plot in a linear and straightforward fashion; or you may begin with a single particular idea or heist in mind and work out the finer points as they come to you. Your plot can consist of anything and can be written in any order; but whatever else you do, just remember these golden rules: keep your players **central to the story**, keep your story **simple and explicable**, and **never** be so married to your work that you cannot throw it all in the trash and rewrite the whole thing from dust at a moment's notice.

If you have done all of the above and your players insist on ignoring, mocking, or disregarding your efforts as a GM, you must rip the flesh from their bones and stake their heads in your living room as a warning to the others.

## Preparing a Game VII: House Rules and Touching Base

Let's level with each other here: there are a lot of rules in this game, and not all of them are going to be to your liking. As a GM you won't want to track certain things, and you'll want to omit certain other things for the players' convenience. Maybe you have some ideas that you think would make the game more interesting or fun, and want to try them out. These nonstandard rules modifications are called **House Rules**, or **Table Rules**. These can include fundamental modifications to the core ruleset such as "You may not buy the Radcannon because I think it's too powerful"; or supplementary modifications like "You get +2 to acting rolls whenever you talk with a funny accent."

House rules are entirely up to the GM's discretion. There is nothing inherently wrong with these rules, but it is important to alert your players to their presence beforehand.

It's always a good idea to **touch base** with your players before a game starts, to make sure that you have a full understanding of house rules, of the tonal nature of the campaign, of any preferences or quirks of the other players, and of the overall objective of a given job. This makes sure that you and your players are on the same proverbial page, and that you won't spend time misinterpreting each other's intentions.

Say for example, you personally don't feel like the upcoming game will rely on or benefit from long in-depth conversations between characters and NPCs. Before the game begins, it would be a good idea tell your players that they shouldn't focus too much on conversation, and that you won't be making many acting rolls.

Contrarily, you might be running a complex caper where the characters con elderly pensioners out of their life savings in a real estate scam. Because of the heavily dialogue-oriented nature of the game, you would tell your players ahead of time that you will often ask them to make acting rolls, and that they should pick their words carefully.

## Preparing a Game VIII: How to Set Up a Game

The last thing you need to do is **prepare the physical game for play**. As the GM, the burden of preparing the game falls squarely on you. While you can ask your players for help arranging the pieces, it is your responsibility to provide the map and the things that go on it. To prepare a game of Toonpunk, you will need to acquire the things mentioned aaaaaaall the way back on page 2: a table, some pencils, a map, character sheets, and some tokens. The ideal way to prepare these is to arrange the map in the center of the table, and the tokens in their appropriate positions. The players begin the game in an escape zone, while the NPCs begin wherever you feel like they should be—which is usually doing their jobs and minding their own business. You should keep any NPC character sheets readily accessible at times, while your players may keep track of their own sheets. Set the pencils aside somewhere you can reach them.

With this setup done, you are ready to begin!

## Preparing a Game IX: Interacting With Your Players

As the GM, you carry the lion's share of responsibility. The players have only to overcome the trials you lay before them and their contribution will have been made; but *you* must animate a whole world, assemble an engaging story, design multiple stealth and combat scenarios, and above all else make sure that all the ingrates at the table have fun. It's thankless, but it must be done. After all—without you, there is no game!

While the previous section was about the must-haves and must-dos of preparing the game for play, this part of the manual is a collection of suggestions, guidelines, and informal regulations for dealing with the ever-troublesome human element of the game. That's things like improvising dialogue, drumming up story and plot points on a moment's notice, or even just getting them to shut up and listen for a little bit.

### I Don't Trust Him!

This is a game about criminals, and criminals tend to be bad people. In a game of toonpunk it will inevitably happen that two player characters disagree. This is not a problem. The problem is when two **players**, aside from their characters—distrust one another. This is troublesome, and can keep the game from progressing smoothly. You, as the GM, are the designated mediator of the group: do what you can to work through these issues; and if you must, consider asking the players to take a temporary break from your game if they cannot find it in themselves to get along.

Alternatively, you can let your players backstab each other willy-nilly if you don't mind the group going to shreds—say, for example, you're only running a single heist instead of a campaign. However, if you expect such things to occur, notify every single player at the table ahead of time, to avoid anyone being genuinely upset by a fictional betrayal.

## Dave, Don't Do That.

Sometimes your players will do...interesting things. Say, for example, your players have been tasked with protecting the History Eraser Button from a collection of terrorists. If one of your players—referred to as “Dave” in this case—decides that instead of guarding the History Eraser Button, he'd rather push it (or otherwise wants to irrevocably disrupt the other players' enjoyment of the game) you as the GM may simply say **“Dave, don't do that.”** If Dave asks why, you may answer “Because nobody else wants that,” “because that's stupid,” or for the sake of expediency, “just because”.

## Let's Split up!

Your players may sometimes insist on splitting up their crew to cover multiple objectives at once. This is great for them, because it allows them to set up and enact complicated plans; but is unpleasant for you as the GM. Each split means you have to divide your attention another way, and each will be clamoring for attention. While you *could* ask your players to refrain from doing this, that limits their options; and so, you should instead try these tricks for minimizing the strain it will put on you.

- **Divide your attention between each group sequentially.** If the players split up, and you are reasonably certain that their actions will **not** directly intersect—say, for example, they are having two different conversations which are not particularly urgent—you may choose to play their scenes from beginning to end without splitting your attention, by doing one and then the other. In this case, tell the players who are not involved in the current scene to take a few moments off to stretch their legs, or have a drink, or light up a fatty. Call them back in when you are ready to play through their scene.
- **Take Turns.** If the players are split up in a way that requires you to divide your attention, and their actions **are** likely to affect one another—say for example, one group is mingling and navigating a high-class party, while another group is attempting to overpower a collection of saboteurs attempting to sabotage that same party—you may ask your players to roll initiative like they would during combat, and resolve their actions in turn that way. While this still requires you to manage multiple scenes simultaneously, having a numeric value assigned to each player will considerably reduce the strain upon you.

## Improvising Dialogue

Dialogue is a valuable addition to any game: while it is not strictly *necessary*, since exposition can be delivered impersonally, it builds flavor and gives characters opportunities to express themselves. Because most conversations are sharp off-the-cuff affairs without any pre-determined paths or options—at least, they are unless your players can't hear, talk, or write—you're going to need to hold a naturally-flowing discussion which imparts both flavor and information to the players.

Improvising dialogue is easy, and is just an extension of getting into character. The easiest way to figure out how a character would respond or speak is to ask yourself questions about them, like:

- What is the character's general temperament? Are they polite, businesslike, placid, etc?
- What is the character's immediate situation? Are they in danger, or frustrated?
- Does the character have a distinctive accent, verbal tic, or speaking habit?
- What does the character know of the players? Does he or she know who they are? Does the character have any particular response to the players, such as fear or admiration?

## Improvising a Story

You **cannot guide players through a campaign** so much as you can aim them in its general direction and hope for the best. Players—who, their cursed habit of not being you, have their own thoughts on whatever you give them—will devise their own responses, interpretation, and solutions to the narrative intricacies of your campaign; and the best thing you can do is just try and make sure that all the maps you drew can get put to good use. Because stories are complicated and role-playing games make them even worse, we can't really give you much advice on how to string a story together, except for this:

**Make shit up.** If you went through all the trouble of drawing an elaborate 7-story heist and the players decide they'd rather be rock and roll stars instead, bullshit every single thing you can think of to make sure the crazy train doesn't completely skip the tracks. Good luck, you poor bastard.

## Improvising Everything Else

Your players are going to do things you didn't expect to have happen. This will happen quite regularly, in fact. Maybe they'll think of a solution to a puzzle you hadn't imagined; maybe they'll find a way to run circles around an enemy you expected to be unbeatable; or maybe they will, through directed force of idiocy, fuck up something you didn't think they could fail at. When things don't go according to plan (which is always), you're going to need to **improvise**. Improvising mechanics isn't hard, but it's something you'll need to practice a little bit before you can regularly do it well.

While the rules of combat mean that there's very little room for confusion, things like locked doors, traps, or conversations are a little less set in stone; and the players will find interesting ways to deal with them. As the GM, your powers of arbitration mean you can call it any way you see it, but there are some good guidelines to keep in mind.

The big one is this: is what the players come up with **smart, exciting, or in any way deserving of a reward**? Then reward their cleverness with success and praise. If their solution to a problem is stupid, simplistic, or boring, consider asking them to come up with another.

Say for example your players arrive at a nanotech-locked door which will only open upon hearing a specific phrase. You, for your part, might intend for them to learn the password by placing a hidden

microphone near the room and listening. There are many other ways the players might approach this situation, not all of which are equally worthy of validation. For example, they might coerce or bribe an NPC for information; if a camera is present, they might try to access its tapes; or they might call the site administrator and finagle some way to have it remotely opened. Each of these are clever and reasonable ways to work around the door, and are good reasons to grant the players success even though you did not have it in mind.

However, they could've tried something as foolish as shouting random phrases at the door, or headbutting it repeatedly. You are not **required** to reward anything you find meritless, and should tell your players if their methods will not succeed.

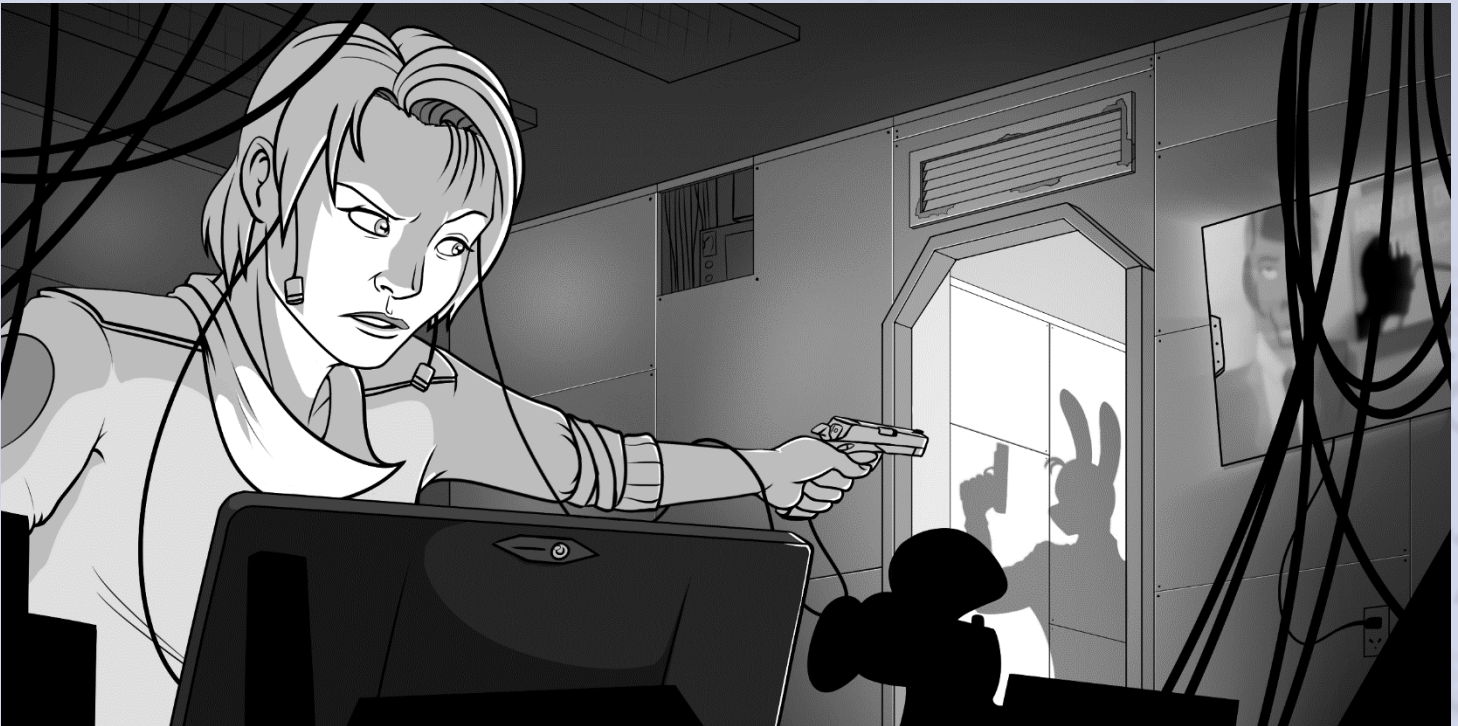

# The Founders of the Feast

Toonpunk was funded by the generous donation of 42 people. Without these golden-hearted thieves, this book would never have seen production. I now flagellate myself daily and offer my blood as thanks for their patronage. Take a moment as you read this page to appreciate their example and raise a glass to their well-being. May fortune favor them, and may their pens never run dry.

## The Great Black Queen

My Grandma

Red Sage

Nick Savino

ShadeHollow

Alexander Hall

Baffle Blend

Bruce E Coulson

Hop Stop and Roll

Mark Edwards

Michael and Brian Goubeaux

Luthorne

Steven Reams

Zinthoraz

Joshua S

Andrew Miller

Bryan Considine

Daniel "UrbanCritic" Feldman

David Starner:

Edgardo Cruz

Jarrett Kazuhiro Masunaga

## Jeremy "Rogue Leader" Scroggs

Kevin Garza

Konstantinos Dimopoulos

Raevyn Fletcher

Rebecka Gaither

Reuben

Sabrina Klevenow

Timothy Martin

Tom Bither

Trip Space-Parasite

Zach "The Beastmaster" Loman

Austin Sylar Soren

David Markham-Jones

David, just David

Firebat4321

Ian McFarlin

Mark Terrano

Philip Sacramento

Ray Goldberg

Several Anonymous Persons



## The Black Market

As a Professional Paramilitary Operator (which is the very definition of “illegal”) you will not be able to acquire everything you need to do your job through legitimate channels. For this reason, all punks make use of the black market, through a multitude of channels. On the black market, people are charged “reasonable” fees for weapons, vehicles, and housing—all of which have been scrubbed clean of identification. The items you can buy from the black market are listed below, and sorted for your convenience. If you ever find that an item you have purchased or stolen is no longer of use to you, you may seek to refund it to the black market at the GM’s discretion, for the price that they determine.

## Entry Level Equipment: For Those Who Are Not Long For This Earth

### Unarmed (Free)

**CAP: INF | DAM: 2 | RNG: 1 | Melee**

Fisticuffs! Pugilism! A little bit of the old left hook! Unarmed combat is an essential skill for any operator. Fortunately, it’s always free. At least, until God starts charging for limbs.

All players always have Unarmed equipped, and it does not take up an inventory space. Unarmed cannot be bought, sold, or unequipped owing to the fact that it is representative of your character’s limbs and nobody wants to buy an old severed arm. Unarmed cannot deal damage to armored target with an armor value higher than 3. However, clashes made with unarmed cannot be ignored, and **MUST** be resolved via evasion or a counter-attack.

**Silent, Undetectable, Nonlethal, Assassin 0**

### Shiv (Free)

**CAP: INF | DAM: 1 | RNG: 1 | Compact | Melee**

The classic weapon of prisoners and gangsters everywhere, made of a sharpened toothbrush or something similarly cheap and flimsy. While shivs are a common sight among the prisons and the gangs of the lower city, no self-respecting operator would be caught dead using a weapon this worthless. But, beggars can’t be choosers...

The shiv cannot be used in a clash. At all.

### Rock (Free)

**CAP: 1 | DAM: 1 | RNG: 4 | Compact | Throwing**

It’s a rock. You throw it at people. You only get one, and you have to go pick it up again after you throw it. Really not a good idea.

### Prayer (Free)

**SHD: 0 | ARM: 0 | Nonexistent**

You pray that you don’t get shot. This virtually never works, and as such it is highly inadvisable; but when money’s tight, you get what you get...

## Basic Equipment: Low Rent Tools for the Amateur Operator

### Cleaning Supplies (\$500)

#### Equipment

A rag and a spray bottle of ammonia. While it doesn’t smell particularly pleasant, it allows you to remove bloodstains quite efficiently—and that can make all the difference in the world on a stealth operation.

While Cleaning Supplies is in your inventory, you may expend one action to remove any bloodstain to which you are adjacent.

### LunaSea Survival and Combat Knife mk1 (\$1000)

**CAP: INF | DAM: 2 | RNG: 1 | Compact | Melee**

One of the LunaSea company’s most popular orders is the Survival and Combat Knife, which is popular among soldiers both for being incredibly durable, and for having this adorable little picture of a dolphin in a hat on the handle.

### LunaSACK (Punkspec) (\$1500)

**CAP: INF | DAM: 2 | RNG: 1 | Compact | Melee**

The simplistic nature of the LunaSACK has led to a number of unofficial variations—the most popular of which is the addition of a simple cufflink-style sheath and hilt combo, which allows the weapon to be retracted and hidden from view, as well as smuggled past metal detectors.

**Undetectable, Pierce: Mesh**

### Kapricorn Frontline Blade (\$1000)

**CAP: INF | DAM: 3 | RNG: 1 | Short | Melee**

Ever since Ink became part of the world, combat—between entire nations, or simply between gangs—relies on the uncoordinated brutality of melee combat. It is here that we find the Kapricorn arms corporation: as a manufacturer of knives and swords, they cater to trench warfare and old-fashioned psychopaths. The Kapricorn Frontline Blade is one such weapon: a modern take on the shortsword. While you can’t hide it as well as a knife, it packs a bit more of a punch.

**Pierce: Mesh**

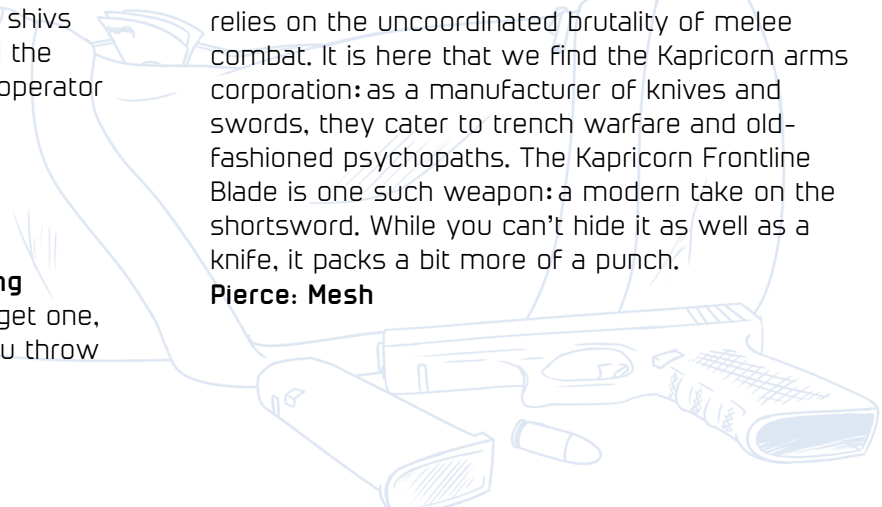

### **S&W Mayfly Repeater (\$1000)**

**CAP: 10 | DAM: 2 | RNG: 10 | Compact | Bullet**

The Snort And Whinny corporation has a long and prestigious history of manufacturing home defense weapons and frontline firearms alike; but they've had some duds here and there. The S&W Mayfly Repeater is one such dud: with a short effective range and pitiful firepower, the Mayfly is just as much of an annoyance to shoot as it is to be shot by. Despite these shortcomings, it has experienced enduring popularity because of its low cost, plastic frame, and high durability—it is what most people think of when they hear the words "disposable gun".

### **S&W Beesting Revolver (\$1000)**

**CAP: 4 | DAM: 4 | RNG: 8 | Short | Bullet**

The Snort and Whinny Beesting is arguably the iconic pistol of the modern era. Initially produced as a weapon intended for police forces and ranking officers, the Beesting rapidly gained a following in the outlands and the Radzone, as well as punks in industrialized areas. Despite its less-than-stellar range and its pitifully small clip size, the Beesting packs a tremendous punch for its price; and in an industry where the first shot is often the difference between life and death, that's enough to make popular with thugs and lawmen alike.

### **S&W Wasp-Sting Revolver (\$2000)**

**CAP: 4 | DAM: 4 | RNG: 8 | Short | Bullet**

While it never saw the fame of the original, the Beesting's offshoot design—the Wasp-Sting—is sought by professionals and collectors because of its superior stopping power. The Wasp-Sting is much like to the Beesting, but it benefits from a moderate increase in penetration capabilities.

**Pierce: Mesh**

### **Thunderbolt Munitions Hunting Rifle (\$1500)**

**CAP: 1 | DAM: 6 | RNG: 10 | Long | Bullet**

The Thunderbolt Munitions corporation was originally nothing more than a tap-and-tack store on the Trail; but during the lawlessness of the Great Expansion, Old Man Thunderbolt created his iconic hunting rifle. While it was heavy, and prone to breaking down, it made a statement that informed the company's philosophy ever since: shoot once, confirm kill, then go home.

**Pierce: Mesh**

### **Atlas Outfitting Protection Vest (\$500)**

**ARM: 5 | Mesh | Torso**

If you need to be told what body armor is, you really shouldn't become an Operator.

### **Shortbow (\$1500)**

**CAP: 1 | DAM: 2 | RNG: 8 | Long | Arrow**

The bow is one of the oldest forms of missile weapon in the entire world, and it's still in use today: case in point, the shortbow. It's a little piece of metal with a fiber string on it, which shoots arrows. Thanks to its minimal noise and respectable accuracy, it's good against unaware and unarmored targets; but, it's near useless as a frontline weapon.

**Silent**

### **Length of Bike Chain (\$1500)**

**CAP: INF | DAM: 2 | RNG: 1 | Compact | Melee**

You probably don't need to be told what this is for. Bike chain is up there with baseball bats and lead pipes as far as iconic gangster weaponry goes, and for good reason: it's inconspicuous, easy to find, relatively cheap, and above all else, painful. While it might not hit as hard as a baseball bat or cut as deep as a frontline blade, the fact remains: a properly-made bike chain, wielded well, will knock the SHIT outta something.

While you have the Bike Chain equipped, you may spend any number of actions spinning it. For every action you use spinning the bike chain, its damage increases by 1, to a maximum of +4. After making an attack, this number will reset if you spend one turn without making an attack with this weapon.

**Nonlethal, Simple**

### **APSF Brown Box (\$1000)**

**ARM: 2 | Mesh | Torso**

The end-all and be all of stealth tools since the late 80's, the Cardboard Box has been a longtime standby tool of cartoon characters, mischief makers, and legendary mercenaries for longer than anyone can remember. That's because it's simplistic, but effective: by hiding oneself inside a cardboard box and then standing in an inauspicious location, you can become virtually invisible to the eyes of the inattentive and unfamiliar. Today, leaps and bounds have been made in cardboard box technology, in ways most primitive thieves could have only imagined. By mounting small pleather straps on the inside of the box, it becomes possible to carry it with you even while walking normally; and a small tank-like hatch on the front allows you to retract and extend your neck and head as necessary. Finally, it's like 20% Mesh so it can actually stop a 22 round, and that's badass. They're...not very durable, though.

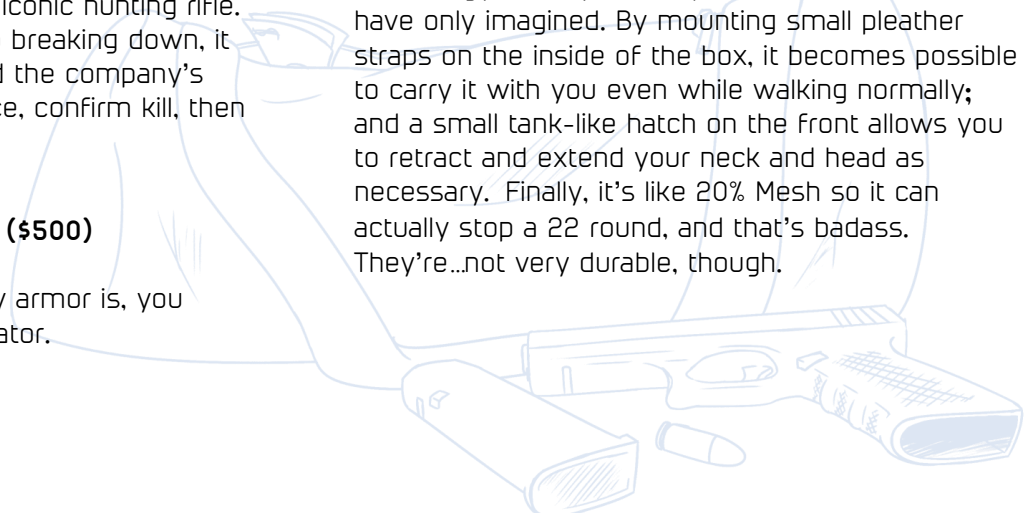

While wearing the ASPF Brown Box, you will no longer be noticed should you enter an enemy's sight sense, as long as you didn't move in the previous turn. After the APSF Brown Box has been broken, its effect ceases to apply. The APSF Brown Box may be worn in conjunction with other armors, but only so long as the other armor has an ARM value equal to or less than that of the APSF brown Box.

**Disposable**

## Good Guns: Balanced Ballistics for an Experienced Operator

### S&W Cranefly Autopistol (\$10000)

**CAP: 30 | DAM: 2 | RNG: 12 | Compact | Bullet**

While the Mayfly is a notorious piece of shit that people only buy in the absence of anything else, its sequel—named the Cranefly, for the sake of the theme—actually earned its following. This little plastic fantastic benefits from an extended mag and a 3-round burst, as well as a thicker round which can penetrate armor more effectively than the old one. While this isn't exactly an assault rifle, it's an excellent holdout weapon and is often used for intimidation, suppression, and infiltration. Give this one a look, if you have the scratch kicking around.

**Automatic 3, Undetectable, Pierce: Mesh**

### Black Stallion AR (\$25000)

**CAP: 30 | DAM: 4 | RNG: 15 | Long | Bullet**

The Black Stallion AR-3 is a cutting-edge weapon—it debuted about 15 years ago, and in since then it's become synonymous with military efficiency and precision. The BSAR-is the mainline assault rifle of the ministry. It is prized for its versatility, range, and stopping power. However, it has yet to find any lasting popularity among Operators or gangsters, because of its considerable complexity, which makes it difficult—if not impossible—for most amateur-hour gunmen to maintain it well.

**Automatic 2**

### UA Splitfoot Submachine Gun (\$10000)

**CAP: 30 | DAM: 1 | RNG: 15 | Short | Bullet**

The Uberarms Splitfoot Submachine Gun is a favorite amongst police and CorpSec, and has been since its creation in 2283. This is due to its low recoil, large magazine, and superior rate of fire—which are, tragically, offset by its weak stopping power.

**Automatic 5**

### Kessler Munitions OM2 (\$15000)

**CAP: 30 | DAM: 3 | RNG: 10 | Long | Bullet**

The Kessler Munitions *Ottomurder 2* is one of the most popular repeating rifles of all time, and for damn good reason. Along with its distinctly imposing name, the OM2 sports is durable to the point of freakishness; and it is not uncommon for one to remain in work order for over a century with only occasional light maintenance. Despite its ease and flexibility, however, the OM2 suffers from comparatively weak stopping power and range.

**Automatic 4**

### S&W Selleck–Pattern Magnum Revolver (\$20000)

**CAP: 4 | DAM: 6 | RNG: 12 | Short | Bullet**

Four chambers, two triggers, three-hundred-and-fourteen-thousandths of a good idea. The Selleck .314, also known as the Goodwill Gun by lovers of vaguely old-timey slang, was Swhinny's first attempt at mass-producing a weapon that was usable by all races without modification, and as such is just a scant seventy years old. While the weapon itself is a thing of beauty—incorporating a durable break action, as well as a long rifled barrel for increased range and accuracy—its remarkable weight and heft make it difficult to re-adjust quickly, and consequently impractical in close quarters. Thus, it was never officially adopted by any standing army; however, it remains a popular item among sportsmen and police—and is the signature weapon of at least one popular television detective.

**Pierce: Ceramic, Recoil 4**

### Thunderbolt Munitions XpRs–01 "Expressway" Antimaterial Rifle (\$50000)

**CAP: 16 | DAM: 5 | RNG: 10 | Long | Warhead**

The Explosive Rifle Series-01 Antimat Rifle was developed by Thunderbolt Munitions for use by cybernetic infantry squads within the Vietnam DMZ—primarily to hunt the very large number of radioactive mutants that dwelled there. While interest in the DMZ very rapidly died off, interest in this weapon did not: even though it weighs in at a crushing twenty-five pounds, nobody ever really forgot that it shoots miniature rocket-propelled warheads at a rate on par with many marksmen rifles. While wielding one of these is difficult, it's worth the trouble.

**Automatic 2, Blast 1, Recoil 4**

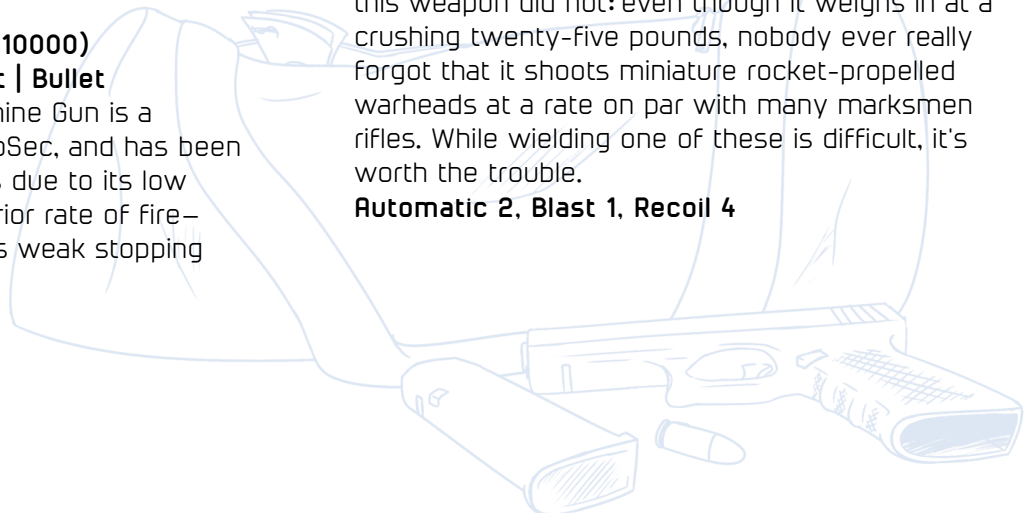

### **S&W NMH .44 Revolving Revolver (\$45000)**

**CAP: 32 | DAM: 6 | RNG: 12 | Short | Bullet**

In the original onyx age, the rise of the Longcoats proved to be a lucrative business opportunity for the Snort and Whinny company. The influx of high-stakes showoff criminals lead to an all-time high in revolver sales, and thus incited the creation of some new designs. Intended primarily for vanity and flash, the S&W New Model High-Capacity Revolving Revolver was designed to look as outstanding as possible, which would then be sold for outrageous prices to mall ninjas everywhere: some unnamed genius commissioned a bunch of Sellecks with custom engravings on the barrels—and, more importantly, modified the cylinder to hold a super-oversized ring of moon clips, which would themselves be rotated and switched out using part of the revolver's normal action. The result was a dangerously distinctive, uncomfortably burdensome, and ridiculously effective assault weapon, which was almost immediately immortalized for its sheer audacity. The NMH44 is closely tied to operator culture, and is still used today.

**Dead Giveaway, Limited-use 1**

### **TSD Windstorm Submachine Gun (\$15000)**

**CAP: 30 | DAM: 2 | RNG: 8 | Short | Bullet**

The idea that submachine guns, by design, have a higher rate of fire than other firearms is pure and unapologetic fabrication. Submachine guns are nothing more complicated or distinctive than an automatic weapon that is meant to chamber pistol rounds. *Twin Suns* submachine guns, however, are designed to be nothing more than glorified bullet holes—and this is a task they accomplish with unerring effectiveness. By using a pair of reciprocal barrels and a patented twin-railed magazine, The Windstorm is capable of producing a truly impressive amount of fire over a very short period of time—making it an excellent choice for dispensing of lightly-armored targets, or for softening up heavier ones.

**Automatic 5**

## **Getting Sassy: Silent Arms for Secret Agents**

### **LunaSea Operator's Pistol (\$10000)**

**CAP: 10 | DAM: 4 | RNG: 8 | Short | Bullet**

While the LunaSea Operator's pistol was meant for *military* operators, it has become quite popular among the criminals of the same title. This is due to its low recoil, relatively large magazine, and—most of all—its integrated suppressor and plastic frame, which combine to make it a valuable tool for Special Forces, thieves, and assassins.

**Undetectable, Suppressed**

### **APSF PB-1 Pneumatic Bolter (\$15000)**

**CAP: 4 | DAM: 4 | RNG: 15 | Long | Arrow**

Today, archery is the domain of two kinds of people: sportsmen, or mud-spattered twentysomethings who are stranded on jungle islands. This is a shame, because as operators and action movie buffs will tell you alike, there's nothing as horrifying as turning a corner and finding a dead guy skewered to a wall. To blend the fear factor of archery with the ease of conventional firearms, the Apogee Satana Foundation—who are known for their many breaches of Wasteland accord—assembled the PB-1. With a simple system of compressed air pumps, the PB-1 is capable of firing filed-down rebars at sub-ballistic velocities. While this doesn't have the stopping power of a gun, it is virtually silent and pierces Mesh.

**Pierce: Mesh, Silent**

### **Butter Bomb (\$5000)**

**CAP: 1 | DAM: 0 | RNG: 10 | Compact | Thrown**

This spherical pressure-release grenade is loaded with a powerful peanut-based psychological weapon that is known for its ability to render equines, canines, and other mammals stunned, confused, and mute. Any enemy hit with this weapon will be unable to sound the alarm or cry for help until they spend a turn detangling themselves.

**Blast 2, Limited Use: 1, Idiot-Proof, Disposable, Stackable**

### **Blackjack (\$7500)**

**CAP: INF | DAM: 2 | RNG: 1 | Short | Melee**

You might ask yourself, "Why am I paying seven grand for a pipe wrapped in some rubber"? Shut up.

Use of the blackjack does not create bloodstains.

**Silent, Undetectable, Assassin 4, Nonlethal**

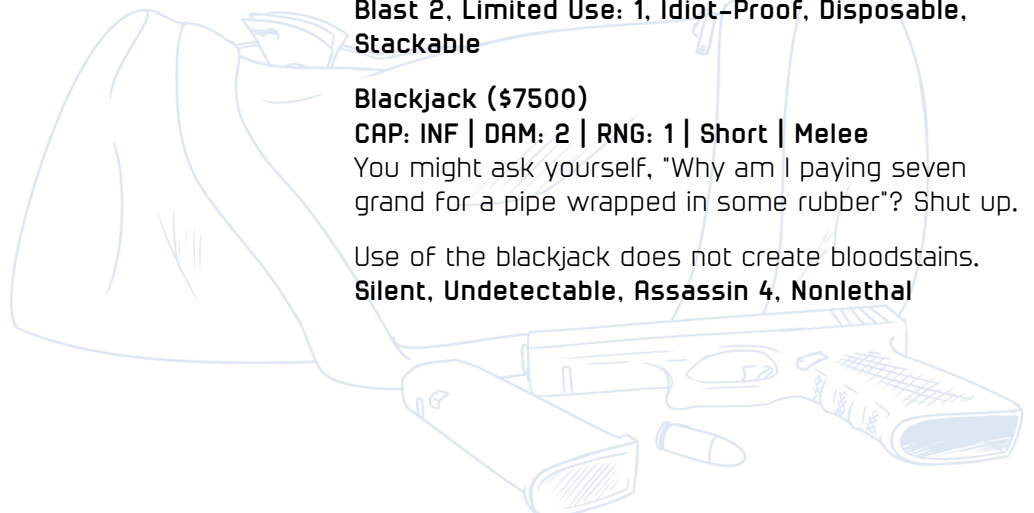

### **Tomahawk (\$7500)**

**CAP: 1 | DAM: 3 | RNG: 10 | Compact  
Thrown, Melee**

Now, the first thing you're probably wondering is whether or not "Tomahawk" is a codename for something, like a missile system or a machine gun or something. It is not. The tomahawk advertised here is a small throwing axe hafted with griffon feathers and traditionally wielded by crazy Indians. You might think this is some useless niche weapon, but that's not quite right. It's niche, yeah, and it strays a little towards the impractical, but it's far from useless. See, getting shot at is all well and good and all, but it's pretty commonplace in this line of work: but if somebody gets a throwing axe stuck in their forehead, that's when people start dropping chocolate.

Whenever you make a kill with a Tomahawk, all enemies with a line of sight to the target suffer a Fear 4/4 effect. Tomahawks may be recovered from the bodies of their victims, if you can hassle the GM into keeping track of where they are.

**Silent, Undetectable, Limited-Use: 4**

### **EXPLOSIVE Tomahawk (\$8000)**

**CAP: 1 | DAM: 5 | RNG: 10 | Compact  
Thrown, Doohickey**

And then the C5 charge inside the axehead explodes, and all bets are fucking off.

**Limited-Use: 4, Blast 1**

### **APSF Shinobi Wristbow (\$5000)**

**CAP: 2 | DAM: 2 | RNG: 7 | Compact | Arrow**

Shooting people in the face with arrows is fun. Carrying around a fancy pneumatic rifle that instantly gets you caught by the police is not. For those of you who don't mind a drop in range and stopping power, the ever-illustrious APSF has released a simple-but-powerful carbon fiber crossbow gauntlet, which can be mounted on the wrist and used to silently deploy multi-purpose arrows at relatively efficient range. This is an ideal weapon for infiltrators attempting to evade metal detectors.

**Silent, Undetectable**

### **APSF Shinobi Garrote Wire (\$10000)**

**CAP: INF | DAM: 0 | RNG: 1 | Compact | Melee**

While knives and bullets are valued for their quickness and versatility, any hit man worth his salt will tell you that they have one fatal flaw: they leave a mess, and that can be the very kiss of death on a stealth mission. For most professional assassins, there's really only one choice for discreet close-range target elimination: a length of quadruple-

twined fiber wire, with two strong grips on either end. While this is absolutely useless in a stand-up fight of any sort, this is a peerless weapon for the sort of person who never gets caught.

The APSF Shinobi Garrote Wire is ineffective against robots. Kills made with this weapon do not create bloodstains.

**Assassin 5, Undetectable, Pierce: Plasteel**

### **Longbow (\$12500)**

**CAP: 1 | DAM: 4 | RNG: 15 | Long | Arrow**

In the medieval era, the longbow was the very pinnacle of weaponry: with significant piercing ability and incredible range, it dominated much of the battlefield. While it was ultimately supplanted by firearms, the longbow has come back in vogue in recent years. In today's paranoid and police-heavy environment, silent and concealable long-range weapons are invaluable; and as a nifty aside, they can be fitted with a large number of special arrows for messy situations.

**Silent, Undetectable**

### **Atlas Sporting Goods Compound Bow (\$17500)**

**CAP: 1 | DAM: 4 | RNG: 12 | Short | Arrow**

For those of you who want (most of) the functionality of the longbow without the social stigma that comes from carrying a deadly weapon around, the Atlas Compound Bow is ideal. Made from an aluminum alloy and created with a multi-hinged design, this little beauty can fold down to backpack size without showing on any metal detectors. While it takes a small hit to effective distance, urban professionals agree: it's worth it.

**Silent, Undetectable, Assassin**

### **Ketamine Belt (\$15000)**

**CAP: 1 | DAM: 0 | RNG: 1 | Compact | Melee**

According to an anonymous survey taken by Electric Eye in 2906, over 70% of thieves and robbers prefer not to kill their targets: not only does it leave bodies to clean up, it leaves you with an awful lot of guilt to deal with. Regardless of whether or not you self-identify as a bloodthirsty psychopath, it is occasionally necessary to leave a target disabled, but alive. Many professionals carry a belt of ketamine-horse tranquilizer-needles underneath their armor. This fast-acting, non-toxic happy juice will leave your target down for the count, and none the worse for the wear.

The Ketamine Belt is ineffective against robotic targets. Its use does not create bloodstains.

**Silent, Undetectable, Assassin 5, Pierce: Plasteel, Nonlethal, Limited-use 6**

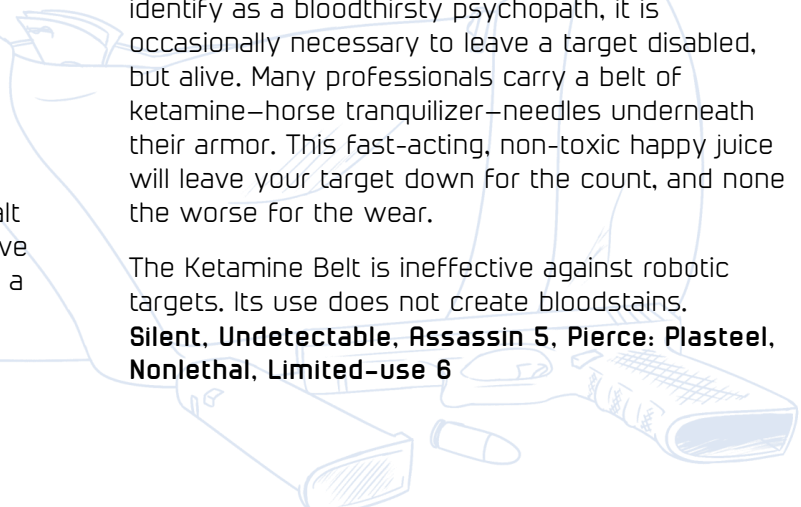

### **Densetsu Designs Tinstar Shuriken (\$12500)**

**CAP: 3 | DAM: 2 | RNG: 8 | Equipment | Thrown**

Historically, metal stars have had two uses: either as a badge of public office in certain parts of South Canada, or as deadly throwing weapons in some parts of Japan; and then, on one fateful day, as part of their ill-fated Western outreach program, Densetsu Designs wed the two. The Tinstar Shuriken is a gaudy-looking badge of the law, which also happens to double as a super-painful throwing knife which excels against unsuspecting and unarmored targets. Plus it's also just really damn cool let's be honest here.

The Densetsu Designs tinstar shuriken does not suffer multi-target penalties. Each shot in its automatic burst may target a different enemy.  
**Silent, Automatic 3, Bleed 3, Limited-use 5**

## **Overcompensating: Shotguns, Machine Guns, Launchers**

### **Thunderbolt Killswitch-20 Shotgun (\$15000)**

**CAP: 5 | DAM: 4 | RNG: 4 | Long | Bullet**

The Killswitch-20 Hunting Shotgun was initially conceived as a weapon for livestock and farm defence. However, its stopping power and stability quickly made it a hit with contractors and criminals alike. Its only notable drawback is also its most well-known feature: its archaic pump action.

**Shotgun 3, Pierce: Mesh**

### **Redstone APL 21-01 (\$25000)**

**CAP: 60 | DAM: 3 | RNG: 15 | Long | Bullet**

By the closing years of 2100, modern rifling had more or less reached its pinnacle. For this reason, most conventional firearms currently in use had already entered production by the year 2050. One exception to this rule is the Redstone Automatic Projectile Launcher 21-01, which first hit production shortly after the RNSM's formation, and very quickly became emblematic of the revolution. With its iconic talon-like tripod and its easy-to-use ammunition box, the Redstone is considered one of the best rural combat firearms in circulation today. It is not only an essential part of the RNSM's military, but a valuable tool for criminals, organized or freelance.

**Automatic 5, Slowloader 2, Heavy**

### **TSD Hurricane Machine Gun (\$25000)**

**CAP: 120 | DAM: 1 | RNG: 15 | Long | Bullet**

Twin Suns Designs, as a company, is uniquely built around the philosophy that a weapon's quality correlates directly to its shots-per-second. The Hurricane is the very epitome of this: while it only chambers .22 rounds, it fires them so rapidly and in such great volume that it can beat down heavily-armored targets through weight of lead alone. It is best used against heavily-armored immobile targets, or quick lightly-armored targets, where its rate of fire is most effective: in ballistic trials against medium targets, it has historically compared poorly to similar weapons such as the 21-01 or the OM2. Even so, it's the most popular support machine gun in the world, for very good reason.

**Automatic 20, Slowloader 6, Heavy**

### **Kessler Thunderball Launcher (\$15000)**

**CAP: 1 | DAM: 4 | RNG: 12 | Short | Warhead**

The subtle approach is usually the best approach. But sometimes, it's just not the one you can take. In those all-too-common circumstances where you just can't keep a low profile, one of the most common and effective tactics is a judicious application of high explosives. In the absence of more powerful ordinance such as fragmentation grenades or rocket launchers, you can always call upon the good old Kessler Thunderball. Initially marketed to police forces, the Thunderball was intended to disrupt riots. Thusly, it only has enough stopping power to kill the weakest of opponents from a single shot; but its comparatively long range and ease of acquisition make it a favorite.

**Blast 1**

### **Kessler Munitions Boomstick (\$5000)**

**CAP: 1 | DAM: 10 | RNG: 15 | Long | Warhead**

Sometimes, not even grenades can satisfy your explosive needs. Sometimes, the only way to properly blow something up is to take a grenade, wrap it in a bunch of steel and black powder, and then affix the entire apparatus to a short-burning rocket. Initially produced during the secession war as a response to Canadian armored units, the Kessler Boomstick has since become an iconic weapon of insurgents, radicals, and ornery old people the world-over! If you really, *really*, want a significantly large group of people dead, this is your gun.

**Blast 4, Disposable, Limited Use: 1, Pierce: Mesh**

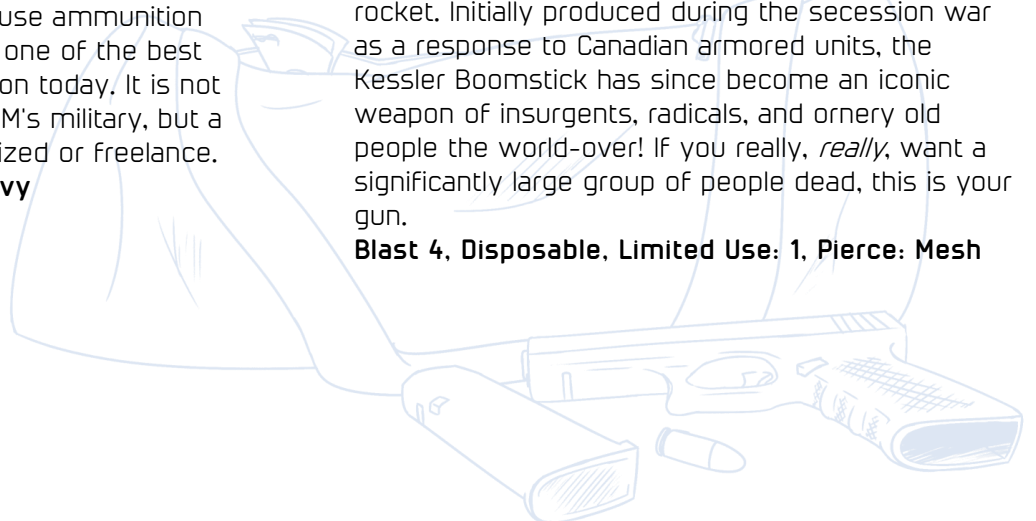

### **Kessler Munitions Mortagorium Mk 3 (\$15000)**

**CAP: 3 | DAM: 3 | RNG: 5 | Long | Warhead**

The best weapons against a numerically superior force are surprise, shock, and awe. Fortunately for hundreds of desert fighters—and a few lucky operators—the Kessler Munitions Mortagorium 3 provides all of them in equal measure. While it is far from the most powerful artillery piece on the market, it's easy to acquire and easy to use, so long as you have a spotter and a place to stand. This means it's perfect for softening up hardened positions, and blasting the shit out of anyone without a good set of armor.

**Blast 2, Artillery, Super Long Range, Slowloader 2**

### **Kessler Munitions Mortagorium Mk 5 (\$75000)**

**CAP: 3 | DAM: 6 | RNG: 5 | Long | Warhead**

The Mortagorium Mk 5 Mortar Launcher is a military-grade artillery weapon which fires bombshells over massive distances and devastate anything caught in the fire. Let's get this real clear: if you are using this gun, you are bad at this job. You have completely failed to understand the meaning of subtlety, you have failed reach your goals with any kind of skill, you lack any degree of criminal acumen, and you are not so much an Operator as you are a terrorist. WHEE do not endorse you or anything you do and in fact actively condemn you and everyone like you for justifying the draconian anti-criminal measures that make our lives a living hell every day. But that being said this gun is hella gnarly.

**Super Long Range, Blast 3, Artillery, Slowloader 2**

### **Snort and Whinny Sawed-off (\$12000)**

**CAP: 2 | DAM: 5 | RNG: 2 | Short | Bullet**

Imagine this for a moment: you're bebopping around Ottawa town just lookin for trouble one day, and all of a sudden you realize your shotgun has too many ammunitions and not enough murders. You don't want a weak little boomstick like the ministry uses, you want a real man's shotgun—something so loud and so strong that you'll break your wrist just firing it, and everyone within three blocks will know you did it! If you've ever had a thought like that before, you're in luck: with this simple monolimbic leadspitter, you can pump your enemies full of so much shotshell that if they survive (which is unlikely) they'll be shitting bullets for weeks to come. Just make sure you don't miss: this thing has next-to-no range, and a capacity to match.

**Shotgun 5, Automatic 2, Slowloader 2,**

**Pierce: Mesh**

### **Snort and Whinny Compact Shotgun (\$10000)**

**CAP: 1 | DAM: 5 | RNG: 3 | Compact | Bullet**

Yeah ya know it's basically the Sawed-off only shorter and shittier.

**Shotgun 3, Undetectable, Slowloader 2**

### **APSF Pocket Flamer (\$15000)**

**CAP: 1 | DAM: 1 | RNG: 5 | Compact | Chemical**

This little baby isn't much to look at, which is really the point. While on the surface it appears to be a halfway-functional watch, this little baby is actually a single-use wrist-mounted flamethrower, which can—discharge a small (but effective) gout of flame. The ammunition packets on this thing are so small you can easily carry six or seven dozen inside your ears and nostrils.

**Burn 2, Cone 5**

### **Kessler Munitions Flamespitter (\$20000)**

**CAP: 5 | DAM: 3 | RNG: 6 | Short | Chemical**

The Maim-and-pillage approach has always has its uses, but it's usually pretty hard to dish it out. You can't use rockets and bombs in close quarters, and bullets—for all their uses—don't burn the shit out of everything in sight. For those of you who require a pleasant middleground between precision and purgation, there is an answer: the Kessler Munitions Flamespitter. Pioneered during The Second Dark Age, the Flamespitter is one of the oldest weapons in the modern world; and three hundred years of refinement have been kind to it. Flamespitter is capable of flooding tight corridors and spaces with gout after gout of red-hot fire. While the technology has been duplicated (and arguably improved upon) by many, the Kessler model remains the number one choice for Operators and National Guardsmen, owing to its portability and ease of use.

**Burn 5, Cone 2**

### **Kessler Munitions Barnburner (\$50000)**

**CAP: 12 | DAM: 6 | RNG: 9 | Long | Chemical**

After winning the secession war, the RSNM-Backed Kessler Munitions continued developing their proprietary incinerator technology, specifically for use in its pit-cities. It was discovered some years later that the continued development of subterranean combat tools was in fact the result of the RSNM's ultra-nationalistic "bug hunt" initiative; but don't let the taint of racism cloud what is otherwise an amazing implement for lighting people on fire. The Barnburner is a twin-tanked beauty of a burner, with enough range to char an entire room.

**Cone 3, Burn 6**

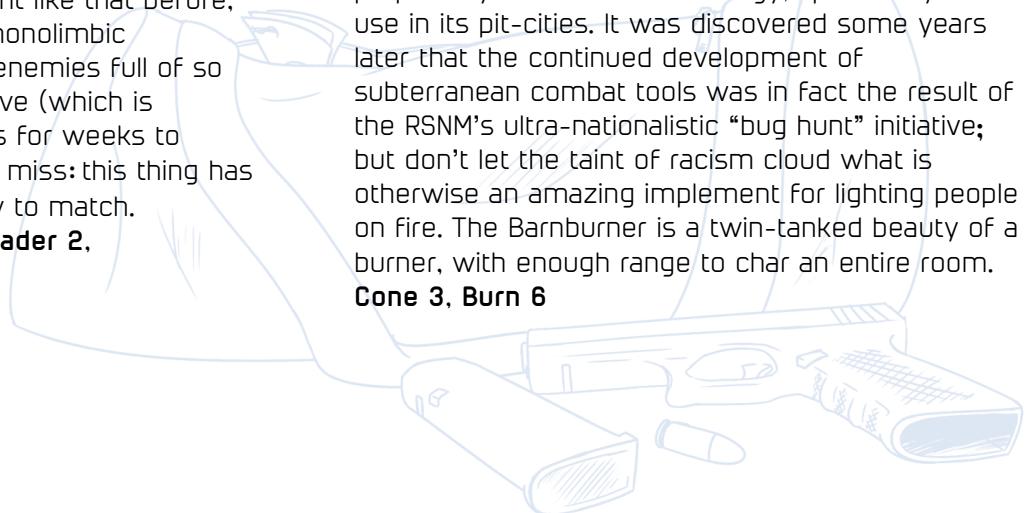

### **Tartarus Fragnet Launcher (\$15000)**

**CAP: 20 | RNG: 15 | DAM: N/A | Short | Warhead**

The Fragnet Launcher is one of the most horrible things ever made: a weapon that is capable not only of reducing men to smears in the space of seconds, but does so just slowly enough for them to comprehend the horror of their situation. While it might not look like much, with its simple slingshot-like design, the Fragnet launcher is actually quite advanced. It fires a number of spiked explosive charges, all of which fly approximately as fast as bullets, and are leashed together via an electromagnetic coil. After being fired, the charges can dig into flesh (and most other materials) with its spines; and thereafter, the magnetized coil will wrap around itself around the victim with the force of a vice, and detonate several seconds later. Unfortunately, due to its large charges and complex firing mechanism, a Fragnet Launcher cannot be reloaded once it's been taken into the field: and while it's cheap and easy to make, doing so is banned under the Wasteland accords.

Regardless of how many bullets are fired in a single barrage, a Tartarus Fragnet Launcher is always treated as though it is only making one attack. The damage of this attack is equal to the amount of ammunition expended to make it. The Tartarus Fragnet Launcher cannot target more than one target.

**Limited-use: 1, Disposable, Pierce: Plasteel**

### **Thunderbolt Assault Shotgun (\$35000)**

**CAP: 12 | DAM: 4 | RNG: 10 | Long | Bullet**

After Thunderbolt began developing weapons specifically for military use, it did not take them long to move into CQC. Enter the Thunderbolt Assault Shotgun: a veritable death-spitter of a machine, which combines the best characteristics of an assault rifle—light weight and low recoil—with those of a shotgun. The TAS is capable of automatic shotshell fire, and has one of the largest magazines of any shotgun on the market. However, it does suffer from limited range; and the compact shells that are loaded into the weapon are incapable of piercing armor. For this reason, the TAS is most commonly used as an insurgent suppression or SWAT weapon, as neither group is likely to be armored in any considerable capacity.

**Shotgun 2, Automatic 2**

### **Tartarus Radcannon (\$115000)**

**CAP: 5 | DAM: 10 | RNG: 7 | Long | Energy**

Synonymous with cruelty, horror, and the all-consuming wickedness which people are capable of, the Tartarus Radcannon uses a combination of directed microwaves and laser spinerettes to create a uniquely deadly weapon. It's capable of bathing a small area in lethal doses of microwave radiation—which will almost invariably cause plants to combust, tile to scorch, and flesh to slough off and straight-up explode. The Radcannon was exclusively employed during Vietnam 2, and thereafter banned under the Wasteland accords.

**Heavy, Radiation, Slowloader 2, Cone 2**

### **Thunderbolt Munitions Large Explosive Weapon Device (\$50000)**

**CAP: 1 | DAM: 10 | RNG: 15 | Long | Warhead**

While coasting by on a steady diet of boomstick tubes and grenades might be good for a casual explosives expert, a serious operator who faces serious threats will, sooner or later, have to blow up a tank, chopper, or suit of powered armor; and when that day comes, nothing in the world is preferable to a rocket launcher. Unlike the boomstick or more simplistic RPG's, this baby fires guided self-propelled projectiles that are capable delivering larger payloads across greater distances than many other weapons of its kind. It'll run you a pretty penny, and it's difficult to carry the ammunition for it; but for superheavy jobs, one of these is practically essential.

**Blast 3, Limited-Use 2, Pierce: Ceramic, Slowloader 4**

### **Kobutodo-Z SGA Shotgun (\$20500)**

**CAP: 1 | DAM: 5 | RNG: 5 | Long | Bullet**

Whatever else can be said about the Neokong—and MANY things can be said about the Neokong—at least they knew how to kill someone damn well. For proof of that, you need look no further than the "Chinese Broom": the gun that was so called because of the numerous atrocities it was used to commit against the Chinese in Vietnam II. This is a single-shot 10-gage shotgun with a wide mouth, designed to load special overstuffed shotshells; and on top of this, it used a simple application of then-nascent energy weapons technology to set each pellet on fire as they were discharged.

**Shotgun 2, Burn 3, Cone 2, Blast 1, Slow-load 4, Pierce: Ceramic**

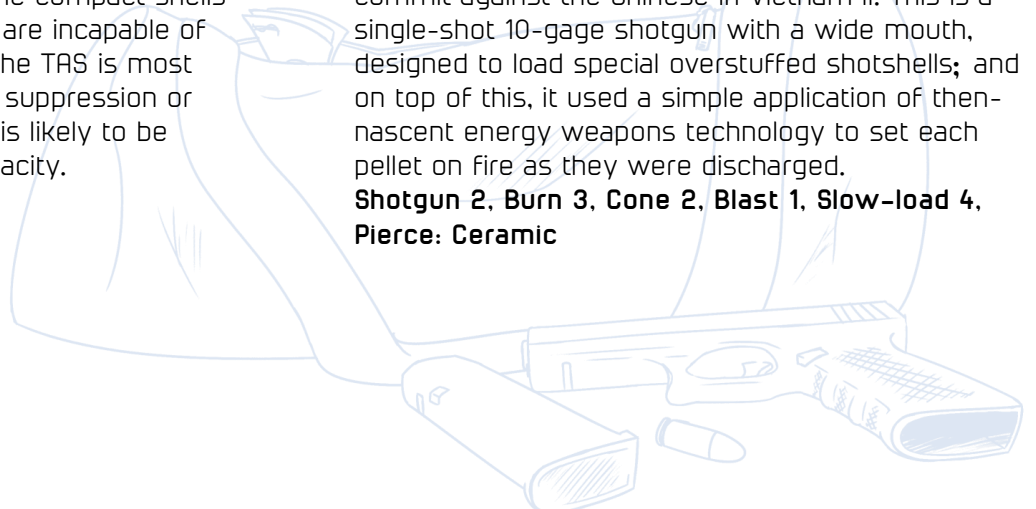



### **Kessler Munitions GL41 "Tube Full of Fuck" Grenade Launcher (\$25000)**

**CAP: 4 | DAM: 0 | RNG: 20 | Large | Warhead**

One of the many unfortunate realities of heavy demolition is that grenades are large, heavy, and generally difficult to throw. For most operators who weren't previously baseball pitchers, that means that grenades are of limited use—hence the creation of grenade launchers. Simple devices such as these consist of a revolving cylinder and as simple spring-based firing mechanism, which can be loaded with the majority of grenades on the black market, and thereafter fired a very great distance into your enemies' fat dumb faces. Isn't that great?

The Kessler Munitions GL41 Grenade Launcher does not do any damage on its own, but may load any item with 'grenade' in the name. The GL41 gains the damage and traits of any grenade loaded, keeping its capacity and range. You can load grenades from multiple belts in alternating order if you are so inclined, but the GM will surely loathe you.

### **Snort and Whinny Break-Action-Damage-Augmenting-Superior-Sidearm (\$25000)**

**CAP: 6 | DAM: 4 | RNG: 8 | Short | Bullet**

Ooooh baby. If you want to talk about a gun for collectors, this one's the daddy of them all. The S&W Break-action-you-know-the-rest is the ultimate museum piece, for practical and historical reasons: not only was it the very last gun Papa Pushyuu saw put into syndication, this little beauty was designed with built-in inktek circuitry that was years ahead of its time. The long and short of it is that this unassuming six-shooter turned out to benefit from an inky firing system which can "charge" bullets by using a low-intensity gag to increase their power.

While you have the Snort and Whinny Break-Action-Damage-Augmenting-Superior-Sidearm equipped, you may spend any number of actions twirling it in your grip. For every action spent doing this, the damage of every bullet left in the clip increases by 1, up to a maximum of 10. Only actions spent spinning the revolver **after** a given combat encounter has begun count towards this; and anything revolver-twirling before combat begins does not increase your damage.

**Recoil 4**

### **APSF Schultz-Pattern Coach Cannon (\$12500)**

**CAP: 1 | DAM: 4 | RNG: 4 | Compact | Bullet**

Have you ever felt the overwhelming need to shoot someone with a really big gun, while also being in a position where you can't easily hold one? Don't lie, of course you have; and the mad geniuses at APSF have you covered. The Schultz-Pattern CCC is a wrist-mounted easily-concealed rail-pistol, which is capable of recoilless launching a bullet with considerable velocity. Unfortunately, it only holds one round, takes ages to reload, and it has a range so small you'd probably be better off just stabbing the guy. The CCC is thusly suitable only for one thing: pretending to shake a guy's hand, and then shooting him in the head instead.

**Pierce: Plasteel, Slowloader 2**

## **One Shot, One Kill: Sniper Rifles, Nothing But**

### **Thunderbolt G30 (\$25000)**

**CAP: 5 | DAM: 6 | RNG: 25 | Long | Bullet**

While Thunderbolt initially catered to farmers and frontiersmen, they didn't stay out of the military game for long; and soon they were selling a wide array of dedicated soldiers' equipment to anyone who would buy. Their flagship product was the Thunderbolt GXX line—a series of anti-material rifles with superior range and stopping power, that were capable of doing some truly terrible things to just about anything they were pointed at.

**Heavy, Slowloader 2, Pierce: Ceramic**

### **LunaSea Scout Rifle (\$17500)**

**CAP: 6 | DAM: 4 | RNG: 15 | Long | Bullet**

While the Thunderbolt company typically claims absolute dominion over long-range weaponry, companies such as LunaSea and Swhinny are by no means forbidden from offering their own take on it. Thus, we have the LunaSea Scout Rifle—a .28 caliber rifle which has been fitted with a massive two-in-one flash and sound suppressor. The result is a rifle that doesn't do much damage and doesn't have much range, but it barely makes any noise at all. This is an ideal weapon for anyone providing overwatch in an urban area, who's fearful of attracting attention.

**Suppressed**

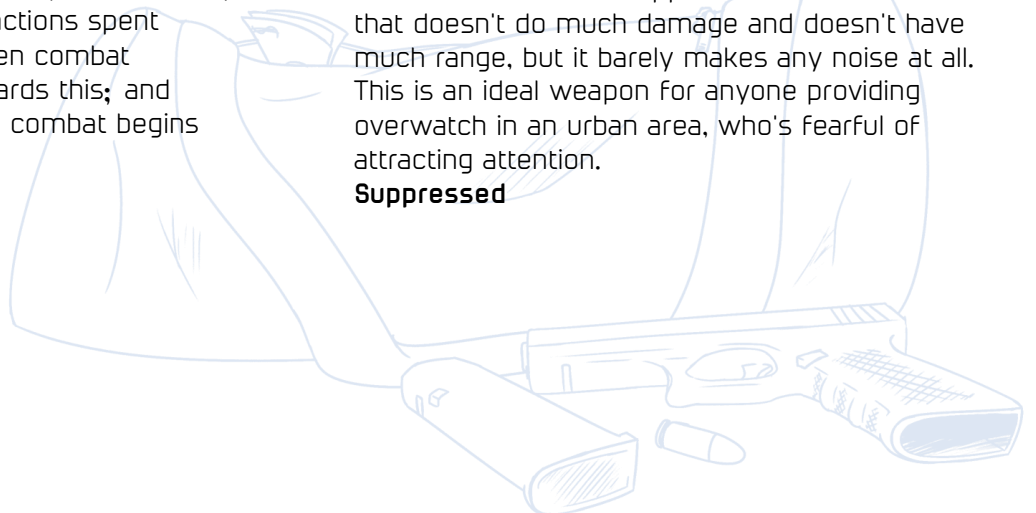

### **Thunderbolt Muni. Bullhammer Rifle (\$15000)**

**CAP: 5 | DAM: 6 | RNG: 15 | Long | Bullet**

The Second Expansion was characterized primarily by lawlessness, patriotism, and racism. Case in point: the Thunderbolt Bullhammer. While modern press releases say the Bullhammer and its various sequels and spinoffs were named because they "hit like a bull and a hammer at the same time", more educated perspectives contend that it was designed specifically to be able to kill minotaurs and other inky bovines. While it can't really do that anymore, due to advances in body armor, the Bullhammer is still an excellent marksman rifle, which benefits from considerable stopping power and range—plus peerless mobility, for its caliber.

**Recoil 2**

### **Thunderbolt Stratus-class Rifle (\$75000)**

**CAP: 2 | DAM: 9 | RNG: 25 | Long | Bullet**

When the Thunderbolt company discontinued their GXX line in the late 90's, they cited decreased interest in the product. This was, in fact, PR bullshit worthy of a McMahon—the real reason the GXX was continued was because of a copyright dispute which they company settled quietly and out of court. After cannibalizing their flagship product, the Thunderbolt company proudly unveiled the Stratus-Class anti-personnel rifle. It is now a favorite of competition shooters and snipers everywhere—because even though it may get kind of bendy after a few hundred shots, it leaves an exit wound the size of a cinderblock.

**Heavy, Pierce: Ceramic, Slowloader 3**

## **Swords and Boards: And Tasers, and Spears, and Other Stuff Too**

### **Pocket Sand! (\$500)**

#### **Equipment**

When some crazy samurai, ninja, or liberal comes at you swinging their swords, fists, or fliers, you can swing something right back: a handfull of fine-grade sand, designed to get in their eyes and fuck up their shit!

After taking damage from a weapon that has exclusively the Melee damage type, you may expend your Pocket Sand! to nullify the effects of the attack.

**Limited Use: 1, Disposable**

### **Kapricorn Zeus-Pattern Stunsticks (\$3500)**

**CAP: INF | DAM: 4 | RNG: 1 | Compact | Melee**

A number of close-combat engagements, particularly those within urban centers, are held with the intention of capturing rather than killing. The Kapricorn Corporation, though they primarily produce swords, is aware of this; so they've put a number of nonlethal melee products to market. The most popular of these is the Zeus-Pattern Stunstick: a club, with two protrusions on either side, which carries a voltage of approximately seven thousand volts.

**Nonlethal**

### **APSF Belmont-Pattern Whip (\$7500)**

**CAP: INF | DAM: 3 | RNG: 6 | Compact | Melee**

What kind of sick, dirty, perverted bastard uses a WHIP in combat? I mean God damn it's not even an effective weapon, it just HURTS. That's fucking mean, fuck man. You need some fucking help you weird sadomasochistic bondage queen Ohio Smith motherfucker god damn what is wrong with you.

...S'got a good reach, though.

**Undetectable**

### **Kapricorn Sonic Blade (\$25000)**

**CAP: 6 | DAM: 4 | RNG: 1 | Long | Melee**

Since their inception, the majority of swords have been made out of iron or steel, due chiefly to their durability and ease of acquisition. The Kapricorn Sonic blade, however, is made of *aluminum*—which is significantly lighter and less dense than steel, and therefore far more likely to bend and warp—but this weakness in material is an unfortunate necessity. As it happens, the primary strength of the Sonic Blade is not in its cutting power, but rather its ability to *vibrate*: each Kapricorn Sonic Blade is built around a powerful kinetic emitter, which causes it to vibrate at the resonant frequency of steel. This allows it to move through even the thickest of infantry armors like a knife through butter; and, to ensure that it does not become unusably dull after a few strikes, each Sonic Blade can be ejected from the hilt and replaced with another blade from its holster, several of which are included with every purchase.

When you reload the Kapricorn Sonic Blade, pick a target within 5 squares of you. You may make an attack against that target at 5 damage with pierce: plasteel.

**Pierce: Plasteel**

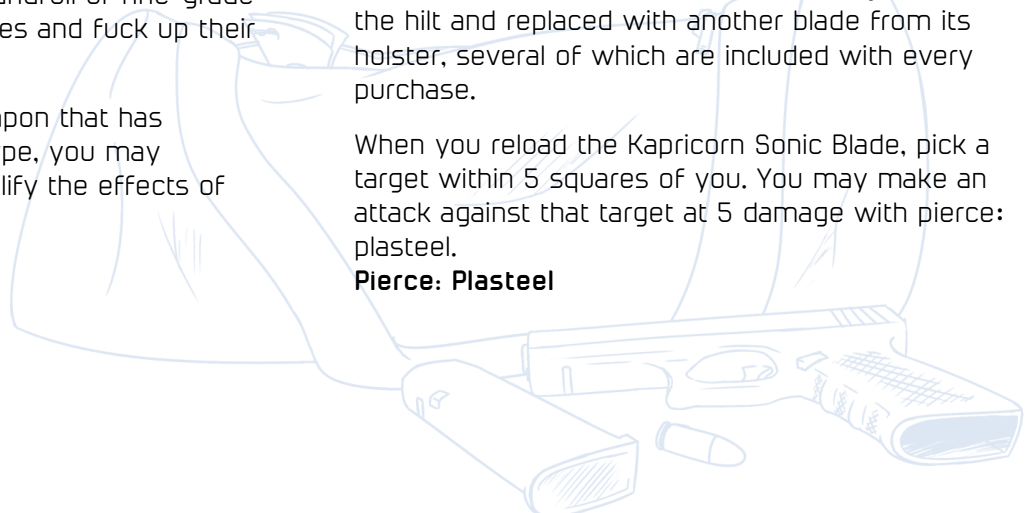

### Kapricorn Longsword (\$15000)

**CAP: INF | DAM: 6 | RNG: 1 | Long | Melee**

The Kapricorn Frontline blade was a success—a bit too much of a success, really. While Kapricorn expected a healthy demand for soldiers in need of a melee weapon, they did not anticipate the resurgence of dedicated swordsmen. Colloquially known as "Fucking Idiots", these modern samurai dance with death whenever they take up arms. However, just because a market lacks common sense does not mean they lack money; and so, within five years, Kapricorn unveiled a new and improved model of their iconic frontline blade—one that boasts superior weight and strength, all for a nominal 1000% increase in asking price. You might say "That's an absolutely ridiculous financial model"; but everyone who matters is going to say "Ooh, shiny!"

**Pierce: Ceramic**

### CorpTechs SD-420 Cordless Drill (\$12500)

**CAP: 15 | DAM: 3 | RNG: 1 | Short | Melee**

The cordless drill is a wonderful invention, and you've likely had cause to use one in your life at least once. You might've had to tighten some screws or fix a hinge or something similarly innocent. The point is, you probably never used one to drill a guy's fucking skull in. Given that you're reading this book, that may be about to change. The CorpTechs SD-420 cordless drill is a lightweight beast of an appliance, which has a pitiable battery life that's offset by the fact that it can mount industrial-grade diamond bores with minimal wrist strain, thanks to the clever addition of a wrist brace and an optional foregrip. While its intended purpose is to allow you to drill through construction supplies, let's be honest here—at some point in your career, this is going into a guy's face.

The CorpTechs SD-320 Cordless Drill can be used to drill through walls up to 1 tile thick; you cannot pass through the hole it leaves, but you can see and hear through it and pass small objects through it. It may be used to drill through doors that are locked mechanically or electronically; this is treated as a **suppressed gunshot** for purposes of noise, and always takes two actions. Every time a CorpTechs SD-420 Cordless Drill makes a successful attack against an armored opponent, its base damage is increased by 3 against that target. If a CorpTechs SD-420 Cordless Drill attacks with a base damage greater than half an enemy's maximum armor, it will **instantly incapacitate** its target. This does not occur if the target does not have an armor score.

**Limited Use 1, Spin-up 1**

### Atlas Captain–Pattern Shield (\$20000)

**CAP: INF | DAM: 4 | RNG: 1 | Equipment | Melee**

When Atlas Outfitting prepared to tackle the combat paradigms of the Doubleearth, it became obvious from the get-go that most of their ideas about corporeal shielding would have to change, and rapidly. With the proliferation of inkstuff, flexibility was more important than ever; and so they started from the ground up with a brand new vision. A shield for the modern age needed to be made of plasteel—and more importantly, would be built with a new circular shape to allow the wielder a wider vision cone. Thus, the Captain–Pattern Ballistic Shield was born; and though it requires a great deal of coordination and foresight to use effectively, it is such a fine piece of equipment that it has become emblematic of spec ops and superheros around the country.

While the Captain–Pattern Ballistic Shield is equipped, you may spend one action per turn to attempt to block all incoming fire from any given facing. Whenever you are attacked from that facing during that round of combat, you must make an athletics roll, with a stacking -1 penalty applied for every 7 bullets deflected this way; and additionally, while blocking, you may adjust your facing **once** at no action cost. If you fail a roll, your guard will be broken, and you can be damaged normally. If the Captain–Pattern Ballistic shield ever takes damage from a source that does 15 or more damage in a single instance, you may make the deflection roll normally, and then it will shatter regardless of your success and become useless until the end of the mission.

While wielding the Captain–Pattern Ballistic Shield, you may not use any long weapons, but may use any short or compact weapon, and make clash rolls where appropriate. You may, if you are so inclined, attack with the Captain–Pattern ballistic shield as though it were a weapon, without incurring a weapon switch penalty, or multi-shot or multi-target penalty incurred from using another weapon on that turn.

### Nunchucks (\$15000)

**CAP: INF | DAM: 4 | RNG: 1 | Short | Melee**

Let's be honest with ourselves. You might wear a mask, and you might call yourself a street samurai, and you might even be Japanese; but you know, deep down, you're not a *real* ninja. You're not a real ninja until you have a pair of *nunchaku*—but, good news, such things are easy to buy. Consisting of two lead weights wrapped in rags and joined by a

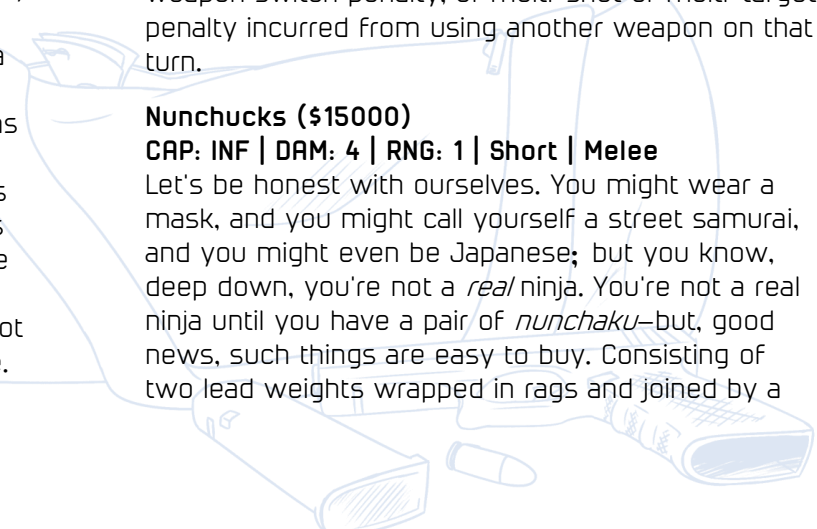

chain, nunchucks are ridiculously difficult to wield properly, to the point where they have become synonymous with legendary martial arts prowess. Fortunately for you, you don't need to use them properly in order to just club the living daylights outta some loser.

While you have the nunchuks equipped, you may spend any number of actions spinning them. For every action you use spinning the nunchucks, their damage increases by 1, to a maximum of 8. After making an attack, this number will reset if you spend one turn without making an attack action.

#### **Nonlethal**

#### **Snort and Whinny Blast Shoes (\$5000)**

**CAP: 1 | DAM: 0 | RNG: 1 | Compact | Melee**

While Snort and Whinny is primarily known for its firearms, they are not entirely unwilling to branch out from time to time. One such example is the Blastshoe—which underperformed spectacularly, and is thusly seldom found. It's simple enough—it's a horseshoe with a series of shaped thermal charges in the hobnails. While this is highly impractical and highly dangerous, the effects cannot be denied: if you punch someone with this, you'll knock their shit in.

When you use make an unarmed attack while wearing the Snort and Whinny Blast Shoes, you may choose to spend one of its uses. If you do, that attack does double-damage, including all pre-existing damage bonuses from augmentations or other sources.

**Limited Use: 3**

#### **Tartarus Magina–Pattern Glaives (\$15000)**

**CAP: INF | DAM: 6 | RNG: 1 | Short | Melee**

While the modern Tartarus Company is chiefly focused on wasteland survival, they haven't forgotten their demoniac origins—and they're fully prepared to go hand-to-hand with it. The Magina–Pattern Battle Glaives were designed to specifically disrupt magic while being as violent as possible. These blades are ridiculously heavy and unwieldy owing to the density of their material, but they make up for it by being easy to conceal and borderline unbreakable. Plus, the magic-inhibiting runes etched into them will fuck sorcerers UP. If you ever think you're about to have to fight a demon (and God help you if you are), bring one of these.

**Heavy, Pierce: SPC, Pierce: Mesh**

#### **Spear (\$25000)**

**CAP: INF | DAM: 4 | RNG: 3 | Long | Thrown, Melee**

A spear! Oh my God! Whether you're a hoplite killing literally Christians in an arena, or a huge guy figuratively killing Christian in a different arena, a spear is a great weapon to call your own. With stopping power comparable to a sword and range that outmatches most other melee weapons, it can dominate close-quarters; and with a shield and some clever positioning, it can turn desperate one-on-ones into piss-easy battles of attrition. This modern model is made of plasteel and wrapped in pleather, for maximum comfort and ease of use; and, rather fittingly, many modern spears come with an air compression chamber and a short-range winch in order to help you hurl these things at subsonic speed at whatever it is that's pissed you off.

Attacks made in the spear's first and second range increments do 8 damage with pierce: ceramic; however, you **must spend an action** to reel it in before you can use it again. Attacks made in the spear's third range increment do 12 damage with pierce: plasteel, but you must go to its target in order to pick it up again.

**Pierce: Mesh**

## **Special Guns for Special Moments: Mediguns, Lasers, Holdout Guns**

#### **Hashimoto Lasblaster LB-1 (\$5000)**

**CAP: INF | DAM: 2 | RNG: 10 | Short | Energy**

The general consensus among professional combatants is that energy weapons are niche at best, due to their specific application requirements—being really effective only on hard targets. Be that as it may, they're almost peerless in that particular role—and the LB-1 is the most common energy weapon in production today. Consider getting one.

**Laser**

#### **Hashimoto CD-LT Assault Rifle (\$7500)**

**CAP: 20 | DAM: 2 | RNG: 12 | Long | Energy**

Hey, ever wanted to be a space marine? With the CD-LT, you basically can! This modification package comes with a long barrel, a rotary foregrip, and an auxiliary weaponry pack that houses a self-venting plasma generation chamber. The end result of this is a bona-fide blaster rifle!

**Automatic 4, Laser**

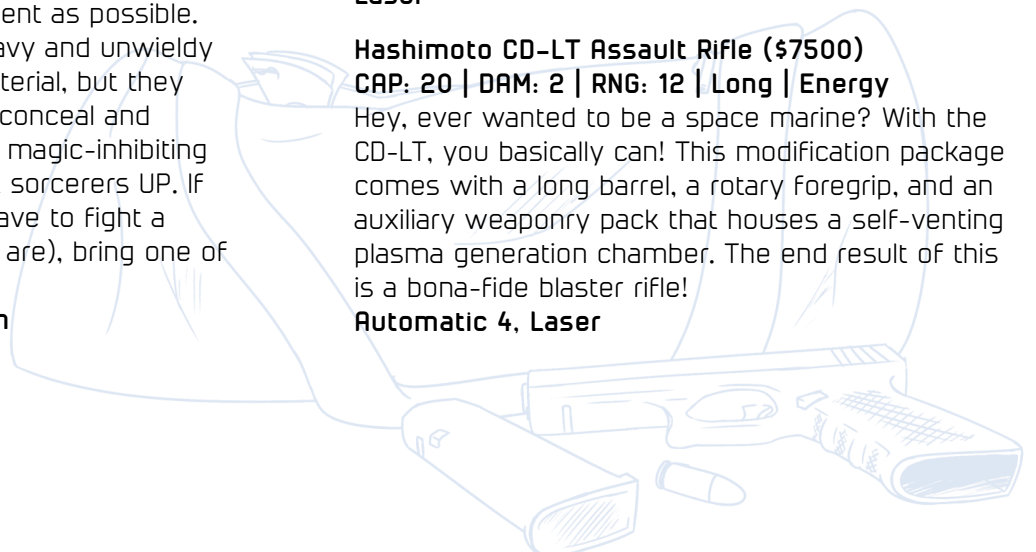

### Hashimoto "Headshock" Heavy Pistol (\$7500)

**CAP: 10 | DAM: 4 | RNG: 8 | Short | Energy**

As it turns out, a super-high-capacity battery can be put to relatively good use: in this case, by powering a low-intensity directional microwave array designed to shock, stun, and disorient opponents, with only prolonged exposure being lethal. While the Headshock was originally intended for Japanese SWAT teams working on well-equipped targets, it found a home among kidnappers and ransom-takers around the world for its intensely painful (but nonlethal) discharge.

**Radiation, Nonlethal**

### Hashimoto "Hotgun" Armor Removal Tool (\$7500)

**CAP: 4 | DAM: 2 | RNG: 4 | Short | Energy**

For those of you who like shotguns, but think they'd be better if they were laser-powered and chrome-plated...you're lame. And you should buy this gun cuz it's basically that.

**Laser, Burn 2, Shotgun 4**

### Hashimoto "Spot'n'Spark" Sniper (\$7500)

**CAP: INF | DAM: 4 | RNG: 25 | Long | Energy**

If you're the sort of marksman who uses laser sights on your weapon—as dubiously efficient as they are—you have no doubt spent at least some length of time imagining that your laser is some kind of long-range blowtorch while going "Prrrrssssht". With the miraculous advances of modern science, those extremely specific fantasies can become and extremely specific reality! With the addition of half a meter's worth of magnifying lenses and a cylinder full of miniature turbines, it is capable of augmenting a laser to a truly frightening level of power and precision.

**Laser, Burn 2, Heavy**

### Tartarus Adraste-Pattern Crossbow (\$12500)

**CAP: 2 | DAM: 2 | RNG: 8 | Short | Arrow**

It's long been accepted as fact that large pointed projectiles are the best way to hunt mutants: Not only do they wreak absolute HAVOC on muscle tissue and bone, they open massive gaping wounds and often pin their target in place. However, not everyone has the time or the skill to operate one of those massive winch-powered monstrosities—sometimes you need a smaller, lighter, spring-loaded weapon—the kind that has a second bolt ready to go right after the first one. If you're one of those people, you need an Adraste-pattern crossbow: with no recoil and very little weight to speak of, this is perfect for mutant hunters, or one-armed bandits.

**Pierce: SPC, Bleed 3**

### Hashimoto AP2 Atomic Cannon (\$25000)

**CAP: 1 | DAM: 10 | RNG: 15 | Long | Energy**

So sometimes a regular laser can't cut it. Sometimes you need a cannon the size of a tractor that can punch a hole through a LEETR, the house standing behind it, and the tank parked behind THAT. Turns out, lasers can do that too. Well, they can do that as long as you don't mind carrying around a modular tripod and hoverskiff (plus two additional power packs, one set of straps, a set of optics, a 'drum barrel' turbine, and an inflatable flamingo).

**Slowloader 4, Laser, EMP 2, Heavy, Spin-up 2  
Burn 2, Cone 5**

### UA Wunderpistol (\$5000)

**CAP: 10 | DAM: 2 | RNG: 10 | Short | Bullet**

In 2299, UA Munitions—that bastion of fine German engineering—sought to redefine ballistic combat: "a new paradigm for a new age", they called it. The idea was simple, yet daring: using the power of computers and servos, they'd create a pistol that could aim and fire itself. The result of this venture was the UA Wunderpistol, which almost instantly acquired a bitter legacy: shunned by sport shooters for its lack of skill and by the military for its low range and firepower, the Wunderpistol was almost exclusively used by spree shooters and serial killers. While the Wunderpistol was discontinued, imitations and refits are common among operator crews.

**Targeting Software**

### Hashimoto MAGDAR Mk 2 (\$5000)

**CAP: INF | DAM: 0 | RNG: 30 | Short | Doohickey**

The best weapon doesn't always kill—sometimes, the most powerful weapon a guy can have is the element of surprise. With the Hashimoto MAGDAR, you can easily rob your enemies of that, and potentially avoid walking into a deadly ambush. Consisting of a simple high-powered directional Magnetic Detector and a video screen, the MAGDAR is capable of detecting magnetic materials through clothing and fur, and relaying the information directly back to you—not only does this let you see exactly who has the time, it lets you see who's packing heat.

When you use the Hashimoto MAGDAR against an enemy, you are able to see any weapons they are carrying, which do not have the **Undetectable** trait.

**Idiot-Proof**

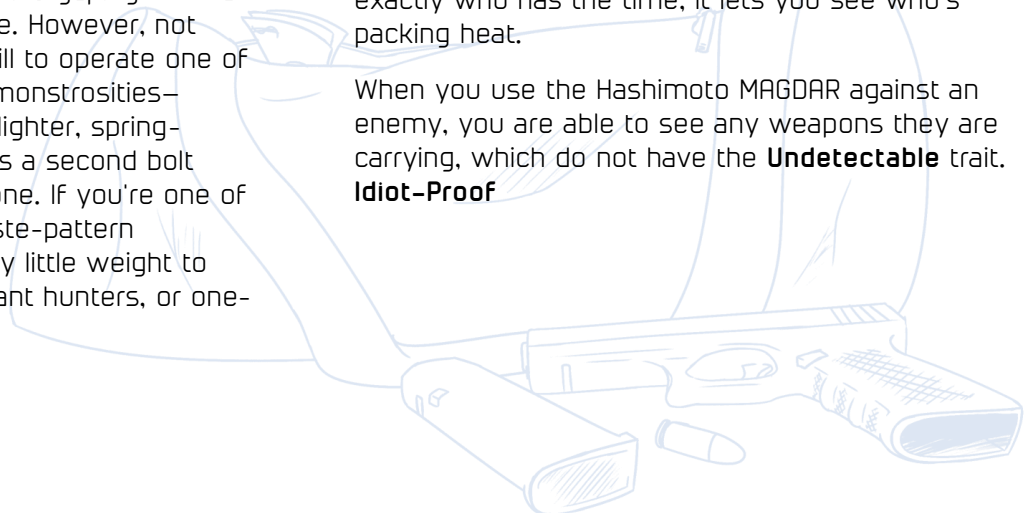

### **Squeezebox (\$7500)**

**CAP: 8 | DAM: 0 | RNG: 0 | Equipment**

Ah, the squeezebox—the most jovial of all squeezable instruments, narrowly beating out the bagpipes and the Otamatone. It's the perfect thing to play at polkas, at romantic getaways in Venice, and at funerals; it's what you use to keep your spouse awake at night; and anyone who can play it, even in passing, can easily arouse a gleeful melody of such tremendously light spirits that even the most awful of terrors will fly before it. Grab a squeezebox and squeeze away!

The Squeezebox completely neutralizes any and all fear effects in its area of effect.

**Blast 5, Limited-use 1, Heavy, Idiot-Proof**

### **DivSys Stem Cell Sprayer (SCS) Mk. 1 (\$35000)**

**CAP: 3 | DAM: N/A | RNG: 4 | Long | Doohickey**

In the early 2200's, almost a full 7% of surgical complications occurred as the result of improper tissue bonding in the immediate aftermath of augmentation. The results were ghastly: necrosis, gangrene, augment rejection—it was something of an epidemic. This was ultimately solved with a complex piece of medical technology, which is at the same time simple to explain: by combining specially engineered rapid-maturing stem cells with a modified swarm of medical nanobots, it was possible to create a "Healing gun" that rapidly and (semi)safely regenerated its target's tissue in a very small amount of time. While current augmentation technology has outmoded it, Stem Cell sprayers remain indispensable in hospitals and military bases the world over.

The Divinity System Stem-Cell Sprayer always fired using Field Medic. Upon a successful discharge, all units within the affected area instantly heal up to their nearest third.

**Cone 2, Slowloader 4**

### **Hashimoto Wave-Form Cannon (\$25000)**

**CAP: INF | DAM: 2 | RNG: 16 | Long | Energy**

Have you ever wanted to shoot everything—and I mean EVERYTHING, no ifs ands or buts—that you can see with a wave of high-intensity laser light? Well then, you need the Wave-Form Cannon modification and all of the widgets, wingdings, and doodads that come with it. Just find a pleasant place to camp, set this bad boy up, and get ready to take a shit on every robotic, tank, and well-armored huge guy that comes at you.

**Laser, Automatic 4, Cone 2, Heavy, Spin-up 4**

### **Divinity DivSys SCS Mk. 3.0 (\$35000)**

**CAP: 1 | DMG: N/A | RNG: 10 | Long | Doohickey**

After the *disastrous* release of the Divinity Systems SCS 2.0, the developers took it back to the drawing board and back to basics. After approximately ten seconds, it was determined that one of the big problems that the Mk.1 and 2 shared was a tremendous imprecision: given that they were practically vaporous, things got very messy and very unsightly very fast. Thus, the decision was made to refine the application method: instead of a big honkin cloud of gas, the 3.0 distributed its stem cells through small globs of self-guiding nanobots, which are capable of guiding themselves around corners and over great distances. Reportedly the original design called for a steady beam of medicine, but this was quickly abandoned after the project's head technician was scalded to death by a corporate assassin.

The Divinity System Stem-Cell Sprayer is always fired using Field Medic. Upon a successful discharge, the targeted unit will instantly heal up to their nearest third.

**Artillery, Slowloader 2**

### **CorpTechs Marston-pattern Lasso (\$7500)**

**CAP: INF | DAM: 0 | RNG: 15 | Short | Doohickey**

The tradition of sport lasso emerged shortly after inkstuff made it possible to contort rope in ways that physics did not previously allow. Shortly after, the lasso found use as a combat utensil—primarily during SWAT operations, or during kidnapping operations by enterprising operators. While one of these can't exactly stand in for a gun, it certainly has its uses...

When you successfully attack a target with a lasso, move the target a number of squares directly towards you equal to your athletics score. The target may choose to resist if they are so inclined, by making an athletics roll that suffers a -4 penalty for every move action they made on the previous turn. Using the lasso counts as using equipment, and thus does not consume an attack action.

### **Hashimoto Projectile-Redirecting Electromagnetic Projector (\$25000)**

**CAP: 1 | DAM: N/A | RNG: 5 | Equipment Energy, Thrown**

Hashimoto has historically styled itself as belonging to a "more elegant school of combat". While this elegance usually manifests as a laser weapon, or an energy projector, or some other futuristic gadget, they must—begrudgingly—acknowledge the prevalence of conventional ballistics: and, for the

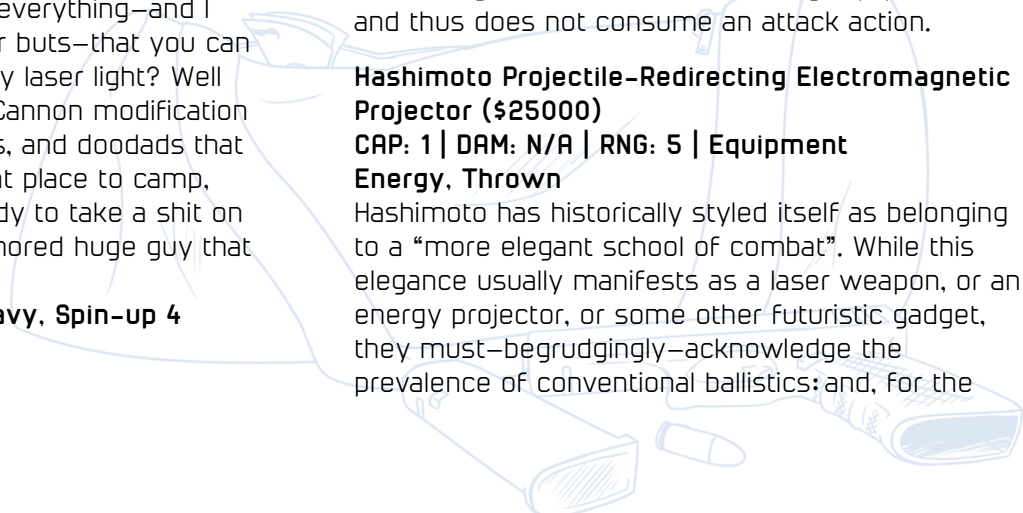

love of precision and refinement, they brought the PREP to market. This little beauty is like nothing else on the market, and it's damn devastating in the right hands. The PREP is a discus-shaped device, which projects a powerful electromagnetic field directly upwards, the polarity of which can be altered remotely. What this means is that if a metallic object—such as a bullet—passes through it, its trajectory will spontaneously change; in essence allowing you to curve a bullet. This is very useful.

Anyone with a weapon that has the Arrow, Warhead, or Bullet type may choose to attack the Hashimoto Projectile-Redirecting Electromagnetic Projector. If they do, they roll murder as normal; in the event that the shot is successful, they may then alter the trajectory of the attack any way they choose, so long as the target is within [X] spaces of the PREP, where X is equal to their weapon's range minus the amount of spaces the projectile has travelled this turn. Then, roll murder again at a -2 penalty; and if this is successful, the attack connects. Every additional PREP that the projectile passes through requires another roll, and inflicts another -1 penalty.

## Doodles: Gags and Graffiti

### Doodle In a Can (\$Special)

**RNG: N/A | IP: N/A | Equipment**

Ink is hard to come by, and paper even harder—and you can straight-up forget about getting talent in any kind of timely fashion. Fortunately, you can still use doodles—kind of. These simple one-use doodles come in cans, darts, balls, and more; and they use nanite-infused ink to deploy a pre-selected drawing on command. In effect, they're spells that you can throw like grenades.

Doodle in a Can has the stats of a single doodle of your choice, excluding the IP cost, which is instead 0. Canned Doodles cannot be sustained and cannot be purchased for doodles with an IP cost greater than 3. Doodle in a Can costs 1/10<sup>th</sup> of the original doodle.

**Disposable, Limited-Use 1, Idiot-Proof**

### Peel (\$500)

**RNG: 12 | IP: 1**

Ah, the Banana Peel: one of the simplest gags of all time, and it's been solid gold since the vaudeville era. All you gotta do is draw yourself a wavy lines and a stem, and you're off to the races. People

have been known to shout “Na’na pi-el” when doing this to try and sound cooler than they are.

If you successfully use Peel, your opponent must make an athletics roll at a -4 penalty. If they fail, you may move them two squares in any direction. If your target used a move action on their last turn, they may not make a counter roll. If they used two move actions on their last turn, they will lose one action on their next turn.

### Yank (\$500)

**RNG: 10 | IP: 1**

It's a lot easier to stop being shot if your enemies don't have guns. Easiest way to make that happen is to use a weapon magnet: it's a magnet with the word “WEAPON” written on it. It'll magnetize wood, plastic, steel, and whatever else is currently being used as a weapon—don't leave home without it!

When you activate Yank, designate a target within range. You may move their active weapon up to two squares in the direction of your choice. They may counter this effect with a successful grit roll.

### Barrier (\$1000)

**RNG: 3 | IP: 1**

The barrier is one of the most useful gags you can have: a simple line of ink placed between a target of your choice and the world around them. While it is ineffective against larger weapons and energy, it is able to turn away small arms fire for several seconds, which can be critical during a firefight.

When you activate barrier, designate an allied character within range—this may include yourself. Upon making a successful spellcasting roll, the target gains a **magical SPC** shield worth 5 points until the end of the turn. During your turn you may restore the shield to full strength for 1 IP and no action cost. You may only have 1 barrier active at a time.

### Line in the Sand (\$1000)

**RNG: 8 | IP: 3**

There's some lines that nobody, no matter how bad they are, will ever cross. Specifically, the big inky lines that have “DO NOT CROSS” signs sticking out. This gag is one such line, and it will hold fast against anyone.

When you use Line in the Sand, designate three adjacent squares on the map: they count as a solid wall for purposes of any and all movement, but as empty space for Line-of-Sight and Cover. During your turn, you may sustain the line for 1 IP and no roll or action cost.

### **Fake Wall (\$1000)**

**RNG: 8 | IP: 3**

As nice as it would be to just draw a real wall and stick it in the ground, ink and other materials only ever mesh so well. So instead you get this: a square, which doesn't have much behind it but can stand in place for a few seconds. It's a great thing to hide behind, and great to keep between you and the enemy. Unfortunately it doesn't do a gnat's toot for actually *stopping* them.

When you activate Fake Wall, designate three adjacent squares on the map: they now count as a solid wall for purposes of Line-of-Sight and Cover, but as empty space for movement. During your turn, you may sustain the wall for 1 IP and no action cost.

### **Lift (\$1500)**

**RNG: 10 | IP: 2**

Sometimes you really need someone to be a few feet above where they currently are now. That's why we have a collection of Lifting gags: feathers, burning spikes, scissorlifts, and jacks—all of which can be positioned underneath people you want to be either badly inconvenienced, or above where they are now. Ideal for getting enemies out of cover and allies into tall buildings.

After activating lift, designate a target within range. The target will be lifted one square into the air. This will eliminate any benefit they would get from cover, arrest further movement, and impose a -2 penalty to any rolls they make for the duration of the turn. At the beginning of your next turn, you may choose to sustain the lift for 2 IP and no extra roll, or double its effects for 3 IP and a roll at a -3 penalty.

### **Armor Strip (\$7500)**

**RNG: 10 | IP: X**

Do you hate people who are wearing body armor? So did whoever invented this suite of high-powered inktek. With nothing more delicate than a spike and a big cartoony hammer, this baby can absolutely *eat* ant suit of armor on the market. Given that it was designed specifically to avoid doing harm to living matter, this was probably meant for mining or cave-in rescue, and not actually for combat—but, ya know, fuck guys in armor.

Upon using armor strip, name how many IP you wish to spend to cast it. You lose that many IP, and the target loses that many points of their armor. Upon an unsuccessful cast, you lose half that many IP, rounding down.

### **Flash Step (\$7500)**

**RNG: N/A | IP: 2**

Teleportation is a prohibitively difficult thing for inktek: transporting any amount of deconstructed matter through the ink will completely ruin it. The closest thing people have come to teleportation through inktek is the Flash Step: topically-applied motion lines which can be used to enable rapid transportation over short distances.

On any turn where you use Flash Step, you may use your Artistry score in place of your athletics score for purposes of movement speed calculation on any move actions you take that turn, without making a roll. Any move action made using Flash Step does not require athletics rolls to traverse difficult terrain, and it allows you to invisibly move through enemy line of sight without requiring a stealth roll or triggering guards. However, flash steps can only be to tiles you can currently see, and you may not angle it around or through walls, windows, or doors, at any time. Flash Step does not confer any movement or additional actions, but does not itself cost an action.

### **Force Lock (\$7500)**

**RNG: 3 | IP: 2**

The annoying thing about B&E is that the places you really want to be are usually behind locked doors; and when your hacker is too drunk to slice, your techie is too dumb to pay attention, or your shotgunner is busy spanking it in the corner, your artist can save the day yet again. This doodle can be used to handily blow the hinges and lock off of nearly any door—so long as you don't mind a little noise...

Force Lock can be used to open a locked or electronically-locked door, but not a blast door of any variety. Doing so alerts all enemies on the map to your location.

### **Mass Peel (\$12000)**

**RNG: 8 | IP: 3**

If something is funny once, it's REALLY funny if it happens to a bunch of people at the same time! See: people shitting their pants.

...At least, we hope so. Otherwise this gag isn't really that great.

Mass Peel allows you to push every target in the blast radius as though you were using "**Peel**" against them.

**Blast 1**

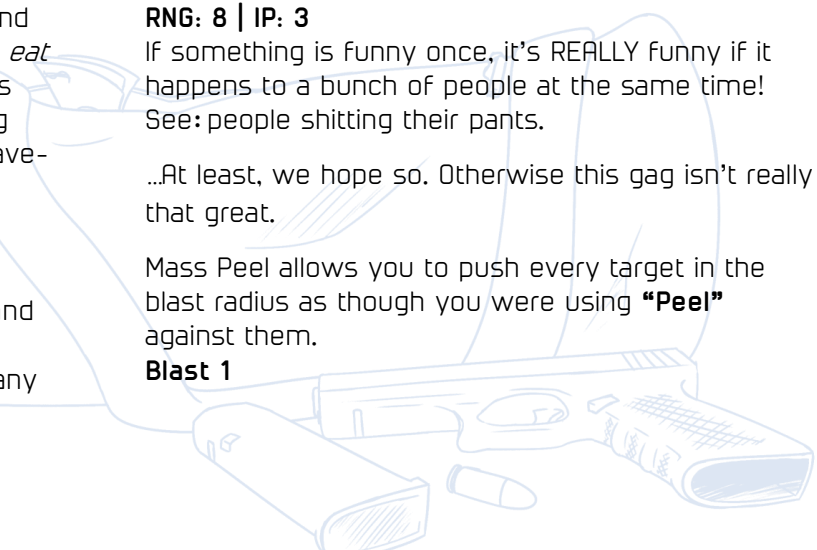



### **Spatial Compression (\$12000)**

**RNG: 12 | IP: 3**

Spatial Compression is a rarely-used doodle, perhaps unfairly. While it is not particularly difficult or draining, it is considered to be of little practical application. Rather than pushing targets in a direction, it pulls them towards a designated point in a radius. Spatial compression is, thusly, more of a spell meant for enabling your allies to inflict carnage, rather than doing it yourself. It pairs well with rocket launchers, flamethrowers, samurai, pianos, and heavy machinery.

Upon a successful artistry roll, every enemy within the blast zone will move 2 squares directly towards the center of the blast, losing an action and taking 1d2 damage if they impact anyone else. Enemies may attempt to resist the effects of Spatial compression with a Grit roll. If your targets used a move action on their last turn, they may not make a counter roll. If they used two move actions on their last turn, they will additionally lose one action on their next turn.

**Blast 3**

### **Prescience (\$8500)**

**RNG: 3 | IP: 4**

This particular doodle takes a whole lot of explanation to really understand: but basically what you need to know is that this nifty piece of tech will help you easily and near-instantly memorize the working theory and application behind a wide variety of complex and esoteric fields.

When you use Prescience, you or a targeted character instantly gain 1dX points in the specialty of your choice, where X is your spellcasting score: this number can be added to extant specialties, but cannot be made to exceed the normal limit of 10 points in a skill. This effect persists indefinitely, though you may only have one instance of Prescience active at a given time. You may additionally use Prescience a single time before the mission begins, at no IP cost.

### **Terrifying Suggestion (\$10000)**

**RNG: 16 | IP: 1**

"I am now going to assault your mind with subliminal messages!" There's more to frightening people than showing them something scary—you have to make them wonder if they ever really saw it in the first place. This doodle whispers something horrible in your enemy's ear, and then vanishes without a trace. Happy Haunting!

**Fear 3/3**

### **Obfuscation (\$9500)**

**RNG: 3 | IP: 1**

The Obfuscation is a favorite of medics, infiltrators, and fugitives throughout local space. Obfuscation is not true invisibility, but it does have a similar effect: specifically, so long as the target is within a group, it causes anyone who looks at it to mentally "Gloss over" them, as though they were a zebra in a herd, or a homeless person.

Obfuscation makes one ally untargetable by enemies, so long as they are within two squares of at least two other allies. If they ever fall out of this formation, the effects of Obfuscation will dissipate. The effects of obfuscation will be nullified if the target attacks an enemy. Obfuscation does not grant a sneak attack bonus.

### **Combat Focusing (\$10000)**

**RNG: 8 | IP: 2**

It's the opposite of fear. Nuff said.

The Combat Focusing spells applies a +3 bonus all rolls the target makes. This buff degrades at the beginning of your next turn, it does not increase with repeated applications.

### **Horrible Image (\$12500)**

**RNG: 10 | IP: 3**

What awful, profane, unnatural thing is written on this paper? Why does it make people clutch at their eyes and scream "NO, NO, IT'S AWFUL"? How could you be cruel enough to show it to someone?! All questions nobody really cares about in the long run.

**Cone 3, Fear 6/6**

### **Chain Lightning (\$15000)**

**RNG: 12 | IP: 3**

Just insert some reference to the lightning bolt meme here. And then if you found that amusing, go take a few moments to rethink everything you've ever done.

After Chain Lightning's initial strike, check to see if there are any augmented or robotic enemies within 5 spaces of the initial target. The effects of Chain Lightning apply to them as well. Chain Lightning can transfer any number of times, but can only apply once to any given target.

**EMP 1**

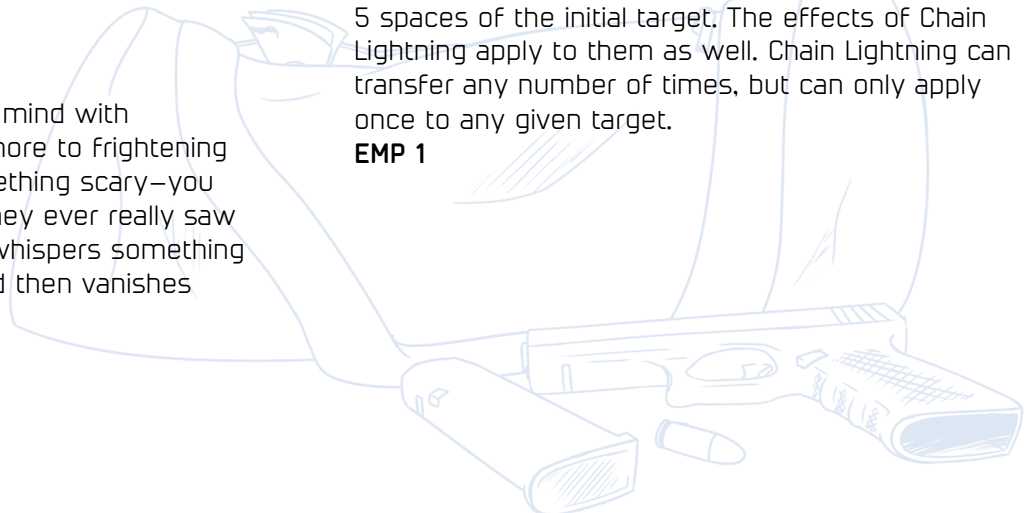

## Radial Barrier (\$25000)

**RNG: 0 | IP: 5**

There's a large number of commercially-available doodles that are basically "Just like another one, only a whole bunch". The Radial Barrier is one such doodle, and it functions identically to the Barrier, if it were employed several times rapidly. It is, simply, the Barrier's more evolved form: a series of several inks manipulated via a standard fumbler, the Radial Barrier is capable of rapidly drawing and erasing shields almost as soon as people pass within the operational range.

When you cast Radial Barrier, everything that stands or enters its radius before your next turn gains 5 points of magical SPC shield. Any shields conferred this way will not degrade after the end of the caster's turn, but will expire IMMEDIATELY if the recipient exits the spell's radius at any time for any reason. At the beginning of your next turn you may choose to re-cast the spell again for 3 magic points, with no additional rolls or action cost.

**Blast 5**

## ArcBright Systems Ethereal Aegis (\$25000)

**RNG: 0 | IP: X**

While developments in applied ink are made in leaps and bounds, the possibilities of such is only *slightly* more interesting than what can be done with them already! For example, the patented Ethereal Aegis—one of the few doodles to have proprietary protection—is an absolute marvel. It is a series of ball-bearings which have been engraved with microscopic doodles. These arrange themselves in a net-like pattern, and begin projecting a magnetic field of unprecedented magnitude—one strong enough to not only dampen the impact of bullets, but turn them away entirely.

When you cast the ArcBright Systems Ethereal Aegis, do not expend any IP. Instead, whenever an ally within the radius would be hit by an attack of any kind, ignore the attack and subtract an amount of IP depending on the attack's listed type. Subtract 2 for Warhead-type and Chemical-type weapons, 1 for Bullet-type weapons, and none for throwing or energy-type weapons. Attacks with none of these types are not blocked, and weapons with multiple types use the highest cost. Each expenditure of IP made this way is treated as an individual doodle, and is subject to effects which would increase or decrease the cost of a doodle. For every 5 instances blocked this way in a single turn, the IP cost for each kind of projectile increases by 1. So long as you are casting Ethereal Aegis, you may not

use or maintain other doodles of any kind. Ethereal Aegis may be disabled at any point with no action, even if it is not your turn.

**Blast 5, Spin-up 1**

## Wallspike (\$25000)

**MP: 5 | RNG: 15**

When you're facing a dug-in opponent, the value of a good tekkie cannot be overstated—and as long as yours can do a Wallspike, he's goddamn fantastic. After using a simple Inkpulse to determine the location of targets hiding behind cover, the doodle violently excites the molecules near them and—through a modified transmogrification tek—causes them to grow sharp porcupine-like spikes that do truly unpleasant things to anyone within their reach.

When Wallspike fires, every enemy in the blast area (ignoring cover), currently adjacent to a cover object will take 5 damage. They will take 5 damage each turn until they move out of cover. Wallspike may only affect a given target once per turn, no matter how many instances would affect them.

**Spin-up 2, Blast 10**

Amnesia (\$25000)

**MP: 5 | RNG: 5**

Here come the men in black.

If you cast Amnesia on someone, they will instantly forget the events of the last 5 minutes; unfortunately, this only applies to targets that have not yet engaged in combat. Handle with care.

## Transmogrify (\$25000)

**MP: 4 | RNG: 8**

Have you ever wanted to pull a rabbit out of a hat? Well, this won't let you do that, but it DOES let you create a rabbit for a few seconds. This simple-to-explain tool is still the greatest trick a tekkie can perform: This is because, with a few clever ink swirls, this spell instantly transfigures the target into a harmless bunny rabbit! Unfortunately for all of you who would seek to use this to incapacitate and destroy your enemies, it turns out harmless bunny rabbits are so freakishly adorable that no thinking creature can bear to harm them.

When someone is hit by Transmogrify, they instantly turn into a rabbit for 1d3 turns. While in this state they cannot attack or be attacked, targeted by anything other than transmogrify, or damaged by any attack; and their movement speed is halved. Repeated instances of transmogrify cast on a transmogrified target do not stack; but the length of the effect is re-rolled each time.

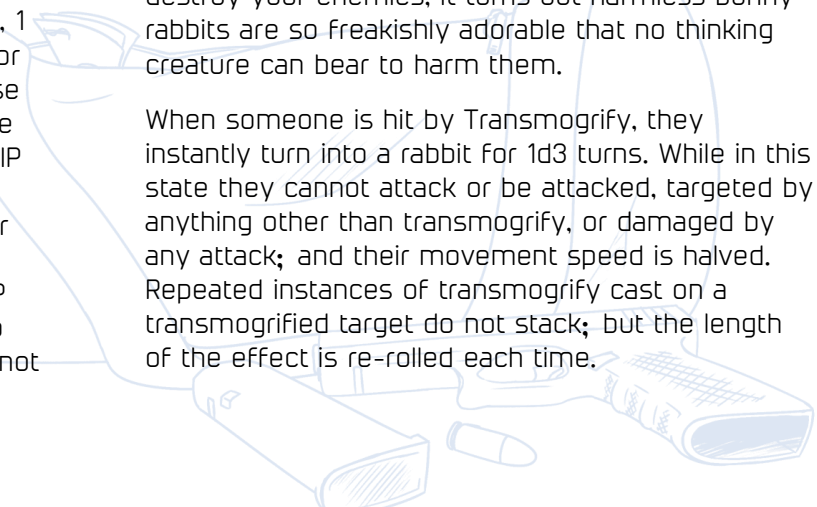

## **Hellmouth (\$30000)**

**MP: 5 | RNG: 20**

Hell and its sub-realms are a complicated place to be. The Satans are meticulous and have very particular tastes; and the numerous sub-Satans and Abbadons and Buzreals and Carnagods are so thoroughly entrapped in their superior's never-ending bureaucratic stalemates that it's unsurprising that they have some fire and rage to vent. The Hellmouth is a very destructive little doodle, which opens a one-way door from Hell to wherever you are pointing it at. Whatever emerges will be unpleasant.

The spin-up time of Hellmouth is reduced by 2 actions for every ally who uses it at the same time, so long as they are within 5 squares of each other.

**Burn 10, Blast 4, Contaminant 3, Spin-up 6**

## **Haste (\$25000)**

**RNG: 8 | IP: 3**

The nature of time as a manipulable force has proven a constant fascination to scientists. There is enough evidence to suggest that time itself can be altered or passed through by inks of sufficient complexity. Haste is a result of an early foray into that field: while it does not actually alter the flow of time, it does have an effect which might be confused for such: motion lines, affixed to the extremities, which allow the wearer to move with incredible speed, without losing any control over their movements. While this was originally intended to allow its users to walk short distances into the future, the vast number of fatalities that occurred dissuaded further inquiry into the subject for some time.

Target gains additional movement action for one turn. This action cannot be used to attack, cast a spell, or use or interact with an object, item, or piece of equipment. This action must be used only for regular movement or tumbling. Only one instance of haste may be cast on any given target at any given time.

## **Inkwell (\$2500)**

### **Equipment**

It is understood among tekkies that there is only a certain amount of ink which can be channeled through a body over a given period before they begin to experience adverse physical effects: things such as spotty vision, headaches, and nosebleeds are unfortunately common, and often serve as a prelude to things like widespread swelling and hemorrhaging! This is the result of a combination of stress and dehydration—and can therefore be

dramatically reduced by a simple intravenous injection. This potent drug cocktail can extend any tekkie's longevity by a tremendous amount—so long as they don't mind the track marks.

When you use Inkwell, lose 1 health; your IP is then replenished to 15. This damage cannot be reduced by any means.

**Limited-use: 1, Disposable**

## **Arcbright Industries Kineticka Staff (\$12500)**

**CAP: INF | DAM: 2 | RNG: 1 | Long | Melee**

In fantasy and folklore, wizards were commonly depicted as relying on wands, staves, or other magical baubles to focus and amplify their power. Thus, while any old instrument would do, staves are the popular fashion statement among tekkies today: The Kineticka in particular. While it is no more complex than a retractable baton with an inset gag, they provide valuable personal defense which simultaneously increases their drawing power. It acts as a "battery" of sorts—allowing its wielder to perform feats of ink that would normally be taxing.

While you have the Arcbright Industries Kineticka Staff equipped, any doodle that would move an enemy may—if you so choose—move them one square further than normal. Additionally, while it is equipped, you may spend [X] IP, where X is the number of enemies currently within 5 squares of you, and move each of them directly away from you until they are 8 squares away.

**Simple**

## **ArcBright Casting Cards (\$15000)**

**CAP: 4 | DAM: N/A | RNG: 10 | Short | Doohickey**

The Casting Cards are a revolutionary spellcasting system designed for use in the home. This simple set of cards, no larger than the average bicycle card, can be imprinted with a wide variety of tek, and thereafter hurled a moderate distance—allowing you to activate them from the point where the card falls. Now, let's get this out of the way: this is not your duel disc, gambit cards, library, graveyard, or pokedex. Referring to the Arcbright Casting Cards by any of these names may result in immediate and severe consequences.

When you bring the ArcBright Casting Cards with you on a job, designate up to four doodles currently in your inventory. Whenever you fire the ArcBright Casting Cards, you may use one of those doodles as though its point of origin was the Casting Cards' target. Doing so imposes a surcharge of 1 IP.

**Idiot-Proof, Simple, Slowloader 2**

## Stayin Alive: Armor For Your Body

### Atlas Outfitting Heavy Impact Jacket (\$10000)

**ARM: 7 | Mesh | Torso**

The Atlas Outfitting Heavy Impact Jacket was conceived as a straight improvement upon their already-successful vanilla personal protection vest. In this respect, it succeeded magnificently—with the simple addition of shoulder pads, sleeves, and a neck brace, protection was dramatically increased without impeding mobility. While the HIJ doesn't have quite the resistance to damage that other jackets do, it is favored by many operators regardless.

### Atlas Outfitting Juggernaut Jacket (\$20000)

**ARM: 8 | Ceramic | Torso**

When a great big padded sports coat isn't enough for you, there's always the Atlas Outfitting Juggernaut. It's exactly what it sounds like: a Heavy Impact Jacket that's had some of the pads removed, and instead replaced them with hard ceramic braces. This works to create a jacket that is not only durable and resistant to most small arms, but is comparatively lightweight.

Wearing the Atlas Outfitting Juggernaut Jacket reduces your movement per move action by 1/3 rounding down.

### Meditational Tunic (\$500)

**ARM: 1 | Mesh | Torso**

This is a simplistic meditational tunic of the sort worn by many monks. While it provides a paltry amount of armor, it's been fashioned in such a way to enhance the wearer's "Chi" or whatever the Hell.

If you wear the Meditational Tunic for the entirety of a job, you will gain 2 power bursts instead of 1 at the end.

### CorpTechs Hephaestus Exoskeleton (\$22000)

**ARM: 5 | SHD: 3 | Ceramic | Torso**

While this simple exoskeleton is bulky, clunky, difficult to maintain, and impossible to conceal, it has its uses in the operator's world: because it was primarily intended for labor use, it doesn't necessarily raise red flags, and is fairly inconspicuous. This is the preferred power armor for most self-made men, for obvious reasons.

**Invulnerable 2, Mighty 2, Burdensome**

### Atlas Outfitting Speed-Oriented Combat Kicking Suit (\$12000)

**Boots**

While Atlas Outfitting is most famous for its massive hulking suits of armor, they are not too set in their ways to innovate. They have leveraged modern technology to capitalize on the needs of today, to great effect. One of their most notable "new" products is the Speed Oriented Combat Kicking Suit—a quartet of microfiber-augmented tactical gloves, which are inlaid with a number of strategically-placed Mesh patches designed to dampen impact from outside forces while allowing you full maneuverability in a combat situation. This allows you to dramatically negate the effects of enemy close-range weapon impacts, and thus increase your survivability in close quarters.

While wearing the Atlas Outfitting Speed-Oriented Combat Kicking Suit, you may reduce the effect of enemy clash success results by 1; and you may reduce any damage done to you in a clash by one half rounding up, so long as the weapon which inflicted it did not pierce Ceramic or Plasteel.

**Undetectable**

### Oracle Inc. Outflow Improvement Vest (\$12000)

**ARM: 2 | Mesh | Torso**

While the marriage between ink and meat is a tumultuous one, it is one that is kept afloat by the frequent use of highly expensive and moderately unsafe relationship aids: enter the Oracle Incorporated Outflow Improvement vest, which uses a combination of servo-driven respiratory regulators and a network of dermally-applied convectionary heating elements to optimize a scribbler's outflow potential—so they can to draw more, for less!

While wearing the Oracle Incorporated Outflow Improvement Vest, all doodles cost one less IP to cast and sustain.

### Oracle Inc. Basic Cognitive Enhancer (\$15000)

**Head**

It's, like, a headband, and you put it on, and it massages your temples so you can do the thing better, don't ask me I ain't a fuckin wizard.

While wearing the Oracle Incorporated Basic Cognitive Enhancer, you may maintain one currently-cast scribble at no IP cost. When you scribble while wearing the Oracle Inc. Basic Cognitive Enhancer, you may use your remaining action that turn to use one extra doodles with an IP cost of equal or lesser value to the prior doodle. This doodle does not expend IP upon casting.

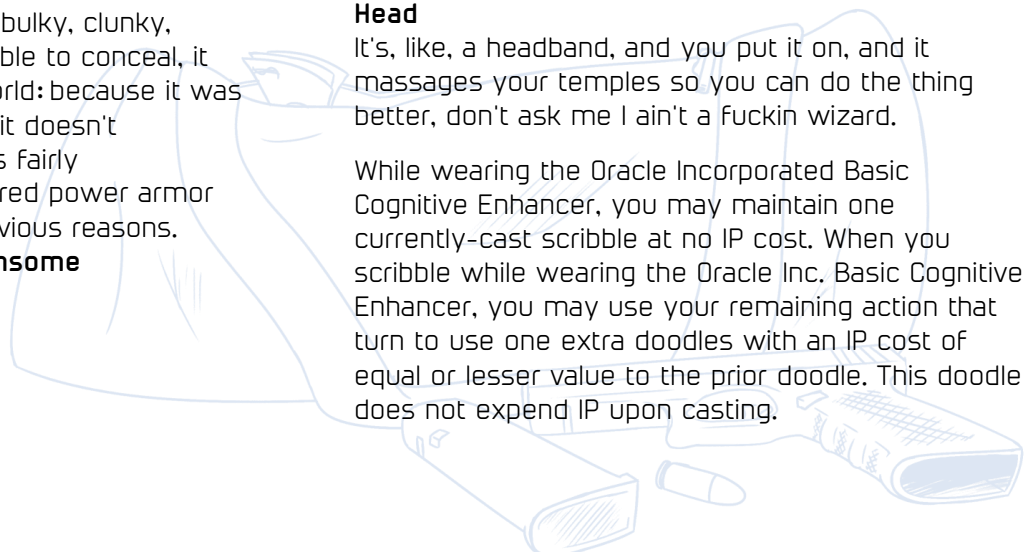

### **Divinity Systems MDA Suit (\$25000)**

#### **SPC: 5 | Torso**

Ever since spy movies have been a thing, the armor industry's wet dream has always been the bulletproof suit. It's the logical conclusion of armor, after all: lightweight, form-fitting, comfortable, classy, and above all else functional. So when Divinity Systems revealed their Multipurpose Deflector Apparatus to the public, we all knew we were living in the future. While the MDA Suit has the requisite Mesh weave that all protective suits have, it boasts a unique advantage: a web of nanobots roughly 1.5 millimeters thick, which are capable of detecting impacts and hardening to resist them with a .000002 second reaction time. However, activation rapidly causes the nano-network to expend itself from the sheer friction it exerted upon it by the fabric. This means that the MDA suit grants its wearer nigh-complete, albeit very short-limited, invulnerability upon activation.

So long as the Divinity Systems MDA Suit's Special Barrier remains active, any attacks that would damage it may only deal a maximum of 1 damage.

### **Apogee Satana Anole Necktie (\$5000)**

#### **Torso**

The tail of a Anole lizard is a clever thing: it can be detached from the rest of the body, and will grow back in time. In the wild, this allows lizards to escape from predators that attempt to catch them by their tails; and the mad geniuses at ASFP saw it as nothing less than a work of genius. The Anole Necktie is a tie, collar, choker, or other obviously-worn fashion accessory around the neck, which is designed to break away if pulled. This means that aside from looking stylish, it encourages opponents to target your seeming vulnerability—which leaves them open to counter-attack when its true nature becomes plain.

While wearing the Apogee Satana Anole Necktie, the first enemy clash success roll made against you that scores higher than a 2 becomes a 1 instead. This may only occur once per job. You may wear the Anole Necktie with any other piece torso-slot item.

### **APSF Operator's Helm (\$12500)**

#### **ARM: 1 | Head**

As a reasonably priced alternative to a military combat helmet, the ASPF Ophelm protects and assists you in a way few others can.

While wearing the ASPF Operator's Helm, once per mission you may treat a critical hit made against

you as a normal hit instead.

#### **Dead Giveaway**

### **Shieldscale Industries Hexplate (\$30000)**

#### **ARM: 7 | Ceramic | Torso**

Bullets kill, and ink kills too. Thus, the Hexplate was designed: something that can take the wind out of both. Indispensable for graffiti-hunters.

While wearing the Shieldscale Industries Hexplate armor, spells which would affect you do not. This does not affect doodles which are not cast on your person.

#### **Dead Giveaway**

### **Shieldscale Industries Blast Shell (\$12500)**

#### **SHD 6 | Head**

Every major arms company in the worlds has taken a crack at energy shielding at least once. There have long been dollar signs over the idea of a shield that can withstand sustained fire without overheating or exploding. The Blast Shell is a simple helmet-mounted shield generator, which, when terminally disrupted, discharges a specially-made energy core mounted on the sides. It's basically a bomb helmet. Handle with care.

When the Blast Shell's shielding is depleted, it does damage equal to 1/2 of the attack that depleted it, rounding up, to everyone within 3 squares, except the user.

#### **Dead Giveaway**

### **Atlas Outfitting GUT Tactical Vest (\$7500)**

#### **ARM: 5 | Mesh | Torso**

While the GUT tactical vest has long enjoyed a devoted following among SWAT officers and airsoft enthusiasts. Though its ballistic protection is relatively limited, it compensates for this with a vast array of webbings, pouches, and pockets. The GUT is ergonomically and modularly designed, to allow its wearer to store extra bandoliers, grenades, or belts; meaning that while it is unsuitable for sustaining fire, it is indispensable for heavy gunners, demolitionists, and other supportive types.

When you equip the Atlas Outfitting GUT tactical vest, designate any three equipment items in your inventory that have the "Limited Use" trait, before the mission starts. So long as you are wearing the GUT tactical vest, you may use those items one additional time.

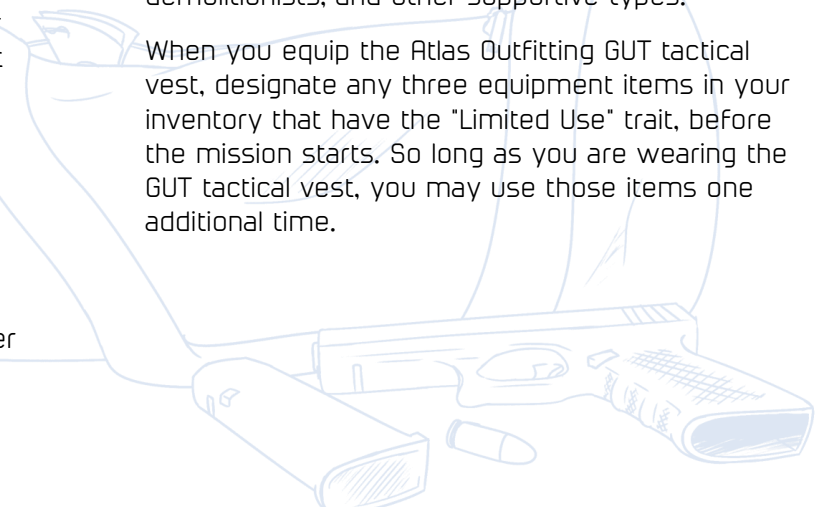

### Atlas Outfitting Ulysses Personal Protection Suit (\$75000)

ARM: 10 | Plasteel | Torso

The absolute end-all and be-all of low-tech armor, the Ulysses Personal protection suit has everything the original did, except the trick heel: a custom-fitted mesh weave bodyglove augmented with plasteel plates means that this armor is flexible, comfortable and, most importantly, absolutely HAM. Intended for use by commandos and riot cops, a suit like this is a worthy prize for any operator. However, while Plasteel is comparatively lightweight for its density, it's *still* steel—and you're going to feel it.

While wearing the Atlas Outfitting Ulysses Personal Protection Suit, and your maximum movement per move action is decreased by 1/3 rounding down.

**Dead Giveaway, Burdensome**

### Div/Atlas Achilles Protection Suit (\$150000)

ARM: 10 | Plasteel | Torso

When plasteel was no longer sufficient protection for soldiers of the modern day, Atlas Outfitting knew they would need a new edge in the arms race. When the power of information was no longer enough to prepare for every eventuality, Divinity Systems realized that they would have to master the physical as well as the digital. Thus, during the closing years of the First Onyx Age, a tremendous partnership was formed, and the world of personal protection gained a new bleeding edge. The Achilles Personal Protection Apparatus is a series of plasteel plates layered over a carbon-fiber mail, all of which is manipulated by a neurally-controlled endoskeleton. The end result is a suit of armor that is beautiful and durable as they are rare and expensive: usually reserved only for high-value bodyguards and Apex commanders, the Achilles suit has remained unchanged and in steady production for almost twenty years.

**Uplink (I) 2, Dead Giveaway**

### Divinity Systems Hargreave Infiltration Suit (\$150000)

ARM: 8 | Plasteel | Torso

While the Hargreave Cybernetics Corporation was acquired in its entirety by Divinity Systems, the company name is still used on a number of legacy products. This lightly-armored plasteel suit boasts easily-worn form-fitting musculature enhancers designed to aid in quietly subduing targets, as well as a terrain-emulating active camo system that remains relevant even forty years later. It is not, by any means, the finest stealth suit available—but it's damn good.

While you are wearing the Hargreave infiltration suit, you are invisible to the naked eye and cameras alike so long as you are standing still, and your stealth skill is level 0 or higher.

**Mighty 2, Uplink (I) 2, Dead Giveaway**

### Divinity/Atlas Metis-Class Computational Enhancement Suit (\$150000)

ARM: 8 | Plasteel | Torso

As part of the Divinity/Atlas combat modernization initiative, a number of efforts were made to reduce the size of rapid-use information warfare apparatuses; however, they could only shrink computer screens by so much before actual microscopes were needed to use them. Fortunately, they came upon the idea of integrating a miniaturized computer into the spinal area of the suit—which, while mildly uncomfortable to most wearers, is perfectly capable of compensating for pilot error in most digital offensives.

While you are wearing the Divinity/Atlas Metis-Class Computational Enhancement suit, you may increase the results of successful hacking clashes by 1. You also gain 2 extra processing power for...whatever.

**Uplink (I) 2, Dead Giveaway**

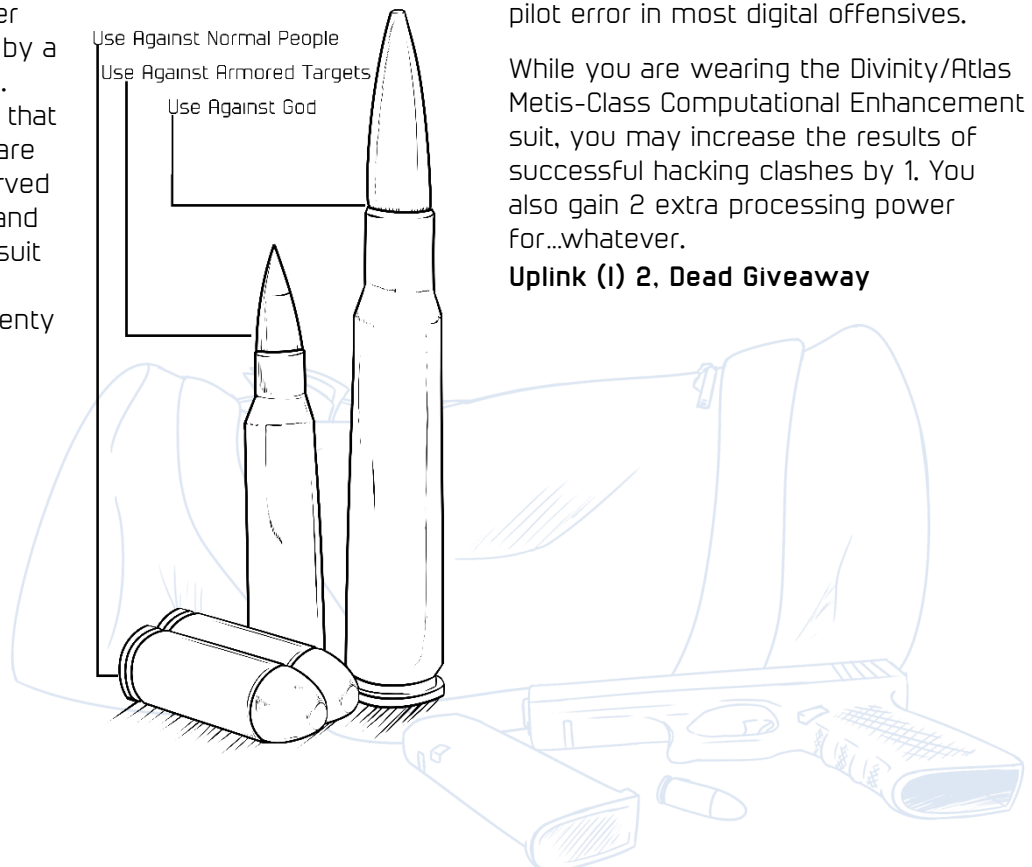

## Survivallist Gas Mask (\$5000)

### Head

When you're on the beat, a simple balaclava or motorcycle helmet is everything you need to get through the night's work. However, once in a blue moon, you're going to have to specialize. While gas masks have been made by numerable companies throughout the years, they all serve the same purpose: they filter the air you breathe of chemicals, gasses, and airborne radiation. While these little leather beauties don't have the armor functionality of combat helmets, it's always a good idea to keep one in your pack—just in case; and best of all, they can be acquired cheaply at Survivallist.

While wearing a gas mask, you are immune to the Poison trait.

## Survivallist Radiation Shield (\$2500)

### SHD: 1 | Equipment

This rad-shield is one of Survivallist's homegrown beauties, which means it's dirt-cheap, it does exactly one thing, and it doesn't do it very well. Mounted on the waist, this fancy little belt-buckle can keep your eyeballs from falling out due to radiation, even if it's from concentrated weapons! But, uh, this thing really was made on the cheap, so don't expect it to block bullets at all. Or...anything except radiation, actually.

## Functional Fashion: Stuff you Wear that Isn't Body Armor

### CorpTechs Cargo Pack (\$500)

#### Storage

Easier to carry than a duffel bag, the Cargo Backpack is the preferred storage method of tinkerers, distance hikers, soccer moms, and teenage runaways everywhere. While it doesn't have as much raw space as a duffel bag, the Cargo Pack makes use of a number of partitioned storage to allow you to organize and carry a large amount of equipment with minimal effort.

The CorpTechs Cargo Pack may be used to hold up to eight items with the **Equipment** size; up to four items with the **Helmet, Pants, Boots, or Armor** sizes; or up to twenty-five thousand hands' worth in loot items. While in the Cargo Pack, all of these items are considered hidden, but can still be revealed by metal detectors. It cannot carry anything with the small, short, or long sizes.

### Olympus Sporting Goods Duffel Bag (\$500)

#### Storage

A jet-black sports bag that hangs over your shoulder. It's used to carry things: carry guns into a crowded area, carry money out of a bank, or even carry more bags! An OSGDB can carry two items with the **Long, Short, or Compact** sizes; up to four items with the **Helmet, Pants, Boots, or Armor** sizes; or up to twenty-five thousand hands' worth in loot items. While in the OSGDB, all of these items are hidden, but do not gain undetectable. It cannot be used to carry items with the **equipment** size.

Removing an item from a duffel bag, or putting an item into one, takes 2 actions.

### Balaclava (\$500)

#### Head

The labels are peeled off, the tags are snipped, the glue's been dissolved, and it's been disinfected and washed three times. This is a quintessential piece of criminal gear: not only does it keep you warm, it hides your face from prying eyes. While you're wearing one of these bad boys, cameras and witnesses can't get a good look at your face; but you stick out to just about everyone on earth as someone who is quite obviously a criminal.

While wearing a balaclava, you will no longer be automatically incarcerated for committing crimes while your infamy is 15 or greater.

### Olympus Motorcycle Helmet (\$1500)

#### ARM: 0 | Head

The only thing better than masks is helmets: because while masks might conceal your identity, helmets do that *and* provide a certain measure of protection—and those can easily mean the difference between life and death. This simple Motorcycle helmet, brought to you by Olympus sporting goods, protects both your identity and your cranium. Once per game while wearing the Olympus Motorcycle helmet, you may treat one critical hit made against you by another character as a normal hit instead.

### Cat Ears (\$500)

#### ARM: 0 | Head

This set of styrofoam cat ears looks absolutely fucking kawaii. And, by simply concealing a directional microphone array within them, it is possible to hear sounds from further away while wearing these.

The Cat Ears gives +2 to the wearer's earshot radius, and +5 Moe to anyone wearing them.

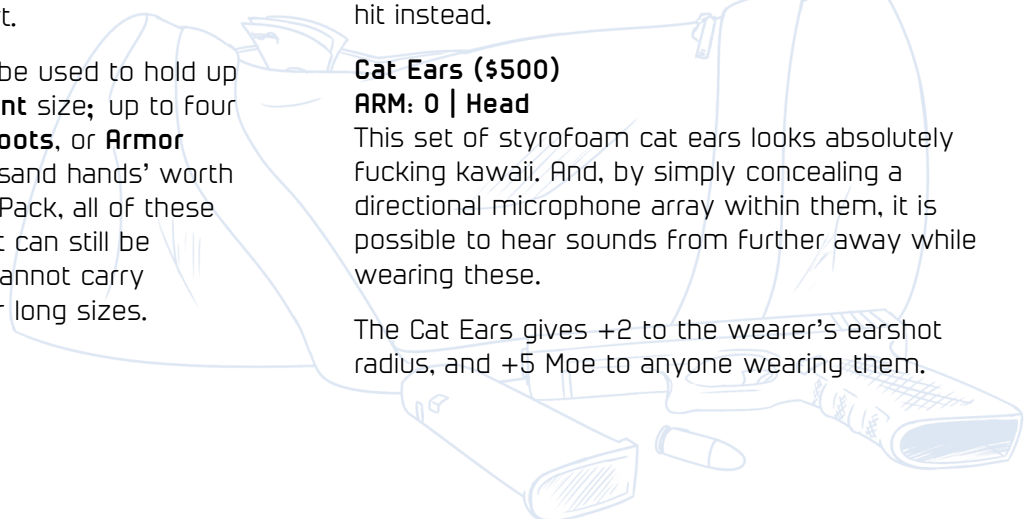

### Club Lucius Special: Duster Coat (\$500)

**ARM: 0 | Torso**

The better part of secrecy is done in plain sight. Case in point, the duster coat: not only does it make you look like a total badass, it allows you to stash small arms under it without raising attention. That might not sound like much good on direct combat ops, and it isn't; but when you're working in police territory, one of these can save you a whole lotta trouble.

The Club Lucius Duster coat allows you to stow short and compact weapons underneath it, which hides them from crowds and other passing creatures. It may be worn in conjunction with any piece of armor with an armor value of 5 or less.

### Blessed Medallion (\$20000)

**ARM: 0 | Head**

This is a cheap copper medallion inscribed with various symbols. These things can be bought at just about any kitsch store at the world, for outrageous prices. They don't do a damn thing, and their only significance is as an overpriced trinket, or else a conversation piece. Probably not worth it.

While wearing the Blessed Medallion, whenever you make a roll, you may spend a power burst to add your nonsense level to the value of whatever skill you are currently attempting to use, in addition to removing a single penalty as normal. This bonus expires once the roll is made, regardless of its success. You may do this only so long as the targeted skill's value is 0 or greater—you may not use a burst to enhance a skill with a value of -1. The Blessed Medallion may be worn in addition to any other item.

### Club Lucius Special: Foil-lined Duster Coat (\$1500)

**ARM: 0 | Torso**

Sometimes, the devil is in the details. For the Operator who walks like a gentleman and fights like a fiend, The Club Lucius Foil-Lined Duster Coat is the end-all and be all of concealment: not only does it shoo away prying eyes, its expansive tinfoil lining helps it beat metal detectors and EM scanners of all breeds. Any amateur can settle for a duster—but you're not an amateur, are you?

The Club Lucius Foil Duster Coat functions like the original, and confers the "undetectable" trait to any weapon in your inventory which you are not currently using.

### CorpTechs QuickDraw Weapon Holster (\$2000) Storage

Picture this, if you will. There you are, walking down the dusty alleyways of Dodge, when suddenly BAM! A bunch of no-good characters jump you from out of the shadows, with a no-good look in their eye! You reach for your trusty revolver, only to realize it's in your duffel bag! In your haste to open it, you are mobbed, stabbed to death, and cannibalized. Oh, the tragedy of it—if only you'd been able to reach your weapon!

And now you know why people buy holsters.

The CorpTechs QuickDraw Weapon Holster allows you to carry one additional weapon of any size on your person. Removing the weapon from your holster does not have an action cost.

### Softened Tabi (\$25000)

**Boots**

These softened boots muffle your footfalls dramatically, making it significantly harder for enemies to hear you. While wearing the softened tabi, you may reroll failed stealth rolls for the hearing sense.

### Densetsu Designs Laong Shadow Glaive (\$8500)

**CAP: INF | DAM: 3 | RNG: 1 | Head**

Ah, yes: the weapon-hat. A staple of martial arts and super-spy movies for as long as any of those things have existed, the weapon-hat always serves the same function: it's a hat, that turns into a deadly weapon. Within the confines of fiction, they have taken the form of boomerangs, buzzsaws, cannons, and more; but they were never a reality until this weapon hit the market. Despite being the fulfillment of a fantasy long-held by all kinds of weirdos, the Laong Shadow is sadly underwhelming in real life: at the touch of a button, one half of it sprouts a blade, which—while perfectly sharp and capable of cutting—sadly lacks much in the way of pierce potential or flashiness; thus relegating it to the duty of holdout weapon. Maybe someday our wish will come true.

**Undetectable, Pierce: Mesh**

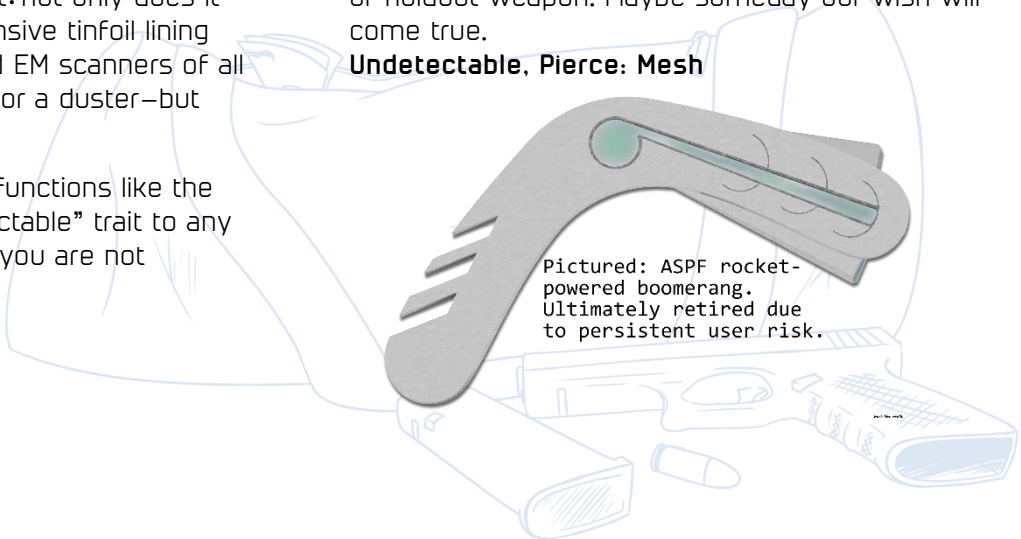

Pictured: ASPF rocket-powered boomerang. Ultimately retired due to persistent user risk.



## **Olympus Sporting Goods Thermal Glasses (\$10000) Head**

Military operators have used thermal goggles for centuries to see through smoke, snow, and other vision-obscuring eye-bothering things. But now, thanks to Olympus Sporting Goods, you no longer have to wear stupid goggles when you go out skiing, trekking, or whatever else you get up to! With a simple touch of a button, these stylish shades allow you to see in fancy-dancy thermal vision—so get out there, and see the world!

While you have the Olympus Sporting Goods Thermal Glasses equipped, you may ignore the effects of smokescreens, and your sight sense increases by 2 squares.

## **The Other Kind of Hardware: Tools, Wires, and All That Jazz.**

### **Ballistic Armor Repair Kit (\$7500) Equipment**

As useful as ballistic armor is, it has one teeny-tiny drawback: after it gets shot to ribbons, it stops being useful. But all you lovers of bloodshed need not worry, because there *is* another way, and that way is through the path of glue, duct tape, and wire! With a little ingenuity and some bric-a-brac, it's possible to mostly-repair all but the most technologically advanced suits of armor, to help the guy inside them live another hour!

Using the Ballistic Armor Repair Kit requires two actions, and it can be used on yourself or on any adjacent ally of your choosing, so long as their maximum armor is greater than 1, and their currently equipped armor does not have the **Uplink** trait. If you do so, roll hardware; and upon a successful roll, restore half their armor rounding up. This cannot be used to increase a target's armor past their normal maximum.

**Limited Use: 4, Disposable**

### **Utiliton Multi-tool White Mk. VI (\$2000) Equipment**

It's been around for over a hundred years, and it's STILL the way of the future. Since 2202, the CorpTechs Utiliton has been providing the gold standard of quality and ease, for thousands of workers nationwide. Just clip it onto your wrist, select from one of our six ergonomically-designed tools, and get ready to make history.

The Utiliton Multi-tool White comes equipped with a pair of wire cutters, an electric screwdriver, a small saw, a can opener, a bottle opener, a USB stick, and a magnifying glass. This allows you to cut through chain link fences, store data you encounter on computers, and probably some other stuff too.

### **Nano-Circuit Reconstruction Kit (\$10000) Equipment**

The nice thing about augments is that they're easy to maintain: take some nu-poz every so often, and some nano-circuit repair paste whenever something breaks. Circuit reconstruction paste—is standard issue in hospitals, police stations, and trauma kits around the country, most often in syringe form. As an operator, you will most likely encounter some variety of weaponized EMP at some point during your career; therefore it is of the utmost importance to your gang.

You may use a nano-circuit reconstruction kit on yourself, or an adjacent ally who has lost use of one or more augments. If you do, roll hardware. If this is successful, a single augment of the target's choosing augment resumes full functionality.

**Limited-Use: 5**

### **CSC Electronic Re-Programmer (\$10000) Equipment**

The CyberSects ERP was initially devised as a way to allow homeowners to remotely control their household functions from a single remote device. It succeeded, more or less; but it took about a week before someone realized that the ERP could be used for another, more nefarious purpose. With a simple application of wire crimpers and some creative tying, the ERP can be affixed to most first-world fuseboxes; and, so long as it is slaved to a wireless device within a hundred meters or so, its owner can manually activate (or ruin) the functions within.

If the owner of a CSC ERP affixes it to a fusebox, they can remotely perform the fusebox's functions at their leisure. Affixing and operating the ERP requires a hardware roll each time it is done.



## **CSC Penetron (\$15000)**

### **Equipment**

"Blast doors. Fuck 'em." That's the line of thought that lead to the creation of the CSC Penetron, a man-portable thermal drill with enough firepower to melt through an industrial-grade blast door in mere minutes. The application is simple: just carry it to a blast door, stick the suction-cuppy bits on it, and hit "GO".

The CSC Penetron can burn through blast doors in a number of turns equal to 25 minus 2 times the operator's hardware skill.

### **Idiot-Proof**

## **Olympus Skytouch Grapnel Line (\$10000)**

### **Equipment**

Rock climbing is hard, and dangerous, and relatively unrewarding. Fortunately for all you casual climbers out there, Olympus has a solution: The Skytouch Grapnel line, which revolutionizes climbing for hardcore fans and dilettantes alike. By using a complex system of electromagnets, the Skytouch can launch a small piton-hook up to 20 feet away, with enough force to pierce most forms of rock. Simply mount the rope on the hook, fire it into the stone, climb up the rope, repeat!

The Skytouch allows you to instantly ascend any overhang structure, or scale buildings at a rate of two stories at a time. Both of these may be done with one move action.

## **Atlas Outfitting Portable Wall (\$15000)**

### **Equipment**

Sometimes armor and shields don't cut it. Sometimes, the only way to truly protect yourself from your enemies is to put a fucking steel wall between you and them. Whether it's berserker mobs, zombie hordes, or floodwater, the Atlas Outfitting Portable Wall (affectionately named "wall-in-a-shawl" by its users) can keep it at bay, by unfolding from the size of a backpack to a six-foot long inch-thick wall of steel!

When deploying the Atlas Outfitting Portable Wall, select up to five squares in a straight line. Make a hardware roll. Upon a successful roll, the indicated spaces will be protected by a thin steel wall which can obscure line of sight. While this wall may be deployed in combat, it cannot be retracted until the environment is safe again. Finally, the wall may be overturned by a sufficient amount of brute force, to be dictated by the GM in any given scenario.

## **CorpTechs Jack/Hammer (\$15000)**

### **Equipment**

Have you ever needed and/or wanted to move something really really heavy? Of course you have, everyone has. Thusly, CorpTechs the Jack/Hammer. No larger than your forearm, the Jack/Hammer can be affixed to the side of anything that needs to be propped up; and then uses a combination of nanofluid and self-monitoring pneumatic pistons to explosively turn it on its side! That's not all, though—the Jack/Hammer can be affixed to doors of varying sizes, and there engaged, whereupon it will force the door inward with a burst of explosive energy.

When using a CorpTechs Jack/Hammer in jack mode, you may target cars, dumpsters, or other freestanding cover objects as the GM sees fit. You may then make a hardware roll; if this succeeds, said object now blocks line of sight like a wall.

When using the CorpTechs Jack/Hammer in Hammer mode, make a hardware roll at no penalty. Upon a successful roll, the door will explode inward and do 1d5 damage to anyone standing within three squares' proximity. Upon a failed roll, you will injure *yourself* for 1d5 damage. This always alerts everyone within 10 squares.

## **APSF Glass Cutter (\$7500)**

### **Equipment**

So, say for example you want to move through a point in space which is occupied by a breakable transparent material with a molecular makeup identical, or at least extremely to, industrial glass. You could jump through it and risk lacerations and blood loss; you could shoot through it, and risk alerting the locals; or—hear me out here—you could use a rotary plasma saw/plunger combination to cut a hole through it, effortlessly walk through that hole, and then replace the glass where it was a moment later so nobody is any wiser.

While you have the APSF Glass Cutter equipped, you may choose to spend an action to cut through any given panel of glass, any number of times. After this action is concluded, you may pass through the panel without taking damage, without shattering it, and without alerting enemies who encounter it. Alternatively, you may attempt to do this without use of a dedicated action, and instead make a hardware roll to achieve the same result. Failing said roll will cause the glass to break as normal.

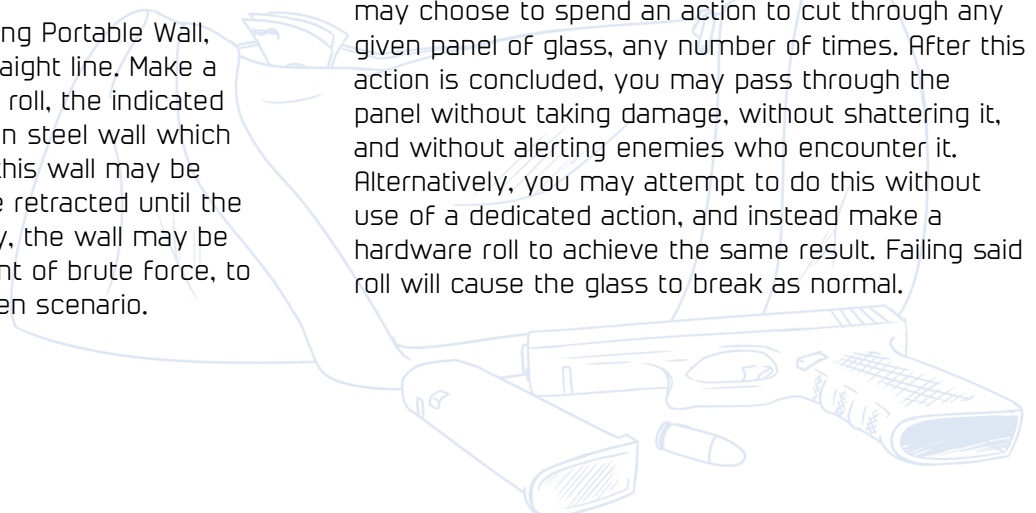

### **Apogee Satana Deafener Gauntlet (\$12000)**

**CAP: 3 | RNG: 0 | DAM: N/A | Boots | Doohickey**

A lot of people have sensitive ears—Most particularly animals and superheroes. It's only natural that the unscrupulous felons at APSF would find some way to exploit that. Thus, the deafener gauntlet: a small speaker which produces feedback noise over multiple audio bands, and makes everybody grab their ears and run for cover. Lucky for you it comes packaged with earplugs.

Any enemy who is within range (ignoring cover) of a Deafener gauntlet when it is activated will be forced to make a grit roll at a -2 penalty. If they fail, they will be forced to retreat to the edge of the radius as far as their movement speed allows, and may not take any other action that combat round. The Deafener does not affect friendly targets or robots.

### **Heavy, Blast 7, Targeting Software**

### **Apogee Satana Glass Ruining Agent (\$5000)**

#### **Equipment**

Do you hate being seen, and love making money? APSF does too, and they can do both with their Glass Ruining Agent. Representing the unparalleled powers of pettiness afforded by the nanotech age, the APSFGRA does exactly what it says on the tin: specifically, it seeks out glass, spreads itself over it, and uses a carefully-crafted mixture of cameras and refractive metals to quietly render it absolutely useless!

When you use the Apogee Satana Glass ruining Agent, designate a single window of any size to which you are adjacent, and then roll hardware. If this is successful, the window becomes opaque but does not alarm anyone.

**Limited-use: 1**

### **CorpTechs CLOP (\$45000)**

**CAP: N/A | DAM: N/A | RNG: 25 | Long**

Grenades have been an integral part of combat for centuries, and will remain so for many more: there's basically always going to be a market for tomato-sized bombs which you can throw at people. The only real obstacle to consider with grenades is, simply put, how far you can throw them: and since many soldiers in the modern age either do not want or cannot house strength-augmenting prosthetics, it has long been popular to employ special grenade launching machines: and among combat engineers and squad commanders, few such machines are as popular as the CLOP. Affixed to the back, and intended for use by support specialists, the CLOP uses a cybernetically-controlled low-yield railgun to

project any NASTA-compliant sublethal explosive munition with tremendous range and accuracy—allowing its wielder to manipulate complex situations from relative safety. Thus, the CLOP is a valuable asset in any military squad.

While the CLOP is equipped, you may treat any weapons with the 'throwing' type and the 'idiot-proof' trait as if they had range 25 and the 'artillery' trait. However, you must make a successful hardware or hacking roll to utilize this effect.

### **CorpTechs Industrial-Use Zipline (\$12500)**

#### **Equipment**

The CorpTechs Industrial Zipline was originally patented and distributed as a way for hikers, explorers, and infantrymen to easily move large packages through difficult environments. Through use of an electromagnetic projector and a pseudo-nanocolony, this forearm-sized device can create a durable and tautly-secured zipline, which can move any cargo under three hundred kilos safe, and at a rate of almost two meters per second. This naturally has made it invaluable to Operator infiltration and assault teams alike—both of whom can benefit from rapid transit, of themselves and of their recently-acquired valuables.

When you use the CorpTechs Industrial-Use Zipline, designate any point up to 50 tiles away from you, and roll hardware. If this roll is successful, place a zipline token at the designated point and at your current location. You, your teammates, and any storage bags or items you may be carrying can then move between the two locations, at a rate of 20 tiles per action. Moving in this way consumes a move action, and you may double move in this way if you so choose; however, you will always remain silent while doing so, as though you were moving in the **crawl stance**. While on a zipline, you count as being in cover from all enemies who may wish to attack you; however, all enemies you can see count as being in cover from you, regardless of whether or not you have a clear line of sight to them. After beginning to ride a zipline, you may choose to prematurely stop your passage and hang in place; and then start it back up again at your leisure. You may prematurely detach from a zipline if you are so inclined; however, if you do so, you will have to make a successful athletics roll, or else suffer 1d6 impact damage. Only one person or object may ride the same zipline at any given time.

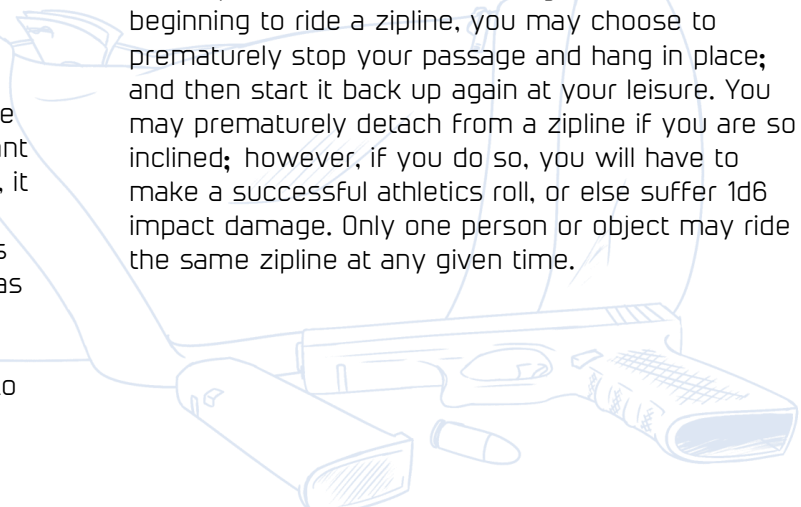

# Calculators and Computers

## Commandante 6400 (\$2000)

**CAP: INF | DAM: 0 | RNG: 0 | Equipment | Computer**

It weighs forty kilos, it's made of plastic, it sounds like a rocket taking off, and its screen only displays two of the three colors of light. It's the Commandante 6400: one of the oldest computers still on the market. With a paltry 124 gigabyte memory and 4.2 GHZ processing speed, these old lugs can barely run a game of Uberpong. That being said, at least they're cheap and portable...and isn't that what matters?

**Processing 1**

## Hackmate QThousand Slicing Tool (\$10000)

**Equipment**

Operator's work is dirty and tense: you're working on a clock, with a few seconds to breathe in between gunshots. That's no place for a hacker—and with the Hackmate QThousand, you'll be able to leave all that behind you! That's because the Hackmate QThousand is a state-of-the-art wireless uplink tool, compatible with USB, which can transmit up to 100 feet with 0% packet loss and a delay measured in the single-digit milliseconds. All you do is plug it into your computer, retreat to a comfortable distance, and hack away to your heart's content with no witnesses, and no guards!

The Hackmate Qthousand can be inserted manually into any hackable object to which the user is adjacent. Doing so grants all allied hackers physical access to the device, regardless of distance, until it is removed. The Hackmate Qthousand can be removed at no action cost by anyone standing adjacent to the hacked device.

## CSC-Comdom-6 (\$15000)

**CAP: INF | DAM: N/A | RNG: 10 | Compact | Computer**

The CyberSects Conglomerate Comdom-6 is currently one of the most successful personal computers on the market—not only for its ease of use, but its unrivaled style. Mounted on a black rubber glove that easily and snugly fits over almost any forelimb, the Comdom uses a complex motion sensor to read keystrokes with precision. While it does most of its trade in the legitimate market, any hacker with their salt can jailbreak this baby into a superweapon of cyber warfare.

**Targeting Software, Processing 3**

## CyberSects ComDom-7 (\$25000)

**CAP: INF | DAM: N/A | RNG: 15 | Compact | Computer**

The CyberSects ComDom-7 is a strict upgrade over its predecessor, and now this little rubber is better than ever. Sporting all new optimized sequence generation and a brand new focused wireless emitter, the ComDom is capable of piercing harder targets than ever before—and as a big "thank you" to all the fans, CyberSects has released this one without deliberately screwing the Model 6!

**Targeting Software, Processing 5**

## Midnight Road Inc. Blacktop Model 5 (\$10000)

**CAP: INF | DAM: 0 | RNG: 5 | Equipment | Computer**

A good three quarters of this job is in information. Information is what you get contracted to steal, and it's what you need to keep from being jumped and ventilated by some hopped-up night guard. Fortunately, the wonderful crooks at Midnight Road created something special for all this—the Blacktop Model 5, the finest Operator's computer ever developed. The beauty of the Blacktop 5 is that it is not strictly a computer, but rather a small colony of nanobots, which can be leashed to a laptop of your choice. While dormant, these nanobots arrange themselves into the form of a small digital watch; but on command, they power up and migrate into the designated device, load the Blacktop Firmware, and encase it in a stylish-as-hell bulletproof casing. Then, as soon as it shuts down, it uninstalls itself and resumes its dormant form until its next use.

The Blacktop-5 is the preferred platform for several highly illegal softwares, which makes it invaluable to hackers all around the world. Additionally, it comes equipped with a pre-baked suite of code cracking and Footage-scrambling software.

**Processing 5**

## Mindhack.exe (\$7500)

**Processing Cost: 1 per Execution**

When you're locked in a battle of wits, the easiest way to win is to distract and frustrate your opponent until they throw up their hands and walk away. Enter the Mindhack program: the excitingly-named but disappointingly mundane program which floods your enemy with spam messages. If you can't beat em, annoy em.

While you have Mindhack.exe installed AND executed, anyone who loses a hacking clash against you also loses an action on their next turn.

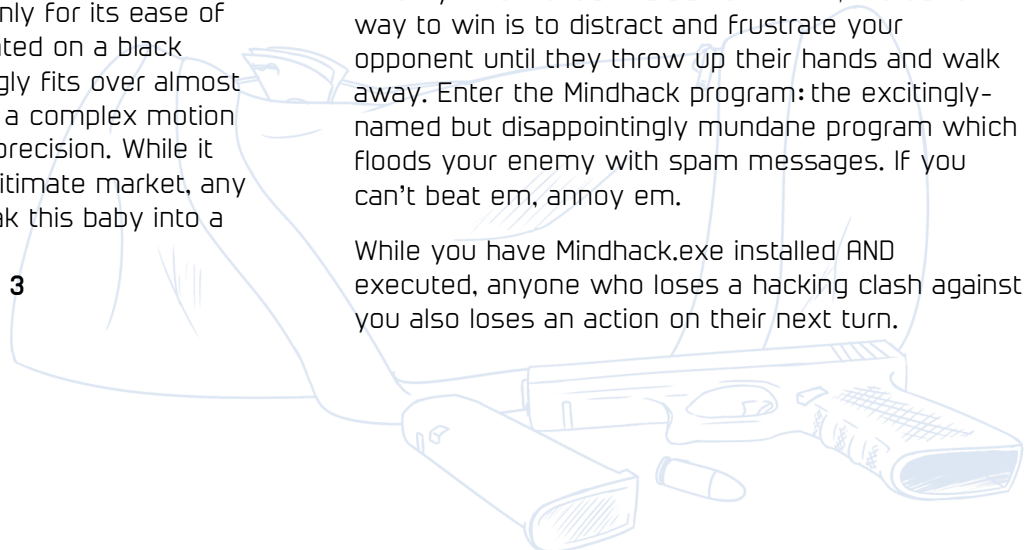

### **Pawprints v 1.3 (\$8500)**

#### **Processing Cost: 5 per Execution**

Arguably one of the most important pieces of software an infiltrator can have. Pawprints is a program in two parts: firstly, it is a small cluster of nanomachines, which are mounted in a spray can. Said spray can be modified into paint, cologne, or a simple silent projectile—but regardless of what form it takes, it serves the same purpose.

It embeds itself in the target's fur, hair, or feathers, and remains there for up to forty-eight hours; and during that time, it steadily relays information about their target's position back to a pre-determined device. This allows hackers to provide their team with live updates on an enemy's position, or compile information to predict future movements—and that can make all the difference in the world when you're trying to break into a secure location.

### **WallFlower v 2.2 (\$7500)**

#### **Processing Cost: 2 per Active Camera**

What you can't see can easily hurt you, but what you *can* see probably won't. It's important to have eyes in as many places as possible—and the fastest way to cover all the exits is with the Wallflower surveillance suite. Each Wallflower is a small black-dome camera measuring 2.5 inches across, which continuously provides an uninterrupted panoramic display to its master computer. At present, a single install of WallFlower can support up to eight wallflower cameras, but by default it only comes with two.

Each wallflower camera reveals a distance of eight squares, and is vulnerable to smokescreens or other visual obstructers. Each additional camera costs 500 hands.

### **Missouri DigiStructure v 2.0 (\$2500)**

#### **Processing Cost: 5 per Execution**

The latest and most nefarious program in the venerated Missouri smart-diagnostic programs, the Missouri DigiStructure program uses a complex series of spatial recognition and geometric models to accurately locate the load-bearing points of any given building. It's as simple as firing the program up and giving your computer's on-board camera a good look at your surroundings, and you're off to the races!

"The Races" in this case being "blowing things up, with bombs".

When using the Digistructure, make a hacking roll. Upon a successful roll, structural weak points in the room are revealed to you.

### **Wingding V 1.0 (\$15000)**

#### **Processing Cost: All of It**

Why, might you ask, is an install of Wingding so expensive? Because it comes equipped with a fully-functional remote control quad-rotor miniature helicopter, which is capable of silent 360 degree movement, and comes equipped with two panoramic cameras to give you a field of view to match. Amazing.

The wingding Quad-copter is controlled by a hacking roll, with a stacking -1 penalty being awarded for fifteen squares it has moved after deployment: this costs 1 action. The Wingding copter may relay footage of everything a 8-square radius around its position, discounting things which cannot be seen by the naked eye. The Wingding cannot move through locked doors or any kind of window, but may move through regular doors. The Wingding, while in stealth mode, is invisible to the naked eye, but can be seen by thermal imaging, and may move 15 spaces per turn.

### **Skinbook v 0.3 (\$2500)**

#### **Processing Cost: 3 per Execution**

The internet, as they say, never forgets—and with an install of Skin, neither will you! Skinbook is a state-of-the-art database maintained by legions of internet trolls, corrupt cops, disgruntled intelligence agents, advanced sorting algorithms and stalker savants, which tirelessly compiles over thirty and a half billion people's arrest records, social media activity, and anything else they let slip. This means that all you need to do is take a reasonably clear picture of your targets' face, and you can instantly know everything from their blood type to their porn habits! Some might say this is a grotesque violation of privacy and civil liberty, but we say "we're criminals—who cares?!"

When you use Skinbook on a target, the GM must disclose the details of their social media habits, employment, birthday, family, and pornography consumption at your behest.

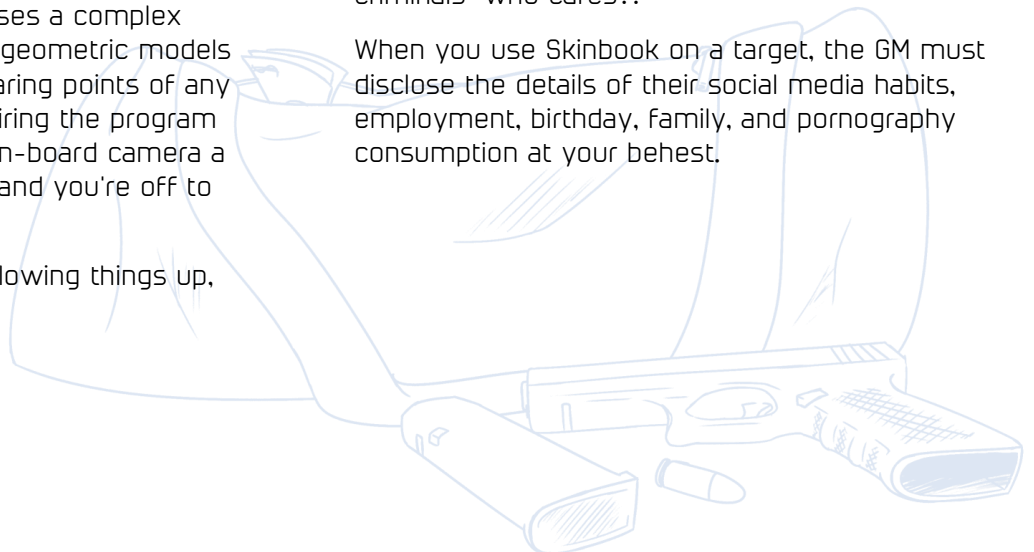

### **Snootle.exe (\$15000)**

#### **Processing Cost: 2 per Execution**

One of the pleasingly exploitable realities of the Doublearth is that a large number of wifi-enabled augments and devices are mounted on the legs, chest, or neck—all of which are prime targets for Snootle.exe. The only surviving product out of Midnight Road's ill-fated behavioral science division, Snootle.exe causes any ID tags, AR interfaces, helmets, or the like to very briefly vibrate while emitting a low-pitched humming noise. This will distract, confound, and in some cases very drastically upset them—for about 2.5 seconds.

When you have Snootle.exe installed, and are interfacing with a hackable item on your enemy's person, you may roll hacking. Your target then rolls grit at a -x penalty, where x is half your hacking score. In the event that you succeed and they fail, the target loses an action on their next turn.

### **Omniscience v 3.0 (\$5000)**

#### **Processing Cost: 3 While Active. Per Instance**

While Omniscience doesn't actually make you omniscient, it does give you the next best thing. Omniscience is compatible with most eye augmentations or third-party augmented reality glasses—which, in brief, allows you to share your allies' vision. This can be an invaluable tool for snipers, artillerymen, or infiltrators—for obvious reasons.

Omniscience v 3.0 allows you to share fields of view with any one target member of your party, even once combat has been engaged. This does not necessarily give you line of sight to the enemy, but does allow you to attack them with **Artillery** weapons.

### **No.exe (\$15000)**

#### **Processing Cost: 1 per Execution**

No.exe is simple to describe, while simultaneously being a clever feat of computing. By employing a bleeding-edge algorithm, No.Exe is capable of analyzing the random inputs of code-cracker programs and predicting their next guess with near-40% accuracy. In the event that it predicts a breach in your defensive network, No.exe will instantly alter your encryption keys, thus averting disaster. In theory. In practice, it's a very finicky process that has a decidedly low chance of working.

When you have no.exe installed, you may roll hacking at a -6 penalty when you fail a hacking Clash. On success, reroll the clash. You may only use no.exe once per clash.

### **Memes.exe (\$15000)**

#### **Processing Cost: 2 per Execution**

Memes. Memes are the bane of the internet, which no sound mind can countenance. Memes are deplorable, shameful, and popular. Fortunately, you can use this cultural cancer to your benefit. Memes.exe is a spam program designed to focus with AR displays of the sort commonly used by the Ministry and Police. If you are seen at an bad moment, memes.exe can quickly flood their AR with popup windows of JPEG files from popular websites. While in more stressful circumstances this would cause them to shut down their AR and engage pursuit, this usually serves only to focus their attention elsewhere when employed in a peaceful environment. Usually.

When you have memes.exe installed, you may roll hacking whenever an enemy makes a suspicious person roll. In the event that succeeds, you may force them to reroll.

## **The NearDoWells Necessities: Tools For Con Men, and Their ilk**

### **Electric Eye ID for Everything (\$10000) Equipment**

While the Electric Eye Company is most famous for its ubiquitous Operator's Manual, its other work should not be forgotten. One of their most valuable tools in these endeavors is their iconic "ID for Everything". While it is no larger and no more powerful than a phone, it serves a uniquely valuable purpose: namely, the ability to scan and replicate ID cards with near-flawlessness. It's a simple device: by simply inserting an ID badge belonging to any given organization into its paper-thin slot, the IDFE can replicate all the requisite logos, insignias, and biometric data—as well as a photograph that you provide. In this way, it is possible to forge an ID for virtually any occasion, without the potential alert risk that simply stealing one poses.

The EEIDFE lets you forge security credentials of any kind, so long as you have a genuine sample which you may imitate.

### **Coral King Siren's Kiss Lipstick (\$5500) Equipment**

It's poisoned lipstick. Comes in lethal and nonlethal varieties. Cherry flavored.

Nuff said.

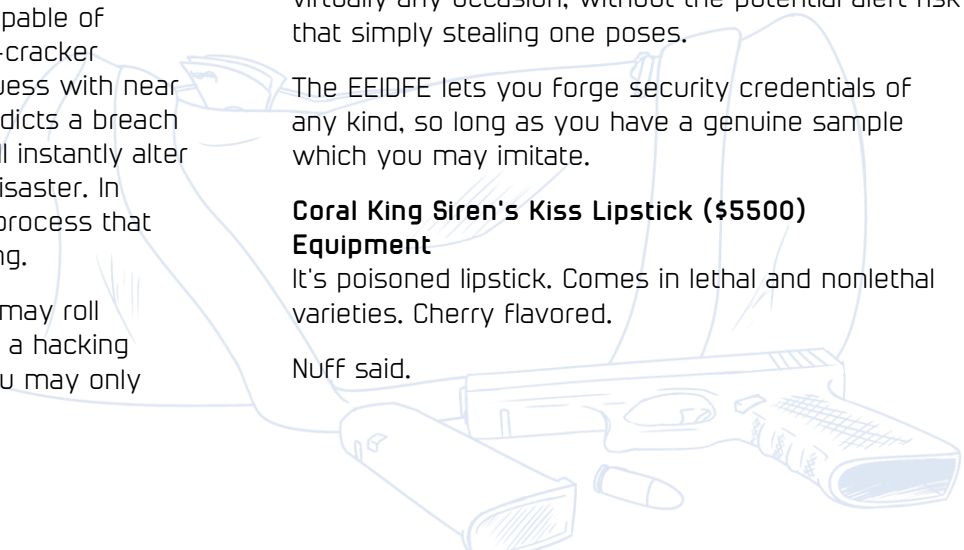

### **Coral King Deadly Viper Dart Launcher (\$5500)**

**RNG: 4 | CAP: 1 | DAM: 0 | Compact | Arrow**

Another one of Coral King's most famous products is their Deadly Viper Dart launcher—a discreet dart-launching apparatus that is so small it is almost undetectable. Its miniscule size, however, means that it's not as powerful as more conventional projectile launchers, and can only be fired a few feet at most. What this means is that the Deadly Viper is a weapon that must be used carefully, and requires planning to execute. Fortunately, a complex network of small sensors allows the Deadly Viper to be programmed to discharge only when you take the position of your choice, thus allowing you to more readily bait your marks—either into a hug, or something more intimate.

You may have up to five deadly viper dart launchers equipped in a single slot at once. You can, if you are so inclined, purchase the Coral King Non-Deadly Deadly Viper Dart Launcher—which fires tranquilizers—for the same price.

**Limited-use: 1, Assassin 4, Nonlethal (optional)**

### **CorpTech EZDye (\$5000)**

#### **Equipment**

Dying hair is troublesome. It always has been, and it was always going to be—at least until CorpTechs Engineering brought the EZDye to the mass market. Reverse-engineered from experimental vehicular camo, the EZDye is a water-soluble nanite cluster-cologne which can be applied at home, at work, or anywhere else; and by simply speaking "CorpTechs Color [Desired Color]" into the built-in microphone on the can, you can instantly color the sprayed areas any color you desire\*!

\*Colors defined and coordinated according to the Home and Garden association of Canada color coordination index of 2300, excluding flesh marble, pink marble, and chartreuse.

It does exactly what it says in the ad blurb up there. Remember: water-soluble.

### **Coral King Sinnermon Hair Additive (\$5000)**

Another one of the big Operator "Companies" is Coral King—a group that caters to faces and infiltrators, by providing a collection of varyingly lethal poisons and paralytics, which can be stealthily applied with a number of innocuous gestures. One of their flagship products is the Sinnermon Hair Additive—a highly potent tranquilizer and paralytic that masquerades as a hair additive.

If you can get somebody to sniff the part of your body that you have applied Sinnermon hair additive to, they will be rendered unconscious immediately. Useful for seduction, or working out at the gym.

### **APSF Rubber Check (\$2000)**

#### **Equipment**

Let's be frank here: the face life is expensive. Whatever you don't spend on roofies and fetish outfits, you'll probably spend on bribes and party drugs. Fortunately for you, the mad geniuses at Apogee Satana are perfectly aware of your plight, and have created the handy dandy Rubber Check for your use. This simple device is a piece of custom-built malware installed in the body of a 10000-hand chit, which is fully compatible with normal chits and counterfeits. When hooked up to a banking device, this little beauty sends a dummy message that registers a transfer of any amount of money you want—in essence, "tricking" the device, and its wielder, into thinking they've just gotten richer. The dummy program will fall apart as soon as they take it to an official banking institution, but you'll be gone by then.

When you use the APSF Rubber Check, you can pay someone any amount without losing any money. This does not consume the Check.

### **APSF Zip Ties (\$500)**

#### **Equipment**

You've all been there. You're robbing a liquor store or a bank or something, and somebody keeps trying to run away and call the police. Normally, you'd have two options here: Either shoot the poor creature, or get your ass chased by the police. But what if there was a better way? Thanks to the tireless labors of APSF, now there is! The APSF Zip Tie is a revolutionary new device—a pair of shackles made out of hard plastic, which are lightweight, durable, and easy-to-use! By simply wrestling your victim to the ground, inserting their forelimbs into the patented Uncomformax™ restraining sleeves, and then pulling the tight zipperlock design, you can hobble any horse, human, or other sapient!

The APSF Zip Ties can be used to indefinitely incapacitate anyone who has offered you their surrender—which is to say, been compliant with a Freeze! Action for one or more turns. While incapacitated by the APSF Zip Ties, you cannot move, attack, or use items. The APSF Zip Ties may be broken with another person's help, at the cost of one action.

**Limited-use 1, Disposable, Idiot-proof, Stackable**

## Calling Card (\$500)

### Special

A calling card is a very special item and is not something to be taken lightly. It is a signature, left at the scene of your crime to let investigators know that, even though you were too careful and cunning to leave a single trace of your passage, it was most certainly *you* who did the crime! Calling cards are unique to each gang, and are necessarily bombastic and memorable. Your own calling card—if indeed you acquire such a thing—can be nearly anything you want. It might be a literal calling card, with your names or insignia upon it; it might be something less orthodox, like distinctive graffiti; or it could be bizarre and horrible—a collection of bones, or worse! Whatever your calling card is, make it unmistakable, and unmistakably yours.

Your calling card is a special distinctive sign of your passage. It does not occupy a slot in your inventory. When you buy a calling card, you gain any infamy your actions on the next mission warrant, even if you leave no witnesses or evidence.

## Surgical Supplies

### Mediquick Nanobiotic Replacement Shot (\$1500)

The importance of augmentation to the average modern combatant is something which simply cannot be overstated. According to a survey taken in 54-6A, over 62% of professional combatants benefit from at least one commercially-available performance-enhancing augmentation; so the proliferation of EMP weaponry was only natural. Equally natural was the introduction of a counter-EMP Agent, in the form of the Nanobiotic Replacement Shot. This two-part injection simultaneously repairs the (nano)robotic and biological components of a given augmentation, and is programmed to recognize and repair over 300 different commercially-available augmentations. When administered by a trained professional it can reverse the effects of an EMP in a matter of seconds.

Restores functionality to all augments which have been disabled, over the length of one turn.

**Limited-use 1, Disposable, Surgical**

### Mediquick Splinting Kit (\$1000)

Splinting is a simple form of first aid for broken bones, which is taught to everyone from first responders to the foal scouts. The theory behind it is simple: when someone breaks a bone, you just

take one or two flat objects of about that length, affix them to either side of the affected limb, and then tie it in place using some kind of cloth. The Mediquick Splinting Kit is a selection of “smart” rods and fabrics, which can be folded like cloth normally, but become hard and form-retaining at the touch of a button—creating a space-efficient alternative to more conventional tools.

Repairs the effects of **fracture** or **cripple** clash results over one turn.

**Limited-use 1, Surgical**

### Mediquick Lazarus-in-a-Box (\$10000)

Nanotechnology is nothing short of miraculous, and the Mediquick Lazarus-in-a-box is the proof of that fact. The Lazzzy Box is a series of 38 different deep tissue nano-injections—which, when administered by a medical professional, are capable of dissolving foreign objects lodged in the body, repairing lacerated or ruptured tissue, and even mend broken bones. They are used in hospitals and clinics across the world to treat trauma patients; but only ever as a last resort. The lazarus-in-a-box is not only expensive, but invasive; and the treatment itself has a recovery period that is longer than many of the injuries it fixes.

Restores target to full health over three turns, at a rate of one third max HP per turn, but prevents them from gaining a power burst at the end of the mission.

**Limited-use 1, Disposable, Surgical**

### Mediquick Laceration Treatment Cream (\$1000)

In indoor and outdoor sports, the most common pains and injuries are the result of many small injuries, rather than a single large one. Muscle soreness, shinsplints, thicket and bramble lacerations—each of these shares a common cure, in the form of the Mediquick Micro-Laceration Treatment Cream. This cheap and effective medical paste promotes immediate clotting and scabbing, which can repair a wide variety of micro-injuries; however, it is not licensed for home use, and must be applied by a trained individual—in overlarge amounts, it can block pores, cause rashes, and even result in disfiguring but otherwise benign tumors.

Restores any health lost from glass or falling damage.

**Limited-use 4, Disposable, Surgical**

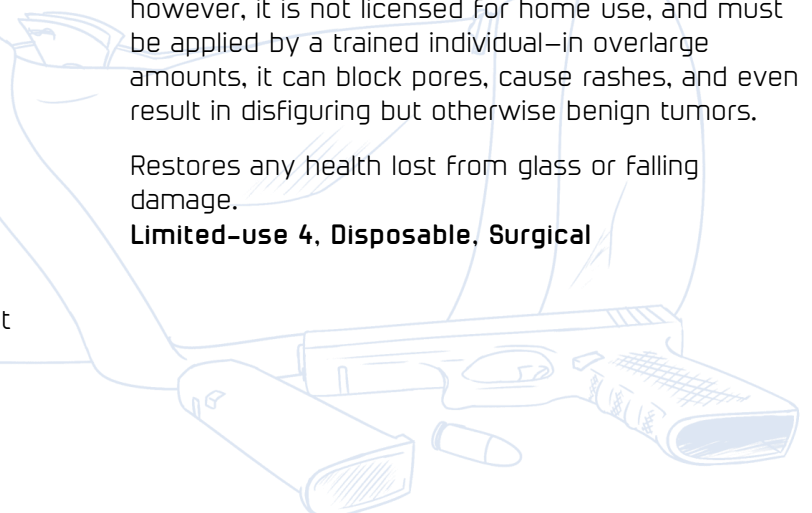



## **Drugs: Rock Cocaine. It isn't glamorous, or cool, or kid stuff.**

### **Nitrous Oxide (\$20000/CH)**

#### **Equipment | Drug | Duration: N/A**

Nitrous Oxide—also known as laughing gas—is the only reason to visit the dentist. NiOx induces feelings of intense numbness; and it takes between ten and thirty seconds to take effect, and about that long to wear off. Nitrous Oxide is one of the few things on this list that's legal to own...sometimes.

The duration of Nitrous Oxide is a number of encounters equal to its buyer's chemistry skill. After taking Nitrous Oxide, you gain invulnerable [x], where x is equal to a third of the number of points invested in the buyer's chemistry skill, rounding down. Movement speed is halved and you suffer a -4 penalty to all actions for the duration.

### **Amphetamine Salts (\$10000/CH)**

#### **Equipment | Drug | Duration: 5 Encounters**

Amphetamines—also known as speed, amp, crank, crystal, and BOB,—is the favored drug of soccer moms and trailer trash. Known for inducing one part superhuman energy, and one-part bees-in-your-teeth crazy, meth is what you take when you just want every single thing in the world to be a little more wild.

Gain +2 bonus to all rolls you make, but attacks made against you count as having +2 to their normal damage for the duration

### **LSD (\$3000/CH)**

#### **Equipment | Drug | Duration: 5 turns**

When you wanna get FUCKED. UP, you take LSD. This venerable and time-tested psychedelic has been the muse of musicians, scientists, and poets for longer than the EU has been around; and to open oneself to it is to open the door to the demons within yourself, and an understanding far without; to court delight and danger at once, in a dance which the somber and sober will never savor; and most of all, to get blasted.

When you take LSD, regenerate 3 IP each turn but suffer fear 4/10 for the duration.

### **Crystal Meth (\$10000/CH)**

#### **Equipment | Drug | Duration: N/A**

The bigger meaner brother of Amphetamine salts, Crystal Meth is a standby for maniacs and gangsters the world over. Sometimes you just wanna get the kind of jacked that ends with you wearing somebody else's underpants on your head while car-surfing down the freeway with a severed head in one hand and a bag of cash in the other—the kind that makes the world seem slower than it really is and hurt less than it actually does.

Crystal Meth lasts a number of encounters equal to its buyers' chemistry skill. Every time you get a KILL with a melee weapon, subsequent melee attacks inflict 2 additional damage for the remainder of the duration. Your max HP suffers a reduction equal to the number of enemies you ATTACK during the duration.

### **Cleaner (\$5000/CH)**

#### **Equipment | Drug | Duration: N/A**

Cleaner is a medical drug of some importance, and is widely employed in trauma centers around the world—and it is not to be confused with grease remover, dish soap, or paint remover: “Cleaner“ only cleans *people*, with a combination of opiates, delayed-release caffeine, and nano-steroids; the end result is, simply, a systematic purge of foreign elements in your blood stream, followed by a quick (if unpleasant) restoration of your normal functions. Commonly used in the treatment of overdoses, or by people who need to come off a high sooner rather than later.

Cleaner neutralizes the effects of any drugs or poisons on anyone who takes it.

## **Masterminds Menagerie: Plans, Schemes, and Inside Men**

### **Camera Tap (\$20000/MM)**

#### **Plan**

This simple wiretap is usually installed as part of a “maintenance checkup” or something else innocuous, and reveals cameras in the AO. Usually installed in a power junction, it uses electricity much like sonar as it flows through wires—mapping the places where they terminate, and relaying that information back to whoever planted it there.

After buying Camera Tap, begin the job with knowledge of all camera locations and types.

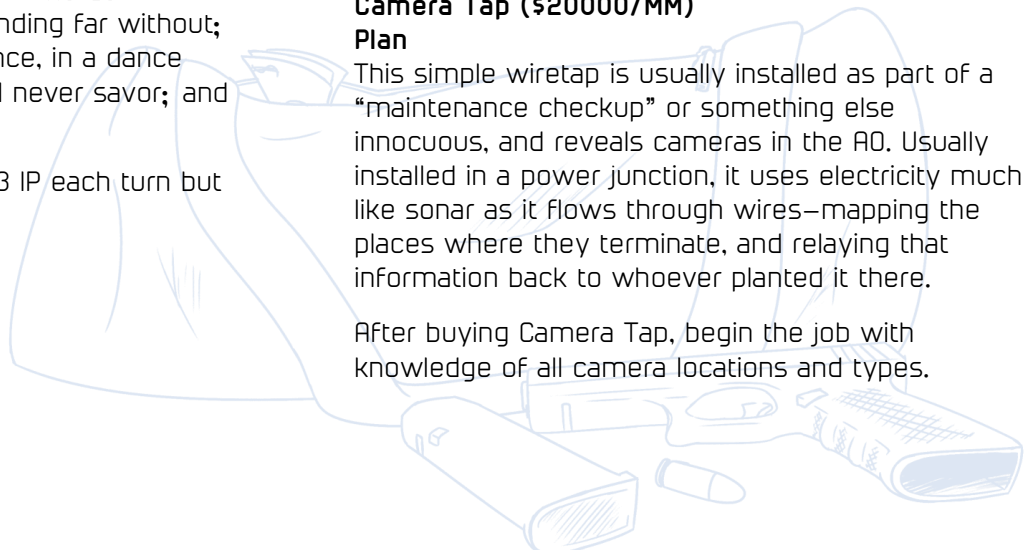

### **Camera Tap+ (\$60000/MM)**

#### **Plan**

This is a more complicated and complete camera tap, which usually has to be set up from the security terminal which the cameras feed to—or else, on the cameras themselves. The extra effort and expense is worth it, though: not only does it show you where cameras *are*, it allows you to hijack the target's surveillance for your own use.

After buying Camera Tap+, begin the job with the cameras relaying their fields of view to a computer of your choice, at no PP cost.

### **Inside Man (\$10000/MM)**

#### **Plan**

An inside man is one of the most valuable things a thief can have. He's a thief, janitor, teller, or someone else of low consequence and lower pay. They will be happy to give you some blueprints, and then take a few days off work.

Begin the game with a single floor of the map revealed to you, excluding security measures, fuseboxes, and areas which the GM deems secret.

### **Inside Man + (\$30000/MM)**

#### **Plan**

A significant sum of money can get you a significant deal of help. By bribing an architect, city planning executive, or shift supervisor, you can get the whole layout of a building before having to do any actual recon yourself.

Begin the job with the entire map revealed to you, excluding security measures, fuseboxes, and areas which the GM deems secret.

### **Guard Schedule (\$25000/MM)**

#### **Plan**

It's hard to be surprised if you know where everyone's going to be before they get there. Acquiring a copy of the guard schedule for your next hit will make sure you know where to be, and when to be there.

Begin the game with the guard patrol paths highlighted on the map.

### **Security Hole (\$5000/MM)**

#### **Plan**

If you can't get around a security measure, sometimes going through it is the better option. All you need to do is pay a man on-site to find the right hole in the right place, and then just waltz on through.

A single security device of your choice will not register your presence. The players may use this asset when they encounter a security device, but before it has already detected them.

### **Turncoat (\$10000/MM)**

#### **Plan**

Maybe you know where he lives. Maybe you got some pictures he wouldn't want his wife to have. Maybe you just gave him some money. Either way, the effect is the same: he's in your pocket, just waiting to show his colors.

A single 1-point enemy will turn a blind eye to you, and take off running if you engage combat with other enemies.

### **Traffic Jam (\$10000/MM)**

#### **Plan**

There's lots of ways to cause a traffic jam. You can pay a member of the city transit authority to screw with a set of lights. You can have someone park a really big car in the middle of the street. You can just blow up the road. Whatever.

When you buy Traffic Jam, it has no immediate effect. However, if the police are called in your next mission, the police response timer is increased by 1 turn.

### **Henchman (\$500\*SP\*(11-MM))**

#### **Plan**

When you need somebody a little less reliable and a little less expensive than a typical contracted goon, that's when you log onto the darknet and hire a henchman. Henchmen can do just about anything—kill people, drive cars, do your laundry, all that jazz. But, they only do it as long as you keep paying them, and they can charge quite a lot.

Henchmen are NPCs which you control and can have up to 36 skill points. You may assign their skill points any way you want. A henchman's cost is equal to five hundred hands, times their skill points, multiplied by X, where X is eleven minus your Mastermind score. We know, kind of a mouthful. They begin the game under your control and will remain such until the end of the job on which they are deployed. A player may have any number of henchmen but is expected to provide the tokens for each one.

Henchmen do not come with any items, but are assumed to return any that you lend them at the end of a job.

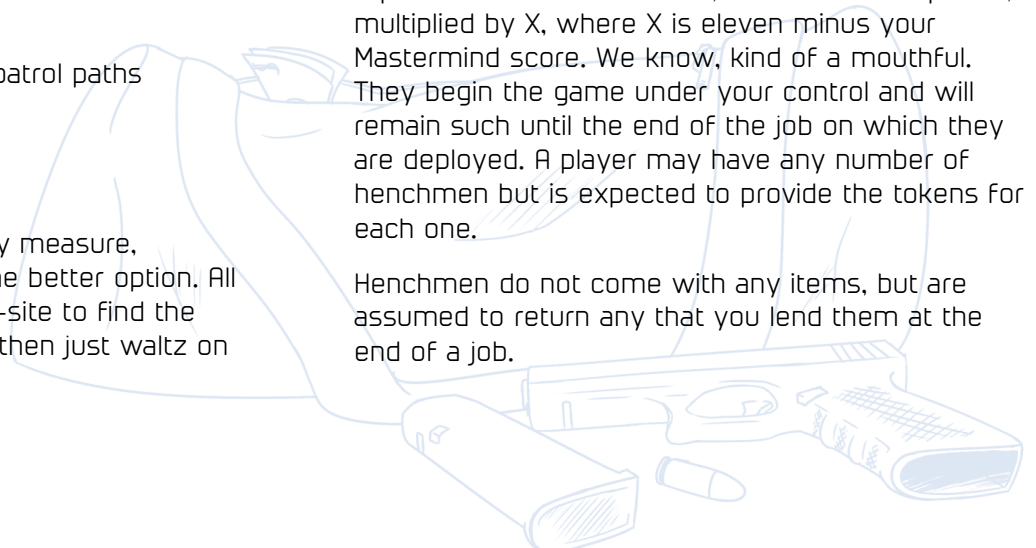

## Getaway Driver (\$20000/MM)

### Plan

When you need to get away in a hurry, it's always a good idea to have a redundant escape point. This comes in the form of a getaway driver—a man with a spare car, who knows how to make it go real fast. Pile in and hit the gas.

When you buy a getaway driver, place a 4x6 escape zone on any road. This can be done in-game or before the game; doing this in-game has a delay of 1d5 rounds. This escape zone is taken to be a representation of a physical vehicle, and may be targeted by enemies. It will cease functioning if it takes 30 damage.

## Getaway Pilot (\$50000/MM)

### Plan

Sometimes you need to beat a hasty retreat and an escape car just won't cut it—maybe you're in a high-rise, or on a roof, or the floor is made of sharks. Either way, that's when you need a pilot—they bring their own helicopters.

When you buy getaway pilot, place a 4x6 escape zone anywhere that is not inside a building. This can be done in-game or before the game; doing this in-game has a delay of 1d5-2 rounds. This escape zone is taken to be a representation of a physical vehicle, and may be targeted by enemies. It will cease functioning if it takes 30 damage.

## BOMBS! And some Grenades Too

### Kessler Muni. Whizpop Grenade (\$6000-EX\*500)

**CAP: 1 | DAM: 0 | RNG: 8 | Equipment**

#### Thrown, Bomb

When it's vitally important to clear a room without risking collateral or property damage—such as hostage situations, or surprise parties gone horribly awry—there is perhaps no piece of equipment more vitally important than the flashbang. The flashbang is capable of briefly dazzling and disorienting anyone caught in the brief radius without killing them (usually). The ones commonly purchased by operators are old surplus models, and usually lack the explosive pungency of their modern versions.

Any enemies caught in the blast radius of a Kessler Whizpop Grenade may not make any reaction shots as the result of standing in guard mode until their next turn.

**Blast 2, Limited-use 1, Disposable, Idiot-Proof, Stackable**

### Kessler Muni. Territorial Anticyborg Chaff Overcast Grenade (\$5000-EX\*200)

**CAP: 1 | DAM: 0 | RNG: 8 | Equipment**

#### Thrown, Bomb

Continuing its theme of using explosives to counter a better-equipped force, Kessler Munitions debuted its series of chaff/EMP grenades for use against the feared cyborg commandos of the American armed forces. By releasing a smokescreen of fine-grain electrified particles into the air, these simple devices are able to scramble the effects of augments and other electronic devices within a small area around the blast zone—which, as it turns out, is pretty much all you need to avoid being murdered in the face by a scary cyborg.

**Blast 2, EMP 2, Limited-use 1, Disposable, Stackable**

### APSF Smoke Grenade (\$3500-EX\*100)

**CAP: 1 | DAM: 0 | RNG: 8 | Equipment**

#### Thrown, Bomb

In this business—or any business involving combat, really—what you don't see is just as important as what you *do* see. The Apogee Satana Foundation is well aware of this, and has seen fit to rectify this situation by reinventing one of the old standbys: the smoke grenade. Consisting of a pressurized smoke solution, the APSF Smoke Grenade will distribute a cloud of thick smoke over the designated area, blocking off line of sight through it. This can be used for rapid repositioning, to escape superior forces or to lay an ambush.

Any square hit by the Smoke Grenade's blast is filled with smoke for the duration of the effect. This smoke blocks line of sight to anything not immediately adjacent the affected space.

**Blast 3, Limited Use: 4, Idiot-Proof, Contaminant 4**

### Kessler Muni. HF Mk1 Fragmentation Grenade (\$10000-EX\*500)

**CAP: 1 | DAM: 10 | RNG: 8 | Equipment**

#### Thrown, Bomb

The *Handifragmintir* Mark 1—also known as the Hi-fi, because everyone enjoys silly nicknames—was a military-grade explosive initially produced for the Russian interest in Vietnam 2. Unfortunately, its incredible stopping power worked with its ease of use to create a truly startling number of friendly fire and self-inflicted wounds. As a result of this, the HF-1 very quickly fell out of fashion, and has since coasted along on the graces of military surplus dealers.

**Blast 1, Limited Use 1, Disposable, Pierce: Mesh, Stackable**

### **Kessler Muni. Lightboom Grenade (\$12000-EX\*1000)**

**CAP: 1 | DAM: 2 | RNG: 8 | Equipment  
Thrown, Bomb**

And then if you want a real man's flashbang grenade, you can pop one of these sick babies on your utility belt and scorch the eyebrows off of somebody. The Kessler Lightboom Grenade debuted in 2264, and is still a top-of-the line nonlethal grenade: packed with a significantly larger light charge, as well as a small helping of phosphorus, the Lightboom is popular among assassin teams and riot police, due to its ability to simultaneously blind and inflict first-degree burns. Definitely a smart buy, if you can afford it.

Any enemies caught in the blast radius of a Kessler Lightboom grenade may not make any reaction shots as the result of standing in guard mode until their next turn. Moreover, any enemies affected by it must make a grit roll at a -X penalty, where X is the number of actions they took last turn. If this roll fails, they lose their next turn.

**Blast 3, Limited-use 1, Disposable, Idiot-Proof, Nonlethal, Stackable**

### **TCE Meltdown Grenade (\$10000)**

**CAP: 1 | DAM: 10 | RNG: 8 | Equipment  
Bomb, Energy, Thrown**

Nobody—but NOBODY—wants to get in the way of this thing. Developed by the notoriously immoral Tartarus company during Vietnam 2, the Meltdown Grenade is a radiochemical explosive that produces quicks-evaporating discharge which is capable of searing your enemies' flesh, poisoning whatever's left of them, turning the surrounding area into a lethal hellscape for about 18 seconds, and then neatly dissipating. Handle with extreme caution or die horribly.

**Blast 2, Radiation, Poison 5, Contaminant 3, Limited-use 1, Disposable, Stackable**

### **Molotov Cocktail (\$5000-EX\*500)**

**CAP: 1 | DAM: 2 | RNG: 8 | Equipment  
Thrown, Bomb**

Explosives are expensive. This is an inconvenient but inalienable fact of the operating life—one which was easily circumvented. The molotov cocktail is what you get when you take gasoline, styrofoam, pure rubbing alcohol, and a few other things, then stuff it all in a glass bottle and set it on fire. While the resultant blast isn't necessarily really powerful, it is *really* hot.

**Blast 2, Burn 3, Limited-use: 1, Disposable**

### **Kessler Munitions Napalm Bomb (\$10000-EX\*500)**

**CAP: 1 | DAM: 0 | RNG: 8 | Equipment  
Thrown, Bomb**

While Molotov cocktails are perfectly fine for setting people on fire, the quick-burning flame of most accelerant-based grenades is ineffective as an area denial method: ergo, a more specialized form of dispersal unit is required. The Kessler Munitions Napalm Bomb is uncreatively named, but performs its function admirably. This baseball-sized beauty disperses half a liter of napalm over an area roughly the width of a large hallway, and cooks it off after approximately six seconds. The resultant flame burns with remarkable heat for about half a minute, and then fizzles out. The ideal thing to deny an advance from zombies, mutants, samurai, or any other thing that likes to run at you.

**Burn 5, Blast 2, Contaminant 6, Limited-Use 1, Disposable**

### **C5 Explosive (\$30000/EX)**

**CAP: 1 | DAM: N/A | RNG: 1 | Equipment | Bomb**

On the other hand, sometimes cheap shit just won't cut it. For when you need to bring down something that a Molotov or grenade cluster can't, there's always a good old Carryable Clump of Cool Cacophonous Cabooms—that is to say, C5. While this stuff isn't smugglable or tossable or any kind of combat-effective, it's sticky and shaped and it hits like the stomp of an angry god. While it makes a poor landmine due to its limited blast and a worse grenade because of its intense size, this thing will bring down just about any wall you put it on.

A C5 explosive charge cannot be used against an enemy as a weapon, and can only be affixed to walls, floors, windows, and doors. It takes two actions to set up properly. However, it is capable of destroying parts of a given environment. With a single detonation, it may remove three squares of any thin wall—one on each side of the device, and the one where the device is mounted; one square of any thick wall—where the device is mounted; it may punch clean through any non-blast door or non-bulletproof glass surface; or it may destroy the structural weak point to which it is affixed.

**Limited-use: 1, Disposable**

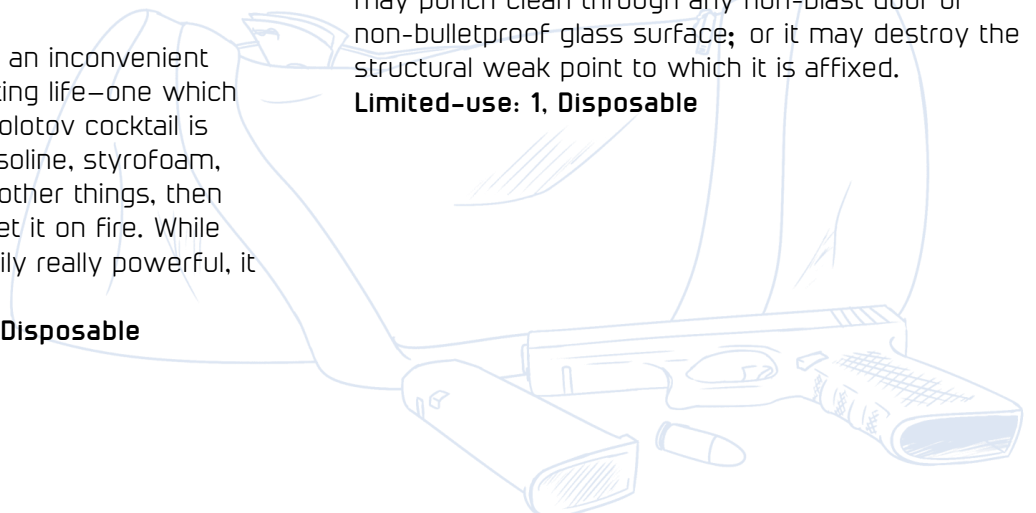

### **Kessler Muni. Katiazucker Trip Mine (\$8000)**

**CAP: 1 | DAM: 6 | RNG: 0 | Equipment | Bomb**

Landmines are nice and all, but they've got their fair share of problems. Chief among those are the fact that some poor fool has to step on them to activate them, which dramatically limits their effectiveness. The Katiazucker Trip Mine doesn't quite entirely negate those problems—mostly because you can't, without it being just as hazardous to you as it is to the enemy—but it *can* mitigate them significantly. Thanks to a complicated IFF (and a military-grade adhesive), the Katiazucker can tell friend from foe, determine precisely when it ought to go off, and stick in dark corners and hard-to-reach areas, to set up the perfect ambush!

The Kessler Munitions Katiazucker Trip Mine will trigger whenever any non-friendly individual passes within 2 squares of it. Beware of collateral damage.

**Blast 3, Pierce: Mesh**

## **Weapon Modifications**

### **S&W FW-21 Compensator (\$20000-WS\*1000)**

**Modification [Barrel]**

The muzzle brake is a simple invention, and the distinctively-christened Fairy Whisper is one of the very best on the market. The Fairy Whisper is a carefully-crafted angular compensator, the most striking feature of which is its prodigious size, which can at first glance make a weapon top-heavy and unbalanced; however, with seven different vents across five different facings, it can redirect the gaseous expulsion of a weapon discharge more effectively than any other muzzle brake on the market. Or in layman's terms, it keeps ya aim from gittin fucked up.

The S&W Fairy Whisper Multi-Vented Compensator can be attached to any weapon which exclusively has the bullet type. While installed, the user can multishot once with the equipped weapon each attack, at no penalty, so long as the target is within half their weapon's effective range, or 8 spaces, whichever is shortest. While it is equipped, you cannot absorb any kind of clash made against you, and roll one fewer dice than normal both to clash and evade enemies with melee-type weapons.

### **LunaSea Sound Suppressor (\$7500-WS\*500)**

**Modification [Barrel]**

While the LunaSea Corporation provides weapons with integrated suppressors for stealth operations, not everybody has the good sense to buy from

them. For those poor dim souls, the LunaSea Corporation has generously provided a suite of standalone flash and sound suppressors, which can be fitted into most modern firearms. While this dramatically reduces the sound and light produced by the weapon, this does decrease the effect of the gunshot itself—which results, tragically, in massively-increased damage falloff.

The LunaSea Sound Suppressor may be fitted onto any one weapon with the “bullet” type. This weapon will gain the “suppressed”, with the additional caveat that it inflicts a -1 damage penalty for every four squares between you and the target.

### **Kessler Munitions Heartseeker (\$10000-WS\*500)**

**Modification [Barrel]**

The Heartseeker Bayonet is a decoratively-named device with a wonderfully simple application: specifically, it's a knife about the size of a gardening shovel, which you affix to the end of your rifle of choice. Then, when the enemy approaches you and attempts to stab you, you stab them instead.

The Kessler Munitions Heartseeker Bayonet can be attached to any long weapon without the melee or throwing types. While it is attached, and you are currently using that weapon, you do not suffer any penalty while clashing against enemies with melee weapons. However, this weapon cannot be held in any item slot other than your Long Weapon slot—which excludes duffel bags, holsters, mechanicles, or anything similar.

### **APSF BM-47 (\$12000-WS\*1000)**

**Modification [Special]**

As much fun as it is to carry large firearms everywhere, they do tend to draw lots of attention. That's bad business for operators who work in crowds or undercover; but fortunately, there's another way. The ever-ingenuous and ever-immoral rat bastards at APSF have, through a combination of high technology and willful ignorance, created a way to take virtually any firearm on the market and load it with enough springs and hinges to make it fully compactable, and thereafter shoved in a briefcase. While this isn't a perfect solution, it's sometimes preferable to just lettin it all hang out.

The APSF Folding Modification and Briefcase can be applied to any long weapon. While equipped, said large weapon loses the dead giveaway trait. However, once you whip it out, it will require some time to erect: you will have to spend two whole actions getting it to full size again.

### **S&W Pathfinder Optic System (\$10000-WS\*250) Modification [Optics]**

Sometimes, you just want to shoot things that are really, really far away. Fortunately, the good people at Snort and Whinny have discovered a way to make this possible. The Snort and Whinny Pathfinder Optic System is a block of sensors, gauges, and readouts all built around a construct of mirrors and lenses. This not only allows you to see targets from a much greater distance, but take accurate measurements of wind and temperature in order to place the most accurate shots possible. Unfortunately, this is quite a bulky apparatus, which makes it difficult to wield in close quarters...

The Pathfinder Optic system can be mounted on any long weapon. This allows you to ignore the penalty that is normally applied to shots made outside of your effective range, up to what would normally be considered your maximum range. However, shots *within* your effective range will suffer a -4 penalty for every third of the weapon's range between your target and the end of your Effective Range. Thus, a weapon with 6 range would suffer a -4 penalty against a target 4 squares away, a -8 against a target 2 squares away, and a whopping -12 against a target 1 square away.

### **TSD Quick-catch Red Dot Sight (\$15000-WS\*250) Modification [Optics]**

Optics is a complicated business by itself, and it is only made more complex by the introduction of firearms to the mix. The ideal rifle sight lens has to accurately highlight the predicted location of a shot, without obscuring the view; and the frame has to be durable enough to survive the wear of combat, but modular enough to be removed and reattached, but also be slight enough to avoid blocking off the shooter's eyeline; and some more complex modern sights even include things like compasses, range markers, or light emitters. Then on the other end of the spectrum, you have the Quick-Catch red dot sight: which consists of a single lens, within which a red dot is painted, which approximates where the bullet will go. It's so easy to use, your grandma can accurately shoot from the hip...right before the recoil breaks it.

Can be attached to any weapon without the melee, throwing, or dookhickey types. When making a reaction shot, if the shot is successful, you may make another one. Other multishot penalties and rulings apply in addition to any already sustained.

### **S&W 21-0 Laser Pointer (\$12500-WS\*500) Modification [Optics]**

The S&W 21-0 laser pointer is a high-powered aiming light which can produce an infrared light beam approximately one millimeter wide—ideal for target tracking in close quarters. The 21-0 is a marksman aid widely seen during civilian and sport shooting, notable most for its bright fluorescent pink light; however, most operators prefer to use the infrared light emitting model that is common among professional operators, for reasons that should be obvious to anyone who's ever aimed a gun at someone and didn't want them knowing.

The laser pointer can be attached to any weapon without the throwing, melee, or doohickey types. Attacks made at a range of 4 squares or less receive a +2 bonus to hit. Attacks made at a range of 6 squares or greater suffer a -2 to hit.

### **CorpTechs ID Tagger (\$5000) Modification [Utility]**

Sometimes, you really don't want people touching your shit. While you can usually get by with a polite request or a nice length of barbed wire, sometimes the would-be stuff-toucher simply will not be deterred by conventional means. The CorpTechs ID tagger is a simple biometric scanner, which comes in many varieties for many uses. In the event that the ID Tagger detects an unauthorized individual, triggers will lock, blades will be dulled, and energy conduits will cease to function. In brief, a CorpTechs ID Tagger prevents people from using your stuff. But more than that, the mounted nanotech interface can also serve as a wi-fi hotspot.

The CorpTechs ID Tagger may be fitted onto any long weapon. While that is your active weapon, it projects a hacking area of influence 5 squares wide around your person. Nobody but you and authorized personnel may use that weapon so long as the ID tagger is equipped; however, it may itself be hacked, denying you use of your weapon.

.45 "Holy Roller" round. Designed to only injure evil people. Did not actually kill its targets, because murder is wrong.

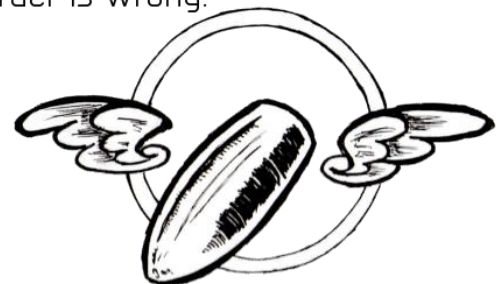

## **Underslung Weapon (\$12000-WS\*200)**

### **Modification [Utility]**

Since the 1700's, people have all had the same problem: they can't carry enough guns. Fortunately, the geniuses at Swhinny, CorpTechs, Thunderbolt, and a dozen other places have all banded together to fix this problem. By use of rivets, interlocking metal rails, and velcro, it is now possible to affix a tinier version of an extant weapon to any long weapon of your choice; which means, of course, that it is possible to get the functionality of two weapons!

When you buy an underslung weapon, you may affix any one of the following weapons to your long weapon. You may affix these to melee weapons if you so desire, but beware of backblast. Underslung weapons do not occupy a slot in your inventory, but you may only take one for each long weapon you are currently carrying.

#### **Shotgun**

**CAP: 1 | DAM: 3 | RNG: 5 | Bullet**

**Shotgun 2, Limited-Use: 2**

#### **Grenade Launcher**

**CAP: 1 | DAM: 5 | RNG 8 | Warhead**

**Blast 1, Limited-Use: 1**

#### **Flamethrower**

**CAP: 1 | DAM: 2 | RNG: 5 | Chemical**

**Burn 2, Cone 2, Limited-Use: 1**

## **S&W Sharpshooter Scope (\$12500-WS\*500)**

### **Modification [Optics]**

The unimaginatively-named Sharpshooter is S&W's premiere mid-range optical mechanism, and it's about as basic as something can get—basic, but effective. This series of lenses sit comfortably inside an impact and weather resistant casing, and make use of a built-in nanite functionality to redraw the crosshairs according to one of sixteen pre-set configurations; and all of this is inside a thin plasteel coating, which keeps it durable without being heavy. A worthwhile addition to any marksman's rifle.

The S&W Sharpshooter Scope can be attached to any weapon with exclusively the bullet type. Attacks made at a range of between 6 and 12 squares gain a +2 bonus to hit. Attacks made at a range of 4 squares or less suffer a -2 to hit.

## **Shoulder Strap (\$7500)**

### **Modification [Utility]**

The Atlas Outfitting Shoulder Strap is as simple as weapon modifications come. It's a padded pleather strap which you affix to the stock of your weapon of choice, and then wrap around your neck. The end result being that the weapon hangs around your neck and shoulders, and when you need it you just pick it up and don't have to fish it out of your saddlebags. Handy little tool for anyone who plans on switching armaments regularly.

The Atlas Outfitting Shoulder Sling can be attached to any long weapon. While the Atlas Outfitting Shoulder Strap is installed, switching to the weapon upon which it is affixed does not incur a penalty. Yes, even the spear. No, you cannot fly if you throw the spear while it has a shoulder strap.

## **Kapricorn Duelist's Magnegarde (\$12500-WS\*600)**

### **Modification [Utility]**

The duelist's magnegarde is a simple but valuable modification compatible with most forms of close-quarters weapon. Consisting entirely of some insulated wire, two bars of nickel, some L-braces, and a small battery, the Magnegarde is a low-yield electromagnetic array which can be affixed to a haft, a blade, or even a gauntlet; and thereafter powered for a very brief period. This can be used to sharply yank incoming swords, axes, or what-have-you, with enough force to throw off the aim of the person wielding them. Unfortunately due to the small size of the battery—a requisite for maintaining the balance of the weapon, unfortunately—this can only be activated for about half a second at a time, making it effective only at distracting, but not disarming.

The Kapricorn Duelist's Magnegarde can be affixed to any weapon with the melee type. While a weapon with the Kapricorn Duelist's Magnegarde is equipped, you may force any attack made against you with a melee-type weapon to be treated as a clash.

.45 "Pocket Satan" round.  
Designed to only harm law  
officers. Did not actually  
discharge, because  
it did not want to  
be helpful.

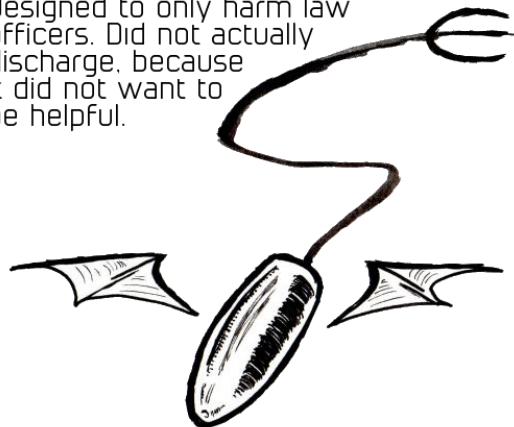

## Alternate Ammunition

### Bodkin Arrows (\$12500)

**CAP: == | DAM: -1 | RNG: -3 | Ammunition**

**Compatible with any weapon that fires arrows.**

As much fun as arrows are, they have a rather alarming tendency to splinter and fall apart as soon as they hit something too hard for them to piece; or, if you're using one of the more modern steel arrows, they just sorta brush awkwardly against their targets and fall off. This means that most arrows are ineffective against armored targets. However, there are a large number of less-than-legitimate craftsmen willing to use their no-good know-how to fit your arrows with a high frequency tip—which can make them cut right through ceramics, at the cost of flight distance and stopping power.

**Limited-use 8, Pierce: Ceramic**

### Poison Arrows (\$7500)

**CAP: == | DAM: -3 | RNG: == | Ammunition**

**Compatible with any weapon that fires arrows.**

It's an arrow, ya stick it in poison, this shit ain't difficult.

**Limited-use 8, Poison 4**

### Knockout Arrows (\$10000)

**CAP: == | DAM: 0 | RNG: == | Ammunition**

**Compatible with any weapon that fires arrows.**

Calling these "arrows" is something of a misnomer. The APSF knockout arrows are actually small hobnail-sized nanotech darts, which are capable of delivering a powerful neurotoxin to the bloodstream and then dissipating an instant later, leaving its victim with the impression of a particularly vicious bug bite. Unfortunately, the small size of the dart means it trends towards inaccuracy, and suffers from a tremendous dearth of stopping power. Moreover, the poison used in most of these darts is countered if the target gets even the slightest rush of adrenaline after first contact is made—meaning it will cease to be effective as soon as you are seen.

Knockout arrows are ineffective against robotic targets.

**Assassin 3, Poison 3, Limited-use 8, Nonlethal**

### Hollow Point Rounds (\$15000)

**CAP: == | DAM: +4/-2 | RNG: -4 | Ammunition**

**Compatible with any weapon that fires bullets and does not have the "shotgun" trait.**

Ah, hollow point rounds. Despite being the most widely-known kind of specialized ammunition, it's also one of the most tightly-regulated: hollow point rounds are considered a violation of the Wasteland accords and are only authorized for use for home defense and pest control. This is because the all-important hollow point—causes them to expand on impact and do very nasty things to your internal organs.

Hollow point rounds only receive their +4 damage bonus when attacking unarmored targets. Otherwise they suffer from the -2 penalty.

**Pierce: Mesh**

### Beanbag Shells (\$12500)

**CAP: == | DAM: -2 | RNG: ==**

**Compatible with any weapon that has the "shotgun" trait and the "bullet" type.**

Sometime in the 20<sup>th</sup> century, security innovators ran into a problem: everyone likes using shotguns, but sometimes you want to shoot somebody with a shotgun without killing them! This made many policemen and prison guards across the country very sad—but fortunately, a solution presented itself! Instead of loading a shotshell with bullets, you can just load it with tiny bags filled with little rubber ball-bearings!

**Nonlethal**

### Armor-Piercing Rounds (\$2500 PER BULLET)

**CAP: == | DAM: -2 | RNG: -4 | Ammunition**

**Compatible with any weapon that fires bullets and does not have the "shotgun" trait.**

Problem: sometimes people wear ceramic armor.

Solution: build bigger bullets.

**Pierce: Ceramic**

### Tartarus Armaments Space-saving Arrows (\$5000)

**CAP: +5 | DAM: == | RNG: -2 | Ammo**

**Compatible with any weapon that fires arrows.**

The Tartarus company's Space-saving arrows are basically smaller versions of regular arrows, which sacrifice head weight and fletching quality in exchange for being very, very, thin. This allows them to be loaded into "magazines", which can in turn be loaded into crossbows—thusly creating that coveted semi-automatic crossbow action.

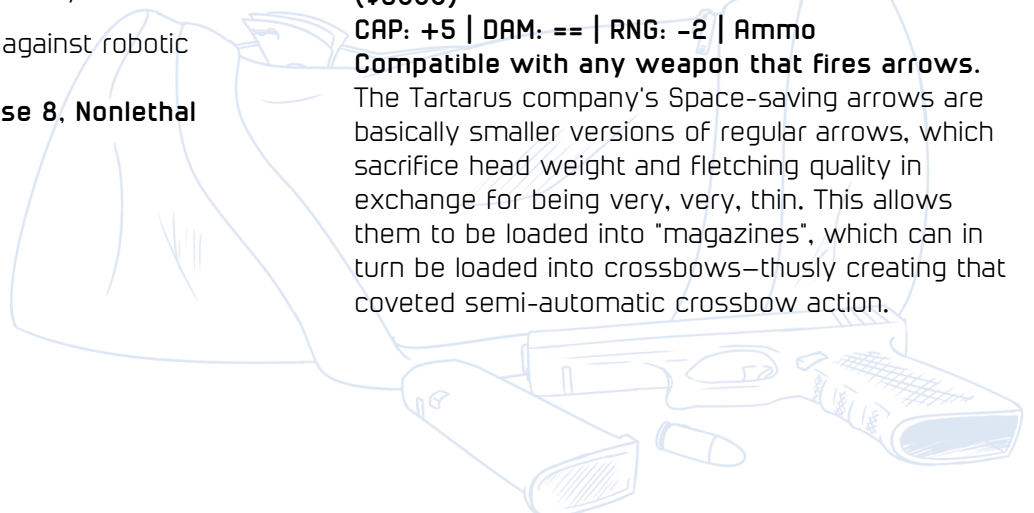



**Tartarus Armaments Shatterbolt Arrows (\$7500)**

**CAP: == | DAM: -1 | RNG: -2 | Ammo**

**Compatible with any weapon that fires arrows.**

While Tartarus chiefly manufactures weapons of the monster-slaying variety, they were eventually forced to contend with an unpleasant reality about their clients' area of operations: there's a lot of fucking bandits out there. So, they crapped out these little dandies: arrows that are meant to, on contact, shatter into a bunch of jagged pieces. While these are *technically* illegal under the Wasteland Accords, Tartarus has enough pull to get the STC to pretend it's a bunch of convenient manufacturing errors whenever someone complains.

**Shotgun 3, Bleed 3**

**Frag Rounds (\$10000)**

**CAP: -5 | DAM: -2 | RNG: ==**

**Compatible with any weapon that fires bullets.**

Don't get too excited, kids. These little nitro-tipped beauties don't turn your bullets into miniature bazookas. All it does is cause the bullet to fragment into a bunch of little lead shards that damage surrounding enemies. Use these to take care of clustered-up targets or dominate close quarters.

**Blast 2, Pierce: Mesh, Disposable**

**EMP Shells (\$12500)**

**CAP: == | DAM: 0 | RNG: == | Ammo**

**Compatible with any weapon that fires bullets.**

It's well and good and all to have explosive shells, and incendiary shells, and whatever-the-hell-else you young people load into your guns; but sometimes the only way to really give a fuck-you to technology is with a rubber shell loaded with a single high-voltage battery! While WHEE have no idea how this thing works, we know what it does: if this thing hits an aug, it will fuck them UP.

**EMP 1**

**Apocalypse Rounds (\$10000 PER BULLET)**

**CAP: == | DAM: +4 | RNG: == | Ammo**

**Compatible with any weapon that fires bullets.**

Now these DO turn your bullets into miniature bazooka rounds. Armor-piercing heads, high explosive filling, and an incendiary chaser—these bullets cost more money than most people make in a month, but ho-lee SHIT will they leave a mark on whatever they hit.

**Pierce: Plasteel, Blast 2, Burn 5, Disposable**

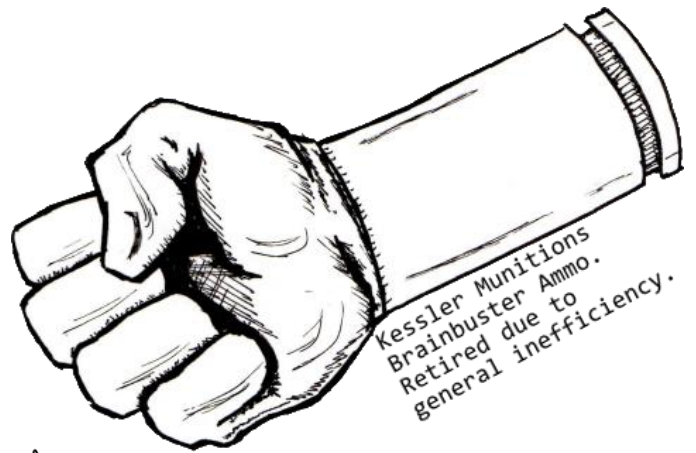

Pharminos Combat Syringe. Used to administer antidote to victims of dangerous transformative substance.

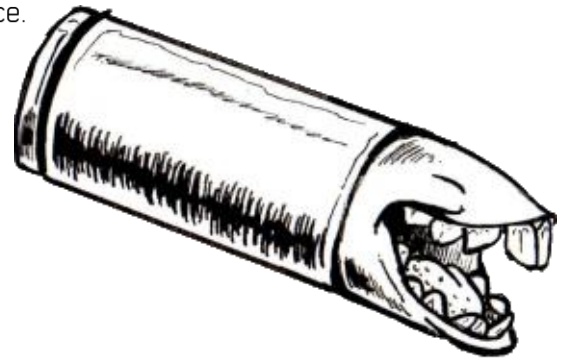

Corptechs bucktooth shot. Retired for obvious reasons.

ASPF Soulswallower round. Prohibitively expensive due to trade restrictions on eldritch visions from the darkest pits of planet Hell.



## Augmentation of all Distinction

### Global Augments: Put em Everywhere!

#### OuchEaze Little Helpers (\$500)

##### Subdermal, Global

With the ability to seal cuts and dull pains, the OuchEaze little helpers is the perfect injection for athletes young and old alike! It's used in hundreds of schools and sports clubs all across the world—it's affordable, non-invasive, and can be bought at most major pharmacies.

The OuchEaze little helpers increase your maximum health by 1 point. This effect will persist even after your health has been reduced by a third.

#### Divinity Systems Nanoskin (\$20000)

##### External, Global

Divinity Systems is more than a company: it is a statement, that technology and its users can be one in the same. With the safe and revolutionary nanoskin surgery, it is possible to implant a cluster of negliphagic nanobots within a patient which can leverage your natural healing ability to intelligently diagnose and repair damaged augments, computers, and other small electronics in a matter of minutes. Buy yours today, and become one with the world around you.

Once per job while the Divinity Systems Nanoskin is installed, you may spend a power burst, and instantly restore your armor and shields to their maximum level. However, doing so will give your armor the "Dead Giveaway" trait for the rest of the job, and make it irremovable unless you voluntarily take 5+1d3 damage.

#### Technicular Dreamcoat (\$20000)

##### External, Global

From our ultrahighdefiperfectoscopic cameras to our shimmerscreen television, the Technicular Corporation has redefined image transmission—and now, we're redefining refraction. This one-of-a-kind vanity augment uses a brilliantly crafted network of cameras and nanobots to capture and replicate dazzling okay yeah you know what this marketing blurb is so up its own asshole we're not reprinting anymore of it. Point is, this is a shitty but affordable and man-portable version of some optic camo thing they put on tanks, stick it in your skin and you can be all like a chameleon man woosh. It ain't perfect but it'll do in a pinch.

While it is installed, you may activate the Technicular Dreamcoat at any point, so long as you are lying on the ground. You then become untargetable and invisible to the naked eye, so long as you do not take any other actions than moving at crawl speed (SEE: Sneaking II: Earshot and Sneaking Techniques), and do not close within 5 tiles of an enemy. *However*, this is only effective against targets currently occupied in a combat engagement, making it ineffective as an infiltration tool and ideal only for avoiding fire. You may not engage the Technicular Dreamcoat while an enemy has unobstructed line of sight to you, or on the same turn you take another action.

### Special Augments: Put Em Elsewhere!

#### Mercury Messaging Comm System (\$2000)

##### Subdermal, Special: Jaw.

You need this. This, right here, is possibly the single most important augment an Operator can get. It's a simple implant right under your tongue and your ear, controlled via a wrist mount, and it's gonna save your life more times than you can count. What it does is, it allows you to create chat rooms with other people in a localized area, and have a digitally-amplified conversation. What that means is you can whisper to one another from across an entire city block, and hear one another like you're right next to each other. If you're part of a crew, pick this up and never let it go.

The Mercury Messaging Comm System allows you to have conversations with your teammates from anywhere on the map. Presume its effective range to be about 200 city blocks.

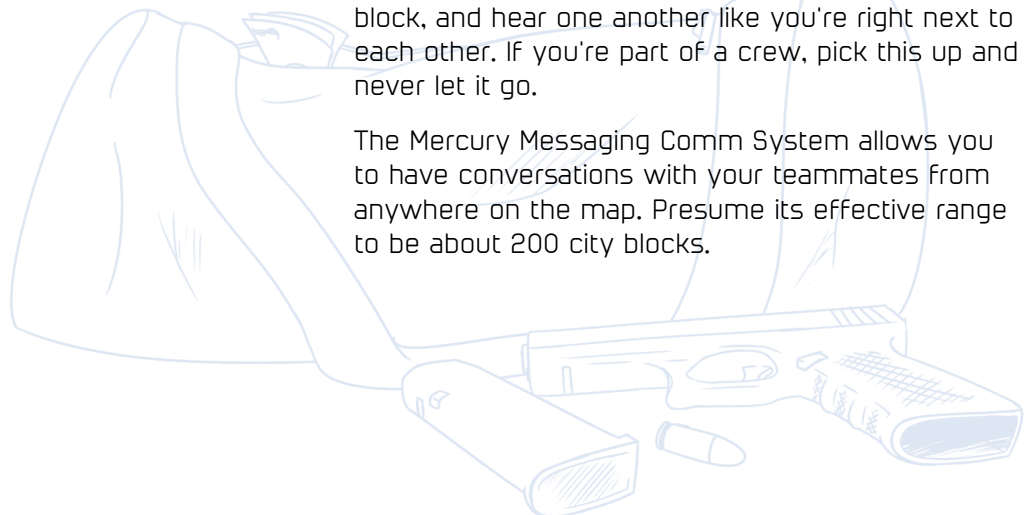

### **Cyberweapon Mount (\$2500)**

#### **External, Special: Weapon Mount**

One of the most popular and enduring ideas in the history of commercial augmentation is the “cyber-weapon”: a weapon (usually a machine gun) which can be implanted in the wrist of an augmented individual and thereafter extended on command. The most common of these usually involves some kind of retractable cradle which runs parallel to the wrist, or a series of moving parts that allow the end of the limb to drop down, split apart, or otherwise move out of the way to admit the weapon. Cyberweapons are generally frowned upon by soldiers: their installation requires several major surgeries; they are generally less accurate and nimble than other guns; and their usage intrudes upon an otherwise fully functional hand. However, despite this, they remain popular among low-class operators due to their distinctive aesthetic and incredible concealability.

When you purchase the cyberweapon mount, you must purchase a single short or long weapon simultaneously, this weapon is denoted as a 'cyberweapon'. You may own as many cyberweapons as you wish, but may only bring one with you to any job. They do not occupy spaces in your inventory, lose the Dead Giveaway trait, and do not affect suspicious person rolls. Cyberweapons become inoperable if you are damaged by EMPs.

### **Featherfall Contact Parachute (\$7500)**

#### **External, Special: Shoulderblades**

Hiking is a great and dangerous sport. No other hobby claims as many lives each year. Olympus Sporting goods is thus proud to present the Featherfall Contact Parachute: the one-of-a-kind augment that will make sure you're never in harm's way again. Mounted on your spinal column and on each of your wrists, the Featherfall contact parachute uses a net of speedometers and vital monitors to calculate your current condition—and the very instant you reach 1/3 of terminal velocity, the FCP releases a mist of nanomachines which encase you in a shell that's hard on the outside, but soft and gelatinous on the inside. Any fall, no matter how long, can be cut down to just a few pounds of force—which means that you never need to be afraid of heights again.

The Featherfall Contact Parachute allows you to survive any fall, albeit taking 1d3 damage if it was 40 squares or longer. It can only be deployed once per mission.

### **Skull Augments: Skullcaps and Skullguns**

#### **Divinity Systems Micromagnetic Disturbance Detector (\$12500)**

##### **Subdermal, Skull**

Divinity Systems has always held that information, of all kinds, is of paramount importance: particularly when that information is “the location of someone who is actively trying to murder you”. In the modern day, there are a great many ways of concealing that information, from conventional camouflage to complex magic. However, while you can hide somebody's body, it is impossible to disguise the micromagnetic fields emitted by inky bodies—and it is only very slightly easier to see them. The DivSys Micromagnetic Disturbance Detector is an incredibly powerful magnetometer, which can register all magnetic fields within a very limited radius around it—and it will note the inky ones, and tell you where they are.

While you have the Divinity Systems Micromagnetic Disturbance Detector installed, you gain extrasense up to 2 squares.

#### **APSF Eyespy Ocular Enhancement Unit (\$25000)**

##### **Subdermal, Skull**

The only way to blow a stealth mission is to get caught, and the easiest way to get caught is to get seen. Every infiltrator in the world knows how much easier their job would be if they could accurately see exactly where their targets are looking at all times; and the mad geniuses at APSF, bless their twisted blackened souls, have just the thing to let you do that. The Eyespy Ocular Enhancement unit is a finely-tuned camera eye, and—this is the important part—a subscription and a channel to an APSF-maintained database of known law enforcement and gang-affiliated individuals in the Doubleearth, and their visual testing scores and known augments. If the Eyespy is pointed at one of those people, it fetches the information from the database, and then cross-references this information with user-defined parameters for weather and light levels, and—through the magic of computing—creates a real-time augmented reality overlay which approximates and highlights their field of view. Or, to put it simply:

The APSF Eyespy Ocular Enhancement Unit allows you to see the exact length, breadth, and facing of enemy lines of sight so long as you have not moved for one turn, and can make uninterrupted eye contact with them. Moving dispels this effect.

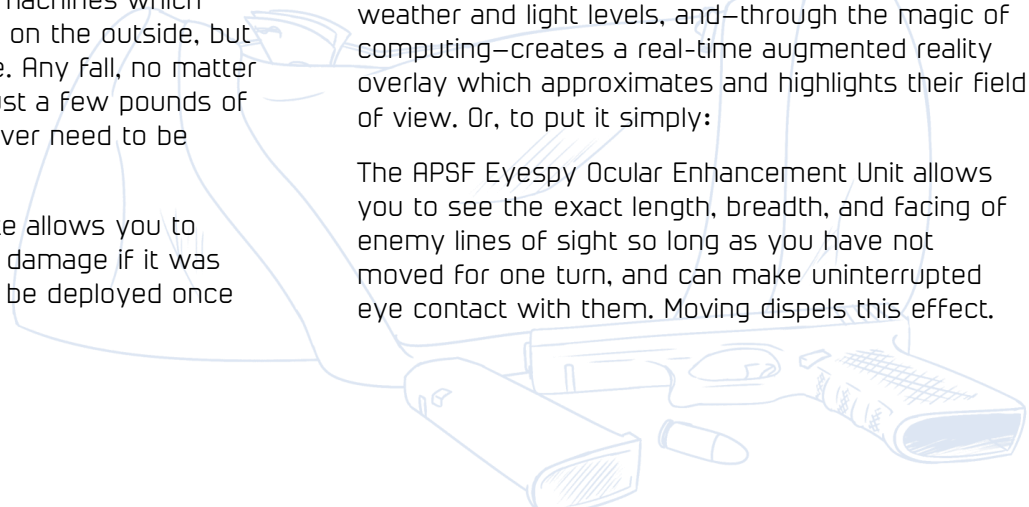

## **AMind Radio System (\$1000)**

### **Subdermal, Skull**

Are you tired of the noise of the city, the hustle and bustle of the office, and the annoying pop songs on the loudspeakers? With the AMind radio system, invasive pop tunes become a thing of the past! With a simple wrist-mounted touchscreen and a non-obtrusive implant, you can tune into your favorite AM radio station, and have it play directly into your ear!

The AMind Radio System can pick up radio signals. While it is installed, the GM must notify you of enemy wireless communications if you ask them to

## **Atlas Outfitting Cranial Plate (\$50000)**

### **External, Skull**

In a gunfight, the only bullet that really matters is the one that kills you. With the Atlas Outfitting Cranial Plate augment, you can make it take just a little bit longer for you to meet “the one”. It’s a simple augment, with a complex surgery: the cranial plate is a millimeter-thick sheet of plasteel, which is mounted inside the skull and anchored into place by a number of small bolts. This means that if you are shot in the head, you will suffer traumatic skull damage and one hell of a headache, but your brain will just get shaken around instead of torn apart. Long-term hazards of the cranial plate include cerebral bruising, hemorrhaging, and liquefaction. But the short term hazards no longer include death.

Once per encounter, if you would be incapacitated by an attack, ignore the damage dealt by that attack, and instead lose an action on your next turn.

## **Peeping Tim (\$12500)**

### **Subdermal, Skull**

Are you blind? Do you need glasses? Are you sick and tired of jamming contact lenses into your eyeballs everyday and pretending it doesn’t hurt? Fortunately, for those of you who don’t mind a quick and affordable surgery, there’s a new and better option: Peeping Tim is the cutting-edge future of affordable and effective ocular enhancement in the home. Capable of supplanting and augmenting biological eyes with unerring precision, the Peeping Tim will help you read tiny letters, recognize strangers from a distance without awkwardly hailing them because you think they’re someone you know, and finally find Waldo. Ask about our “Eyes in a jar” memorabilia option, available at participating hospitals

While you have the Peeping Tim installed, your sight sense increases by 3 squares.

## **CorpTechs Delphi Targeting Augment (\$15000)**

### **External, Skull**

Let’s face it: no matter how good a marksman you are, leading a target is hard. Enemies move fast and unpredictably, and half the time they’re shooting back! Fortunately, CorpTechs is there to help, with the award-winning Delphi-Pattern Predictive Targeting Augment! Using a patented motion detection software, the Delphi can recognize and predict enemy fields of movement, and then provide a ballistic analysis of any compatible weapon, before projecting a simple and distinctive AR reticule to highlight the ideal target zone—even in winds, heavy rain, high speeds, or sustained automatic fire. If you’re in mercenary, police, or military work, get yours today, and never miss an important shot again!\*

While the CorpTechs Delphi Targeting Augment is installed, the penalty to reaction shots is reduced by 2.

\*unless you just kind of suck

## **Peeping Tim Micro (\$7500)**

### **External, Skull**

The Peeping Tim Micro is a nano-machine hub no larger than a nickel, which can be implanted behind the left temple via a cheap surgery, of the kind covered by the majority of health care programs. Through a combination of nano-mechanical lenses and advanced pattern recognition software, the Peeping Tim Micro is capable of passively recognizing, highlighting, detailing, and enhancing a wide variety of substances, wear/tear patterns, and more. Whether you’re a doctor needing to analyze a patient’s organs at a glance, or a recent widow trying to clean her carpet, the Peeping Tim Mico can help you see the world in all its gory detail.

While you have the Peeping Tim Micro installed, you can see places where people have recently or regularly walked—as in the case of guard patrols, following the trail of a suspicious person, etc etc. You may also roll perception to notice substances which may otherwise have gone unnoticed.

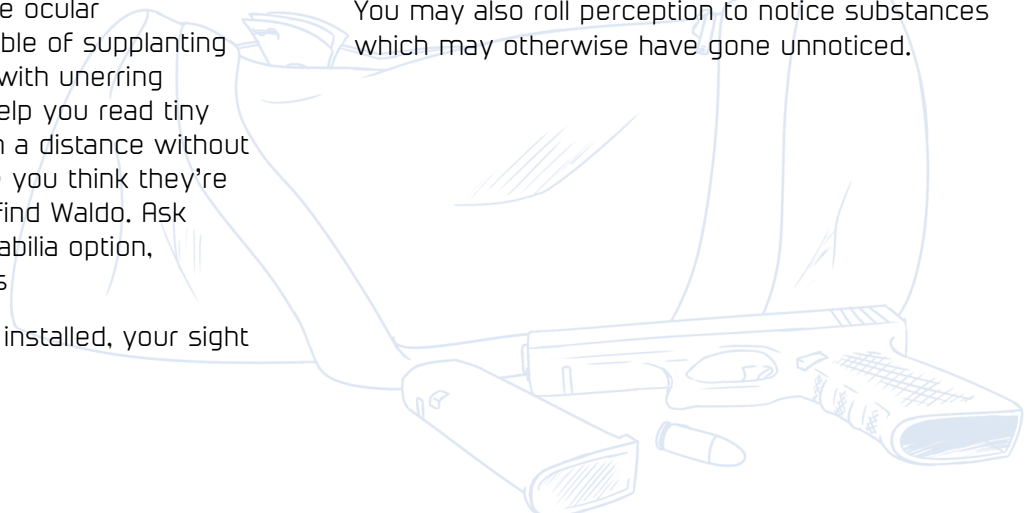

## Neck Augments: Rubbernecks, Roughnecks

### Divinity Systems Neural Regulator (\$5000)

#### Subdermal, Neck

Fear is the great bane of mankind. Since we first became aware of our own weakness, fear has plagued each and every person on the planet. Now, after thousands of years, Divinity Systems has found a way to rid mankind of fear once and for all. The DivSys neural regulator is a chemical "railroad switch", which can—after reaching a certain threshold—abruptly cut off and counter the development of fear reflexes, without compromising survival instinct. If you're living with chronic anxiety, Post Traumatic Stress Disorder, or hallucinations, ask your doctor if the DivSys Neural Regulator is right for you.

The Divinity Systems Neural Regulator allows you to ignore one point of any penalties inflicted by fear effects, and grants a +2 bonus to grit rolls made to dispel any extant fear effects.

### Divinity Systems Neural Uplink (\$15000)

#### Subdermal, Neck

Every so often you find a piece of equipment that's just too complicated to be operated with the tools that mother nature gave you. While luxury and convenience gave birth to the Technological Ascender, necessity was the mother of the Uplink Spine. With the advent of technology such as the Mechanical skeleton, it became necessary to perfect 1:1 motion synchronization between devices and pilots with minimum neural backlash. Thus, the DivSys Neural Uplink Spine was created. Implanted within the backbone, the Uplink Spine—Or "the shark fin", as it is sometimes called—manifests itself as a small metallic protrusion on the back, which is plugged into the target device. Unlike the Technological Ascender, it only interfaces with a few pieces of technology—but it doesn't quite have the debilitating mental effects of its more versatile counterpart.

The Divinity Systems Neural Uplink Spine grants you Uplink(0) 2. After installing the DivSys Neural Uplink Spine, you take 3 additional damage when your currently-equipped armor breaks, in addition to any other damage you would normally take that turn.

### Olympus Sporting Goods Vertebral Reinforcement Augment (\$20000)

#### Subdermal, Neck

In all forms of close combat, whether it be for sport or with the actual intention of killing, there has long been a common sense rule: aim for the head. We, the fine people of Olympus, feel no need to explain why punching someone in the head and throat is a good idea, but we *are* perfectly willing to tell you what you can do to keep it from happening: with our vertebral reinforcement augment, something that could be the end of you can become just a slap on the back.

While the Olympus Sporting Goods Vertebral Reinforcement Augment is installed, you have complete immunity to cold-cock or decapitation clash results: in the event that somebody should use as much against you, it will be treated as "clash continues" instead. An opponent may still choose to take an effect from lower on the clash table.

### Divinity Systems Technological Ascender (\$25000)

#### Subdermal, Neck

The DivSys TA is one of the most dangerous and tightly-regulated augments on the market. It installs a suite of I/O ports on the back of your neck, which connect straight through your spine and into your nervous system via a number of mecha-neurons. This means you can directly access, and interface with, any piece of technology on the market—right inside your head, with no screens. However, TA installs are prone to rejection, disease, neural scarring; and behavioral side effects can include nightmares, fugue states, nervous tics, speech impediment, hallucinations, and who knows what else. Getting a legal install of one of these requires a triple-certification, and will put you on meds for the rest of your life. Maybe it's worth it.

The DivSys TA gives you a +4 bonus to all hacking or hardware rolls you make to use Computers or Targeting Software weapons in your possession. This bonus can be conferred to any piece of technology meeting these criteria you find in the field, albeit with a 1d3 damage penalty every time you connect to something. Your technological ascender counts as an allied hardpoint; and if it is hacked, it ceases to function, no longer counts as a hardpoint, and then you will **instantly be incapacitated**. You may, however, be revived as normal. The technological ascender begins functioning normally upon the start of your next job.

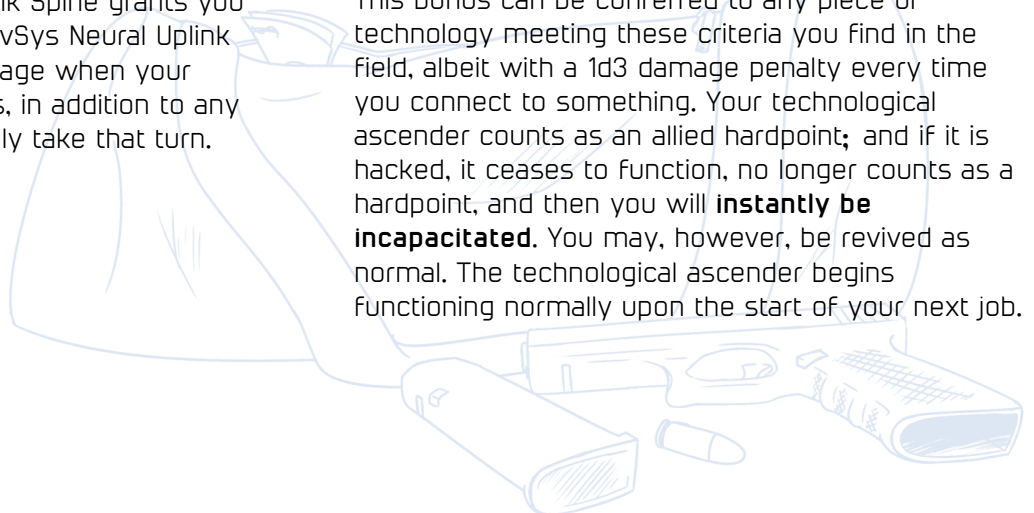

## **Chest Augments: Not That Kind**

### **Olympus Sporting Goods Healrite (\$40000)**

#### **Chest, Subdermal**

Are you battered, bruised, or out of breath? If you live the active and often-dangerous life of a wilderness sportsman, the answer is often yes. That's why Olympus Sporting Goods created the Healrite Cardiac implant. When it detects intense physical stress, a Healrite implant releases a cloud of healing nanites, which can improve bloodflow, rapidly oxygenate red blood cells, and speed the growth of platelettes over dermal rupture—allowing you to get back in the game, and keep on keepin' on.

While the Olympus Sporting Goods Healrite is installed, you heal your full grit score instead of half grit when you heal between encounters.

### **Divinity Systems Faraday Plate (\$20000)**

#### **Chest, External**

The eternal bane of the Augmentician is the Electromagnetic Pulse: a phenomenon of nature which can lay even the mightiest of cyborgs low—even moreso when it's weaponized by those who would pin down and restrain your own hard-earned potential. But no more. With the Divinity Systems Faraday Plate, you can create and carry your own lightweight EMP-resistant environment, to guard against the weather and everything else.

While the Divinity Systems Faraday Plate is installed, you may reduce all instances of EMP damage done to you to half-strength, rounding up. Additionally, whenever you are hit by an EMP, you may pick any currently-installed augment; it will not be affected by it. The Faraday Plate cannot, itself, be disabled by EMP attacks.

### **Atlas Outfitting Titanio Body Shield (\$50000)**

#### **Chest, External**

Armor: the principle attire of the soldier, bodyguard, militiaman, and more. But its presence can betray you—it can weigh you down or make you stick out, and that can spell disaster. But there is another way: with the Atlas Outfitting Titanio Body Shield, your very skin can become a suit of armor all by itself, thanks to a minimally-intrusive set of retractable dodecamolecular Plasteel grafts, which can take form in a single instant, and fold away just as quickly. This can protect center mass with no noticeable effect on your movements or abilities. That can stop a bullet. That can save a life, and not just yours.

While the Atlas Outfitting Titanio Body Shield is installed, your character gains Invulnerable 2. While the Atlas Outfitting Titanio Body Shield is installed, your maximum Power Burst capacity is reduced by 1.

### **OuchEase Emergency Cardiostaiblizer (\$35000)**

#### **Chest, Subdermal**

Oh no! You've cut yourself! You've touched an electric fence! You've had the wind knocked clear out of you! But not to worry—no matter how deep your cut is, or how bad the pain might sting, the OuchEase Emergency Cardiostablizer will be there. Using a microdefibrillation implant, the OuchEase EC can instantly detect and restore skips in any sapient heartrate—mitigating the effects of shock, blood loss, and more...

If you are incapacitated while the OuchEase Emergency Cardiostabilizer is installed, you are instantly stabilized. Once per encounter you may overclock the OuchEase Emergency Cardiostabilizer. If you choose to do so, roll grit at a -4 penalty. If you succeed, you instantly revive with one third of your health restored. However, after overclocking it, you will not benefit from its instantaneous stabilization properties for the rest of the encounter; and you may not heal any higher than that amount for the rest of the job under any circumstances.

### **DivSys Digistructor Platform (\$50000)**

#### **Chest, Subdermal**

Smuggling isn't easy, and that's just a fact. If you get something past the guards, you have to get it past the scanners, and then the sniffer dogs, and then the artist if you're in that kind of place. The sad truth of smuggling anything is that the only place you can reliably hide your contraband is waaaaaay up your buttole; and sometimes, they have a machine for that, too! But there's one thing no scanner can get past, and that's a digistructor platform. This dandy little augment is a gelatinous semi-mobile sac, implanted immediately behind the sternum, which is itself split in two, and patched up with a porous nano-mesh. The sac is host to a colony of easily-maintained nanobots, which can "eat" any inorganic material it is presented with—breaking it down to the molecular level, and then storing it inside the sac. The colony will then, upon command, reassemble the item, using itself as a bonding agent. What this means, in layman's terms, is that you can shove a whole gun inside your chest, and then yank it out whenever it's convenient.

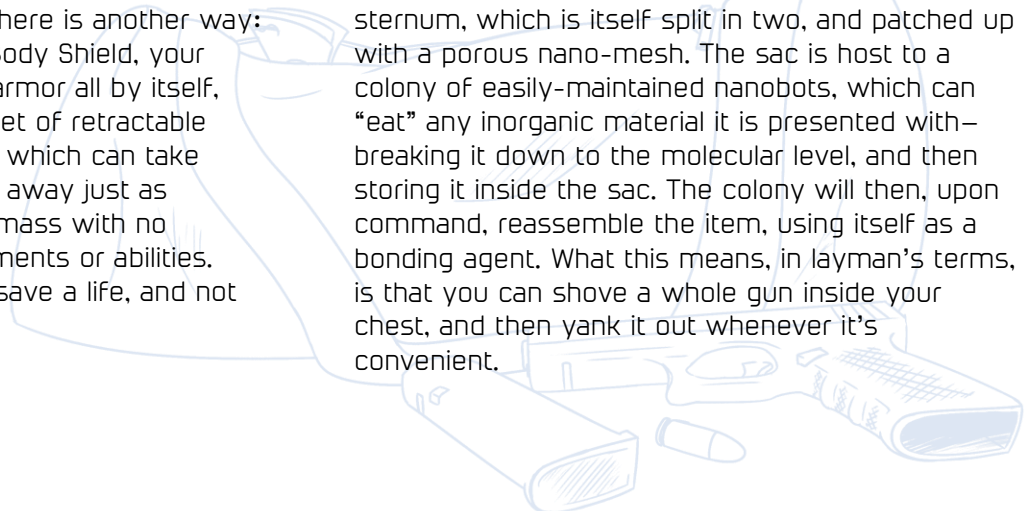

When you have the DivSys Digistructor Platform installed, designate a single weapon or piece of equipment in your inventory. It is then stored inside your torso, and as such no longer takes up inventory space, and is undetectable by any means: presume that all metallic or magnetic detectors mistake a stored item for some kind of respiratory or cardiovascular implant. While an item is stored inside you, it cannot be removed involuntarily; and if you should come under the effects of an EMP, it cannot be removed until the Digistructor platform is repaired. It takes two actions to remove an item from inside you.

## **Back Augments: Not Just Braces**

### **CorpTechs Hexagon 2 Shielding Unit (\$10000)**

#### **Subdermal, Back**

#### **SHD: 4**

Impact, filth, high winds—all of these and more are just part of country life. But what if they didn't have to be? The CorpTechs Company is proud to present the latest advancement in personal shielding augmentation, reverse-engineered from the very same technology used by our armed forces. With a simple non-invasive augment, you can shield yourself from the little things—and those are the ones that count.

The CorpTechs Hexagon 2 Personal Shielding unit is a complex-but-small augment that projects a thin energy shield around its owner. While it was intended to keep out dirt and small force impacts, it is *just* strong enough to hold off a single small-caliber bullet. Definitely a good buy.

### **Apogee Satana Instant Armor (\$1500)**

#### **Subdermal, Back**

We here at Apogee Satana must regretfully inform you that Instant Armor is something of a misnomer—your armor will take between six and thirty-six seconds to arrive, on average. That being said, this is a mere six seconds to do what you normally need a minute—and if you are deep enough in the business to be reading this text, you know how important that is. Using a state-of-the-art system of transponders, latches, and booster rockets, our brilliantly-minded scientists can convert any suit of weapons and armor into a peerlessly nimble and responsive self-propelled package, which is capable of guiding itself through enclosed terrain and onto your body in a matter of seconds, with only minimal concussive trauma. Invest in Apogee Satana, and never go without your second skin.

Okay so ya know that cool self-guiding armor Iron Man had in the Avengers yeah this is pretty much that. And if you never saw the Avengers, what this means is that your armor can be stored anywhere, and then be guided towards you by booster rocket and assembled on your person by the same It takes X turns to arrive, where X increases by 1 for every 20 spaces between you and it. Also unless you use an action to brace yourself for impact on the turn before it arrives, you take 1d3 damage when it hits you. Slap it on any weapon or item you want, costs 1500 per.

### **Divinity Systems Mechanicles (\$12500)**

#### **External, Back**

Technology is a medium by which mortals may transcend inconvenient realities: and with the Divinity Systems Mechanicle Augmentation System, you can at last overcome the longstanding mortal obstacle of only having four limbs. Compatible with most neural uplink augments, the Mechanicle Augmentation System allows any sapient species to effortlessly and safely control up to four mechanical limbs—each of which responds just as fluidly and naturally as any other.

The Divinity Systems Mechanicles set is an augmentation which can be modified between missions to provide a number of different functions. Most of these modifications must be purchased individually, and all of them are listed below. Most mods require at least one of the mechanicles to use, and this cost is listed in their description. A mechanicle which is already serving a function may not be used for another. You may never have a combination of functions which requires more than four mechanicles to use.

The default Mechanicles package comes with four Mechanicles. A Divinity Systems Mechanicle Augmentation System cannot be hidden by duster coats or other clothes. While you have the Divinity Systems Mechanicle Augmentation System installed, you no longer gain free power bursts at the end of jobs.

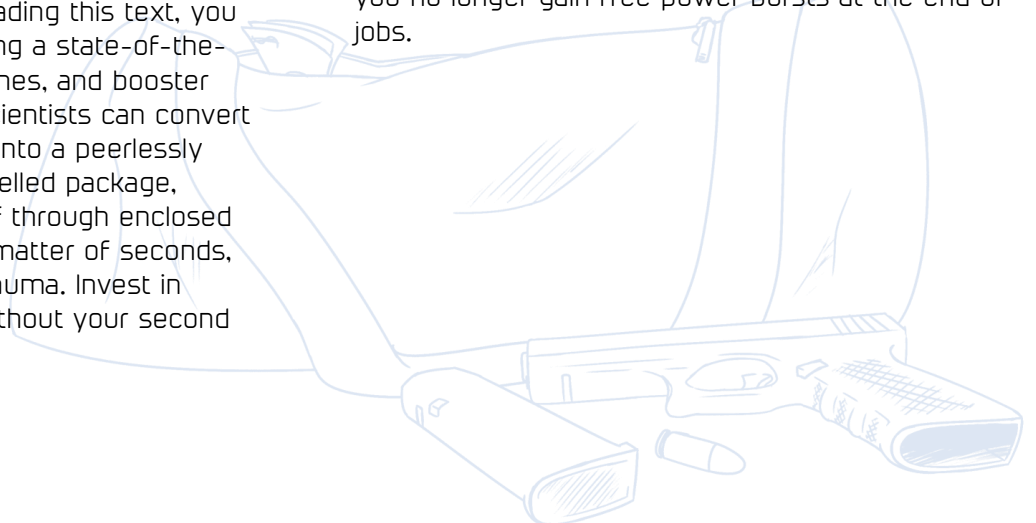

## **Mechanics: They Get Their Own Section**

### **Pipsqueak Pliers (Included With Purchase of Divinity Systems Mechanics)**

#### **Requires one Mechanicle**

About as wide as a baguette, and capable of expressing force comparable to a jaw, a Pipsqueak Plier is the first mechanicle function most recipients learn to use. While it lacks strength, it compensates with flexibility: it can be used to pick up and manipulate objects. Sadly, however, it cannot actually use whatever it is carrying, due to its limited dexterity. This makes it good for little other than pack mule duty, or else as a cupholder while you're doing something with your real limbs. However, the the Pipsqueak Pliers are the only commonly-available Mechanicle function suited for heavy loads—which means despite its limited functionality, they're the only arms which will be good for carrying loot.

For every Pipsqueak Plier you currently have equipped, you can carry an extra duffel bag, regardless of its contents.

### **Normalizing Necktie (\$1500)**

#### **Does not require any Mechanicles**

For those of you who'd rather not wear your colors (and/or nefarious intentions) on your sleeve, Divinity Systems has another answer: the normalizing necktie. For a nominal fee, this simple adapter-cum-power-source—which is to the naked eye indistinguishable from a collar, choker, or tie—allows you to power and operate a set of Mechanicles without the painful and disfiguring implant process. This allows you to fold up your Mechanicles and take them with you wherever you go, and only put them on when you need them! Unfortunately, this severely inhibits your ability to uplink with anything else, due to the complex nature and severe demands of the adapter.

It takes four actions to don a set of Mechanicles once battle has been joined. While folded up, a set of Mechanicles cannot be used for any reason. While attached, they function normally.

### **Retractable (\$1500)**

#### **Does not require any Mechanicles**

For those of you who want the concealment factors of a Necktie without the hassle of assembling it each and every time, there is an answer: the Retractable function! For an equally nominal fee, your Mechanicles can be modified with a retracting function, which allows them to retreat into your chest cavity at any moment with but a thought! Unfortunately, due to the troubled relationship between steel and vital organs, you inevitably need a second man on hand to make sure things go well.

While wearing a set of Retractable, you may retract whatever Mechanicles you have installed (regardless of their installed function), which makes them undetectable (as defined in the "Weapon traits" section of 6A: Nerd Edition), and concealable by clothing. However, whenever you do this, another crew member of your choice must make a hardware roll, with a stacking -1 penalty being applied for every map tile between you and them. If they fail this roll, you will instantly take 1d3 damage, which cannot be blocked by shields or armor. If they critically fail this roll, or if no-one makes the roll at all, you will instantly be incapacitated, and shortly thereafter suffer a horrifying death by internal hemorrhaging if you are left untreated.

### **Long Weapon Mount (\$3000)**

#### **Requires two Mechanicles**

And here, we finally arrive at one of the proverbial big earners—one of the biggest, if not the biggest reasons Operators invest in Mechanicles. By using one arm to aim and another to absorb the recoil, it's possible to convert half a set of Mechanicles into a pretty-much-flawless rifle brace. The best part is, all it takes is a little programming know-how, a little elbow grease, and about 3000 hands in material costs.

For every Long Weapon Mount you have equipped, you can carry and use an additional long weapon with each attack action. You may never multi-shot with a mechanicle-mounted weapon. A -4 penalty is applied for every additional weapon used this way. Any weapon on a long weapon mount can neither critically succeed nor critically fail, but may gain the **Targeting Software** trait if you so desire.

When you enter guard mode with a weapon mounted on a long weapon mount, you may make reaction shots as normal against any number of applicable targets, instead of against only one. No extra penalties are applied to these additional reaction shots.

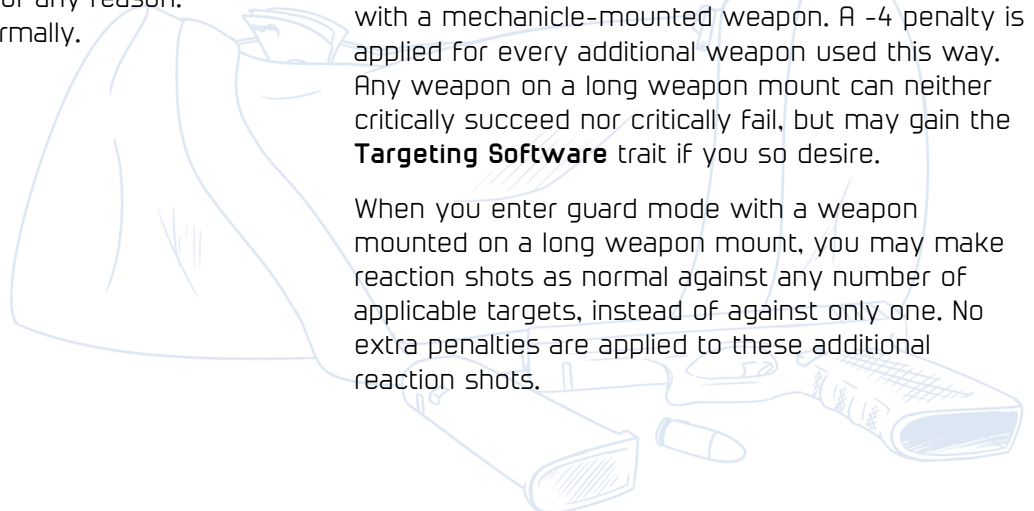



### **Short Weapon Mount (\$2500)**

#### **Requires one Mechanicle**

Second verse, same as the first, a little bit shorter and a little bit worse.

For every Short Weapon Mount you have equipped, you can carry and use an additional Short weapon with each attack action. You may never multi-shot with a mechanicle-mounted weapon. A -4 penalty is applied for every additional weapon used this way. Any weapon on a short weapon mount can neither critically succeed nor critically fail, but may gain the **Targeting Software** trait if you so desire.

When you enter guard mode with a weapon mounted on a short weapon mount, you may make reaction shots as normal against any number of applicable targets, instead of against only one. No extra penalties are applied to these additional reaction shots.

### **Octavian Ambulators (\$5000)**

#### **Requires Two Mechanicles**

Are you sick and tired of having to walk everywhere? Do you wish you could suction cup your way over the walls, ceilings, and windows of enclosed areas? Do you ever enjoy throwing old women off of buildings, or having rolling fistfights on the back of el trains? Then the Octavian Ambulators are right for you. This set of powerful mechanical limbs allows an unprecedented freedom of movement wherever you go! Strap em on, and climb up buildings and over cars—climb over pedestrians and small animals; squash your enemies like bugs while laughing maniacally from the back of your mechanical doomthrone. All this and more, with the Octavian Ambulators. Available wherever augments are sold.

For every pair of Octavian Ambulators you have equipped, you may use an action to move 5 tile spaces over any solid surface, regardless of its facing or verticality. This does not inflict penalties.

### **Equipment Mount (\$2500)**

#### **Requires one Mechanicle**

Just in case you wanna stick something on the end of your robo-arm that isn't a gun, but is a gussied-up version of something you already have, DivSys has generously provided the public with this easily-customizable equipment mount, which can be used to hold and operate most hardware on the market—affording you not only extra storage space, but extra utility.

For every Equipment mount you have installed, you can carry an additional piece of Equipment. Any equipment that is carried in this way can be used at no action cost; however, any rolls that they require will be penalized by -2, with an additional -4 for every other piece of equipment used in a single turn. You may only use any given piece of equipment in a mount once per turn.

### **Spot Welder (\$2500)**

#### **Requires one Mechanicle**

Not every Mechanicle function is just an extra knickknack holder: some of them are straight-dope hardcore original shit—like the CorpTechs Spot Welder Mechanicle attachment. Created to give high-risk construction workers a safe and easy way to rapidly weld metal together, it just so happens that Operators often need the very same utility.

While wearing a Spot Welder, you may weld shut any non-wooden door you encounter. While this is very noisy, it renders the door opaque and bulletproof, though not blast proof—effectively making it a wall.

## **Arm Augments: Longarms, Strongarms, TimetoGetTheFrictionOnArms**

### **CorpTechs Strongman 3 Muscular Enhancement Unit (\$20000)**

#### **Subdermal, Arms**

"My daddy's stronger than Hercules!" Heaven only knows how many proud children have made this boast; and with the CorpTechs Strongman 3, it can finally come true. Using a complex network of servos, microfibers, and endorphin enhancers, the Strongman 3 can enhance a person's strength by up to five times the norm—and that's enough to climb your very own Olympus!

The CorpTechs Strongman 3 MEU increases your unarmed damage by 1; and in clashes, it increases your clash success roll by 1.

### **Utiliton Multi-tool Black Mk. IV (\$3000)**

#### **Subdermal, Arms**

It's been around for over a hundred years, and it's STILL the way of the future. Since 2202, the CorpTechs Utiliton has been providing the gold standard of quality and ease, for thousands of workers nationwide. Now, Utiliton is better than ever, with the Black Edition Mark Four.

The Utiliton Multi-tool Black comes equipped with a pair of wire cutters, an electric screwdriver, a small saw, a can opener, a bottle opener, a USB stick, and

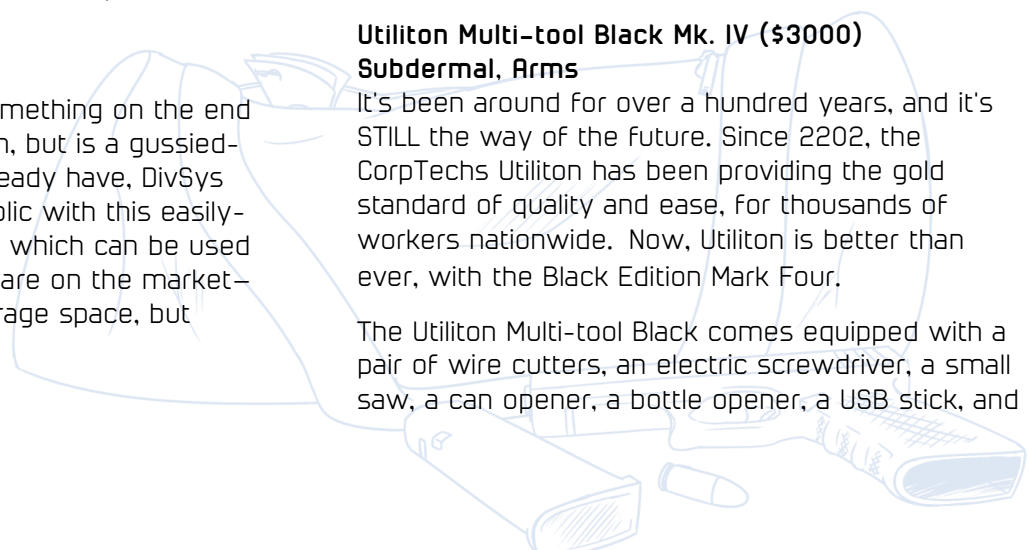

a magnifying glass. This allows you to cut through chain link fences, store data you encounter on computers, and probably some other stuff too.

### **Blackjack-pattern Grip Augmentation (\$30000)**

#### **External, Arms**

Are you tired of wrist strain? Do you just want more motor control? Then you need the Blackjack-pattern Gripping Augment, brought to you by CorpTechs. The most popular commercial-use hand replacement in the world, the Blackjack is flexible, responsive, and powerful. This is for Tendonitis, this is for Carpal Tunnel Syndrome, and this is for a few other things too. Get yours today!

The Blackjack-pattern Gripping Augmentation allows you to grab onto objects with your metal fingers with strength slightly in excess of what you would normally exhibit: for this reason it gives you +1 unarmed damage, and +1 on any clash success rolls you happen to make.

### **Snort and Whinny Acesleeve Ballistic Conversion Kit (\$35000)**

#### **External, Arms**

For all the gamblers of the world there's no understating the value of an ace up your sleeve. When you're sitting on a dead man's hand and the other guy throws down three aces, Snort and Whinny has your back: the Acesleeve conversion kit is the ultimate ballistic augment. By modifying your forelegs with an exo-skeleton and computing apparatus, and then your firearm of choice with a "Ready-rifling" barrel, the Acesleeve can track your eye movements and alter any given weapon's rifling, angle, and muzzle velocity to ensure that your shot hits its mark with over 92% accuracy. If you need to thread a needle, curve a bullet, or make a one-in-a-million shot, accept no substitutes.

While you have the Snort and Whinny Acesleeve Ballistic Conversion Kit installed, you may expend an additional action whenever you attack to activate it. After activating it, the first bullet, energy, or arrow-type projectile you fire that turn will ALWAYS hit its mark, so long as the target number of your murder roll, factoring all bonuses and penalties, is greater than 0. This ONLY applies to the first projectile fired each turn, regardless of the attributes or traits of the weapon it is fired from.

### **Twin Sun Designs Compensatory Cuffs (\$35000)**

#### **External, Arms**

Who doesn't want more? That's the question that the award-winning engineers of Twin Sun Designs asked themselves when they created the Compensatory Cuffs—and the result is a product just as prestigious as they are. By using an electromuscular implant to augment your natural strength, this small, stylish augmentation can reduce or completely eliminate muzzle climb.

While you have the Twin Sun Designs Compensatory Cuffs installed, you may ignore the first instance of any multishot penalties you incur, once per turn. However, this only applies to weapons you are carrying with your arms; and not weapons that you are operating via drones, augments, magic, or other means.

### **CorpTechs Akimbrace (\$50000)**

#### **External, Arms**

Have you ever wanted to tear through some place with two submachine guns tearing up everything in sight like you're in a Wachowski siblings movie? With the Akimbrace, you can. A pair of skeletal augmentations dramatically reduce the pain and inaccuracy that you would suffer from such things otherwise.

While wearing the CorpTechs Akimbrace, you may carry two short or compact weapons in the same inventory slot, and you may fire them simultaneously. There is no penalty for this, and penalties for multiple shots only increase by the normal +4 amount. Weapons must still be reloaded individually.

### **Olympus Sporting Goods Recoil Dampeners (\$25000)**

#### **External, Arms**

Boxing. Lifting. Shooting. In many sports, your wrists are at a constant risk, from force and rote repetition. With the power of Olympus and nanotechnology, you can put a damper on all those pains—and get back to doing the things you love. This simple and unobtrusive electromuscular brace can be customized to fit any arm, and grows with your muscles to ensure that there will never be pain or constriction. Get yours today—and get back to doing what YOU want to do!

While you have the Olympus Sporting Goods Recoil Dampeners installed, you may ignore 6 points' worth of the "recoil" trait, if you are using a weapon that has it.

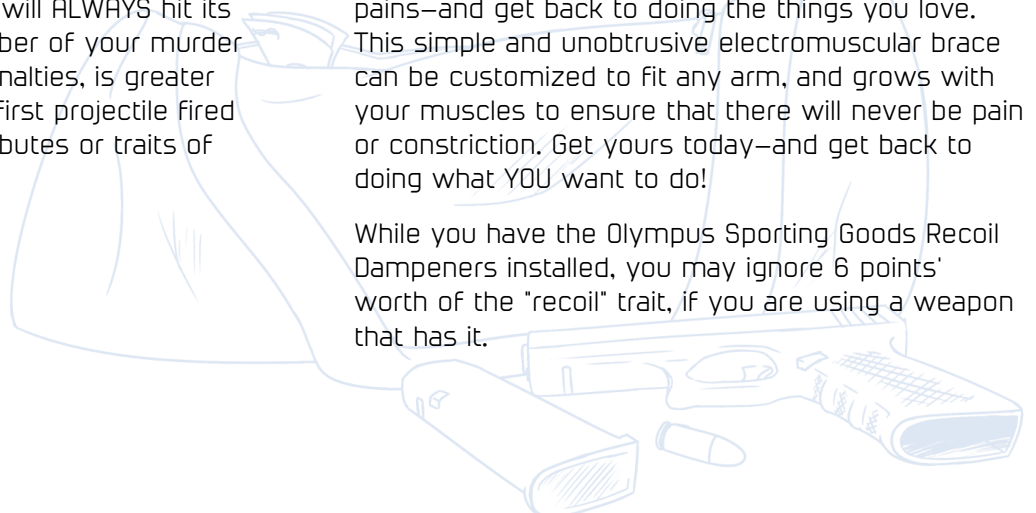

## Archon Enterprises Spider (\$10000)

### External, Arms

Say, for a moment, that you want to climb up a wall for some reason. Archon Enterprises can help you live out that dream with the one-of-a-kind Spider Augmentation. Mounted on your arms, the Spider is a set of elasteel spikes, which will extend on command and use an onboard nanotech colony to establish several thousand miniscule bridges to the rock, which can be terminated at any second. Do whatever a spider can!

The Archon Enterprises Spider lets you move up and around vertical faces like they were horizontal, at half your normal move speed. Doing so always requires an athletics roll.

## Waist Augments: Waists Of Time, Money

### Archon Enterprises Scorpion (\$15000)

#### External, Waist

Are you overworked? Overstressed? Do you find that you just can't keep up with the demands of your everyday life? Well, with the Archon Enterprises Scorpion, you can shave that stress down to size! Mounted on the tailbone, the Scorpion is a multi-segmented limb which interprets and stimulates the latent reflexes present in most mammals—in effect, giving you a fifth prehensile appendage. Whether you need some help around the house or an extra hand in the garage, the Archon Enterprises Scorpion is there to let you be your own little helper.

The Archon Enterprises Scorpion functions as a fifth limb with limited grabbing functionality, in effect allowing you to pick up and carry one extra duffel bag with you. Additionally, you can use it as an additional hand. This grants you one free unarmed attack at no penalty per attack action, which *can* be used as a clash.

### Apogee Satana "Skunkspray" Smokescreen (\$25000)

#### Subdermal, Waist

There's no way to make this augment any less profoundly disturbing, so we're not even going to try. Modeled after the skunk's most defining feature, and intended for use in desperate situations—such as when you're cuffed, gagged, and being escorted at gunpoint towards your impending execution—the APSF Smokescreen augment is a small capsule and dispersal unit mounted on the lower body below the tailbone. The device's implantation and application are remarkably uncomfortable for all involved

parties, but it might be better than whatever drove you to use it.

When you use the Apogee Satana Skunkspray Smokescreen, deploy a 5x5 smokescreen at your immediate location, with you being the center. This smokescreen will persist for 5 turns. Anyone and everyone with a view of your back must make a grit roll; in the event of failure, they will be tormented by a tremendous and abiding feeling of shame for the rest of their days.

For a 5000 credit surcharge, the smokescreen can instead emit a noxious and highly flammable gas that will inflict poison 2 on all enemies within its perimeter, and violently explode for 10 damage if exposed to fire.

### Archon "Billy Goat" Stabilizer (\$35000)

#### Subdermal, Waist

Waiters. Soldiers. Jackie Chan. Anyone who's ever needed to run really fast while precariously balancing something. All these people need the Billy Goat Gyropedic Stabilizer. This hip joint replacement keeps you balanced and nimble, whether you have two legs, or four legs, or tentacles. Buy a Billy Goat today, and keep your attention where you really want it.

While the Archon Enterprises Gyropedic Stabilizer is installed, you may spend an attack action to **Run and Gun**. When you Run and Gun, draw a straight line from your current position, to any square within your movement range, and move there. You may attack any enemy that passes within your weapon's effective range during this movement, at no penalty.

While the Archon Enterprises Gyropedic Stabilizer is equipped, your maximum power burst capacity is reduced by 1.

### CorpTechs Workhorse Spinal Augment (\$50000)

#### Subdermal, Waist

Work hard, live harder—that's the CorpTechs way; and when life gets too heavy to handle, we're there to put the power back in your hands. With our Workhorse Spinal Augmentation—which is used by over two hundred thousand workers, laborers, soldiers, and messengers worldwide—you can dynamically react to complicated shifts in weight and pressure that come with bearing heavy loads, while a cluster of intelligent nanomachines reinforces your most-stressed muscles, to give you the strength you need!

The CorpTechs Workhorse Spinal Augment allows you to ignore the effects of the "Heavy" trait. It also nullifies the movement penalty that comes with carrying characters.

## **Leg Augments: The Stuff of Leg Ends**

### **Shothopper Thigh Replacement (\$12500)**

#### **External, Legs**

As far as performance-enhancing combat augmentations go, the Shothopper is among the simplest. The Shothopper thigh replacement replaces several of your upper leg muscles with slightly overlarge mechanical tendons, while simultaneously inserting a spring-loaded compartment into your outer thigh. This compartment can hold magazines, warheads, and other projectiles of most sizes, and thereafter eject them at your prompting—saving you the effort of looking through your bags for heavy ammunition.

While the Shothopper Thigh Replacement is equipped, once per encounter you may reload your current weapon at half its normal action cost. If the weapon you choose to reload only requires one action to reload, it is reloaded at no action cost.

### **Featherfall Artificial Ankles (\$1500)**

#### **Subdermal, Legs**

Need a little extra hand when running? Don't want to deal with the stress of acrobatics? Afraid of leg and back pains? Then you need the Featherfall Artificial Ankle, from Olympus Sporting Goods! With an injection of biosteel, your hamstrings and Achilles tendon becomes several dozen times stronger, with no loss of flexibility. Featherfall in, muscle pain out. Ask your doctor today!

The Featherfall Artificial ankles allow you to safely fall from a distance of fifteen feet or less above ground. You do not need to roll athletics to make a good landing, and you will not take damage from the impact. Bear in mind that this effect only applies if you leap, and does not work if you fall or are pushed.

### **Olympus Sporting Goods Roundheel Ankle Extensions (\$25000)**

#### **External, Legs**

Have you ever wanted to move like the angelic ice dancers of Planet Christmas? Do you want to limbo like a Jamaican bureaucrat? With the roundheel ankle extensions, you can. This telescoping joint modification can increase your ankle flexion threefold, while maintaining the kind of strength only a machine can. The Roundheel Ankle extension

is a revolution in augment-positive competitive ice limbo: get yours today.

After evading a clash, you may make a single attack with your currently-equipped weapon against the person you evaded at no penalty.

### **Atlas Outfitting Anchor Ankle (\$7500)**

#### **Subdermal, Legs**

High winds, magnetism, snow—all of these and more can be involuntary movement hazards for an operator in the field. Fortunately, Atlas Outfitting has the answer: the Anchor Ankles, consist of a simple pair of pitons mounted in an electromagnetic projection tube; these are then affixed to the exterior sides of the ankles while adding minimal mass to the ankle area. Upon receiving the go signal, said pitons extend from the ankle and fire into the ground, and then retract when a second signal is given; allowing the user to remain rooted in place indefinitely.

While you have at least one Atlas Outfitting Anchor Ankle is installed, you may ignore any effects which would induce you to move involuntarily, so long as you did not use a movement action on your previous turn. While you have two Atlas Outfitting Anchor Ankles installed, you may ignore any effects which would induce you to move involuntarily.

### **Archon Enterprises Rabbit (\$15000)**

#### **External, Legs**

Are you sick of the ground and everybody on it? Are you tired of taking the stairs? Do you just enjoy jumping really high for little or no reason? If that's the case, the Archon Enterprises Rabbit augment is just what you've been looking for. By mounting a simple servo cluster on your thighs and a nanoforged piston over your Achilles tendons, the Rabbit can increase your vertical movement potential by over 1000%.

Please note that the Archon Enterprises rabbit does not harden bone and muscle structure against gravity-augmented impact.

The Archon Enterprises Rabbit allows you to leap up to thirty squares vertically. If you actually *do this*, however, and do not land on a higher position, you will take fall damage unless you have something to mitigate it.

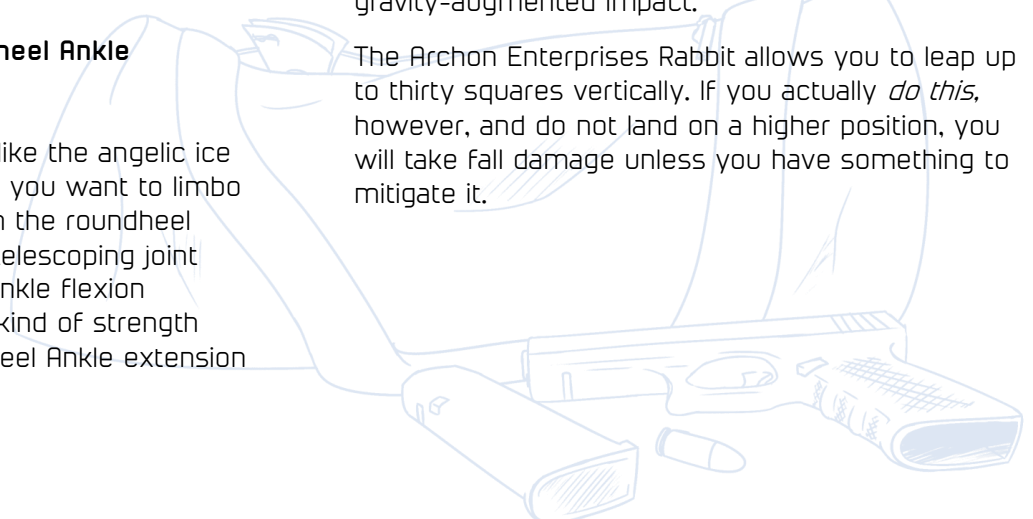

## Life Lessons: Something to Make you Better Than you Were

### Fluid Feline's Liquid Future Treatment (\$2500)

Hey kids! Are you tired of seeing the same old sights and thinking the same old things? If you are, everyone's favorite finely-feline FURoscientist has just the thing for you! Built off the roaring success of his award-winning Plasmousetrap, Fluid Feline has created a revolutionary new nanobot training regimen, which he has dubbed "Liquid Future"! Based around a series of unconscionably large needles, mind-warping posthypnotic suggestion, and several dozen highly invasive surgeries, a Liquid Future treatment can completely alter and erode decades of instinct, careful memorization, and rote reflex; and, with the touch of a button, replace them with something completely new! Learn martial arts, and forget high school math! Amaze your friends! Confuse your foes! And whatever you do, don't think about the philosophical ramifications of this thing! Fluid Feline's Liquid Future—it's a tradeoff, for the gambling man in all of us!

When you buy a Fluid Feline's Liquid Future Treatment, you may move one point from any skill into another—in effect, allowing you to re-allocate skill points as you would in character creation. However, this is only effective on skills you had at character creation, and may not be used to reallocate points in specialties that were acquired through Electric Eye E-Readers or other methods.

You may purchase as many Fluid Feline's Liquid Future Treatments as you want, provided you can afford them all.

### Electric Eye Night School E-Readers (\$12000)

Nobody's born knowing everything. In fact, most people are born knowing very little at all; and in a night job, where knowing is half the battle, ignorance can be a serious occupational hazard. Fortunately, we here at Electric Eye have taken it upon ourselves to make this job a little safer, with our award-winning Night School E-reader series. Containing over twenty thousand hours of lectures and instructional videos, and bundled with over three thousand pages' worth of detailed how-to-guides, the Night School books contain everything you need to learn the basics of explosives, poisons, getaway driving, narcotic manufacturing, weapon smithing, safecracking, trauma surgery, pole dancing, linguistics, mechanics, and more!

When you buy the Electric Eye Night School E-Reader, you may pick one Specialty skill which you do not currently have, and immediately gain 6 points in that skill. You may buy additional Night School E-readers to learn up to two *other* specialties. Once you have learned 3 specialties from Night School E-readers, you may continue purchasing them; however, when you do, you must pick one specialty you learned this way and reduce its level to 0—there's only so much you can commit to memory! If you have more than 3 Electric Eye E-readers, you may switch between relevant specialties between missions.

### Private Tutoring (\$25000)

Oooh! You were holding the damn thing upside-down this whole time!

When you purchase Private Tutoring, increase any specialty skill you learned from the Electric Eye E-reader to 8. If you swap out the specialty you increase this way for another, this bonus is removed until you purchase it again.





## Sample II: The Success

The first thing that this gang of punks know about their heist is what the bank looks like. They decide they need more information before they can hope to achieve a successful robbery, and dispatch Chatterbox to infiltrate the bank while posing as a potential client. Chatterbox enters the bank unarmed and discovers that the interior looks as it is displayed in figure 1. The vault (A) is the primary target.



*The players scout the interior of the bank.*

Having acquired a map of the interior thanks to Chatterbox's effort, Fixit decides to neutralize the wireless cameras. He withdraws his laptop and begins hacking them. He makes several successful hacking rolls and neutralizes the wireless cameras circled in figure 2.



With the security room and vault located, the group knows that the vault is guarded by a blast door; and since blast doors are always connected to terminals or fuseboxes, they have some indication of their next objective. Phantasm, relying on his stealthy movement abilities, uses his **Skytouch Grapnel Line** (Page 84) to move up to the roof of the bank, where he finds several air vents. Dropping into the crawl stance, he moves stealthily through the vent, and finds that it empties into the security room in front of the vault. Rolling stealth and athletics, he touches down nimbly behind the guard; and rolling stealth once again, uses his **blackjack** (page 63) to deal 2 damage to him; and because the weapon has the Assassin 4 trait, does an additional 4 damage to him as well. Moreover, because this is a sneak attack, the damage is tripled, which comes out to 18 damage and knocks the guard unconscious. The GM removes the token. Phantasm then inserts a **Hackmate Qthousand Slicing Tool** (Page 87) into the nearby console, allowing Fixit to operate the blast door at a later time. Realizing that, once they open the vault, there will be no way to extract the loot through the air vent, Scarlet n and Fixit move into position and begin laying preparations for first responders, in case they don't get to the escape point in time. They create a multi-pronged plan for quickly extracting loot, in coordination with the others. After placing several **Katiazucker Trip Mines** (Page 96) and **Portable Walls** (page 85), and getting into position, the map now appears as in Figure 3.

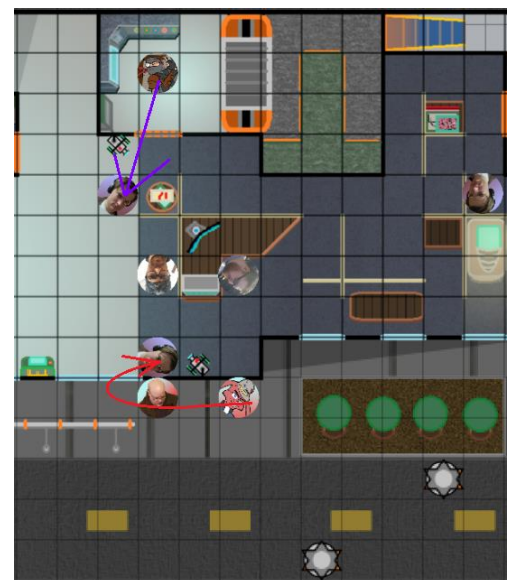

*The players take some time to figure out who's going to attack which target.*

At the same time, Fixit uses his **Blacktop 5000** (Page 87) in conjunction with Phantasm's **ID Tagger** (Page 98) to disable the electronic lock on the door to the security room, and the previously-planted Qthousand to open the vault door. As soon as the lock is open, Chatterbox gives the signal to move, and the crew begins their assault. Phantasm instantly exits the security room and attacks the guard in front of it with a blackjack, getting a sneak attack bonus and knocking the guard unconscious. At the same time, Scarlet shoots through the window of the building and attacks the nearest guard with her **sawed-off shotgun** (Page 64), which is loaded with **beanbag** shells (Page 100). After checking to make sure that the guard is within her weapon's effective range, she rolls murder, and succeeds; but because her weapon has the Automatic 2 trait, she **must** fire the weapon twice each attack—so she must roll murder again; But first, because her weapon has the shotgun 5 trait, she rolls 1d5 to see how many instances of damage she deals. Rolling a 3, she then does his shotgun's damage—which is 3, because of the beanbag shells—3 times, for a total of 9. Because this is also a sneak attack, however, each instance of damage dealt is multiplied by 3, which means she does a whopping 27 damage, and neatly knocks the guard unconscious. Repeating this process again for the second attack is a mere formality at this point, but she does it anyway because she likes doing lots of damage.

At the same time that this is happening, Chatterbox waves *her* weapon of choice—a **Black Stallion Assault Rifle** (page 60) at the assembled civilians. She shouts at them to get on the ground and surrender; and since they do not have the capacity to resist as defined in **Running A Game II: Populating the Map**, they all comply. Since they no longer figure in the game, the GM removes them from the board; he will re-add them if they are needed later. Finally, Fixit moves through the newly-broken window and deploys a Zipline (Page 86), aiming it into the security room. The round ends, and the map now looks like figure 4. The zipline here is highlighted in red, for your convenience.

The GM then rolls for first responders to arrive: the players realize, to their chagrin, that there was a silent alarm secured via fusebox on the roof, but they did not disable it before triggering it. What could have been a perfect robbery will now be confounded by the arrival of the police in a few turns. The GM rolls 1d10, and adds the gang's infamy value, which is 3, to the number rolled. The resultant number is 7—so the police will arrive in 7 turns.

The players, though, being reasonably intelligent people, decide that they cannot afford to wait that long to begin work. Since the surprise round is over, all of the characters in the scene roll initiative: 1d10, plus the character's athletics skill. The players roll for their characters, while the GM rolls for the security guards. In a scenario with a larger number of enemies, the players might help expedite the process by rolling certain enemies' initiative alongside the GM. For now, though, they do not. Once the initiative rolls are done, the turn order is as follows:

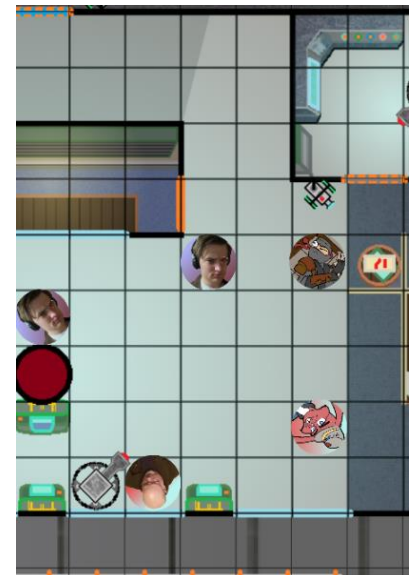

Figure 4

Scarlet (Athletics 10, roll 9, initiative 19)

Security Guard 2 (6, 10, 16)

Chatterbox (6, 9, 15)

Security Guard 1 (6, 6, 12)

Phantasm (8, 4, 12)

Fixit (6, 5, 11)

Security Guard 3 (4, 6, 10)

Security Guard 4 (4, 6, 10)

Security Guard 5 (2, 6, 8)

The Civilians: (0, because they suck.)



Scarlet takes her turn first because her initiative score is the highest. Since she fired her weapon twice in her last turn, she has expended all of its CAP and must reload it; however, because the weapon has the Slowloader trait, she does not want to take the time to do so without neutralizing the immediate threats. The first thing she will want to do is shoot the security guard next to the teller's booth—Security Guard 1. To do so, she will use her **Selleck-pattern revolver** (Page 60), which does 6 damage and has the **pierce: Ceramic** trait. She rolls murder, and succeeds; and since the guard is wearing mesh armor, which is weaker than ceramic, he takes 6 damage directly to his health. This is enough to badly wound him, but not kill him. Thus, Scarlet decides to **Multi-shot**, which allows her to make another attack at -4 penalty, but no additional action cost—as defined in **Combat VII: Combat Actions**. She rolls a 5, which succeeds; and so the guard again takes 6 damage, and dies. Her attack thus concluded, Scarlet decides she is going to move. Because her athletics score is 10, she can move 10 spaces with one action. She chooses to move to the northwest, in front of the teller booth door.

Next is Security Guard 2's turn. The guard wants to attack Scarlet, and he will be doing so with his **Splitfoot Submachine Gun** (Page 60). The weapon in question has a damage of 1, and the **automatic 5** trait. To determine line of sight, the guard would draw a line from himself to Scarlet; and because he is in cover, he is allowed to draw from a space immediately adjacent to him. The line he draws looks like this:

We can clearly see that this line passes through the edge of Scarlet's cover, so the guard suffers a staggering -6 penalty to any attacks he makes. Given that the guard only has a murder score of 5, he would be completely unable to damage Scarlet in any way, and decides to move into better position. The guard moves southwest, to an advantageous position, and makes his attack. He rolls 5d10, 2 of which land under the target number of 5. This means that he deals 1 damage to Scarlet, twice. Because Scarlet is wearing the powerful **Juggernaut Armor (page 78)**, which has a whopping 8 armor, this attack does no damage to her. She laughs at the guard, who is about to die.

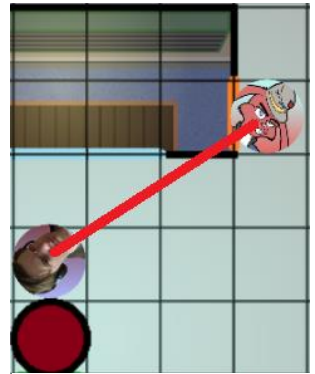

*Scarlet is in cover.*

You can probably figure out what happens next, but suffice to say that it ends with a lot of people dead or unconscious. While Scarlet and Phantasm deal with the Security Guards, Chatterbox moves into position behind the pillar in the center of the bank and keeps watch on the civilians, to ensure nobody gets any ideas about running away. Because they are civilians (and therefore suck), and she has maintained her line of sight to them, they do not. She attacks the security guards as necessary to support her teammates. While she does this, Fixit rides his own zipline into the guard security station, and enters the vault. He will begin bagging loot now.

Because Scarlet and Phantasm are very good at the job, they don't have much trouble with the security. It takes 3 further turns for them to pacify or kill the remaining security guards, which leaves them with 3 turns before the police arrive. Fixit has spent this time dumping money out of the loot zone and into his duffel bags. Because he has had six whole actions to do so, and has been rolling **1d20x1000** each time, it's no surprise that he has already put away a significant 50000 hands, filling up 2 of his 3 duffel bags. Preparing to make a hasty retreat in their escape car, Scarlet double-moves to exit the bank. She will spend the following two turns reloading her weapons, to make sure he can engage the responders as efficiently as possible. Chatterbox, who has secured two hostages with her turns, then moves into the vault. She begins loading her own bag, and gains an additional 25000 hands. Fixit sends one bag along the zipline, and returns to the vault to get his second one. Phantasm, meanwhile, exits the bank through the West Side, and spends one turn standing still so that his **Hargreave Combat Armor (Page 81)** activates its special effect, rendering him invisible. The map now looks like this.



The reinforcement timer has run down, and the police arrive. Because the group has been doing well so far, the GM decides to issue them a moderately difficult challenge, and places down 12 points' worth of police officers. Because this is an entirely new group of enemies, and there were no enemies left over from the previous group, everyone—including players—rolls initiative.

Assault 1: (10, 10, 20)



Assault 2: (10, 9, 19)

Scarlet: (10, 9, 19)

Phantasm: (8, 10, 18)

Assault 3: (10, 7, 17)

Assault 4: (10, 7, 17)

Juggernaut 1: (10, 7, 17)



Juggernaut 2: (10, 6, 16)

Sergeant 1: (6, 7, 13)



Sergeant 2: (6, 6, 12)

Marksman 1: (5, 6, 11)



Marksman 2: (5, 4, 9)

Fixit: (6, 2, 8)

Chatterbox (6, 2, 8)

This time, the police seem to have something of a leg up on the players as far as initiative goes. They might be in real trouble. The GM places the police on the map any way he wants. In this case, they arrive via vehicle, from both nearby streets. This triggers the landmine which Scarlet had planted earlier—neatly eliminating the first police cruiser, which contained two assaulters, one juggernaut, and a sergeant. This leaves assaults 1 and 2, juggernaut 1, and sergeant 1—as well as the marksmen. The assaults exit their vehicle and approach the bank, moving into position to try and apprehend Fixit and Chatterbox—“apprehend” here means “shoot them like clay pigeons”. They both enter the **Guard** stance, which will allow them to attack anyone who enters their line of sight, as defined in **Combat VII: Combat Actions**.

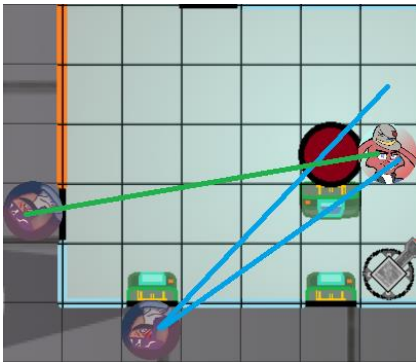

Scarlet, meanwhile, will move to keep her teammates safe. Since the assaults are carrying the modestly-powerful Killswitch shotguns, she doesn't want to risk the possibility that they could breach her armor. To move into position without triggering their reaction attacks, Scarlet uses a move action to **Tumble** into cover. She makes sure to end her movement in cover to both targets, so that they do not get a reaction shot on her (as demonstrated to the left).

She then attacks the assault behind the column with her **Thunderbolt Assault Shotgun (Page 65)**. She can draw a line from an adjacent space to the target; however, the assault officer still gets cover (as demonstrated to the right).

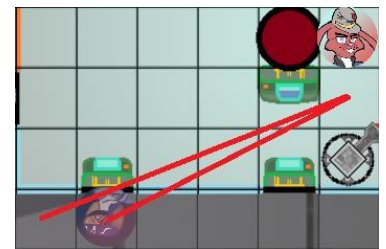

Because the assault officer is in cover, Scarlet's attacks suffer a powerful -6 penalty. She rolls 2d10 since the weapon has automatic 2. Only one of her two attacks connects; and since her weapon has **shotgun 2**, she rolls 1d2—or flips a coin—to determine how much she multiplies the damage by. She rolls a 2, which means that she multiplies the weapon's damage by that much. It does a healthy 8 damage—which is enough to shred the assault officer's armor, and do 3 damage to the officer's health. Wanting to finish the job, Scarlet decides she will multi-shot—which inflicts a -4 penalty. This, combined with the -6 penalty from cover, means that her attack has no chance of hitting, so she decides to use a **Power Burst**. This will allow her to negate one kind of penalty of his choice, as explained in **Playing the Game V: Rolling and Power Bursts**. While she **could** negate the multi-shot penalty, she decides she will negate the cover penalty, since it is larger. She makes her second attack, **only** suffering the -4 multishot penalty; and this does enough damage to incapacitate the officer.

Phantasm, meanwhile, breaks stealth and moves southwards. If he were still sneaking, the enemies would not have noticed them since their senses are occupied; but since he is now visible, the assault officer stationed there can see him; and when he moves into range, the officer makes his reaction attack. This attack connects, and does 4 damage, twice. Because 4 damage is equal to half of the Hargreave suit's 8 armor, this is enough to damage the armor. The Hargreave thus takes 8 damage, which is enough to leave Phantasm exposed; but more than that, it is enough to stop his movement dead in his tracks! With only one action left, and the guards still out of range of his weapons, Phantasm is forced to seek shelter behind the pillar in the center of the bank.

The Juggernaut and Sergeant move into position at the front of the bank and both engage guard mode—preparing to gun down any punks moving through the area. Finally, the marksmen exit their vehicle and take up position around the edges, which will give them a suitable vantage point against Scarlet and anyone else exiting the bank. Things look decidedly grim, and unless our villains come up with something clever they will likely be cut down in a few short turns.

Fixit rides the zipline out of the building, and—not wanting to leave gear behind—uses his second action to dismantle it and stuff it back onto his equipment rack. While riding the zipline exposes him to the enemy, he counts as being in cover while riding it; and so the police choose to ignore him in favor of trying to attack Chatterbox when she exits the security room. Chatterbox, who has no intention of getting shot, tumbles out of the security room and into the cubicles, which serve as cover from the police waiting outside the bank entrance, and the snipers poised to the south. As the combat round ends, the map looks like this:



Now that another combat round is beginning, the initiative list is altered: everyone who is dead is erased, scratched off, or deleted as is appropriate. Then, the round begins again.

The remaining assault officer, trusting in the sergeant and juggernaut to take care of the others, moves to deal with Phantasm. The assault officer instead decides to issue a **Freeze!** command to him, as defined in **Combat Actions**. To do so, he must position himself near Phantasm, within a number of squares equal to **his acting score+1**. Since this assault has an acting score of 0, he will have to position himself directly next to Phantasm before he can issue a Freeze! command. Phantasm, having been frozen, will be **instantly incapacitated** if he takes any movement action other than tumbling into cover; and if he remains frozen for the rest of this combat round, he will be eligible for arrest. Instead of exposing himself or remaining frozen, Phantasm decides to **attack** the officer. Since he is frozen, he is only afforded a **single** attack against the officer before he is incapacitated; so, fearful of the possibility that he might be unable to incapacitate the officer with a weapon strike, he decides to engage in a **clash**. This, he hopes, will be able to defeat the officer without exposing himself to reaction fire.

When the clash begins, both of the participants roll a number of d10's equal to **half** their murder skill rounding down. In Phantasm's case, this is 5; and in the Assault's case, this is 4. They both declare their weapons: Phantasm is **unarmed**, while the assault is using his rifle butt. Then they roll their dice in whichever order is most convenient for the players, and then tally up the number rolled. The numbers are, respectively, 35 and 18, which means that Phantasm is the winner. Because he is the winner, Phantasm rolls 1d5—which is done by rolling 1d10, halving the number rolled, and rounding up—and compares the number rolled against the **nonlethal clash success table** (page 27). The number rolled is a 4, which corresponds to the Cripple effect; but because Phantasm has 2 **Blackjack-pattern gripping augments** (page 110) installed on his person, that number is instead increased to a devastating 6—an instant knockout. Because engaging a clash costs an action but resolving it does not, Phantasm has 1 action left, which he uses to tumble through the previously-broken window and into cover at the edge of the bank.

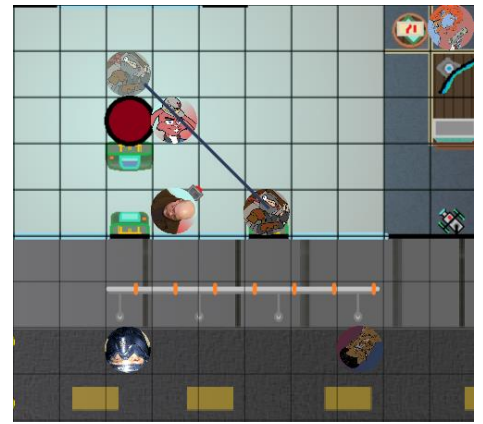

*Phantasm's tumble range is half his athletics. He can tumble up to 5 spaces.*



*The juggernaut and Phantasm share a single piece of cover. Neither is safe from the other.*

The Sergeant and Juggernaut move into the bank now. The Juggernaut takes a gamble and moves up directly next to Phantasm. Even though the wall is directly between them, because they are using the same piece of wall as cover, neither one counts as being in cover from the other. The juggernaut leans around the corner and attacks Phantasm with his automatic shotgun. This attack is not penalized; and since Phantasm's armor was previously broken, it does enough damage to incapacitate him. Phantasm is **incapacitated**—and is now in danger of **bleeding to death**. The sergeant and marksmen, meanwhile, merely resume guarding and wait for someone to enter their lines of sight—they seem quite clearly to have the situation on lockdown.

Chatterbox appraises the situation and decides that she has a low chance of surviving the sniper fire outside the building. Thinking quickly, she decides to give herself a leg up on the competition: channeling her mastery of artistry, she draws two doodles: **Fake Wall** (Page 70) and **Barrier** (Page 70). She first casts Fake Wall, which has an IP cost of 3, and allows her to designate three contiguous spaces of the map and render them opaque. She chooses three squares near the snipers' perch—blocking off their lines of sight, to prevent them from being able to use their reaction attacks. She rolls Artistry to determine the scribble's success; and when the roll passes, it takes effect. She then casts another spell—Barrier—on herself. Because this is casting a second spell in a single attack action, she suffers a multi-shot penalty; and because it is a target other than the one she first targeted this action, she ALSO suffers a whopping -6 multi-target penalty. Clearly, a power burst is in order. She decides to spend one burst to ignore the multi-target penalty, and then rolls the dice. The resulting number, 9, is too high for her scribble to be a success, even with a power burst; so, she decides to spend **another** power burst, and negate the multi-shot penalty as well. Now that the barrier spell has succeeded, she has **5** points of SHD on top of her armor points.



She moves out into the bank, towards the escape vehicle. She punches through the window, taking 1d3 glass damage (in this case taking only 1)—but shock of shocks, she is attacked by the sergeant who was waiting for her! The sergeant rolls his attack dice, and does 4 damage to Chatterbox—her shield decreases by the appropriate amount, but since she did not suffer damage to health or armor, her movement is not interrupted like Phantasm's was. She continues across the bank and into cover. This combat round has ended and the map now looks like this:

Scarlet uses her turn to move to Phantasm's side, and lift him up onto her shoulders. Since she has not stabilized him, Phantasm is still at risk of bleed-out; but Scarlet intends to extract him from the location before that can happen. Phantasm, having been incapacitated, cannot take any action this turn; and must roll grit to avoid bleeding out. He rolls 8 with a target of 8 and passes. The juggernaut and sergeant both move into position; and, perhaps rashly, open fire on him. While their attacks are unpenalized, Scarlets' body armor is mighty: even though the assault shotgun breaks her armor, and the two assault rifle bullets deal 8 damage to



*The police are left impotently stomping on their hats as the punks reach the escape zone.*

her, her whopping 15 health points means she is not defeated. Fixit, meanwhile, makes a break for it. With the snipers' vision still obscured by the fake wall, they are unable to take any action; and so on their next turns, Chatterbox and Scarlet (carrying Phantasm) both proceed into the escape zone, and exit the map.

While they sustained some minor wounds and one incapacitation, the punks managed to escape with all of their gear, without any lasting casualties, and with 75000 hands. Over the next few days, Phantasm will recover from his wounds; and soon, they will invest their ill-gotten gains in better equipment; and after that, they will continue their life of crime, until either they retire or die. Through careful planning and use of their skills and equipment, they have won the day.

## What Can we Learn From This?

If you learn nothing else from the successful example, take away these three essential points:

- **Preparation is everything.** If you want to succeed in the life of crime, you will need to have a plan, a backup plan, and a backup plan for your backup plan. A winning team will always have a map of their target, clearly designated objectives, and a well-communicated understanding of where everyone is and what everyone will be doing. Any equipment they think they will need is acquired before the action starts, and everyone knows how and when to use it. Keep in touch with your teammates, go over your plans multiple times if need be, and make sure everyone understands everything. In Toonpunk, damage comes fast, and playing gung-ho is an elaborate form of suicide.
- **Make full use of your equipment.** There are numerous tools and tactics at your disposal. You won't get very far if you rely on only one of them. Your crew will need to make use of a varied approach: stealth, hacking, acting, and murder can all contribute to the success of a heist; and everyone should be ready to mix up their approach. Actors should be ready to both seduce and threaten, to both make themselves meek and project their presence; sneakers should be ready to climb over rooftops and through the muck, removing or evading targets as need be; and murderers should be ready to engage all kinds of targets at many different ranges. You must think carefully about what you have at your disposal, and use each tool to its fullest extent.
- **Don't Panic.** Cooler heads prevail. Coordinate with your team, be ready to transition to a backup plan if things go awry, and have a clearly-established chain of command. A poorly-planned and underequipped heist *may* fail; but any heist executed by panicky trigger-happy people *will* fail.

# Templates I: Sample Statlines and Loadouts for Player Characters

**The Legendary Knight:** Fast on his feet and deadly as a crotch full of the Badger Crabs, the Knight is what you use to turn a room full of guys into a puree. This warrior uses a sword and shotgun to overwhelm melee targets with lethal efficiency. He wears only light armor, and relies on his ballistic shield to help him close the distance. His primary strengths are his high athletics and murder abilities. However, his secret weapon is his high nonsense score: which, when used with his medallion, allows him to shatter the normal limits of the game—he can push his Murder skill all the way up to 20, or clash with a whole cluster of enemies at once!

**Species:** Anime

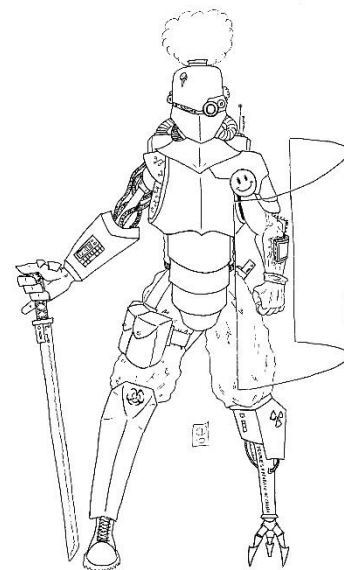

Perception: 4	Grit: 8
Acting: 0	Athletics: 8
Stealth: 0	Murder: 10
Hacking: -1	Artistry: 0
Hardware: -1	Nonsense: 10

Situational Items
Sergeant-Pattern Ballistic Shield
Pocket Sand
Kobutodo-Z China Broom Shotgun
Quickdraw Holster
Div/Atlas Achilles Protection Suit

Essential Items
Atlas Heavy Impact Jacket
Blessed Medallion
Kapricorn Longsword
S&W Sawed-Off Shotgun
Duffel Bag

Ideal Augmentation
Twin Suns Compensatory Cuffs (Arms)
Archon "Billy Goat" Stabilizer (Waist)
Archon "Scorpion" (Waist)
CorpTechs Strongman 3 (Arms)
CorpTechs Hexagon 2 (Back)

**The Geek:** He's good for more than biting the heads off of chickens. The geek isn't much for looking or talking, but that's the way he likes it: he prefers to speak through his garrote wire, his multitool, and his suite of powerful cyberweapons. His hardware and hacking are his best utilities: with these, he can wedge open doors, turn off lights, and disable cameras—and when an environment has been altered to his liking, he steals like a whisper through the deep shadows he has created, strangling the life out of those in his path and claiming any treasure he likes.

**Species:** Shill

Perception: 4	Grit: 0
Acting: 0	Athletics: 8
Stealth: 10	Murder: -1
Hacking: 10	Artistry: 0
Hardware: 8	Nonsense: 0

Situational Items
APSF Glass Cutter
Olympus Thermal Glasses
Atlas Sporting Goods Compound Bow
Ketamine Belt
DivSys Hargreave Infiltration Suit

Essential Items
Garrote Wire
CSC Comdom
Olympus Grapnel Line
Cardboard Box
Blackjack

Ideal Augmentation
Twin Suns Compensatory Cuffs (Arms)
Olympus Recoil Dampeners (Arms)
Titanio Body Shield (Chest)
CorpTechs Workhorse (Waist)
OuchEaze Cardiostabilizer (Chest)

**The Field Boss:** She talks the talk, she walks the walk. The Boss is charismatic, perceptive, and dangerous. She can't do everything, but she can command the people who do what she can't. Usually preferring to stay out of the fight and keep her enemy at length, she keeps a rifle and ceramic vest in case things get hairy. Her best assets are her high perception and acting skills: with these she can hold an entire bank hostage on her lonesome, direct her allies where they are needed most, and issue Freeze! commands to anyone who gets any funny ideas about killing her.

**Species:** Meatman

Perception: 10	Grit: 6
Acting: 10	Athletics: 7
Stealth: 0	Murder: 9
Hacking: -1	Artistry: 0
Hardware: -1	Nonsense: 2

Situational Items
Electric Eye ID For Everything
CorpTechs EZDye
Coral King Deadly Viper Dart
Atlas Outfitting Juggernaut Jacket
Thunderbolt Assault Shotgun

Essential Items
Club Lucius Duster Coat
Atlas Heavy Impact Jacket
Black Stallion Assault Rifle
Operator's Helmet
LunaSea Operator's Pistol

Ideal Augmentation
Peeping Tim + (Skull)
Olympus Recoil Dampeners (Arms)
Atlas Titanio Body Shield (Chest)
CorpTechs Workhorse (Waist)
OuchEaze Cardiostabilizer (Chest)

**The Clone of Bruce Lee:** He dives, he dashes, and he has thirty different Jeet Kune Do actions! The Clone of Bruce Lee might not look like the heavyweight athlete of the day, but he has awesome punching, kicking, and grappling power! With high martial arts and athletics skills, he can zip around the battlefield working his trade. Against unarmored enemies he can swing devastating Hong Kong Heart Punches that can drain an entire health bar instantly; and anything he can't punch, he can pull into a deadly clash! His only drawback is that in order to be effective, he must wear prohibitively light armor—he must use the environment carefully, or be gunned down in his prime.

**Species:** Golden Ager

Perception: 4	Grit: 6
Acting: 0	Athletics: 6
Stealth: 8	Murder: 10
Hacking: -1	Artistry: 0
Hardware: -1	Nonsense: 4

Situational Items
Garrote Wire
Thunderbolt Expressway rifle
Twin Suns Hurricane Machine Gun
Twin Suns Windstorm SMG
DivSys Hargreave Infiltration Suit

Essential Items
Club Lucius Duster Coat
Atlas Heavy Impact Jacket
Thunderbolt G30 Rifle
LunaSea Operator's Pistol
S&W Compact Shotgun

Ideal Augmentation
Twin Suns Compensatory Cuffs (Arms)
Olympus Recoil Dampeners (Arms)
Titanio Body Shield (Chest)
CorpTechs Workhorse (Waist)
OuchEaze Cardiostabilizer (Chest)

**The Solo Infiltrator:** The Solo Infiltrator is a myth among field operatives: able to sneak past and eliminate conventional security as easily as survive a pitched battle, she's the total package for low-tech operations. She's sneaky, she's gritty, she's athletic, and she's murderous. Armed with a knife and scout rifle for sneaky target elimination, the solo infiltrator also carries an assault rifle and a set of grenades in case she is discovered. She can wear many kinds of armor, depending on the precise nature of the task at hand; and if she encounters any tech in the field, she can bring an ID tag to give her allies a long-range in.

**Species:** Scrapper

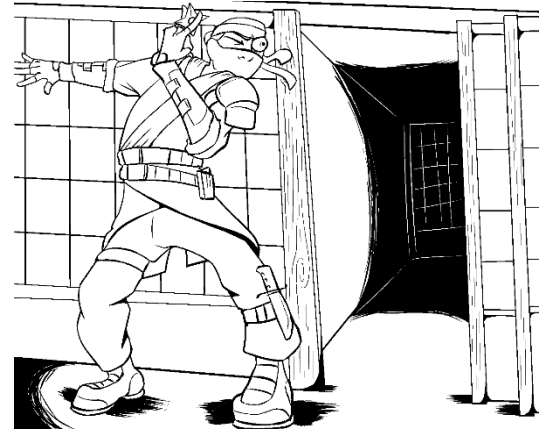

Perception: 4	Grit: 6
Acting: 0	Athletics: 6
Stealth: 8	Murder: 10
Hacking: -1	Artistry: 0
Hardware: -1	Nonsense: 4

Situational Items
Garrote Wire
Thunderbolt Expressway rifle
CorpTechs ID Tagger
Twin Suns Windstorm SMG
DivSys Hargreave Infiltration Suit

Essential Items
Atlas Heavy Impact Jacket
Kessler Munitions Handifragmintir Mk 1
LunaSea Scout Rifle
Black Stallion Assault Rifle
LunaSea Operator's Pistol
LunaSea Survival and Combat Knife
CorpTechs Quickdraw Weapon Holster

Ideal Augmentation
Twin Suns Compensatory Cuffs (Arms)
Olympus Recoil Dampeners (Arms)
Titanio Body Shield (Chest)
CorpTechs Workhorse (Waist)
OuchEaze Cardiostabilizer (Chest)

**The Big Guy:** It's The Big Guy! He's HUGE! He's got biceps like watermelons and abs like someone glued a bunch of snakes together! He wears huge armor and carries a huge gun, and he's got a huge grit, murder, and athletics score. With a whole suite of durability-enhancing augments packed into his body, he's a really hard target—the kind that can only be taken down by a bazooka, or a full blast from a top-of-the-line machine gun. The big guy stands in the middle of the room waving his flamethrower around like he's trying to do every part of the hokey pokey at once; and when he's done, his teammates kill whatever he didn't.

**Species:** Classic

Perception: 6	Grit: 10
Acting: 0	Athletics: 10
Stealth: 0	Murder: 10
Hacking: -1	Artistry: 0
Hardware: -1	Nonsense: 2

Situational Items
Large Explosive Weapons Device
Thunderbolt Expressway rifle
TCE Radcannon
Atlas Outfitting GUT Tactical Vest
Div/Atlas Achilles Protection Suit

Essential Items
Operator's Helmet
Atlas Juggernaut Jacket
TSD Hurricane Machine Gun
Hashimoto Hotgun
Kessler Munitions Handifragmintir Mk 1

Ideal Augmentation
Twin Suns Compensatory Cuffs (Arms)
CorpTechs Hexagon 2 Shield (Back)
Titanio Body Shield (Chest)
CorpTechs Workhorse (Waist)
OuchEaze Little Helpers (Global)



**The Femme Fatale:** Boys, watch out. Girls, watch out too, because the femme fatale will make a fool out of anyone and everyone. Her ostentatious and erudite behavior conceals a calculating mind and a set of light fingers. With her stealth and acting prowess, she can steal hearts just by walking into a room, and steal wallets every bit as easily. If things go bad and she gets caught, she can make use of a smoke bomb or grappling hook to escape the situation before it gets lethal; and use her careful step and high mobility to scout for her burlier, less civil teammates. Remember...she's not a bad girl. She's just drawn that way.

**Species:** Smut



Perception: 6	Grit: 4
Acting: 10	Athletics: 10
Stealth: 10	Murder: -1
Hacking: 0	Artistry: 0
Hardware: -1	Nonsense: 0

Situational Items
Blackjack
Ketamine Belt
Softened Tabi
Portable Hole (In a Can)
Handifragmintir MK 1 ..just in case.

Essential Items
Divinity Systems MDA Suit
Garrote Wire
Coral King Deadly Viper Dart
CorpTechs EZDye
Electric Eye ID for Everything

Ideal Augmentation
Archon Enterprises Spider (Arms)
Featherfall Artificial Ankles (Legs)
Archon Enterprises Rabbit (Legs)
Technicular Dreamcoat (Global)
OuchEaze Cardiostabilizer (Chest)

**Herr Doctor:** When you need to get patched up in a hurry, nobody's as good as Herr Doctor. This fearless and clever back-alley surgeon will fix your augments, stuff your organs back in their holes, and stitch up said holes without getting so much as queasy. Sure, he may be using stolen technology and body parts that were pulled off of homeless people, but beggars can't be choosers. Herr Doctor will use his surgery and medical skills to keep you alive, his athletics to get where you need him, and his weird accent to make you wonder if that syringe *really* needs to be so large.

**Species:** Classic

Perception: 4	Grit: 6
Acting: 0	Athletics: 6
Stealth: 8	Murder: 10
Hacking: -1	Artistry: 0
Hardware: -1	Nonsense: 4

Situational Items
Garrote Wire
Thunderbolt Expressway rifle
Twin Suns Hurricane Machine Gun
Twin Suns Windstorm SMG
DivSys Hargreave Infiltration Suit

Essential Items
Club Lucius Duster Coat
Atlas Heavy Impact Jacket
Thunderbolt G30 Rifle
LunaSea Operator's Pistol
S&W Compact Shotgun

Ideal Augmentation
Twin Suns Compensatory Cuffs (Arms)
Olympus Recoil Dampeners (Arms)
Titanio Body Shield (Chest)
CorpTechs Workhorse (Waist)
OuchEaze Cardiostabilizer (Chest)

**The Illustrator:** Kind, gentle, and artistic, the illustrator doesn't ply murderous trades the same way her companions do. She mostly just wants a place where she can doodle in peace—and is willing to accept that sometimes, she has to fight tooth and nail to get that. With low hacking, stealth, and murder, she's not much great on her lonesome; but the illustrator's strength is in being able to support her allies with a wide variety of shields, debuffs, and utilities. Using her incredible Artistry and Nonsense scores, she can keep her enemy on their back heels while continually pressing her allies' advantage; and when she needs to, she can expend a few power bursts to turn the room into a torrent of ink and cuss words for a few horrible seconds.

**Species:** Golden Ager

Perception: 6	Grit: 8
Acting: 8	Athletics: 6
Stealth: 0	Murder: -1
Hacking: -1	Artistry: 10
Hardware: -1	Nonsense: 4

Situational Items
Basic Cognitive Enhancer
Line in the Sand
Prescience
Flash Step
Hellmouth

Essential Items
Oracle Outflow Improvement Vest
Peel
Barrier
Lift
Fake Wall

Ideal Augmentation
Just
Get
Some
More
Spells

**The Founder of the Feast:** Some nice shoes, a nicer suit, and a look that can kill most men dead. The Founder of the Feast isn't much good in a fight—but, that's what she pays *you* for. The Founder isn't much good with strategy, but that's what she pays The Boss for. So what *does* the Founder do? She knows how to move money, and information. Hook her up with a computer terminal and she can turn 2500 hands into 20000, given a few days and the right people. While she spends most of the job hiding in the van, her skills with technology and people means she can open doors, lay secrets bare, and provide all the support a team could ever want.

**Note:** The recommended skillset in this profile only spends 24 points instead of 36. The other 12 should be used on the specialties of your choice!

**Species:** Who cares? She just sits in the van the whole time!

Perception: 4	Grit: 0
Acting: 10	Athletics: 0
Stealth: 0	Murder: 0
Hacking: 10	Artistry: 0
Hardware: 0	Nonsense: 0

Situational Items
Garrote Wire
Thunderbolt Expressway rifle
Twin Suns Hurricane Machine Gun
Twin Suns Windstorm SMG
DivSys Hargreave Infiltration Suit

Essential Items
Club Lucius Duster Coat
Atlas Heavy Impact Jacket
Thunderbolt G30 Rifle
LunaSea Operator's Pistol
S&W Compact Shotgun

Ideal Augmentation
Twin Suns Compensatory Cuffs (Arms)
Olympus Recoil Dampeners (Arms)
Titanio Body Shield (Chest)
CorpTechs Workhorse (Waist)
OuchEaze Cardiostabilizer (Chest)

## Templates II: Sample Enemies, Both Weak and Strong

### 1/2 Point Enemies: Low Level Goons You Can Beat Up Easy

**Rent-a-Cop:** These poor security guards have little education, minimal physical training, and a truly pathetic array of armaments. They are unlikely to defeat you with anything less than divine intervention, and even then the odds are still about 30/70 your way. The most dangerous thing they can do is call somebody else to the scene of your crime.

Perception: 0	Grit: 0
Acting: 0	Athletics: 6
Stealth: 0	Murder: 6
Hacking: 0	Artistry: 0
Hardware: 0	Nonsense: 0

Suggested Items
S&W Mayfly Repeater

**Zombie:** It turns out, a frankly obscene number of zombies have been drawn over the years—and that was *before* the zombie virus boom. The point is, statistically speaking most of the planets in local space have some kind of horrible zombie-like monstrosity living somewhere on it—either below its surface, in the bowels of its cities, or its radioactive waste dump. Zombies know no fear, have no sense, and all they want to do is eat your brains. Good luck with that.

Perception: 2	Grit: 3
Acting: 0	Athletics: 5
Stealth: 0	Murder: 4
Hacking: 0	Artistry: 0
Hardware: 0	Nonsense: 0

**Lousy Gangster:** This no-goodnik from the hood has a bandanna, a wife beater, and a lead pipe. He likes doing drugs, snatching purses, and beating up hookers. He never finished school, and he has no combat experience, but he thinks he's hard as hell. Maybe go a little gentle on him as you're beating him to a pulp. Maybe one day he'll thank you.

Perception: 0	Grit: 4
Acting: 0	Athletics: 5
Stealth: 0	Murder: 5
Hacking: 0	Artistry: -1
Hardware: 0	Nonsense: 0

Suggested Items
Bike Chain
Atlas Protection Vest

**Small Child:** This is a small child, aged between four and nine. During this period of their lives, children know very little and have incredibly bad attitudes—therefore, they love to fight and will probably punch you in the balls, try to steal your guns, or tear up all your stuff. They will also ask if you have games on your phone and if you say yes will immediately begin sneezing and chewing on it. Consider all children to be extremely hostile unless proven otherwise.

Perception: 0	Grit: 0
Acting: 0	Athletics: 6
Stealth: 0	Murder: 6
Hacking: 0	Artistry: 0
Hardware: 0	Nonsense: 0

Suggested Items
S&W Sawed-off Shotgun
Bike Chain
Rock
Shiv

## 1 Point Enemies: Use a Little Caution for These.

**Bodyguard:** What every rent-a-cop aspires to be: better-trained, better-equipped, and better-paid. Every so often, one of these guys will go nutshit crazy and embark on a one-man murder spree that leaves dozens dead and burns most of a major city to the ground—but you *probably* don't need to worry about that. It's the exception, not the rule.

Perception: 4	Grit: 6	Suggested Items
Acting: 4	Athletics: 6	S&W Wasp-Sting Pistol
Stealth: 0	Murder: 6	Kessler Munitions Boomstick
Hacking: -1	Artistry: 0	Kapricorn Frontline Blade
Hardware: -1	Nonsense: 0	Atlas Protection Vest

**Police Sergeant:** The one responsible for keeping the rest of the cops in line, the sergeants are part team leader, and part cheerleader. Carrying heavier armaments than her subordinates, the sergeant is capable enough as a fighter, but her real strength is in the simple commands she can issue to her squaddies to increase their fighting prowess.

Perception: 5	Grit: 6	Suggested Items
Acting: 5	Athletics: 7	Black Stallion Assault Rifle
Stealth: -1	Murder: 7	Combat Focusing (In a can)
Hacking: -1	Artistry: 0	Haste (In a can)
Hardware: -1	Nonsense: 0	Atlas Protection Vest

**Assault Specialist:** The assault is the first one in the door, and the last thing many criminals ever see. The assault specialist is faster than broadband and kicks like a double-barrel—which, incidentally, is something they love pointing at you. Standard procedure for assault specialists is to saturate your position with grenades, then while you're disoriented run up and shoot you in the face with a shotgun. Fortunately they only wear light armor, as an occupational requirement.

Perception: 0	Grit: 4	Suggested Items
Acting: 6	Athletics: 8	Thunderbolt Killswitch-20
Stealth: 0	Murder: 8	Thunderbolt Assault Shotgun
Hacking: -1	Artistry: 0	Barrier (In a can)
Hardware: 0	Nonsense: 0	Kessler Whizpop Grenades
		Atlas Protection Vest

**Marksman:** Marksmen are tactical enemies, who work best when the situation can be controlled reasonably well. During a number of highly volatile situations, a marksman is almost required for success—you'll never see the SPD tackle a hostage, siege, or SWAT situation without one. Armed with scout rifles—or the occasional G30, when things get really serious—and trained to shoot for the heart, these are all the reason you need to stay in close quarters.

Perception: 8	Grit: 0	Suggested Items
Acting: 0	Athletics: 5	LunaSea Scout Rifle
Stealth: 0	Murder: 10	Atlas Protection Vest
Hacking: 0	Artistry: 0	
Hardware: 0	Nonsense: 0	

**Technician:** The technician is an indirect combatant, who supports the others with an array of basic cyberwarfare tools, and a wide variety of nonlethal grenades and gadgets. Able to erect walls, disable firearms, and cut off lines of sight, technicians are ideal in many siege situations, but largely ineffective in direct combat or by themselves.

Perception: 0	Grit: 0
Acting: 0	Athletics: 6
Stealth: 0	Murder: 4
Hacking: 7	Artistry: 0
Hardware: 7	Nonsense: 0

Suggested Items
Atlas Portable Wall
Corptechs CLOP
Kessler Whizpop Grenade
APSF Smoke Grenade
Midnight Road Blacktop-5

**Mobster:** You know the mobstah. Of course you do. He's a godfella, a made man, a wise guy. He's a little smarter than them average low-ball gangstas from the last section, and carry some bigger shooters too—the kind what's automatic, and makes big holes in the people when you shoots em. To put it simply, they're real good standard bad guys for all your gang violence needs.

Perception: 5	Grit: 7
Acting: 0	Athletics: 5
Stealth: 0	Murder: 7
Hacking: 0	Artistry: 0
Hardware: 0	Nonsense: 0

Suggested Items
Kessler Munitions OM2
Atlas Protection Vest
Kessler Whizpop Grenade
APSF Smoke Grenade
Midnight Road Blacktop-5

**Huge Thug:** There's guys like these on both sides of the law, and every facet of said sides: huge guys, with riot armor and scary face masks. They have tattoos on all ten knuckles, augments in at least four limbs, and their idea of a good night out is going out and beating up faggots. They have names like "tiny" or "princess", and can't wait to knock your teeth clean out of your head.

Perception: 0	Grit: 8
Acting: 0	Athletics: 8
Stealth: 0	Murder: 8
Hacking: 0	Artistry: 0
Hardware: 0	Nonsense: 0

Suggested Items
Atlas Juggernaut Jacket
Kapricorn Longsword
Thunderbolt Assault Shotgun
Captain-Pattern Ballistic Shield

**Tagger:** The tagger is a reedy noodle-armed vandal, with ill-fitting clothes and a fervent hatred for THE SYSTEM. His clothes are all too loose, he never ties his shoes right, and he dyes his hair green and styles into spikes. But, don't let their garish appearance and frail forms fool you: the tagger is a dangerous enemy. They are swift, and inventive; and most frightfully of all, they carry the awesome power of spraypaint and stencils, with which they can at any moment unleash a torrent of rampant bone-crushing ink! Be careful: they're malcontents under pressure.

Perception: 0	Grit: 8
Acting: 0	Athletics: 8
Stealth: 0	Murder: 8
Hacking: 0	Artistry: 0
Hardware: 0	Nonsense: 0

Suggested Items
Peel
Yank
Barrier

**Back-Alley Doctor:** No, before you ask, she's not a "real" doctor—she lost her medical license over this little scandal in Gstaad, but that's old news you don't want to hear about that. What you need to know is that she's got some pills you'll need to take, and you also need to bite down on this while she glues your leg back on. Also, don't cry so much, and try not to bleed on her when she cuts you open. Look, she never said that she had a great bedside manner.

Perception: 0	Grit: 6
Acting: 6	Athletics: 6
Stealth: 0	Murder: 0
Hacking: 0	Artistry: 0
Hardware: 0	Nonsense: 0
Field Medic: 6	

Suggested Items
Bottle of Painkillers
Mayfly Repeater

**Pickpocket:** From the earliest days of London town to the most insufferably modern metropolis, pickpockets roam in hordes. These smelly, penny-snatching, good-for-nothings love to snatch purses and burgle homes—but more than anything, they love to strike while the iron is hot. While their big friends distract you, the pickpocket will knock you over the head and steal your stuff!

Perception: 0	Grit: 8
Acting: 0	Athletics: 8
Stealth: 0	Murder: 8
Hacking: 0	Artistry: 0
Hardware: 0	Nonsense: 0

Suggested Items
Blackjack
Yank (In a Can)
Shortbow (And Knockout Arrows)

**Pyromaniac:** The pyromaniac has never seen a problem that couldn't be solved with fire. This includes things like home improvement, taxes, cancer, neighbors, and most importantly...you!

Perception: 0	Grit: 8
Acting: 0	Athletics: 6
Stealth: 0	Murder: 6
Hacking: 0	Artistry: 0
Hardware: 0	Nonsense: 0

Suggested Items
Molotov Cocktail
Kessler Munitions Flamespitter

**Bull-Rushing Idiot:** There's not much to this guy, and that's probably for the best. He's loud, vulgar, smelly, and terribly uneducated; and he is fond (To a nearly fetishistic degree) of running away from his friends and crashing directly into the enemy lines come what may. All of the gangsters, policemen, soldiers, and what-have-you of the Doublearth know someone like this; and generally, they're happy to let him do what he will. It's less work for the rest of them.

Perception: 0	Grit: 10
Acting: 0	Athletics: 8
Stealth: 0	Murder: 6
Hacking: 0	Artistry: 0
Hardware: 0	Nonsense: 0

Suggested Items
Shieldscale Ind. Blast Shell
Captain-Pattern Ballistic Shield
Longsword
Thunderbolt Assault Shotgun
Atlas Juggernaut Jacket

## 2 Point Enemies: Get Ready to Break a Sweat!

**SWAT Officer:** When the situation gets too hot for the normal police to handle, it's time to call in the SWAT officers. With their special weapons and superior training, SWAT officers can assault fortified positions, and move around and against even hardened paramilitary threats. Anyone going against a team of SWAT agents should move with particular care—if only because their defeat harkens the arrival of something significantly more dangerous...

Perception: 5	Grit: 6	Suggested Items	
Acting: 3	Athletics: 6	Kessler Munitions OM2	
Stealth: 0	Murder: 9	Atlas Heavy Impact jacket	
Hacking: 0	Artistry: 0	Operator's Pistol	
Hardware: 0	Nonsense: 0		

**Ninja:** I don't believe in ninjas. I've never seen one, at least. Nor have you, I'd wager. You probably don't need to worry about this enemy profile.

Perception: 5	Grit: 4	Suggested Items		Suggested Augments	
Acting: 0	Athletics: 10	Garrote Wire		Technicular Dreamcoat	
Stealth: 10	Murder: 5	APSF Smoke Grenade		APSF Skunkspray	
Hacking: 0	Artistry: 0	Lightboom Grenade			
Hardware: 0	Nonsense: 0	Atlas Compound bow			
		Operator's Helm			

**Elite Soldier:** When things are spiraling out of control and the normal forces just can't handle it, it's time to call in the very best of the best. Picked from the ranks of decorated combat veterans, the elite soldiers carry a devastating array of weapons and armor, and know how to use all of it. Augmented, outfitted, and trained for the most dangerous cyberpunks of all, these powerful elites will strike you stone-dead soon as look at you. Watch the fuck out.

Perception: 0	Grit: 10	Suggested Items		Suggested Augments	
Acting: 0	Athletics: 10	Redstone APL		Twin Suns Compensatory Cuffs	
Stealth: 0	Murder: 10	TSD Hurricane Machine Gun		Titanio Body Shield	
Hacking: 0	Artistry: 0	Atlas Ulysses Protection Suit		Hexagon-2 Shielding Unit	
Hardware: 0	Nonsense: 0	Operator's Helmet			
		Sawed-Off Shotgun			

**Caricaturist:** A set of colored pencils and a drawing pad is all it takes to turn the caricaturist into a violent force of chaos: able to whip up dozens of doodles in rapid succession, the caricaturist uses his limited item selection to great effect in tandem with his ink.

Perception: 6	Grit: 6	Suggested Items			
Acting: 4	Athletics: 7	Fake Wall		Outflow Improvement Vest	
Stealth: 0	Murder: 0	Combat Focusing		Basic Cognitive Enhancer	
Hacking: 0	Artistry: 10	Obfuscation		Peel	
Hardware: 0	Nonsense: 0	Horrible Image		Mass Peel	
		Haste		Lift	

**Combat Medic:** Wee-woo, wee-woo! Here comes the one-man ambulance! The combat medic might not be big and tough like all his friends, but the others all know that he's the one who holds the team together! The combat medic has the medical supplies and know-how to stitch his team back together even after the worst of scrapes, and wears a suit of armor that's thick enough to keep him safe but light enough to keep him moving. While you technically *can* shoot this guy, that's a war crime. And that makes you a dick.

Perception: 6	Grit: 6	Suggested Items	Suggested Augments:
Acting: 8	Athletics: 8	Atlas Heavy Impact Jacket	Technicular Dreamcoat
Stealth: 6	Murder: 0	DivSys Stem Cell Sprayer Mk 1	Archon Rabbit
Hacking: 0	Artistry: 0	Bottle of Painkillers	
Hardware: 0	Nonsense: 0	S&W Mayfly (For Freezing)	
Field Medic: 10	Surgery: 6	Mediquick Splinting Kit	
		Mediquick Nanobiotic Shot	

**Sniper:** The sniper is very much unlike her companions. She is not just a crazed gunman: she is a professional—efficient, and prepared. Asserting herself at a convenient elevated position, she keeps both full-blown sniper rifles for lengthy vigils, and a smaller marksman rifle for mobile engagements. Not only is she accurate, she is keenly perceptive—making her a great lookout, who will keep the rest of her unit safe from the clutches of acquisitive punks.

Perception: 8	Grit: 0	Suggested Items	Suggested Augments
Acting: 0	Athletics: 8	Thunderbolt G30 Sniper Rifle	Archon Enterprises Spider
Stealth: 8	Murder: 10	Thunderbolt Bullhammer Rifle	Delphi Targeting Augment
Hacking: 0	Artistry: 0	S&W Selleck Magnum Revolver	S&W Acesleeve Ballistic Kit
		Olympus Thermal Glasses	Peeping Tim +

**SysAdmin:** Whenever a hacker begins wreaking havoc on a secured system, it's time to call in the SysAdmin. This codeslinging keyboard warrior can't pop off shots or shrug off wounds, but what he can do is manipulate an entire battlefield with his pocket computer and gadgets. If the worst comes to pass, he can put up some token resistance with his self-aiming pistol.

Perception: 4	Grit: 2	Suggested Items	
Acting: 4	Athletics: 4	Midnight Road Blacktop	Atlas Protection Vest
Stealth: 0	Murder: 0	CSC Comdom	Ballistic Armor Repair Kit
Hacking: 10	Artistry: 0	No.exe	Jack/Hammer
Hardware: 8	Nonsense: 0	Mindhack.exe	Portable Wall
		UA Wunderpistol	CorpTechs CLOP (& Grenades)

**Commandant:** Stern, stalwart, and steely-eyed, the commandant is the Greatcoat-clad hero of the people, and the blue-blooded captain of the constabulary, and the scowling bloody-eyed fist of the Acceptable Culture ministry—depending on what job he's working that day. Well-armed, long-suffering, and ready to lead his men to death or glory, the commandant is a high-priority target capable of punishing lawbreakers and rallying his allies.

Perception: 0	Grit: 9	Suggested Items	
Acting: 8	Athletics: 8	Thunderbolt Expressway Rifle	Kessler Munitions GL41
Stealth: 0	Murder: 9	Atlas Juggernaut Jacket	Lightboom Grenades
Hacking: 0	Artistry: 0	Radial Barrier (In a Can)	Combat Focusing (In a Can)
Hardware: 0	Nonsense: 0	S&W Selleck Magnum Revolver	ASPF Zip Ties
Bossyboots: 8		Meltdown Grenade (Handle with care, this kills players.)	



## The Doublearth at a Glance: Ideas for Your Own Stories

This section of the book is a little different from the others: it's not an explanation of rules or concepts like the rest, but rather a series of fictional staples and pre-assembled narrative devices for easy reference. For players, these can be sources of flavor, motivation, or history; and for the GM, these are ready-made enemies and plot points. As we mentioned waaaaaaaaay back in the introduction, the stuff you'll find here is broad-strokes material—if you want something with a little more depth to it, though, you can find enemies, heists, and entire factions pre-baked and ready for use at Toonpunk-game.com.

### Why is it Called the Doublearth?!

Because there's two of the planet Earth orbiting each other in close proximity and they're connected by a giant space elevator. Obviously that's physically impossible but...come on, you've made it this far, you know what my answer's gonna be. Just figure out something to do with it.

### Gangs!

A staple of criminal fiction is the rival gangster, and for good reason: not only are they likely to have valuable contraband, the players can shoot at them without the soul-destroying guilt inherent in the mass-murder of police officers. GMs should consider using thugs, extortionists, drug dealers, pimps, and so on as enemies in the early parts of a campaign—especially because in more cynical stories, gang shootouts can conceivably go unnoticed by police responders. Players, meanwhile, will find gangs to be valuable allies—and they could even start one of their own!

### Evil Corporations!

Statistically speaking, you're probably not the head of a multi-national corporation, and odds are you and all of your friends got a proverbial skullfucking during the most recent economic crash—whenever that may have been, at time of reading. So, who better to steal from now than the ones who stole from all of you then? Evil corporations are great enemies for the players to overcome, and great motivations for their criminal ambitions—punks who were impoverished by the greed and cruelty of a corrupt executive are as driven as they come!

### Mercenaries!

If mega-corporations are evil, and the most evil kind of corporation are mercenary companies, then mercenary mega-corporations are *double* evil! Some kind of international private army is a great idea for high-end enemies, of the kind that show up when raiding banks and research labs—and it's also a ready-made excuse for player characters to have firearms experience and tactical training.

### Racism!

Nazis, klansmen, skinhead bikers—all these and more are great adventure material. You could use upheaval and tension as a backdrop for a campaign; or perhaps a character can be motivated by some act of hatred committed against them! In the world of toonpunk, there's plenty of things to be prejudiced against people for—skin color, species, augmentation, homepage, and a whole host of other things you can just make up!

### Foreigners!

Alternatively, if you yourself are a racist, you can have the enemies be foreigners, minorities, or whatever else it is that sticks in your craw!

### Mutants!

No, not the cool kind of mutants that shoot lasers out of their eyes—the horrifying nearly-dead kind of mutants that have searing boils all over their skin and defecate radioactive ooze. These poor things usually show up in the aftermath of a nuclear accident or a toxic waste spill; and can, depending on the nature of the campaign, be pain-maddened swarms of man-eating monstrosities, or tragically misunderstood victims of a horrible misfortune.

### Androids!

Are you human? Are all your *friends* human? Does it really matter? In many science-fiction adventures—the Doublearth included—machines are so advanced that they can expertly emulate living things. Sometimes, this is a powerful force for good: androids, living in harmony with their creators, can revolutionize menial labor, high-risk jobs, combat, space travel, and numerous other things for the mutual benefit of everyone! However, errant

programming, or twisted machine logic, could be the first step to an earth-shaking robot uprising!

## Clones!

Are all your friends who they say they are? Probably. But if your friend dies in an accident and someone makes an exact duplicate of them with all their memories and personality, did they die in any meaningful capacity? There's something to think about.

## Doomsday cults!

If you ever need an army of inexplicably well-funded goons who are hell-bent on destroying the world as we know it, why not involve some kind of weird religion? Perhaps a group of society elite cultists that worship bug-men from Mars, or uneducated hooligans who pay homage to Cthulhu—and how much do we *really* know about the Mormons, now that I think about it? GMs should consider having the players go up against a cult of some kind—or, for a new and different twist, have them be part of one, in a quest to end the world as we know it!

## Nanomachines!

Nanotechnology is more than just a miracle of science: it's all-purpose plot insulation! Any time you need to explain something that doesn't make a whole lot of sense—whether it's an enemy developing superpowers, or the players never needing to eat, or doodles in non-doubleearth settings, you can always just wave your hands and say “nanomachines”!

## Conspiracies!

The conspiracy is the bread and butter of cyberpunk dystopian fiction: from the early days of Richard Condon to the aftermath of 9/11, nothing lends tension and danger to your proceedings quite like a conspiracy. This is because conspiracy fiction, despite what some people would have you believe, is the easiest thing in the world to write.

All you need to do is invent some kind of horrible tragedy that kills a lot of people (such as a plague, terrorist attack, train crash, bomb detonation, etc) and then come up with a really convoluted chain of reasoning that explains why it's somebody's fault. Obscure this information behind disposable characters, patchy phone calls, grainy photographs, and whatever else you can think of that only reveals information piecemeal; and continue doing so until the story makes no goddamn sense until you're 75% through with it. You may wish to imbibe mind-altering substances to help this.

Then, position the players on either side of said disaster—either trying to keep it from happening, or in the immediate aftermath thereof—and let 'er rip. Some sample conspiracies are included here for your use:

**A conglomerate of augmentation manufacturers** want to drive up sales, so they engineer and unleash a plague that only affects people who are 100% biological and ignores cyborgs.

**A corrupt real estate tycoon** wants to purchase and renovate large amounts of urban living space, and finances a large gang war to drive property values down.

**An internationally popular religion** discovers that their messiah is real and strongly disapproves of them, so they lock said messiah in a third-world prison while simultaneously funding a radical movement from whichever faith they like the least, in order to drive up membership.

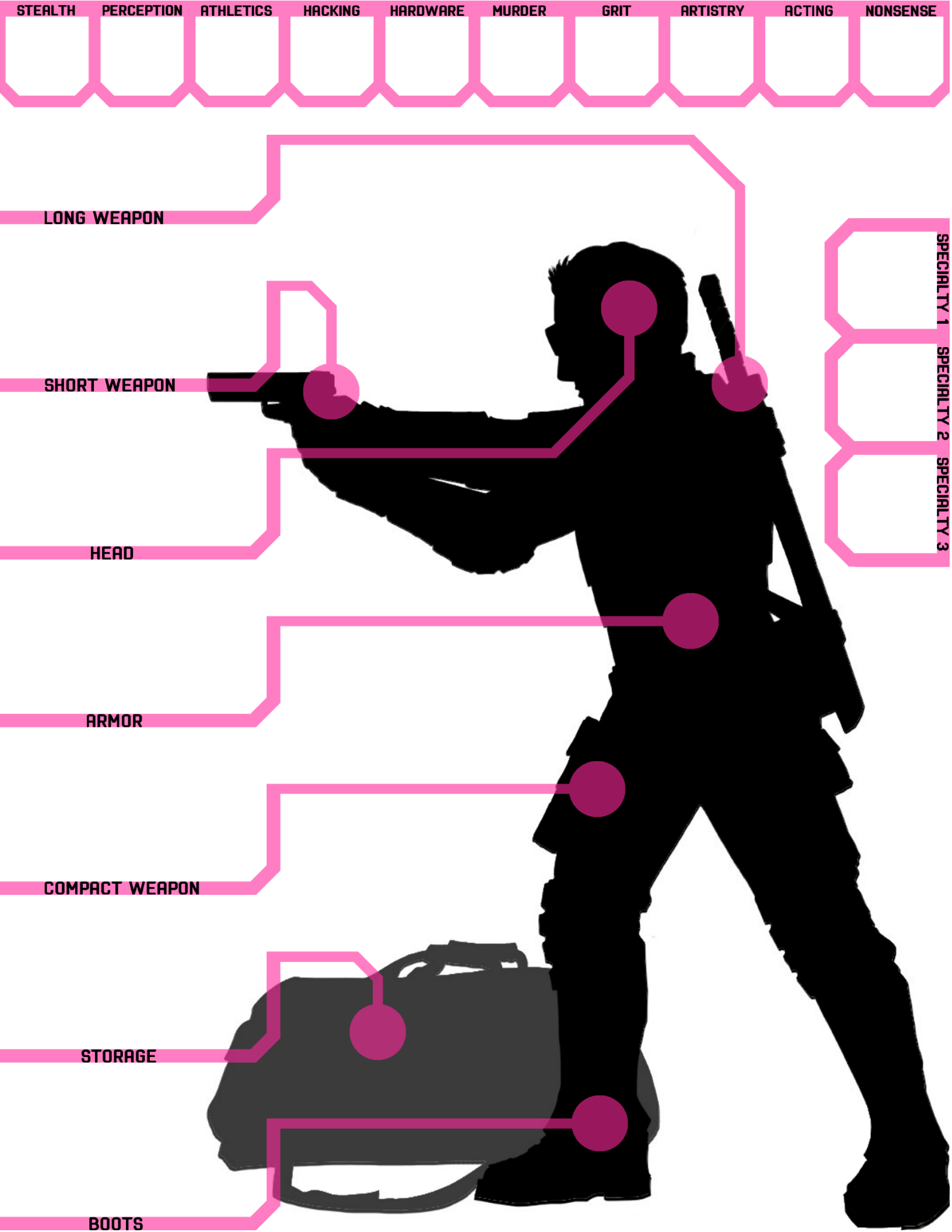

①  
5

NAME | CODENAME

NECK | EXTERNAL

SKULL | EXTERNAL

BACK | EXTERNAL

NECK | SUBDERMAL

SKULL | SUBDERMAL

BACK | SUBDERMAL

ARMS | EXTERNAL

CHEST | EXTERNAL

ARMS | SUBDERMAL

CHEST | SUBDERMAL

LEGS | EXTERNAL

WAIST | EXTERNAL

LEGS | SUBDERMAL  
GLOBAL AUGMENTS

WAIST | SUBDERMAL  
SPECIAL AUGMENTS

SPECIES

