

STARSHIPS & SPACEMEN 2E

CONFLUX

MISSIONS: #1 - #5



AN ASHDOWN ADVENTURE

LUMINOUS DESIGN

CONTENTS - CREDITS

Introduction	02
Campaign	02
Notations	02
Terminology	03
The Region	03
Engage...	04
The Starship Lockley	04
The Lockley's Vagaries	05
The Missing Shuttle	07
The Ship's Stores	07
#1: "Containment"	08
#2: "Delta-Orconis"	16
#3: "The Derelict"	25
#4: "Distress Call"	33
#5: "Missing Persons"	41

This fan created product is designed for use with Goblinoid Games' Starships & Spacemen™ 2nd Edition role playing game, which can be found at www.goblinoidgames.com. Starships and Spacemen™, and associated content owned by Daniel Proctor and Goblinoid Games.

AUTHOR & ILLUSTRATOR:

Scott Mulder (Luminous Design Studio)

CGI MODELS & TEXTURES:

Richard Merk, Simon Schild, Power Fusion 3-D, 3-D-C, Notilize, Coflek Gnorg, Adam Thwaites, Cybertenko, Uzilite, Darriofish, Predatron 3D, Nightshift3D, The Antfarm, Mortem Vetus, Xena, April YSH, Ian Palmer, Petipet, Mylochka, and Valander.

This product contains fan created content under the creative common license. The purchaser of this product may re-print it for personal use.

ARTWORK:

Copy Right 2020. All original or derived artwork contained in this product were created by Scott Mulder and Luminous Design Studio. These works cannot be redistributed or extracted outside the personal use of this product without the expressed written permission of the artist.

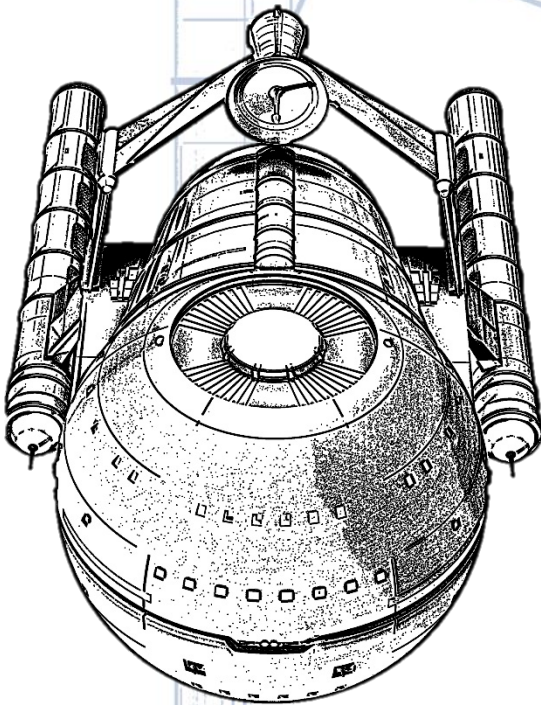

INTRO

Conflux is a continuing series of interconnected one-shot episodic adventures for use with Goblinoid Games' Starships and Spacemen 2nd Edition Role Playing Game. This supplement is intended for beginner to intermediate Player-Characters ranked Levels 1-5. The mission scenarios contained herein are written for the Ashdown Campaign Universe but may be used with the original game campaign setting with some adjustments. Luminous Design Studio's resource supplements "Ashdown: Sol & Xoth Sectors" and the "Starship Construction Manual, Vol's #1 & #2" are highly recommended for use with this product but are not required. You can use this module as written or as inspiration for use in adventures within your own game setting.

CAMPAIGN

This resource supplement takes place within Luminous Design Studio's Ashdown Campaign Universe. This campaign setting is a fictional alternate reality in the year 2290 loosely based on factual and fictional places in our own universe. There are some differences between this game setting and the original one found in the 2nd Edition Rulebook published by Goblinoid Games. One specific distinction is that in the Ashdown Universe the Gorrans have an

independent interstellar government and are not members of the Galactic Confederation. Space Masters who wish to keep the Gorrans as written in the 2nd Edition Rulebook can simply articulate that the Gorrans home-world is the Confederation's foothold in the Beta Quadrant. This campaign universe is composed of the two charted quadrants of the known galaxy (Alpha and Beta) and two uncharted ones (Gamma and Delta). Space Masters can introduce the PC's to this alternate reality as their home setting or find their way here through a teleporter mishap, alien portal, or dimensional rift.

NOTATIONS

Throughout this adventure module you will see a numeric reference, for example (*Planet #01*), annotated next to the names of planets and (*Star #01*) next to the names of solar systems. This notation number corresponds directly to the assigned reference number for these places in the Luminous Design Campaign Resource "Ashdown: Sol & Xoth Sectors".

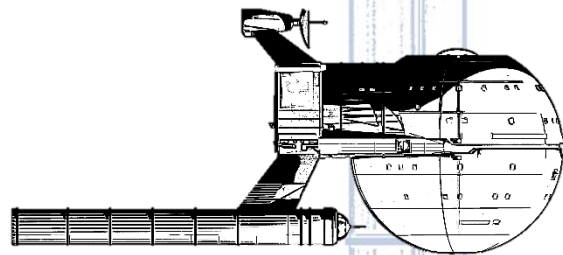

TERMS

ABBR.	GAME TERMINOLOGY
AR	Armor / Armor Rating
BB	Beam Bank
CHA	Charisma
CMD	Command
CNT	Contact
CON	Constitution
CSF	Confederation Space Fleet
DEX	Dexterity
ENG	Engineer / Engineering
ENL	Enlisted
EQ	Equipment
FC	Fire Control
HP	Hit Points
INT	Intelligence
MIL	Military Branch
MED	Medical
OFC	Officer
PC's	Player Characters
PPB	Power Pile Base
PSI	Psionic Potential
NAV	Navigation
NPC's	Non-Player Characters
SCI	Science Branch
SEC	Security
SIB	Space Fleet Intelligence Bureau
SL	Sentient Life
SM	Space Master
SUB	Sub Class
STR	Strength
SS	Shuttle Ship
S&S	Starships & Spacemen RPG
TEC	Technical Branch
TELE	Teleporter
TORP	Torpedo / Ion Torpedo
XP	Experience Points
ZSF	Zangid (Imperial) Space Force

THE REGION

The region of the Ashdown Campaign Universe's Galactic Map that is used in this adventure supplement is known as the Sol Sector. This sector is located in the Alpha Quadrant of charted space and is the home of the Galactic Confederation of Allied Worlds.

REGIONAL STAR SYSTEMS				
#	Quad.	Sect.	System	Planets
01	Alpha	Sol	Sol	10
02	Alpha	Sol	A. Centauri	4
03	Alpha	Sol	P. Centauri	2
04	Alpha	Sol	Sirius	3
05	Alpha	Sol	E. Eridani	4
06	Alpha	Sol	Tau Ceti	5
07	Alpha	Sol	Vega	11
08	Alpha	Sol	40 Eridani	5
09	Alpha	Sol	Demai	5
10	Alpha	Sol	Z. Herculi	7
A1	Alpha	Sol	Unexplored	15
A2	Alpha	Sol	Unexplored	4
A3	Alpha	Sol	Unexplored	9
A4	Alpha	Sol	Unexplored	6

- The unexplored systems listed above (A1 - A4) are known as the "Forbidden Stars" in the Ashdown Universe. They are inaccessible to normal space travel due to dangerous or unpredictable navigation hazards.

ENGAGE. . .

The starting point for this series of interconnected mini adventures is on Starbase Alpha orbiting the planet Earth in the Sol Sector. The player characters (All Confederation Officers or Enlisted Spacemen) are visiting this vital Starbase either on official Space Fleet business or for personal reasons. While attending to their affairs the PC's are suddenly surprised with an urgent alert on their communicators with new orders to report immediately to the C.S.F. Lockley for duty assignment. The new orders, sent from Starbase Alpha's Admiral Amano, indicate that the PC's have been selected as temporary replacement crew at the request of Captain Isaiah Watts. Strangely, the PC's have never heard of Captain Watts and have no idea why he would personally select them to crew his ship.

SPACE MASTER: *Regardless of rank or experience the PC's can assume any second-tier duty stations matching their Space Fleet career path. All command level and first-tier positions are currently occupied by NPC incumbent officers or enlisted crew. These duty station positions may become available for the PC's to fill later in future mission scenarios.*

THE STARSHIP LOCKLEY

The Galactic Confederation Starship C.S.F. Lockley was named after the 22nd Century deep space explorer Holden Lockley who piloted the United Earth Government (UEG) prototype matter/antimatter powered exploration probe "Destiny-3". The C.S.F. Lockley is an older model Pytheas Class Exploration Starship (Equivalent in size and capabilities to a Destroyer) that entered Space Fleet service in 2258 as a dedicated science and planetary survey vessel. The ship's sturdy construction, minimal support requirements, and prolific record as a deep space explorer has contributed to its longevity within the fleet. Affectionately nick-named "The Lock-Knee" by its crew as a not so subtle reference to the ship's advanced age. The Lockley has under-gone three refits to date and is unfortunately now nearing the end of its service career. The ship is currently scheduled for decommission and stand down at the end of its current mission cycle in ten months.

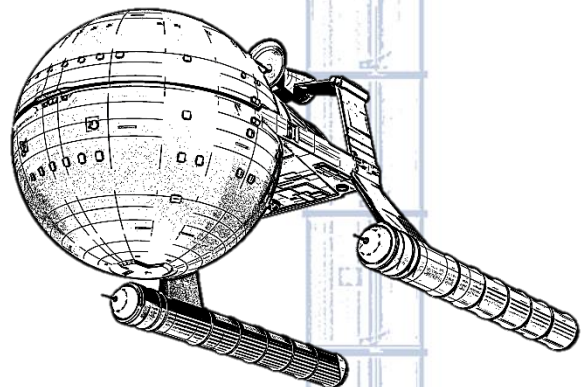

C.S.F. LOCKLEY		
Ship's Name:	C.S.F. Lockley	
Ship Type:	Explorer	
Ship Class:	Pytheas Class	
Designation:	EX-047	
Commissioned:	2258	
Affiliation:	Confederation	
Crew Compliment:	20/200	
Command Rank:	Lieutenant	
Hull Size:	3	
Mission Duration:	3 Year Cycle	
Construction Cost:	130 CP	
Power Pile Base:	120 (2x ½ Pods)	
Habitable Decks:	16	
Teleporter Cap:	4 At A Time	
Beam Banks:	2	
Ion Torpedoes:	8	
Shuttle Ships:	1 (Capacity 2)	
Sick Bay Cap:	5 At A Time	
Cryo-Tubes:	6	
Ship's Locker:	10	4

THE LOCKLEY'S VAGARIES

As an older starship, the normally tolerable flaws found on similar vessels, are considerably more conspicuous on the Lockley. Included here is a description of the four most noticeable quirky faults and flaws found on the Lockley.

1. The Lockley has a faulty hyperspace harmonics induction coil which causes the ship to noticeably shake every time it enters hyperwarp. Each hyperwarp factor above 2 increases the intensity of the

vibration causing a -1 penalty per H-factor for any physical action requiring an attribute or skill check.

2. A poorly networked data connection in the Lockley's helm control delays all bridge commands to the engine room to engage hyperwarp by 1d6 rounds. Sometimes it is just faster to call in commands to the engine room by hand-held communicator than to wait for the helm console.

3. A defect in the Lockley's central computer core results in an awkwardly long processing pause lasting 2d10 rounds each time an inquiry is made to the ship's computer.

4. The shoddy installation of the ship's food processing units results in a constant protein line leak that attracts infestations of Rigellian Space Lice. (S&S-2E, Pg. #16) The infestation is nearly impossible to contain as the pesky bugs simply relocate through the mechanical crawl spaces when faced with eradication. Every day while in transit the Space Master should roll 2d8 to determine what deck will experience the next outbreak. During the outbreak crew members may randomly encounter 2d4 Space Lice during the infestation. The infestation on each deck usually lasts 24 hours while the ship's robot eradicates the pests to a point where they move to another deck.

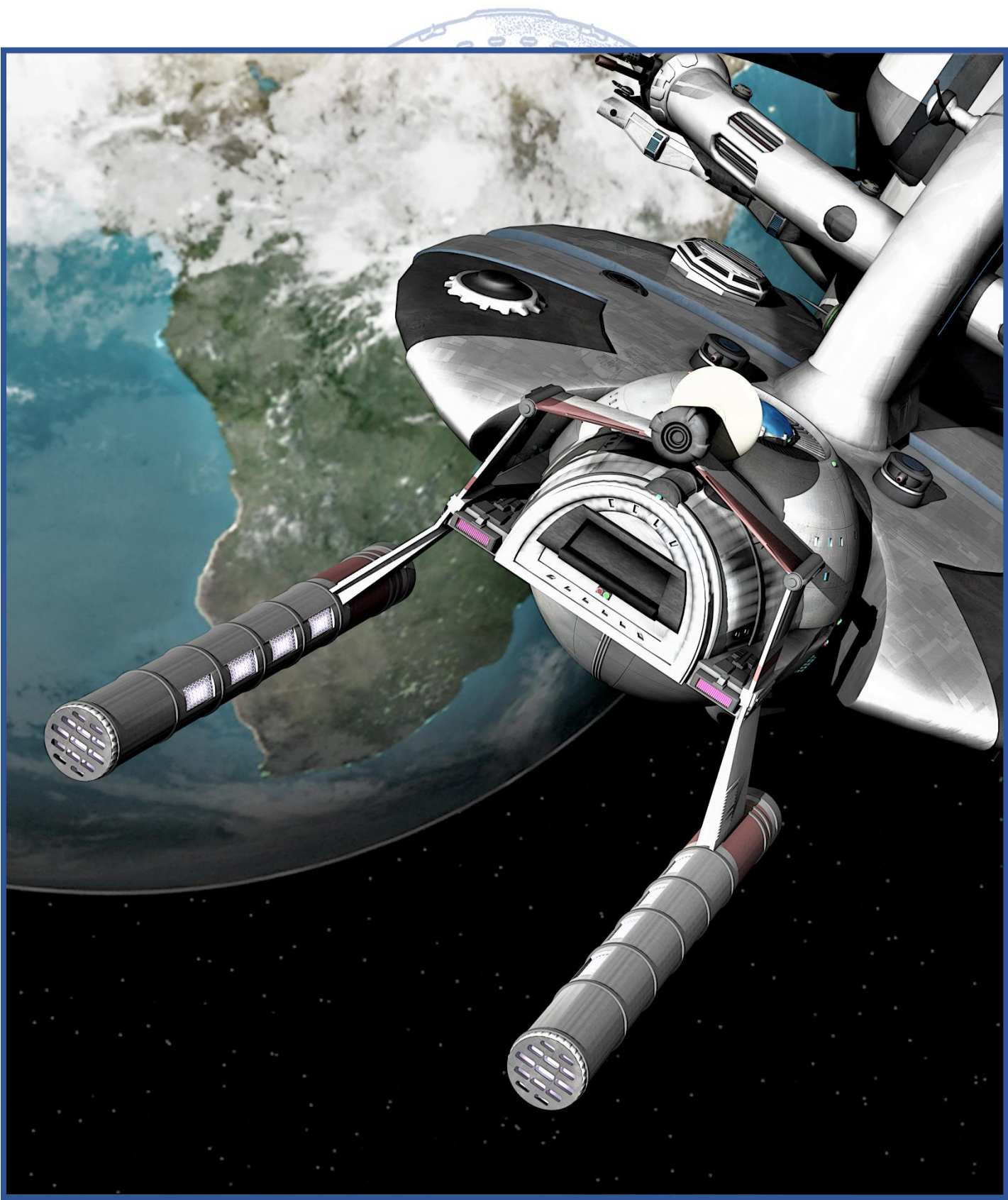

MISSING SHUTTLE

The C.S.F. Lockley can support up to two shuttle ships but currently only has one. The second shuttle ship was recently lost in a mysterious cosmic gas cloud (S&S-2E: Pg. #31) and is the reason why Captain Watts needed last-minute crew replacements for his ship. Rumors have it that Captain Watts was deeply traumatized by the event and has not yet requisitioned a replacement shuttle because he holds out hope that his lost shuttle and crew might be found. Whenever, the matter is mentioned the Captain is known to change the subject or end the conversation abruptly with a less than courteous dismissal.

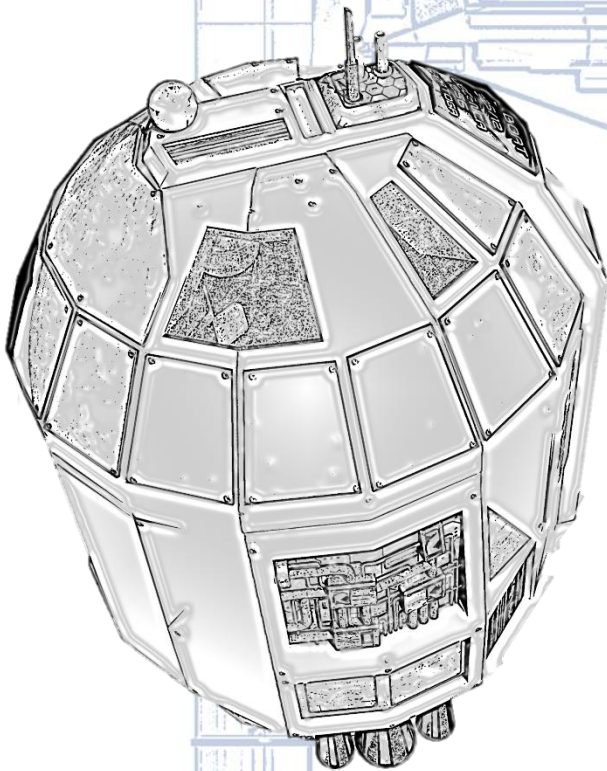

THE SHIP'S STORES

The Lockley's equipment storage facility is located on Deck-6 (Room #31) near the main cargo bay. This compartment remains locked at all times and is only accessible with an Officer's authentication code.

C.S.F. LOCKLEY'S SHIP STORES	
QTY.	EQUIPMENT ITEM
5	Beam Pistol
5	Electro-Stun Gun
3	Medical Kit
2	Auto Analyzer
2	Universal Translator
5	Communicator
2	Data Recorder
5	Radiation Suit
5	Oxygen Tank
1	Planetary Radar Tracking Unit
1	Energy Screen
1	Force Field Generator
2	Sky Cycle
2	Jet Pack
1	Coil 50' Synthetic Rope
2	Maintenance Robot

MISSION #7

“CONTAINMENT?”

This mission is a straight up bug hunt for a pesky infestation of Rigellian Space Lice afflicting the crew of the C.S.F. Lockley. Can the PC's win the respect and appreciation of the Lockley's stoic Captain by eliminating the pests and staying out of sick bay?

ORDERS

While docked at Starbase Alpha for resupply and crew replacements the Lockley receives new orders from Admiral Amano. The C.S.F. Lockley is ordered to proceed to the planet Deneb (*Planet #20*) in the Sirius System (*Star #04*) and deliver a shipment of medical equipment to the local Confederation's space station.

MISSION DETAILS

Eager to complete this routine supply run Captain Watts has set a course from Starbase Alpha to the Sirius System at hyperwarp factor 3. At this rate, the 8.5 light-year journey will take two and a half days of interstellar travel. At this hyperwarp factor the new crew members will experience firsthand one of the Lockley's engineering quirks which is a noticeable persistent vibration of the ship during hyperwarp. At first the vibrations within the ship are very noticeable but

overtime they gradually become less perceptible as the crew becomes acclimated. While traveling at this factor of hyperwarp all crew on the ship will have a -1 penalty to all physical actions requiring an attribute or skill check due to the mild but persistent shaking sensation.

While enroute to Sirius the persistent vibration of the ship at hyperwarp awakens an infestation of Rigellian Space Lice from its current hiding place in the mechanical crawl space. The nasty pests find a suitable food source from a leaking protein supply line inside the Officer's Club food processing unit on Deck-2. With an abundant supply of readily available food, the Space Lice begin to grow and reproduce at a rapid rate. Within hours a new brood of Space Lice emerge from their eggs and join the feast inside the food processor. Crew members using the food processor begin to complain to the Engineering Staff that the food delivered from the unit tastes off. As the protein supply for the processor is eventually consumed by the Space Lice, they begin to search out new food sources on the deck. Throughout the first day of travel Captain Watts begins to receive reports of Space Lice sightings on Deck-2 and four crew members have been sent to Sick Bay suffering from illness after being attacked.



With the outbreak erupting just below the Bridge, Captain Watts orders the evacuation of Deck-2 and establishes a quarantine of the infected crew in Sick Bay. All access points to and from the deck are sealed trapping the Space Lice inside. As new crew members on the ship, Captain Watts feels this would be a perfect opportunity for the PC's to become familiar with their ship and its embarrassingly persistent problem. The PC's are directed to proceed to Deck-2 with the service robot and eradicate the pesky outbreak.

SPACE MASTER: While enroute to Deneb it is recommended that the SM check for random galactic encounters and space hazards as described in the 2nd Edition Rulebook (S&S-2E: Pg. #31 - #35).

EQUIPMENT

The PC's party will be provided with one auto-analyzer device, two communicators, and one electro-stun gun for each member of the party. The PC's are strictly prohibited from using any other kind of weapon during this assignment to prevent potential damage to the ship or accidental injury to the crew. The electro-stun guns deliver a sufficiently lethal shock at short range to kill any Space Lice encountered. The ship's service robot is also equipped with an internally mounted electro-sun gun and has a lot of previous experience eradicating

the nasty beasties. The PC's can use the auto-analyzer or an inquiry to the ship's computer to help locate and track the Space Lice on Deck-2.

SPACE MASTER: Due to the Lockley's third engineering flaw all computer inquiries by the PC's to ascertain the location of the Space Lice will have a 2d10 round delay before the computer responds. The PC's can attempt to interface with the computer at any of the computer terminals on the deck with a successful technical skill roll (S&S-2E, Pg. #46).

DECK-2 / GROUND ZERO:

Deck-2 on the C.S.F. Lockley contains various crew support facilities including the officer's club, mess-hall and crew quarters. The PC's will have to search all rooms on the deck to locate and eradicate the infestation. 2d4 adult space lice will be found in each room on the starboard side of the ship. At between two and four inches long the space lice are easy to locate in the open. However, they often prefer to hide inside containers or under furniture to avoid detection until they can feed on an unsuspecting host.

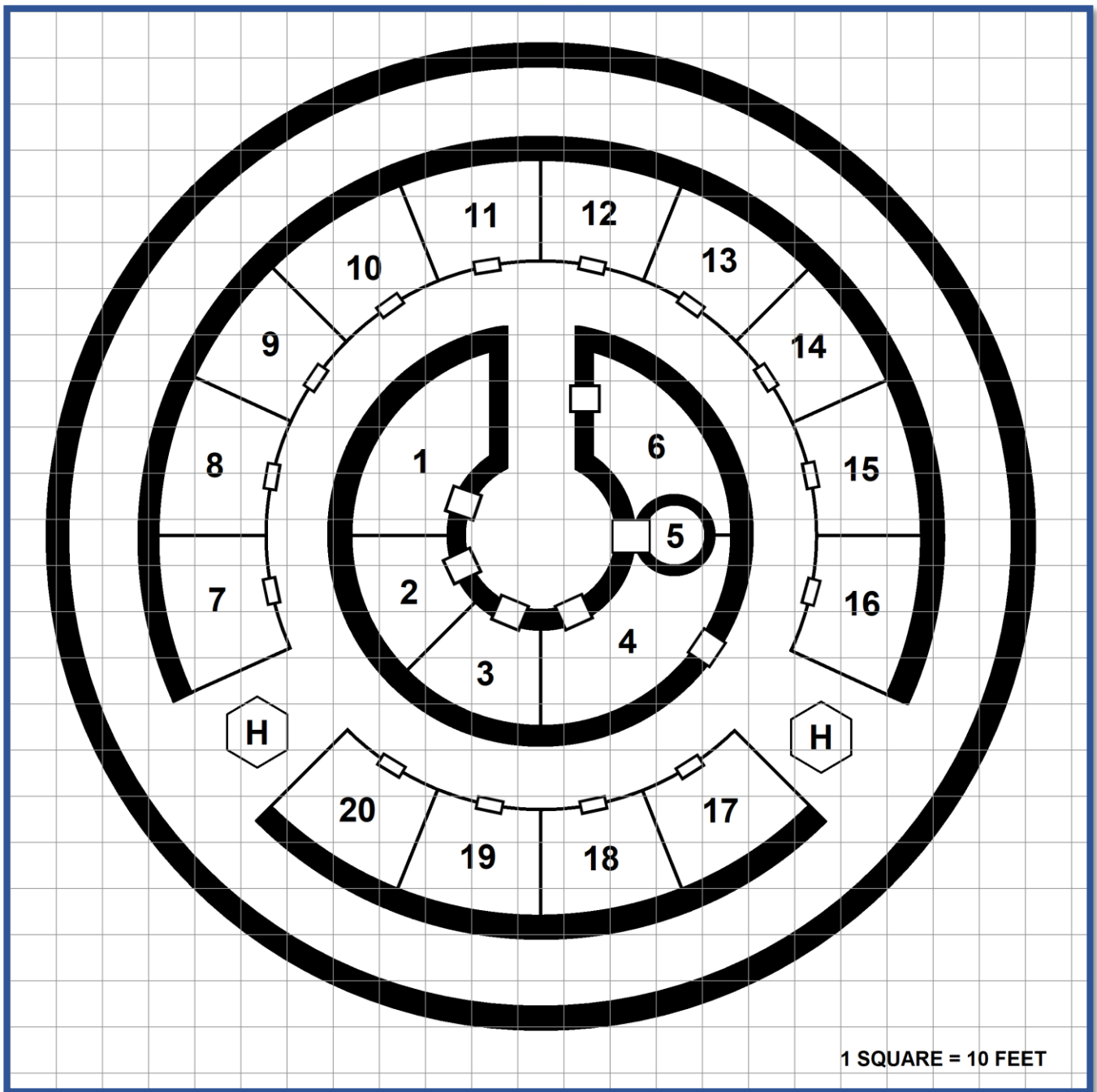

#1 RECREATION ROOM

This room contains an all-purpose recreation area, relaxation lounge, and fitness center for the ship's crew. It is a high traffic area with crew members from all parts of the ship visiting for exercise and relaxation.

#2 COMPUTER LIBRARY

This room contains four computer library stations and access terminals. This facility can be used to interface with the ship's computer core or retrieve information from the computer memory banks.

#3 SUPPLY ROOM

This room is a mechanical maintenance supply room used to store various equipment and tools.

#4 OFFICER'S CLUB

This room contains the officer's lounge and off-duty entertainment facility. Like the recreation room, this compartment is a high traffic area frequented by the ship's Officers and Command Staff.

#5 TRANSIT LIFT

This area contains a lift car station that provides rapid transit between decks.

#6 OFFICER'S MESS

This room contains the officer's kitchen, food processor units, and dining area.

#7 - #16 OFFICER QUARTERS

These rooms are designated as double occupancy junior officer living quarters. They contain a shared lavatory, two beds, and two personal item storage lockers.

(H) PERSONNEL HATCH

This is a restricted access service hatch and ladder-well that provides access between decks.

#17 - #20 VIP QUARTERS

These executive suites are all designated as senior officer living quarters and VIP passenger rooms. They contain a private

lavatory, single bed, personal item storage closet, and private computer terminal.

SPACE MASTER: Rooms #1 - #4 and #12 - #18 on Deck-2 all have infestations of Rigellian Space Lice present in them.

(H) PERSONNEL HATCH

This is a restricted access service hatch and ladder-well that provides access between decks.

MISSION NPC'S

The first NPC's that the characters will come into contact with upon arrival onboard the Lockley in the teleporter room are Captain Watts, acting Chief Engineer Vanlan, and the ship's service robot ED-2 (Engineering Droid 2). All of these NPC's are available to assist the PC's during this mission. In order to successfully complete this mission all NPC's must survive this adventure.

ISAIAH WATTS

Captain Isaiah Watts is a highly decorated 25-year veteran of the Space Fleet Service and the fourth Captain to command the C.S.F. Lockley. His career record has been exemplary but not particularly glamorous or noteworthy. A stoic and intensely private person, Watts is well liked by his crew but not personally well known by them. On a recent mission, Watts lost 14 crew members when their shuttle was

caught in a cosmic gas cloud and the spacecraft was lost. While held blameless in the incident, Watts took the loss exceptionally hard and has been deeply troubled by it since.

SPACE MASTER: *The non-player character Captain Watts was designed to serve as a plot control in the event that the PC's begin to stray too far off the beaten path in the adventure. As the Captain of the Starship Lockley he has final say in all matters and is ultimately responsible for everyone who serves under his command. He is an arbiter, a symbol of authority and the voice of reason when things get out of control.*

CAPTAIN ISAIAH WATTS							
Race: Human		Gender: M		Age: 51			
Class: MIL		Sub: CMD.		Level/Save: 6 (Ofc.)			
HP	STR	CON	DEX	INT	CHA	PSI	AR
39	12	14	12	11	15	03	-2
EQ: F-Jacket, Beam Pistol, Communicator.							



NOLAN VANLAN

Petty Officer 1st Class Nolan Vanlan is the C.S.F. Lockley's acting Chief Engineer and a ten-year enlisted veteran of the Space Fleet Service.

Vanlan is a competent technical engineer who was promoted to his current position when the ship's previous Chief Engineer was lost in the tragic shuttle incident. Unlike Captain Watts, Vanlan is described as a hyperactive, coffee addicted, social extrovert. While his extremely enthusiastic energy takes a little acclimation, Vanlan is well liked and respected by his crew mates

The active service robot can be summoned for assistance either by communicator or through one of the ship's computer terminals. While these robots are not truly a sentient artificial intelligence their lengthy service on the Lockley has contributed to their development of a somewhat quirky and individual personality. The Engineering team assures that this behavior is simply a data processing glitch and human mimicry from decades of service on the Lockley. Over the years, ED-2 has developed a male persona that is somewhat impatient and conveys an attitude that can best be described as "judgmental" in its assessment of situations.

P.O. 1 ST CLASS NOLAN VANLAN							
Race: Human		Gender: M		Age: 32			
Class: TEC.		Sub: ENG.		Level/Save: 4 (Enl.)			
HP	STR	CON	DEX	INT	CHA	PSI	AR
22	13	12	09	14	08	09	-1
EQ: Tech kit, Communicator.							

SERVICE ROBOT ED-2

The C.S.F. Lockley is equipped with two service robots called ED-1 and ED-2 that attend to various maintenance and support needs for the ship and its crew. The name ED is an acronym for Engineering Droid, but the crew likes to refer to them with the more familiar nick names of "Ed" and "Eddy" respectively. The robots are designed to perform work in hostile environments too extreme for humanoid crew members and aid with routine tasks. One in particular being the containment of the Lockley's seemingly never-ending Space Lice infestation. Typically, these service robots work in 12-hour cycles with one robot docked in its service alcove for charging or repair while the other is active.



SERVICE ROBOT: ED-2 “EDDY”	
Encountered:	1
Movement:	150', (50')
Intelligence:	Average
Psi Potential:	N/A
Hits:	24 Hit Points
Armor:	-3
Combat Skill:	12
Save As:	Level 3
Attacks:	1
Damage:	1d8/Elec-Stun
Morale:	N/A
XP:	50



RIGELLIAN SPACE LICE

Rigellian Space Lice are a larger and more aggressive variety of the extraterrestrial lice species. They will perceive any lifeform they encounter within 10 feet as a potential food source and attempt to feed on it. Like other predatory parasitic organisms, Space Lice will hunt and pursue potential hosts who are not trying to eat them first. Their bite is painful but does not cause any noticeable damage. Space Lice bites cause severe swelling, itching, and

irritation. Like typical space lice, the Rigellian variety are known to carry an infectious disease that causes illness in its victims (S&S-2E, Pg. #61).

RIGELLIAN SPACE LICE	
Encountered:	2d4, (2d4)
Movement:	90', (30')
Intelligence:	None
Psi Potential:	None
Hits:	1 Hit Point
Armor:	-2
Combat Skill:	11
Save As:	Level 1
Attacks:	1 Bite
Damage:	Disease (Pg. #61)
Morale:	7
XP:	5

ADJUSTING DIFFICULTY

If the Players are using intermediate level characters in this adventure the Space Master is encouraged to adjust the number of adversaries proportionate to the number and experience of the Player Characters participating. Space Masters are also encouraged to add random encounters and space hazards to this mission, as described in the 2nd Edition Rules, during travel or periods of inactivity whenever appropriate.

CONCLUSION

Success in this mission is achieved if the PC's are able to eradicate all Rigellian Space Lice on Deck-2 and avoid becoming infected. The nasty little beasties are worth 5 XP each and the gratitude of the Captain. PC's who demonstrate good role playing, teamwork and problem solving should be awarded an additional 10 XP each. Any character who becomes infected by the Space Lice will be docked all XP earned during the mission and have the pleasure of a very itchy stay in sick bay for 1d4 days.

MISSION #2

"DELTA-ORCONIS"

This mission features a first contact scenario with a potentially aggressive alien race. The PC's will have to decide between having the courage to repel the borders or the wisdom to dissuade an interstellar conflict.

ORDERS

Upon completing the delivery of supplies to the Confederation space station at Deneb (*Planet #20*) the Lockley receives new orders from Space Fleet Command to survey a Class-N planetoid, designated "Delta-Orconis", that is transitioning through Confederation Space between Epsilon Eridani (*Star #05*) and Tau Ceti (*Star #06*).

SPACE MASTER: *As a rogue planet, Delta-Orconis is not charted on either the Galactic Map or recorded in the Tauran Archives. Since it does not belong to a solar system the planetoid now drifts freely in space propelled by the momentum of its expulsion and cosmic currents.*

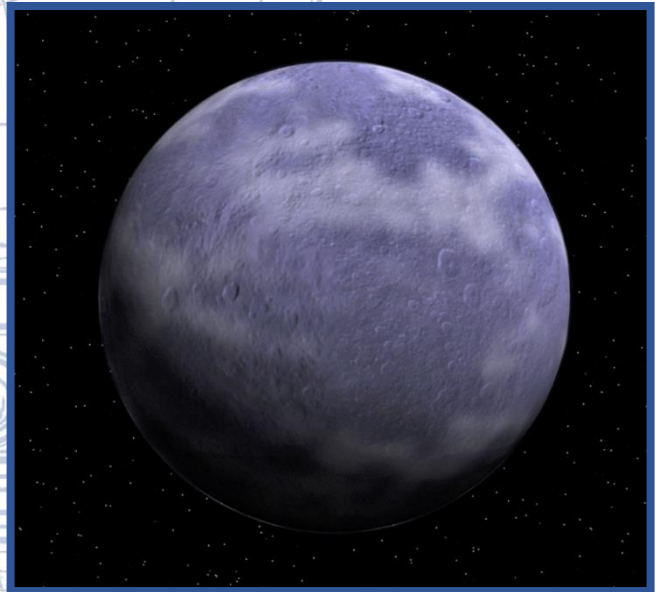

MISSION DETAILS

Delta-Orconis is a rogue planetoid that was expelled from its solar orbit after a cataclysmic celestial event. While the planetoid has been tracked for years by Confederation scientists this is the first time its trajectory curve has been stable enough to allow approach. Additionally, Confederation Scientists have detected that some internal force seems to be influencing the speed and direction of the planetoid.

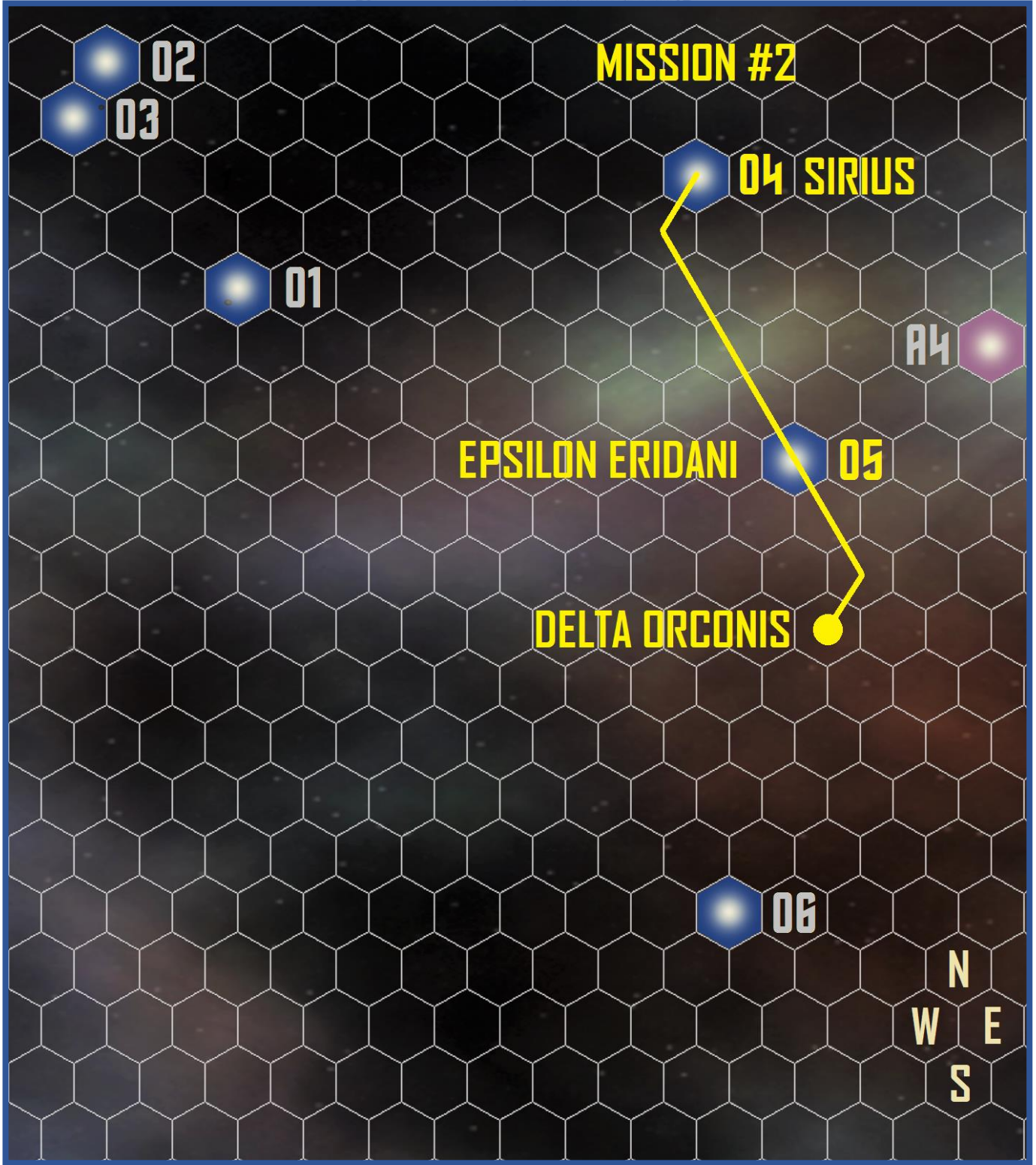

If Delta-Orconis continues on its current trajectory and speed, it will cross the navigational barrier of the Forbidden Star System A3 (*Star #A3*) and become inaccessible to travel within the year.

The current location of Delta-Orconis is four light-years directly South of Epsilon Eridani (*Star #05*) on the Galactic Map. With his new orders in hand, Captain Watts directs the Helm to set a course from Deneb to the rogue planetoid at hyperwarp factor 4. At this speed it will take the Lockley two and a half days to reach its destination. After the customary awkward pause of the ship's faulty helm connection, the Captain's command reaches the engine room and the hyperdrive shudders to life.

SPACE MASTER: While enroute to Delta-Orconis it is recommended that the SM check for random galactic encounters and space hazards as described in the 2nd Edition Rulebook (S&S-2E: Pg. #31 - #35).

As the Lockley reaches hyperwarp factor 4 the new crew members experience even stronger vibrations than before. The noticeably more significant shake throughout the ship's elderly hull will cause a -2 penalty to all physical actions requiring an attribute or skill check while enroute. Upon arrival at Delta-Orconis the Lockley will establish a geo-synchronous orbit and

begin sensor scans and survey mapping of this strange new world.

Upon arrival at Delta-Orconis the Lockley begins scanning and mapping the wandering purple colored planetoid. After two hours of sensor sweeps of the surface one of the Lockley's science officers, Ensign Inoue, detects two small slow-moving objects approaching the Lockley from the planetoid below. As a precaution, Captain Watts orders the ship to readiness and raises half-shields. Within a few moments there is series of soft muffled thuds against the hull as something collides with the ship. Seconds later, the Lockley's alarm indicators flicker from yellow to blaring red as an intruder alert sounds throughout the ship. The ship's internal security sensors have detected a group of unidentified lifeforms has forced open the cargo bay airlock on Deck-6 and invaded the ship. Captain Watts dispatches the PC's to assist with containing the intruders and instructs them to rendezvous with Security Chief T'Shana, on Deck-7.

In accordance with Space Fleet procedure the compromised deck has been evacuated and sealed. The PC's will find Lt. T'Shana waiting for them on Deck-7 at a personnel hatch leading to Deck-6. T'Shana will provide each of the PC's with either a beam pistols or electro-stun gun (Depending on their specialty) and a communicator. She

leads the party through the hatch on to Deck-6 which has become covered in a lite vapor of smoke floating in the air, most likely caused by a small electrical fire. Within moments the party locates a slow-moving group of dark lumbering metallic figures wandering about the corridors. The invaders appearance is somewhat reminiscent of an oddly shaped cannon ball with arms and legs attached to it. The strange aliens appear to be removing parts of the ship from the hull and dragging them back towards the airlock. There does not seem to be any specific pattern or reason to what materials the aliens are removing or semblance of an intentional plan. It simply looks like they are stripping the Lockley for parts right before the PC's very eyes.

SPACE MASTER: *The intruders consist of a group of 3d10 Orconian Raiders that entered the Lockley from an exterior airlock hatch. The two objects that were detected by the Lockley's sensors are Orconian scout ships that were sent from the planetoid to investigate the orbiting starship. The scout ships, which are equivalent to shuttles, are heavily armored transports equipped with defensive screens but no weapons.*

DECK-6

This Deck on the Lockley contains various laboratories, enlisted crew quarters, support facilities, and cargo storage. The party will find the Orconian Raiders removing machinery and components throughout the rooms in the central hub and dragging them back to the airlock in Cargo Bay #1 where they entered the ship. The airlock doors are intact, but the locking mechanisms have been bypassed and are now under the control of the Orconians who are using them to remove the parts they have scrounged from the Lockley.

#1 RECREATION ROOM

This room contains an all-purpose recreation area, relaxation lounge, and fitness center for the ship's crew. It is a high traffic area with crew members from all parts of the ship visiting for exercise and relaxation.

#2 ARMORY

This restricted access room is a secure storage facility for small arms, armor, and munitions.

#3 MOLECULAR FABRICATOR

This room contains the Lockley's molecular fabrication device and an operator's control console.

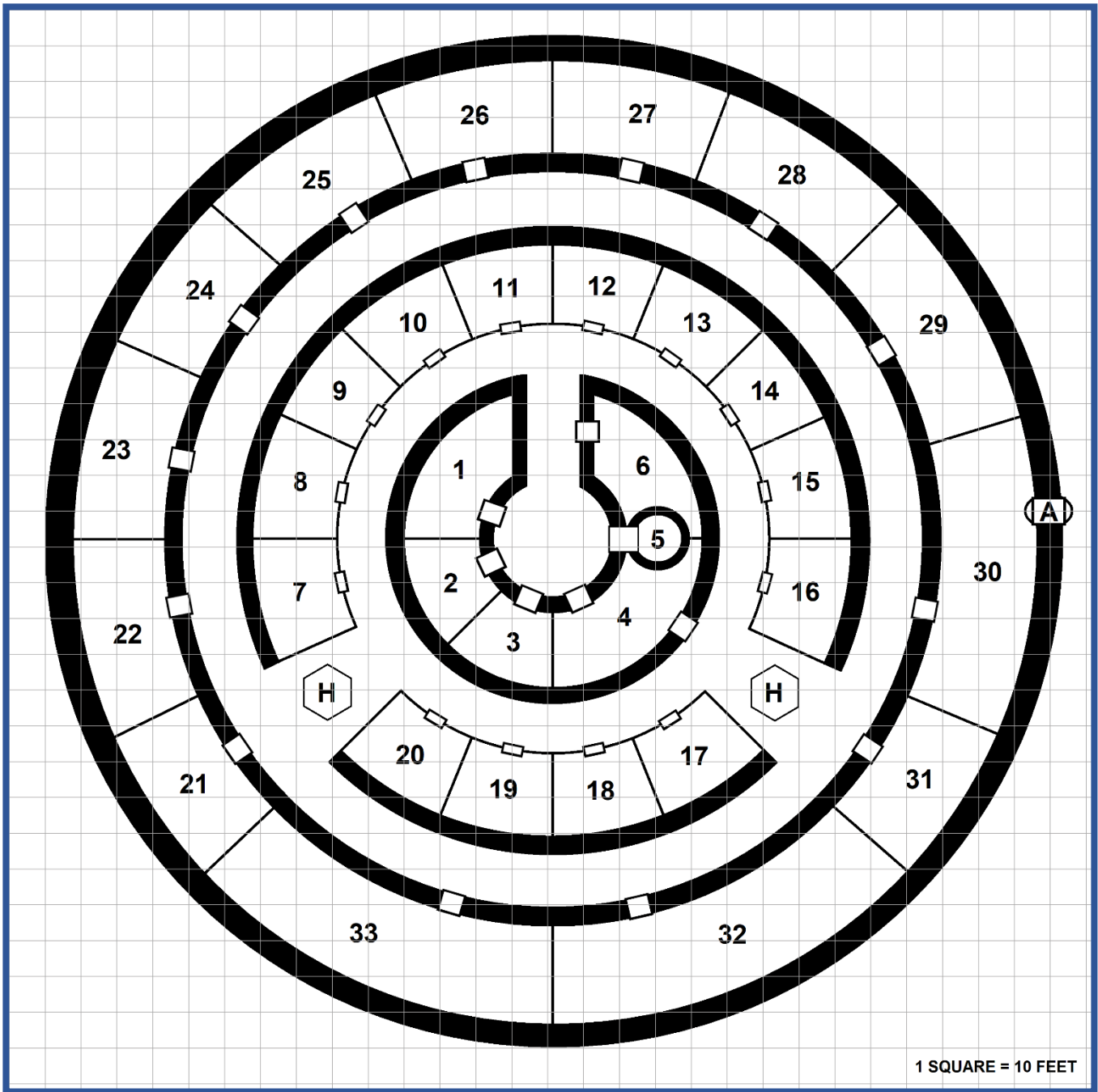

#4 SPACEMEN'S CLUB

This room contains the enlisted personnel's lounge and off-duty entertainment facility. Like the recreation room, this compartment is a high traffic area frequented by the enlisted personnel and passengers.

#5 TRANSIT LIFT

This area contains a lift car station that provides rapid transit between decks.

#6 ENLISTED MESS

This room contains the enlisted personnel's kitchen, food processor units, and dining area.

#7 - #16 ENLISTED QUARTERS

These rooms are all designated as double occupancy enlisted personnel living quarters. Each unit contains a shared lavatory, two beds, and two personal item storage lockers.

(H) PERSONNEL HATCH

This is a restricted access service hatch and ladder-well that provides access between decks.

#17 - #20 NCO/VIP QUARTERS

These suites are designated as single occupancy non-commissioned officer living quarters and VIP passenger rooms. Each unit contains a private lavatory, single bed, personal item storage closet, and a work desk with private computer terminal.

(H) PERSONNEL HATCH

This is a restricted access service hatch and ladder-well that provides access between decks.

#21 - #29 SCIENCE LABS

These rooms contain various scientific research and development laboratories.

#30 CARGO BAY 1

This room is a cargo bay used to house various supplies, freight or cargo carried by the Lockley. The exterior airlock hatch (A) for Deck-6 is located in this cargo bay.

#31 SHIP'S LOCKER

This restricted access room is used for the secure storage of the crew's personal property and equipment.

#32 CARGO BAY 2

This room is a cold storage cargo bay used to house various refrigerated supplies, freight or cargo carried by the Lockley.

#33 CARGO BAY 3

This room is a liquid storage cargo bay used to house various liquid freight or cargo carried by the Lockley.

MISSION NPC'S

Captain Watts, acting Chief Engineer Vanlan, and service robot ED-2, who were first introduced in Mission #1, will be available for use in this adventure as well as two new crew members, Security Chief T'Shana and Security Officer Riley. In order to successfully complete this mission all NPC's must survive this adventure.

T'SHANA

Lieutenant T'Shana is the C.S.F. Lockley's incumbent Chief of Security and has served on the ship for twelve years. T'Shana began

her Space Fleet career on the Lockley as an Ensign after graduating with honors from the Space Fleet Academy. Typical of most Taurans, Lieutenant T'Shana appears devoid of emotion and socially aloof. Little is known about her other than a few rumors that she is an orphan and experiences particularly severe episodes of blood fever. T'Shana is well respected among her peers as a meticulous professional and received two commendations under the Lockley's former commander, Captain Valeria Hernandez.

LIEUTENANT T'SHANA

Race: Tauran		Gender: F		Age: 67			
Class: Mil.		Sub: Sec.		Level/Save: 3 (Ofc.)			
HP	STR	CON	DEX	INT	CHA	PSI	AR
21	13	11	09	15	10	09	-2
EQ: Field Jacket, Beam Pistol, Communicator.							



RANDALL RILEY

Spaceman Apprentice Randall Riley is one of the more recent additions to the Lockley having joined the crew two years ago. Accounts vary on how he earned his nickname of "Red Shirt Riley" but rumors persist that it is due to his tendency to be impetuous and impatient. SM Apprentice

Riley is well liked by his crew members and rumored to be able to drink most of them under the table when on shore leave. Riley is very inquisitive and sometimes sticks his nose into situations that could get it shot off. He is unpredictably candid about what is on his mind at the worst possible time and suffers from a lack of diplomatic tact.

utilize a protective 4-foot-tall bipedal robotic encounter suit whenever they are outside their natural swamp-like environment. These armored encounter suits are shielded against beam, projectile, and melee attacks reducing any successful hit's damage by 50%. While the robotic suits are exceptionally durable, their movement is slow and lumbering.

SM APPRENTICE RANDALL RILEY							
Race: Human		Gender: M		Age: 24			
Class: Mil.		Sub: Sec.		Level/Save: 2 (Enl.)			
HP	STR	CON	DEX	INT	CHA	PSI	AR
12	10	12	10	08	07	03	-1
EQ: Beam Pistol, Communicator.							



THE ORCONIANS

The Orconians are an aggressive race of gelatinous amoeboid organisms with a serious conquest-oriented superiority complex and the only surviving inhabitants of the rogue planetoid Delta-Orconis. After the expulsion of their planet from its solar system the Orconians have moved underground closer to the planet's core for heat and protection. The Orconians are more technologically advanced than the Confederation in some areas but deficient in others. For example, they do not have hyperdrive or teleporters, but they do have advanced robotics and cybernetics. Orconians are scavengers by nature and advance their own technological progress by stealing or reverse engineering technology from others. The Orconians

ORCONIAN RAIDERS	
Encountered:	1d10, (2d10)
Movement:	90', (30')
Intelligence:	Average
Psi Potential:	2d6+6, Active
Hits:	2d8
Armor:	-4
Combat Skill:	12
Save As:	Level 2
Attacks:	1 (Weapon)
Damage:	Beam 2D6
Morale:	9
XP:	15

SPACE MASTER: *The PC's should be encouraged to utilize any and all resources available to them on the Lockley. The PC's will find communication with the Orconian's troublesome and that their singled minded pursuit for new technology will be difficult to dissuade. The Orconian's will meet the PC's with aggression and hostility seeing them as merely an obstacle to achieving their objectives. The Orconian's are a psionically active species who have a strong telepathic connection with each other. Each of the Orconian encounter suits is equipped with an integrated disruptor weapon which has the same characteristics in-game as a beam pistol.*



CONCLUSION

Success in this mission can be achieved in one of two ways. The first way is through force, by repelling or eradicating the alien invaders from the ship. The second way is through finding a way to dissuade the invaders from remaining on the ship by diplomacy or guile. In addition to enemies defeated, the PC's should be awarded an additional 30 XP for successfully stopping or dissuading the aliens. Space Masters should also award the PC's with a bonus of 10 XP for good role-playing, teamwork, and creative problem solving. Mission failure will result if any of the required NPC's are killed or if the PC's are unable to stop the Orconian's advance through the ship. If this occurs, the PC's should be docked all XP earned for the adventure. If the Orconian's prevail they will seize the Lockley forcing the surviving crew to abandon ship in the escape pods and remaining shuttle.

ADJUSTING DIFFICULTY

If the Players are using intermediate level characters in this adventure the Space Master is encouraged to adjust the number of adversaries proportionate to the number and experience of the Player Characters participating. Space Masters are encouraged to add random encounters and space hazards to this adventure, as described in the 2nd Edition Rules, during travel or periods of inactivity whenever appropriate.

MISSION #3

“THE DERELICT”

The mysterious arrival of a derelict Zangid warship in Confederation Space causes quite a stir for the crew of the Lockley. PC's are urged to pay attention to the details on this mission because not everything is as it seems.

ORDERS

Admiral Amano at Space Fleet Command reports that a merchant freighter has detected a derelict Zangid warship drifting in deep space 3.5 light-years South of the Tau Ceti system (*Star #06*). The Lockley is here by ordered to investigate the report, locate the derelict, and ascertain if any survivors are present.

MISSION DETAILS

After the encounter with the Orconians the Lockley has docked at the merchant station orbiting Tau-Ceti III (*Planet #27*) for repairs and E.U. recharge. The six light year journey from Delta-Orconis to Tau Ceti was uneventful and provided a welcome respite for the crew. While at the space station, Captain Watts receives new orders from Admiral Amano to investigate the report of a derelict Zangid warship that was found drifting through Confederation Space.

The Lockley's crew is recalled from leave at the Tau Ceti station and the ship makes way at Hyperwarp Factor 2. At this rate, the Lockley will arrive on scene in two days with no noticeable vibration irritating the crew's already frayed nerves. Since the Zangid are well known as pathological instigators, Captain Watts chooses to proceed cautiously with the Lockley's defensive screens at half-power and the ship at an elevated state of readiness.

SPACE MASTER: *While enroute to the Derelict it is recommended that the SM check for random galactic encounters and space hazards as described in the 2nd Edition Rulebook (S&S-2E: Pg. #31 - #35).*

The freighter Captain's account of the derelict's location was perfectly accurate, but space is a vast empty place and the derelict is drifting. When the Lockley arrives in the area it will need to begin a sensor sweep to locate the ship. Captain Watts asks the PC's to assist with finding the Derelict by performing inquiries to the ship's computer to decipher the collected sensor data.

SPACE MASTER: *The PC's will need to complete three successful technical skill checks or INT attribute checks to locate the position of the derelict and its surrounding debris field.*



When the PC's locate the Derelict, it will be found adrift in a large field of debris and wreckage. The deceased bodies of eighteen Zangid warriors can be detected floating among the various mechanical parts and metal flotsam. The Zangid warship, or at least what is left of it, is an old E-2 Class Raider with three of its four decks opened to space by a massive fissure

in the ship's hull. Further scans of the ship reveal that the command deck appears to be intact and pressurized with subtle indications of electrical power present. These faint power surges must have been detected by the merchant freighter's navigation sensors forcing the ship to alter course to avoid the obstacle.

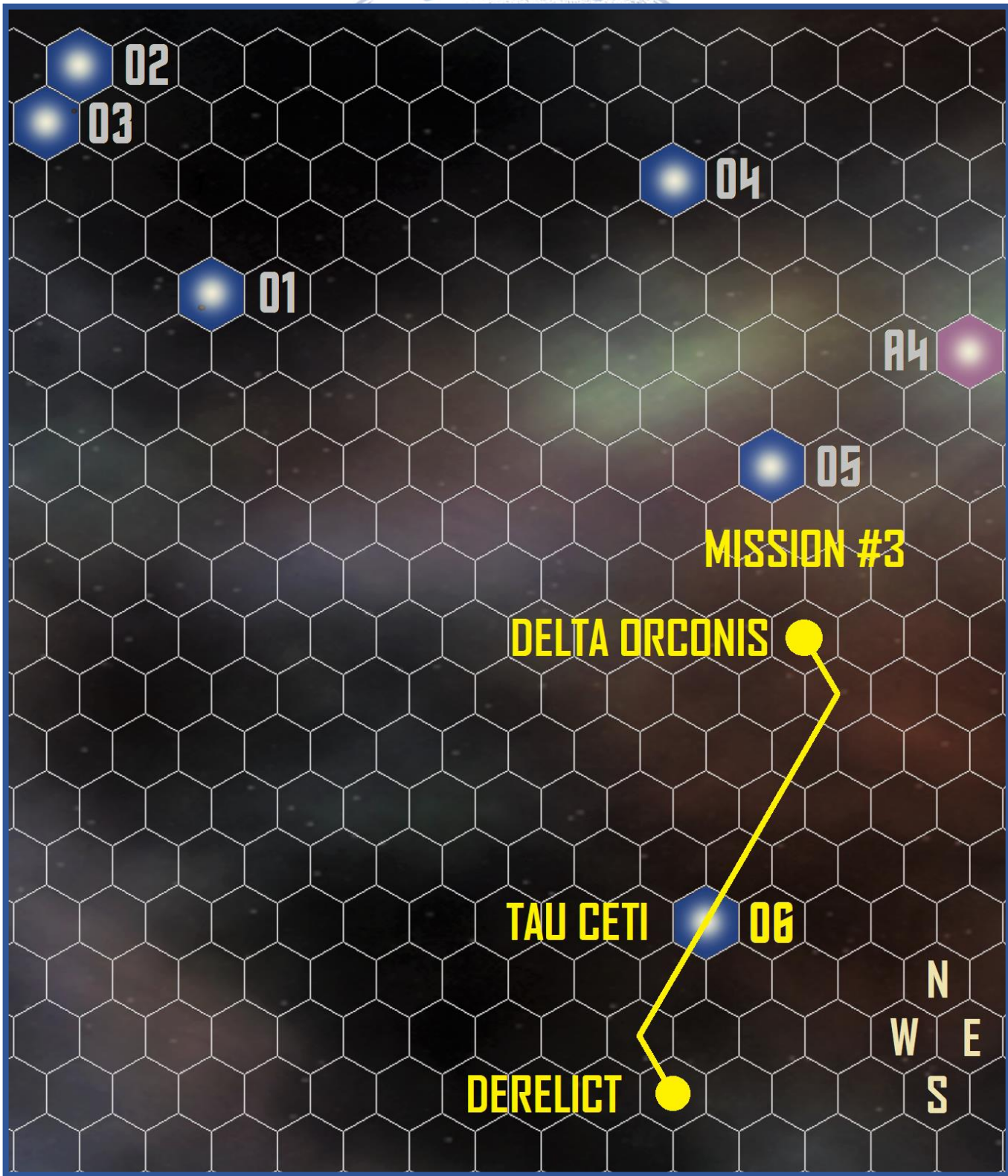

Curiosity quickly gets the better of Captain Watts' usually abundant sense of caution. He assembles a boarding party composed of T'Shana, Vanlan, Service Robot ED-2, and the PC's to teleport over to the ship. The Captain instructs the boarding party to have a look around the wreckage to see if anything there can tell us what happened to the ship. Since the cause of the warship's demise is still unknown, Captain Watts insists the crew wear radiation suits while onboard the Derelict.

EQUIPMENT

The PC's will each be provided one radiation suit with oxygen tank, one beam pistol or electro-stun gun, and a communicator from the ship's stores. NPC's T'Shana and Vanlan will also be carrying a beam pistol, auto-analyzer, and universal translator.

MISSION NPC'S

Captain Watts, Lieutenant T'Shana, acting Chief Engineer Vanlan, and the ship's service robot ED-2, who were introduced in the previous missions, will be available for use in this adventure. A new Zangid NPC, and potential adversary, named Captain Kor Mo' Kosht will be introduced during this mission but will have no interaction with the PC's at this time. To successfully complete this mission all required NPC's must survive this adventure.

DERELICT ZANGID E-2		
Ship's Name:	Z.S.F. Haru-Mot	
Ship Type:	E-2 Raider, Mk-1	
Affiliation:	Zangid Imperium	
Crew Compliment:	5/25	
Command Rank:	Corporal (Ensign)	
Hull Size:	1 ½	
Construction Cost:	35 CP	
Power Pile Base:	35 (1x Half Pod)	
Habitable Decks:	4	
Teleporter Cap:	2 At A Time	
Beam Banks:	1	
Meteor Gun:	2 (1d6x2)	
Shuttle Ships:	N/A	
Sick Bay Cap:	2 At A Time	
Cryo-Tubes:	2	
Ship's Locker:	5	3

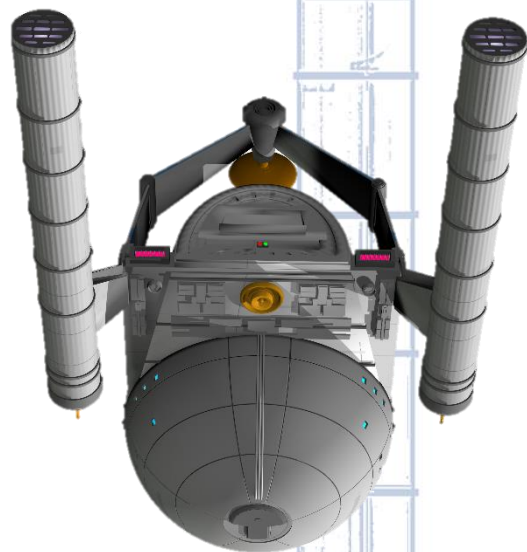

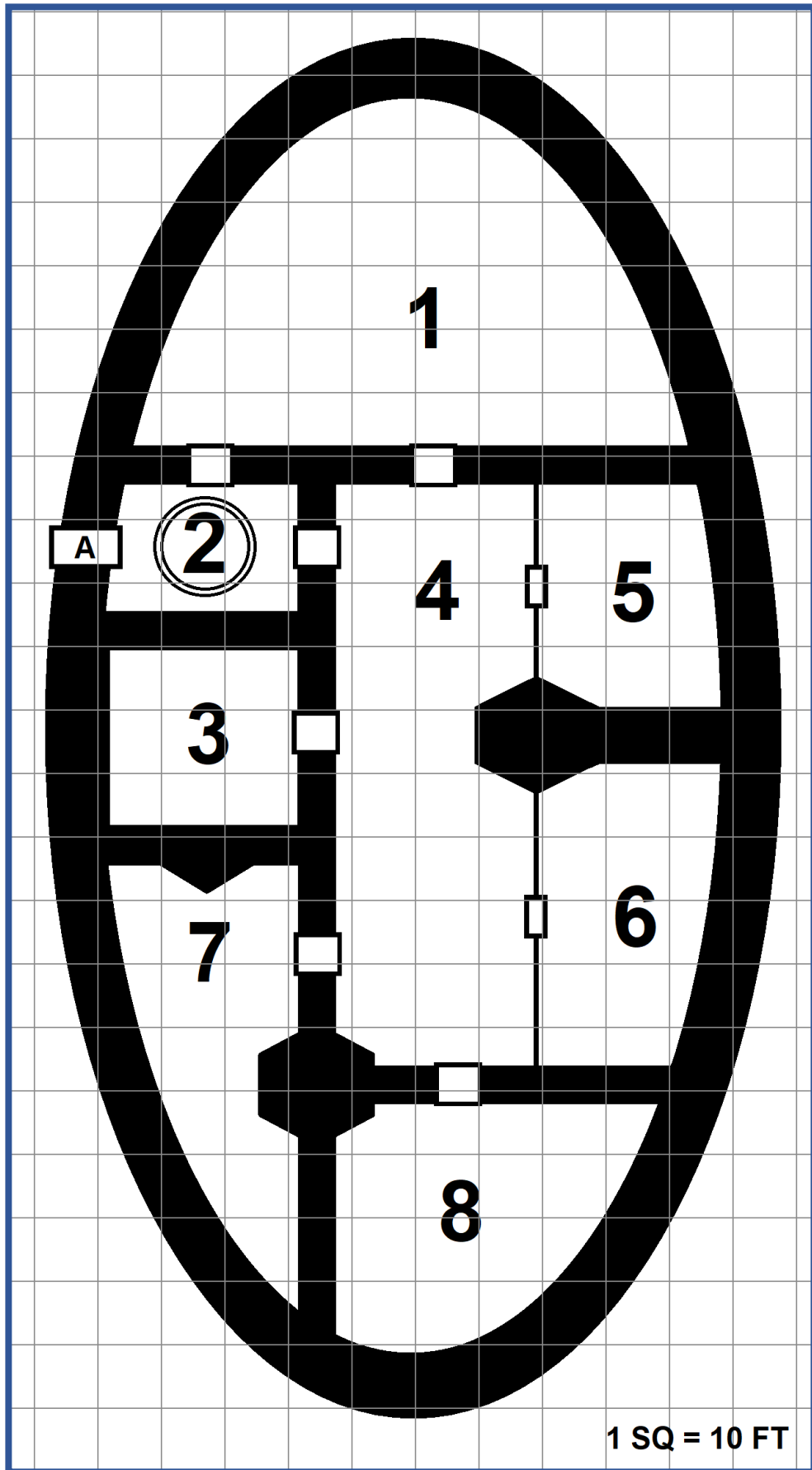

HARU-MOT COMMAND DECK

The Z.S.F. Haru-Mot's command deck is the only area of the ship that is still intact and not open to the vacuum of space. This deck contains the ship's bridge, robot service bay, Captain's quarters, computer room, and teleporter bay.

#1 BRIDGE

This room is the Z.S.F. Haru-Mot's command bridge and contains five control operator console stations.

#2 ACCESS TUBE

This room contains a ladder-well that provides maintenance access throughout the entire ship. The access tube hatch is sealed shut on this level and inaccessible due to a hull breach below.

#3 ELEVATOR

This room contains the ship's elevator lift. Like the access tube the lift is inoperable due to the hull breach on the decks below.

#4 CENTRAL CORRIDOR

This is the main corridor that provides access to all compartments on the deck.

#5 COMPUTER ROOM

This room contains a private computer library and interface room. The computers contained in this room are without power and inoperable.

#6 ROBOTICS BAY

This room is a custom installed robot service bay with six alcove units that are locked with a biometric access device.

#7 CAPTAIN'S QUARTERS

This room is a single occupancy officer's living quarters with a storage closet, private lavatory, and a custom installed stasis pod.

#8 TELEPORTER BAY

This room contains the ship's teleporter unit and operator's control console.

THE SURVIVOR

Upon arrival on the derelict's command deck the boarding party will find that the interior atmosphere is severely degraded and barely breathable. The entire deck is dark with main power off throughout the vessel. Only a few support systems are still running on severely depleted battery power. Vanlan locates the derelict ship's bridge and begins an assessment of the ship's systems and condition.

While Vanlan performs an inspection of the derelict's systems, T'Shana leads the rest of the boarding party on a room to room search. The party soon locates the Captain's Quarters (#7) and finds a stasis pod inside with a Zangid male in a state of suspended animation. The Zangid in the stasis pod appears to be in excellent health

considering the state of the ship around him. The ship's emergency escape pods are all present and untouched. Unfortunately, the frozen corpses floating outside in the debris field account for the rest of the ship's crew.

and deadly trap set for anyone who dared tamper with the Captain's stasis pod without knowing the correct bypass protocols.

CAPTAIN KOR MO'KOSHT							
Race: Zangid		Gender: M		Age: 53			
Class: Mil.		Sub: Sec.		Level/Save: 6 (Ofc.)			
HP	STR	CON	DEX	INT	CHA	PSI	AR
41	12	15	09	10	09	04	-1
EQ: Beam Pistol, Zangid Fighting Dagger.							

SECURITY ROBOTS	
Encountered:	6
Movement:	150', (50')
Intelligence:	Animal - Low
Psi Potential:	N/A
Hits:	2d8
Armor:	-1
Combat Skill:	10
Save As:	Level 2
Attacks:	1
Damage:	Weapon (2d6)
Morale:	N/A
XP:	15

While T'Shana is examining the Zangid stasis pod her proximity to the device triggers some kind of preprogramed response. A series of flickering lights suddenly illuminates the stasis pod control panel. The subtle whirl of intricate mechanical functions and the sound of gurgling fluids begin to fill the silence. The dim lights of an inadequately powered monitor begin to glow showing the occupants slowly rousing bio-signs. By contrast, at the end of the central corridor the hiss of pneumatic pumps propelling six loudly clanging metal door panels penetrates the previous silence of the command deck. Moments later the unmistakable sound of mechanical legs stepping onto metal floor plates echoes down the corridor as six Zangid security robots emerge from their alcoves (#6) and begin searching for intruders. An elaborate

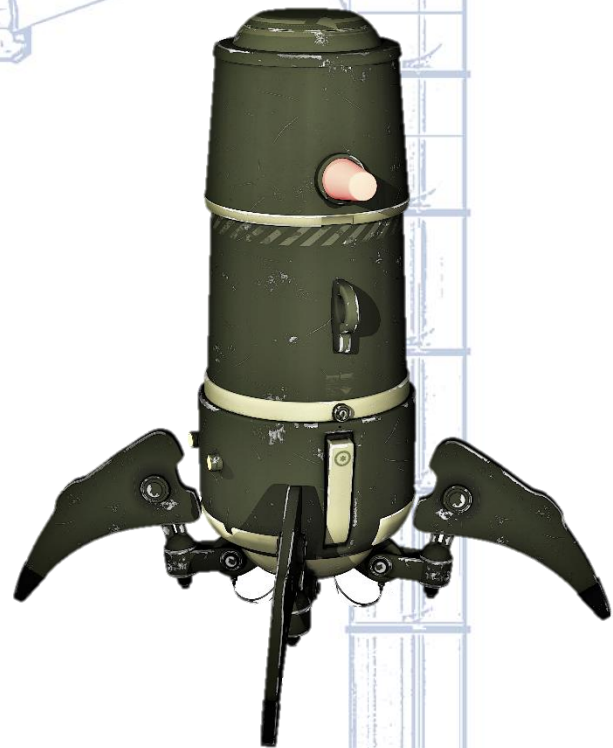

SPACE MASTER: *The six security robots are a custom upgrade to the Haru-Mot's security and mutiny pacification systems. The robots are programmed to search every room of the ship for potential threats and boarding parties. While they are particularly useful when your pack of Zangid Dogs goes rabid, they are not an effective welcoming committee. The robots will automatically attack any lifeform that is not Zangid or has not been excluded as a threat. Each of the robots is equipped with an integrated beam pistol that is set to "kill"/disintegrate. The robots are not designed to be terribly precise, but they will never get tired and never give up.*

While T'Shana and the PC's are occupied fighting off the robots, Vanlan conducts his analysis of the derelict from its bridge. Vanlan's inspection of the ship's instruments indicates that the old E-2 had experienced a hyperdrive containment breach which caused the rupture in the lower hull. The universal translator picks up some suspicious comments in the ship's log that suggest that a mutiny may have been underway at the time of the breach. Vanlan contacts T'Shana with his communicator and recommends that the stasis pod should be teleported back to the Lockley where the occupant can be revived and receive medical care. T'Shana, still up to her pointy Tauran ears in Zangid robots,

agrees with Vanlan's assessment and calls the Lockley's teleporter room to arrange transport for the boarding party and the stasis pod.

When the boarding party teleports back to the Lockley the stasis pod is quickly whisked away by the ship's medical team. While the entire event has left more questions than answers the members of the boarding party all agree it is good to be back on the Lockley. Moments before returning to Hyperwarp, Captain Watts orders fire control to torpedo the derelict to ensure it does not attract unwanted attention or continue to pose a navigational hazard for merchant ships.

ADJUSTING DIFFICULTY

If the Players are using intermediate level characters in this adventure the Space Master is encouraged to adjust the number of adversaries proportionate to the number and experience of the Player Characters participating. Space Masters are also encouraged to add random encounters and space hazards to the adventure, as described in the 2nd Edition Rules, during travel or periods of inactivity whenever appropriate.

CONCLUSION

Successful completion of this mission involves finding the location of the derelict ship, retrieval of the Zangid officer, and

survival of the required NPC characters. In addition to any XP earned for defeated adversaries, the SM should award the PC's 30 XP for successfully locating the Haru-Mot and 30 XP for retrieving the stasis pod. The PC's should be awarded an additional 10 XP each for good roleplaying, teamwork, and problem solving. The PC's should be docked all XP earned for the mission if any of the required NPC's are killed or the stasis pod is not recovered.

MISSION #4

"THE DISTRESS CALL"

When an unexpected celestial encounter cripples a Confederation starship the Lockley is directed to embark upon a dangerous interstellar rescue that pushes the limits of both the ship and its crew.

ORDERS

The C.S.F. Lockley receives an urgent distress call from the Confederation Destroyer Southfield. The Southfield's Captain reports that they encountered a cosmic dust cloud while enroute to Tau Ceti III (*Planet #27*). The unexpected encounter has damaged their hyperdrive and depleted their energy reserves. With emergency power now failing the Southfield is adrift and defenseless. Currently the Lockley is the only unassigned starship that can reach the

Southfield's position in less than two days' travel time at high hyperwarp.

MISSION DETAILS

Upon receiving the distress call, Captain Watts orders the Lockley's helm to set a course to the Southfield's position, Hyperwarp Factor 6 with Full Screens (Total 90 EU's Per Day). Acting Chief Engineer Vanlan reminds the Captain that the energy expenditure for those parameters exceeds their standard daily energy distribution allowance. Captain Watts appears almost oblivious to his Engineer's warning and mumbles a nearly inaudible curse towards all cosmic clouds while studying his display monitor. Captain Watts knows that every moment that the Southfield is adrift in deep space without her hyperdrive or defensive screens invites disaster. Anxious glances dart between the crew as Vanlan relays the Captain's orders to the engine room and overrides the Lockley's high energy use warnings.

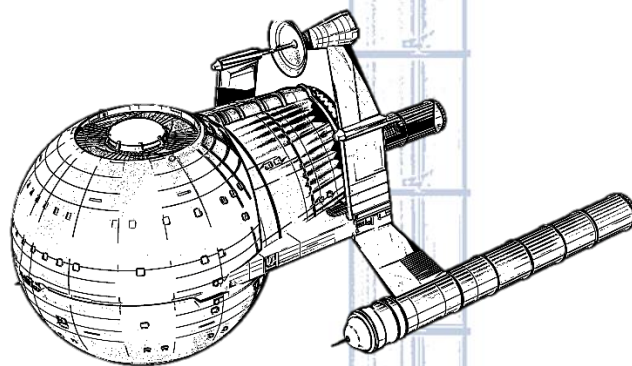

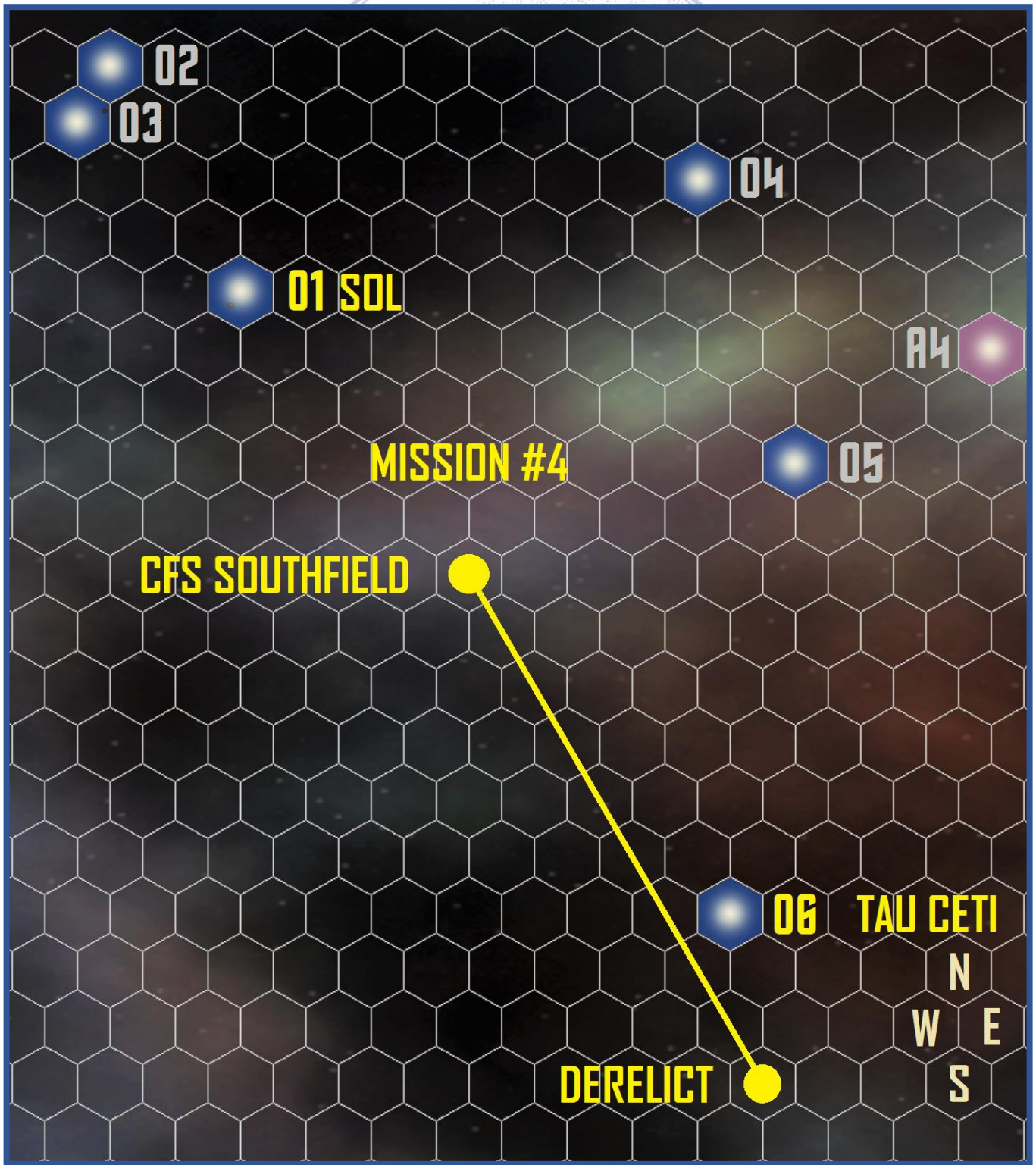

The C.S.F. Southfield is located 6 light-years Southeast of the Sol System (Star #01) and 10 light-years from the Lockley's current position below Tau-Ceti (Star #06). At hyperwarp factor 6 it will only take a day and a half of interstellar travel for the Lockley to reach the Southfield. Prolonged travel at speeds above hyperwarp factor 5 will place a significant strain on the aged starship's hull causing 1d6 points of EU damage for every hour of interstellar travel. The ship's Engineer and any PC with the technical skill can attempt to mitigate this damage while enroute. An unavoidable consequence of the Lockley traveling at this speed is that the vibrations throughout the ship's hull will be so intense that crew members will find that even simple actions will require concentrated effort. All physical tasks attempted while traveling at this speed requiring an attribute or skill check will have a -4 penalty modifier. Any significant changes in a character's physical position (i.e. standing up from sitting in a chair) while on the Lockley during High Hyperwarp will require a Dexterity check roll. If the check is unsuccessful the PC or NPC will fall and receive 1d4 HP of damage. For every hour that the ship is at Hyperwarp Factor 6 the SM should conduct a secret Constitution Check (without penalty) to see if any of the PC's are overcome with Space Sickness. Any

character that has Space Sickness will be temporarily incapacitated by nausea and vomiting for 1d4 turns in which they are unable to perform any other action.

SPACE MASTER: While enroute to the Southfield it is recommended that the SM check for random galactic encounters and space hazards as described in the 2nd Edition Rulebook (S&S-2E: Pg. #31 - #35).



MISSION NPC'S

Captain Watts, Lieutenant T'Shana, acting Chief Engineer Vanlan, and the ship's service robot ED-2, who were introduced in the previous missions, will be available for use in this adventure. A new NPC named Thora Evras, the Captain of the Southfield, will be introduced in this mission and is available to assist the PC's. Successful completion of this mission requires that all NPC's survive this adventure.

THORA EVRAS

Thora Evras is a distinguished Space Fleet Captain and the commanding officer of the recently launched C.S.F. Southfield. As a Daelan, she is fond of mysteries and has a keen eye for political intrigue. Evras has a healthy portion of Daelan paranoia but manages to keep it in check with the discipline of her Space Fleet Training. Considered to be very charismatic for a Daelan, Captain Evras is well liked and respected by her crew.

CAPTAIN THORA EVRAS

Race: Daelan		Gender: F		Age: 50			
Class: MIL		Sub: CMD.		Level/Save: 6 (Ofc.)			
HP	STR	CON	DEX	INT	CHA	PSI	AR
34	10	09	13	10	12	09	-1
EQ: Beam Pistol, Communicator.							

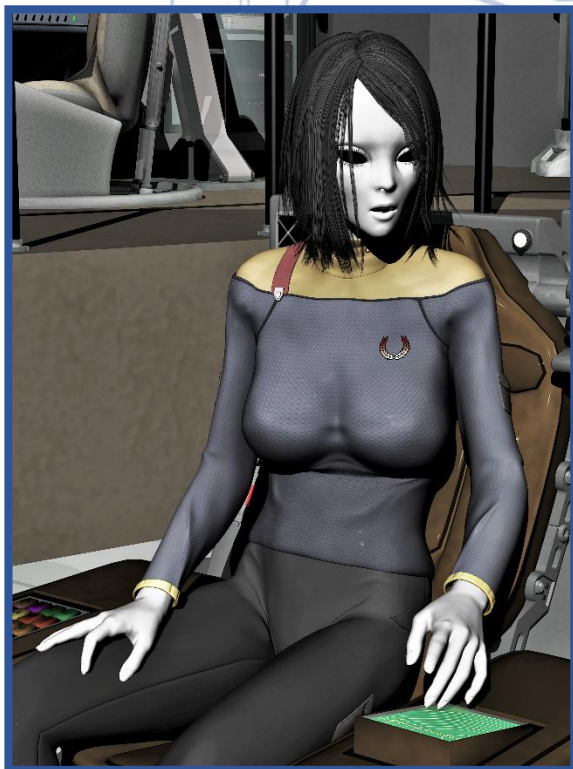

THE UNINVITED GUEST

When the Lockley arrives out of hyperwarp at the Southfield's location an intruder alert is received by the bridge. A robotic probe of unknown origin has been observed floating around the corridors on Deck-6. At present the probe appears to be conducting a survey of the Lockley's interior and does not seem to be hostile or concerned with the crew. While the probe's actions do not pose an immediate threat, the Lockley's crew will have to ensure the intruder is contained or neutralized before docking with the crippled Southfield. Captain Watts places the Lockley on high alert, evacuates Deck-6 and seals off all access to the area. The Captain dispatches Security Chief T'Shana to investigate the incident and directs her to take the PC's with her for back up.

EQUIPMENT

The PC's will be provided a beam pistol or electro-stun gun (Depending on their specialty) and a communicator from the ship's stores for use during this mission.

DECK-6

This deck on the Lockley contains various laboratories, enlisted crew quarters, support facilities, and cargo storage. The party will find the alien probe loitering in the corridor near Cargo Bay #2 (Room #32). The probe will be travelling in a clockwise

direction through the outside corridor ring while conducting its scans of the ship's technology and equipment.

slight electrical shimmer in the air around the probe indicates that it is producing a defensive energy screen which is masking its presence from the Lockley's internal sensors.



ORCONIAN PROBE

When T'Shana and the PC's arrive on Deck-6 they will easily locate the intruder which is a six-foot-tall metallic pod hovering in the air on a suspensor field. It appears to be conducting sensor scans and survey mapping of the Lockley's interior. The alien probe looks like it is constructed out of the same material the Orconian's use in their encounter suits. T'Shana speculates that the probe may have been left behind on the Lockley during the Orconian attack and was activated by the violent shaking of the ship while traveling at high hyperwarp. A

ORCONIAN PROBE	
Encountered:	1
Movement:	90', (30')
Intelligence:	Low
Psi Potential:	N/A
Hits:	4d8
Armor:	-2
Combat Skill:	10
Save As:	Level 4
Attacks:	1
Damage:	Electro-Stun
Special Defense:	Energy Screen
Morale:	N/A
XP:	60

SPACE MASTER: *The Orconian Probe is programed to gather intelligence and locate desirable technology for the Orconian's to use during future raids.*

The probe will continue to conduct its survey scans and ignore the party unless they come within six feet of it. If the party approaches within six feet, the probe will stop what it is doing and attack the closest character with an electro-stun beam.

If the party engages the probe in combat it will deploy four smaller robot drones all armed with integrated beam pistols. The four smaller drones will engage the party in combat while the probe proceeds further down the corridor to continue its scans of the ship. The attack drones appear to be made of scavenged technology harvested by the probe. The drones are single minded machines that will continue their attacks until they are destroyed. The Probe is capable of manufacturing and deploying 1d4 additional drones for its defense once every turn. The Probe will attempt to avoid engaging in direct combat itself whenever possible using the attack drones to provide its security.



BOARDING THE SOUTHFIELD

Once the Orconian Probe and its drones have been neutralized the Lockley can dock with the drifting Southfield. Engineering teams consisting of crew from the Lockley, including Vanlan and the PC's, will be dispatched to assist with repairs.

After several failed attempts to restart the Southfield's engine the PC's will be asked to take a look at the problem with "a fresh set of eyes". The PC's will need to conduct an INT check or technical skill check to see if they can come up with a solution. PC's can make as many attempts as needed to determine the problem with the Southfield's engine.

ATTACK DRONES	
Encountered:	4, (1D4)
Movement:	150', (50')
Intelligence:	None
Psi Potential:	N/A
Hits:	1d8
Armor:	-1
Combat Skill:	10
Save As:	Level 1
Attacks:	1
Damage:	By Weapon, 2d6
Morale:	N/A
XP:	15



SPACE MASTER: If the PC's make a successful INT or technical skill check they will see that the Southfields hyperdrive needs a fresh infusion of energy to "jump start" the ship. A transfusion of 10 EU's from the Lockley's hyperdrive will be sufficient to get the job done.

OLD FRIENDS

With repairs to the Southfield underway, Captain Evras invites Captain Watts, Petty Officer 1st Class Vanlan, and the PC's to join her for dinner in the Southfield's Officer's Club as a thank you for their assistance. As it turns out, Captain Evras and Captain Watts are old friends and rivals from their days at the Space Fleet Academy. Over the course of the evening, and a few strong drinks, Captain Evras reveals that Watts was also considered for the Captain's Chair of this brand-new Cheyenne Class Destroyer but was unfortunately passed over at the last moment in an administrative oversight. An unintentionally bitter portion of salt on a fresh wound for Watts who commands one of the oldest ship's in the fleet. Seeing the uncomfortable shift in Watt's countenance, Evras consoles her old friend with the assurance that when the Lockley is finally decommissioned, he too will have his pick from one of the new ships.

C.S.F. SOUTHFIELD	
Ship's Name:	C.S.F. Southfield
Ship Type:	Destroyer
Ship Class:	Cheyenne
Designation:	DD-225
Commissioned:	2289
Affiliation:	Confederation
Crew Compliment:	20/200
Command Rank:	Commander
Hull Size:	3
Mission Duration:	3 Year Cycle
Construction Cost:	100 CP
Power Pile Base:	100 (2x Half Pods)
Habitable Decks:	12
Teleporter Cap:	4 At A Time
Beam Banks:	2
Ion Torpedoes:	10
Shuttle Ships:	2
Sick Bay Cap:	5 At A Time
Cryo-Tubes:	6
Ship's Locker:	10 4

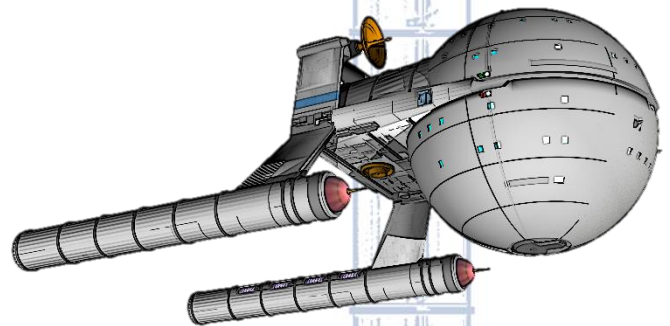

SPACE MASTER: *Unknown to Captain Watts, Evras is secretly aware that Space Fleet Command's decision to pass-over Watts for command of a new ship was not merely an oversight. In light of the Lockley's tragic Shuttle Incident, the Admiralty have lost confidence in Captain Watts' ability to command a new "ship-of-the-line". Captain Watt's difficulty reconciling the loss of his crew members during that fateful incident and his frantic insistence for continued search and rescue missions have not gone unnoticed. Daelan's do love their secrets, and Captain Evras is no exception. She prides herself in being someone who always knows more than anyone else in the room.*

ADJUSTING DIFFICULTY

If the Players are using intermediate level characters in this adventure the Space Master is encouraged to adjust the number of adversaries proportionate to the number and experience of the Player Characters participating. Space Masters are also encouraged to add random encounters and space hazards to this adventure, as described in the 2nd Edition Rules, during travel or periods of inactivity whenever appropriate.

CONCLUSION

Successful completion of this mission requires the PC's to reach the Southfield,

contain or neutralize the Orconian probe, and assist with restarting the Southfield's hyperdrive. In addition to any XP earned for defeated adversaries, the SM should award PC's 30 XP each for containing or neutralizing the Orconian Probe. An additional 30 XP should be awarded to each of the PC's if they figure out how to restart the Southfield's Hyperdrive. The SM should award a bonus of 10 XP for good roleplaying, teamwork, and problem solving. Mission failure will occur if the PC's are unable to contain or neutralize the probe which will prevent the Lockley from docking with the Southfield and rendering assistance. PC's should be docked all XP earned during the mission If any of the required NPC's are killed or if any of the PC's abandoned the party.

MISSION #5

MISSING PERSONS

During a routine mission, the crew of the Lockley receive a mysterious transmission from a stranded Confederation shuttle's emergency beacon. Could this be a distress call from the Lockley's long-lost shuttle and crew?

ORDERS

After getting the Southfield underway for repair at Starbase Alpha, the Lockley's crew turn their attention to completing some

much-needed field repairs on their own ship. Unfortunately, their brief respite is soon cut short when new orders arrive from Commodore Charles Blackthorn at Space Fleet's Exploration Command Center. Commodore Blackthorn's orders direct the Lockley to replace a malfunctioning navigation buoy located 10 light-years from the Lockley's current position.

MISSION DETAILS

Captain Watts surveys the weary command crew as they scurry about the bridge completing repairs. "It looks like we were still in business. I know we are still patching the ship back together after the last mission, but duty calls once again. A vital navigation buoy 10 light-years from our current position has malfunctioned and requires replacement. Helm set a course for nav-buoy marker 117, hyperwarp factor 2." The crew collectively breathe a sigh of relief at the Captain's orders for a slow ride to their next assignment." At this hyperwarp factor the trip to the buoy will take five days and will not produce any noticeable vibrations from the ship's faulty induction coil. After an embarrassingly long pause from the ship's helm control console the order for hyperwarp reaches the engine room just as the helm operator reaches in frustration for a communicator.

Acting Chief Engineer Vanlan has had little to say to anyone since the last mission as he rushes to complete field repairs throughout the ship. In fact, little at all has been seen of the ship's engineer except when he surfaces from the mechanical crawl spaces to seek out a refill of coffee. Patchwork panels and bypass cables litter the corridors as a testament to the daunting scope of the Chief's labors.

The PC's continue to hear persistent rumors among the Lockley's crew about the recovery of a stasis pod containing a Zangid officer being stored in Sick Bay. Some crew members remark that a portion of Sick Bay was recently quarantined, but they assumed it was connected to the Rigellian Space Lice outbreak that recently occurred on Deck 2.

SPACE MASTER: *While travelling to the buoy it is recommended that the SM check for random galactic encounters and space hazards as described in the 2nd Edition Rulebook (S&S-2E: Pg. #31 - #35)*

Upon arrival at the navigational buoy's location Captain Watt's brings the Lockley to a stop 30,000 miles short of the buoy. With a mischievous smile Captain Watts summons the PC's to the bridge. When they arrive, the Captain explains that this would be an excellent opportunity for his new crew members to get in a little

practice with the ship's tractor beam. Watts directs the PC's to use the Lockley's tractor beam to retrieve the malfunctioning space buoy and bring it into the hangar bay. Since the use of the tractor beam at this range will cost 3 EU for each attempt, Captain Watts will allow the PC's three attempts to catch the buoy before handing the task over to one of the ship's fire control officers or engineers.

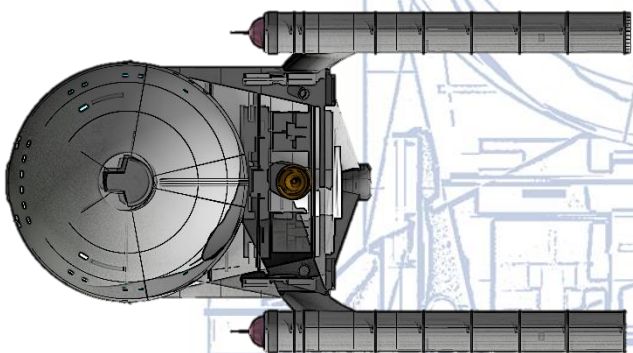

While launching the replacement buoy, the Lockley's communication officer, a tall Andromedan named Ensign Kohvakt, suddenly interrupts with urgent news. "Captain, I've detected an automated distress beacon coming from an asteroid two light-years from our current position. The background radiation in the area is causing substantial interference with the transmission, but it is definitely a Confederation signal." The communication officer's report brings all activity on the bridge to an immediate halt. Kohvakt carefully inspects his console monitors confirming the data displayed, "Captain,

the transmission identification code I am receiving is from our missing shuttle!" The Captain stares for a moment in complete shock at the Officer's report, unable to believe the words he just heard. Sitting down in his command chair, the Captain straightens his uniform in a visible effort to regain his composure.

The chime of the ship-wide address tone breaks the shocked silence as Watts activates his intercom, "This is the Captain; we have received a priority distress signal from a Confederation shuttle located on an asteroid two light-years from our position. Complete the launch of the nav-buoy and prepare for immediate hyperwarp."

Within moments, acting Chief Engineer Vanlan arrives at the bridge, exiting the lift doors. With an anxious glance to the Captain, he takes his seat at the engineering console, "Captain, the engine room stands ready, what are your orders?" Vanlan barely finishes speaking the words, knowing full well what the directive would be, as Captain Watts replies, "Factor 6, Mr. Vanlan". The young engineer wastes no time waiting for the glitchy helm console and relays the Captain's orders directly with his communicator.

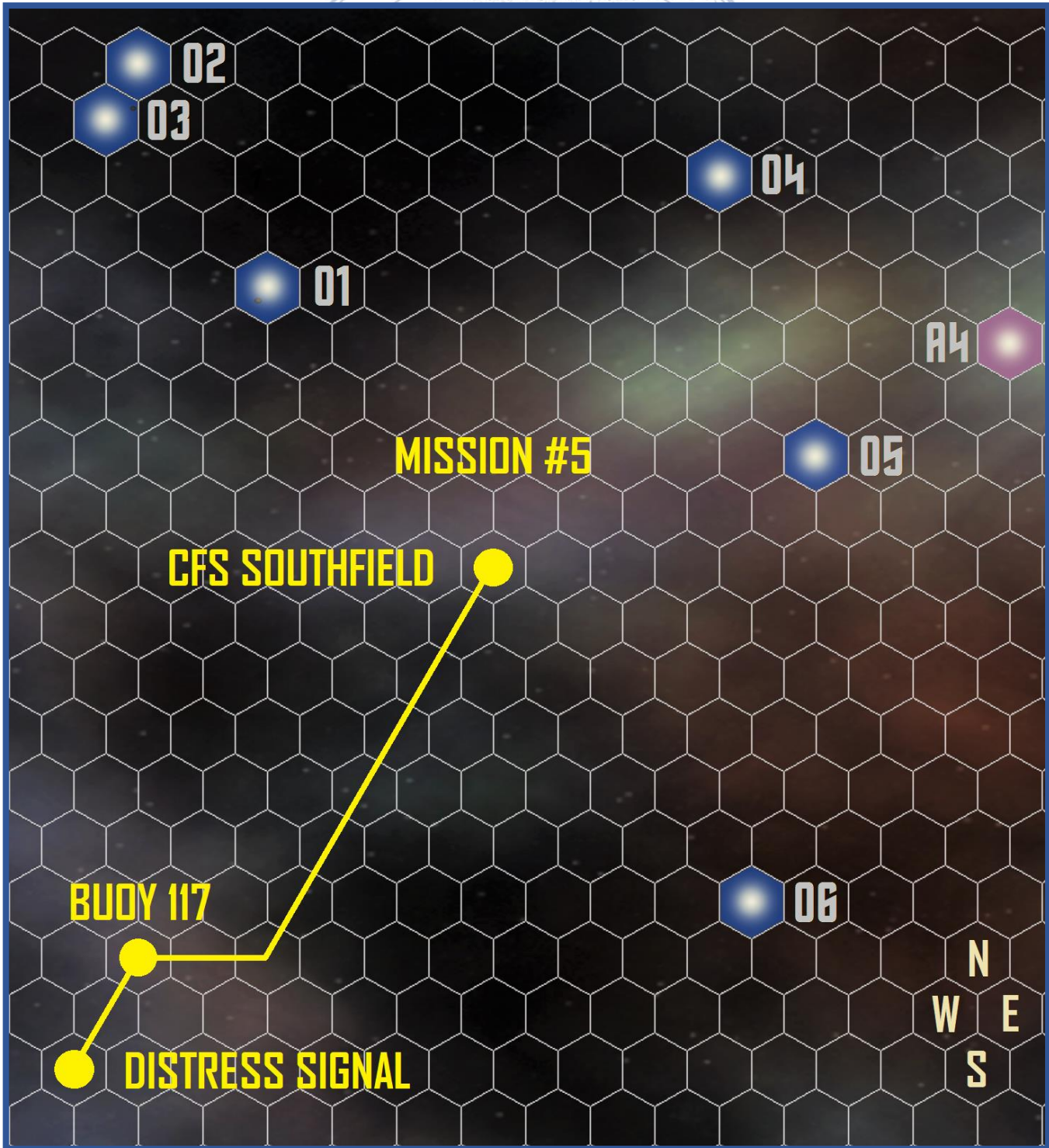

Within moments the Lockley shudders and lurches forward as it accelerates to hyperwarp. At this speed, the Lockley will arrive at the source of the signal in about four hours. The ship's faulty hyperspace harmonics induction coil again produces a nearly unbearable shaking that is felt throughout the hull. All physical tasks attempted while traveling at this speed that require an attribute or skill check will have a -4 penalty modifier. Any significant changes in a character's physical position (i.e. standing up from sitting) during High Hyperwarp will require a Dexterity check roll. If the check is unsuccessful the character will fall, sustaining 1d4 HP of damage. For every hour that the ship is at Hyperwarp Factor 6 the SM should conduct a secret Constitution Check (without penalty) to see if any of the PC's are overcome with Space Sickness. Any character that has Space Sickness will be temporarily incapacitated by nausea and vomiting for 1d4 turns in which they are unable to perform any other action. Vanlan will carefully monitor the Lockley's progress during the trip as the stresses of high hyperwarp on the hull will cause 1d6 points of EU damage to the ship for every hour of interstellar travel.

SPACE MASTER: *Since the Lockley will be at interstellar travel for less than a day the SM should fore-go any random galactic encounters and space hazards.*

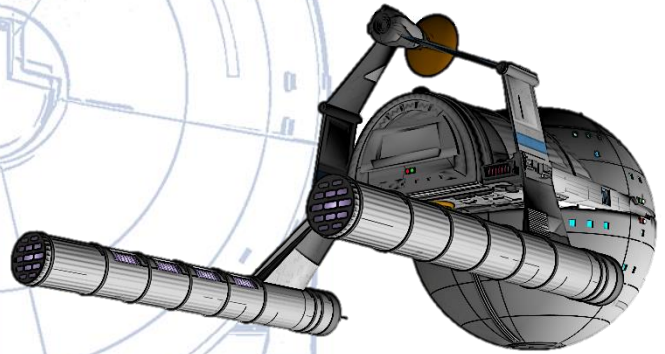

When the Lockley arrives at the location of the distress beacon signal, they find a large barren asteroid slowly drifting through space. Sensor scans of the asteroid's surface detect that a Confederation shuttle ship is indeed on the surface and the source of the signal. There is a high amount of ambient radiation coming from the asteroid that is currently preventing teleportation and the sensors from determining if any life signs are present. Near the shuttle several large caverns have been detected as well as an underground structure that appears to be artificially constructed.

Captain Watts directs Vanlan to prime the Lockley's shuttle ship for an excursion to the surface. Watts intends to lead the landing party himself and selects T'Shana, Randall Riley, and the PC's to accompany him. All members of the landing party are

instructed to wear a radiation suit with an oxygen tank as instrument readings indicate that the surface is radioactive and does not possess an atmosphere.

EQUIPMENT

Each member of the landing party will be provided a radiation suit with oxygen tank, a beam pistol or electro-stun gun, and a communicator for use on this assignment. In addition to this equipment, T'Shana will be equipped with an auto-analyzer and Riley will be equipped with universal translator.

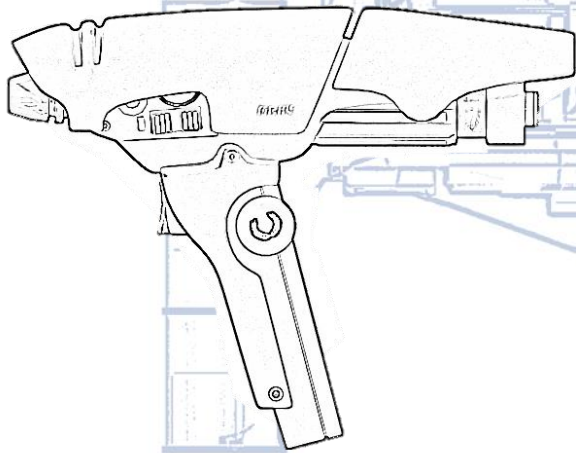

MISSION NPC'S

Captain Watts, acting Chief Engineer Vanlan, Security Chief T'Shana, Security Officer Riley, and the ship's service robot ED-2, who were introduced in the previous missions, will be available for use in this adventure. In order to successfully complete this mission NPC's Watts, Vanlan, and T'Shana must survive this adventure.

THE MISSING SHUTTLE

Upon landing the party will easily find the Confederation shuttle on the asteroid's surface inside the rim of a large shallow crater. The shuttle ship is unoccupied, appears to have endured a rough landing, and is damaged beyond repair. The shuttle's hatches are open, and all portable equipment has been removed. A set of several footprints, consistent in appearance with Confederation issue radiation suit boots, are visible in the dusty particulate covered surface. The footprints lead away from the shuttle towards a cavern entrance just below the rim of the crater.

#1 CAVERN ENTRANCE

The cavern entrance is a wide 30' x 20' opening in the Western side of the shallow crater that leads downward into a 10' high x 10' wide passageway in the rock. There is no natural light inside the cavern so the party will have to use artificial light or biological adaptations in order to see inside. Just inside the mouth of the cavern entrance are the skeletal remains of a Hykhot wearing a Confederation issue radiation suit with C.S.F. Lockley shoulder patches and the name "Grilfik" embroidered on a cloth patch attached to the chest plate of the suit.

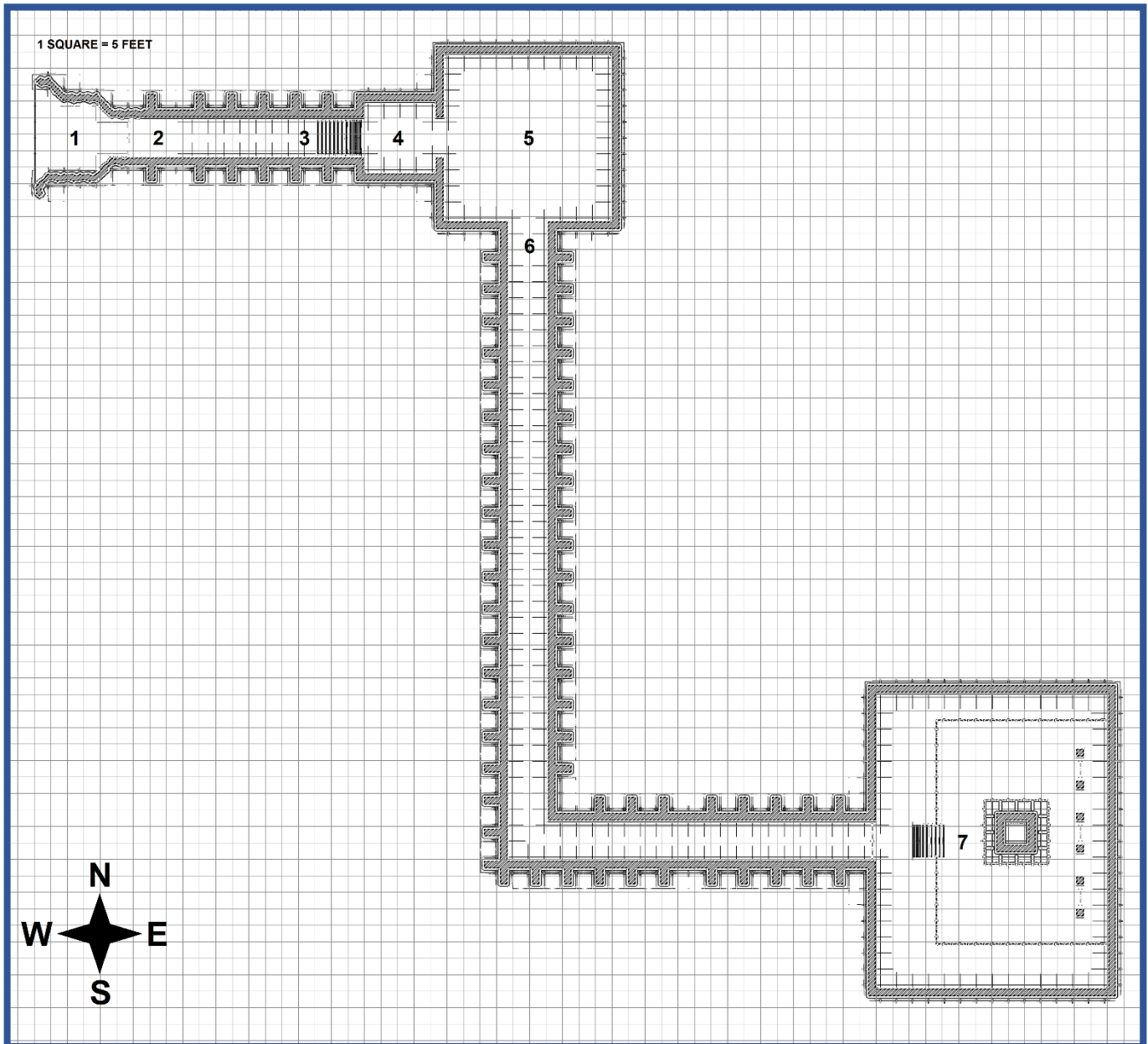

The amphibian's remains are found lying on its side on the cavern floor and appear to be long since dead. Captain Watts with a heavy sigh confirms the Hykhot as one of the missing crew that was on the shuttle. Watts remarks that it is strange that there would be this rate of decomposition on an asteroid with no atmosphere. Upon closer inspection of the corpse, Watts finds two long arrow shafts, shocking and strangely

out of place, protruding from the back side of the suit. The arrow wounds marking an obvious cause of the crewman's untimely death and indicating that he had indeed survived the shuttle's encounter with the cosmic gas cloud. Considering the unnatural state of his crewman and the obvious signs of foul play, Watts directs the party to ready their weapons.

SPACE MASTER: Auto Analyzer Device analysis of the arrow shafts will indicate that they are made of a common variety of terrestrial hardwood found on most Class-H worlds. The arrow heads are composed of Iron based metal alloys which have become badly rusted. The arrow parts are affixed to the shafts with a mixture of twine and animal sinew with trace remains of bird feathers for stabilizing fletches. Though ancient in appearance isotope dating confirms the archaic projectile is less than twenty years old by the Galactic Calendar.

#2 TUNNEL PASSAGEWAY

The cavern entrance gradually narrows into a 60' long 10' high x 10' wide tunnel-like passageway cut into the asteroid rock. While there are no indications of identifiable design the passageway is too symmetrical and level to have occurred naturally. Unusual 4' wide ribbed arches run the entire length of the passageway. The passage is completely dark with no sources of natural or artificial light present.

#3 STAIRWAY

The rocky tunnel-like passage in the asteroid rock suddenly ends in a carved humanoid sized stairway that descends deeper below ground. The stairway descends 40' below the surface of the crater bottom into the depths of the

asteroid. The bottom of the carved stairway opens into a 20' x 20' antechamber carved into the asteroid rock.

#4 ANTECHAMBER

The antechamber is a small 20' x 20' room hollowed out of the asteroid rock that connects to a larger room. The smooth symmetrical geometry of the walls indicates that its construction is both artificial and deliberate, designed to accommodate humanoid sized lifeforms. The room is dark with no natural source of light so artificial lighting, or biological adaptations, will be needed to see inside.

The walls of the antechamber are covered with strange unknown alien symbols, perhaps the ancient language of a lost culture.



#5 COUNCIL ROOM

At the far end of the antechamber is a large stone archway that marks the entrance of a 60' x 60' room with a tall 25' high "vaulted" style ceiling carved out of the rock. There are several raised blocks of stone with somewhat unusually carved angles and slopes found throughout the dark room. Like the antechamber before it, this room is also covered with unknown alien symbols.

Space Master: *Anyone in the party carrying a light emitting device, such as a flashlight or beam pistol set to illuminate, will be able to see boot tracks in the dust heading towards the second passageway.*



The room ends with another archway that leads into a second tunnel passage in the asteroid rock. Two massive Stone

Creatures (S&S-2E: Pg. #67) are hiding amongst the large blocks near the second passageway and will attack anyone that attempts to enter the second passageway.

STONE CREATURE	
Encountered:	3
Movement:	90', (30')
Intelligence:	Average
Psi Potential:	3d4, Inactive
Hits:	3d8
Armor:	-7
Combat Skill:	14
Save As:	Level 3
Attacks:	1 (Pummel)
Damage:	5d6
Morale:	N/A
XP:	65

#6 TUNNEL PASSAGEWAY

The first room connects to a L-shaped 300' long, 10' high x 10' wide, tunnel-like passageway identical in design to the one leading into the first room. While there are no indications of identifiable design, the passageway is too symmetrical and level to have occurred naturally. Unusual 4' wide rib-like arches run the length of the entire passageway. A third Stone Creature is hiding among the carved rock interior of the passageway walls midway down the tunnel. Like the previous two stone creatures this one will emerge from its hiding place and attack anyone who

approaches. Unlike previous sections of the structure, a faint green glow can be seen coming from the room at the far end of the tunnel. The dim glow of the distant light reveals more Confederation boot-prints in the dusty particulate surface leading towards the second room.

#7 PORTAL ROOM

The passageway opens into a large 80' x 80' square room with a 25' tall "vaulted" style ceiling cut out of the asteroid rock. A visibly glowing green energy field separates the passageway from the room. The shimmering energy barrier is a high intensity force field preventing entry from the passageway into the room. The field crackles with hair raising static electricity and produces a strong repulsive sensation that discourages touch. Contact with the field will cause 1d8+1 points of damage to anyone who touches it and will forcefully project them 1d6 feet away. The field appears to emanate directly from the rock walls with no emitter devices or visible technology present.

Inside the room several sets of Confederation boot-prints travelling in different directions can be seen in the dusty particulate matter covering the floor. While larger than the previous room, this one shares the same design features and alien inscriptions. In the center of the room is a large roughhewn 9' tall x 6' wide x 3'

deep black stone monolith covered with strange alien symbols. On the wall across from the entrance there are three large 10' tall x 6' wide x 4' deep rectangle shaped stone archways. Three long shafted arrows, identical to the ones found imbedded in the Hykhot's remains, lay scattered on the ground facing towards the entrance as if fired from someone standing behind the center archway.

From behind the monolith steps a middle-aged human male with stark white hair wearing unusual clothing decorated with the same alien symbols seen throughout the asteroid structure. The absence of any kind of encounter suit or life-support equipment suggests that a breathable atmosphere is present on the opposite side of the force field. The man is completely oblivious to the party standing behind the glowing force field as he mumbles words in an incomprehensible language to himself. The strangely dressed man loiters in front of the monolith before him, as if he were studying a map or reading a monument inscription. For a moment, the man's concentration drifts to the party behind the crackling green barrier. He tilts his head curiously to the side, smiles and gives the party a wink. Quickly the man turns his back to the party and approaches the center stone archway. He waves his hand with a sweeping gesture in front of the

great stones. A deep resonating low pitched noise fills the entire room raising the particulate dust inches off the floor as the symbols on the monolith behind him begin to glow.

Suddenly a brilliant flash of light erupts from the center of the archway revealing it to be a dimensional portal opening to a forested path on a distant unfamiliar world. The party sees the vague outline of a dozen humanoid figures standing among the trees near the path on the opposite side of the portal. Captain Watts catches a fleeting glimpse of Confederation Space Fleet uniforms worn by several of the people but is unable to distinguish their faces from behind the glare of the green force field. Some of the blurry figures closest to the portal seem to recognize Captain Watts, waving and pointing towards him. Captain Watts instinctively knows he is looking at his lost crew members standing on the opposite side of that portal.

The party watches as the unusually dressed man steps through the dimensional portal in the archway onto the forested path beyond. Looking back only briefly at the party held behind the force field as he joins the other figures waiting for him. A few moments later a brilliant flash of light comes from the center of the archway and the portal disappears, replaced again by

the view of the vacant rock wall. Shortly after the dimensional portal closes, the shimmering green forcefield disappears releasing the atmosphere held inside with a rush of wind.

Regardless of effort, the party will not be able to use the monolith control device or artifact portals contained in the Second Room at this time. While emotionally exhausted, this incident has once again renewed Captain Watts' hope that one day he may be reunited with his missing crew. In the meantime, Watts will report his findings to Space Fleet Command so that an alien contact team can be dispatched to study this structure and its artifacts.

ADJUSTING DIFFICULTY

If the Players are using intermediate level characters in this adventure the Space Master is encouraged to adjust the number of adversaries proportionate to the number and experience of the Player Characters participating. Space Masters are also encouraged to add random encounters and space hazards as described in the 2nd Edition Rules during travel or periods of inactivity whenever appropriate.

CONCLUSION

Successful completion of this mission involves deployment of the new navigation buoy, investigation of the distress call, and surviving the dangers of the hidden alien base. In addition to any XP earned for defeated adversaries, the SM should award the PC's 30 XP each for successfully catching the navigation buoy with the Lockley's tractor beam within three attempts. The SM should award a bonus of 10 XP for good roleplaying, teamwork, and problem solving during the adventure. Mission failure will occur if the new navigational buoy is not deployed and the secret of the hidden alien base revealed. The PC's should be docked all earned XP for the adventure if any of the required NPC's are killed or the PC's abandon their party.

