

# IMPERIAL ROMAN WARSHIPS 193–565 AD



RAFFAELE D'AMATO

ILLUSTRATED BY GIUSEPPE RAVA

NEW VANGUARD 244

---

# IMPERIAL ROMAN WARSHIPS 193–565 AD



**RAFFAELE D'AMATO**

ILLUSTRATED BY GIUSEPPE RAVA

# CONTENTS

Title Page

Glossary

Introduction

Chronology

Historical Background

    The Late Empire

    The Eastern Empire

The organization of the late imperial Roman Navy

    The Praetorian fleets

    The Provincial fleets

    The fleets of Justinian the Great

    Crews and command structure

Late Roman warships and boats

    The evolution of the *biremis-dikrotos-liburna*

    The evolution of the *triremis*

    The evolution of the *quadriremis*

    The *triakonteris*

    The *pentekonteris*

    From the *liburna* to the *dhromon*

    The *navis lusoria*

    Other ships

    Structure and construction

    Armament, equipment and decoration

Fighting on the sea: Late empire Roman Naval tactics

Operational History

    The Gothic Wars, 238–271

    The Persian campaign of Julianus, 363

# The Italian reconquest wars of Justinian the Great, 531–561

## Bibliography

Ancient Roman sources

Modern works

About the Author

Acknowledgements

# GLOSSARY

*Anquina*: double rope used to drop down the pennon when the mainsail was not in use

*Antennaeorantemnae*: pennons

*Aphlaston (aplustre)*: the raising of the stern

*Carina*: keel

*Cheruchi*: uphauls for the *vela*, bound at the top of the mast

*Cornua*: the knotted corners of the squared mainsail at the top

Foredeck: the deck forward of the *epotis*, and aft of the stempost

*Interscalmium*: The space between thowl and thowl on the side of a vessel, consequently represented on the outside by the space between one oar, or oarport, and another

*Gubernaculum*: rudder

*Maloorarbor*: mast

*Navis, naves*: ship, ships

*Puppis*: stern

*Rostrum*: ram

*Rudentes*: ropes

*Si para*: topsail

Stempost: the curved timber rising from the keel in the bow and culminating in an ornament or figurehead

*Stolos*: ornament of the prow

*Thalamites*: the lowermost oarsmen on a three-level warship

*Thranites*: rowers in the topmost reme in a multireme warship

*Trochlea*: tackles and blocks for the running of the ropes linked to the movement of the sails

*Velum, vela*: sail, pennon sail

*Wale*: assemblage end to end of thick and broad planks along a ship's side and worked into the hull planking

*Zygites*: middle-reme oarsmen on a three-level warship

# INTRODUCTION

The period of relative peace enjoyed by the Roman Empire in the first two centuries of its history ended with the Marcomannic Wars. While the Mediterranean and the rivers Rhine and Danube were the centre of Roman maritime operations, Roman fleets also operated in the Atlantic Ocean, in the English Channel, and in the Irish Sea and North Sea as far as the Orkney Islands and Denmark's northernmost cape. At the same time the Roman navy fought in the Black Sea, and on the Euphrates river as far as the Persian Gulf. Roman fleets were also present in the Red Sea, and probably also in the Indian Ocean.

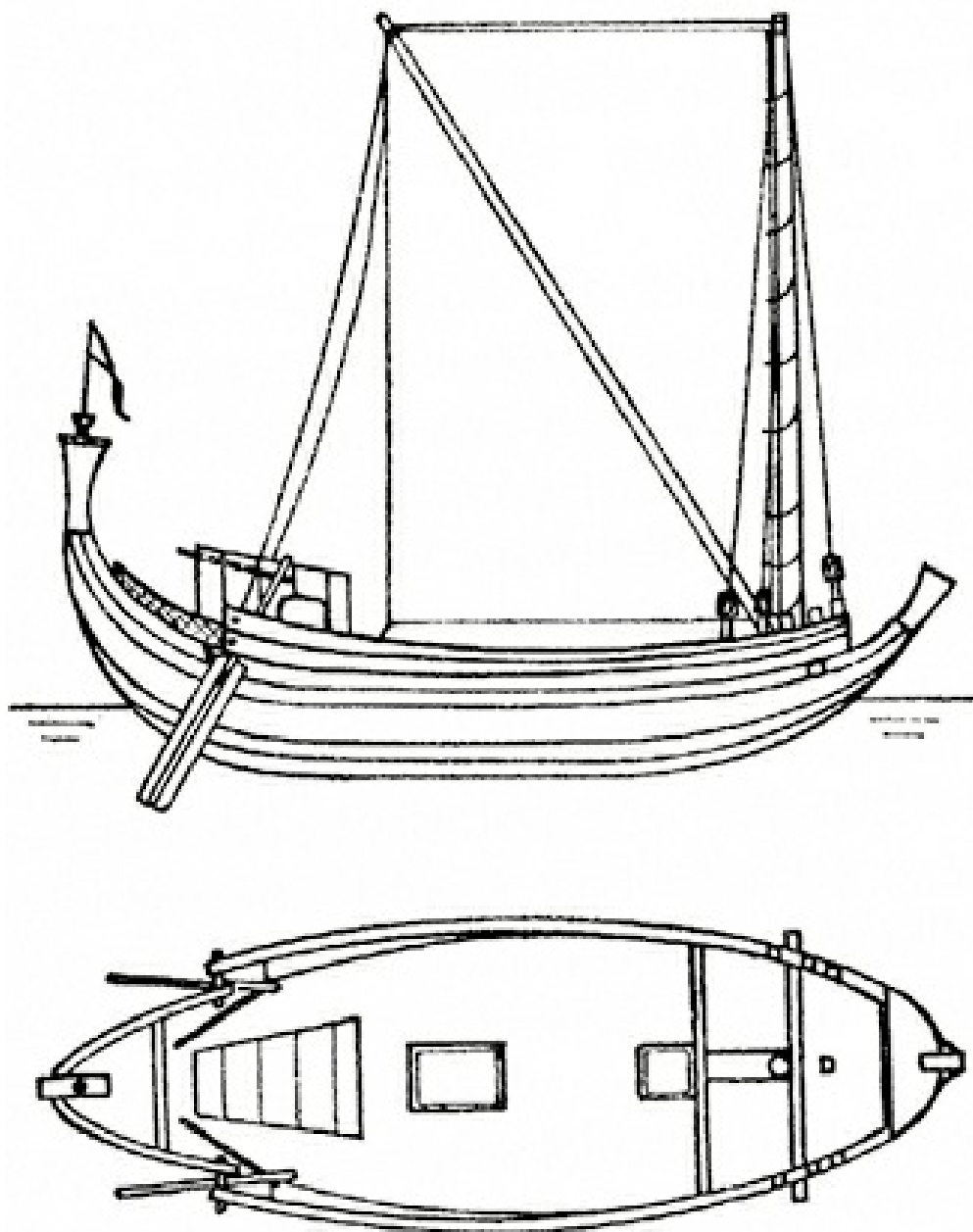

Reconstruction of a *navis oraria*, 2nd–3rd century. (Drawing by Andrea Salimbeti ex Viereck)

The advent of the Severian dynasty in 193 AD was followed by the third-century crisis of the Principate and the start of a period of military anarchy, which saw the Roman armies engaged in land and sea against Barbarian invaders and fighting bloody civil wars. Now seriously challenged by new dangers from the sea, the Roman fleets' role was no longer merely patrolling the *Mare Nostrum*, but also fighting invaders with naval power and the experience to attack them. The restoration of

Diocletian and Constantine did not prevent civil wars and the widespread use of the fleets, as well as naval operations as part of the unified Roman Empire's last major campaign, against the Persians, under Emperor Julianus.

The serious naval threat of Genseric and his Vandals highlighted the difficulties Rome had in creating and maintaining sufficient naval power to defend the Empire. In this the surviving Eastern Empire succeeded, and, at the death of Justinian the Great, the Mediterranean was again a Roman sea, sailed by the new protagonist of naval warfare for the next seven centuries: the *dhromon*.

This, the third New Vanguard volume examining the warships of Rome, [1](#) analyzes the evolution of the Roman fleet in one of the most fascinating periods of its history. New shipwrecks, archaeological discoveries and the very rich details of literary and artistic sources allow us a good reconstruction of the new giants of the sea in this tumultuous period.

[1](#) For the earlier history of Roman warships, see NVG 225 *Republican Roman Warships 509–27 BC* and NVG 230 *Imperial Roman Warships 27 BC–193 AD*

# CHRONOLOGY

**210 AD** The *Classis Britannica* supports the land operations of the Emperor Septimius Severus in Caledonia

**213** While sailing along the north Aegean coast, the Emperor Caracalla's ship is wrecked; a *galea* of the Imperial *Misenensis* Fleet rescues him, and the whole Fleet receives the title of *Pia Vindex*



Denarius of the Emperor Caracalla. On the obverse you can read *ANTONINVS PIVS AVG* (Antoninus Pius Augustus) and on the reverse, on the ship, *ADVENT AVGG* (*Adventus Augustorum* = arrival of the emperors). The galley presents a legionary *vexillum* on the prow, and a standard on the stern, with three passengers seated in cabin at the stern, probably Caracalla, Geta and their father Septimius Severus. The legionary flag at the prow and the legionary standards at the stern point towards the representation of a ship involved in some military expedition. The coin celebrates the delayed arrival in Rome of Septimius Severus in the year 202 AD with his two sons Caracalla and Geta. You can clearly see this galley's double-beaked ram, another sign of its military employment. (Mint of Rome, 202 AD, private collection, photo courtesy of Forum Ancient Coins)

**238–251** First Gothic war; sea and land raids by the Goths and pirate activities in the Black Sea; the *Legio II Adiutrix* receives from the Emperor Claudius II the appellative of *Constans*

**238** The Emperor Pupienus chooses Ravenna as operative base against Maximinus

**243** The Emperor Gordian III concentrates strong naval forces in the East and defeats the Sassanians

**260** The *Misenensis* Fleet suppresses an African revolt against Gallienus

**261** Continuous naval raids by the Saxons on the west coasts of Britain

In the Persian war the usurper Balista collects ships of Cilician ports and defeats the Persians near Pompeiopolis, taking the harem of the Sassanian King Shapur I (Zon., XII, 630; Syncellus, 7, 742–7,743)

**262–266** Moesia and Thracia under threat by the Goths; the Germanic Herulians' fleet of 500 ships is destroyed by Romano-Byzantine fleet before Byzantium. The Barbarians ravage Greece, sacking Athens, Corinth, Argos and Sparta; but the Athenian leader Publius Erennius Dexippus, with 2,000 men and the help of the Roman fleet, ambushes the Barbarians on their return journey; their army and fleet are finally destroyed by the Emperor Gallienus in Thracia





Roman *Hippagus*, from a third-century mosaic. (Medein, Tunisia, photo courtesy of the museum)

**263** In Gaul, during the 'Gallic Empire' of Postumus, a flotilla is established to guard the Upper Rhene-Danubius *Limes*

**268** The Roman *navarcha* Probus defeats Palmyrene army before Alexandria

**269** Second Gothic invasion by sea; Herulians, Borani, Goths and other Germanic peoples attack the Bosphorean towns under Roman control. A fleet of 2,000 ships and 320,000 men from the Danube enter Roman territory. Marcus Aurelius Claudius defeats the invaders by sea and by land. The Roman fleet is reconstructed

**270** The Borani Goths, after having armed the Bosphorean ships and recruited conscripts from the captive sailors, ravage the Pontic coasts as far as Trapezunte; Trapezunte falls and many Roman warships are captured

**278** The Isaurian Lidius (Palfuerius) undertakes piracy along the coasts of Asia, Pamphilia and Lycia; besieged in the city of Cremna of Pisidia by the Roman legions, Lidius does not hesitate to sacrifice men, children and women, until he is killed by a traitor who allows the Romans to enter the city

**279** The Frankish captives settled by the Emperor Claudius II in Pontus seize a number of ships and raid Greece and Eastern Sicily, to be destroyed by the Roman fleet near Carthage

**293–297** Constantius Chlorus restores Imperial authority in Britain in the wars against Carausius and his successor Allectus

**324** The Constantinian Fleet, under the command of Crispus, son of Constantine, destroys the fleet of Licinius in the waters of Byzantium, capturing the city and sinking 130 enemy ships

**363** Naval and land campaign of Julianus against the Sassanians

**399** Gothic attempt to cross the Hellespontus (Dardanelles) is thwarted by a Roman fleet of the Eastern Empire

**400** The Imperial fleet of Arcadius destroys the fleet of the Gothic *Magister Militum* Gainas

on the Marmara Sea

**Start of the fifth century** Pirate activity of the Mangones, slave merchants from Galatia, along the coasts of Roman Africa

**419 and 438** The Emperor Theodosius II forbids the divulging of the secrets of naval carpentry, probably to avoid its spread to the rising Vandal power in North Africa

**440** Sea and land forces sent by Theodosius II to the West

**445–450** 2,000 conscripts shipped on warships to Alexandria from Constantinople to put down ecclesiastical disorders

**457** The Western Emperor Majorian defeats a Vandal fleet under the command of a relative of King Genseric, near Sinuessa in Campania

**468** The combined fleet of Eastern and Western Roman Empires is destroyed by the Vandals of Genseric in the waters off Carthage

**533** The fleet of Justinian the Great transports the troops of Belisarius to Africa for the war against the Vandals

**551** An Ostrogothic fleet built in Italy and led by Totila successfully supports the invasion and recapture of Corsica and Sardinia against Roman naval power, but the Imperial ships destroy the Ostrogothic ships at Sena Gallica

# HISTORICAL BACKGROUND

## The Late Empire

The instability of the third century gave rise to a new and turbulent period for the Roman fleet. The emperors had to deal with the new danger represented by the Gothic sea and river raiders, and to fight against the new Persian danger represented by the Sassanians. Fleets were involved in external as well as civil wars.

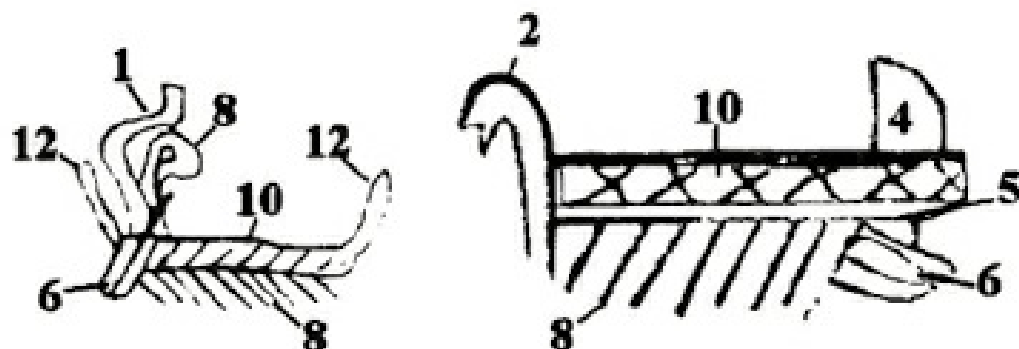

Diagram of the elements of a Roman third-century coin representing warships. (Drawing by Andrea Salimbeti ex Royal)

1. Aphlaston element
2. Bird
4. Stern structure
5. Wale, outboard gangway
6. Quarter rudder
8. Oars
10. Screen
12. Upward projection

The *Classis Misensis* (Misenum Fleet) was still a substantial one during the third century, able to send reinforcements to local units in difficulty during military operations. But during the Empire of Gallienus the need to form new land armies brought the neglect of the navy, which was losing men to the army. At the same time, for operations in the Mediterranean Sea and in the Pontus Euxine (Black Sea), the fleets were hastily put together from whatever ships could be manned; the old formal fleets gave way to locally operated squadrons. When Palmyra took gradual control of the East, the *Classis Syriaca* abandoned the Levantine coast and returned to the bases in Aegean, but the consequence was renewed pirate activity along the Cilician coasts. The Barbarian raids and the outbreak of piracy provoked the decline of Roman merchant activity in the Mediterranean and Euxine, while the closure of the Red Sea and the Persian Gulf to Roman shipping, due to Ethiopian and Persian pirate activity, permanently cut off Roman trade with India and China.



Denarius of the Emperor Geta. The galley presents a legionary *vexillum* on the prow of a *biremis*. The represented ship is probably a *biremis* of the *Classis Syriaca*. (Mint of Ephesus, 202–12 AD, Ephesus Archaeological Museum, author's photo, courtesy of the museum)

At the end of 280 many of the *Classis Germanica* ships had been laid up for winter maintenance, perhaps near Colonia Agrippina (modern Cologne). A sudden attack by the Barbarians destroyed the fleet on the shores of the Rhine. Pirate activity around the northern coasts of the Empire, especially Britannia, was constantly increasing.



The emperor Constantius Chlorus entering London, gold medallion, late third century AD. Most of the Late Roman warships are depicted with approximately ten oars per side. Given that the number of oars could be under-represented, this circumstance should indicate warships of about 18 to 20 metres in length. (London, British Museum, author's photo, courtesy of the museum)

By 285, when Diocletian was crowned emperor with the general Maximianus sharing his Imperial power, the provincial squadrons had been much reduced in all corners of the Mediterranean and the big Italian fleets had shrunk to mere skeletons; Carausius (Maximianus' admiral) had the responsibility of defending the coasts of northern Gaul and southern Britain from Frankish and Saxon raids, but was unable to deliver a decisive blow to the marauders until 287. However, by this time Carausius had rebelled and since 286 had ruled a personal Romano-British Empire, and it was not until Constantius Chlorus that Imperial power was re-established in Britain.

In 324, when Constantine the Great fought it out on the sea with one of his rivals and brother in law, Licinius, both sides had to use ships from the maritime cities of the East. But Constantine, whose father Constantius Chlorus had taught him about naval matters when he was facing the revolt of the *Classis Britannica* under Carausius, gave a new strong input to the building of a new fleet, mainly based on *moneres* types. After having established Thessaloniki (Greece) as a military harbour, he pushed on the building of 200 *triakonteres* and several *penteconteres*. He faced Licinius with a fleet on the south-west corner of the Dardanelles, and he owed his victory to the employment of the new light *moneres* that surpassed the heavy old *triremes* of Licinius.

From this moment onwards *triakonteres* and *penteconteres* were the ships that formed the nucleus of the Eastern Roman Fleet, and would be for two centuries. From around 350–450, naval activity was concentrated along the Rhine-Danube and British fronts, which resulted in the hardening of

border defences with mobile cavalry units to intercept incursions. The main activity of the *Naves Lusoriae* on the Rhine was patrolling the river and looking for possible German movements on the east bank. Military personnel, including officials, required greater overland and some riverine travel to reach areas of the European or Near Eastern hinterland. Ships primarily served a supporting role in the movement of troops and supplies (through the *annona* system, the Roman state finance system), but were less likely to be carrying emperors and other high military officials as regularly as in the previous period. Thus, with a larger amount of overland traffic, fewer such officials were seen in the Mediterranean, and likewise fewer of the elaborately outfitted Mediterranean warships that carried them. Warships frequenting ports in this latter period were more likely to be on patrol or escort duty.



Detail of a Roman warship of the *moneres* type. A decrease in the number of wales shown in warship illustrations may also support a trend for warships to become smaller from c. 250–450 AD. (Fountain mosaic, third century AD, Cherchell Museum, Tunisia, photo courtesy of the museum)

Soon after Constantine had founded his new capital in the East, the huge cargoes of Egyptian grain that used to go to the Tiber were diverted northward to the Bosphorus. The new route was far simpler than the old and there was no need for a fleet of such large freighters as had been necessary for Rome-bound cargoes. The run was so much shorter and easier that vessels could make two or even three round trips a season. The only difficulty was navigating the Dardanelles, and the Emperor Justinian, in the early part of the sixth century, solved this by building a big granary on the island of Tenedos near the mouth of the strait.



Warship used for wine transport, c.220 AD. (Rheinisches Landesmuseum Trier, photo courtesy Domenico Carro)

Rome was slowly abandoned to her fate, and in the fifth century a new and terrible naval danger arose: the Vandals. This Germanic tribe, which had expanded into North Africa, took to the sea, captured Sardinia and Corsica and other strategic islands, and in 455 even succeeded in sacking Rome. There was no one to stop them, although the brave Emperor Majorian gained some success on land and sea.

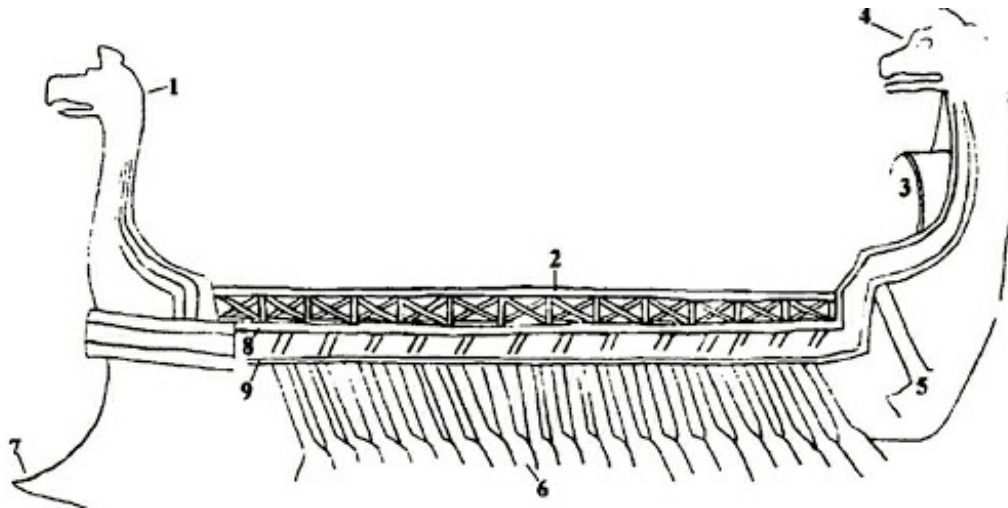

Diagram of the wine ship. (Drawing by Andrea Salimbeti ex Royal)

1. Zoomorphic head
2. Screen
3. Stern structure
4. Zoomorphic head
5. Quarter rudder
6. Oars
7. Ram
8. Sheerwale
9. Wale, outboard gangway

A united military expedition of the Eastern and Western empires ended in a naval disaster. In 468, the Western Emperor Procopius Antemius (467–472) and the Eastern Emperor Leo I (457–474) decided to destroy forever the power of the Vandals, and created the biggest fleet ever built by the Romans: 1,113 ships, comprising cargo ships and warships, on which were embarked 100,000 soldiers, sailors and marines. The supreme command was given to Basiliscus, brother-in-law of the Emperor Leo. The military action was consolidated from three different directions: the fleet should

have attacked the Vandal capital, Carthage, from the north, while two armies would have invested the Vandalic kingdom from the east (Egypt) and from the west. The operations began well for the Imperials: the general Marcellinus occupied Sardinia very quickly after an amphibious operation. The western attack continued on Mauretania, but the difficulty of the territory and the disturbance of the Moors pushed Marcellinus to reach the main Roman Fleet anchored in front of Carthage. Basiliscus, in fact, after having concentrated his giant fleet in Sicily and sunk 340 enemy ships, had reconquered the island. From the east, the Roman Army under the command of Heraclius and Marsus had conquered Tripolitania and Cyrenaica. Carthage was under threat. In the summer of 468 the Roman Fleet had arrived in the sight of Carthage, and it was there that the Imperial commander made his first and fatal mistake. He anchored the ships near the Eastern Cape, which was the best protected from the winds and from the storms, but also the farthest from the city. Genseric, the Vandal king, bought time by offering peace, conditions and money as a bribe to the Roman general. In the meantime, Genseric prepared his fleet, only 75 ships strong, but to which he attached incendiary barges, loaded with pitch, sulphur, oil and frayed fabric. The barges were without crew and towed by the other ships. When, after waiting for five days, the wind blew from the east, the Vandal fleet went out to sea, moving towards the Roman navy. As soon as the Vandal ships were in sight of the enemy, Genseric, who commanded his fleet personally, ordered the barges to be ignited with the incendiary materials. It was a key moment; the barges caught fire and, pushed by the wind, clashed against the Imperial ships, which burned like torches. The ships had been moored one beside the other, and the fire took hold very quickly. Basiliscus did not understand what was happening at the beginning, and he quietly ended his dinner. Procopius (DBV, I,7) says:

and as the fire advanced in this way the Roman Fleet was filled with tumult ... with a great din that rivalled the noise caused by the wind and the roaring of the flames, as the soldiers together with the sailors shouted orders to one another and pushed off with their poles the fire-boats and their own ships as well, which were destroyed one by another in complete disorder.



Silver *denarius* of the Emperor Eliogabalus. The coin shows a nicely detailed galley with sail and seven rowers plus a pilot. There is a round cabin in front of the pilot, and an imperial standard and aplustre on the stern, while a furled sail is mounted on the prow. The high curving object on the stern is the *acrostolium* of the ship. The presence of six rowing oars and a steering oar is common on coins, so we cannot take the number of rowers or oars as an indication of literal fact, but the ship probably represents the Imperial *liburna*. On the obverse you can read *ANTONINVS PIVS FEL AVG* (Antoninus Pius Felix Augustus) and on the reverse, on the ship, *FELICITAS TEMP* (*Felicitas Temporis* = happiness of the time). The pilot is inside a round cabin, which would have contained the emperor. There is a central mast with a 'crow's-nest', which served as a lookout point and a vantage for throwing missiles if it came to a battle. (Mint of Antiochia, 218–22 AD, private collection, courtesy of Forum Ancient Coins)

The Vandals in the meantime attacked the panicked Roman ships, killing sailors and soldiers. Marcellinus' fleet was able to escape from the disaster, however, while the Vandals were ramming



and sinking half of the Roman fleet. The other half was able to escape, Basiliscus with them, coming back to Sicily with only 500 ships. The Vandals were now the masters of the Mediterranean Sea. However, when their leader, Genseric, died in 477, their plunderings came to a halt. The naval power now passed to the Empire again.

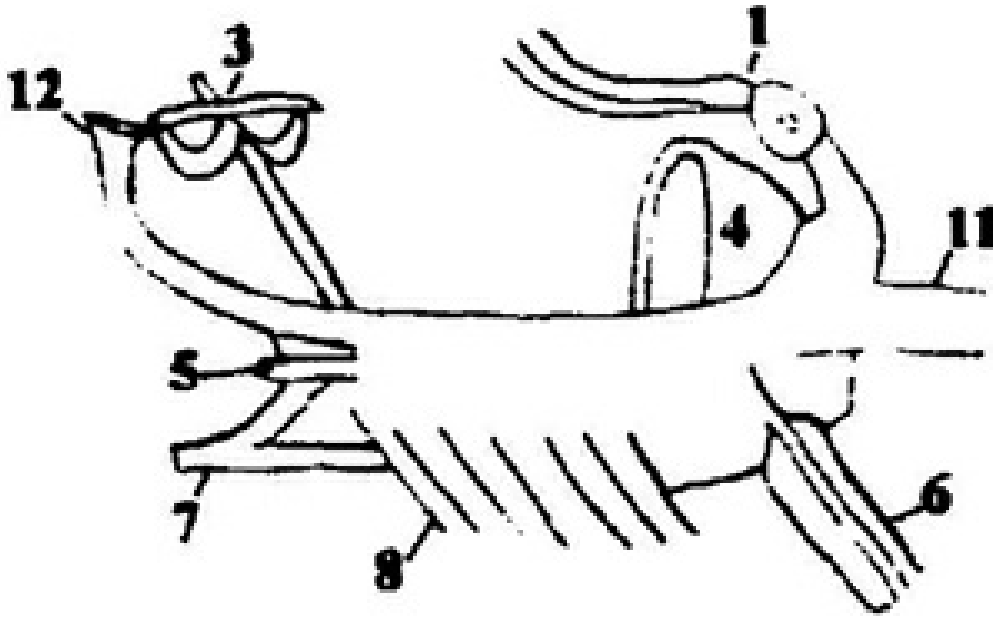

Diagram of the elements of a Roman third-century coin representing a warship. (Drawing of Andrea Salimbeti ex Royal)

1. Aphlaston element
3. Artemon
4. Stern structure
5. Wale, outboard gangway
6. Quarter rudder
7. Ram
8. Oars
11. Deck projection
12. Upward projection

## The Eastern Empire

One of the main historical reasons for the survival of the Eastern Roman Empire was sea power. After the fall of the West, the Empire's warships continued to protect Roman coasts against the Vandals and the Goths. Shortly after 500, the Empire launched a navy that managed to fill the gap left by Rome's naval collapse, and by the early sixth century the Emperor Anastasius began the reorganization of the Roman fleet. At that time the Empire had two dangerous enemies on the sea: the Vandal kingdom in Africa and the Sassanian Persians in the Arabian Gulf. Moreover, tension was growing between the Ostrogothic kingdom of Italy and the Empire.

In 508 an Eastern Roman fleet ravaged the coasts of the Ostrogothic kingdom. The naval performances of the Roman Empire continued in a civil war, in which the pretendent to the Imperial throne, the general Vitalianus, attacked Byzantium with a fleet of 200 ships in 515. Anastasius was not able to respond in kind, but in 516 an Imperial loyalist fleet, under the command of Marinus, routed that of the usurper.

In Justinian's wars against the Vandals, the Visigoths and the Ostrogoths, naval power was a decisive feature of victory. The reorganization of the fleet was one of the main factors in the victories of Belisarius. In 534 he reconquered North Africa for his emperor, winning the hand over the Vandal kingdom; his army of only 5,000 men was supported by a massive fleet.



Denarius of the Emperor Geta. (Mint of Ephesus, 202–12 AD, detail, Ephesus Archaeological Museum, author's photo, courtesy of the museum)

By controlling the sea routes and by cutting off sea operations linked to the communication and the transport of troops and supplies from his enemies, the *magistri militum* Narses and Belisarius were able to stretch Roman military power over great distances. After the reconquest, the Mediterranean was again Mare Nostrum: the Empire was now a strong maritime construct, based upon coastal regions and ports that need to be supplied and reinforced by the sea. As part of Justinian's revised taxation system, certain cities or regions were deputed to build ships for the navy, and until the arrival of the Arabs the Roman Empire was again master of the Sea.



The scene represents the *proto-dhromones* and the imperial *liburnae* under attack by Vandals. The ships have been copied from the Vergilius Romanus and Vergilius Vaticanus manuscripts as well as from the *De Re Militari* illustration preserved in the Bodleian Library: note the colourful decoration of the galleys and the painted mast surmounted by a cross. The *dhromones* are of *moneres* type. By the fifth century this was a single-banked ship-of-the-line in the Roman navy with a full fighting deck that also served to reduce the chance of rowers being hit by enemy missiles. Priscus' description of 11 rowers per side for these warships in the fifth century suggests they were smaller vessels of approximately 15m in length. Iconographic evidence also substantiates the smaller size of vessels after the mid-third century. Such smaller vessels support the hypothesis that warships were decreasing in size from those of the second and third centuries. Smaller ships would have been both swift and manoeuvrable, features that correspond well with the two primary characteristics of the *dhromon*. During the defeat of the Roman fleet in 470 by the Vandals, the Roman general John stood on the deck of his ship, crossing from side to side, and fought the Vandal vessels that had surrounded his own. From such accounts it appears that decks spanned the width of at least some portions of the hull and across its length entirely. Rowers sitting under a full deck would have been protected from projectile fire and also hidden from view.

# THE ORGANIZATION OF THE LATE IMPERIAL ROMAN NAVY

The organization of the whole army, as well as that of all public affairs, underwent serious modifications with the Tetrarchic Age that followed the crowning of Diocletian. These transformations were accelerated after the transfer of the Empire's capital to the East under Constantine, with the consequent eastward shift of the Empire's main interests.

The main document that allows us to reconstruct the situation of the Roman navy in the late fourth century is the *Notitia Dignitatum*, an arid but enlightening catalogue of the main public offices existing in both the Western and Eastern parts of the Empire. From this catalogue a clear trend towards dispersing Roman maritime forces can be inferred, as well as the absolute priority given to fleets operating on rivers and lakes over those fighting on the sea. Clearly, this concern was derived from the increasing pressure of the Barbarian migrations from the north, but the result was an excessive slack in the control of the seas (the Mediterranean, Black Sea and English Channel), which then constituted the most insidious way for the Barbarians to penetrate into the vital points of the Empire.

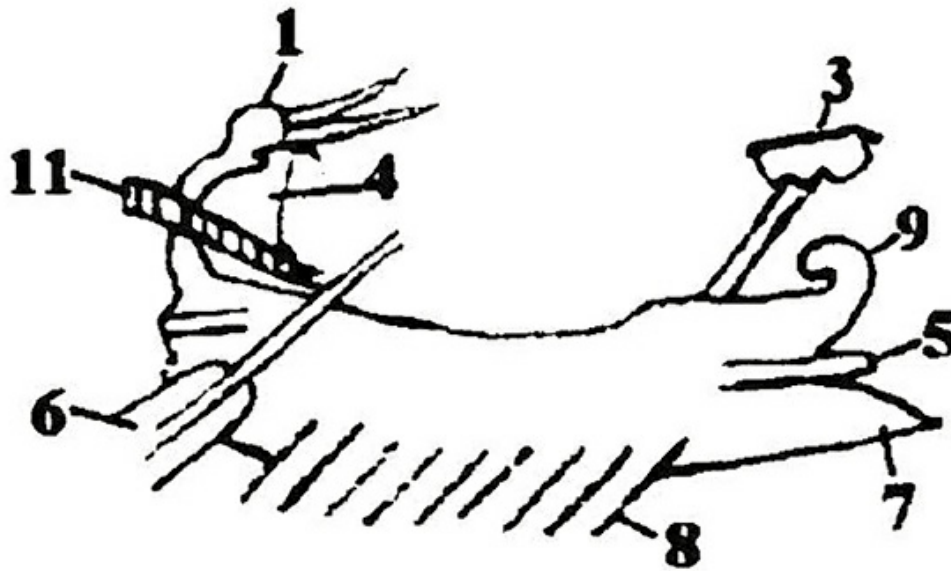

Diagram of the elements of a Roman third-century coin representing a warship. (Drawing by Andrea Salimbeti ex Royal)

1. Aphlaston element
3. Artemon
4. Stern structure
5. Wale, outboard gangway
6. Quarter rudder
7. Ram
8. Oars
9. Goose head
11. Deck projection

## The Praetorian fleets

The Praetorian fleets were, like in the previous age, under the command of a *praefectus*. The commander of the Misenensis Fleet was, because of the importance of the fleet, the supreme commander of the Roman navy. The *SHA* (Caracalla, V.1–7.1) remembers for instance the figure of Marcius Agrippa, *praefectus* commanding the Misenensis Fleet during the time of Caracalla, who rescued the emperor in danger during a shipwreck; together with his bodyguard, he had to climb down

into a lifeboat and was then saved by a *triremis* of the *praefectus*. The same Marcus Agrippa was later involved in the murder of the emperor.

The Praetorian fleets continued to exist at least until 395 in the East and 430 in the West. In Italy, however, four fleets are mentioned in the late fourth-century *Notitia*: the *Misenensis* (*Classis Misenatium*) at Misenum, the *Ravennatis* (*Classis Ravennatium*) at Ravenna, and two river and lake fleets: the *Classis Venetum* at Aquileia and the *Classis Comensis* on Como.

## The Provincial fleets

During the terrible years of the third century, the provincial fleets and bases underwent a tough test. The *Classis Moesica*, the *Classis Pontica* and the *Classis Syriaca* were the most engaged in battling the Gothic danger. During the Gothic invasions, there still was a Roman fleet and garrison in Chersonesus, but the Romans had lost effective control of the North Euxine basin.

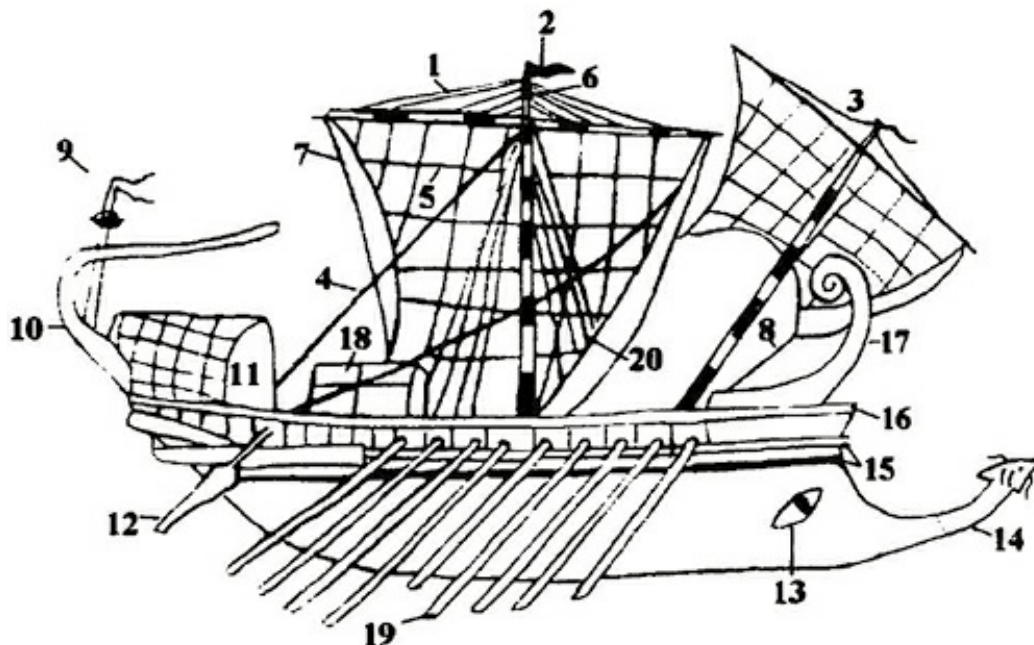

Diagram of the same ship. (Drawing by Andrea Salimbeti ex Royal)

1. Lifts
2. Banner
3. Artemon
4. Backstay
5. Brails
6. Mast
7. Brace
8. Sheet
9. Standards
10. Inward projection
11. Stern structure
12. Quarter rudder
13. Oculus
14. Ram
15. Wales
16. Sheerwale
17. Upward projecting structure
18. Structure
19. Oars
20. Shrouds

The reforms of Diocletian and Constantine, mirrored in the *Notitia Dignitatum*, gave new impulse to the re-establishment of the provincial fleets. The numbers involved in the provincial fleets, according to the *Notitia*, were huge. In Gallia, as in Italy, four fleets are mentioned: the river fleet of the Rhone

(*Classis Fluminis Rhodani*), located at Vienna (nowadays Vienne) or in Arelate (nowadays Arles); the lake fleet (*Classis Barcariorum*), patrolling Ebrudunum of Sapaudia (probably the Yverdon of today, on Lake Neuchâtel in Switzerland); the Saône river fleet (*Classis Araricae*), at Cabaliodunum (the nowadays *Chalon-sur-Saône*); and the river fleet on the Seine (*Classis Anderetianorum*), at Lutetia Parisiorum (now Paris).



Roman *ponto*, *Classis Nova Lybica*, early third century. (Mosaic from Carthage, Tunisi, Bardo Museum, author's photo, courtesy of the museum)

In Britannia, apart from the *Classis Britannica*, the small river fleet on the Tyne Estuary (*Numeri Barcariorum Tigrisiensium*) was still based at Arbeia (South Shields), a port at the eastern end of Hadrian's Wall. In the Provincia Belgica Secunda, the river fleet of the Somma (*Classis Sambricae*) operated, while in Raetia, near Confluentia or Brigantium (nowadays Constanza and Bregenz, on Lake Constance), there was the small lake fleet of the *Numeri Barcariorum*.

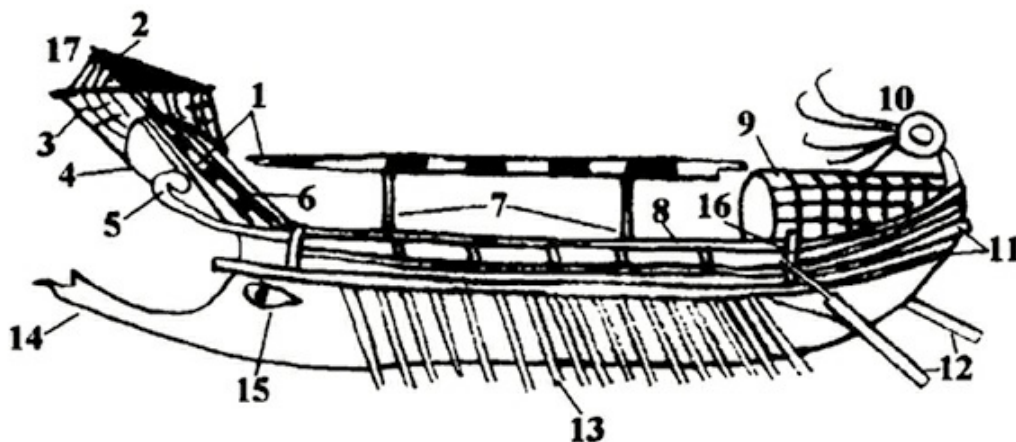

Roman *ponto*, *Classis Nova Lybica*, c. 200–20 AD. The bow shape is concave, the stern shape is convex, square rig. (Mosaic from the baths at Themetra near Hadrumetum, Carthage, Tunisi, Bardo drawing by Andrea Salimbeti ex Royal)

1. Masts
2. Lifts
3. Brails
4. Sheet
5. Forward projectile volute
6. Shrouds
7. Masts crutches

8. Railing screen
9. Stern structure
10. Aphlaston
11. Wales, outboard gangway
12. Quarter rudders
13. Oars
14. Ram
15. Oculus
16. Quarter rudder
17. Artemon

Along the Danube (then known as the Istrum) and its major tributaries, there were no fewer than 15 different naval units, scattered among seven provinces. A detailed look at the fleets on the river Sava, a Danube tributary, provides the following information from the highest point of the river downwards: the Second Pannonian Fleet (*Classis Secundae Pannoniae*), based on Siscia (nowadays Sisak); the First Pannonian Fleet (*Classis Primae Pannoniae*), patrolling Servizium (possibly now Bosanska Gradiska); the Secunda Flavia (*Classis Secundae Flaviae*) was stationed at Graium, inside the Pannonia Secunda; and the Flavia I (*Classis Primae Flaviae Augustae*) defended the Imperial city of Sirmium (nowadays Sremska Mitrovica).

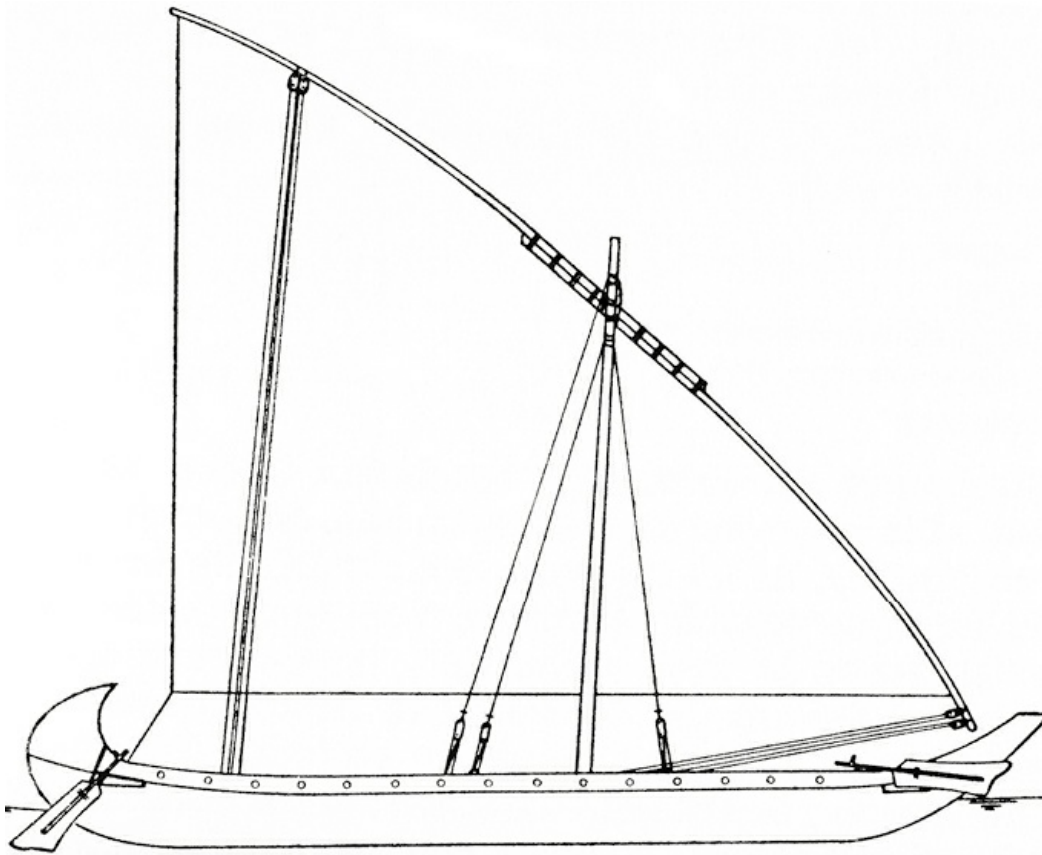

Reconstruction of a ship for marines' transport, fifth century AD. (Drawing by Andrea Salimbeti ex Viereck)

On the Danube itself we find the Istrica Fleet (*Classis Histrica*) divided into five small squadrons located at Vindobona (now Vienna) or Carnuntum (slightly north of modern Bratislava) in the Pannonia Prima; at Florentia in the Provincia Valeria; at Mursa (nowadays Osijek) on the last stretch of the Drava before its confluence with the Danube, in the Pannonia Secunda; at Viminacium in the Moesia Prima; and at Egeta, nowadays Brza Palanka, in the valley of the Iron Gates in the Dacia Ripensis.

The Roman fleet on the Danube was completed by the *Classis Lauriacensis* (on the now-Austrian stretch of the river) in the Pannonia Prima and the *Classis Arlapensis* et *Maginensis* based in Arelape

and Commagena (nowadays Pöchlarn and Tulln), north of Vienna; the Margo's fleet (*Classis Stradesensis et Germensis*) in the Moesia Prima; and the fleet of Ratiaria in the Dacia Ripensis, nowadays Archar in Bulgaria. The structure of the western fleets is completed by the *Classis Ratianensis*, on the Moesia Secunda, by the Transmarica (*Navium amnicarum*) in the Scythia, and finally, on the river delta, the Inplateypegiis Fleet (*Classis musculorum Scythicorum*).

In Africa, the *Classis Nova Lybica* survived until the half of the third century. It then disappeared in the chaos of the third-century civil wars, and reappeared in the Tetrarchic Age in another form and name.

The *Classis Augusta Alexandrina* was one of the most important and active fleets in the Late Roman Age. During the civil war between Constantine and Licinius the latter could rely upon 80 ships of the *Classis* (Zosimus, II, 22).

By the beginning of the fifth century, the fleets of the North Sea and lower Germanica were abandoned, leaving only the major fleet bases at the ports of Carthage, Aquileia, Como, Ravenna, Misenum, Arles, the mouth of Somme, and Alexandria. Naturally, since 330 a new military harbour had also been established in the new Imperial capital of Constantinople.

## The fleets of Justinian the Great

The fleet created by Anastasius in 516 to confront the naval menace of Vitalianus became the core of the great standing navy of Justinian. To maintain his Mediterranean thalassocracy, or maritime empire, the emperor transformed the bulk of Marinus' fleet into a permanent professional navy, a large force destined to support the invasion forces of the Empire in Africa, Spain and Italy. Fleets were also requested for patrolling large areas and reinforcing trouble spots.



Roman warships, 3rd–4th century AD, mosaic of naval battle, from Cirta, Constantine, Algeria. The warships are shown without sails but they may not have lacked them; rather, the ships are depicted in an attack manoeuvre where sails and masts were lowered while under oar. Furthermore, although warships were sometimes depicted with a single sail, the vessel was undoubtedly outfitted with two masts. For example, an *artemon* is often shown alone in the naval iconography of the period from 250 to 450, but must have been part of a two-mast arrangement, since it is shown in conjunction with main masts in all other depictions. It would be prudent and logical for warships to carry sail in order to save the oarsmen's energy for naval engagements, and to provide a greater travelling range for longer periods of time. (National Archaeological Museum, Algiers, photograph courtesy of Professor Oulmi Med Lakhdar)

The numbers given by Procopius (BV, I, XI,7–16) for Belisarius' expedition in Africa in 533–534 are impressive; the whole force was composed of 500 ships, no one of which was able to carry more than 50,000 *medimni*, nor any one less than 3,000 (the *medimnus* equalled one-and-a-half bushels). The vessels were manned by 30,000 sailors, Egyptians and Ionians for the most part, and Cilicians, and the supreme commander appointed over all the ships was Calonymus of Alexandria. Ninety-two of these ships were warships equipped for sea fighting, the *dhromones*, manned by 2,000 Byzantines (i.e. sailors from Constantinople), who were all rowers and fighters. If this is true, it means 21–22 men manned each *dhromon*. If this was also true for the *proto-dhromones* of Teoderich mentioned by



Cassiodorus, the total number of Ostrogoth sailors should have been *circa* 20,000 men.

1a



1b



Coin of the Roman usurper Allectus, *quinarius* in bronze. On the obverse (1a) you can read *IMP. C. ALLECTUS P. F. AVG.* (Imperator Caesar Allectus Pius Felix Augustus) and, on the reverse (1b), on the ship, *VIRTUS AVG. QL.* (Virtus Augusti Quinarius Londinium = emperor's virtue mint mark of Londinium). The sketch of the galley is very similar in detail to that shown on the Low Ham mosaic, and therefore can give us some indication of the type of the single-level vessel in use near the *Classis Britannica*. (Mint of Londinium, 293–96 AD, private collection, courtesy of the owner)

## Crews and command structure

The command structure of the Imperial navy from the third to fourth centuries was organized in a similar manner to that of terrestrial military units. From the point of view of the Imperial administration, fleets were regarded as part of the army through the mid-fourth century, with a *magister militum* in charge of both land and sea forces. Typically, a fleet of ships would have come under the direct command of a *praefectus*, while a centurion, together with his subordinate *optio* and *armorum custos*, would have commanded an individual ship. An example of an officer commanding both land and sea forces was the *dux litoris Saxonici*, who was elevated to *comes* of the *Classis Britannica* probably during the visit of the Emperor Constans II (337–350) in 342–343. The holder of this military post was both a commander of the fleet and also of the associated forts on both sides of the English Channel. Individual fleets remained under the command of *praefecti* well into the fifth century. Calonymus of Alexandria, commander of the fleet of Justinian, still had the rank of *praefectus* in the sixth century.

2a



2b



Coin of the Roman usurper Allectus, *quinarius* in bronze. (Mint of Londinium, 293–96 AD, private collection, courtesy of the owner)

# LATE ROMAN WARSHIPS AND BOATS

In this period the distinction continued between *naves longae* and other ships – with the first word mainly indicating warships. The warships could be either deck covered (*cataphractae* or *constratae*) or not (*apertae*). They were mainly of two categories: *moneres*, i.e. with only one line of oars, or, very rarely, fitted with more rows of oars. From the third century onwards, the main iconography shows most warships with a single bank of oars. The *moneres* of the third and fourth centuries were the *triakonteris* (*triakontore*, *triakonteres*) and the *penteconteris* (*pentekontore*, *pentekonteres*); in the sixth century the *dromo* or *dhromon*, light and heavy. But in the age of Justinian there were also *dhromones biremes*, i.e. with two rows of oars. Seagoing warships and river warships were also of different types.



The legend of Odysseus, representing Odysseus and his crew on a Roman *liburnica biremis* of the *Classis Alexandrina*. The mosaic shows many important elements of a third-century warship: note the decorative representation of the oarbox and the oars protruding from below the box and not from within it. (260 AD, mosaic from Dougga, Tunisi, Bardo Museum, author's photo, courtesy of the museum)

At the beginning of the fifth century, the *moneres* was the predominant design type, no matter whether the warship was conceived for fighting on the sea or on rivers. Its construction was mainly a state affair, but it was soon also open to private contractors. There are well-documented trends in merchantman-building activity, in which private capital investment incentivised the private warship-building industry. The decrease in material and labour investment by the Emperor would have allowed private merchants to build warships more cheaply, or more privately-built ships could be built for a given amount of financing.



The legend of Dionysus and the pirates, representing a Roman *biremis* of the *Classis Alexandrina*, mid third century AD. (Mosaic from Dougga, Tunisi, Bardo Museum, author's photo, courtesy of the museum)

## The evolution of the *biremis-dikrotos-liburna*

The *liburna* was still the main ship of the Roman fleet, mainly but not exclusively used for war. An Egyptian papyrus of the third century mentions a *liburna* used for goods transportation on the river Nile. In 399 a fleet of Roman *liburnae* stopped a Gothic attempt to pass the Hellespontus, which means that at that time the *liburna* was still the main ship of the Imperial fleet.

*Liburnae* were mainly built with a single bank of rowers, but the *biremis* was also still employed. J. G. Royal suggests that the last representation of *biremes* in service is on Trajan's Column. According to the present author, the existence of iconography showing ships with two banks of oars during the third century is proof that two-level-oared warships were never abandoned, although they were very rarely used until their reappearance in the sixth century with the powerful *dhromon biremis* of Justinian's fleet. The aspect of these *liburnae* can be seen on the mosaic of the naval battle of Cirta: decked (*cataphracta*) to protect the rowers – maybe more from the weather and swell than from the enemy – with a high prow and a late shape of boxing for the oarsmen. The less elaborate *liburnae-biremes* were similar in shape to the type shown in the *Notitia Dignitatum* manuscript, the so-called *invincibilis liburna*, which represents an evolution of those on the Trajan Column.



Model of a river *liburna*, in bronze, third century AD. Military vessels were constructed for speed and manoeuvrability under oar, hence they had fine entries and exits, with softer bilge chines, than the utility and merchant vessels used on the river systems of Europe. One common feature was their higher length-to-beam coefficients than those of contemporaneous Mediterranean river vessels. The shapes of river warships followed many of the trends of Mediterranean seagoing vessels, changing from the rounded cross-sectional shapes of the second century to the flatter bottoms and sharper bilges by the fourth century. (National Museum Požarevac, author's photo, courtesy of the museum)

## The evolution of the *triremis*

This ancient warship, which for 1,000 years had formed the core of the Greek, Phoenician, and Roman fleet, was still widely used until the fourth century. We have mention (CIL XIII, 3564) of the *Radians*, a *triremis* of the *Classis Britannica*, at the beginning of the third century. The last battle of the *triremes* was fought in 324, at the western corner of the Dardanelles, and lost. Zosimus lists the various fleets sending such warships to Licinius in his fight against Constantine:

When Licinius heard of Constantine's preparations, he sent messengers throughout his realm bidding them make ready war-ships, infantry and cavalry. The Egyptians immediately sent 80 triremes, the Phoenicians as many more, the Ionians and Dorians in Asia 60, the Cyprians 30, the Carians 20, the Bithynians 30, and the Africans 50.

The more advanced *moneres* (*triakonteres* and *pentekonteres*) of Constantine were fighting in a more modern way, which Licinius' *triremes* could not withstand. The velocity and the greater manoeuvrability of Constantine's *moneres* allowed them to encircle and destroy the obsolete *triremes*, although the more heavily armoured. Since the fourth century, after this battle, the *triremes* are not mentioned in the fleets of the Eastern Roman Empire

Interestingly, near the *dhromones*, the fleet of Teoderich the Great, Ostrogothic King of Italy, also included some *triremes* (*triremis vehiculum*). But we do not have any evidence of *triremes* in the Eastern Roman Fleets of the fourth to sixth centuries.



Silver Antoninianus of Postumus. The warship shows four rowers, six oars, and the steersman sheltered by the tall, curved *acrostolium*. It is possible that the ship is the representation of a river *liburna* used against Franks and Alamans by the 'Gallic Empire'. The inscription on the obverse reads *IMP C POSTVMVS P F AVG* (Imperator Gaius Postumus Pius Felix Augustus) and, on the reverse, *LAETITIA* (happiness). (Mint in Colonia Agrippina, 260 AD, private collection, photo courtesy of the Forum Ancient Coins)

As with the *liburna*, the last shape of the *triremis* was different from the previous types. According to Royal, by the Late Empire the term *triremis* could not have referred to three-banked warships. But, to counter this thesis, the fact that the overwhelming majority of available evidence during this period refers to warships with a single bank of oars does not mean that *triremes* were not produced any more. Casson argues that since only the most prestigious and powerful ships were represented on coins, and that since these single-banked vessels were the type most often depicted, these ships were thus the largest and most powerful vessels in the Roman fleet, even larger and more powerful than *triremes*. If Casson's theory is reliable, it means that *triremes* were three-banked warships in this period, but that some single-banked warships were of considerably larger size. Opposed to the theory suggested by Royal, that artists never represented *triremes*, there is the evidence of some iconography, like the ships with three-bank levels clearly visible in the Vergilius Vaticanus. So we should agree with Royal on the fact that the representations on coins provide particularly strong evidence for warship types, and the overwhelming numbers of them are shown with a single bank of oars, and that therefore these were the kind of ship most common in the fleet, but from the other side we have the iconographical proof that *triremes* were still built and represented with their three banks of oars. In any case, Zosimus wrote that by the fifth century the *triremis* was no longer built.

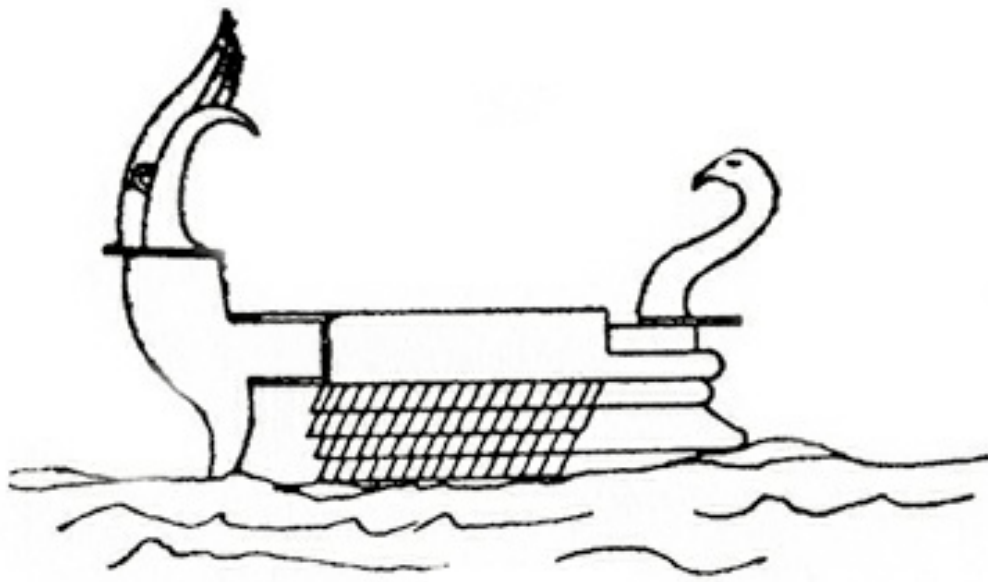

Medallion drawing of Gordian III representing a *quadriremis* . (Second quarter of the third century AD, drawing of Andrea Salimbeti ex Viereck)

## The evolution of the *quadriremis*

A further multi-banked warship in service is attested in the first half of the third century. A medallion of the Emperor Gordian III, minted in the fourth or fifth decade of the third century, shows a warship on which are visible four rows in an oarsection, which, although it is still under discussion, in all probability means that the rowers of both top rows sat on the angle of a plank-built thwart. This is the last image we have of a *quadriremis* of the Roman fleet, perhaps the representation of an Imperial flagship. In this *quadriremis* it is possible that the disposition of the rowers was the following one: the Thranite oarsmen and the Zygite oarsmen – respectively the oarsmen rowing in the highest level and those placed in the middle bank of rowers – were manning each oar with two rowers.

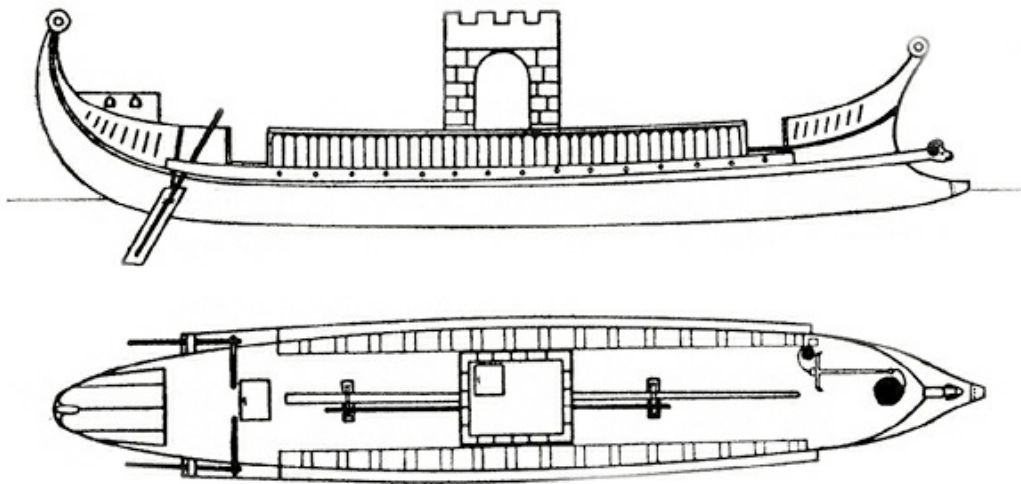

Reconstruction of a *triakonteris* of Constantine the Great, 324 AD. (Drawing by Andrea Salimbeti ex Viereck)

## The *triakonteris*

This ship was a medium-heavy *moneres* for sea warfare. At the beginning of the fourth century, the Roman fleet built mainly ships with a single row of oars, i.e. *moneres*. Some authors suggest that this kind of ship was developed in the second quarter of the third century by Carausius, in his role of

commander of the *Classis Britannica*, for his fight against the Saxon, Frisian and Anglian raiders. Maybe he was inspired by the open warships of Germanic origin manned by his enemies, like the Nydam ship recovered in Denmark. Whether this is the case or not, the agile Germanic *moneres* were the hitherto customary Roman types in command operations, and were notably superior in warfare in the North Sea and English Channel. In this age as in all the ages of maritime history, manoeuvrability and seaworthiness were fundamental factors for the warships, and in the third and fourth centuries sea warfare tactics in the North Sea were based mainly on agility and speed. So the construction of new types of ships that possessed such qualities began to be the priority. It is not therefore impossible that the building of the *triakonteris* was the Roman answer to the similar *moneres* managed by the Germans and that they were built following the Germanic prototypes, but perfected by the Roman Naval expertise. Very soon these light and small ships were employed also in the Mediterranean Sea.



Billion *Centenionalis* of Constans II. On the obverse runs the inscription *D N CONSTANS P F AVG* (Dominus Nostrus Constans Pius Felix Augustus). The emperor is in military dress standing left on galley left, holding a radiant phoenix on globe and *labarum*. The Victory sits at the stern and steers with the rudder. Galleys, or parts of galleys, were often shown on an unrealistically small scale in order to represent their presence but still allow important characters to occupy the largest part of the design. The structure of the galley, probably a *triakonteris* of the Imperial fleet, is faithfully represented, with the ram, the ports for the oars, and the three-part rudder all clearly shown. (Mint of Antiochia, 348–500 AD, private collection, courtesy of Ancient Forum Coins)

The *triakonteris* was, from the tactical point of view, the successor of the *triremis*. It was propelled by 30 oarsmen, 15 on each side of the ship. This structure recalls strongly that of the Nydam ship. The *triakonteris* was probably around 24.5m long and 4.30m wide, with a draught of 0.8m, against the 22.84m and 3.26m of the Nydam ship. Moreover, the Roman *triakonteris* was heavier than the Germanic ship because of its deck. Its reconstruction is possible thanks to a *foliis* (coin in bronze) of the Emperor Constantine, minted in 327.

## **The *pentekonteris***

This ship appears in 324 as a heavy sea battleship. Its characteristics show the heavy sea battleship of the Late Empire to be smaller than those of previous centuries. Its rowing system counted around 50 men, so it was a *moneres* with 25 oarsmen on each side. Taking into consideration the usual Roman *interscalmium* of 0.925m, this ship was about 32m long and 4.50m wide. Its draught should have been a little more than 1m.

The *pentekonteris* was, from the tactical point of view, the successor of the *quinquireme*, which was probably dismissed during the third century. In the relatively small *triakonteres* and *pentekonteres* of the Late Empire, which were fitted with a single row of oars, each oarsman manned only one oar. These battleships in fact took their names from the numbers of the oars, 30 for the *triakonteris* and 50 for the *pentekonteris*. Any change of name would have been dependent on

changes in design typology, in the propulsion given by the oars and by the sails.

## From the *liburna* to the *dhromon*

From the *liburna* evolved the *dhromon*, or *dromo*, which translated means simply ‘the runner’. It was designed, as its name shows, particularly for speed, and it was always *moneres* (single-banked) or two-banked (i.e. with two levels of oars). It appears as a fighting ship on the river Po in Italy, but since the fifth century it had already become the main ship used by the fleets of the Western and Eastern Empires. According to Viereck, the battleships of this period were characterized by their speed, as the name given to this ship seems to prove.

A fragment of a history attributed to the historian Eunapius of Sardis (349–414) mentions the *dhromon* for the first time. He describes the employment of 30-oared warships, called *dromades*, and built in the form of *liburnae*; as correctly pointed out by Angus Konstam, they were thus a new variant of the *liburna*. So probably the *liburna* continued to be built for a certain period beside its new variant, the *dhromon*.

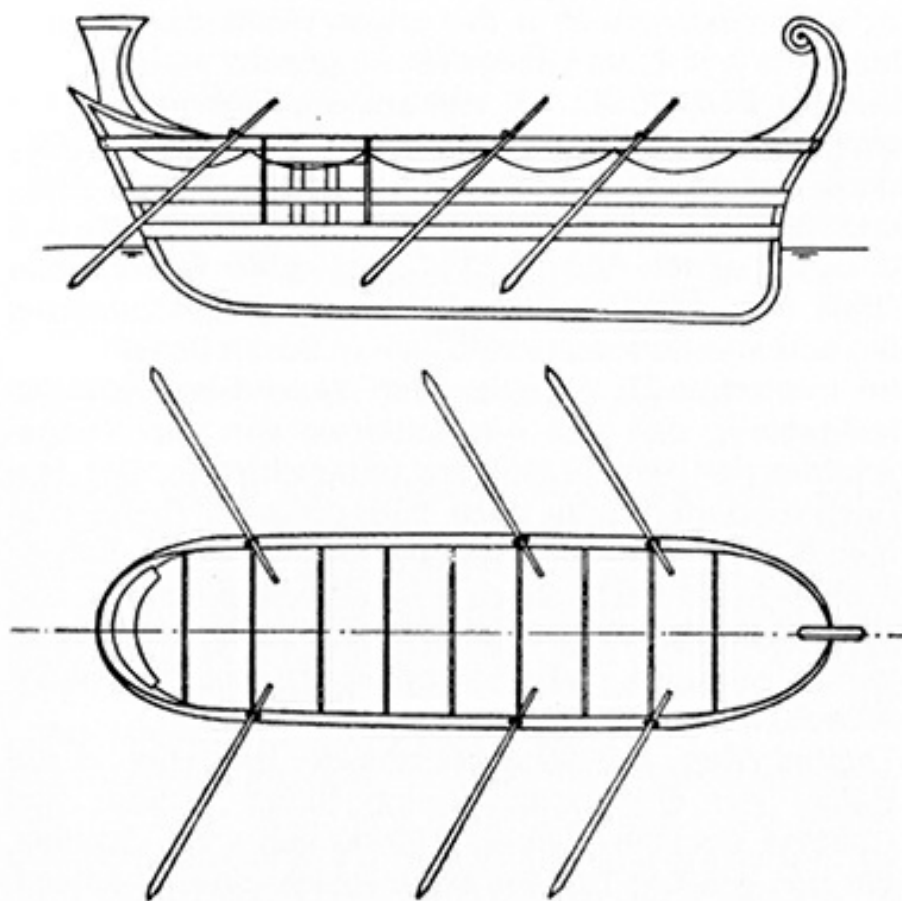

Reconstruction of a *hippagus*, third century AD. (Drawing by Andrea Salimbeti ex Viereck)

A further official mention of the *dhromon* is in Cassiodorus, *Variarum*, V, 16–18 ff. The author speaks about the new fleet of Theoderich the Great, formally a general of the Eastern Emperor Zeno, built in a hurry and assembled in Ravenna. Theoderich wrote a letter to Abundantius, a Praetorian praefect, about the construction of the fleet:

By divine inspiration we have determined to raise a navy which may both ensure the arrival of the cargoes of public corn and may, if need be, combat the ships of an enemy. For, that Italy, a country abounding in timber, should not have a navy of her own has often stricken us with regret. Let your Greatness therefore give directions for the construction of 1,000 dromones ... We praise you for your prompt fulfilment of the orders ... You have built a fleet almost as quickly as ordinary men would sail one. The model of the triremes, revealing the number of the rowers but concealing their faces ... So too the sail, that flying sheet which wafts idle men to their destination quicker than swiftest birds can fly ... Let all the fleet be assembled at Ravenna on the next Ides of June. Let our



own Padus send his home-born navy to the sea, his river-nurtured first to battle with the winds of Ocean ... The Count of the Patrimony is courteously requested to see if there is any timber suitable for the purposes of the navy, growing in the royal estates along the banks of the Po.



The ships of Aeneas as late Roman *liburnae*. (Codex Vergilius Vaticanus, Biblioteca Apostolica Vaticana, Vat.Lat.3225, f.43r, c.370–400 AD, author's collection)

According to Cassiodorus, the fleet was composed of the *dhromones* (*biremes*) and of local river boats. The author also mentions the wood that should have been employed for the building of these *dhromones*: ‘Wherever cypresses and pines are found near to the sea-shore, let them be bought at a suitable price’. It is obvious that these ships were not as large as those of the Imperial fleet of Constantinople, and that these kinds of *dhromones* would not be those which would have formed the core of the Eastern Roman fleets until the thirteenth century.



The *liburna invincibilis*, a 15th-century copy from a fifth-century AD codex of *De Re Militari*. This picture of a late Roman *liburna* in the *Notitia Dignitatum* manuscript in the Bodleian Library, Oxford, represents the decoration and armament of a fifth-century warship used in the desperate wars against Barbarian raiders. It shows a bronze *rostrum* and a mast in multicoloured steps surmounted by the Christian symbol, as well as *catafractae* along the sides. (Bodleian Library, Oxford, courtesy of the Library)

The Imperial *dhromon* of the mid-sixth century was a fully decked galley with a crew of 50 oarsmen. The name *dhromon*, Procopius specifies, was given to the ships because they were able to attain a great speed, and it was therefore this greater speed which differentiated the *dhromon* from the old *liburna*, although the *dhromon* was effectively a variant of the *liburna*. This new kind of *liburna* formed the core of the new reformed Roman navy. The *dhromones* of the Emperor Justinian are described (Procopius, DBV, 1,11) in his analytical account of the expedition against the Vandals as single-banked ships covered by decks, in order that the men rowing them might if possible not be exposed to the bolts of the enemy. The *dhromones* had lateen sails rather than the square sails favoured for the *liburna*. A spur, placed above the waterline, replaced the old waterline ram of the ancient Roman warships, still in use in some *liburna*. The illustration of ships in the Vergilius Romanus manuscript is surely one of the earlier known depictions of the spurs on the new type of war galley. <sup>2</sup>

<sup>2</sup>See MAA 451 *Imperial Roman Naval Forces 31 BC–AD 500*, p. 41.



Battle between Greeks and Trojans, folio of the *Ilias Picta* or *Ilias Ambrosiana*, 5th–6th century AD. In the scene, representing the siege of the Greek camp by the Trojans, the Byzantine artist has represented the Greek warships like two Roman *dhromones* of his age. Note the single-masted lateen-rigged crafts, the stern post curved inwards and the straight steeply raked stern post. (Ambrosian Library of Milan, author's collection)

## The *navis lusoria*

The *navis lusoria* was a small, rowed ship quite commonly mentioned in Late Roman sources, especially by Ammian Marcellinus (*Res Gestae*, XVII, 33 and XVIII,2,17). According to him, the Emperor Julianus attacked the Germans within their territory by night with such boats:

And having been brought together when night was well advanced, all were embarked whom 40 scouting boats [*lusoriae naves* – as many as were available at the time] would hold, and ordered to go downstream so quietly that they were even to keep their oars lifted for fear that the sound of the waters might arouse the savages; and while the enemy were watching our campfires, the soldiers were ordered with nimbleness of mind and body to force the opposite bank.

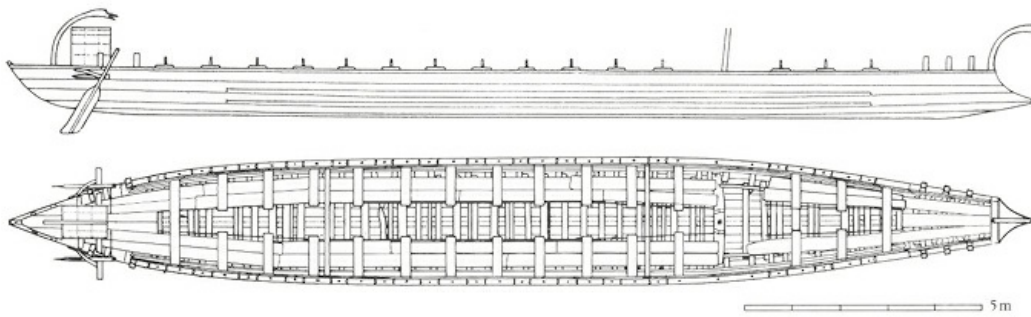

Reconstruction of the Mainz type A boat, *navis lusoria*. All the Mainz type A craft had length-to-planking thickness coefficient values of over 10.0, which is higher than that of contemporary Mediterranean craft. Moreover, there was an explicit lack of mortise-and-tenon joints in the building of these ships. Longitudinal and transverse support timbers followed those of the indigenous North Sea vessels and river craft, such as the New Guy's House Boats. (Drawing by Andrea Salimbeti ex Höckmann)

These ships were mainly used for patrolling duties, but also for swift attacks. Again, Ammianus says of Julian's operations on the Rhine:

On learning this from a sure source, Caesar at the first quiet of nightfall embarked 800 soldiers on small, swift boats (*navigii modices et veloces*), so that they might go up the Rhine for a distance of 20 stadia, disembark, and with fire and sword lay waste whatever they could find.

These *naves lusoriae* were probably influenced in their development by the large canoes and boats used by the Germans.

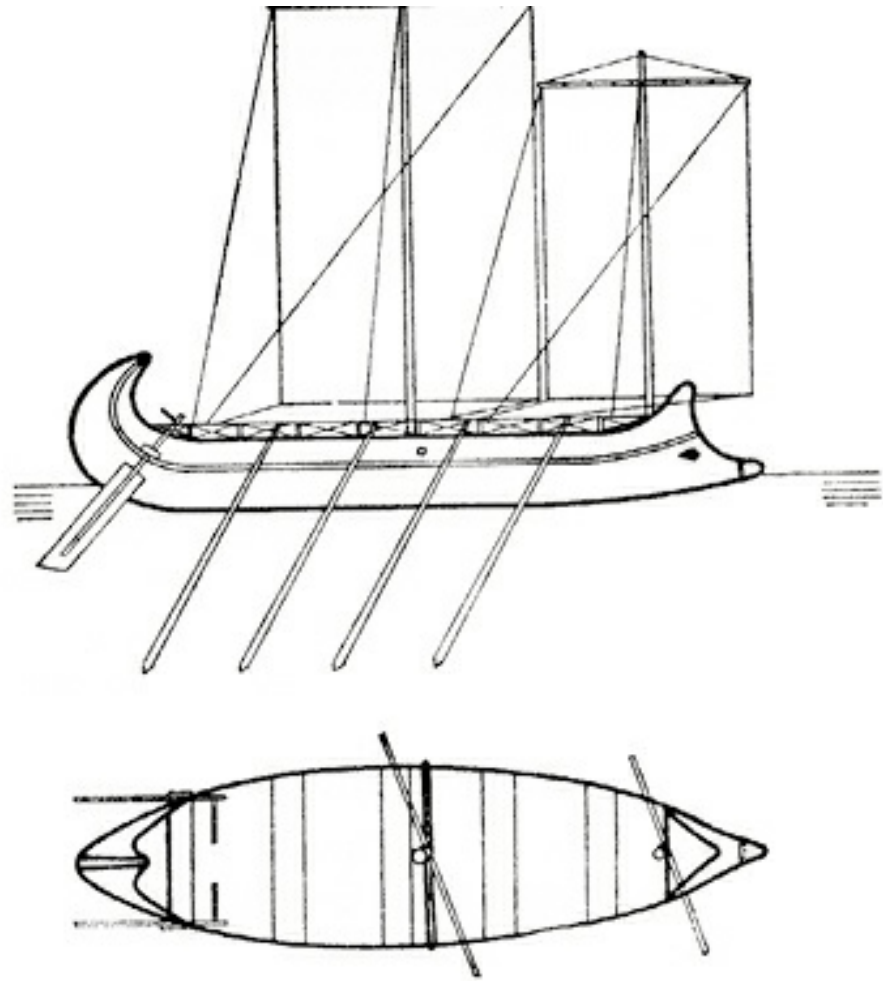

Reconstruction of a *navis lusoria*, fourth century AD. (Drawing by Andrea Salimbeti ex Viereck)

Archaeological evidence from Mainz and Oberstimm, supplemented by iconographic evidence, provides a good deal of information about Late Roman river ships. In Germany the remains of five

vessels have been found, lying on what would have been the foreshore of the Rhine in front of Mogontiacum (Mainz). The craft had been abandoned and partially dismantled by the Romans. Perhaps this occurred in a breaker's yard, at the time of the general abandonment of Mogontiacum before the arrival of the Germans in 406. According to Morrison, the ships were not part of the *Classis Germanica*, which was stationed farther south at Colonia Agrippina, but were attached to the legions in Mogontiacum.

All but one of the ships had the same structure: a narrow, open hull designed to be propelled by both oars and sails. Thanks to this find, archaeologists were able to understand how a *navis lusoria* of the fourth century was made. The image restituted from the archaeology fits well with the iconography of this age, so there is no doubt that the ships found were real *naves lusoriae*. The best preserved craft was the Vessel 9 (type A), which was 21m long and 2.7m wide across the beam. The stern of the ships was conventional, but the bow did not have a stem: instead, the sides were connected by a transverse panel that rakes aft. From the side it gave the appearance of a ram, but in reality it was a cutwater. The internal trunk fastened into the bottom of the hull of course reduced the storage capacity of the ship, and it was probably a structural feature design to increase the longitudinal stiffness of the long and narrow hull.

The vessels were precisely dated with dendrochronology to about 375–376. It seems that Vessel 1 had been repaired twice, in 385 and 394. Similar boats, found in Oberstimm, would also have had the same function, although they belonged to a previous period and were linked with the defensive system of the lower Danube.



Embarking on a *navis lusoria*, fourth century AD. (Reconstruction by the Museum für antike Schifffahrt in Mainz, Mainz, photo courtesy of the museum)

## Other ships

The Imperial fleets were not composed exclusively of warships. Large fleets consisting only of warships were not necessary as there was not a need to fight full-scale naval wars, at least not until the danger posed by the Vandals. In the late Empire various kind of ships were used in addition to the actual warships. Zosimus records that, preparing his war against Licinius, Constantine ordered the construction of 200 *triakonteres* and more than 2,000 transport ships. The shape of these transport ships is clearly visible on the African mosaics and those of Piazza Armerina. The *hyppagus*, the ship dedicated to the transport of the horses, is particularly well represented. *Camara* and *oraria navis* were also used for troop transport.

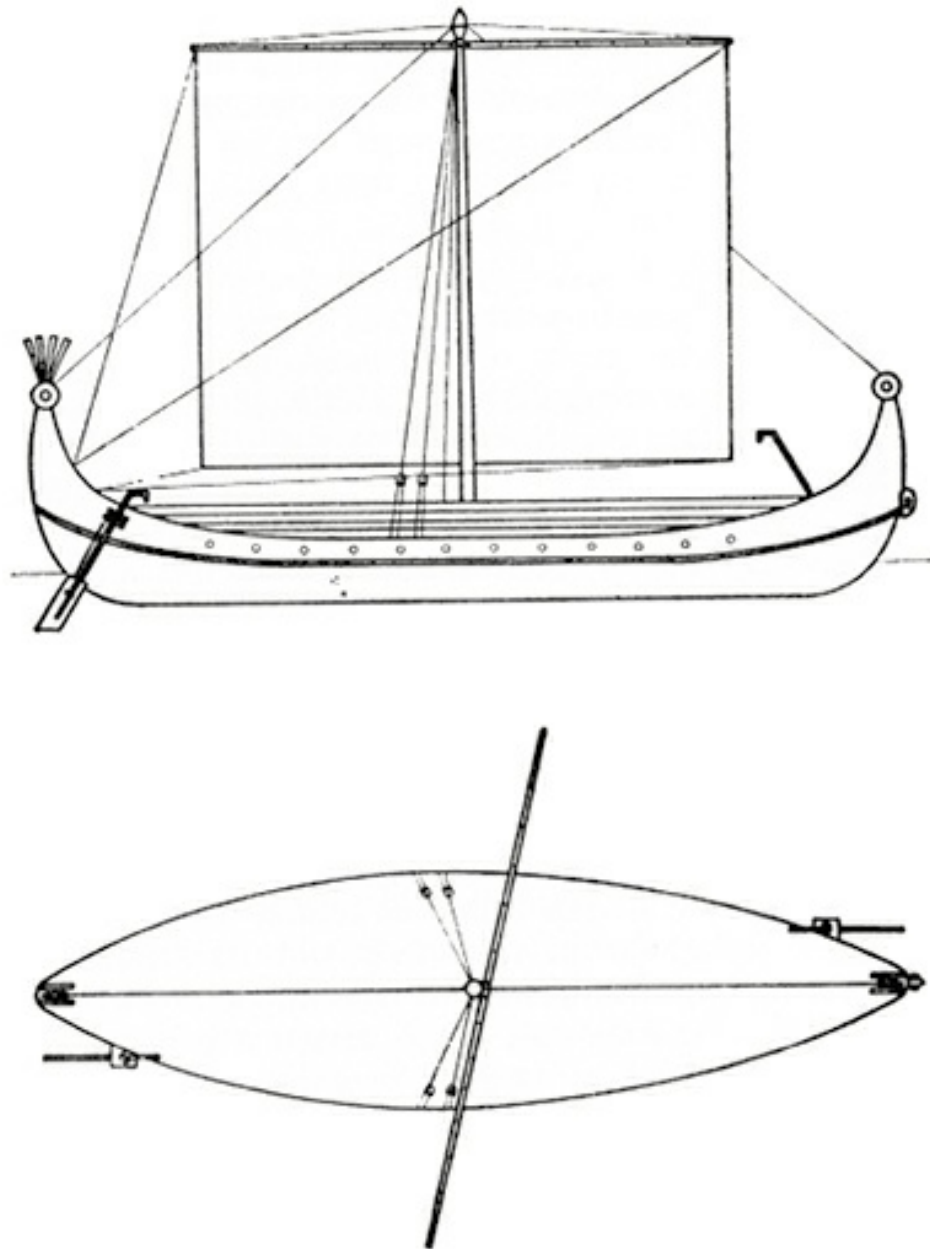

Reconstruction of a *camara*, fourth century AD. (Drawing by Andrea Salimbeti ex Viereck)

The fourth-century river fleets were fitted with two new kinds of ship: the *navis iudiciaria* and the *navis agrariensis*. According to the sources, the *Classis Moesica* in 412 was composed of 100 *naves lusoriae*, 10 *naves agrarienses* and four *naves iudiciariae*. The *Classis Scytica* had 125 *naves lusoriae*, 12 *naves agrarienses* and 10 *naves iudiciariae*. We do not know a lot about these last two kinds of ship. The first craft was probably just a light river patrol ship, and the second one was destined to transport some important functionary. According to Olaf Höckmann, one of the Mainz ships was a vessel for the transport of a high dignitary (*navis iudiciaria*). This second type, Vessel 3 (type B) was beamier, approximately 17m long and 3.5m wide, and conceived as a transport vessel

as it was fitted with a cabin for a passenger (*navis cubiculata*, i.e. fitted with a cabin, *cubiculum*).

However, according to Jeffrey Glenn Royal, this ship was more than simply a transport vessel for moving equipment, troops and possibly horses. One thesis does not exclude the other. Royal's hypothesis was based on the assumption that designating this craft a transport calls into question its reconstruction with extensive decking and a structure amidships, as a transport vessel would likely have had only a small deck, leaving a large open area for carrying cargo. Moreover, according to Royal there was not compelling archaeological evidence for this vessel having been decked.

What we do know about this ship is that it was not fitted with conventional thwarts for oarsmen. Its state of preservation is substantially poor except for the stern, of which several frames are preserved, and which extends above the gunwale to become bitts, maybe for belaying running rigging. Steering was by quarter rudders mounted in a complex protective structure attached to a throughbeam.

Beside these ships, we also have mention in the sources of the *naves speculatoriae* or *catascopii*. However, this kind of ship (known by different names as *catascopus*, *catascopium*, or *catascopiscus*) was not a specific design of ship, but an appellative that could be employed for all the ships, and corresponded to a certain function. The *speculatoria* was just an exploratory ship. Its function was to watch the enemy's forces and their movements, and sometimes to act as an auxiliary ship. In this category we may also include the *naves pictae* of the *Classis Britannica*, which were painted blue for this purpose. These ships were however heavy *liburnae* and not small craft.

Smaller boats than warships were employed in military operations. When involved in major campaigns, the Roman fleets needed a logistical capacity to transport food, supplies and military personnel, both on sea and rivers. Priscus (*Works*, IX,4) refers to the 300 ships requisitioned in 362 AD as suggesting the hypothesis that private vessels were sometimes pressed into service.

The shape of the boat built by the *faber navalis* Longidienus in Ravenna's canals of the first century AD <sup>3</sup> can still be seen in the fourth century in the mosaics of Piazza Armerina, Susa and Althinburus in Tunisia. The latter also notes the names of such ships: *cidarum*, *placidia*, *vegeia*. The Cervia boat, dated to the fourth century and 12m long with a width of 3.5m, well represents one of these boats.

<sup>3</sup>MAA 451, p. 39

Maurus Servius Onoratus, in his *commentarii* to the *Georgics* of Vergilius (*Ad Georgicas* I,262), remembers river ships (*navicula fluvialites*) that the Lintres used in North Italy (Venetiae) for commerce and hunting. They were *monoxyla* boats, and could have also been used by soldiers.

## Structure and construction

The Romans took great care in shipbuilding. In his chapter dedicated to naval warfare, Flavius Renatus Vegetius (IV,34,1) says that the material for building a ship should be sought with great accuracy, in the same way as the material for building a house, 'because a defective ship is much more dangerous than a defective house'. Vegetius (V,4) also gives us useful information about the material employed for the building of the *liburnae*: cypress, larch, fir or pine wood, and copper nails instead of iron, because 'the iron nails, exposed to warmth or damp, are quickly corroded by the rust, while those of copper preserve their original consistency also among the waves'.



Building the *naves lusoriae*, fourth century AD. (Reconstruction by the Museum für antike Schifffahrt in Mainz, Mainz, photo courtesy of the museum)

Without clear remains of warships, there is little that can be asserted with absolute certainty about their construction. However, it may be assumed with some confidence that elements of construction found in merchantmen, such as plank fastenings, internal support and order of construction, were paralleled in warships.



*Naves lusoriae*, fourth century AD. Roman military craft operating on rivers required two types of propulsion in order to respond swiftly to the need to travel upstream or downstream on short notice. Both the Oberstimm and Mainz crafts were outfitted for squared sails and oars, and their high length-to-beam coefficients made possible a greater speed under either mode. Their shallow draughts allowed these ships to penetrate the shallow waters of the Rhine and its tributaries.

(Reconstruction by the Museum für antike Schifffahrt in Mainz, Mainz, photo courtesy of the museum)

From the third century, Roman ship and boat construction techniques – especially for military use – were transformed, the product of cultural exchange with other shipbuilding peoples. At the end of this period, shipbuilders no longer used the traditional shell-first hull construction and had adopted the new method of building the hull's frames first, which were covered by planks only at the end.

The new system brought a decrease in the use of mortise-and-tenon joints, and generally lighter hulls and thinner planking for warships. Decreasing the weight of the hull would have been most advantageous to warships when rowed, for they could be rowed at greater speeds with the same number of oarsmen or be rowed for longer periods at given speeds. More efficient use of the wind when under sail was also a potential advantage of lighter warships. Furthermore, the time and expense of repairs would be drastically reduced, time often being a crucial factor during war.

However, apart from this structural evolution, which was slow, another important development in nautical technology was the adoption of the Latin sail (which in later centuries became the 'lateen' sail, used worldwide). Roman warships had unquestionably utilized both sails and oar propulsion. A square sail with brails set on a single yard was the predominant configuration observed in iconography until the fourth century, and the squared sails of the Roman ships were flanked by the spritsail. The Latin sail was the result of the need to make better use of winds other than stern winds.





Low Ham mosaic detail, representing the fleet of Aeneias. (*In situ*, Low Ham Villa, author's photo, courtesy of the museum)

The Latin sail was introduced during the third century, influenced by the Levantine world. It is clearly visible on a squadron of merchant ships arriving in Ostia harbour in a third-century relief. By the fifth century the majority of the Imperial *dhromones* were fitted with them. But the square sail never disappeared completely from the Roman ships, and the process of adopting the Latin sail was slow. The process of the disappearance of the spur began in a parallel way, either in the bronze full form of antiquity or in the shape of a simple cutwater.



Low Ham mosaic, detail of the first ship. (*In situ*, Low Ham Villa, author's photo, courtesy of the museum)



Low Ham mosaic, detail of the second and third ship. Iconographic evidence also allows many insights into the types of steering structures on warships. As with merchant ships, warships appear also to use a system of two quarter rudders for steering, often visible. However, sometimes there is a lack of mounting assemblies in warship illustrations, as in the ships depicted in the mosaic. Since these warships were undoubtedly as large as many merchantmen, they must always have required similarly large quarter rudders. It is possible therefore that they utilized a different method of securing quarter rudders in place, perhaps a beam at deck level that is not represented in the more sketched depictions. (In situ, Low Ham Villa, author's photo, courtesy of the museum)



Fragments of one of the two *naves lusoriae* found in Mainz, fourth century AD. Type A Mainz and the Oberstimm craft lacked the flat planking runs characteristic of the oared ships, but their high length-to-beam coefficients compensated for this by providing a long and slight curvature along the plan view. The curvature of the hull under this aspect also provided increased beam at midships for a greater stability under sail. All the evidence indicates that these warships used a pair of quarter rudders attached to the single transverse timber without resorting to the use of elaborate mounting assemblies. (Museum für antike Schifffahrt in Mainz, Mainz, photo courtesy of the museum)

The structure of river warships is clearly evident (at least for the fourth century) in the hulls of the Mainz and Oberstimm ships. Their construction was a little different from seafaring warships. Some trends paralleled those in the construction of Mediterranean merchant vessels, including the lack of mortise-and-tenon joints, the thinning of hull planking, and possibly some frames preceding strakes in

the construction sequence. However, the fourth-century Mainz vessels had box-like hull sections and thinner hull planking similar to indigenous-built seagoing vessels of Britannia. This suggests the involvement of local Celtico-German boatbuilders in their construction, or perhaps, as suggested by Morrison, that Roman builders had adopted local methods. By this time, military river craft were using central timbers more analogous to a thick keelplank than a true keel, while frames were becoming larger and spaced farther apart. Frames and futtocks were sometimes scarfed to another, like in those seen on the Mainz (Type B) Vessel 3.



Details of sail and mast of a Roman ship, from a fourth century mosaic. (Piazza Armerina, Sicily, author's collection)

For small boats we have precise indications from the Cervia shipwreck. The hull of this ship, 12.5m long and 3.5m wide, with a height above the water of 2.2m, was made of oak – both planking and frames. The planking was ‘sewn’ together using rope, which passed through oblique holes through the thickness of each plank, to avoid the rope directly contacting the water or possibly scraping against sand or gravel when landing. The planks were bent and joined side by side before being bound together. Holes were made through a gimlet and the remaining chips cleaned by a chisel. Then bundles of straw soaked in hot pitch were placed on the edge of the joints and ligatures. Finally, ligatures were made across the holes by combining the planks diagonally. Small wooden wedges closed the remaining holes. After the shell was finished, the stems were fixed in place with flexible shoots of wood, and, on their bottom, grooves were arranged to make way for ligatures. Once the hull was finished, pitch was copiously applied externally and internally. The ligature should be constantly kept under control, given the type of stitching.

This old system had been described by Homer and was therefore employed in the Greek Bronze Age. At the time of the Cervia ship, it was probably only used for the building of small trading boats and not for larger ships. This depended also on the conditions of navigation inside the channels and the lagoons in the region of Ravenna, as remembered by Cassiodorus (*Variae*, XII, 4):

They were kept still by ropes [*carinae*], but they move drawn by cables [*rudentes*]; the course of things is changed, and men help their ships on with their own feet. Without effort, they pull their carriers and, instead of the risks of sailing, the ships employ the more fortunate footsteps of the crew.

## Armament, equipment and decoration

Weapons used on board during naval combat included the double axe, as explained by Vegetius (IV, 46), which was a large, pointed iron weapon with two cutting edges sharpened on both sides. Employed in battle by the most expert sailors or soldiers, it could cut the cables on the sides of the rudder to make the enemy ship ungovernable. In addition the sailors used various kind of scythed weapons to cut ropes and sails, and of course missile weapons of all sorts.

*Catapultae*, *skorpions*, *ballistae* and, from the fourth century, *onagers* were the most common throwing weapons that could be found on the deck of a ship, or sometimes mounted on wooden towers with which the larger ships were often fitted.

The general tactical trend to avoid ramming attacks and instead fire missiles to burn the enemy's ships brought the development of terrible sea weapons. Marine fire began to appear during the early sixth century, when the fleet of Marinus destroyed that of the usurper Vitalianus with a mixture of inflammable liquid – forerunner of the Greek fire of the following centuries. The key ingredient in almost all the formulas for 'Greek fire' since the Hellenistic Age was what the ancients referred to as naphtha or crude oil, which, throughout the oil-rich areas of the Near East, could be scooped up at dozens of points where it seeped out of the ground. Although it was inflammable enough in its simple state, the usual practice was to lace it with sulphur, pitch or quicklime.

The tactic of ramming was never abandoned, but many illustrations of warships show them not fitted with rams but simply with a cutwater, visible also on merchant ships. So, as suggested by Royal, the presence of the ram at the lower portion of the stem cannot always be considered a characteristic component of warships; while it is likely that some of the projections in iconography indeed represent rams, like in the ships of Vergilius Romanus or in the mosaic of Cirta, there is evidence that suggests the projections cannot necessarily be equated with rams, like in the ships of Low Ham mosaic. They are undoubtedly warships, but their structure is similar to merchant vessels shown with concave bows and ram-like projections, like the ship found in Madrague de Giens.

The anchors of small ships, like the two anchors found on the Cervia shipwreck, were iron with a wooden stump. This type is little documented for the late Roman Age, where the dominant typology, for both small and larger ships, was the wooden one with a plumb stump and ferrule. The arms of the anchor of Cervia were attached to the shaft by forging, i.e. heating the parts until they were red-hot, and hammering them together. The Cervia ship also had a plumb line, a very modern technique for the time.

While the names of pre-Christian Imperial ships were linked to the gods or the great rivers of the Empire (like *Tigris*, *Euphrates*, *Nylus*), the Christian Empire preferred names like *Concordia*, *Lustitia*, *Libertas*, *Pax*, *Pietas*, and the like.

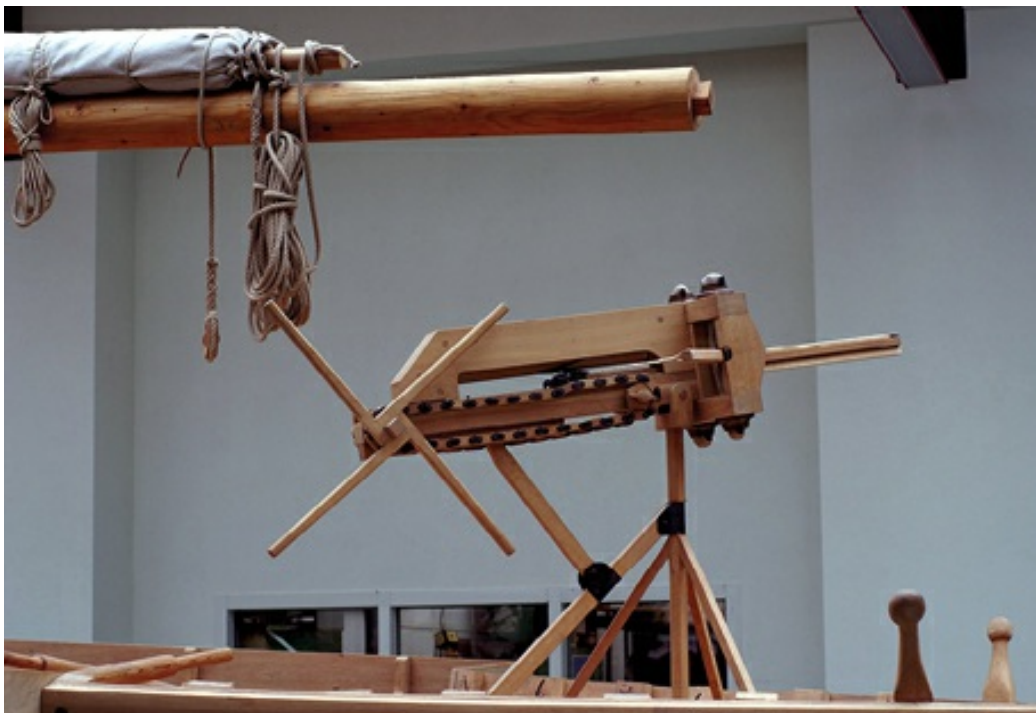

Catapult mounted on a warship, fourth century AD. (Reconstruction by the Museum für antike Schifffahrt in Mainz, Mainz, photo courtesy of the museum)

Sails were decorated, and it is possible to see, in a merchant ship moving in the harbour of Ostia in about 200, 'the She-Wolf feeding Romulus' embroidered on the big square sail. Such decoration was also applied to the warships. Interestingly, the fleet of Belisarius, sailing towards Africa against the Vandals, seems to have had a signal of identification for the commander's ship, which was inherited by later Italian sailors and it is still used today by sailing boats of the Adriatic. According to Procopius (BV,I,13), Belisarius:

... painted red the most possible of the sails of the upper corner of the three ships on which he stayed, for about one third of their length, and erected upright poles on each prow, and hung lights from them, so that both by day and by night the ships of the commander might be distinguishable, then ordered all the helmsmen to follow these ships ...

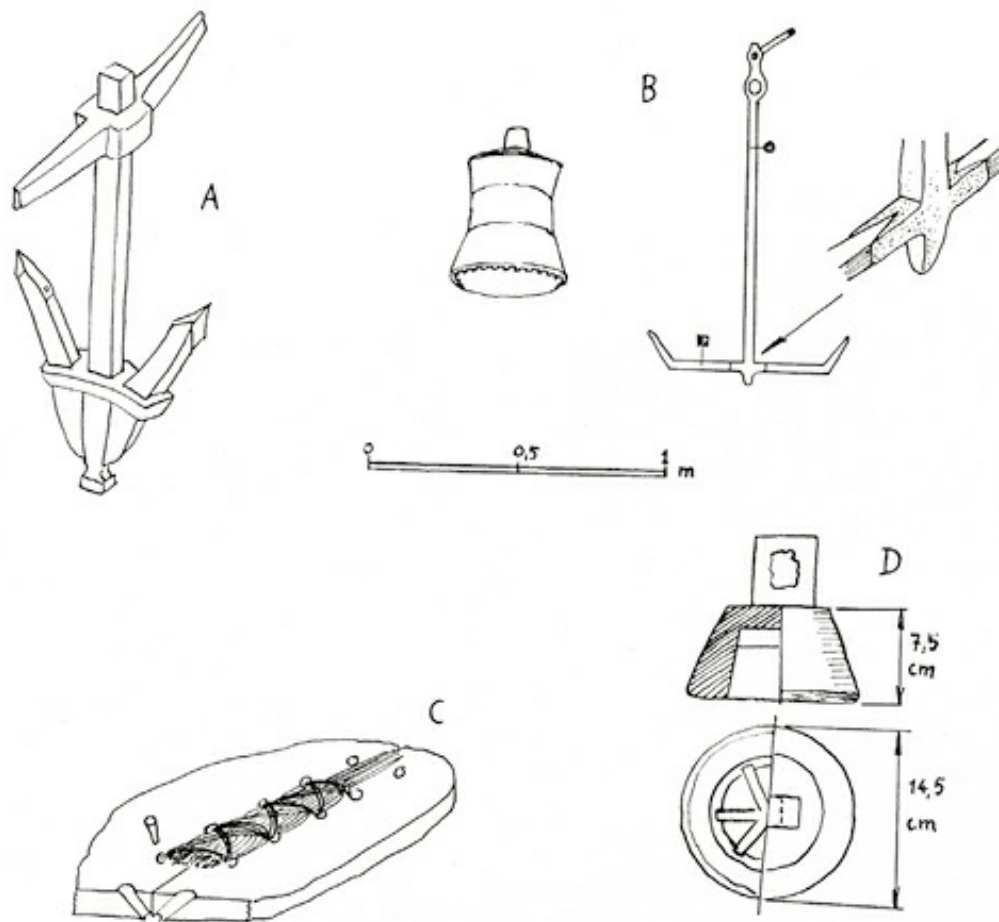

Elements of late antique ships: A) wooden anchor with lead log and ferrule; B) iron anchor and copper pitcher from the Cervia boat; C) sewings of the planks of the Cervia boat, fourth century AD; D) lead sounding of the Cervia boat. (Drawing by Andrea Salimbeti ex Bonino)

A famous passage by Vegetius is of extraordinary importance for our knowledge of how the Romans painted their ships. It says that the sailors and the troops embarked on the *naves exploratoriae* or *pictae* (i.e. the painted ships with exploratory duties) wore a blue-green tunic (*venetus*), at least during his lifetime (Vegetius, IV, 37). The reason the sailors and the embarked troops wore such a *veneta vestis* was that this colour is *marinis fluctibus similis* i.e. ‘similar to the sea waves’. Vegetius states that this colour was used not only for the tunics, but also for the sails of these ships to match the colour of the sea and escape detection more easily in day and in night. Besides this passage, iconography shows a great variety of colour and decoration on the Roman ships of this period.

Standards were often placed in the sterns (but in the case of the naval battle of Cirta, on the stem) of riverine or seagoing warships to designate the vessel of the commander and/or unit. By *circa* 250–450, standards are rare on depictions of river- or seagoing warships, although historical references suggest that they were present at this time. Valentinian, in crossing the Rhine to meet Macrianus in 374, boarded river boats staffed with officers and decorated with standards (Amm. Marc. XXX, 3.4–5).

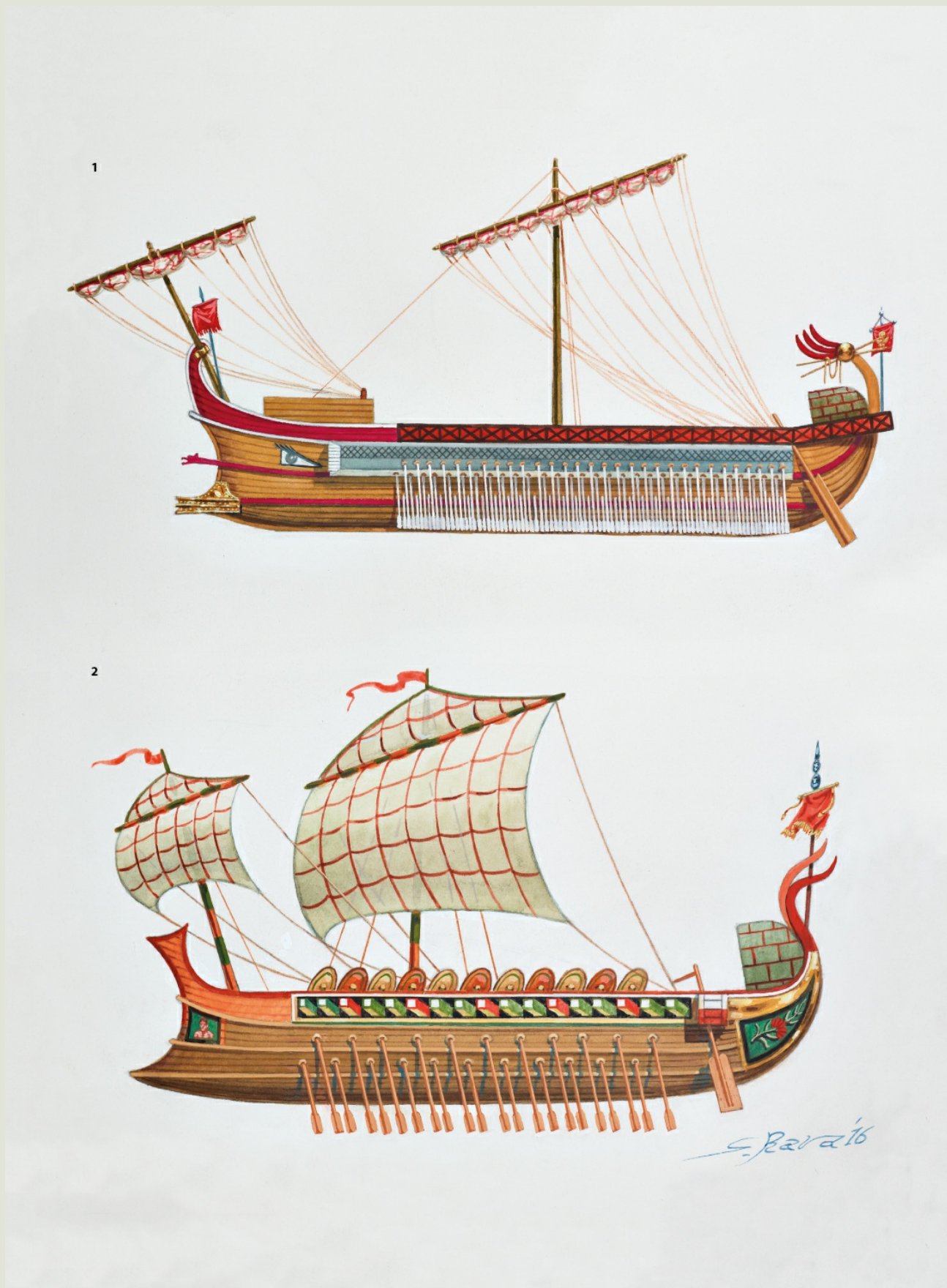

The *Radians* is one of the few *triremes* mentioned for the British fleet at the turn of the second and third century. The reconstructed *triremis* is *cataphracta*, i.e. decked, and with the oars placed within the span of the hull. As in the previous models, a long box projection running from bow to just short of the steering oars was still used, although it did not accommodate more oarsmen. This mechanism is also visible on the Cirta mosaic.

## 2: RIVER LIBURNICA BIREMIS, CLASSIS ALEXANDRINA, 3RD–4TH CENTURY AD

The model of this ship of the *Classis Alexandrina* is taken from the famous mosaic of Odysseus from Dougga. Note the small beak, shaped like an extension of the keel; above this, a divine image, probably identified the name of the ship; the *catafractae* covering the rowlocks; the steering oar; the cabin-like superstructure ahead of the upswept stern decoration; and the general impression of decorative painting. Note also the *aurica* foresail rigged in addition to the squared mainsail, and the spars painted in orange and green.



1

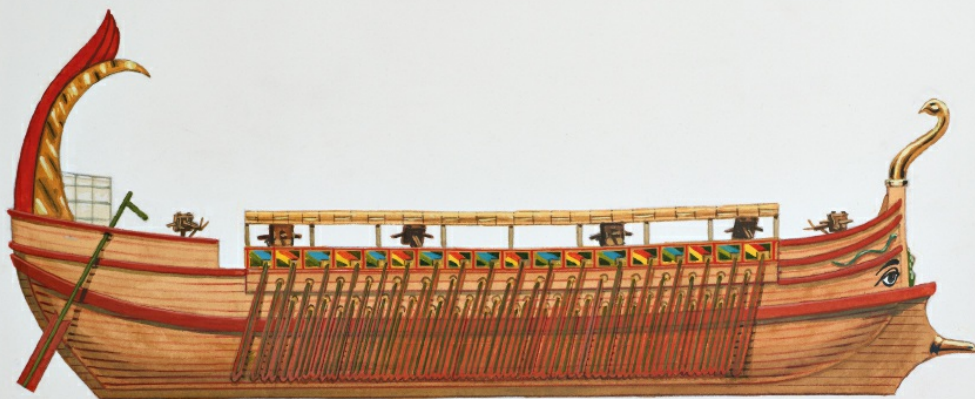

2

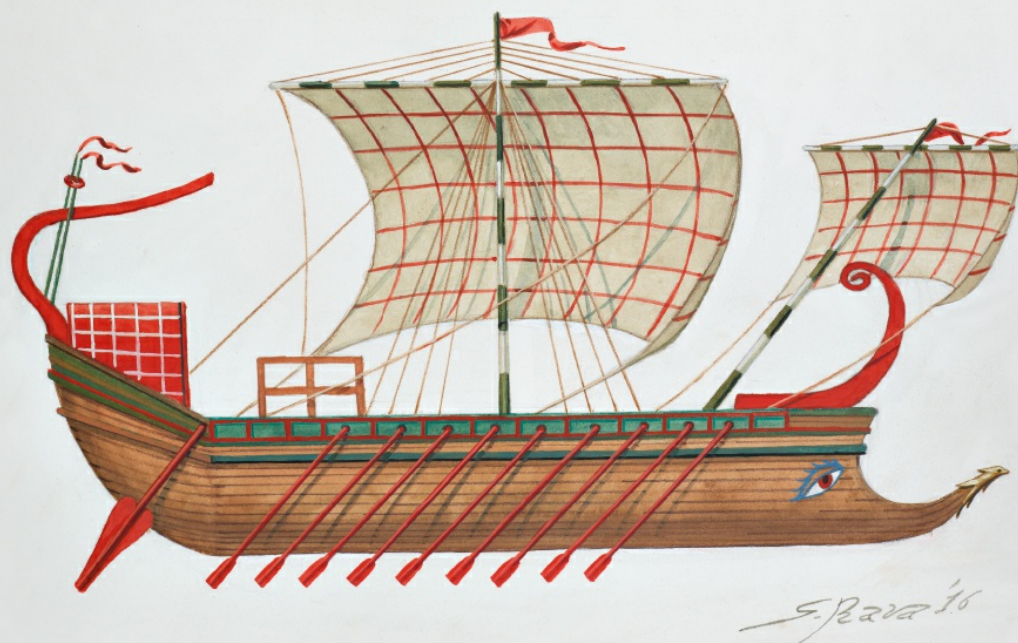

1: The *quadriremis* is reconstructed here according to the one represented on the medallions of Gordianus. Generally the *quadriremes* continued to have two banks of oars per side, with two men per oar, with a possible total number of 88 oars on each side, rowed by 176 men. Note that, as in the medallion, the stem and the stern figures are looking in the same direction, a peculiarity of the third century visible also on bronze models of *liburnae* from the Danube sites.

2: According to Aelian (*Historia Varia*, 8,17), in the early third century a warship would be rowed by 50 oarsmen, thus

having 25 oarsmen per side, a realistic number for a single-bank vessel. In order to provide approximately one metre of space for each oarsman to row and an adequate length at the bow and stern, ships would need to have been around 28 to 32m in length. Vessels of such size are common in the archaeological record into the third century.

D **DHROMON BIREMES, 565 AD**

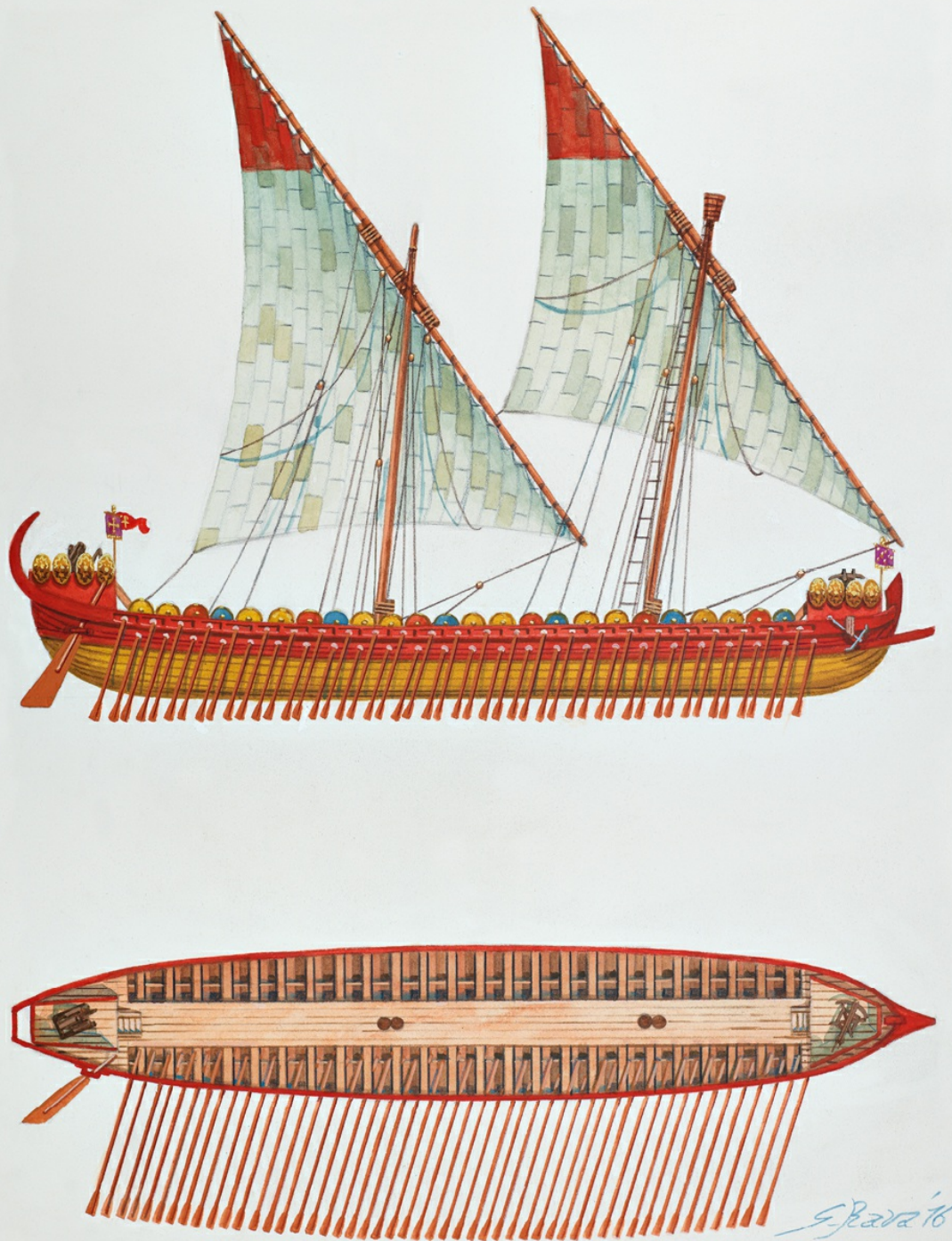

The *dhromon* was now the main battleship of the Mediterranean Sea. Procopius describes that, according to the Roman tradition, the warships had two sailing sets, the mainsail and the topsail (*Procopius*, BV, I, 17: 'And he commanded the sailors to follow along with them always and not to separate themselves far from the army, but when the wind was favouring to lower the great sails, and follow with the small sails, which they call *dolones*, and when the wind dropped altogether to keep the ships under way as well as they could by rowing'). In the age of Justinian the

Great, the *dhromon* already possessed the lateen sail, with the head of the sail painted red, a custom still employed today in Adriatic sailing boats. This warship, in the *biremis* variant, was 42m long and 6.50m wide, had two rowing orders, 25 oars for each row, two lateen sails and the ram at the height of the deck. Its height was 3m above the waterline. For fighting two castles were mounted, at the stem and at the stern. Wooden 'wings' were built on the stern to lean the long pennons when the sails were lowered. The hull was massive and the floor timbers made a fairly sharp angle with the curvature of the sides. This heavy ship was strongly armed, probably already having engines for throwing 'marine fire' or 'Greek fire' at this time.

E 1: NAVIS LUSORIA (MAINZ TYPE A), SECOND HALF OF FOURTH CENTURY AD

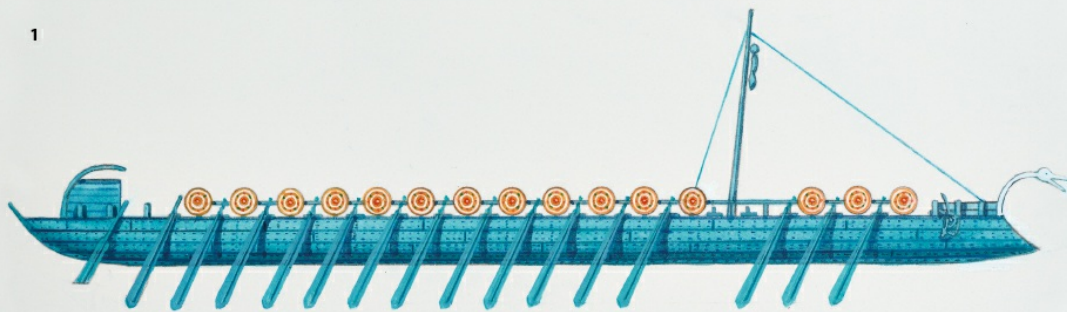

The *navis lusoria* – here reconstructed from one of the Mainz craft – was carrying a mast stepped in a heavy frame relatively far forward, and was rowed by a maximum of 15 pairs of oarsmen. Its construction was relatively heavy for an oared ship, with large, closely framed spaces, but it shows a keelplank rather than a heavy keel. An internal trunk was fastened into the bottom of the hull and ran most of the length of the vessel. The boat represents the last technological marine development of the Roman Rhine frontier defences. According to Morrison, this kind of ship was

built for obtaining speed and it was easy to row, although it was not designed to be engaged in water-borne combat. Despite this, it would have been the perfect craft for attacks on large German boats like that at Nydam. Moreover, these ships could be used for transporting small detachments of soldiers.

## **2: PROTO-DHROMON, LATE FIFTH CENTURY AD**

The *proto-dhromon* was a *monoreme* with a central mast, a single bank of 15 oars on each side, two men for each oar, a lateen sail, and a crew of six officers, 12 sailors, 30 or 40 marines and 80 rowers, for a total crew of 128–138 men. The dimensions given by Viereck are 28m length, 4.40m width and 0.90m draught. This variant of the *liburna* has a bow more lightly constructed than that of its prototype, and, without the need to be strong enough to support a working ram, the stern was slimmer and designed more for speed. The *dhromon* was a successful ship because of the combination of its higher speed, the substitution of the squared sail with the lateen sail, the covered deck (*cataphractus*) for the oarsmen banks and the rising of the spur over the waterline. The *dhromones* of this period are however smaller than those of the successive age.

# FIGHTING ON THE SEA: LATE EMPIRE ROMAN NAVAL TACTICS

According to Cassius Dio, writing in about 229, the bigger battleships towered not only above the light units, but also the rocky islands and the castles. The situation was completely different in 324. When the fleet of Licinius, composed of *triremes*, clashed with the Constantinian one, the old battleships could not withstand the tactics and the methods of fighting of the new *moneres*. Moreover, 120 *triremes* of Licinius' fleet were damaged and destroyed by a tempest, which the Christian writers could not avoid ascribing to the favour of God towards Constantine. The rest of Licinius' fleet could not stop the advance of Constantine's fleet in the direction of Byzantium.



Coin (*foliis*) of Constantine the Great. On the obverse can be read *CONSTANTINVS AVG MAX* (Constantinus Maximus Augustus), here represented with diademed head. On the reverse the inscription *LIBERTAS PVBLICA* (Public Freedom) is exemplified with a Victory standing facing, head left, on galley right, wreath in both hands held out at shoulder height. (Mint of Constantinople, 327–28 AD, with the representation of a *triakonteris*, private collection, courtesy of Forum Ancient Coins)

The victory of Constantine's fleet was mainly due to the thinner hulls of his ships. The hulls of his *triakonteres* and *pentekonteres*, which featured thinner planks with fewer, smaller, and more widely spaced (if any) mortise-and-tenon joints than Licinius' *triremes*, may have incurred less damage from ramming blows because the thinner strakes more easily gave way at the point of impact, since they were not integrated into surrounding strakes in the hull.

Less hull damage from the impact of ramming and possibly less water intake from the compromised areas would have surely been advantageous in the rare instances when ramming might have occurred. More significantly, these lighter warships had greater speed and manoeuvrability, when under oared propulsion, than heavier, slower vessels. This gave an advantage to lighter warships utilizing projectile weaponry, with both offensive and defensive tactics becoming more effective.

As previously mentioned, the fact that the projections represented on many warships were cutwaters and not rams also suggests this change in tactics. Oared warships with a cutwater would have had finer entries and could possibly attain higher speeds or longer rowing endurance. They would also have had a speed advantage under sail and, unlike the merchant ships, they were not burdened with the need to maximize hold space. Although these advantages would be served by cutwaters or rams alike if worn by smaller warships, cutwaters would not have permitted ramming tactics. Furthermore, building warships with cutwaters used less labour and material than those with rams. This points to the hypothesis that, at least from 250 onwards, there was a continued trend towards the use of naval projectile warfare in lieu of ramming tactics. However, it will suffice to note here that the frequency

of depictions of screens on warships increased around 250–450 AD compared to those in circa 50–250. This may represent further efforts to protect the ships from missile weaponry.



The ships of Aeneas as late Roman *triremes*. A lot of iconographic evidence for late Imperial warships appears to indicate large and highly decorated vessels, some of them depicted with Imperial standards. Note the high stern of the ships, one of the few representations of *triremes* in the late Roman period. It is likely that these structures represented the upper portions of galleys. Their particular configuration suggests that they were for the protection of individuals from the elements and from missile fire while they maintained an eye on the operations of the ship. (Codex Vergilius Vaticanus, Biblioteca Apostolica Vaticana, Vat.Lat.3225, f.58r, c. 370–400 AD, author's collection)

This is also noticeable in the representations of river warships, which saw a similar increase in the depictions of screens, and supports the idea of continued movement towards increased naval projectile warfare. It is noteworthy that depictions of transport vessels from the sixth century appear to have screens made of shields. This would be consistent with the necessity for screen protection on both sea and river warship depictions in later periods where projectile weaponry was in greater use.



# OPERATIONAL HISTORY

## The Gothic Wars, 238–271

After two centuries of easy living, carrying out peacetime manoeuvres and ferrying troops, Rome's great navy had, like so much else in the Empire, gone soft. By 230 the plague of piracy erupted again; in 238 the Goths crossed the lower Danube, raiding Moesia and Thracia and attacking and sacking the *Classis Moesica* base at Istrus. They were defeated by Gordian III.

In 251 the Gothic danger was even more dramatic: the emperor Decius was killed with his son in the battle of Abrytus, and Goths, Scythians and other barbaric peoples put together a fleet of 500 vessels (of all types) in the Euxine. Goths on the warpath were nothing new; the movement of Barbarian peoples that was to tear huge rents in the fabric of the Roman Empire was well under way in 251. What was new was to find them on the sea. They managed to get through Propontis (now the Sea of Marmara) into the Aegean Sea, and Greece and Macedonia were exposed to their naval raids. The Roman fleets caught and stopped them; the operation probably involved ships of the *Classis Moesica*, the *Classis Pontica* and the *Classis Syriaca*. This is at least the hypothesis advanced by Michael Pitassi, who was taking into account that the Moesica was patrolling the West Euxine (Black Sea), and the Pontica the South Euxine and the Propontis. The Syriaca was the main fleet and defended the Aegean Sea. The Danube fleet was probably the most involved, because of the necessity of constant patrolling and scouting of the river and its banks in search of enemy bands. This involved frequent fighting in a marshy, flat and difficult land. In any case, all the possible Roman units were involved, and the invaders paid a costly price for their maraudings.

Between 253 and 267 Goth forces were again using the waterways of the Black Sea and the Aegean Sea to get to Roman territory to raid. The Goths migrated from the Baltic to the Black Sea along Russian and Ukrainian rivers, and destroyed the Bosphorean kingdom of Tanais (modern Rostov-on-Don), which was allied to Rome. There they developed their seamanship, transforming the old river boats they used for their migration into sea boats. From their bases in Crimea, the Goths raided as far as Roman Anatolian and the Balkan coasts. An inscription remembers the pirates occupying an island of the Danube's delta, from where they could prey on the river traffic.

Roman fleets engaged and won battles off Rhodes, Crete and Cyprus. In 254 the Barbarians, using Bosphorean ships managed by locals, again raided the Anatolian coast to be defeated heavily once more. In 256 the raids were renewed again, but this time Emperor Gallienus struck back with naval and land forces, engaging the Goths with fleets on both the Rhine and Danube rivers. Five years of fierce wars were fought, and notwithstanding the quality and superiority of the Roman armies, they could not completely achieve success because of the necessity to fight on three or four fronts simultaneously against an enemy continuously growing in number and aggression.



Diagram of the elements of warships on Roman coins, third century AD. (Drawing by Andrea Salimbeti ex Royal)

1. Aphlaston elements
2. Bird
3. Artemon

4. Stern structure
5. Wale, outboard gangway
6. Quarter rudder
7. Ram
8. Oars
9. Goose head
10. Screen

In 259 the Goths attacked again from the Black Sea area. Their boats, passing across the lower Danube, sacked Moesia and Thracia once more and arrived on the Propontis. With 500 boats, and any other sort of craft that they could find, they besieged and sacked Cyzicus, which was probably the base of the *Classis Pontica*. The fleet was destroyed, or at least severely damaged to the point of being ineffective. The Goths then proceeded towards the Aegean Sea, attacking Athens, the Peloponnese and the Ionian coast, and sacked the temple of Ephesus before retreating again. In 267 the new Gothic sea incursions were defeated by Odenathus of Palmyra, but in 268 massive new raids by Heruls and Goths invested the provinces of Moesia and Thracia by sea and across the Danube. However, this time the new, re-formed *Classis Pontica*, under its brave commander Venetianus, destroyed the Barbarian fleet. Venetianus' death, however, allowed the remains of the Gothic fleet to sail towards Athens and sack it before the fleet was completely finished off in another naval battle.

In 269 the Goths launched their last offensive, attacking Thessalonica from the sea. However, in 270 the Emperor Claudius II Gothicus (269–270 AD) defeated them heavily, and the remains of the Gothic fleet, which had roamed across the Aegean to attack Rhodes, Crete and Cyprus, was intercepted by the *Classis Alexandrina* under the command of the future emperor Tenagino Probus. In a series of running and devastating naval battles, Probus, with the help of the *Classis Syriaca*, defeated and totally destroyed the Goths. The *Historia Augusta* remembers with triumphant words this great Roman success (SHA, Divus Claudius, 8):



Roman *hippagus*, from a fourth century mosaic. (Piazza Armerina, Sicily, author's collection)

They had, furthermore, two thousand ships, twice as many, that is, as the number with which all Greece and all Thessaly together once sought to conquer the cities of Asia. This number, however, was devised by the pen of a poet, while ours is found in truthful history. And so do we writers flatter Claudius! The man by whom two thousand Barbarian ships and three hundred and twenty

thousand armed men were crushed, destroyed and blotted out, and by whom a waggon-train, as great as this host of armed men could fit out and make ready, was in part consigned to the flames and in part delivered over, along with the families of all, to Roman servitude ...

## The Persian campaign of Julianus, 363

The Persian campaign of Julianus (361–363) represents the last war of expansion of the Roman Empire, in which the fleet was abundantly employed. A Roman fleet of 1,100 ships arrived and bridged the Euphrates. Julianus' fleet is compared by Ammianus (XXIII,3) to that of the mighty king Xerxes, under the command of the tribunes Constantianus and *Comes* Lucillianus; it consisted of 1,000 cargo ships (*onerariae naves*) of varied construction, and brought an abundance of supplies, weapons, and also siege-engines; there were in addition 50 warships (*bellatrices naves*) and an equal number which were needed for making bridges. During the campaign the *Comes* Lucillianus, with 1,000 light-armed troops embarked in ships, was sent, by the emperor's order, to capture the fortress of Anatha on the Euphrates. The ships, according to orders, took suitable positions and blockaded the island, while a misty night helped the Romans in their surprise attack. On this occasion, the emperor, who from an elevated point had been looking for a site for a camp, with all possible haste crossed the river, under the protection of two ships, followed by a great number of boats carrying siege-artillery. Ships were mainly used for transport of food and supplies (XXIV,2).

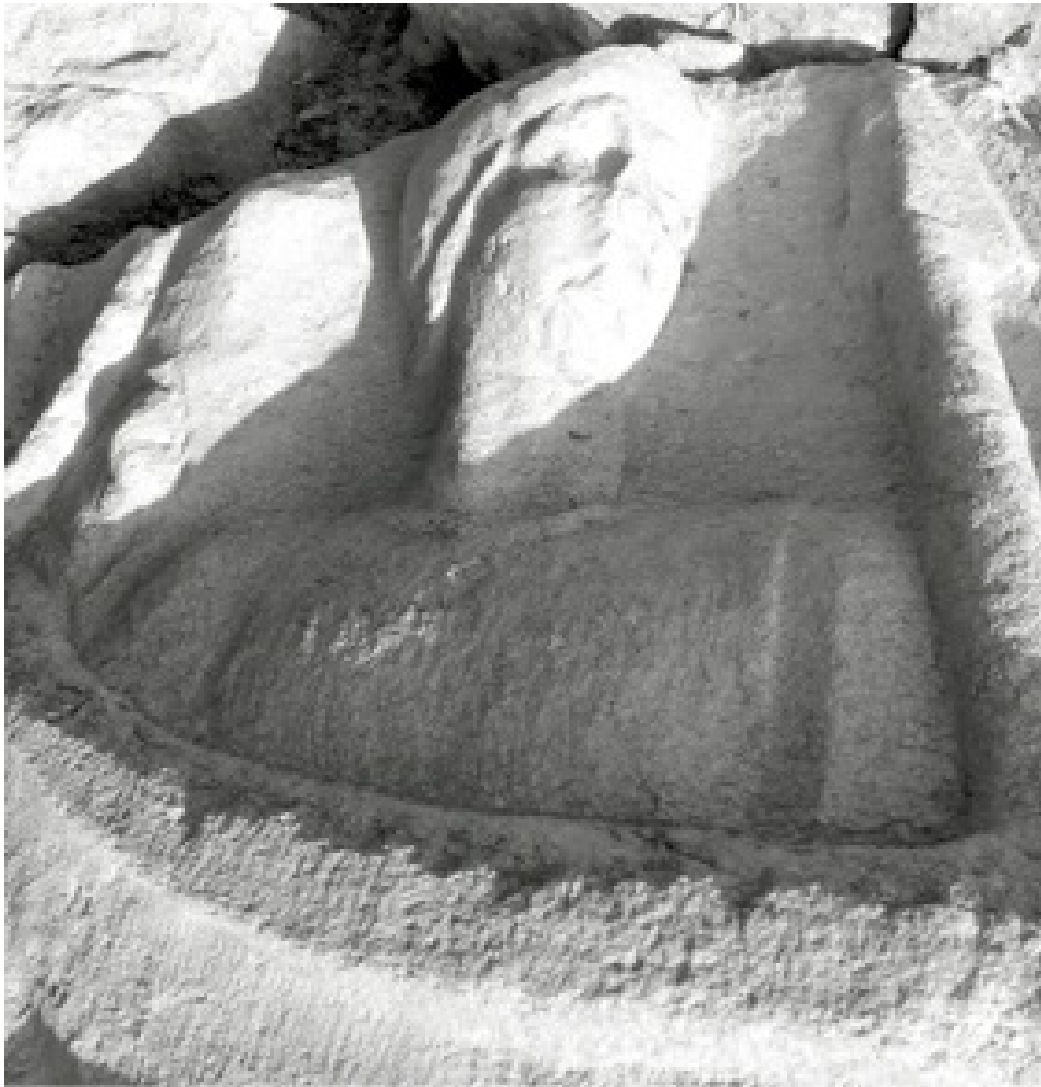

Fragment of the Theodosius Column, 400 AD. The fragment, still visible today on the external side of the Beyazit bathrooms, recorded the military operations against the Goths of Gainas in 400 AD, performed by the Roman fleet patrolling the Hellespontus, the Marmara Sea and the Bosphorus. (Istanbul, Beyazit Hamam, *in situ*, author's photo)



Fragment of the Theodosius Column, 400 AD. Here the embarked Roman soldiers are armed with muscle leather thorax and a spear. The helmet is of the usual Attic shape, but enlarged to protect the neck in a wider way. (Detail, Istanbul, Beyazit Hamam, *in situ*, author's photo)

## **The Italian reconquest wars of Justinian the Great, 531–561**

This Gothic War opened in 535 with a two-pronged amphibious assault on the outposts of the Ostrogothic kingdom. Belisarius was sent with a fleet and an army to occupy Sicily and in the following year crossed to Calabria. Justinian also sent Constantianos with a fleet to Epidaurus and then to Salona, to expel the Goths from this city. In the first major Gothic deployment of naval forces, the Ostrogoths' King Witigis sent an army by sea, supposedly with many *ploia makra* (large ships), but the Goths were heavily defeated (Anonymous addition to Marcellinus Comes, *Chronicon*, Annus 535; Procopius, *BG*, V.v.1–7, V.v.12–19, V.vii.26–37, V.viii.1–7, V.xvi.5–17). Every year Justinian sent fleets by sea.



Detail of a mosaic from Saridere, fifth century AD. In the detail a small warship is represented, with the stern identical to the prow. (Gaziantep, Zeugma Mosaic Museum, author's photo, courtesy of the museum)

In spring 539 Belisarius left 1,000 men encamped outside the city of Osimo by the shore, then sent a fleet with an army to Rimini while another advanced up the coast, and made a sweep to the west himself. The sudden appearance of the Roman fleet over the horizon precipitated a Gothic flight from Rimini back to Ravenna. With command of the Po and the Adriatic, Belisarius besieged Ravenna late in the year and Witigis was starved into submission. Belisarius entered Ravenna unopposed in May 540 and at the same time a grain fleet entered its port, Classe, the old seat of one of the Praetorian fleets, to supply the city (Anonymous addition to Marcellinus Comes, *Chronicon*, years 538–40; Procopius, *BG*, VI.xvi.18–24, VI.xvii.21, VI.xxviii.6–7, VI.xxix.31).

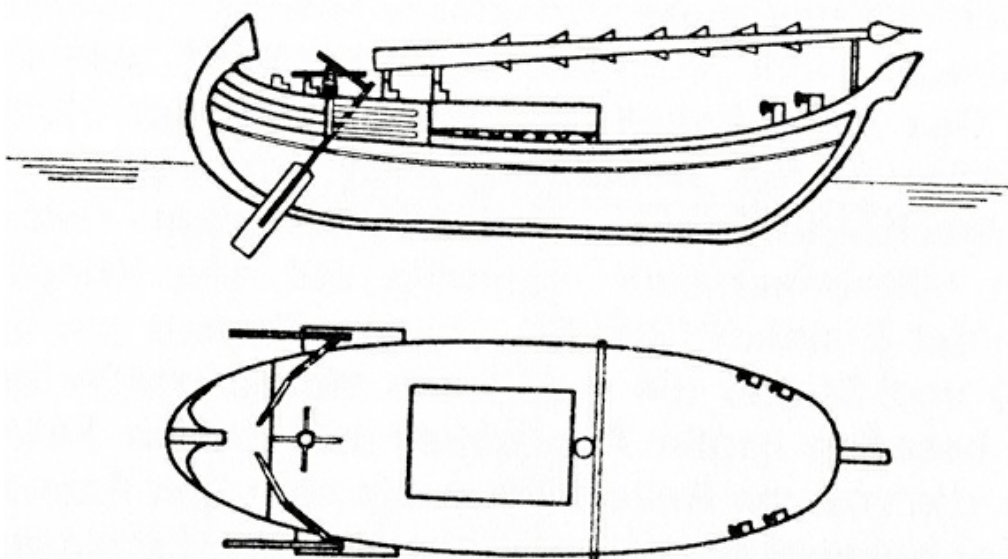

Reconstruction of a *navis oraria*, fifth century AD. (Drawing by Andrea Salimbeti ex Viereck)

After becoming the new Gothic king in 541, Totila perceived the need for naval forces to balance those of the Romans. In 542, after Totila had caused several defeats to the Romans in North Italy, Justinian sent out a fleet under the Praetorian prefect Maximinos. The *strategos* Demetrios, sent to Sicily with a new fleet, sailed to Rome instead, but was attacked by Totila and destroyed by many *dhromones* when he brought his fleet to Naples. This is a clear mention of Gothic employment of

*dhromones*, after Cassiodorus' reference to the Teoderich fleet.



Achilles and Patroklos on the ships, folio XXXVII of the *Ilias Picta* or *Ilias Ambrosiana*, 5th–6th century AD. (Ambrosian Library of Milan, author's collection)

In the autumn Maximinos was persuaded to send his fleet to Naples. Caught by a storm, it was driven ashore near the Gothic camp and mostly destroyed (anonymous addition to Marcellinus Comes, *Chronicon*, years 542–44; Procopius, *BG*, VII.vi.10–17, VII.vi.24–5).



Achaean ships, folio XXXI–XXXII of the *Ilias Picta* or *Ilias Ambrosiana*, 5th–6th century AD. The illustrations of the *Ilias Ambrosiana* are one of the early depictions of galleys with stemposts raked strongly forward and flared bows of a type that ought to have decreased water resistance and increased speed. (Ambrosian Library of Milan, author's collection)

In 545 Totila moved on Rome, which he cut off by sea by a light fleet stationed in the Aeolian and other coastal islands. A fleet sent from Sicily by Pope Vigilius to reprovision Rome was intercepted off Ostia and captured (Procopius, BG, VII.xii.1–3, VII.xiii.5–7, VII.xv.9–13, VII.xv.1, VII.xvi.16–21). Shortly afterwards Totila took the city.

In 546, after receiving reinforcements at Dyrrachion, Belisarius sailed to Rome. Outside Rome Totila bridged the Tiber to prevent boats reaching the city. At Ostia Belisarius fortified 200 *dhromones* with wooden parapets with bow-slits and made other preparations to ascend the Tiber. After failed attempts, Belisarius sailed for Sicily and then Taranto with 700 cavalry and 200 foot soldiers, but was forced by a storm to put in at Croton. It is clear from Procopius, on this occasion, that the Romans were transporting cavalry and horses around the coasts (Procopius, BG VII.xxvii.1–4, VII.xxvii.13–17, xx viii.3–7).

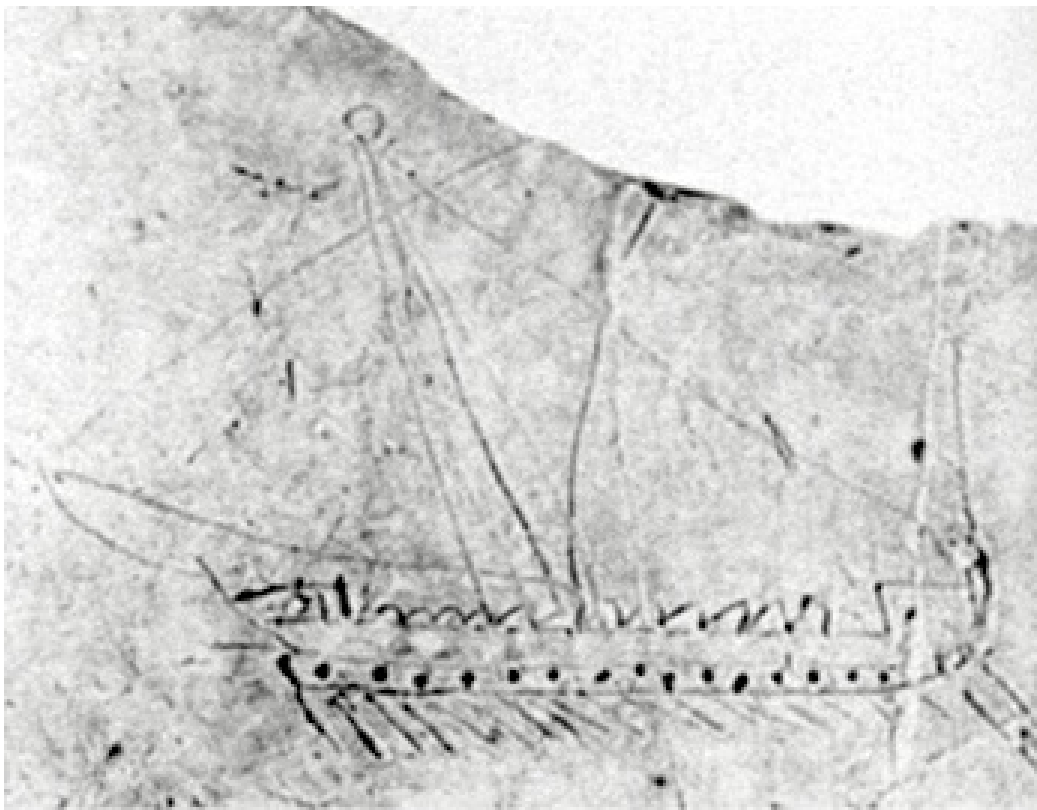

*Dhromon* with lateen sails and shield protection, sixth century AD. (Graffito from Malaga, Naval Museum Madrid, photo courtesy Domenico Carro)

In 548 Justinian sent 2,000 infantry by sea to Sicily and Belisarius at Otranto gathered a large fleet and sailed to the relief of Rossano; however, his fleet was scattered by storms and after regrouping was blocked from landing by Totila's army. Belisarius was recalled to Constantinople in 548. In the same year a Roman deserter, Indoulph, went to Dalmatia to a place called Mouikouron near Salones and then to Laureate. The general Klaudianos attacked him with a fleet of *dhromones* but was defeated, the crews abandoning their ships in the harbour. After this Indoulph returned to Italy, where Totila gave him and other commanders 47 *ploia makra* to besiege Ancona (Procopius, *History of the Wars*, VII.xxxv.1–2, VII.xxxv.23–30, VIII.xxiii.1–3). In 549 Totila readied 400 *ploia makra* as well as a fleet of large sailing ships sent from the East, which had been captured. In response to a Gothic attack on Reggio, Justinian sent a fleet and army under the *patrikios* Liberios to Sicily, later replacing him with Artabanes. Liberios sailed to Sicily and forced entry to besieged Syracuse. Artabanes' fleet, following him from Kefallenia, was scattered by storms off Calabria and driven to Malta. Totila and the Goths had meanwhile plundered Sicily for grain and treasure, and took it back to Italy on their ships (Procopius, BG VII.xxxvii.5, VII.xxxix.6–10, VII.xl.10–19).

Totila manned 300 *ploia makra* and sent them to Corfu. They reached and plundered it and the opposite mainland, and then sailed along the coast capturing many Roman ships, including some carrying provisions to Narses, new commander of the operations in Italy. The Imperial commander at Ravenna sent a message to the Magister Militum Iohnnes at Salones asking him to relieve Indoulph's siege of Ancona and Iohnnes manned 38 *ploia makra* and sailed from Salones. The Goths at Ancona sailed out to give battle and the two fleets met off Sena Gallica in the only naval engagement of the war, the Goths being defeated and only 11 ships under Indoulph escaping.

The ships were burned to prevent their falling into Imperial hands, which led to the abandonment of the siege of Ancona: Procopius wrote that Senigallia broke the spirit and weakened the power of Totila and the Goths. However Totila could still assemble a fleet to send to Corsica and Sardinia. The conquest of Sardinia and Corsica by Totila in 551 was a hard defeat for Justinian's commanders.



From this position, the Ostrogothic ships could easily threaten the Roman ways of communication between the Eastern and the Western Mediterranean. The Roman commander in Libya, the Magister Militum and Patricius Iohannes Troglita, sent a fleet against them but was defeated outside Cagliari and retired to Carthage (Procopios, BG VIII.xxii.17–32, VIII.xxiii.4–9, VIII.xxiii.10–38, VIII.xxiii.42, VIII.xxiv.3, VIII.xxiv.31–6). In the end the war was decided by Narses' decisive land victories at Busta Gallorum and Mount Vesuvius in 552.

F ROMAN NAVAL ACTIONS AGAINST THE BOSPHOREAN GOTHS, 252 AD



The scene shows Roman river ships intercepting Gothic raiders. The Goths sailed together in groups of a dozen strong and with hundreds of men. The Roman ships were obviously stronger and superior, but the marauders, who moved on small flat-bottomed ships, were difficult to intercept because of the area in which they operated and the frequency of the raids. In this scene a small Roman *moneres liburna* is attacking and burning a Gothic ship.



During the campaign, when the army arrived at the artificial river called Naarmalcha, Julianus 'unloaded the stronger ships of those which carried provisions and artillery, and manned them each with eight hundred armed soldiers; then keeping by him the stronger part of the fleet, which he had formed into three divisions, in the first quiet of night he sent one part under Count Victor with orders speedily to cross the river and take possession of the enemy's side of the stream.'

Notwithstanding the protests of his generals, who were afraid for his life, the flag was raised according to his orders, and five ships immediately vanished from sight. But no sooner had they reached the opposite bank than they were assailed so persistently with firebrands and every kind of inflammable material, 'that ships and soldiers would have been consumed, had not the emperor, carried away by the keen vigour of his spirit, cried out that our soldiers had, as directed, raised the signal that they were already in possession of the shore, and ordered the entire fleet to hasten to the spot with all the speed of their oars.' The result was that the ships were saved undamaged, and the surviving soldiers, although assailed from above with stones and every kind of missile, after a fierce struggle scaled the high, precipitous banks and held their positions unyieldingly. The combined employment of the fleet beside the army was one of the elements revealing the great strategic capacity of the unlucky emperor. The ships illustrated in the scene are of the *pentekonteris* and *triakonteris* type.

H THE ROMAN FLEET DESTROYS THE OSTROGOTHIC NAVY AT THE BATTLE OF SENA GALLICA, WINTER 551 AD



*Dhromones* were apparently capable of being deployed during the winter months, typically a time of turbulent seas in the Mediterranean. Winter deployment was probably necessitated by the increased threats on the sea from the third century onwards. This expanded time of operation, possibly to year-round duty, created new demands on warship design and maintenance. In order to achieve decent stability in the rougher winter seas, these ships must have had suitable length-beam coefficients and draughts, with adequate freeboard below the levels of oar ports to prevent flooding.

The *dhromones* of the emperor are here copied from the miniatures of the Ilias Ambrosiana, and reconstructed according to Bonino and Viereck. Note the employment of the marine fire beside the more usual fire machines, such as catapults and scorpions.

# BIBLIOGRAPHY

## Ancient Roman sources

- Ammianus Marcellinus (Amm. Marc.), *The Histories-Res Gestae (Hist.)*, trans. by J. C. Rolfe, 3 vols, Harvard University Press (London, 1939–50)
- Cassius Dio, *Roman History – Romaika (Rom.)* trans. by E. Cary, 9 vols, Harvard University Press (London, 1914–27)
- Corpus Inscriptionum Latinorum (CIL), *Consilio et Auctoritate Academiae Litterarum (Scientiarum) Regiae Borussicae (Germanicae)*, apud Georgium Reimerum, 17 vol. in 73 tomes, de Gruyter (Berlin, 1869–1987)
- Florus, *Epitome of Roman History – Epitome de T. Livio Bellorum Omnium Annorum DCC Libri Duo (Epit.)*, trans. by E. S. Forster, Harvard University Press (London, 1984)
- Herodian, *History of the Empire, Books I–IV*, trans. by E. C. Echols, Harvard University Press (London, 1961)
- Marcellinus Comes, *Chronicon*, ed. T. Mommsen (Berlin, 1894): trans. B. Croke as *The Chronicle of Marcellinus*, Australian Association for Byzantine Studies, (Sydney, 1995)
- Maurus Servius Honoratus, *In Vergilii carmina comentarii. Servii Grammatici qui feruntur in Vergilii carmina commentarii*, ed. George Thilo and Herman Hagen, B. G. Teubner (Leipzig, 1881)
- Orosius, *The Seven Books of History against the Pagans*, ed. R. J. Deferrari, Catholic University of America Press, (Washington, 1964)
- Priscus, *Works*, in *The Fragmentary Classicising Historians of the later Roman Empire*, volume 2, ed. R. Blockley, ARCA Classical and Medieval Texts, Papers, and Monographs 10 (Liverpool, 1983), 345–79
- Procopius, *History of the Wars*, 5 volumes (BV = *Bellum Vandalicum*; BG = *Bellum Gothicum*), trans. by H. B. Dewing, Harvard University Press (London, 1914–28)
- Scriptores Historia Augusta*, trans. by D. Magie, 3 vols., Harvard University Press (London, 1921–60)
- Syncellus, *The Chronography of George Synkellos: A Byzantine Chronicle of Universal History from the Creation*, ed. W. Adler and P. Tuffin, Oxford University Press (Oxford, 2002)
- Vegetius (Veg.), Flavius Renatus, *Military Art – Epitoma Rei Militaris/De Re Militari (Epit.)*, in *Vegetius Epitoma Rei Militaris*, ed. M. D. Reeve (Oxford, 2004)
- Zonarás, *Epitome Historiarum*, ed. L. Dindorf, 6 vols. (Leipzig, 1868–75)
- Zosimus, *New History*, ed. R. T. Ridley, Australian Association for Byzantine Studies (Sydney, 1982)

## Modern works

- Anderson, R. C., *Oared Fighting Ships*, P. Marshall (London, 1962)
- Bèjaoui, F., S. Ben Mansour, M. H. Fantar, L. Foucher, F. Ghedini, N. Jeddi, M. Khanoussi, G. C. Picard, H. Slim and M. Yakoub, *I mosaici Romani di Tunisia*, Jaka Book (Paris, 1994)
- Bonino, M., *Archeologia e tradizione navale tra la Romagna ed il Po* (Ravenna, 1978)
- Campbell, B., *War and Society in Imperial Rome, 31 BC–AD 284* (London/New York, 2002)
- Carro, D., ‘Appendici Marittime’, in *Classica, Storia della marina di Roma, Testimonianze dell’antichità*, XI (Rome, 2002)
- Casson, L., *Ancient Mariners, Mediterranean in Ancient Times* (New York, 1959)
- Cervellati, N., *I diplomi militari: una fonte epigrafica ufficiale per lo studio delle flotte provinciali romane*, PhD thesis (Bologna, 2009)

- D'Amato, R., *Imperial Roman Naval Forces 31 BC–AD 500* (Oxford, 2009)
- Daremberg-Saglio, *Dictionnaire des Antiquités Grecques et Romaines* (Paris, 1877–1919)
- Frediani, A., *L'ultima battaglia dell'Impero Romano* (Rome, 2010)
- Henniquiau, M., and J. Martin, *La Marine Antique (2)* (Pantin, 1999)
- Höckmann, O., 'Late Roman River Craft from Mainz, Germany,' in O. L. Filgueiras, *Local Boats: Fourth International Symposium on Boat and Ship Archaeology, Porto /985* British Archaeology Report International Series 438i (Oxford, 1988), 23–33;
- Konstam, A., *Byzantine Warship vs. Arab Warship, 7th–11th Century* (Oxford, 2015)
- La Mantia, *il Dromone* (Milano, 2008)
- Mason, D. J. P., *Roman Britain and the Roman Navy* (Stroud, 2003)
- Morrison, J. S. and R. Gardiner (eds.), *The Age of the Galley: Mediterranean Oared Vessels Since Pre-Classical Times*, Conway Maritime (London, 1995)
- Morrison, J. S. and J. F. Coates, *Greek and Roman Oared Warships* (Oxford, 1996)
- Pitassi, M., *The Navies of Rome* (Chippenham and Eastbourne, 2009)
- Pomey, P., 'Le navire romaine de la Madrague de Giens', *Comptes Rendus de l'Académie des Inscriptions* (January–March 1982), 133–154.
- Pryor, J. H. and E. M. Jeffreys, *The Age of the Dhromon, The Byzantine Navy 500–1204* (Leiden–Boston, 2006)
- Reddé M., *Mare Nostrum: les infrastructures, le dispositif et l'histoire de la marine militaire sous l'empire romain*, Bibliothèque des Écoles françaises d'Athènes et de Rome CCLX (Rome, 1986)
- Royal, J. G., *The Development and Utilization of Ship Technology in the Roman World in Late Antiquity: Third to Seventh Century AD* (Texas A&M University, 2002)
- Starr, C. G., *The influence of Sea Power on Ancient History* (Oxford, 1989)
- Starr, C. G., *The Roman Imperial Navy, 31 BC–AD 324* (Chicago, 1993)
- Viereck, H. D. L., *Die römische Flotte, Classis Romana* (Hamburg, 1996)
- Welsby, D. A., *The Roman Military Defence of the British Provinces in its Later Phases*, in British Archaeology Report British, Series 101 (Oxford, 1982)

## **ABOUT THE AUTHOR**

Dr Raffaele D'Amato is an experienced researcher of the ancient and medieval military worlds. After achieving his first PhD in Romano-Byzantine Law, and having collaborated with the University of Athens, he gained a second doctorate in Roman military archaeology. He currently works in Istanbul at the Fatih University as visiting Professor for the TUBITAK (Turkish Government Research Institution) on a project linked to the arms and armour of Rome and Byzantium.

# ILLUSTRATOR

Giuseppe Rava was born in Faenza in 1963, and took an interest in all things military from an early age. entirely self-taught, Giuseppe has established himself as a leading military history artist, and is inspired by the works of Detaille, Meissonier, Röchling, Lady Butler, Ottenfeld and Angus McBride. He lives and works in Italy. For more on Giuseppe, please visit his website at [www.g-rava.it](http://www.g-rava.it)



# ACKNOWLEDGEMENTS

A great number of people, museums, and institutions have contributed again to this, my third volume on Roman warships. Very special thanks must be given to Admiral Domenico Carro, who once more shared with me his precious knowledge of the Roman navy, and enriched the book with his wonderful illustrations. Professor Livio Zerbini of Ferrara University has as always given his invaluable help in obtaining, from different museums and institutions, permission to see and photograph the related material in their collections. The material from the Bardo and Tunisia museums I owe to the kindness of my dear colleague and friend, the conservator of the Museum of Carthage, Hamden Ben Rhomdane. The magnificent photograph of the Naval Battle from the Museum of Algeri is thanks to the skill and courtesy of my dear friend Oulmi Med Lakhdar, professor of the University of Algiers.

To the Ancient Forum Coins I owe the splendid coins which are reproduced in the book. Particular thanks must be given to the Museum für Antike Schifffahrt des RGZM, Mainz, for the magnificent photos and permission to reproduce them in this book.

For the photographic credits I would like to thank the following museums and institutions: the Archaeological Museum of Ephes; the National Museum of Pozarevac; the British Museum; the Museum of Constantina-Cirta; the Museums of the Villa del Casale at Piazza Armerina; the Low Ham Villa Museum; the Biblioteca Apostolica Vaticana; the Zeugma Mosaic Museum; the Bodleian Library; the Naval Museum of Madrid; and the Biblioteca Ambrosiana of Milano. Special thanks must be given also to Dr Andrea Salimbeti and Dr Massimo Bizzarri for their always precious assistance and inestimable help in collecting the photographic material, in researching the sources, in preparing the drawings, in patiently assisting in my various travels and in many other numerous ways. Last but not least, I am deeply grateful to my dear friend and illustrator Giuseppe Rava for providing a splendid new set of illustrations on the previously obscure subject of the late Imperial Roman navy.

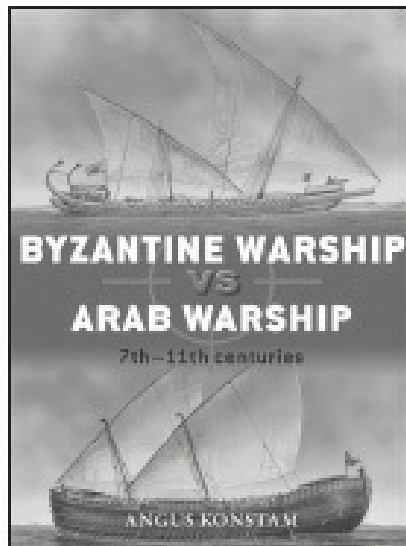

**DUE No: 64 • ISBN: 978 1 4728 0757 1**

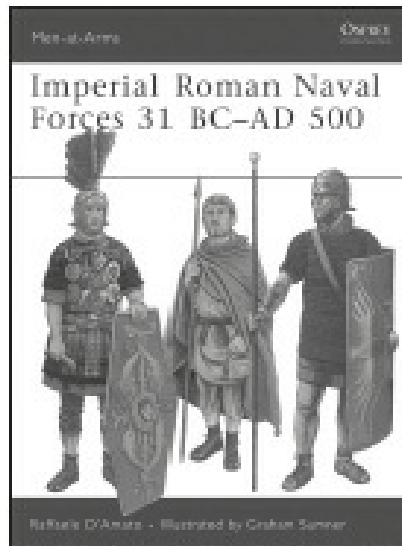

**MAA No: 451 • ISBN: 978 1 84903 317 9**

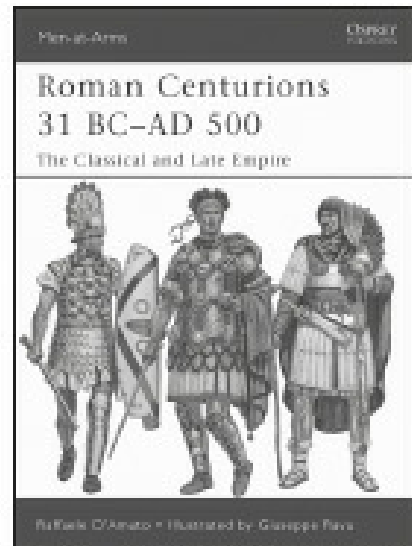

**MAA No: 479 • ISBN: 978 1 84908 795 7**

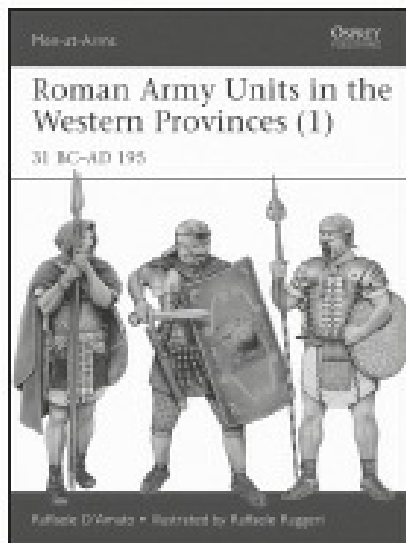

**MAA No: 506 • ISBN: 978 1 4728 1537 8**

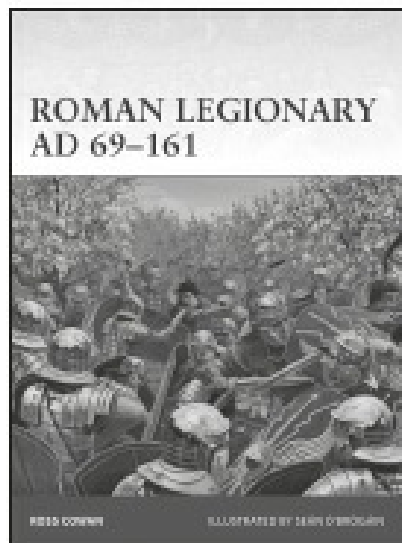

**WAR No: 166 • ISBN: 978 1 78096 587 1**

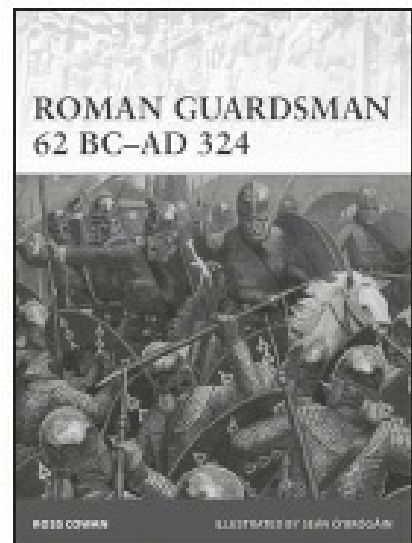

**WAR No: 170 • ISBN: 978 1 78200 925 2**

# Other titles in the series

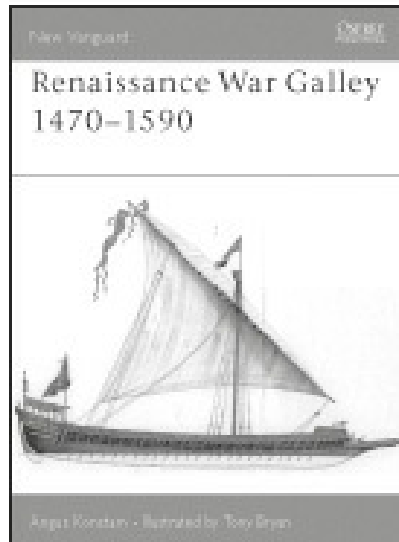

**NVG No: 62 • ISBN: 978 1 84176 443 6**

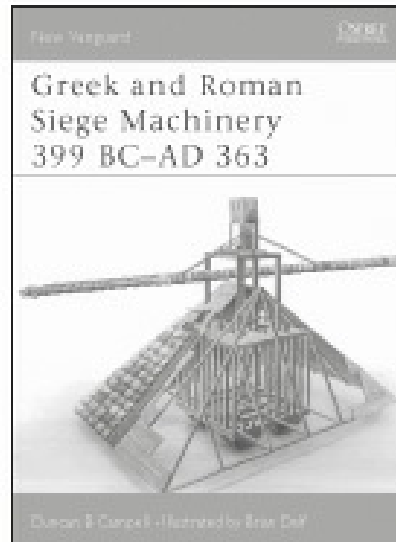

**NVG No: 78 • ISBN: 978 1 84176 605 8**

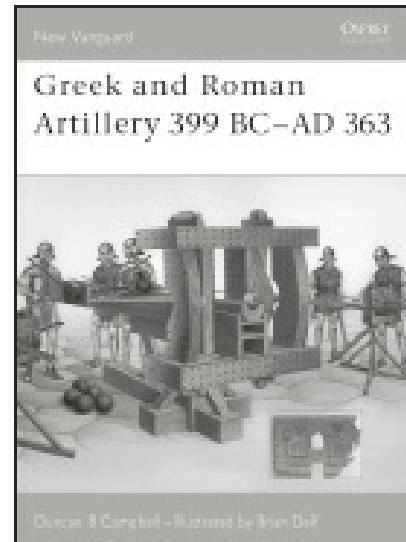

**NVG No: 88 • ISBN: 978 1 84176 634 8**

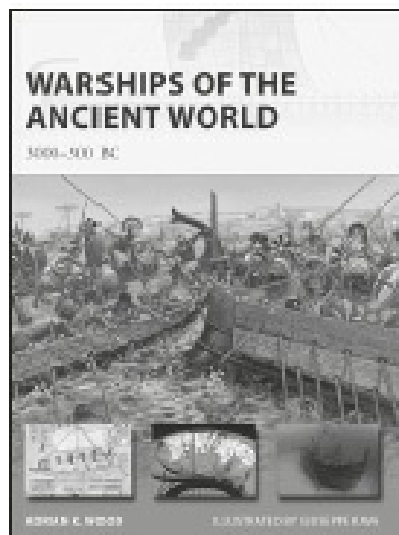

**NVG No: 196 • ISBN: 978 1 84908 978 4**

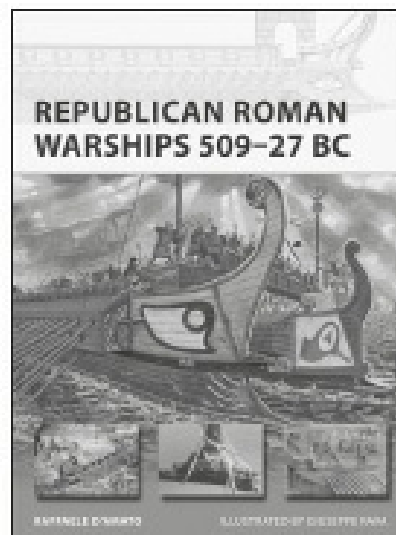

**NVG No: 225 • ISBN: 978 1 4728 0827 1**

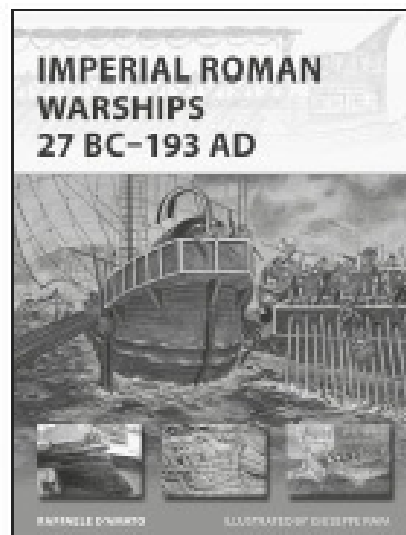

**NVG No: 230 • ISBN: 978 1 4728 1089 2**

First published in Great Britain in 2017 by Osprey Publishing.

PO Box 883, Oxford, OX1 9PL, UK

1385 Broadway, 5th Floor, New York, NY 10018, USA

E-mail: [info@ospreypublishing.com](mailto:info@ospreypublishing.com)

Osprey Publishing, part of Bloomsbury Publishing Plc

OSPREY is a trademark of Osprey Publishing, a division of Bloomsbury Publishing Plc

© 2017 Osprey Publishing Ltd

All rights reserved. Apart from any fair dealing for the purpose of private study, research, criticism or review, as permitted under the Copyright, Designs and Patents Act, 1988, no part of this publication may be reproduced, stored in a retrieval system, or transmitted in any form or by any means, electronic, electrical, chemical, mechanical, optical, photocopying, recording or otherwise, without the prior written permission of the copyright owner. Enquiries should be addressed to the Publisher.

A CIP catalogue record for this book is available from the British Library.

Print ISBN: 978 1 47281 826 3

ePDF ISBN: 978 1 47281 827 0

eBook ISBN: 978 1 4728 1 828 7

XML ISBN: 978 1 4728 2 480 6

Osprey Publishing supports the Woodland Trust, the UK's leading woodland conservation charity. Between 2014 and 2018 our donations are being spent on their Centenary Woods project in the UK.

To find out more about our authors and books visit [www.ospreypublishing.com](http://www.ospreypublishing.com). Here you will find extracts, author interviews, details of forthcoming events and the option to sign up for our newsletter.