

Ruins & Adventures

Short Adventure Locations

The Sanctuary



The ruins of a small village hide a dark secret.

**Mesozoic
Press**

B/X ESSENTIALS
Compatible Product

Ruins & Adventures

The Sanctuary



B/X ESSENTIALS
Compatible Product

B/X Essentials is a trademark of Gavin Norman.
The trademark and compatibility logo are used with
permission of Necrotic Gnome, under license.

How to Use This Series

The *Ruins & Adventures* series is intended to be dropped into an existing campaign as encounters and events that occur during their travels. While each one is self contained, they contain advice on how to further expand upon the events. Each entry is set out in the following format:

- Important information about the area, such as locked doors.
- Read aloud text highlighted in grey.
- **Trap:** Any traps in the area.
- **Encounter:** Any dangerous creatures in the area along with their XP reward.
- **Treasure:** Any treasure that can be found in the area.
- **Development:** Anything that may cause changes to the locations depending on the PCs actions.

What Actually Happened Here

Fifty years ago strange dreams of an extra-planar entity began to plague a minor noble named Tralazar. Each night he was tormented by a whispering voice promising him power and strength in exchange for sacrifice and death. After a month, his will in tatters, Tralazar began to listen.

Soon the killings began, starting with beggars and commoners but when the whispers wanted more Tralazar killed seven members of own family along with six servants and for the first time heard the voice in the waking world. Power flowed through him and Tralazar named himself a cleric of the Unknown and set about recruiting a small group of acolytes to further his masters will.

As the death toll grew the authorities began to take notice so Tralazar decided to retreat to the wilderness and begin construction of a hidden sanctuary dedicated to his otherworldly master. Rather than doing the work themselves the cult kidnapped travellers passing along the nearby roads, using them for forced labour until they dropped when the cult's mages would animate them into tireless undead slaves. Black marble was brought in from some far off shore to line the ceiling, walls and floors and after two years

the sanctuary was finally completed.

A summoning chamber had been constructed even deeper into the earth so Tralazar was able to perform a special ritual the Unknown promised would bring him ultimate power. For days at a time Tralazar chanted in the chamber while his acolytes added their prayers from a shrine above.

After a week Tralazar finally felt a surge of energy wash over him and a loud boom echoed throughout the halls, then silence. The acolytes hesitated before daring to venture into the lower chamber. Opening the huge gold doors there was no sign of Tralazar on the platform and as one mage approached the edge a huge fleshy tentacle seized him, dragging to the floor below. As the mage's scream died the vile amorphous form of Tralazar revealed itself. Instead of summoning the Unknown Tralazar had been transformed into its likeness, shattering his sanity in the process.

Without Tralazar's guidance his followers were unsure of what to do next. The mage that had fell victim to Tralazar's grasp had been drained of his life energy before being returned as a twisted undead version of his former self. The process seemed to mollify Tralazar so the acolytes decided to continue feeding him, kidnapping more travellers in order to do so. Over the course of two months the group lost a further two members to Tralazar's indiscriminate rage so those remaining decided that the pay off for years of devotion was lacking and left the sanctuary, burying the entrance under a small hill where it lay undisturbed for a further 30 years.

When a small groups of farmers set off from the smouldering remains of their village that had been destroyed by an orc raiding party, they had set their hearts on starting a new life by rebuilding in a safer location. After wandering the wilderness for several days they stumbled on a small clearing near a hill a day or so from the nearest road that seemed like an ideal location and when they discovered piles of black marble stone ideal for building their new homes they counted their blessings and started immediately. Over the course of the next few

days the seven small houses began to take shape but as their supplies were running low they decided to start on a new well in the soft earth near the base of the hill. As they dug deeper they found themselves coming up against some hard black stone that before long fell to their pickaxes and revealed a dark structure seemingly built thirty feet beneath them. Bewildered by their discovery and driven by tales of lost treasures and riches two of the farmers lowered themselves down into the darkness unaware of the dangers that would be found there.

The hole brought them through the ceiling of a large black stone room covered in cracks with water running down the walls and moss and slime covering everywhere. Lighting their torches the farmers ventured further through a dark wooden door. That was the last that was seen of them. None of the other farmers found out what had happened in the darkness below their feet but screams of agony echoed from the well soon after they disappeared from sight. This proved too much for those left above who had already lost too much from various hardships and with a heavy heart they left their new home hoping their next stop would prove to be truly safe.

The Village

The village can be placed in any wooded area about a day's travel from any major road or town.

Just ahead of you it is easy to make out several black stone walls silhouetted against the trees of the forest. As you push forward you find the walls appear to be the ruins of seven small houses set out in a circular pattern on the edge of a small clearing jutting up against a small hill. Each of the houses look like they were only partially finished, with stones, rotted timbers and even tools lying nearby. In the center of the clearing surrounded by a few loose stones is a hole in the ground about 3 feet across, easily identified as a half-built well.

- **Treasure:** A successful search of the houses discovers 4gp among the broken tools.
- **Development:** Climbing down the well leads

to area 1 thirty feet below and requires a secured rope or a successful Climb Walls or Dex check. A failure means falling to the floor below and suffering 3d6 points of damage.

The Sanctuary

- Unless stated otherwise all of the walls, floors and ceilings are made from black marble with the corridors and rooms standing 10 ft. high.
- Each door has a lock but is unlocked and made from black stained wood reinforced with iron (AC: 4, hp: 20).
- The stone floors of the sanctuary are slick with water and slime. Any creatures moving faster than a single move must make a Save vs. Breath or fall prone, taking 1d6 points of damage.

1) Store Room

After descending the 30 ft. down the rough hewn well you emerge through the ceiling of a room clad in black marble. Broken ceiling slabs lay smashed on the floor below the hole while the rest of the floor appears to be cracked and covered in small pools of stagnant water. Moss and slime cover most of the stonework. A set of rotted wooden shelves line the north wall holding dusty jars and pots. Two large weapon racks stand against the west wall holding a few rusted spears and swords and two half filled sacks stand next to a door in the east wall.

- **Treasure:** The weapons are rusted beyond use and the jars and pots contain spoiled food. The two sacks contain bug ridden grain. A successful search of the room reveals 3gp in a few gaps in the floor.

2) Statue

A black marble statue sits in a small alcove between two doors on the west wall of the corridor. The life size sculpture depicts a cloaked figure wearing chain mail armor with a mace hanging from his belt. Both hands are held out towards the corridor holding a circular dish with a hole in the center. The statue's head has been broken off at the neck and the remains lay scattered at the statue's feet.

The statue is of Tralazar before his transformation and is one of many in the

Upper Floor

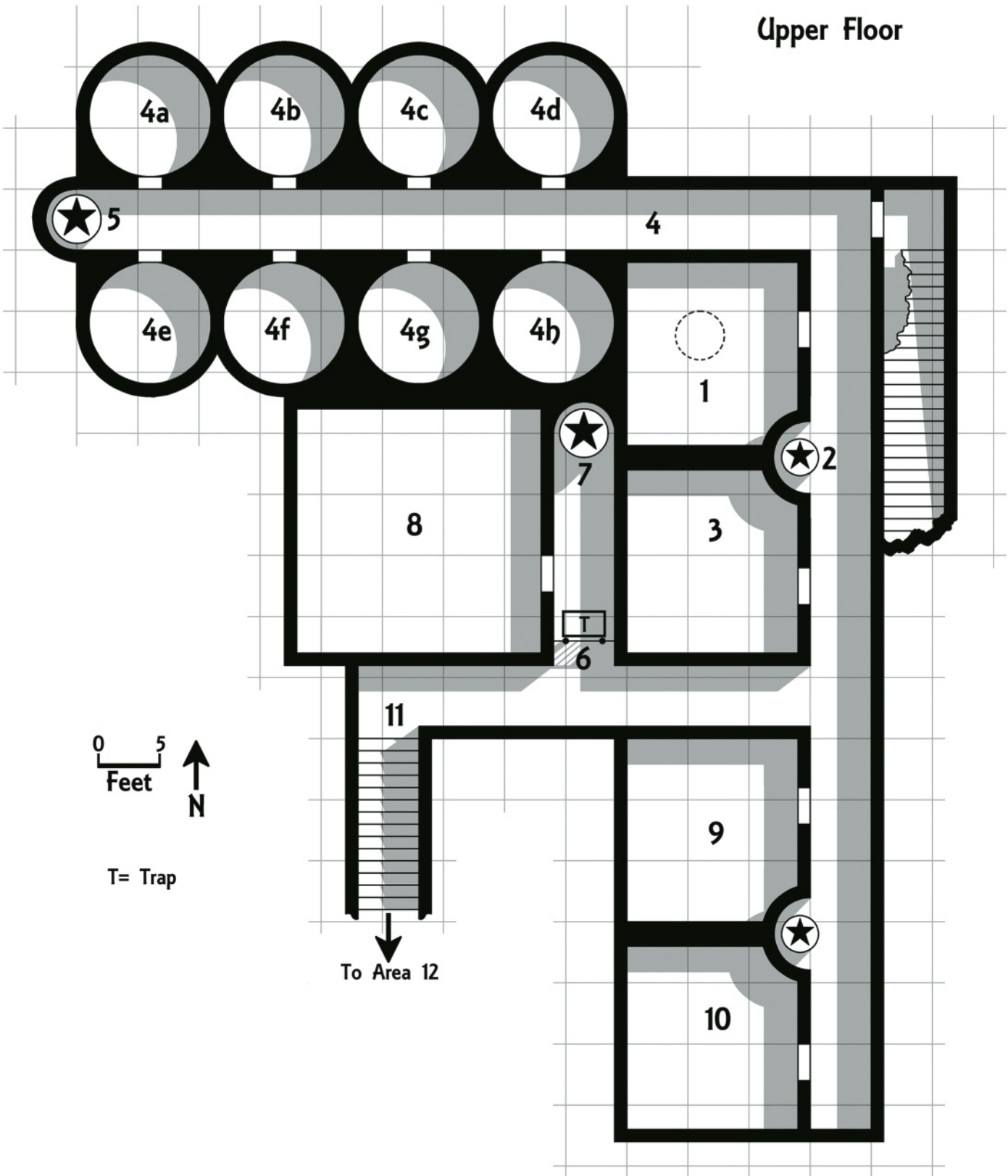

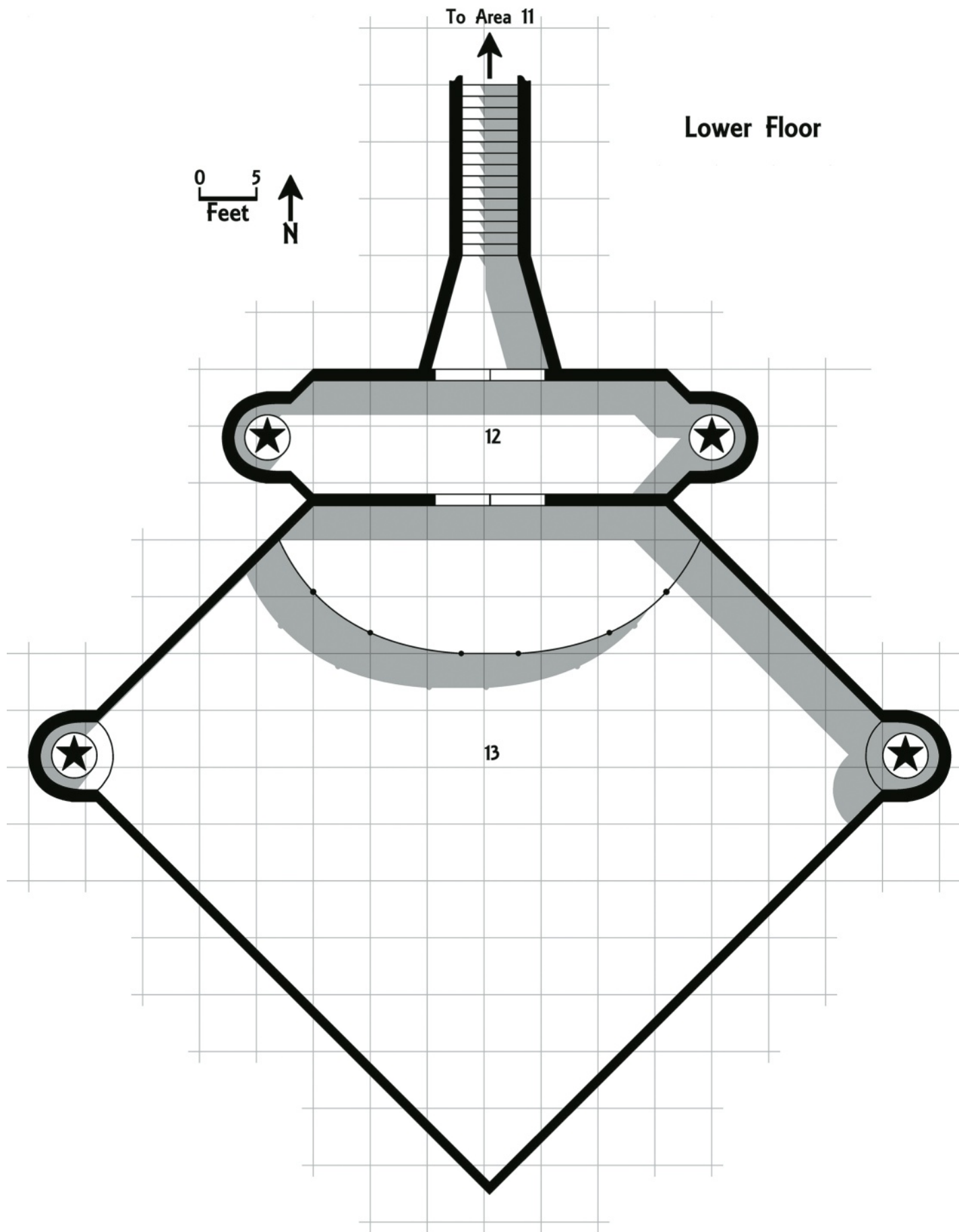

sanctuary. The head of the statue was destroyed by Tralazar in a fit of rage when he could no longer bear to see his original form.

The small hole in the center of the dish once held a candle and a small amount of wax can be found in the recess.

) Tralazar's Room

This room is locked and the door is cracked.

A large rotten bed lay against the west wall of this large room while a small writing desk sits against the east wall holding a few quill pens, ink pots and a large leather bound book. A 3 ft. by 4 ft. painting of a blonde man in chainmail dominates the north wall, his gaze seeming to survey the entire room with a sinister smile playing across his lips. Two chests, one significantly larger than the other stand against the south wall.

- **Treasure:** There are four dried ink pots on the writing desk each with a silver collar worth 5gp each. The leather bound book is heavily water damaged and is actually a diary of all Tralazar's accomplishments. Most of the passages are unreadable but the GM can give the PCs any of Tralazar's background from the *What is Really Happening* section, all written in Tralazar's fragile mind set.

The painting is of Tralazar and was completed a month before his transformation by a particularly famous painter named Castilo Reymon from a nearby city. It is worth between 1000 to 2000gp to the right buyer.

The large chest contains mostly clothing, all of which is water damaged but tucked away at the bottom are two dark red potions (*potions of longevity*).

The small chest is locked. Inside are two sacks containing a total of 300gp. Under the sacks, wrapped in a white cloth is a *dagger +1* with a gold hilt in the shaped of a lion.

4) Acolytes Quarters

Four identical doors stand either side of this corridor and a broken statue stands in an alcove at the west end.

The statue is another image of Tralazar (see

area 5).

4a) This circular room contains the remains of a small straw filled bed and a simple set of shelves.

4b) This circular room contains the remains of a wooden table and some shelves gathered into three small piles upon the floor.

- **Treasure:** 3gp can be found among the debris.

4c) A lone cloaked figure stands in this otherwise empty room before rushing towards you with its arms outstretched to attack.

- **Encounter:** This room contains an acolyte transformed into a **husk** (see page 10). **35 XP**.

- **Treasure:** The husk is carrying a small pouch containing 27sp and a small red ruby worth 50gp.

4d) The door to this room is locked.

Rivulets of water run down the walls of this empty circular room and small pools have gathered in the cracks around the flagstone in the room's center.

- **Encounter:** A large **insect swarm** (HD: 4, 18hp) live in the cracks in the ceiling of this room and will swarm down to attack anyone nearby. **75 XP**.

- **Treasure:** Lifting the loose flagstone in the floor reveals a small rusted iron box sitting in a small hole. Once it is either broken or pried open the PCs can find 177gp and a silver ring worth 60gp.

4e) The door to this room is ajar.

A human skeleton is sprawled across the floor of this otherwise empty room. It's simple clothing is tattered and rotten suggesting it has been here for quite some time.

- **Treasure:** The remains belong to one of the farmers that was killed by a husk nearly 20 years ago. A small pouch on his belt contains 3cp.

4f) The hinges on this door are badly rusted. Anyone attempting to open it will cause it to fall noisily into the room beyond possibly alerting nearby creatures.

Rivulets of water run down the walls of this empty room pooling among the cracks in the floor.

4g) The door to this room refuses to open as if blocked by something inside.

Treasure: Most of the ceiling of this room has collapsed piling marble blocks, stones and dirt behind the door. If the PCs manage to get inside (by removing the door etc.) they may search the room by digging for an hour in the debris. If they are successful they discover 23gp spread around the room.

4h) Small pieces of marble are pushed aside as you open this door and glancing in you can see that they come from holes in the ceiling. A heavily rooted wooden bed frame stands against the east wall while a small wooden box sits against the south wall.

- **Development:** The ceiling to this room is unstable and for every round a PC spends inside there is a 2-in-6 chance that it will collapse bringing down marble, stone and dirt and causing 4d6 points of damage. A successful Save vs. Breath reduces the damage by half.

- **Treasure:** The small wooden box contains a wooden flute with two small diamonds worth 100gp each tucked into the lining.

5) Statue

This statue seems to be the same cloaked figure seen elsewhere but it is even more damaged, having been broken in half at the waist. While it is impossible to identify the figure from the pieces of stone on the ground it can easily be made out that it once held a candle and a book.

This is another statue of Tralazar destroyed by him during his rages. The book he holds is the same one found in area 3.

6) Gate

This gate is locked.

A black metal gate hangs across this corridor running floor to ceiling. Another life sized statue is in an alcove opposite while a door lies beyond the gate on the west wall.

- **Development:** The gate can be opened by the key found among Tralazar's items in area 13 or by making a successful pick locks check.

- **Trap:** There is a pressure plate on the floor just inside the gate and anyone passing over it has a 2-in-6 chance of setting the trap off. When it's activated holes in the ceiling spill acid onto any creature between the statue and the gate causing 2d6 points of damage. A successful Save vs. Breath reduces the damage to half.

The trap can be disabled by blocking the holes in the ceiling (there are 20 of them), jamming the pressure plate, or by using the gate key in a small keyhole on the floor just inside the gate. A successful find traps check reveals all these methods.

7) Statue

This statue doesn't have any of the damage found on the others and depicts a cloaked man wearing chainmail wielding a mace that he points down the corridor towards the gate.

This is the only Statue that Tralazar didn't destroy as somewhere in the back of his consciousness was the memory that the area was dangerous.

8) Vault

This room is locked.

The door to this room is heavily reinforced with extra steel plates.

The door is AC: 2, hp: 30.

Once the PCs are inside read the following:

Rows of chests line the north, west and south walls, three on each side, while a sturdy looking table with a small wooden box sitting on it stands in the room's center.

- **Treasure:** All of the chests are unlocked but

most of their contents were taken by Tralazar's acolytes when they left the sanctuary.

Chest 1: A gold ring worth 50gp has been caught up among several old sacks.

Chest 2: A small bag contains 15gp along with 2 gold necklaces worth 500gp each.

Chest 3: A small sack contains 65cp and 35sp.

Chest 4: Empty

Chest 5: 4gp lay at the bottom of the chest.

Chest 6: Empty

Wooden Box: This box is locked (AC: 8, hp 5). Resting upon a purple velvet interior are two enamel and gold discs with space for a third. One has a fire design upon it, the second an ice design. These are two *elemental coins* (see page 10), the third is attached to Tralazar's mace in area 13.

9) Shrine

The pungent stench of decay emanates from the room. Ten benches sit in five rows of two down the center of the room facing a small stone altar. Each bench holds one or two hunched cloaked figures, 15 in all, also facing towards the altar. Several brown cloaks lay discarded across the floor.

• **Encounter:** After Tralazar's transformation his shattered mind was convinced that he could draw more power from followers, even dead ones, and he instructed his undead attendants to move the bodies to the shrine set up in false reverence. Most of the bodies here are just the rotted remains of the cult's victims barely held together by their clothing but hidden among them are four **husks**. Even with new prey within their grasp they are able to hold back their ravenous hunger in an attempt to lure in any inquisitive PCs before pursuing anyone fleeing out of this room. **140 XP**.

• **Treasure:** The PCs are able to find a gold necklace worth 800gp and two gold rings worth 100gp each among the clothing of the dead.

10) Worker Storage

This door is locked.

The stench of death and decay radiates from this room as soon as the door is opened and the low murmur of gargled voices quickly joins it. Inside nine tattered undead push past each other to be the first to sink their teeth into their new victims.

• **Encounter:** This room contains 9 **zombies**, the remains of the civilians used to build the sanctuary kept from decaying by the magic that animated them. **180 XP**.

11) Stairs

Water runs in streams down these black marble stairs disappearing into the darkness below.

• **Development:** Tralazar's contact with another plane of existence has weakened the boundaries of reality somewhat and anyone passing more than three steps down needs to make a Save vs. Spells. Success means they continue down the stairs as normal. Those that fail experience the following visions, standing motionless on the third step for just a few seconds to anyone observing.

• The Vision

As you make your way downward each step seems to take you further into the darkness with no sign of stopping. Glancing back there is no sign of your companions and the stairs seem to stretch upwards towards infinity.

Any attempt to ascend the stairs seems to be never ending and only by continuing can the PC progress.

It is impossible to tell just how long you have been moving down the stairs but just as you think it will never end a corridor below comes into sight. The sound of your breathing is all you can hear but it is distorted and muffled. Ahead of you is a large set of gold lined doors engraved with an intricate circular design.

If the PC decides not to open the doors allow them a second Save vs. Spells. Success returns them to reality, standing on the third step. Failure means they are compelled to continue onwards.

As you push open the doors you find yourself in a wide room with a statue either side of you, their features hidden in the shadows. A second set of gold doors stands before you and you feel the need to see what is on the other side.

PCs may resist the compulsion again by making a third Save vs. Spells with success returning them to reality and a failure pushing them forward.

As you push open the second set of doors you find yourself on a black marble platform surrounded by a black metal fence and an open gate overlooking a pit of blackness that fills the rest of the room. Two more statues stand on high platforms gazing down towards you and for a second you are unable to tear yourself away from the darkness of the hooded faces. You then feel something brush against you leg and before you can see what it is you are pulled from your feet through the black metal gate and into the pit, tumbling endlessly downwards...

With a start you find yourself standing back on the stairs your heart racing uncontrollably.

Development: Any PC experiencing every stage of the vision is placed under the influence of the Unknown (see area 13).

12) Ante Chamber

A huge set of partially open gold lined doors stands before you etched upon them is a strange circular pattern.

Any PC experiencing the second stage of the vision will immediately recognise these doors. The doors open easily when pushed.

You find yourself in a wide ante chamber facing a second set of partially open gold lined doors. The remains of two statues of a cloaked human figure stand in alcoves, one either side of the room.

The statues are depictions of Tralazar before his transformation and once held candles to light the room but have once again been decimated by him.

Treasure: It is possible to remove the gold

from the door. Those wishing to keep the decoration intact with a value of 500gp per door would need to spend around an hour or so on each to do so. Taking less care means the job can be done in around 10 minutes per door but then each door is only worth 300gp. Any of these options will alert any creatures still left alive in the sanctuary.

13) Summoning Chamber

The door opens up to a vaguely diamond shaped room and you find yourself standing on a platform 10 ft. above the bone strewn floor below. A black metal fence and gate once blocked further entry into the room but the gate is now nothing more than twisted metal. Two broken statues depicting the same cloaked figure seen elsewhere stand on raised platforms in both the east and west corners.

Suddenly a strange creaking sound followed by a wet dragging noise can be heard from just below the platforms edge and two corpse-like creatures clamber towards you followed by an enormous mound of putrescent flesh. A single skull seems to silently scream from the mound while four huge tentacles seem to move with a life of their own.

The ceiling of this room is 20 ft. above the platform, 30 ft. above the lower part of the chamber.

The two statues are on platform 20 ft. above the lower floor and once again used to be depictions of Tralazar but have been broken over the years.

- **Encounter:** The PCs are attacked by **Tralazar** (see page 11), a **husk** and a **mage husk**. If the fight is proving too easy the GM may bring in additional husks drawn from the bone piles of Tralazar's previous victims as needed. **2,370 XP**.

- **Debris:** The lower part of the summoning room is covered with debris and the bones of Tralazar's victims and as such is treated as **difficult terrain**. Every 5' of movement costs 10' instead.

- **Development:** On the first round of combat

any PC that was put under the influence of the Unknown is -2 to attack while inside area 13. On subsequent rounds the PC may make another Save vs. Spells at the end of their turn to end the effect.

- **Treasure:** The PCs can find the following mixed among the piles of debris and filth:

A suit of damaged chainmail, a *mace +2* equipped with an *elemental coin of frost*, 56cp, 11sp and 50gp as well as the keys to the gate and vault room (areas 6 & 7).

Continuing the Adventure

Art Collectors: If the PCs attempt to sell the painting from Tralazar's room they are visited by the nephew of the original artist, Killian Reymont, who demands to hear what the PCs know about the disappearance of his uncle and several prominent sculptors 45 years ago. If the PCs are able to convince Killian that they found the item he has a few more pieces that he wishes for them to collect from old castles and homes across the land, many of which are reported to hold vicious and vile creatures.

The Whisperer in Darkness: A few days after the PCs leave the sanctuary one of them starts to experience strange dreams where he hears the whispers of some otherworldly voice...

New Magic Item

Elemental Coin

Going under the misnomer of actually being coins, these small circular items are usually made of gold and decorated with colorful enamel depicting flames, lightning and ice.

- When placed against a weapon the coin attaches itself and can only be removed by a minutes concentration which touching the coin.
- The weapon gains the ability to inflict an additional 1d6 points of damage of the type the coin depicts (fire, ice, and lightning).

New Monsters

Husk

The husk appears to be the desiccated remains of a human or similar creature with leathery skin stretched over its bones. It is normally found wearing the clothing or armor it died in and its limbs creak when it moves. The most common version is the warrior husk but creatures that are able to use magic are transformed into mage husks.

Husk: **AC:** 8 or by armor; **HD:** 3 (13hp); **ATT:** 2 x claws (1d4) + life drain; **ACO:** 17; **MV:** 90' (30'); **SV:** D12, W13, P14, B15, S16 (F1); **ML:** 12; **AL:** C; **XP:** 35; **NA:** 0 (0) **TT:** S

- **Life drain:** The husk grabs any creature hit by both claw attacks and steals its life energy in the form of black smoke leaving the victims mouth and transferring to the husk's. This attack inflicts an additional 1d6 points of damage each round the creature is Grappled. A creature can free itself by making a successful Strength check.

Mage husk

Mage husks have the same stats as above but are able to use the *dark energy bolt* attack listed below.

- **Dark energy bolt:** Once per round the mage husk is make a ranged attack against targets 120' away by hurling a ball of magical black energy at them. If the attack hits the target takes 1d6 points of damage.

Stat Block Abbreviations

AC= Armor Class, **HD**= Hit Dice (hp= Hit Points), **ATT**= attack type and damage, **ACO**= number needed to hit an opponent with an Armor Class of 0, **MV**= Movement Rate, **SV**= Saving Throw by class and level, **ML**= Morale, **XP**= Experience Points, **NA**= Number Appearing, **TT**= Treasure Type.

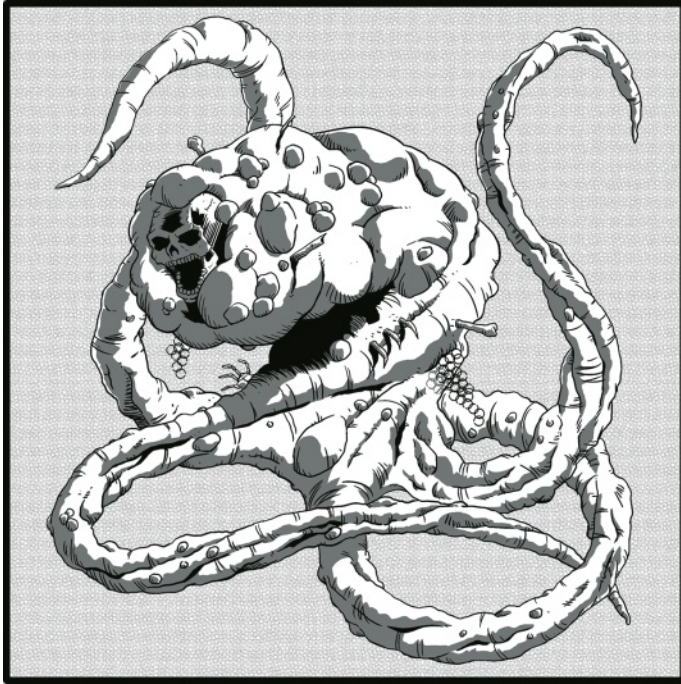

Tralazar

Once a minor noble from the city and now transformed into a terrible creature by an other-planar entity, Tralazar is now an enormous mound of putrefying flesh propelled by four tentacles that he can also use to attack with. Bones and armor pieces jut out of the flesh at strange angles and a skull can be seen near the front of the creature, its mouth hanging open as if to scream.

Tralazar: **AC:** 8; **HD:** 10** (45hp); **ATT:** 4 x tentacles (1d6) + grab & life drain; **ACO:** 11; **MV:** 60' (20'); **SV:** D6, W7, P8, B8, S10 (F10); **ML:** 10; **AL:** C; **XP:** 2,300; **NA:** 1 (unique) **TT:** Nil

- **Blindsight:** Tralazar can sense any creature within 60' but is blind otherwise.
- **Resistance to Bludgeoning Damage:** Tralazar takes half damage from any non-magical bludgeoning weapon.
- **Grab:** Any creature hit by one of Tralazar's tentacle attacks can be grabbed, reducing their movement to 0'. A tentacle grabbing a victim cannot be used to attack any other opponents. A victim can be freed by inflicting 8hp of damage to the tentacle or by making a successful Strength check.
- **Life drain:** While grabbed a victim takes 1d6 points of damage that is transferred to Tralazar healing him for the same amount. Creatures killed by the energy transfer return as husks under Tralazar's control 1d4 rounds later.

Open Game License

DESIGNATION OF PRODUCT IDENTITY

All artwork, logos, and presentation are product identity. The name "Ruins of Adventure" and "Mesozoic Press" are product identity. All text not declared as Open Game Content is product identity.

OPEN GAME LICENSE Version 1.0a

The following text is the property of Wizards of the Coast, Inc. and is Copyright 2000 Wizards of the Coast, Inc ("Wizards"). All Rights Reserved.

1. Definitions: "Contributors" means the copyright and/or trademark owners who have contributed Open Game Content; (b) "Derivative Material" means copyrighted material including derivative works and translations (including into other computer languages), potation, modification, correction, addition, extension, upgrade, improvement, compilation, abridgment or other form in which an existing work may be recast, transformed or adapted; (c) "Distribute" means to reproduce, license, rent, lease, sell, broadcast, publicly display, transmit or otherwise distribute; (d) "Open Game Content" means the game mechanic and includes the methods, procedures, processes and routines to the extent such content does not embody the Product Identity and is an enhancement over the prior art and any additional content clearly identified as Open Game Content by the Contributor, and means any work covered by this License, including translations and derivative works under copyright law, but specifically excludes Product Identity. (e) "Product Identity" means product and product line names, logos and identifying marks including trade dress; artifacts; creatures characters; stories, storylines, plots, thematic elements, dialogue, incidents, language, artwork, symbols, designs, depictions, likenesses, formats, poses, concepts, themes and graphic, photographic and other visual or audio representations; names and descriptions of characters, spells, enchantments, personalities, teams, personas, likenesses and special abilities; places, locations, environments, creatures, equipment, magical or supernatural abilities or effects, logos, symbols, or graphic designs; and any other trademark or registered trademark clearly identified as Product identity by the owner of the Product Identity, and which specifically excludes the Open Game Content; (f) "Trademark" means the logos, names, mark, sign, motto, designs that are used by a Contributor to identify itself or its products or the associated products contributed to the Open Game License by the Contributor (g) "Use", "Used" or "Using" means to use, Distribute, copy, edit, format, modify, translate and otherwise create Derivative Material of Open Game Content. (h) "You" or "Your" means the licensee in terms of this agreement.

2. The License: This License applies to any Open Game Content that contains a notice indicating that the Open Game Content may only be Used under and in terms of this License. You must affix such a notice to any Open Game Content that you Use. No terms may be added to or subtracted from this License except as described by the License itself. No other terms or conditions may be applied to any Open Game Content distributed using this License.

3. Offer and Acceptance: By Using the Open Game Content You indicate Your acceptance of the terms of this License.

4. Grant and Consideration: In consideration for agreeing to use this License, the Contributors grant You a perpetual, worldwide, royalty-free, non-exclusive license with the exact terms of this License to Use, the Open Game Content.

5. Representation of Authority to Contribute: If You are contributing original material as Open Game Content, You represent that Your Contributions are Your original creation and/or You have sufficient rights to grant the rights conveyed by this License.

6. Notice of License Copyright: You must update the COPYRIGHT NOTICE portion of this License to include the exact text of the COPYRIGHT NOTICE of any Open Game Content You are copying, modifying or distributing, and You must add the title, the copyright date, and the copyright holder's name to the COPYRIGHT NOTICE of any original Open Game Content you Distribute.

7. Use of Product Identity: You agree not to Use any Product Identity, including as an indication as to compatibility, except as expressly licensed in another, independent Agreement with the owner of each element of that Product Identity. You agree not to indicate compatibility or co-adaptability with any Trademark or Registered Trademark in conjunction with a work containing Open Game Content except as expressly licensed in another, independent Agreement with the owner of such Trademark or Registered Trademark. The use of any Product Identity in Open Game Content does not constitute a challenge to the ownership of that Product Identity. The owner of any Product Identity used in Open Game Content shall retain all rights, title and interest in and to that Product Identity.

8. Identification: If you distribute Open Game Content You must clearly indicate which portions of the work that you are distributing are Open Game Content.

9. Updating the License: Wizards or its designated Agents may publish updated versions of this License. You may use any authorized version of this License to copy, modify and distribute any Open Game Content originally distributed under any version of this License.

10. Copy of this License: You MUST include a copy of this License with every copy of the Open Game Content You Distribute.

11. Use of Contributor Credits: You may not market or advertise the Open Game Content using the name of any Contributor unless You have written permission from the Contributor to do so.

12. Inability to Comply: If it is impossible for You to comply with any of the terms of this License with respect to some or all of the Open Game Content due to statute, judicial order, or governmental regulation then You may not Use any Open Game Material so affected.

13. Termination: This License will terminate automatically if You fail to comply with all terms herein and fail to cure such breach within 30 days of becoming aware of the breach. All sublicenses shall survive the termination of this License.

14. Reformation: If any provision of this License is held to be unenforceable, such provision shall be reformed only to the extent necessary to make it enforceable.

15. COPYRIGHT NOTICE

Open Game License v 1.0 Copyright 2000, Wizards of the Coast, Inc. System Reference Document Copyright 2000, Wizards of the Coast, Inc.; Authors Jonathon Tweet, Monte Cook, Skip Williams, based on original material by E. Gary Gygax and Dave Arneson. System Reference Document Copyright 2000-2003, Wizards of the Coast, Inc.; Authors Jonathan Tweet, Monte Cook, Skip Williams, Rich Baker, Andy Collins, David Noonan, Rich Redman, Bruce R. Cordell, John D. Rateliff, Thomas Reid, James Wyatt, based on original material by E. Gary Gygax and Dave Arneson.

B/X Essentials: Core Rules © 2017 Gavin Norman.

Author Gavin Norman

B/X Essentials: Classes and Equipment © 2017 Gavin Norman. Author Gavin Norman.

B/X Essentials: Cleric and Magic-User Spells © 2017 Gavin Norman.

Author Gavin Norman.

B/X Essentials: Monsters © 2017 Gavin Norman, author Gavin Norman.

B/X Essentials: Adventures and Treasures © 2018 Gavin Norman,

author Gavin Norman.

Ruins & Adventures 1, 2, 3 © 2018, 2019 Mesozoic Press

END OF LICENSE

The following is designated as Product Identity, in accordance with Section 1(e) of the Open Game License, Version 1.0a: All Characters and their associated descriptions, backgrounds, and related information