

THE MORROW PROJECT



TIMELINE LTD

BULLETS & BLUEGRASS

A Complete Game Scenario
By TIMOTHY J. MCFADDEN and W.P. WORZEL

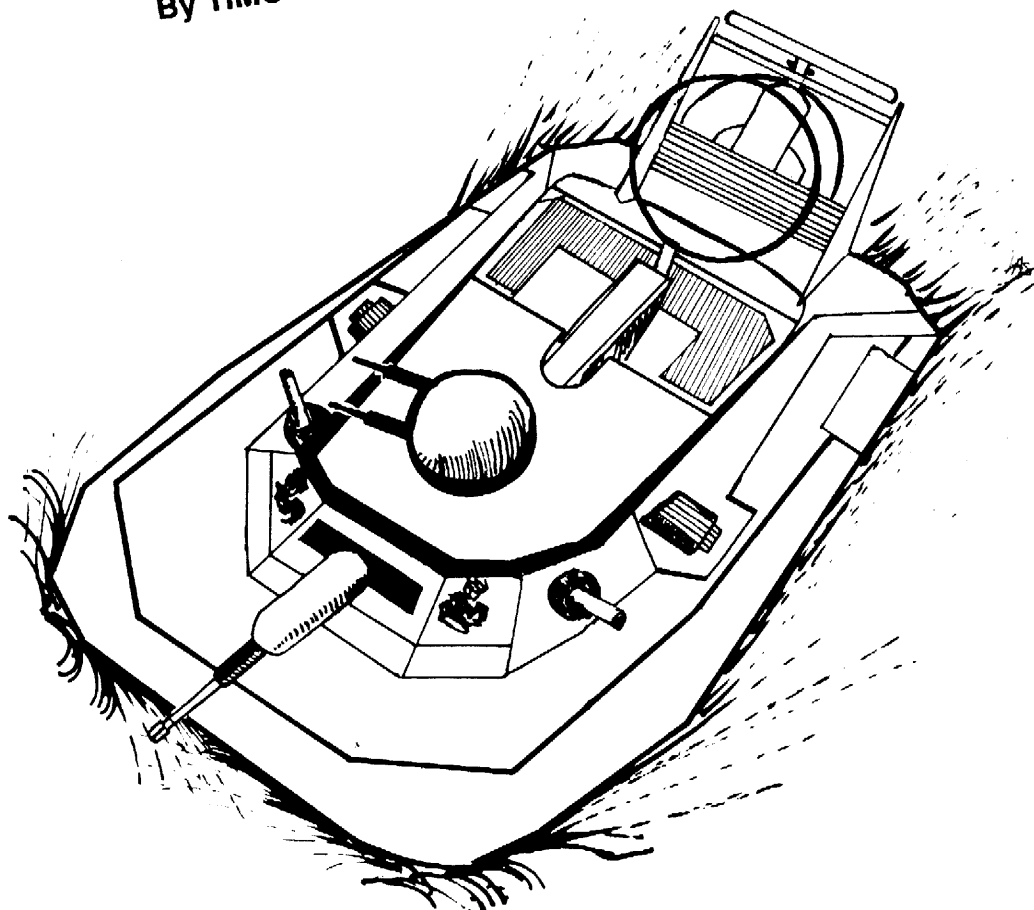

PRIOR POSSESSION OF THE MORROW PROJECT TM1-1
IS NECESSARY TO THE USE OF THIS MODULE

PROJECT FILE
009

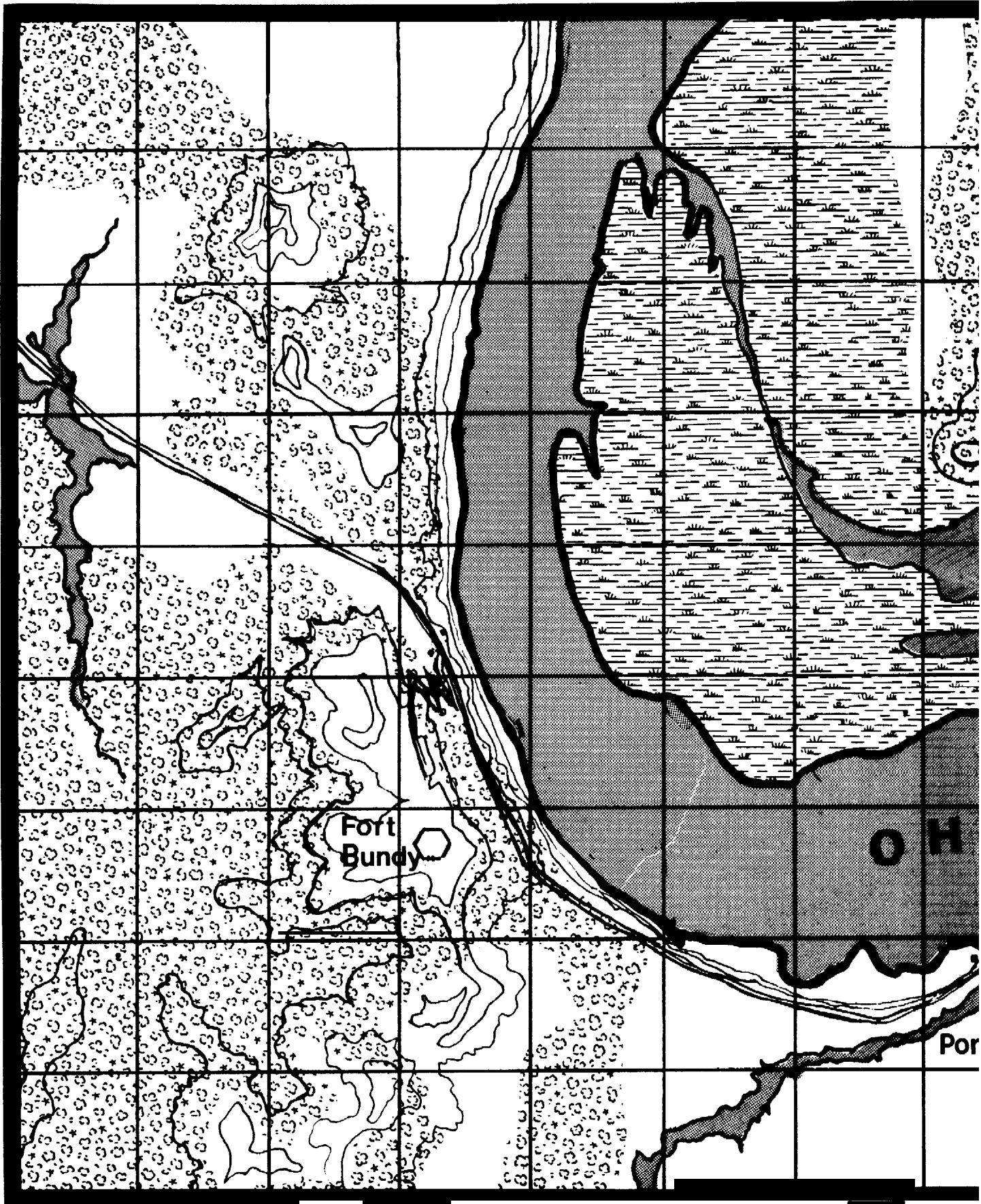

Contour Interval: 30M
Scale: 1 Square-1 Km

 Water

 Swamp

 Forest

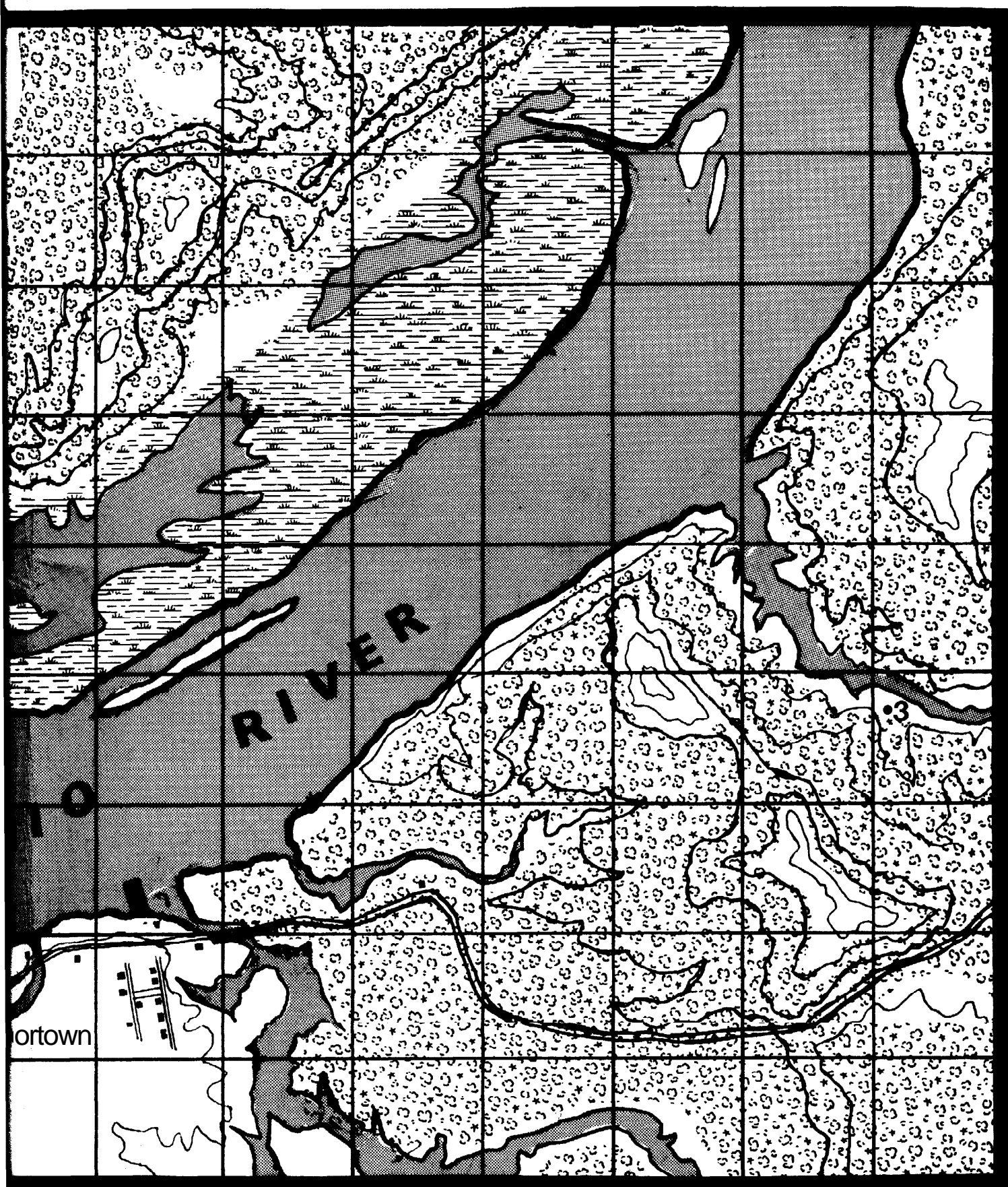

est  Dirt Road  Building  Supply Cache

BULLETS & BLUEGRASS

THE
MORROW
PROJECT
Project File 009



By Timothy J. McFadden & W.P. Worzel
Illustrations by L.A. Sobel

Playtesters: Brian Bunin, Matt Bunin, Jeff Rugert, Dan McCloury, Stan Markowski, Dave McFadden,
Robert Mani, Jeff Leslie, Brook Crawford, Hank Root, Michelle Peters and Ivan Ivansson

©Timeline Ltd. 1990

INTRODUCTION

MARS team K-98 will awaken to find themselves under attack, deep in hostile territory. Escape is possible, but the Science Team they were assigned to support has been captured. The Team must rapidly learn about the Kentucky Free State, how it works and what its goals are. They begin with a clear cut mission, but underestimating the enemy or overestimating him will certainly be lethal. Here, for the first time, the Project confronts an enemy who is as well armed as the team, well organized and much more numerous. Surprise and quick wits are their only advantage.

The Kentucky Free State has preserved much that was good from the 20th century, and all that was bad. Slave markets are held in the shadow of skyscrapers. Tremendous wealth is concentrated in the hands of a few, guarded by their army and the dreaded secret police. The enemy's goal is the preservation of their privileges and power. Their nightmare is an awakened and avenging Morrow Project liberating their vast population of serfs and slaves.

I. Situation: Pre-War

Kentucky was a center of coal mining and agriculture. Oil, limestone and natural gas existed in significant quantities, while extensive trade went on along the Ohio river, bringing much revenue into the state. Fort Knox, the training center for US Armored Forces processed thousands of soldiers for the army every year, while Fort Campbell on the Tennessee border was a major center for US Army Airborne operations. Roth forts brought a lot of revenue into the state. Kentucky was also famous for bourbon, bluegrass and horses.

II. Situation: The War

The Louisville-Fort Knox-Lexington area caught a mixed bag of nuclear and biowar strikes and was badly hammered in the War. Refugees fleeing the fallout spread plagues throughout the state. Decimated by a trio of nuclear strikes, Fort Knox was little help. Fort Campbell was the center of an attempt to impose martial law, fighting against local power-seekers and rioting. Its strength sapped by plagues and the desertion of men seeking to protect their families, its death knell occurred when a cabal of local leaders and ambitious junior officers attempted to set up their own regime. From then on, fighting between various factions raged on into the spring as plague and fallout devastated both sides.

III. Situation: Post-War

Fighting raged for years, as long as there were sides to fight. Most people simply banded together in their isolated valleys and towns, dug in and grimly held on. Ten years after the War, fewer than 40,000 people

lived in all of Kentucky, while broken and abandoned weapons littered the countryside.

MARS TEAM K-98

I. General

This Team had two missions. One: security for Science Team K-97. Two: responding to distress calls from MP units and their allies along the Ohio River.

The Team knows that the Science team has a Science One vehicle and a nine person team. The Science Team leader and the MARS team leader know each other and where their respective boltholes are. The MARS team leader knows the lockout code of the Science One vehicle (see below). The MARS team leader is the tactical commander, the Science Team leader is the group overall commander.

II. Personnel

K-98 has eight members. The members of the Team are all familiar with one another having lived through MP training together. All Team members are completely familiar with standard Project equipment and its operation.

Recommended loads for this module are 1,2,3,4,6 and 11. As usual, all Team members can operate one another's equipment though how well they do so may vary.

III. Team Equipment

The Bolthole

This is a standard Morrow Project bolthole mentioned in the gamebook and described in detail in **PF-01, Liberation At Riverton**. The size depends on the number of people in it and the size of the vehicle.

The Team's personal gear is in perfect condition. All weapons, including vehicle mounted weapons, were stored in cosmoline, a preservative grease. A 55 gallon drum of solvent is included in team stores. All munitions, supplies and ammunition are in sealed containers. Personal items, web gear, medkits, backpacks, etc., are stored in lockers beneath the cryotubes, except for issued weapons which are, again, stored in cosmoline.

Team Vehicles and Special Equipment

The primary MPV for this module is the SK-5 Hovercraft. The plan was that with the SK-5 the Team could successfully interdict movement on the river and they could quickly get to a troublespot. It was expected that once they arrived in an area where there was trouble they would dismount and deal the situation on foot. The Morrow planners had a keen appreciation for the flexibility of shoe leather for dealing with situations.

Thus, though the SK-5 is extremely fast, it is limited to the river bottom areas as the trees and

slopes leading out of the river valleys prevent travel beyond the floodplain areas. This was understood and expected. A team which tries to use the Hovercraft as a "flying tank" will be quickly disappointed and/or will turn the thing over in trying. For a complete discussion of the limitations of Hovercraft, see PF-06, Operation Lonestar.

In brief, air-cushion vehicles (commonly know as Hovercraft) are not flying carpets. They cannot "fly" and must have something to push against in order to lift. As a result, they cannot "jump over" gaps, and cannot climb inclines greater than 1-in-8 steepness; any grade steeper than this will tend to cause the SK-5 to flip over. Why? Because the fans actually begin to push the vehicle head-over-heels when it gets too steep.

Likewise, Hovercraft need a flat surface such as water, swamp or sand to hover on. They cannot "bounce over" rocky surfaces and any obstruction which is more than 2 feet high is a barrier to travel.

Hovercraft are also susceptible to being pushed around by winds. If a thunderstorm blows up while the Team is on the river, they will quickly find that the SK-5 is hard to maneuver and may tend to get blown onto shore, rocks, cliff faces, other boats, etc. A smart team will land the craft and lash it down before the storm hits.

In terms of the module, all this means that the Team will have difficulty getting the SK-5 up to Fort Bundy. The only realistic approach is up the road which climbs the north cliff face and even then, unless they go very, very slowly, they are likely to flip the SK-5 as the road goes up 300 feet in little over 1/4 of a mile, a 1-in-4 grade. The only reason travelling it is even possible is because of the carefully graded switchbacks which reduce the grade to 1:8.

Of course, travelling slowly up this road after first passing beneath the Fort's guns to get to it will attract a lot of attention. The Fort's defenders are not stupid. They know that the Free State does not have such vehicles and that the Morrow Project does. They will open fire as soon as the SK-5 gets within range and they have the firepower to do it in long before the Team gets to the gates.

Given that a MARS team is expected to fight, each Team member was also provided with a kevlar vest (Armor Factor=14, covers all four torso areas) and a kevlar helmet (Armor=10, 40% coverage of head from the front, 65% from the side and rear) The Team is also provided with two cases of NICO thunderflash grenades for hostage situations (see New Equipment section). These are intended for use during rescue missions.

One member of the team was also issued an MP Demolitions Kit. The M183 Demolition charge was a useful tool, but it was felt that combat oriented teams such as MARS and some Recon teams would need a more controlled demolitions ability. The combat

demolitions kit contains crimping pliers for blasting caps, tools, a wire cutter and the following tools:

- 10 M1 Timer Detonators
- 2 coils M700 time fuses
- 40 M7 blasting caps
- 40 electrical blasting caps
- 24 M60 fuse igniters
- 2 electrical blasting cape
- 200 meter coil of insulated wire for the electrical caps and detonators
- 10 radio controlled priming assemblies (require the insertion of electrical blasting caps)
- 1 radio control detonator, range: 3.5 km

The radio control detonator transmits two signals, an arming signal and a detonation signal. Each is broadcast on a different frequency. The detonation signal must be given within 20 seconds of the arming signal or the device disarms and the sequence must be repeated to detonate the assembly. This prevents random radio signals from setting off the device at inconvenient times - such as when they are being placed! Each RC priming assembly must be manually primed and loaded with a blasting cap.

Team Caches

The Team was supposed to be on call for emergencies all along the Ohio River. For this reason, its caches were more widely scattered than usual. Each cache was situated 1 to 5 kilometers up tributaries of the Ohio so as to be accessible to the team while being out of the river's floodplain. Caches were situated to be safe from erosion, but that was on a scale of three to five years. It is a tribute to the planners of the project that only two caches (#2 and #5) were washed away in 150 years of erosion.

Caches were heavy on ammunition and were much larger than normal MP supply caches, keeping in mind the prodigious ammunition requirements of the SK-5. Caches #3 and #5 were half the size of a standard MP bolthole. This was a MARS team, expected to respond to armed threats and supplied accordingly. Specialized weapons loads like the Stinger missile were placed in some of the caches, though Team members were expected to take general purpose loads for day-today use.

RDF

In each cache are:

- 8 cases 7.62 NATO
- 4 cases 20mm HEI
- 3 cases 20mm API
- 6 cases 12.7mm ball
- 4 cases M381 40mm HE
- 1 case 5.56mm (linked)
- 2 MP ration packs
- 1 SK-5 repair kit including:
 - 4 spare fan blades
 - 5 air cushion panels
 - 5 lexan window sections
 - 2 sets of steering vanes

In addition, specific items were included in certain caches.

Cache #1

- 1 case 9mm ball
- 1 case 40mm HEDP
- MP Dragon individual load (IBL)
- 1 case M18A1 Claymores
- 2 sets MP resistweave coveralls
- 2 sets boots
- 1 case M183 demolition charges
- 6 LAWs
- PRC-70
- 1 surgical kit
- 1 drug kit
- AN PAS-7 Viewer
- M85 Spares
- 1 General Purpose Toolkit

Cache #3

- 1 case M576E2 40mm "Buckshot"
- 1 case M26 grenades
- 1 case MK3A2 grenades
- 1 case M18A1 Claymores
- 2 AN-PRC 68s
- 1 M79 grenade launcher
- Instrument Spares for:
 - Radar
 - Auto-nav
 - Piloting instruments
 - Fire control equipment

- 1 Electronic Toolkit
- M174 spare parts

Cache #4

- 1 case M651 40mm CS
- 1 case 40mm "stunbag"
- 1 case NICO's
- 1 case 12g. 00 magnum buckshot
- 81 mm mortar with 20 cases M374A2 HE
 - 5 cases M375A4 White Phosphorus
 - 5 cases M301A3 Illumination rounds
- 2 M7A1 protective masks with spare filters
- 2 M1 CBR kits
- 1 MP trade pack
- Rh202 20mm Cannon spares
- 1 General Purpose Toolkit

Cache #6

- 2 cases 00 magnum buckshot, 12g.
- 1 case 40mm HEDP
- 1 case .357 magnum
- 1 case M583 40mm
- 1 case 9mm parabellum
- 1 case M18A1 claymores
- 1 case NICO's
- 1 case M7 blasting caps
- AN-PPS 5
- M9823 Starlight scope
- 4 sets boots
- 2 sets resistweave coveralls
- 1 Stinger Individual Basic Load
- 1 case C4 explosive
- 1 case M700 time fuses

Weather

Kentucky and the other border states have a mix of weather which can make them singularly unpleasant. The summers are often hot and muggy with storms travelling up the Ohio River Valley bringing rain, thunderstorms and floods with them. In the winter, these same storms are usually cold rain mixed with sleet and can even turn to snow. This makes life a misery and travelling actively dangerous.

The Team will wake up in midsummer to the usual hot, heavy weather which precedes a thunderstorm. The temperature will reach the 90°+ range during the daytime with 90%+ humidity. At mid-afternoon of the second day a driving thunderstorm will

begin with driving rains following that last for the next three days. This will turn roads to mud and swell the streams and rivers, bringing fresh logs and debris into their waterbeds which may cause the Team some difficulty. Travel on foot will be a miserable slog and getting a fire to light or stay lit will be a challenge that somehow didn't get into the recruiting literature.

The land is flat and swampy in the immediate vicinity of the Ohio River and its tributaries and hilly elsewhere. The hills are a series of hollows and ledges that make travelling a challenge, particularly with the Team's vehicle. Except for by the lowlands, the land is heavily forested making travel overland even more difficult.

THE PEOPLE OF THE LAND

The Kentucky Free State

The people of the Kentucky Free State are hardworking, generous with what little they have and uniformly poor. Literacy hovers around the 15% mark. They work hard, and wring what little humor they can from life. They band together to pull each other through in times of fire and flood and everyone responds on the rare occasion the militia is called up.

Their greatest fear is change, because most changes they have seen in their lives have been for the worse. Strangers suggesting change are expected to be from the Secret Police which they live in constant fear of as they live in fear of any of the Five Families. The lucky ones are the freeholders and independent shopowners, but there are fewer of these every year. The Five and their agents, the families of the Old Two Thousand, squeeze more on the independents every

year. Most common people are sharecroppers, laborers or miners.

The Old Two Thousand are the descendents of various employees of the Rich Five who served as their original rank-and-file. They fill the role of petty nobility and entrepreneurs, with the wealth of some of their families approaching that of the Five themselves. Each has a patron family and through them, a patron Administrator. This is the managerial class, in which literacy is universal and almost all have gone to the great university at Bowling Green. The Army and Secret Police draw most of their officer corps from this group. So does the Resistance. If there is a group the MP team can actively work with, it will come from this section of the populace, the hard working middle class of the Free State.

At opposite ends of the spectrum are the slaves and the Five Families. Both groups are not people you encounter every day in the Free State. The people of the Five Families make up less than 1/2 of 1% of the population of the Free State, control almost everything and have wealth that is unimaginable to the average human being of the 22nd century.

Slaves make up a growing 15% of the population, control nothing, get the worst jobs and live in squalor that is all too common for human beings of any century. A few lucky house slaves are the exceptions. It is worth noting that the Free State is egalitarian about their slavery. They will enslave someone regardless of race, creed, color or sexual preference. Brought up with a firm conviction of their own superiority, the people of the Five Families tend to be educated, supercilious and callous to the problems of the lesser classes.

The Growth Of The Kentucky Free State

The Rich Five didn't start out intending to be dictators. It just sort of happened.

When the five industrial leaders of what eventually became the Rich Five made their plans, they had no intention of trying to restore order out of chaos. They intended to preserve themselves, their friends and their wealth in order to go on living as they had been living. Provision was made, secretly, to keep 2000 people in cryosleep for ten years. They did not expect to awaken to an unchanged America. Some looked forward to a chaotic, wild-west style future with no all-pervading government looking over their shoulder. In their massive, hidden mountain complex in Kentucky, they stockpiled food, medicine, weapons for self-defense, precious metals for trade and most vital of all, information. Secure in their plans, those who made it to their complex as the bombs fell went into cryosleep.

They awoke to chaos. Kentucky, never a rich area, had been nearly depopulated. The remains of several factions struggled over the little that was left using the last of the weapons from Fort Knox and Fort Campbell. Hunger, disease and war stalked the hills.



In the savage struggle that followed, the organization of the five industrialists was the only organized, well-equipped group. Not surprisingly, they won, though not before a lot of blood was shed. Using their technical facilities, some captured equipment from Fort Knox and their knowledge of military organization they welded together an army which was more like a modern army than anything they were fighting.

Once the immediate fighting was over, the process of rebuilding began. Over the next twenty years "The Old Two Thousand," led by "The Rich Five" took on the task of rebuilding civilization. Refugees came seeking protection from the chaos outside. Surviving technicians were incorporated in the new order and its industries. Others became farmers and miners. Prisoners of war and criminals became convict labor. The population grew and kept growing. Few really cared that everything that was built seemed to belong to the Five. The Army guarded the borders and fought and fought again.

Forty years after the War, the Kentucky Free State was named. It was free only in the sense that it was free from the chaos that was the rule elsewhere. In the desperation of the times there was no room for the niceties of democracy, the order of free trade, the luxury of learning. The Five, as practical men, ruled over a population that was always just a step away from famine.

As time passed and one generation succeeded the next, what had been a matter of expedience became a matter of policy. The Army became an established entity, the Five become absolute rulers, the Two Thousands their technical elite and the rest commoners, serfs, and slaves.

Economically the Free State began trading along the Ohio River. They bought steel, pieces of old technology, books furs, raw cotton, wool and slaves. They sold medicine, woven cotton cloth, trade rifles, percussion caps, tools, paper, horse drawn agricultural equipment and dozens of other items. What they did not sell were modern firearms or ammunition, engines or information.

They would trade ten "Trade Rifles" (as the percussion cap rifles became known) for one modern firearm in working condition. It wasn't that they needed them (after all, they could manufacture them), but they wanted to get modern weapons out of the hands of people they might need to fight or might want to conquer. And since the technology to produce percussion caps was not generally available outside (but see **PF-05, The Starnaman Incident** and the Barlow rifle), the people they traded with were dependent on the Free State.

At home, wealth remained concentrated in the upper society of the Five. Common workers earned little more than subsistence wages. Employers didn't have to worry about markets and consumers at home when

they could sell their goods along the rivers. Wood-fired steam engines carried commerce within the Free State as the railroads were restored.

Fusion power plants were installed as the scientists of the Free State were able to "reverse engineer" the Morrow fusion plants discovered with buried teams. Prior to the "discovery" of fusion, coal-powered plants were in widespread usage so the infrastructure to support power production and distribution were already in place.

Fusion also allowed the Free State to turn garbage and coal into petrochemicals for their industry so such 20th century products as plastics, drugs, dyes and insecticides are in use in the Free State.

Industry advanced to the point where small towns could pool their resources and buy such things as a communal radio set or even (occasionally) a television set which they could use to pick up the broadcasts from the bigger cities.

The mountain fastness the Five had slept in was a secure base and a starting point for their war against the savages that roamed Kentucky. But as a central capitol it was useless. Therefore 75 years ago the city of New Manhattan was founded near where Danville, Kentucky used to be. It was built to be a gleaming metropolis reminiscent of the cities of the lost 20th Century.

About the same time, the city of Louisville, which had fared badly during the War began to recover from the biostrikes which had destroyed it. Situated on the Ohio River, it again became a major center of trade. First pockets of the city were rebuilt, then more and more of it was cleared and reestablished until today it is once more a thriving center of trade along the Ohio.

The Free State Today

The northernmost portion of the Free State is the bend of the Ohio river just south of Cincinnati. The Free State's eastern border is the Appalachian Mountains, much as it was 300 years earlier. The southern border skirts around the remains of Knoxville and follows the Tennessee River as it turns west and then north until it empties into the Ohio. None of the dams on either the Ohio or the Cumberland still exist and they have returned to their pristine state prior to the Tennessee Valley Authority (circa 1935).

Bowling Green and its University are the center of education and research in the Free State. Not incidentally, they are also the center of dissent and revolutionary activity. Students from all over the Free State and from numerous towns up and down the rivers to attend Rockfall University (as it is now called). A substantial majority of the EmDees in this part of the country are trained here. Towns in the Free State often pool their money to send promising students here. This busy college town has grown to 30,000 people since the War. The Sixth Regiment (Praetorians) are based



outside of this town as well as one of the three squadrons of the air force.

Louisville today has a population of over a hundred thousand people and it is the largest city in the Free State. It is also the Free State's industrial heart and the base of its river trade. In this city are traders from up and down the River and its mills and factories take in all they bring. This city arms the Free State and in its riverfront taverns boatmen and fur traders rub shoulders with farmers and factory workers. It is said that if you can't buy a thing in Louisville, it ain't worth buying.

The political center of the Free State and its real heart is New Manhattan which was built where Danville, Kentucky used to be. Thirty thousand people live here. The Five designed this city to be a gleaming metropolis of skyscrapers and have gone a long way towards that goal. Note that their capitol was named after Manhattan rather than Washington. The Seventh Regiment are headquartered outside this city. With its broad, well-lit avenues, its tall buildings and its fantastic wealth (in Post-War terms), it may remind MP characters of the lost past. But there are jarring dissimilarities - New York never had open slave markets between the skyscrapers.

Despite the relatively advanced level of technology, the Free State is, for the most part, a technologically and economically stagnant society. There is no mass

production of consumer goods and things like TV and radio are strictly luxury items. Innovation is acceptable but not encouraged. Life for the common folk is hard, reasonably secure and tolerable as long as they mind the rules. No one ever forgets that the mines always need more slaves. The Old Two Thousand are well off and are usually managers and (to a limited extent), entrepreneurs.

The families of the Rich Five live in guaranteed comfort with cars, planes, mansions and racing boats. Many occupy themselves with the aristocratic pleasures of horse racing, fox hunting, dancing and banquets. Other enjoy the constant political intrigues among the families as they struggle to control the SP, the army and the Free State itself. Each family has a small army of bodyguards and assassination, while not common, is not unknown.

Slavery

Slavery is so common throughout human history that its occurrence is almost more usual than not. A slave society is not only a moral abomination, but it is economically uncompetitive. Slaves provide a cheap labor force which has no unions, no wage committees and no say in how things are run. They even produce more slaves.

But societies based on slavery are inefficient. There is no incentive for a slave to work more efficiently or to

produce better quality work. But since they are effectively a fixed-cost item, they can out-compete (in the short term) non-slave enterprises.

Worse, they destroy respect for human life, families and the intrinsic value of the human soul. Since slaves are an easy answer to the difficult problems of bad or dangerous working conditions, since more can be added as needed to replace casualties and since they have no say in when, how or where they are used, all labor becomes suspect and compared to slave labor. The notion of a day's wages for a day's work is a casualty to the slavery as is craftsmanship, the value of human life and the notion that "All men are created equal."

The Free State has fallen prey to slavery. Originally a stopgap solution of convict labor when labor was scarce, it evolved into an accepted institution which came to form the basis of labor in the Free State.

And on the flip side of the coin, the free, particularly among the Five Families, spend a lot of time justifying slavery. "It is Just that those who fail become slaves, this is the way of nature." "Slaves are intrinsically different (and inferior) from us." and pragmatically, "Without slaves, production would grind to a halt." These are the rallying cries of the new apologists who have sprung up in the Free State. And to enforce their will, the Secret Police were created.

Race has nothing to do with slavery in the Free



State. Slavery is more on the Roman model: Convicts, prisoners of war and debtors become slaves owned by individuals or the great industrial combines. They are usually given the hardest and most dangerous jobs - deep mining, chemical waste disposal, etc. Attrition is therefore high but the threat of such assignment keeps slaves in line and slavers keep the Free State well supplied with fresh stock.

Luckier slaves become house servants or in some cases, even teachers. For some wars, Janissary units of slaves armed with Trade rifles are formed with the promise of manumission for survivors. Unfortunately for them the Army tends to regard such units as expendable cannon fodder so few survive to get their reward.

It is theoretically possible for slaves to buy themselves out of slavery but in practice this almost never happens. For most, slavery is a one-way ticket to a short and miserable life. The only exception is if a family member of a debtor can come up with the money to rescue the debtor before he or she is sold outside of the area they lived in. This begets the grisly sight of family members bidding for their loved ones as they stand, naked, on the auction block.

Slavery is well established within the Free State. Most slaves who were born to it accept it as what life is all about. So do the Rich Five. It is only a few wild-eyed intellectuals who question slavery. Attempts to free slaves often lead to slaves turning themselves (and often their would-be rescuers) in to the authorities.

Few within the Free State can imagine how life could go on in the same way without slaves. This is indeed the case. The Free State, as it currently exists, could not continue without slavery.

Gladiatorial combat between slaves using archaic weapons has recently become popular and there are members in each of the Five Families who sponsor games which are televised.

The Army of The Free State

The Army of the Free State was assembled from fragments of the US Army detachments, local militia, company security and local police departments taken over by the Free State. However, it has been well over a hundred years since this force has had to fight anything even remotely resembling a war. Fighting starving bands of border raiders and river pirates or suppressing the odd slave revolt has given it an exaggerated view of its own prowess. Further, a century of peace has permitted many bad habits to become tradition.

The overall idea of the army is something similar to the British army before World War I. Regiments are raised from the populace of a county. Enlisted men are highly disciplined and well trained. Corporals and sergeants are chosen by merit and tend to be

ferociously competent. Officers are selected from the 'right' families and are promoted through political connections. The quality of officers ranges from brilliant to abysmal, but tends toward the lower end of the spectrum except in those cases where the military is an honored tradition.

The standard rifle of the Army of the Free State is the Ruger Mini-14 modified for military use. This was used as a prototype because of original stocks from before the War. It is now produced with a bayonet lug, flash suppressor and rifle grenade launcher and can fire on full-automatic. Soldiers are usually issued five 40 round magazines. The rifle fires standard 5.56mm ball ammunition. The army crew-served weapon is the CETME, a Spanish modification of the old German MG-42 chambered in 5.56 as well.

Both of these weapons are reliable and simple weapons made to the highest standards. The rifle grenades issued to some troops are of the "bullet catcher" variety and require no special ammunition or modification to the rifle. Full statistics on these are in the New Equipment section of the module.

The standard army sidearm worn by officers is the Smith and Wesson Model 59 pistol. The grenades the army uses are exactly the same as standard M26 fragmentation grenades and M34 white phosphorous grenades as described in **GB-1, The Morrow Project Gamebook**. CS Grenades are occasionally issued for crowd suppression and such like.

The cavalry units mentioned below primarily use the M2 "Bradley" APC as described in **PF-06, Operation Lonestar**. Likewise armor units use the M1 "Abrams" main battle tank (also in **Lonestar**). These vehicles were selected by the Army of the Free State because of the available prototypes from Fort Knox. In both cases these were originally the most plentiful type of unit available after the War.

Later, when the Free State began to manufacture their own armored units, they stuck with these basic designs but with some significant differences. Both the M1 and the M2 are sophisticated combat vehicles. There are many things from the M1's gas turbine to the transmissions that the Free State simply couldn't reproduce. But they had the patterns in the form of the existing vehicles so they modified them in such a fashion that their industry could handle production.

For example, the M1 has much thinner armor - about half a meter at best - and much lower quality (no composite armor). The rounds for the M1 are limited to solid shot. There are no TOWs for the M2s. Neither vehicle has a stabilized gun platform or laser rangefinders.

Thus, while still formidable, they are not the same vehicles as produced for use in NATO.

The smallest unit in the Army is the squad. Seven men are in each squad, four with Mini-14s and hand grenades, one with a CETME and four 150 round

boxes of ammunition and two grenadiers who carry three magazines and eight rifle-grenades a piece.

Four squads, two led by corporals, two led by buck sergeants make up a platoon with one lieutenant as a platoon leader and one platoon sergeant to run the show.

Four rifle platoons, one headquarters platoon and a weapons platoon make up a company. Commanded by a Major with a Captain as a second in command, a company of troops has roughly 180 men. The weapons platoon will have four heavy weapons. They typically have two .50 cal M2 Brownings and two 81 mm mortars. Weapons may vary according to local requirements.

Four rifle companies, one headquarters company, one artillery company with sixteen 105mm cannon and one troop of cavalry equipped with sixteen V-300s form a Regiment. Such a unit can field just under 1300 men. All Army and Air Force vehicles use multifuel rotary engines capable of running on virtually any flammable liquid as, despite the availability of fusion technology, the Free State does not yet have the industrial capacity to mass produce small units for use in vehicles.

There are seven regiments in the Army of the Free State. A company or cavalry troop is commanded by a Major, a Regiment by a Colonel and two one-star generals lead the Army, one as General of the Army, the other as Armed Forces Chief of Staff.

The Sixth and Seventh Regiments are nicknamed "The Praetorians." Their four line companies are equipped with four tanks and two M2 Bradleys APC per platoon, eighteen tanks per company, seventy-two tanks to a Regiment. These regiments have eight men per squad and two extra companies of infantry mounted in more Bradleys. The Sixth and Seventh Regiments can each field 1600 men, 72 tanks and 84 Bradleys each. The Seventh Regiment uses M60A3 tanks fitted with the same armor used on the M1. The Sixth uses M1s. Both Regiments are paraded often while all families constantly vie to control them as either Regiment could take on any three other regiments and win. Command of the Seventh Regiment, as a Colonel, is known to be the final step before promotion to General of the Army while the Sixths commanders usually become Army Chief of Staff.

Recruits are trained at the base outside New Manhattan, which is what the two assigned rifle companies there are for. The best recruits go to the tanks. All soldiers are taught to use all infantry weapons as well as being put in top physical and mental condition. Enlisted men sign up for six years and may not marry. If a soldier reenlists, he may elect to serve two, four or six years. Promotion does not depend entirely on seniority but it is a factor. Corporals or above may marry, but only officers have family quarters provided. Families are not permitted at border posts. Instead they live at cities in the interior, both for their

safety and so the SP men can keep use them as potential hostages.

Pay is thirty credits a month, forty for a corporal, fifty for a buck sergeant and so on, up to a First Sergeant who makes the princely sum of one hundred credits a month. The average civilian laborer sees forty-five credits a month in pay. With his day-to-day needs of food, clothing and shelter taken care of by the army, this makes even the lowest private fairly well off by the living standards of the Free State. This is a powerful recruiting inducement and is one reason that the army can pick and choose its recruits carefully. Uniforms are olive drab with rank sewn on the right sleeve using standard US Army rank circa 1955. Each soldier is issued three cotton summer uniforms, two wool winter uniforms, LBE, entrenching tool, messkit, bayonet, poncho, two pairs of boots, one campaign hat and one steel helmet. The helmets are stamped steel and are of the "coal scuttle" variety used by the German Army of World War I and II. They are Armor Factor 4.

The Free State can manufacture both resistweave and kevlar, but the cost is too great for them to issue it to common soldiers. Officers and senior NCOs often purchase resistweave camouflage uniforms and kevlar vests along with kevlar thigh pads that fit into the front pockets of the resistweave uniforms. The vests made by the Free State are slightly inferior to modern kevlar and so are only Armor Factor 12. The thigh pads are Armor Factor 10. An officer's family will often buy him a full set of body armor when he joins the army.

Officers usually carry folding stock Mini-14s and sidearms. Campaign hats are worn everywhere by all ranks except in combat.

The Air Force

Few working aircraft survived the days of chaos. What few did were used by the Free State until they literally fell apart (sometimes in mid-air). But having planes was useful and so the Free State looked for a design of proven ruggedness and utility. Originally they intended to build jet fighters, but two factors stopped this. First, none of their neighbors, indeed, no one else in the world as far as they knew, had jet aircraft.

Second, the technical problems of manufacturing jet engines were deemed too great. Instead, the Free State duplicated the P-47 Thunderbolt, a piston driven fighter that they happened to have a prototype of care of the Confederate Air Force. The P-47 was used extensively during the Second World War. Nicknamed the Thunderbolt, it was a rugged design carrying eight .50 caliber machineguns as well as being capable of carrying a tremendous bomb load. For the air support missions the Army needed, it was perfect. Six squadrons of eight aircraft apiece were formed.

Since then, aircraft have been manufactured on a one-for-one basis to replace losses. A few planes have been declared "surplus" so that they can be purchased

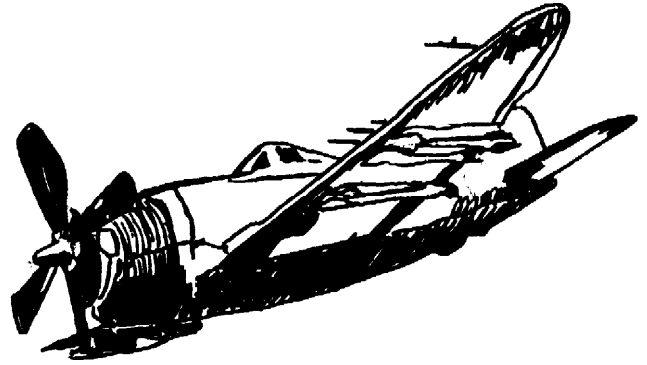

by wealthy members of the Five. Such planes are declared surplus while still fresh from the factory. Other light aircraft are occasionally custom built for the wealthy.

The Air Force is a "status" service and pilots are chosen from the best families. All pilots are at least of the "Old Two Thousand" stock. Peasant born pilots are unheard of. This has a detrimental effect on the quality of pilots in the Air Force since many marginal pilots stay in due to their political connections. Further, the flyboys tend to have a callous attitude towards the army soldiers they are called on to support and tend to be somewhat careless as to where they dump their ordnance. This makes the normal soldier reluctant to call in an airstrike under any but the most desperate situations.

There are three Air Force bases in the Free State, each of which has two squadrons of P-47s. Each squadron has two companies of troops assigned to it, one of maintenance personnel, one for defense troops. These troops are responsible for defense of the air fields. Each squadron is commanded by a Major. Two of the air bases are commanded by Colonels while the third, outside New Manhattan, is commanded by the General of the Air Force.

Enlisted uniforms are grey. Headgear is a black baseball cap. Officers wear peaked caps and blue uniforms with a simple white stripe sewn onto the outer leg of the trousers.

The Secret Police (SP)

Growing out of the original security forces hired by the Five, the Secret Police acted as Military Police during the days of chaos. As the Free State became a political unit, it needed an intelligence arm. The security squads happily became both intelligence units and goon squads to enforce "harmony" among the population of the Free State.

In recent years they have also taken on the task of locating and neutralizing any MP teams they locate

inside the Free State or its near vicinity. The leaders of the Free State have not specifically ordered this, but have implicitly approved it. If an intact Morrow Project organization ever appears, they can disassociate themselves from the actions of the SP, until then, it is the opinion of the Five that these heavily armed MP teams can't be permitted to wander around the neighborhood, particularly since they harbor ridiculous prejudices against slavery, dictatorship and the normal course of business.

In their mountain fortress near Harlan, Kentucky, they have computers which they use to track all information they have about the Morrow Project. Hints, rumors, the results of interrogations of the few MP personnel unlucky enough to fall into their hands, all are included into this database. Where possible, they have extrapolated likely locations for teams and keep watch for new sightings.

If an awake and active MP team is spotted, or if the exact location of a buried team is discovered, a Special Action Unit is put together to "neutralize" the team and capture its equipment. These units are never more than platoon in strength but they have Air Force units on call.

The SP seeks to infiltrate all aspects of life. No one is beyond their reach and anyone who poses a threat (particularly to their own existence) is an enemy. They have their own air assets, V-300s and a small collection of Morrow Project vehicles. Ambitious people from all walks of life are accepted into their ranks so long as they follow the rules. This is one of the few places where commoners can rise to power within the Free State.

Within their own ranks, the SP considers themselves the elite of the military and subject to no rules or laws. They treat the general corruption in the Free State with scorn and it is said that the files they keep give them power over the very highest levels of the Council of Five.

Their uniform (when they wear one) is black cotton fatigues with a black beret (thus the nickname of "Blackshirts"). Armament is a matter of personal choice. Special Action Units wear captured MP resistweave uniforms dyed black or camouflage resistweave with black berets. They also wear kevlar vests and are issued photo ID similar to that of law enforcement personnel and officer and senior NCOs in the armed forces.

Law Enforcement In The Free State

The courts of the Free State appoint one sheriff per town who chooses as many deputies as he believes he needs. The Sheriff is responsible for enforcing the laws of the Free State as he sees fit, subject to review by the Judge who appointed him. In the normal course of things a Sheriff can only be removed by the Judge who appointed him.

If this sounds like a formula tailor made for corruption, that's because it is. Sheriffs and deputies are expected to be corrupt, as are judges. Such offices are routinely bought and sold. The extent of such things is expected to be kept within reasonable limits, but Sheriffs and Judges always retire with a comfortable nest egg and as long as order is kept, the Powers in New Manhattan don't much mind what happens. The only compensation in this system is that it has eliminated lawyers. The concept of justice in the Free State is not so much ignored as assaulted.

Sheriffs carry Smith & Wesson Model 59s as sidearms and are authorized to equip their departments as they see fit. Deputies carry a variety of sidearms, shotguns and rifles. A typical Sheriff's department has five men, two Mini-14s, and three Remington 870 pump shotguns with magazine extensions allowing them to hold 8 rounds in their tubular magazines. Sheriffs are also responsible for raising and training town militias in times of "civil disturbance or invasion." Such functions are fairly frequent in border towns, as raiders from outside occasionally make quick looting raids on the Free State. In the interior, this rule is only used as an excuse for a lynch mob.

Weapons In The Free State

Gun control in the Free State is a serious matter. Licenses are required to own any weapon more sophisticated than a flintlock or cap-and-ball muzzle loading rifle or pistol. Only the wealthiest of the Old Two Thousand can afford brass cartridge firearms, though it is taken as a matter of course that a member of the Five families can own and carry any weapon he or she pleases. At one time, the Free State attempted to take away even the primitive firearms that the common people were permitted to have. Cross-border raiders were then able to raid with impunity, destroying entire towns before Army units could show up. So much damage was done that primitive firearms were made legal for the commoners.

The Free State has gunsmiths in all of its major cities and towns and working replicas of almost every firearm made and used in the 20th century can be bought from the master craftsman, but only in very small quantities and only with the correct permits, signatures, reasons for owning, etc., etc.

The Underground

Any dictatorship as corrupt as the Free State is creates resistance. Some citizens of the Free State are unhappy with the corruption of the society around them and its many injustices. Many would-be power seekers, frustrated by the grip the Five have on all political power join them.

As a result, numerous mutually antagonistic underground organizations have emerged, ranging

from Friday night debating societies to full-fledged resistance groups with weapons stockpiles, safe houses and military operatives. Despite the savage efforts of the SP, these organizations continue to grow though many of them are riddled with SP spies.

These organizations have varying goals and attitudes toward the Morrow Project. Some will aid MP personnel while other will turn them over to the authorities.

The chief underground organizations are listed below.

The Spartans

Founded by ex-US Army personnel in the chaos years, the Spartans believe that the corrupt civilian government should be swept aside and replaced by an efficient military organization. Then a military state could be founded, the entire resources of the Free State could be harnessed and the great crusade for the reunification of the United States could be begun. Their dream is to recreate a republic with the Spartan virtues of universal military service, prowess in battle and personal courage.

Popular among junior officers and career military families, this is the toughest and strongest of the factions. Among this group are the best military minds the Free State has produced. Tough, hard and ruthless, they are the greatest threat to the Five that exists. Unfortunately, were they to succeed, they would build a military culture instead of restoring the democratic liberties of the United States. They regard other underground groups as hopelessly idealistic dreamers and are very suspicious of the Morrow Project.

MP personnel who can prove they were ex-military will impress any given Spartan who probably has an extremely idealized view of the old US military. MP personnel must show military competence if they are to keep that respect. The only virtues the Spartans respect are military ones.

The Children of Liberty

Originally founded as an anti-slavery group, these are now the most active foes of the government. Their basic philosophy is the old Jeffersonian ideal that "All men are created equal." Their goal is the reestablishment of the United States government and the Constitution and the overthrow of the Five and the abolishment of slavery.

Even these ideas are unheard of in the general population as the powers that be have made sure that what records there are of the time before the War omit any description of the government or the founding principles of the United States. Books which describe such things or which contain detailed histories of the 20th Century or earlier are contraband and being

caught with such a book is cause for arrest by the SP.

In recent years they have become much more professional as such Snake Eaters and MP personnel as have survived have put aside their differences and started working with the Children.

They have made guerilla raids to free slaves from the mines and have successfully rescued people from the tender mercies of the SP. They have also begun carefully thought out propaganda campaigns that has increased dissatisfaction with the corruption and inefficiencies of the Free State and have caused dissent even among The Two Thousand. Many Sheriffs and Judges are finding it more and more necessary to back their decisions with force of arms and this has caused trouble throughout the Free State.

What were once quiet, productive areas are now hotbeds of trouble. This has caused a similar increase in SP activity across the Free State which has fed the dissatisfaction.

The Children of Liberty have a network of safe houses across the Free State and a headquarters in the labyrinth of caves near Cave City, Kentucky. Several ex-Masons were among their founding members and member use a significant number of hand gestures, code phrases and small signs to pass messages.

The Children openly despise the Spartans and actively seeks to exterminate the Minutemen.

The Minutemen

A radical offshoot of the Children of Liberty, The Minutemen were organized to sow chaos within the Free State. Though very small in number, they seem impossible to exterminate. While it is hard to judge the political goals of the Minutemen, they seem to feel that the chaos engendered by their actions will somehow cause the downfall of the Five. If some innocent people get caught in the crossfire, that's too bad. If they were really innocent they wouldn't be cooperating with the authorities.

They consider the Spartans as Fascists (not too far wrong) and betray them to the SP whenever possible. There is an ongoing vendetta with the Children of Liberty and it is not unusual for a Minuteman assassin to lie in wait for members of the Children and to help them die at an early age from lead poisoning.

DOMINANT FIGURES IN THE FREE STATE

The Free State is led by five administrators, each of them the head of one of the Rich Five families. All have been raised from birth in tremendous wealth and power. They constantly vie with each other for power. All are absolutely dedicated to preserving the privileges of their families and any threat to those privileges will instantly unite them. All know something of the SP program concerning MP teams and wish to know no

more. Most of them fear to expand the Free State by conquest, not only because it would be a change in the status quo, but because they fear what a successful general returning from the conquests might do. Further, such conquest would be expensive and uneconomical.

Administrator Margaret Carswell

A small, straight-backed woman with a will of iron, she has grey hair going to white. A woman who has taken power in a man's world, she is the Matriarch of the Carswell family. She is totally ruthless and has turned more than one relative over to the SP for various reasons. Her family owns the great fusion powered oil cracking plants which convert coal and garbage to oil. Once a famous beauty who manipulated men with her looks, she now manipulates them with cunning, fear and sheer will.

Regarding the Morrow Project as a minor nuisance, she believes the SP could better use its strength against the Resistance. She carries a small 9mm pistol in her purse at all times and has used it more than once.

She thinks Trent Carswell is a jackass and is openly scornful of his "plans" for conquest.

Administrator Victor Wilson Getter The Fifth

Victor Getter retired from the Army with the rank of Colonel after commanding the Third Regiment in order to assume control of the family business. His family controls production of the military and civilian vehicles and other large industrial production.

His retirement from active military service was a relief to the men of the Third as he was one of the worst officers in an officer corps distinguished by lack of military skill. Not realizing this, Victor still regards himself as a soldier and wears his uniform to social functions.

A broad-shouldered man with blue eyes and grey hair, he is always armed, has a soft spot for any Third Regiment Trooper (his "boys") and is inordinately pleased when people refer to him as "The Colonel."

Administrator Madsen Wilson Kirby The Third

A tall, balding man with a pot belly, Kirby's family wealth is based on agriculture. Far from giving him any empathy with the people who live on the land, he has terrific contempt for peasants and farmers, regarding them as a resource to be squeezed for every spare credit. His methods have been responsible for a steady drop in agricultural production over the last ten years. His corps of assassins has silenced his most vocal critics are silent but have had no success in encouraging agricultural production.

He is very alarmed by the growing resistance from the countryside and advocates a pogrom to eliminate

dissent, replacing free farms and farmers with massive slave farms in the style of latia fundia.

He is also opposed to what he views as the unnecessary waste of money for high-tech goodies such as Bradleys, MIs and airplanes. Since no high-tech enemy has emerged in the last 100 years, he regards the entire Air Force as a waste of credits. For this reason he is against the SP's campaign against the Morrow Project or any plans of conquest as they could be the justification for continuing what he terms "military waste." He will publicly ridicule anyone who suggests TMP is anything more than a bunch of madmen.

Administrator Charles Henry "Chip" Hunter

An ex-Air Force pilot and the head of the Hunter Industrial Combine, this sandy-blond middle-aged man enjoys his life and his privileges. He has his own fully armed and equipped P-47 at his own private airfield as well as several other light planes. Business bores him but he takes to political intrigues with the same gusto he threw into flying. He still has the catlike reflexes of a fighter pilot and boasts that he can fly anything with wings. He regards his workers as cattle but observes that: "If you want to get milk from a cow, you gotta feed it first."

He supports Trent Carswell's idea of conquest as he rightly feels that the Free State has become stagnant. He also has ideas of getting in on the action of such a campaign.

Administrator/Judge Wilson J. Studebaker

A portly, white-haired man who dresses in conservative three-piece suits and carries a gold watch in his waistcoat pocket. He is known as The Judge by all and he is the chief justice of the Free State as well as chief patriarch of his family. His family owns the steamboats that carry trade up and down the River as well as the railroads that move all goods within the Free State.

He carefully cultivates the image of being dignified, prudent, wise, far-sighted, cultured and intelligent. He is also thoroughly evil, sadistic, venal, and ambitious. He regards himself as the true power of the Free State and he is not far wrong. The policy of letting the SP hunt down and exterminate the MP teams is his idea though nobody else realizes it. He perceives the Morrow Project as a minor threat to the Free State and thus to him, but he is carefully using the campaign to boost his control over the SP by setting up his rival's officers to fail while making sure his people succeed.

In his opinion, the Judiciary, the Studebaker family and the Free State are tools of his personal will. The current campaign by the Underground against Judges and Sheriffs is a personal affront and he is using Madsen Kirby as a foil to push the move against the



farmers in the countryside.

He has the largest personal fortune in the Free State thanks to extensive skimming and payoffs. He puts most of this money to use in his own network of informers. As a result he has a small but thorough personal library of blackmail information on anyone who is anyone in the Free State. He keeps this library with him at all times, filling one large briefcase of carefully typed notes.

He also has a plan to make it necessary to serve in the armed forces before you can attend the University. He reckons that having been shot at by members of the Underground will reduce the likelihood of students joining them.

General of the Army, Trent Carswell

The commander of the Army of the Free State, Trent Carswell is a big man gone to seed. He is a jovial backslapper, cheerful and increasingly fat. Though he commanded the Sixth Regiment for two years, he never actually got into one of his unit's tanks. He couldn't fit.

He is a conniver, and a legalist who believed in Rules and Regulations as created by God (in the person of himself). Surprisingly, he has an impressive reservoir of personal courage and distinguished himself in border fighting in his youth. His men actually like him and consider him a good-luck charm. His NCOs carried him through his fights as a youth and he has provided a handy figurehead since then. He passed up the opportunity to be Army Chief of Staff because he wanted to stay out in the field with "his boys."

He advocates expansion of the Free State, and does so vehemently and as often as anyone will listen. He has visions of being at the head of victorious "legions" conquering "barbarians" to the north, south, east and west. He has even gone so far as to offer part of his family fortune to finance such an expedition. While this is frowned on by his family (they are thinking of replacing him), it has caused The Five to consider military expeditions. Those for expansion figure that Carswell would be no threat as a conquering hero, those against figure it's a way to embarrass Carswell and the military as a whole. Both groups plan to use

this as a way to impoverish the Carswell family.

General of the Air Force Stanford Hunter

A tall, wiry man with sharply chiselled features and blue-black hair, he is seemingly just another swaggering sky pirate. He takes after his "Uncle Chip" Hunter in that his great passion is flying.

During one strike mission, his plane was knocked down by a violent storm and he spent six months with a tribe of Indians west of the Mississippi before he came back and he has never forgotten the experience. He has a greater appreciation for the life of the common man and is sympathetic of slaves though his first loyalty still remains to his family. He carries a bone-handled bowie knife as a reminder of his experiences.

He supports Trent Carswell's visions of conquest, but is loud about how the only use for the Army is "to move in after we've done the job for them."

MONEY IN THE FREE STATE

A complex economy needs a money to function. The Free State has a monetary system based on the Credit. All coins presently issued are of pure silver or gold. The One Credit coin is the size of a quarter and is made from pure silver. The twenty and forty credit coins are made of pure gold. The twenty credit is the size of a US nickel but thinner, the forty credit coin is the size of a US quarter.

Five and Ten Credit coins were originally issued but have fallen into disuse. Several smaller coins made of silver and copper are used and are still called quarters, dimes, nickels and pennies.

Gold, silver and jewelry from outside of the Free State are often brought in and as long as they are relatively pure can be traded for Free State currency.

In the last sixty years, paper money in a variety of denominations has come into use. The paper money is made to comparatively high standards (though not by 20th century standards) and is hard to counterfeit. There are predictably harsh penalties for counterfeiters involving enslavement to the mines that deter any but the most competent or the most foolhardy.

The average factory worker makes 45 Credits a month. The average farmer sees perhaps a hundred credits a year and is usually deeply in debt both to the local store and to his landlord. Still, fishing, hunting and the family garden plot mean that all but the poorest sharecroppers live better than their cousins in the cities.

Average Prices In The Free State

| | |
|--------------------------|--------------|
| Beer, glass | CR .10 |
| Whiskey, glass | CR .30 |
| 1 kg salt pork | CR .25 |
| 1 kg beans | CR .10 |
| 1 kg dried fish | CR .20 |
| 10 kg potatoes | CR .50 |
| 10 kg flour | CR .70 |
| A good meal | CR 2.00 |
| Deerskin, cured | CR .85 |
| 1 kg cured tobacco | CR 2.00 |
| 1 cured giant mink | CR 20.00 |
| Kerosene lantern | CR 3.00 |
| Work Shoes | CR 2.00 |
| Pair jeans | CR 1.00 |
| Cotton shirt | CR .75 |
| 1x1 m cotton cloth | CR .25 |
| Wool Coat | CR 25 |
| Riding Boots | CR 15 |
| Automobile | CR 9300.00 |
| Apartment | CR 10/month |
| Middle class house | CR 35/month |
| Trained house hold slave | CR 350.00 |
| Labor slave | CR 40.00 |
| Assault rifle | CR 2500.00 |
| Semiautomatic pistol | CR 1900.00 |
| Trade rifle | CR 40.00 |
| Cap and ball pistol | CR 52.00 |
| 50 Caps, powder and shot | CR 10.00 |
| Horse, riding | CR 35-150.00 |
| Milk cow | CR 56 |
| Radio | CR 120 |
| Television | CR 600 |

FORT BUNDY

Built near the ruins of Clover-port, Kentucky in 2042 after a particularly destructive cross-border raid, Fort Bundy is typical of the small border posts the Free State uses to fence in its thinly settled border regions. While Cloverport was mostly destroyed in the raid of 2042, a new, smaller town (Portown) has sprung up under the watchful eye of the fort. Portown is mostly just a stop for the steamboats on the Ohio where they can take on coal and food and occasionally offload goods for the locals or the Fort.

The Ohio is one of the great arteries of travel in the Free State and a fair amount of river travel and

trade takes place. Part of the job of forts like Bundy is to guard the borders, watch over this trade, collect taxes from it and make sure that no dangerous or forbidden items come into the Free State. This is, of course, impossible.

However, the Fort does serve as a deterrent and the occasional patrols sent out sometimes catch raiders before they can slip back across the Ohio. Fort Bundy should have modern means to cross the river in pursuit. But they don't. Only if the attackers are particularly flagrant or deemed dangerous enough to attract the notice of higher ups will a campaign be ordered across the River to "smoke the bandits out." Usually the bandits will have lots of warning and will simply move on before such an expedition even mounts up.

The usual result is that such reactive strikes typically cross the River, kill whoever they find and return with a body count to report to their superiors.

Relations between the Fort and the people of Portown are predictably strained. While the Fort protects the town from attack, they are also the tax collectors. To make matters worse, the soldiers of the Fort are not fond of the "stinking river scum" who "infest" Portown and will make their dislike known whenever they go to town.

As a result, while the people of Portown are not in open revolt, they have no fondness for the soldiers and will happily look the other way when one of them "disappears."

The walls of the Fort form a hexagon, with only one gate into or out of the Fort. Walls are brick faced and filled with rubble, 3.5 meters high and 4 meters wide at their base. They are topped by a 2 meter wide walkway with crenellated battlements that allow those inside the fort 75% cover from the outside, though no cover on the inside. Each corner has a 25 meter high machine gun tower whose walls are armor factor 25 and offer anyone in them 50% cover. The ladders to the towers are exposed. These forts are highly effective against poorly armed bandits but would be death traps if held against a modern army.

Viewed from a distance, the Fort seems almost quaint to the 20th century eye. Its buildings are all of red brick, salvaged long ago from the ruins of Cloverport. Building Three is an exception. It is obviously a stockade, built of concrete with small, barred windows. The walls obstruct any ground level view of the Fort, though the second story of each of the other buildings rise above them.

Parked within the fenced yard outside the stockade are two six-wheeled APCs in front of the jail and a jeep across the courtyard from the APCs.

Nearby, outside the fence but inside the walls, is a Science One vehicle, all weapons retracted, all panels

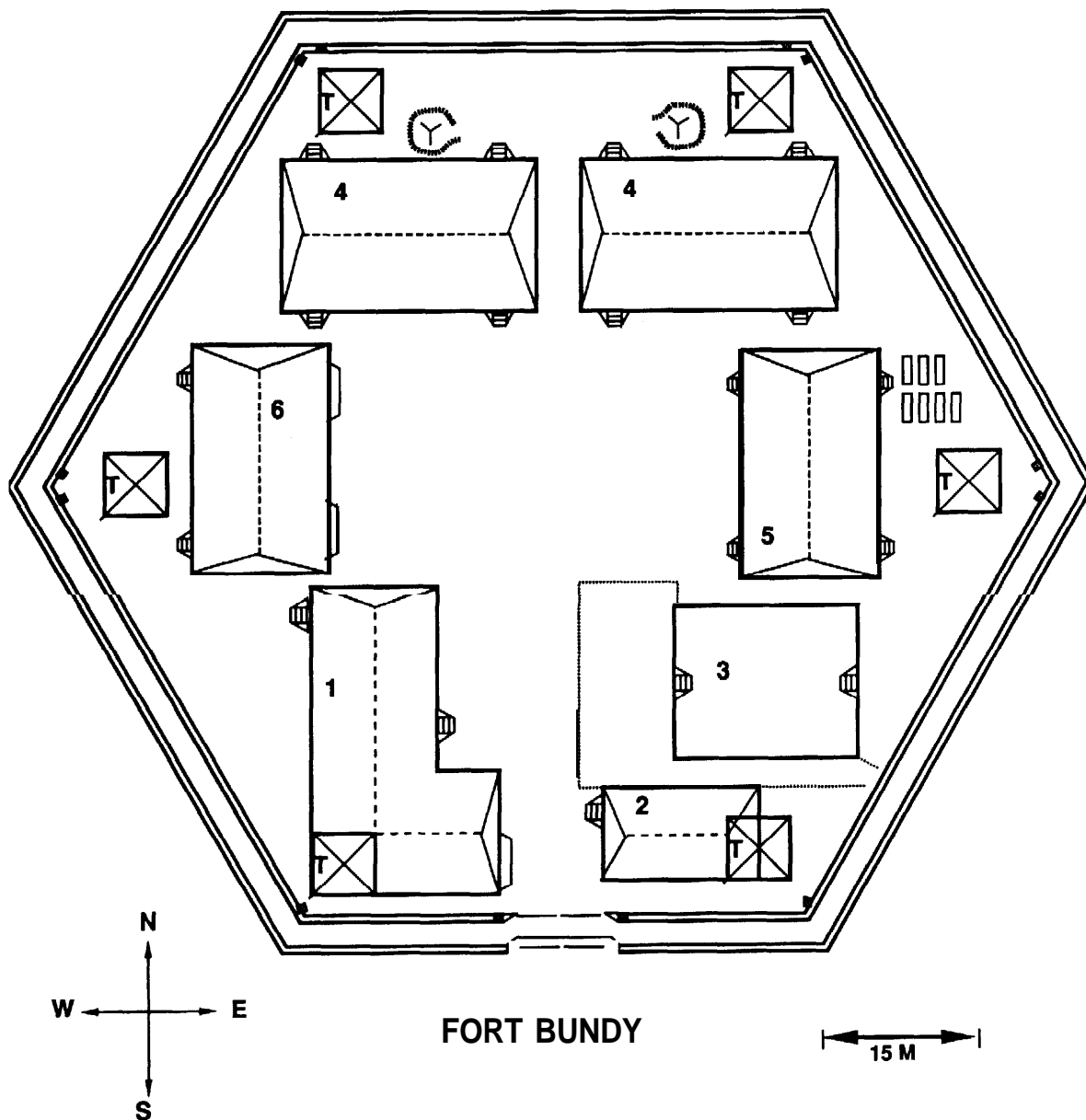

closed, and only a single passenger door open. Black garbed men with berets on move in and out of it while green-clad men with rifles and "Smokey-the-Bear" campaign hats patrol the walls.

The ground circling the fort is levelled and all brush has been cut away to a distance of 200 meters. The Fort is set above the Ohio floodplain, 350 feet above the River on a bluff above the floodplain. At night, 6 groups of 2 men each walk the walls, while two more men are in each of the 6 machinegun towers. A single light bulb burns above every door in the camp but there are no lights on the walls or in the towers. Noise and light discipline are very poor.

Each man in a patrol is armed with a Mini-14 assault rifle, 5-40 round magazines, bayonet, LBE and two CS grenades. Unless they are on alert, they wear felt "campaign" hats the same olive drab color of their uniforms. Rank is prominently worn on the right sleeve.

Each tower has 2 men in it. Inside each tower, in

addition to each man's personal weapon, is a .50 caliber machine gun (roughly the equivalent of the M2HB) and eight rifle grenades. These are bullet-catcher rifle grenades, which require no special ammunition or equipment for the rifle. Each tower has 4 HEAT rifle grenades and 4 illumination rifle grenades. Also, there are 6 -150 round boxes of linked .50 caliber ammunition for the machineguns.

In the armory, the Fort keeps 6 CETME machineguns which will be issued and on the walls if the Fort is on alert.

Full stats for the Mini-14, the CETME and the rifle grenades are in the New Equipment section at the end of the module.

Typically, one man in the tower sleeps while the other stands guard. Each tower has a pair of standard binoculars. Night vision gear is only issued during alerts. The towers are connected by a land line, an

internal (to the Fort) phone system. Another phone is in the Guard shack (bldg. #2).

The gates of the fort are doubled layers of cyclone fencing topped with a thick mass of rusty concertina wire. They are open during the day and shut at night.

HEADQUARTERS - BUILDING #1

This two story building is buzzing with activity during the day but shuts down completely at night. Only the officers have keys to this building. They live upstairs, though at least two of them are out and about, or at the Fiddler's Green, at any given time. At least one officer is always present.

First Floor

A1 Motor Sergeant's office. The motor sergeant, Sergeant Pallone works out of this room, supervising maintenance on the unit's jeeps, trucks, and the electrical generator for the camp, kept in the basement of the stockade. This isn't nearly enough to keep

Sergeant Pallone's squad busy, but they try to make it look that way. Despite Pallone's best efforts, his men are constantly being grabbed for details.

This room contains a desk (stocked with half a dozen bottles of liquor) hundreds of technical manuals and dozens of posters ranging in age from the latest to the truly ancient. Sergeant Pallone stays here as much as possible.

A2 Motor Pool - Here is where Sergeant Pallone's motor squad, part of the headquarters platoon, work and loaf - er, rest between details. The squad has a radio which they listen to constantly whether they are pretending to work on vehicles or not. There is a ramp on the east side of the building to allow vehicles in and out of this room. Currently there is a Free State "Deuce and a half", 2 112 ton truck in here being worked on in a leisurely way.

A3 Supplies for the mechanics are kept here - grease, oil, gaskets, tubes, tires and other nifty stuff.

A4 Briefing Room - If the Team can evade the guards and enter this room, it will be a treasure trove of information. They can discover codes, maps of other

FORT BUNDY HQ

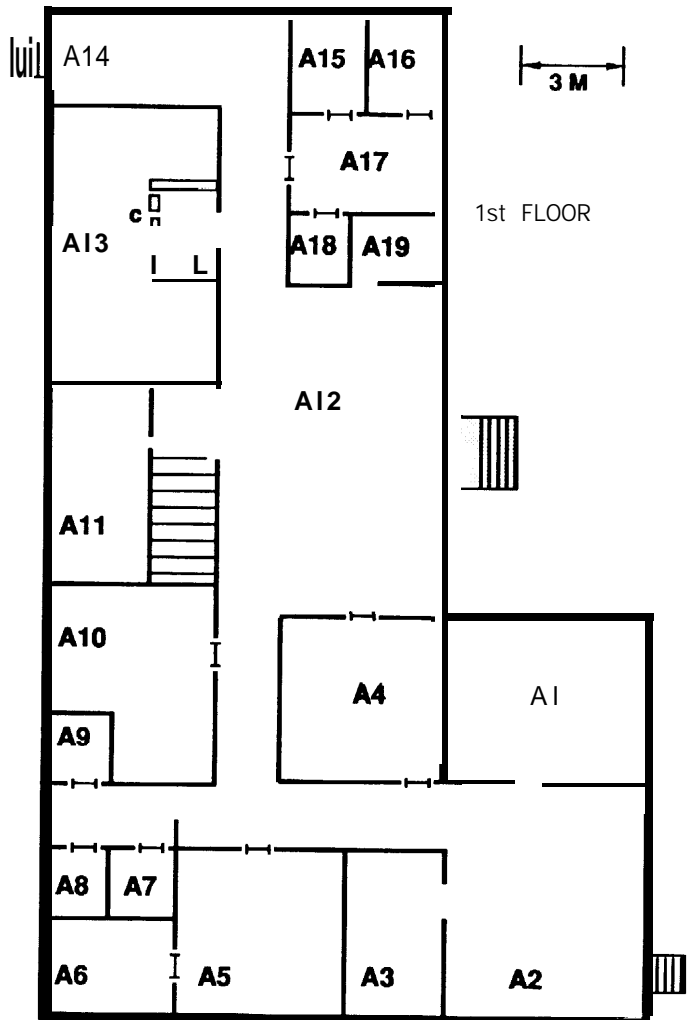
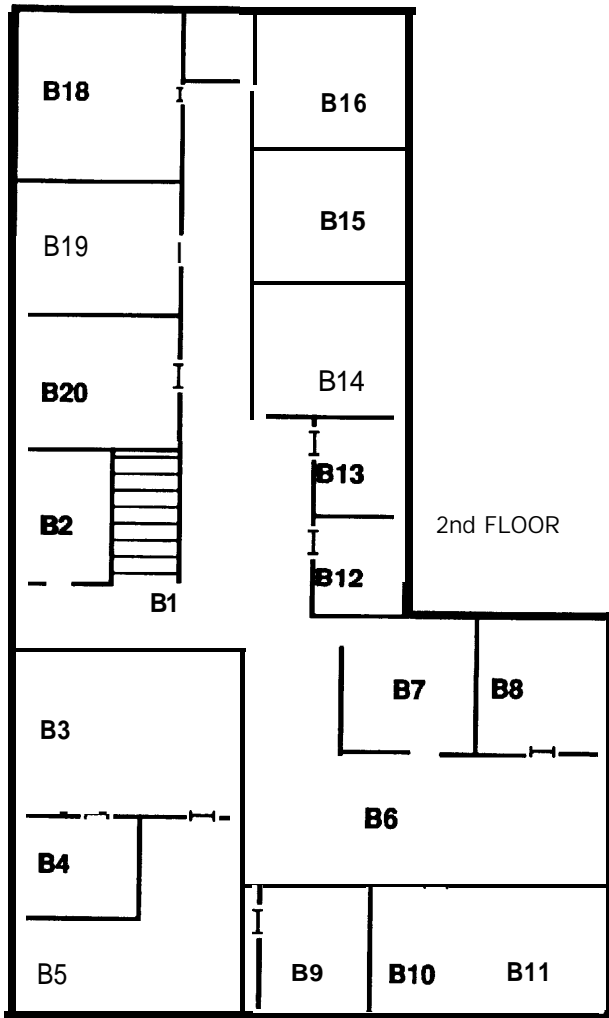

bases, tables of organization, etc. Most valuable of all, one careless officer left his regimental unit code book - a CEOI, for you grunts out there. This inoffensive yellow book is filled with ciphers, numbers and letters. Properly used, it enables the user to listen in on any communications on the Third Regiment, (this unit is one of six companies in the Third Regiment, Army of the Free State) including scrambled communications. It can also be used to insert its user onto the radio net, request information, and feed false information. The possibilities for havoc are virtually limitless, particularly since communications security in the Free State Army tends to be very sloppy.

A5 Doctor Zachary Taylor's office: "Captain Zac", as he calls himself, is the Fort's doctor. Operating out of this room, he supervises sick call and occasionally visits nearby civilians on house calls. This room contains large numbers of sterile dressings, general purpose medical supplies, several chairs and a desk. Doctor-style posters line the walls where shelves don't. All supplies are kept locked up, particularly the medicinal alcohol.

A6 Inner Office: this room contains locked cabinets of drugs and pharmaceuticals that would be worth three times their weight in gold across the river. It also contains an operating table, anesthetics, and full facilities for surgery. Locked in one cabinet, hidden in a box of cotton balls, is an ancient Police Positive .38 revolver with five rounds in it, and the hammer down on an empty chamber.

A7 Lt. Robinson's cubicle. This tiny office contains a desk, files and papers on fourth platoon. 20% chance of him being here during the day.

A8 Lt. MacLeans's cubicle. The same for third platoon.

A9 Lt. Takeda is generally in this room, preferring to let his platoon sergeant run his platoon, and concentrating on his engineering studies. He keeps a loaded Model 59 in the lower left hand drawer, and a bottle of bourbon in the lower right.

A10 Office of Major Thomas Carstairs the Fourth.

On the west wall are dozens of framed photographs of him with colonels and members of the Five Families, decorations he has received, a couple of newspaper clippings featuring him. This is his "I love me" wall. Careful observation will note that almost all of these are more than eight years old.

The Major's huge desk has a comfortable chair, while three uncomfortable chairs are for visitors. The southern alcove holds an extremely well stocked bar, while the Major keeps the cigar box on his desk well filled from his personal stock. There are several locked cabinets in the room, some containing classified information, and the unit safe. Only the Major and Captain Kirby know the combination. Inside are 60 forty credit gold coins, 124 one credit silver coins, and 300 credits in paper money.

Examination of the trash bin will find half a dozen whiskey bottles, all fairly fresh. The Major is here 60% of the time during the day, and is drunk 55% of that time.

On his desk is a manual - the official Free State Manual for dealing with Morrow Project Personnel. It is interesting reading for the MP team, and is stamped TOP SECRET in bright red letters, for obvious reasons. In it, it states that Morrow Project was an anarchist plot gone awry, partly con game and partly power scheme.

The existence of MP teams is not to be made general knowledge, but there is a possibility of scattered facilities of their's being discovered. If found, they are to be isolated. They are dangerous, full of unstable, poorly preserved explosives and biowar plagues. Further, due to flaws in their Cryosleep process, awakened Morrow Project personnel are dangerously unstable and violent. Coupled with the fact that Morrow unwisely recruited among politically unstable elements of the old United States, this makes Morrow Project teams a threat to peace and the general welfare.

If facilities are discovered, they are to be **IMMEDIATELY** reported to the Secret Police. If awake and functioning MP teams are discovered, they are to be isolated, and disarmed using whatever force is necessary, and the SP is, again, to be summoned. **UNDER NO CIRCUMSTANCES** are they to be permitted to agitate among residents and citizens of the Free State.

A11 Latrine.

A12 Front Office. This is where the 1st Sergeant, the Company clerk and two assistants hold court. Trooping are constantly in and out during the day, a large coffee urn (chicory, but still coffee) bubbles in the corner, and First Sergeant Loomis T. Clairbourne holds court. His current major concern is the regimental boxing championships, coming up in a month. Duty rosters, transfers, schools and other numerous items of paperwork keep him very busy.

A13 Supply Room, Staff Sergeant Barney Kohler operates out of this room. It contains blankets, spare boots and uniforms, field gear and dozens of other items of issue for the soldiers. Barney is a born conniver and scrounge, and had numerous deals going with Loomis Suggs. Barney is a competent but corrupt sergeant. You'll get a uniform from him eventually, but if you want one quickly, in good condition, it is likely a few credits will change hands. Responsible for keeping the Company supplied, Barney will always cheerfully inform you of how Regiment keeps screwing up his requisitions. This has made him so popular that Barney keeps a loaded pistol under the counter at all times.

All supplies are kept on shelves behind the counter.

A14 Odds and ends are stored here. At any given

BASIC LOAD (VEHICULAR) STANDARD ISSUE)

1 pr. AN/TVS-5 Binoculars 1 Machete
1 Laser Rangefinder 20m Tow chain (breaking
1 AutoNav navigation system strength 5.25 metric tons)
1 AN/PRC-70 3 Fire extinguishers
1 Radio Direction Finder Tool kit
1 Large MedKit 1 Shovel
1 Ax 1 Tripod (M122 or .50 Cal.)
1 Sledgehammer 2 Ration packs
1 Mountain Kit containing:
2-33m coils 11mm nylon rope (breaking strength 1,700kg)
1 Folding grappling hook 1 225 gram Hammer
20 Pitons * * * * *
30 Snaplinks * * * * *
6 M688 40mm Rocket shells (to launch grappling hook from M79)
* * * * * _ _ _
1 set Climbing spikes (for ice)
1 Trade pack containing;
50 Gold Double Eagles
* * * * *
50 Silver Dollars
* * * * *
6 one-liter bottles of Whiskey * * * * *
6 Sewing kits * * * * * 4 Mirrors * * * * *
6 Comb and brush sets * * * * * 6 Hunting knives * * * * *
6 250g packs Tobacco * * * * * 6 packs Candy * * * * *
Various toilet articles 6 Fishing kits * * * * *

1 M21 Rifle, 20rd mag, Semi-Auto, E=17, 12 mags.
* * * * * _
* * * * * _
* * * * * _
* * * * * _
ARMBRUST 300, Single-shot, E=441, Dpw=533 (4)
* * * * _ _
1 case M34 White Phosphorus Grenades (16)
* * * * * * _ _ _
1 case M26A1 Fragmentation Grenades (30)
* * * * * * _ _ _
1 case M7A3 CS Gas Grenades (16)
* * * * * * _ _ _
M183 Demolition charge (16 M112 C4 blocks)
* * * * * * _ _ _
1 roll Primercord (152m)
10 M2A1 Detonators (8 second delay)
* * * * * * * _ _ _
2 M1 Timers
* * _ _ _
2 M18A1 Claymore mines
* * _ _ _
1 case 9x19mm Ball (2880 rds)
1 case 7.62x51mm Ball (920 rds)
1 case 5.56x45mm Ball (1640 rds)
1 case 12 gauge magnum 00 buckshot (500 rds)

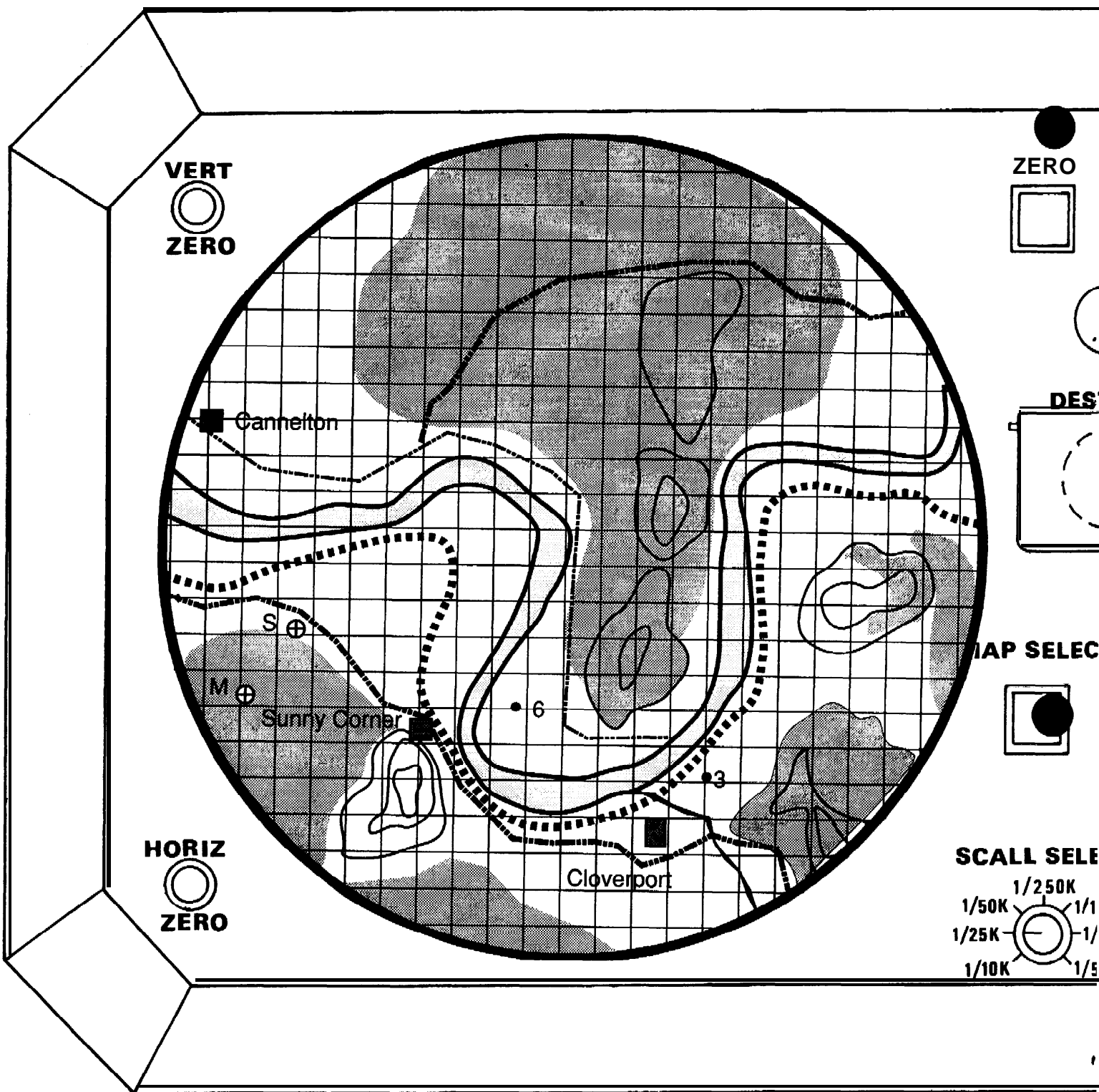

VERT ZERO; Allows adjustment of the displayed map to the unit in the vertical plan.

HORIZ ZERO; Allows adjustment of the displayed map to the unit in the horizontal plane.

ZERO; Allows the use of the Vert and Horiz adjustment dials.

DESTRUCT ARM; (covered toggle switch) Arms the destruct system causing a beeping sound once per second until fired or disarmed.

DESTRUCT; (covered push button) With the seal wire broken, cover lifted, and button depressed the system fires an internal thermite charge in five seconds. The charge destroys the interior of the AutoNav

MAP SELECT; Initiates system allowing the use of the keyboard to select a specific map.

SCALE SELECT; Determines scale of map displayed.

KEYBOARD; Used to input information into system.

SENSOR SYSTEM SELECT

RDF: Allows radio direction finder (if available) on display screen.

MAG: Allows magnetic sensor (if available) on display screen.

RADAR: Allows radar set (if available) on display screen.

CACHE LOCATION; Shows all assigned cache locations on display screen.

LIBRARY; Reads out all available maps on display screen.

BASIC LOAD (VEHICULAR) SK-5 HOVERCRAFT

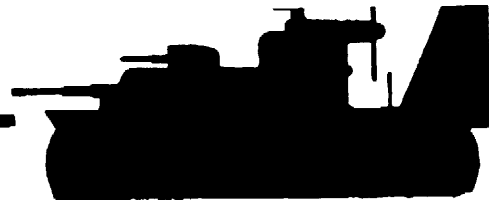

1 Rh202 20mm cannon, 100rd belt, Selective-fire, E-63 (Armor Piercing Incendiary ammunition), E=57, Dpw=40 (High Explosive Incendiary ammunition), 7 belts (4 HEI, 3 API), Short burst=10rds, Medium burst=20rds, Long burst=30rds-

HEI (4 belts) *****_*****_*****_*****_---

API (3 belts) *****_*****_*****_---

1 set Twin M85C Machineguns, 105rd belt, Selective-fire, E=30, 12 belts, Short burst=10rds, Medium burst=20rds, Long burst=30rds.

Right Gun *****_*****_*****_*****_-

*****_*****_---

Left Gun *****_*****_*****_*****_-

*****_*****_---

2 M174E3 Grenade launchers, 150rd mag, Selective-fire, Dpw=100 (M381 High Explosive), 2 mags, Short burst=4rds, Medium burst=8rds, Long burst=12rds.

Starboard Gun *****_---

Port Gun *****_---

2 M134 7.62mm Miniguns, 1,500rd belt, Full-auto, E=17, 6 belts, Short burst=100rds, Medium burst=200rds, Long burst=300rds.

Starboard Gun *****_*****_*****_*****_---

Port Gun *****_*****_*****_*****_---

* = Short burst

- = Reload

--- = Out of ammunition

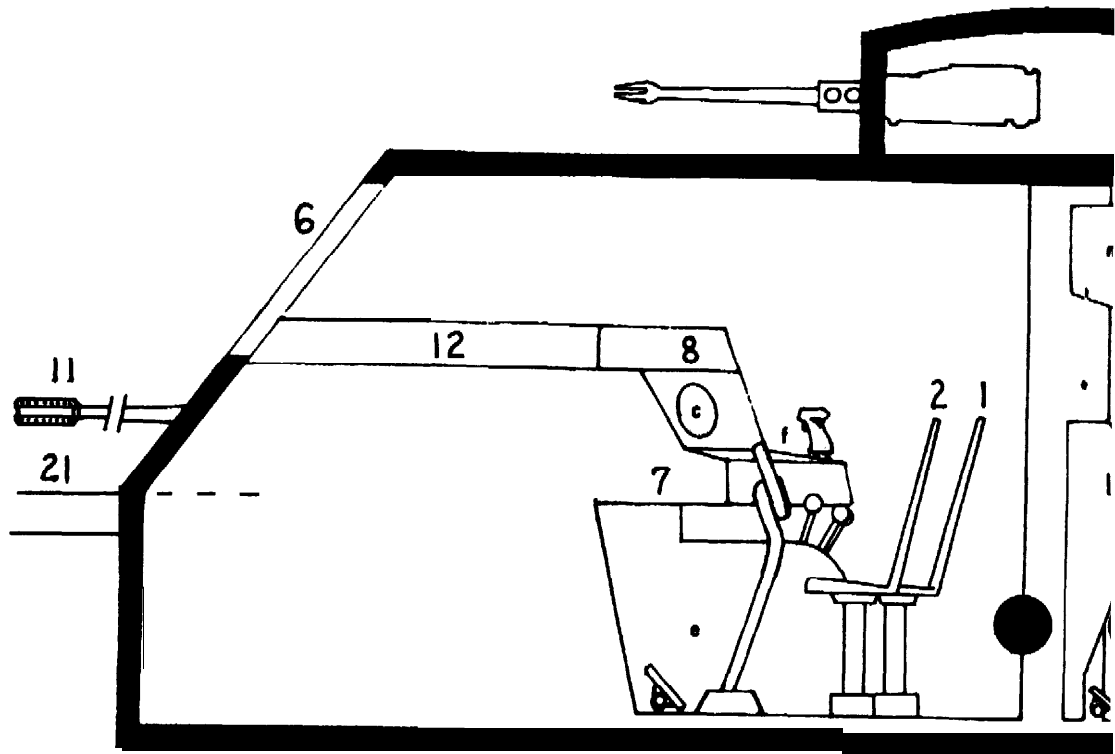
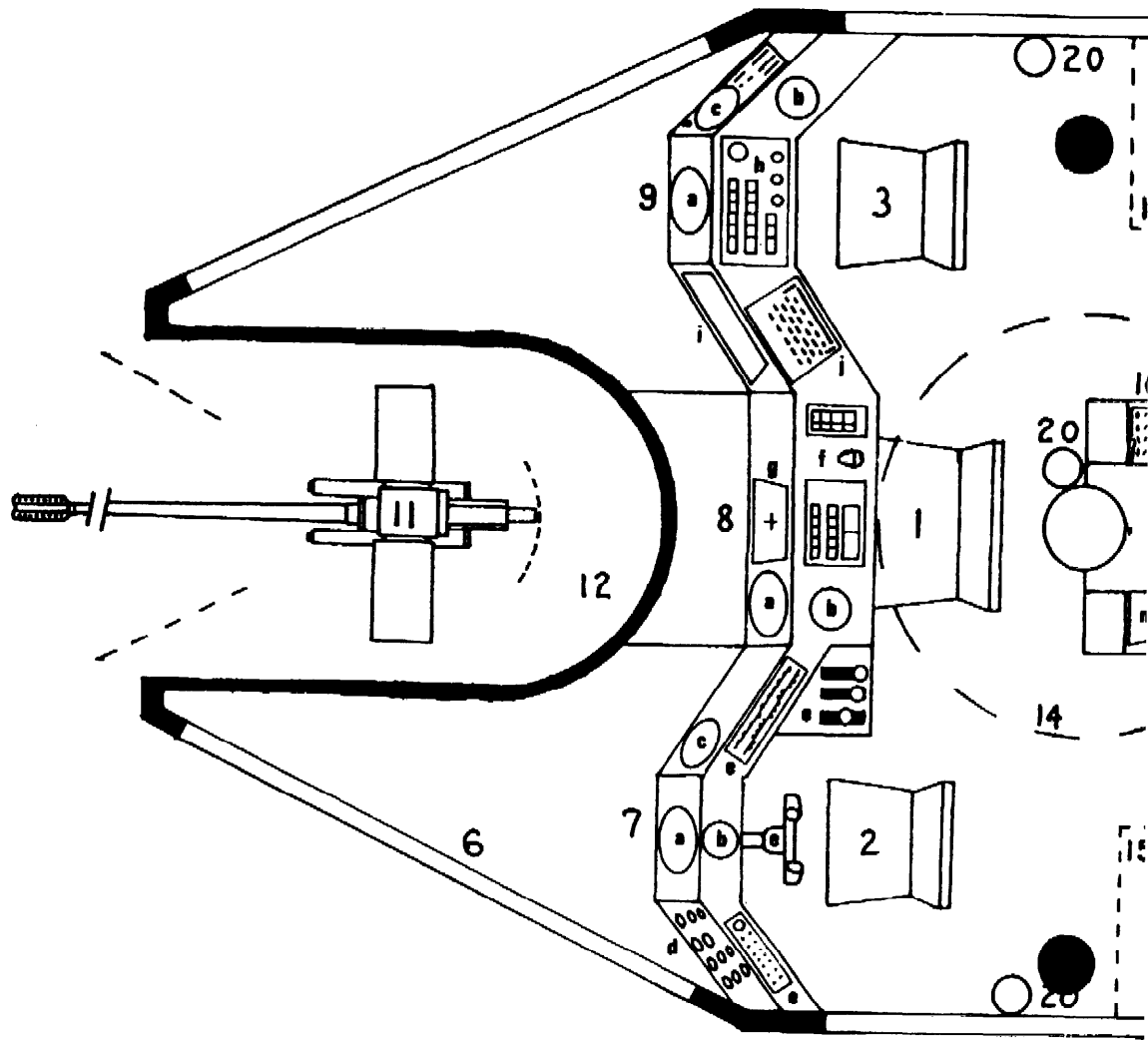

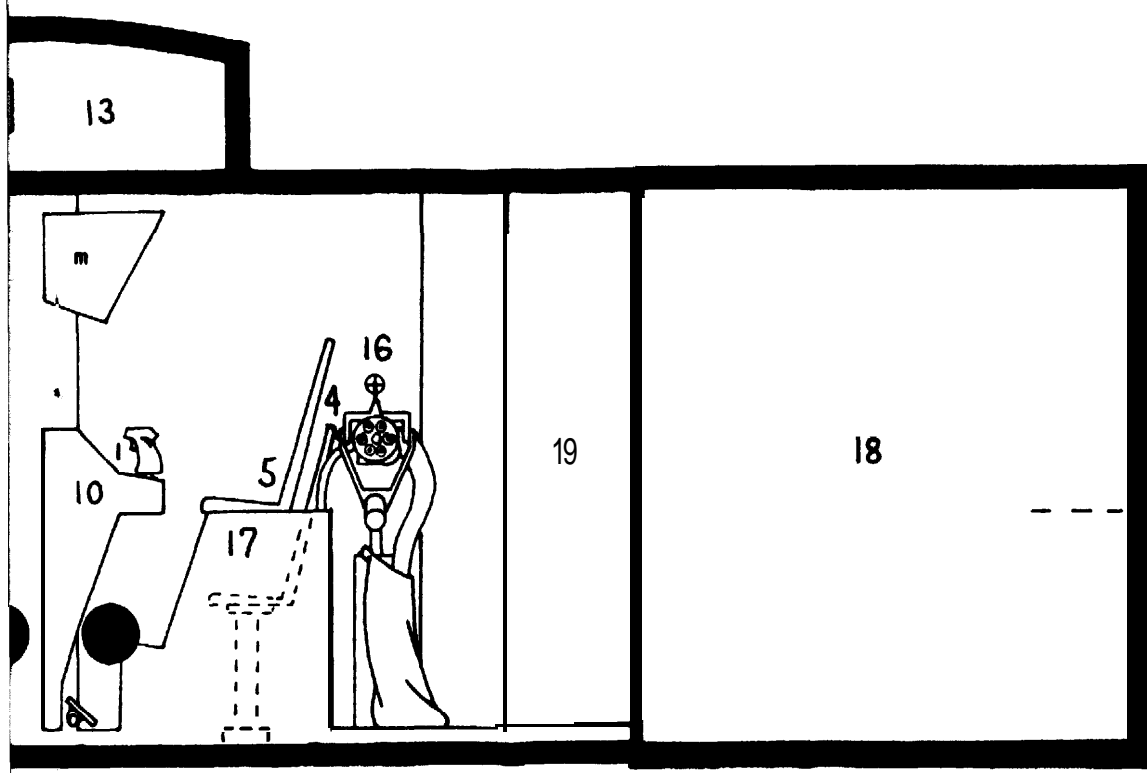
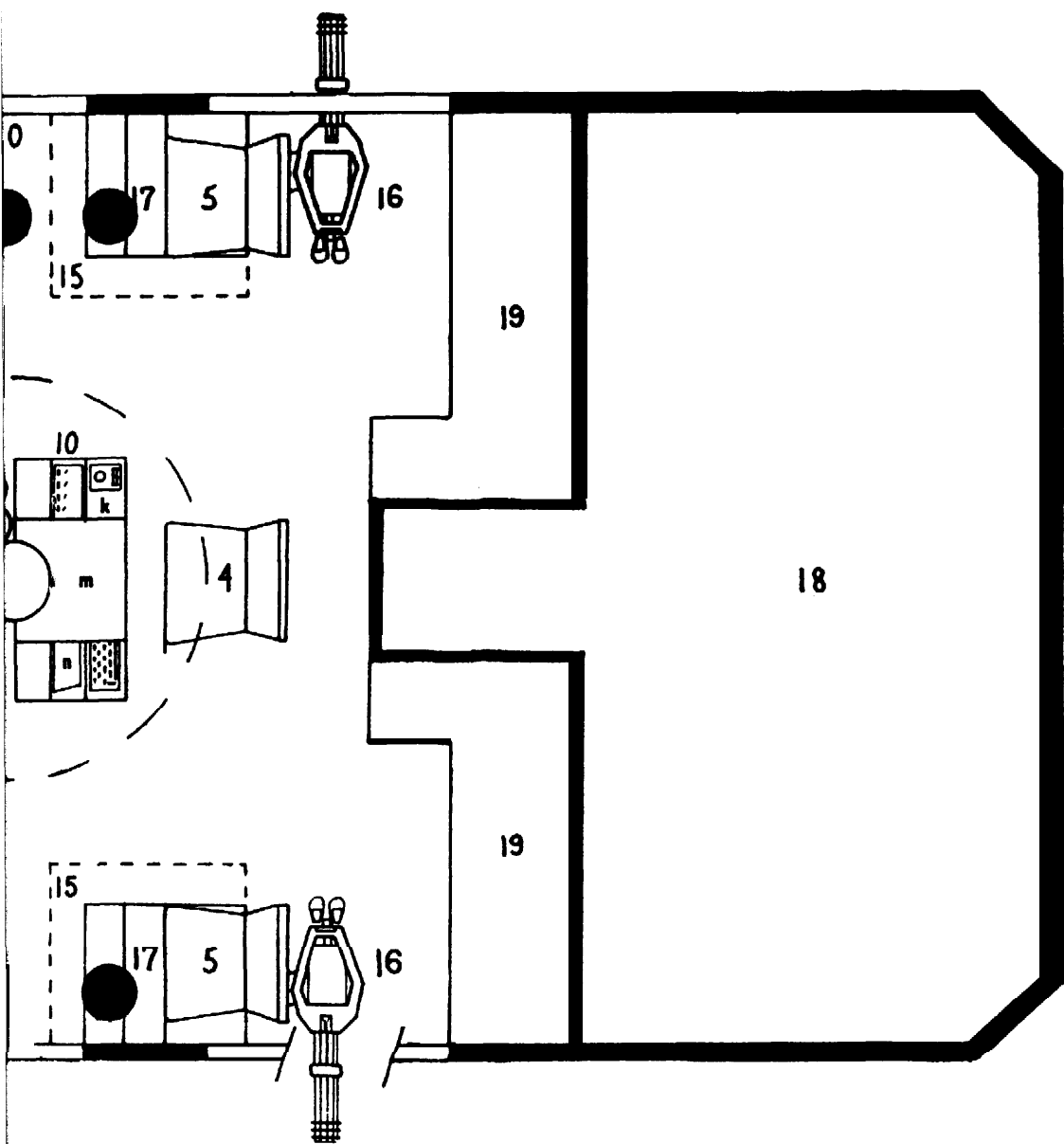

INTERIOR KEY: SK-5 HOVERCRAFT

| NO. | QTY. | DESCRIPTION |
|-----|------|----------------------------------------------------------------------------------------------------------------------------------------------------------------------------------------------------------------------------------------------------------------------------------------------------------------------------------------------------------------------------------------------------------------------------------------------------------------------------------------------------------------------------------------------------------------------------------------------------------------------------------------------------------------------------------------------------------------------------------------------------------------------------------------------------------------------------------------|
| 1 | 1 | COMMANDER'S SEAT |
| 2 | 1 | PILOT'S SEAT |
| 3 | 1 | NAVIGATOR'S SEAT |
| 4 | 1 | .50 cal. GUNNER'S/RADIO OPERATOR'S SEAT |
| 5 | 2 | WING GUNNER/PASSENGER SEATS |
| 6 | 6 | VIEW PORTS |
| 7 | 1 | PILOT'S CONSOLE & CONTROLS <ul style="list-style-type: none"> a. Radar Display b. Compass c. Auto Nav Display d. Piloting Instruments Display e. Asst. Piloting Controls |
| 8 | 1 | COMMANDER'S CONSOLE & CONTROLS <ul style="list-style-type: none"> a. Radar Display b. Compass f. RH202 Fire Controls g. RH202 Targeting Screen |
| 9 | 1 | NAVIGATOR'S CONSOLE & CONTROLS <ul style="list-style-type: none"> a. Radar Diiy B. Compass c. Auto Nav System (controls 40mm launchers) h. Radar Controls i. Computer j CRT & Keyboard for item i. |
| 10 | 1 | .50 cal. GUNNER'S/RADIO OPERATOR'S CONSOLE & CONTROLS <ul style="list-style-type: none"> k. Radio and RDF Controls l. Fire Control for Twin .50 cal. Turret (automated) m. Targeting Screen for Twin .50s n. Alternate Computer Controls |
| 11 | 1 | RH202 CANNON (AUTOMATED) |
| 12 | 1 | ARMORED HOUSING FOR ITEM 11 (ACCESS HATCHES SET IN ROOF OF MOUNTING) |
| 13 | 1 | TWIN .50 cal. TURRE T (AUTOMATED) |
| 14 | 1 | .50 cal. TURRET RING |
| 15 | 2 | VEHICLE ENTRANCE/EXIT HATCHES |
| 16 | 2 | 7.62mm MINIGUNS ON PEDESTAL MOUNTS |
| 17 | 2 | BASES FOR ITEM 5/AMMO AND FEED SYSTEMS FOR ITEM 16 |
| 1a | 1 | FUSION POWER PLANT |
| 19 | 2 | STORAGE LOCKERS CONTAINING: <ul style="list-style-type: none"> 2 AN/PRC RADIOS 1 LASER RANGE FINDER 1 AN/TVS-S BINOCULARS 11 CASE EACH: 12 Gauge Magnum 00 Buckshot, 5.56mm Ball, 7.62mm ball, 9mm Ball 4 Armbrust 300s 1 Large MedKit 1 Tool Kit 1 Explosives Locker 1 Case, M7A3 CS Gas Grenades 1 Case, M34 White Phosphorous Grenades 1 Case, M26A1 Fragmentation Grenades 1 Each: Ax, Sledge Hammer, Machette, Shovel, Tripod 1 M21 Rifle w/12 Magazines 1 Mountain Kit 1 Trade Pack 2 Ration Packs 1 Case, M18A1 Claymore Mines 600 Rounds 20mm; 6,000 Rounds 7.62mm; 840 Rounds .50 cal. |
| 20 | 3 | FIRE EXTINGUISHERS |
| 21 | 1 | LEVEL OF EXTERIOR DECK |

DESTRUCT ARM

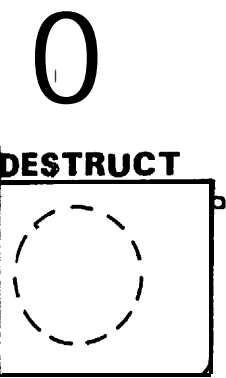
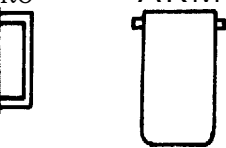

KEY BOARD

| | | |
|-------|-----|-----|
| 1 | ABC | DEF |
| 2 | | |
| 3 | | |
| GHI | JKL | MNO |
| 4 | 5 | 6 |
| PQR | STU | VWX |
| 7 | 8 | 9 |
| 0 | . | CLR |
| ENTER | | |
| A | B | C |

GUN SYSTEM SELECT



CARD SLOT

AMMO SELECT

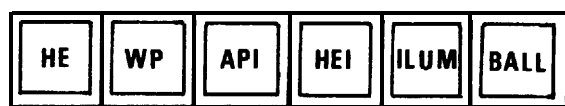

SELECT

CACHE LOCATION

LIBRARY

RANGE

AZIMUTH

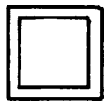
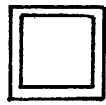
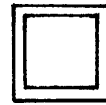
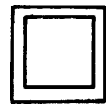

TARGET DATA

DISPLAY

SELECT

SENSOR SYSTEM

SELECT

GUN LAY

TGT

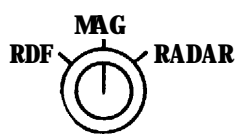

available to AutoNav) to indicate direction on display

available to AutoNav) to indicate location of detected

e to AutoNav) to indicate detected targets on display

red caches when depressed.

ps on display screen.

GUN LAY

MAN; Disengages Gun Lay system to allow manual laying (aiming) of gun system. AUTO; Engages Gun Lay system to aim weapon system according to data In AutoNav.

GUN SYSTEM SELECT; Allows AutoNav to aim indicated weapon system, if vehicle is so equipped, using Gun Lay system.

AMMO SELECT; Indicates ammunition fired in selected Gun System.

TARGET DATA

RANGE; Allows input of data for Gun Lay system.

AZIMUTH; Allows input of data for Gun Lay system.

DISPLAY; Indicates data, either Target or Location, shown on display screen or keyed Into system from keyboard.

CARD SLOT; Allows insertion of Morrow I.D. card to activate AutoNav displays. AutoNav will function (track its movement) without card but will not display any information or allow any other functions.

NOW AVAILABLE!

HOLY WARRIORS

by William Hamblin, Ph.D.

Two scenarios, 64 pages, 8 chapters,
A Module Of Faith, Intrigue and Death During The Crusades For:

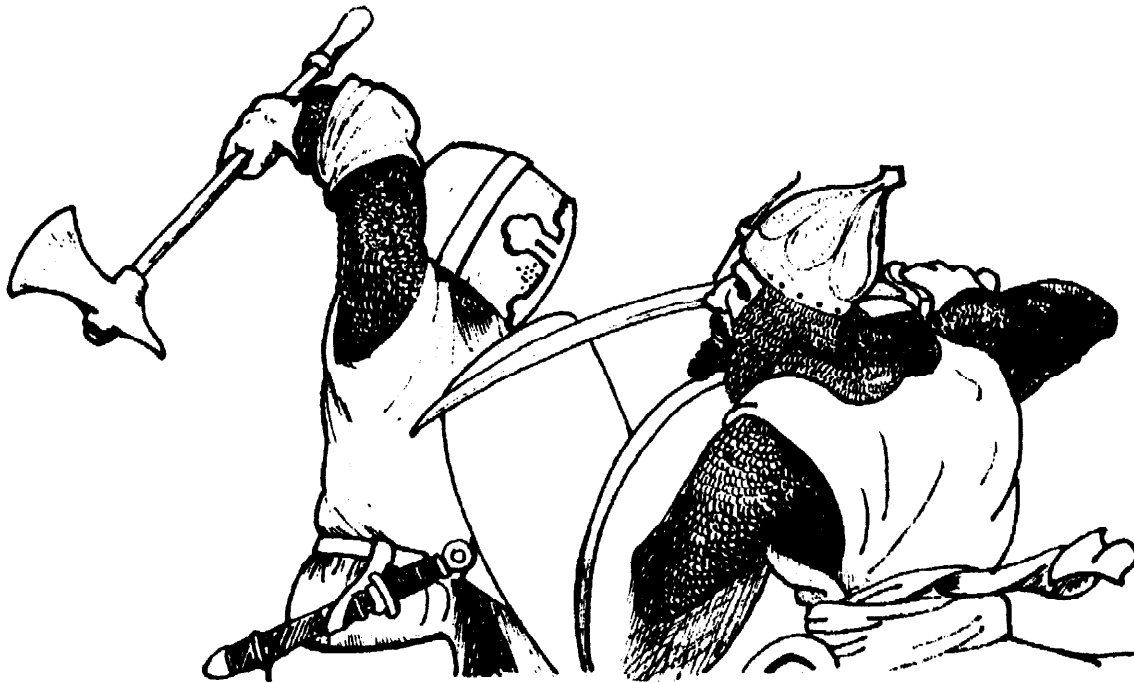

Time & Time Again

The Time Travel Role Playing Game



FROM:

TIMELINE LTD

P.O. BOX 60
YPSILANTI, MICHIGAN 48197

time during the day, two or three soldiers are here shooting the breeze.

A15 The offices of Lieutenant Thomas Erwin Vanderbilt the Third. He also has an "I Love Me" wall. Hidden beneath one of the drawers in his desk are notes - letters between him and other members of "The Spartans". All discuss the reliability of certain officers. They refer several times to "the Switch".

On the back of the door to this office is a scarred dart board, while there are half a dozen bayonets on his disk. He entertains himself on slow days by practicing knife throwing.

A16 Lt. Doug Masters' office. The owner of this office is a weapons buff, as is shown by this room. Seven different weapons, all in firing condition, are displayed in this room, ranging from an ancient, pitted but still functional M1911 .45 automatic to a heavily engraved trade Rifle. He has 20 - 100 rounds for each weapon. His flak vest and battle coveralls are kept in this room at all times. The coveralls are mottled camouflage pattern coveralls of resistweave, with kevlar panels (E factor 10) sewn over the front of both thighs. His flak vest is a kevlar vest similar to the Team's, but of slightly inferior make. It is only E factor 12. Masters is the Platoon leader for the weapons platoon.

A17 Empty.

A18 In this room a corporal (invariably called "Sparks") mans the PRC-70 base radio, and keeps an eye on the six PRC-70 backpack radios assigned to the company. A 24 hour radio watch is kept here, with the radio hooked to the 60 meter high radio antenna/tower outside the HQ.

A19 Captain Palmer Kirby's office. In this open office, he does most of the actual officer work of running the camp. He gets along famously with the First sergeant by listening to whatever he says and following his advice. He also has a pistol in his desk, but never keeps it loaded.

Second Floor - Officer's Country

Only cleaning details are permitted up here, and they are told in no uncertain terms to stay the hell out of the officers' private rooms. The private rooms are kept locked by the officers anyway. The rooms are luxurious by the standards of the Free State. In each officer's room, by regulation, is kept a "Mutiny Gun". This is an Atchisson assault 12 gauge, with three 20 round drums. As the title might imply, it is to be used in case of mutiny, giving the officers a substantial close range firepower superiority over their men. While rare, mutiny is not entirely unheard of.

B1 Hallway - A few flags and framed posters are on the walls.

B2 Utility closet - Brooms, mops, cleaning fluids,

etc. A great place for an aspiring infiltrator to hide. The door is not locked and looks like all the other doors on this floor (aspiring infiltrators better guess right).

B3 The living room to the Major's suite - Luxuriously furnished with couch, lounge, TV and bar, this room would not be out of place in a 1960s upper middle class home, except for the impressive collection of trophies stuffed and mounted on the wall. A gun case against the wall houses several rifles, ammunition, and the Major's Mutiny gun. The hunting rifles and shotguns are clean, well-oiled and look recently used.

B4 Bathroom, complete with tub, shower, etc., all salvaged from the ruins of Cloverport over a hundred years ago.

B5 The bedroom to the suite - a royal mess, littered with empty whisky bottles.

B6 Another hallway, decorated with more flags, framed posters, and a small collection of swords left by a deceased former resident.

B7 The officers' lounge - couches, chairs, a TV, card table, poker chips and cards are in this room.

B8 Lt. Takeda's room. One of the officers courting Cassie Tucker, he has four banned books hidden under his bunk - actual histories of the 20th century, rather than the fabrications of the Rich Five. His mutiny gun, unloaded, is here.

B9 Capt. Taylor's room. Medical books abound.

B10 Capt. Kirby's room. As luxurious as Carstairs', much tidier. Unloaded mutiny gun in the corner.

B11 Numerous approved books and magazines litter this bedroom. In a locked chest are half a dozen remote microphones - bugs. There is also a receiver, a miniaturized tape recorder, a dozen tapes, and an instruction book. Also here are extensive notes on conversations between Lt. Vanderbilt and Lt. Masters that could convict both of them for treason for belonging to "The Spartans".

B12 Lt. MacLean's room. A small room befitting a junior officer.

B13 Lt. Robinson's room. The same.

B14 Lt. Vanderbilt's room. Well furnished, this room sports an assortment of hunting rifles, shotguns and target pistols. His mutiny gun, oiled and loaded, is over in the corner.

B15 Lt. Masters's room, much like Lt. Vanderbilt's.

B16 This is a guest room, presently being used by Major Getter. His two attack dogs, Himmler and Heydrick, are left here and will savagely attack any interlopers. Note - these dogs have been operated on so as to make them mute. They neither bark nor growl.

B17 Part of the guest suite, this room contains the trade packs from the Science One.

B18 Another guest room, unoccupied.

B19 Shower room.

B20 Officers latrine.

BUILDING #2 - GUARD SHACK

Just a ready room for guards not in towers.

BUILDING #3 - STOCKADE

(See at end.)

BUILDING #4 - BARRACKS

The two barracks buildings each house two platoons of enlisted men, their officers sleeping in Building #1. The barracks are long bays with bunk beds, foot and wall lockers, and not much else. At the end of each bay are four rooms. One room contains the assigned ammunition of the platoon, one room is for the platoon sergeant, one office which the platoon leader and the platoon sergeant share, and a latrine with showers takes up the fourth room. About 60 men are billeted in each barracks. Each soldier sleeps with his rifle and 5 - 40 round magazines, but no ammunition. Ammunition is kept under lock and key, and only the sergeants have keys. In each ammo room, two to a barracks, are kept:

- 7 cases - 5.56 ball ammunition
- 3 cases - 5.56 linked ammunition
- 1 case - HEAT rifle grenades
- 1 case - Illumination rifle grenades

20 weapons cleaning kits, and three boxes, 50 rounds each, of 9mm ammunition. All officers and NCOs (sergeants and corporals) are issued sidearms as badges of rank, and are also permitted to keep ammunition with them at all times. The two barracks contain the three rifle platoons

BUILDING #5 - MESS HALL

The first floor contains typical mess hall things. Long tables, benches, a large kitchen, the whole nine yards. Two nights a week, movies are shown from an assortment of films kept with a projector and movie screen on the second floor. Food is stored in the basement, while the second floor has classrooms, storage space and sports equipment. Major Carstairs is intensely interested in the Company teams doing well in Regimental sporting competitions, seeing it as a way of reminding HQ of his existence. Several bulletin boards are in this building, and much useful information can be gleaned from them. One of the rooms also has a television and radio, and is often used as an impromptu day room.

BUILDING #6 - VEHICLE BARN

This building is where the Fort's vehicles are kept. Within it are three M2s and a jeep. The jeep is a M151A1 1/4 ton jeeps described in **PF-01, Liberation At Riverton** (as is the one parked outside of the HQ) and has a pintle mounts for 5.56mm machine guns. Two of the M2s have mount the standard 25mm chain gun (detailed in **PF-02, Damocles**) and one has had the turret removed and an 81mm mortar put on the chassis. Unless the Fort is on alert the mortar will be covered by a tarp.

In a room on the northeast corner of this building .50 caliber and 25mm ammunition and 81 mm mortar rounds are kept. In it are the following:

- 50 cases - .50 caliber linked ammunition
- 40 cases - 25mm linked ammunition
- 20 cases - 81 mm mortar rounds (10 cases HE, 7 - WP, 3 - Illum.)

Also stored in this room are replacement barrels and spare parts. This room is locked at all times and only the Officer On Duty, the 1st Sergeant and the Major have keys to it.

BUILDING #3 - THE STOCKADE

The walls of this building are one meter thick concrete. What windows the building has are small, with inch-thick steel bars. Chain link fence forms a yard in front of this stockade, with two six wheeled APCs parked there, one of which has two men in it at all times. These are Cadillac Gage Commando V-300's with Cockerill 90mm guns. Full statistics for these vehicles are listed in the New Equipment section at the back of the module. Both are fully loaded with ammunition. One has two men in it, while the other one is empty and locked.

Just outside the fence is the Science One. Too large to fit into the yard, it was parked outside with two Secret Police personnel in it. Also in it are all the Science Team's weapons and equipment, or at least what the SP personnel haven't taken as trophies. Inside the Science One, only the driver's station is illuminated. No other controls are working or will work, although the team members can see that the Team Leader's MP Identity card has been inserted into the activation slot.

The MARS team leader knows the twelve digit code which if entered into the onboard computer, will activate all the functions of the Science One, both defensive and scientific. The Lockout Code, as it was called, was a, last ditch measure to ensure the security of such powerful vehicles as the Science One. Three team members of the Science Team know of the existence of the lockout code. The Team Leader specifically did not. The MARS team leader was informed as a backup, in case some catastrophe wiped out the Science Team in cryosleep.

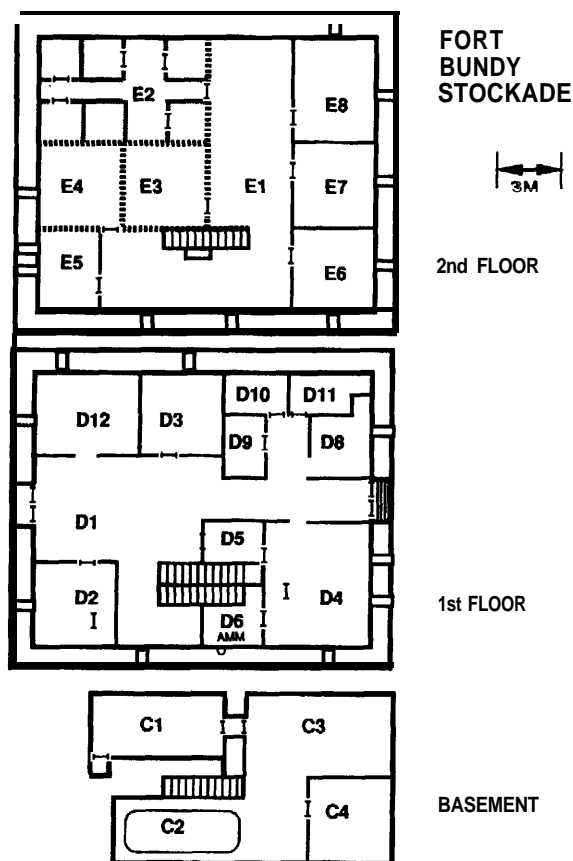

Stockade - Basement Level

C1 The Science Team leader, Dr. Milton Jeffries, is here being interrogated by Major Getter and two of his legbreakers. One of them is Corporal DeVass. Major Getter wants to know the lockout code for the Science One and refuses to believe that Jeffries doesn't know it. So far, Getter has held back from anything worse than a few beatings, but the longer this interrogation takes, the uglier it will get. In the corner is "The Box," a one meter by one meter cell specifically designed so that it is impossible for a human being to stand, sit comfortably or lie down in. It is used for reluctant prisoners and is completely soundproof.

There is no communications gear here, and if the rescue team has struck quickly they will surprise everyone here when they enter. The room is thoroughly soundproofed. PCs will find an older man showing bruises and a split lip manacled to the ceiling. With him in this dank, dark room is a lean, hawk-faced man in black fatigues with a holstered sidearm, and bronze oak leaves on his collar. This is Major Getter. With him are two thuggish looking gentlemen dressed in black coveralls, one with an Uzi SMG and 3-32 round magazines, the other with a Stoner Mark 23 assault rifle with four mags. Both weapons are over in the corner. If alerted, DeVass will grab the Uzi, the other soldier will use the Stoner, and Getter will use Dr.

Jeffries as a human shield. (his resistweave and kevlar vest are in his quarters). If things get desperate, Getter will try to use Jeffries as a hostage.

C2 A large tank of diesel oil for the camp generator in C4.

C3 this basement room contains plumbing, water heaters, fuseboxes and lots of other maintenance gear that provides wonderful cover for anyone seeking to ambush someone coming down the stairs. The NICO's have no chance of rupturing the fuel tank in C4, but any other hand grenade does.

C4 A large diesel generator is in here, locked in a chain link fence cage. The generator is the only source of light in the camp.

Stockade - First Floor

D1 Two SP troopers stand bored guard here. The doors are steel fire doors, kept locked at all times. One trooper totes around a full dress M60 7.62 MGF, a souvenir of the Science Team's equipment. The other has a MAC-10 with a basic load of ammo. If shooting starts the one with the MAC-10 will go to check out the door before heading down to warn Major Getter. The other will lock and load the M60, using the desk for cover and set himself up to cover the doorway. Note - the desk will not noticeably slow 7.62 NATO ammunition, but provides adequate cover versus 9mm and 5.56. Both guards wear resistweave coveralls dyed black, kevlar vests and PRC-68s.

D2 This office has been taken over by Lt. Trent Donfeller, Getter's second in command. Ambitious but rational, if he sees the MP team blitz the guards outside he will stay in this office. If the Team passes by he will exit and try to get to any undamaged V-300. If they have been destroyed, he will run to A18 to try to use one of the radios there to call for help. If the guards outside stop the attack, he will take command and try to grab the credit.

D3 The office of the regular jailer, Sgt. Lou Gutierrez. Gutierrez is displeased at having the SP take over his stockade, He is also nervous that they might somehow have found out he is with the Children of Liberty. He will hole up in his office to sit out this fight so long as the MP team concentrates on killing blackshirts. He will arm himself with the Atchisson 12 gauge and three drums of ammunition that are assigned to the stockade.

D4 A bunk room for the guards, if needed. It is presently where six off-duty blackshirts rest. All have resistweave coveralls and kevlar vests. Three have MAC-10s, one has an M-203 with twelve rounds of 40mm HE, one has and Uzi, and one has an M10A High Power. They are resting and it will take them several minutes to put on their body armor and arm themselves.

D5 Latrine

D6 An empty storeroom before the SP arrived, it is presently being used by one of the SP sergeants, Staff Sergeant Boddicker. He is sleeping here with half a case of C4, one MP Demolitions Kit, a Stoner Mk23 light machine gun, and four boxes of ammunition. Like the men outside, he will arm and suit up once the shooting starts. The SP trust no one and always have their own stores of ammunition; in the past they have needed them.

D7 This is the fusebox for the building. While not actually concealed, the Team would need an extraordinary amount of luck to find it on their own. No one other than a soldier or officer stationed in the Fort would know where it is.

D8 An unused office.

D9 Steel door with alarm. This is the stockade armory. Inside are four cases of CS grenades, two Atchissons, two cases of 12 gauge 00 buckshot and an M21 with four magazines and a starlight scope. Also here are 10 pairs of handcuffs and 25 leg cuffs.

D10 Stockade file room. Used very little, as the NCOs keep much of their discipline unofficial, this room is extremely neat.

D11 Sgt. Gutierrez's office. He has been avoiding it since the SP hit town, spending most of his time in his room. This suits the SP fine, as they content themselves with looting his cigar box, leafing through his papers and borrowing his chairs.

D12 An empty office.

Stockade - Second Floor

All doors on this level are one centimeter thick steel.

E1 Two bored SP guards stand watch here in full battle gear. One has an M79 grenade launcher, 6 rounds of 40mm stunbag and an HP-35. The other has 4 - M26 grenades and an Uzi with four magazines. Both wear resistweave and kevlar vests. A key ring hangs on the southern wall with keys for every door on this level.

E2 Six jail cells are set apart by half inch thick steel bars. In these cells are eight men and women in worn fatigues, all of whom show some signs of rough treatment. All are thoroughly confused. The SP told them that it is sixty years after the War and that the Morrow Project was wiped out long ago.

The walls in this room, E3, and E4 are brick rather than concrete. Small arms fire can chew holes in them. Three of the Science Team members - Angela Macklin, Dave Weissfeld and Tom Davies - know the lockout code, but they aren't talking. Due to what the SP has told them, unless they get proof that the Team is who they say they are, the Science Team members will believe the MARS Team to be just another ruse by the SP to trick the codes out of them. Morale is

extremely low.

E3 Another interrogation room, this one is presently empty. A ladder and a hatch in the ceiling give access to the roof from this room.

E4 The Fort drunk tank, presently the residence of ex-corporal Mike Burnsidel An absolutely typical Free State NCO, he is presently nursing a murderous hangover. The group will see a sick looking, tough young man with the impressions of his lost stripes still on his sleeves, He got into a fight with one of the SP at the Green Lantern and broke his nose. Note - knowing he is in dutch with the SP, he will eagerly join the MP team if they put on a strong show of force.

E5 Captain Barnard "Skip" Hughes is billeted here, examining his latest trophy - a Mark II laser taken from the Science Team. He also has a resistweave uniform with thigh pads, along with a kevlar vest. His sidearm of choice is an HP-35 He pulled a lot of strings to get on this mission in an attempt to get his stalled career back on track. This ambition, as well as eight years of desk work to separate him from reality, will cause him to be considerably braver than he would normally be.

E6 Sergeant First Class Clayton Hutch is sleeping in this room.

E7, E8 Empty storage rooms.

PERSONALITIES OF THE FORT

The Secret Police Detachment

Major John Paul Getter

A big, brown-haired man in his 30s, he is tough and ambitious, J.P. Getter is from the richest of the Five Families. Trading on his name, this mission will be the final boost he needs to make Colonel. He intends to be head of the SP. If attacked he will use the MP prisoners as hostages. While not an extreme coward, he has every intention of living to a ripe old age. His sidearm is a Morrow Project HP-35.

Major Getter fervently believes in the principles of the Free State: Slavery is Just, the Strong Survive, the Divine Right of Money. He views his work in the SP with something of the same religious fervor of an Inquisitor of the 15th century.

Captain Barnard "Skip" Hughes

Ambitious, but without the brains or guts to back up his plans. Hughes is a conniver and a weasel. He is a small, dark haired, brown-eyed man with a facial tic.

He is the opposite of the Major in that he is a cynical opportunist who believes none of the propaganda of the Free State; he's just ambitious. And, he enjoys his work. After all, where else can you make money, accumulate blackmail information and inflict pain and terror on people as part of the job?

Lieutenant Trent Donfeller the Third

Young, quiet and very dedicated, Trent is the very model of a junior Secret Police officer. He is also smarter than he seems. He has neither the fervor of Getter nor the cynicism of Hughes. He believes that the work is dirty but somebody has to do it. He has been undercover across the River and has seen a lot of chaos, pain and death. To him the Free State is to be preferred.

While he is quiet about it, he has no use for the corruption, incompetence and nepotism that is rampant in the Free State. Especially not in the ranks of the SP. He will crack the whip over any recruit under him who has a sloppy attitude toward their work. He comes from a good family and is not afraid to make other "young scions" toe the line. As a result he is not popular - but he is respected.

He carries a concealed .38 revolver at all times.

Sergeant First Class Clayton Hutch

Senior NCO among the Secret Police detachment, he is also the toughest and meanest among them. Curly-haired and blue-eyed, he would be handsome if he wasn't horribly scarred. He is vastly competent and seemingly without any trace of a conscience. He views officers as obstacles to getting a job done but he firmly believes in the military virtues and will never go directly against an officer. He is a rare bird in that he came over to the SP from the Army - he actually chose to do the work he is doing. This respect for the military makes him a particularly vicious opponent of The Spartans who he believes to be dangerous fools.

The only officer he particularly respects is Lieutenant Donfeller and the two of them make an unholy duo for newbies.

He has a PRC-68 with him constantly, will arm the minute any shooting starts, and coordinate any defense. Though he has his vest and resistweave, the only weapon he has with him is a S&W .44 Magnum. He favors the big handgun because it's loud, impressive and good for killing people.

Standard Secret Service Trooper or NCO

Arrogant and contemptuous, they have the power and they enjoy using it. Not all of them are sadistic killers, but they try. Typical secret police. They also share the usual failing of secret police in that they are generally not too good in a stand-up fight against evenly matched opponents. They depend on surprise, overwhelming numerical superiority and their knowledge of the situation to sucker-punch Morrow units.

Sergeant Hutch is an exception to this rule and

he will get the most out of his men in a fight, rallying them when they waver and disposing them in the best tactical positions that the situation permits.

The Fort Bundy Garrison - Company B, Third Regiment

Major Thomas Carstairs

Thomas Carstairs was, at one time, an up-and-coming young officer, particularly as he was married to the daughter of the patriarch of one of the Five Families. Promotions came quickly through his connections. Then his wife caught him with one of his numerous mistresses and divorced him. By then a Major, he was not only unable to advance without patronage, he actually had trouble holding his own.

He has spent the last 8 years posted to this backwater border fort. Somewhere along the time, he became an alcoholic. Stuck in this dead end, most of the work done by First Sergeant Claibourne, he morosely drinks away each day.

He has no tactical skill to speak of and for the most part leaves the running of the Fort to his subordinates. Under this laissez-faire leadership, nothing much happens. Where a vigorous commander would lead patrols on a regular basis, Major Carstairs not only never leads patrols, but positively avoids contact with his men.

The coming of the SP detachment has put the fear on him and he has ordered his officers to make a show of patrols, inspections and so on. He has even inspected the troops once himself (much to the surprise of his men, some of whom had to be told who he was).

In point of fact, he needn't have bothered. The SP know exactly what kind of officer he is and are not fooled by this busy look. Nor do they particularly care other than to insult the Fort's officer's when they can.

The exception is Lieutenant Donfeller who has taken a modest interest in terrorizing the Fort's inhabitants when he is not working with Major Getter and the Science Team.

Captain Palmer Kirby the Third

Tall and gawky, with an annoying tendency to snort when he laughs, Palmer comes from one of the best families and makes sure everyone knows it. He has followed the advice of his father who told him to stay quiet and listen to his First Sergeant. This is the only thing that has kept him alive this long. He lacks any semblance of tactical skill. On his own in a fight, he will take command immediately and do the worst possible thing for his own side.

He has also agreed to spy for the Secret Police, and has tapes linking Lieutenants Vanderbilt and Masters to the Spartans. He hopes to use this favor to the SP to get him out of this barbaric backwater and

back to civilization. What it will actually get him is further spying assignments in this barbaric backwater along with threats of what will happen if he doesn't come up with goods on a regular basis.

Captain Zachary Tyler

A young doctor who has recently completed his medical degree at Rockfaller University, Captain Taylor is working out his six year obligation as an MD. Unmilitary at the best of times, he is kept moderately busy by the garrison and by local civilians. Sensitive and cynical about the Free State, he serves because he knows of nothing better. His first concern is always to save lives. He has been called into the Stockade several times already by the SP to look at their prisoners and knows now that the stories of the MP personnel being dangerous lunatics is a lie. However, he knows that it is useless to try and fight the SP so he will simply do what he can to minister to the Science Team after they are "questioned" by the SP.

Lieutenant Thomas Vanderbilt

Short, slender and intense, he is egotistical, charming, ruthless and probably the most capable Army officer in the Fort. He constantly studies war and strives to appear as a soldier should. He worships military virtues and is a member of the military secret society, the Spartans. As such, he believes the military should rule the Free State preparatory to a great crusade to reconquer the United States. Well connected, he believes (wrongly) that his family can protect him from the Secret Police.

He came to the attention of Lieutenant Donfaller who has recognized him as a possible Spartan and has engaged him in conversation in hopes of getting confirmation of the fact and has set Captain Kirby to spy on him.

Lieutenant George Takeda

Eurasian in appearance, he is a hopeless romantic about the "glories" of the 20th Century. He is presently reading (and enthralled with) Winston Churchill's *History of the English Peoples*, one of the banned books he keeps in his room. He wants to talk with the MP personnel and learn what he can about the 20th century, but the SP have kept them isolated.

He is a competent if unimpressive officer who had visions of following a noble military career. The reality of the Army of the Free State combined with the misery of this outpost have left him disenchanted. He is prime fodder for recruitment by the Children of Liberty and Cassandra Tucker, who is the source of his forbidden books, is working on him.

He leaves his 9mm sidearm in his desk, preferring to carry a family heirloom - a Colt .45 Commander pistol. Originally his grandfather's and

then his father's, it is with him at all times along with two spare clips of .45 ACP ammo.

First Sergeant Loomis Claibourne

Big, brutal and tough, an ex-Regimental and all-Army boxing champion, he is used to making his incompetent officers look good. Blindly loyal to the Army, he is capable and incorruptible. He also owns a set of resistweave which he bought from an officer.

He has mostly been ignored by the SP who quickly tagged him as a career Sergeant and hence nothing for them.

He always carries at least one knife on him and he knows very well how to use it. During a fight he is the one who will generally take command and the troopers will follow his orders without hesitation, something which cannot be said of any of the officers.

Sergeant Willard Bechler

Sergeant Bechler is loud, garrulous and foul tempered. He smokes like a chimney as he meticulously cares for the weapons he has signed for. He dislikes the human race in general, and woe betide the trooper who drops his weapon when Bechler is around. He prefers to stay in the arms room at all times, and sleeps with a loaded S&W Model 59. He also has keys to every lock in camp, whether authorized or not.

He violently dislikes the "Blackshirts" as he thinks they are human carrion. He will cheerfully turn his back if a plot is hatched against them and if a firefight breaks out he may "accidentally" plug a few.

He knows Carstairs was posted here as punishment, knows what it was punishment for and makes no secret of the fact.



Typical Free State Officer

The family of a Free State officer typically purchase their son a set of body armor before he goes off to the Army. This consists of a kevlar vest (E-Factor 14), a kevlar helmet (E-factor 10) and a resistweave coverall in camouflage pattern, with an E-factor 10 kevlar pad stitched over the front of each thigh. Officers always wear these suits when going into a firefight.

Typical Free State Trooper

Unlike the officers, the typical soldier in the Army is an uneducated farmer. Their attitude is typically one of "don't care." They are treated with scorn by most officers, are issued little in the way of body armor and often join only because of the relative security the Army offers. As a result of all of this, they are completely lacking in initiative. Their attitude is "when in doubt, keep your head down."

Nevertheless, they are well trained, solid, common sense soldiers and while nowhere near to 20th century US Army standards, they are far better than anyone they are likely to meet. They are also completely unlikely to cooperate with any subversive movements (including the Morrow Project) as in general they do not believe things can get any better.

THE TAVERNS

Along the road leading to the Fort, where the road to the Fort meets the east-west road out of Portown are two large roadhouses: The Fiddler's Green and the Green Lantern.

THE GREEN LANTERN

Large and run down, the Green Lantern (known by many less printable names), caters to the common soldiers. Here the ordinary soldiers of the Fort can enjoy watered drinks, poorly prepared foods, and rigged games of chance, all in the long tradition of civilian service to the military. Sergeants and corporals get better treatment, both from the management and the bar girls. In return, they keep rough and ready order here. This is not to say that fights don't start. They just don't get out of control.

Furniture is solidly built and nearly indestructible, drinking mugs come without handles (less useful as a weapon) and drinks are sold by the pitcher or by the mug, never by the bottle.

The inn's namesake, a green painted lantern, lights the front of the inn. Kentucky Free State Currency, raw gold and silver, jewelry and furs are all accepted here if the trader is willing to be royally bilked. Presiding over all is the owner of the roadhouse, Loomis Suggs.

Loomis Suggs

A past master of the art of highway robbery, "Breaker" Suggs decided to go legitimate (or at least legal.) He built the Green Lantern (the only honest work he'd ever done in his life) 15 years ago and has since turned a large and steady profit fleecing the soldiers of Fort Bundy. He plays up to the senior NCOs and they, in turn, make sure he doesn't abuse their men past a reasonable degree. They also keep their men in line.

Suggs has extensive connections with bandits across the river as well as river pirates and often acts as a fence. Outwardly slow, little gets past him. A surviving bandit (if there were any) of the gang which attacked the bolthole will be in his bar the night of the day the team wakes up, drowning his sorrows (see *Play Of The Game.*)

THE FIDDLER'S GREEN

This tavern is clean, cheerful and exclusive. Located across the road from the Green Lantern, only officers and civilians are permitted. Inside, it is pleasant and moderately priced, accepting only Free State currency. It serves high quality food and drink and is a popular stop with the traders. It is usually at least half full. A widower and his daughter run the establishment.

Ostler William Tucker

His grandfather built this tavern, his father maintained it and Bill Tucker the Third isn't *about* to let his tavern become some common watering hole. He'll keep the unruly common soldier out come hell or high water. He worries some that Breaker Suggs is interested in Cassandra, but what truly worries him is that his own daughter, his only child, came back from Bowling Green with such wild ideas! She's at least had the sense to keep from bothering the customers, and the workers do seem to be happier since she started to be polite to them. But the girl has no respect for the Five or the Police! Well, if worst comes to worst he can count on his very good friend, Major Thomas Carstairs the Fourth to intercede should trouble start.

Physically William Tucker is a short, balding man with an obsequious manner, watery eyes and a figure rotund enough to show he is successful.

Cassandra Tucker

In her four years at Bowling Green's Rockfaller University, Cassandra studied political agitation with a minor in business management. Something of an anarchist at heart, she joined the Children of Liberty, and in the four years since she returned she has remained a radical, though discreet, champion of the Children's principles. In the process she picked up some training in conspiratorial activities, and so generally keeps her political beliefs to herself. However she is still young and can be impulsive.

She often deals with the officers from Fort Bundy and Major Carstairs has many times offered to make her his mistress (a dubious honor which she declines each time he repeats it.) Suggs' propositions, couched in even less elegant terms have incited even greater revulsion and disgust. She has been careful not to offend the Major given the value of the contact. She has been much less polite to Suggs. She knows the layout of the fort and can get inside and in the headquarters if she wishes. She must, however, enter alone as the guards will assume she is going to one of the officers quarters.

Part of her mission in returning to this area was to keep an eye on the border area for the Children. She has several ways of contacting confederates in the Children of Liberty and has been briefed on the Morrow Project to the extent that she is to report any information or sightings to her cell leader.

Sergeant Gutierrez is a member of her cell as is a trader in Portown (the village where Clovertown used to be). The trader is the cell leader and knows how to contact a Snake Eater 'A' Team operating on the north bank of the Ohio though this usually takes several days.

Gordon Baker

"Big Gordie" is a pale, towering giant of a man who does blacksmithing when he is not acting as a bouncer for "Mistuh Tucker." He talks slow but is also good natured and possesses a fair amount of common sense. If in pain, or if Cassandra is threatened, he becomes a savage enemy. He will also defend Ostler Tucker, but that's just a job. "Mistuh Tucker puts on too many airs. But Cassy, she a nice little girl." From the various barroom brawls he has been in he has learned a lot about hand-to-hand fighting.

PLAY OF THE GAME

The Team awakens to the sound of the breach alarm. This was an alarm set to go off and awaken the team from cryosleep if the integrity of the bolthole was breached other than by MP personnel using an ID. It was to go off if, for instance, water was entering the bolthole or a crack in its seals permitted the overpressure of neutral gas to escape from the bolthole. Wakeup from cryosleep takes time and the alarm will have been sounding for several minutes as the Team wakes. It is a part of the life support system of the bolthole and in addition to waking up the Team, it emits a low warbling sound to alert the Team to the fact that something is wrong. A switch to shut it off is located on the wall of the bolthole and can only be reached by getting out of the tube and walking over to it.

Examination of the bolthole will reveal why its integrity was lost. A series of large cracks have formed



in the ceiling and several fair sized chunks of masonry have fallen to the floor below. A successful engineering roll will reveal that someone tried to blast their way into the bolthole with an insufficient charge of explosives. Their charge, while not powerful enough to break through, did crack the seal of the bolthole. By listening, the Team will be able to hear picks and shovels being used to break in the concrete between two steel reinforcing bars.

If the Team uses their periscope, they will (briefly) see six men, all but one dressed in a mix of homespun. They carry tools and a variety of edged weapons and primitive firearms including what looks to be cap and ball revolvers. The exception to the rule is an adult male, heavily muscled and slightly overweight. He carries no tools, is dressed in brown khakis with shiny jackboots, wears a black campaign hat, an automatic pistol in a Sam Browne belt, has a pump shotgun and a shiny five-pointed star on his chest. As this archetypical sheriff, complete with mirrored sunglasses is spotted through the periscope, he will draw and cock his pistol and will then riddle the periscope with bullets.

The Team is now in an unenviable position. Their weapons are packed in cosmoline. Their equipment is sealed for long-term storage and armed intruders are trying to break in through their roof. All the PCs have is their personal gear. Cosmoline is the petrochemical equivalent of maple syrup. It is thick, sticky and hard to get rid of. Cleaning it off of the weapons so that they will fire is a long process, one which will not be completed by the time the roof gives in.

Things are not hopeless however and the Team has several options:

1. Fight. Not as hopeless as it may seem. If several Team members concentrate on clearing one small weapon, they can have it in firing condition in ten minutes. Their grenades are only in sealed containers

and can quickly be reached and deployed. A variety of other improvised weapons lie around the bolthole. The bandits are not watching the escape hatch or the main exit so the Team will have surprise on their side.

2. Talk. This will not work. The people outside the bolthole are not interested in prisoners or in giving them extra time to whip up any nasty surprises. A threat to set off the explosives in the bolthole might slow them down however.

3. Run. Throw everything into the SK-5, open the main exit and leave. This is a halfway option. If the Team stays buttoned up inside their Hovercraft, the small arms fire of the raiders can't reach them. However, while the SK-5 is capable of carrying all its own gear and eight crew, it cannot carry the packing cases, wooden cartons and metal drums they are packed in, not to mention the 55 gallon drum of solvent. They will have to leave half their gear behind in the bolthole. If this occurs, the raiders will collect their gear and leave. Upon returning to his town, Sheriff Cliburn will report a Morrow Project unit in his area and the Army and Secret Police will take over from there.

The Intruders

The intruders are a gang of 13 river pirates led by a red-haired sparkplug of a man named Rusty Hawkins and the local Sheriff, Booker T. Cliburn, and two of his deputies. The intruders are armed with single action cap and ball revolvers (see 44 New Model Army in the pistol section of the weapons sheet with the **Project Director's Screen, GA-1**) and cap-and-ball, "Trade Rifles." For further details on these, see the New *Equipment* section at the end of the module. Their ammunition is cheap round shot (E-factor 11) rather than the E-factor 14 Mine balls.

The Sheriff and his two deputies are the ones in the khakis and campaign hats. They carry S&W Model 59 9mm automatics and two spare magazines a piece. The Sheriff carries a .44 Magnum pistol as well. The deputies each carry a Remington 870 pump shotgun with the magazine extended so it will carry eight rounds. Each carries 24 rounds for his shotgun and uses 00 Magnum Buckshot.

There are 15 horses and three wagons parked 75 meters away from the bolthole under some trees. There are three bandits with the wagons.

Sheriff Booker T. Cliburn

Booker is a product of his society. He is brutal, but protective of his town. He is greedy, close minded and treacherous and knows a lot about the inner workings of The Kentucky Free State. It was his botched demolition job that woke the Team - he'd never seen reinforced concrete before.

One of Booker's cousins in the Secret Police was involved in the computer program designed to locate

the Morrow Project teams. The program found two in this area. When word of the Science Team's capture reached him, based on previous experience he was able to tip Booker on the likely area to look for a second team. A little scouting uncovered a partially exposed bolthole so the Sheriff set about putting together a "hunting party."

'Ole Booker T.'" had connections to a bandit gang that lived across the River, on the north side of the Ohio. He'd had a long partnership with them where he tipped them off to likely targets and they gave him a cut of the loot. He didn't know much about MP boltholes, but he knew they'd have more loot in them than he and his men could haul away or make "disappear." So he cut a deal. The bandits get most of the ordnance while Booker gets the silver, gold and resistweave. The rest of the loot was to be divided evenly.

Rusty Hawkins

The leader of the bandit gang, he is a born schemer and conniver. What he does best is survive. A firm believer in man as a tool-using animal, he is extremely good with knife and pistol. Trip-hammer reflexes combine with a keen instinct for when to fight and when to run. His knowledge of river life is encyclopedic. He believes the Free State propaganda that the "buried folk" are always crazy and dangerous.

Unless the Team acts quickly, once the bandits smash a hole in the roof they will come in, two at a time. First through will be a deputy, shotgun in hand. Next will be a bandit with two pistols. Rusty will send the men in while waiting outside the hole. If the first four intruders are quickly killed, they will change tactics. A large bundle of twigs and vines, smoldering furiously will be tossed into the hole by the bandits. It is wood wrapped with poison ivy vines and the fumes it gives out are at least as unpleasant as tear gas. In the next 20 minutes, two more bundles of smoldering foliage will be thrown into the bolthole, in an attempt to smoke out the Team. Gas masks will be moderately effective protection against breathing the fumes but exposed skin will soon exhibit all the symptoms of extreme exposure to poison ivy. As these bundles are lobbed in, the intruders will set themselves up in the treeline and try to pick off the Team members as they come out of their bolthole.

As the bolthole roof gives way, the bandits will initially gather round the hole to look in. A pair of grenades lobbed out of the hole by an alert group will catch six to ten of the bandits as they gather round to look in. Rusty will be among them. Subsequent grenades will not have any effect and there is a chance that they may be returned down the hole from whence they came (awkward).

A rush out the emergency exit will briefly surprise the bandits, but after the first person emerges, two

intruders with trade rifles will cover the exit. Once the intruders have taken up position, they are +30% to hit anyone exiting via those two holes. Smoke as cover and covering fire from Team members would help anyone making a dash under these conditions.

The primary vehicle hatch is large and slow to open. The intruders will immediately spot it and open fire. The SK-5 is proof versus their small arms and the bandits have used up all of their dynamite trying to blow in the roof.

If the Team chooses to run, they can escape with their autonav and vehicle intact but with no weapons or radios mounted. The bandits will happily watch them leave, loot the bolthole and flee. If the Sheriff and Rusty are both killed, their surviving men will flee.

Both the Sheriff and Rusty know that a second MP team outside Cloverton ("another bunch of buried folk") are being dug up by Blackshirts from New Manhattan. They don't know how many Blackshirts are involved, but they do know that they'll take the Team and all its gear and interrogate them before heading back to New Manhattan. Most likely, they'll go to old Fort Bundy to perform their interrogations in comfort. Fort Bundy, located on the map near where Cloverport used to be, has most of a company of infantry assigned to it (see Fort Bundy section).

If the Team leaves the area without talking to their "visitors," they will usually travel one of two directions along the River. Obviously the PD wants them to travel towards Fort Bundy. Usually this is no problem as most Team's head straight for the Science bolthole and the encounter described below.

If for reasons unknown they do not go to the Science Team bolthole, the PD can have the Team's radio operator pick up the scrambled radio signal from the SF team left behind at the Science Team's bolthole. This usually intrigues the Team enough to keep them listening. After enough time has passed, they will be able to get a fix on the transmission and can follow it back. The MARS Team leader will immediately recognize the location and so, if the Team is bright enough to pound sand, they will approach the bolthole carefully.

PDs Note: Since the Free State has radio and television transmissions, the Team will pick up more than just the stay-behind SP team's transmissions. The interesting thing about the SP team's transmission is that it is scrambled and that it is not scrambled using the Morrow Project scrambler. In the meantime the Team can build up a loose impression of the Free State by listening to their radio. Remember, unless the Team has talked to Rusty Hawkins or Booker T. at some length they will probably not know that 150 years have passed.

At the Science Team Bolthole

The Secret Police troops assigned to this mission are well trained professionals. They blew open the main hatch and captured the entire Science Team in their cryotubes. Their jubilation at capturing a Science Team, complete with vehicle, was short lived when they discovered that even with the Team's own captured ID cards the systems on the Science One didn't work. Loading the captured gear and their prisoners into their vehicles, they took everything back to the Fort where things could be sorted out at leisure.

Behind them, they left a four man team. The team consists of a lieutenant, corporal and two privates with a CETME and a backpack radio. They are set up to watch the Science Team bolthole to see if any other MP personnel appear to investigate. If the player's team shows up, the watchers will radio Fort Bundy via scrambled transmissions while staying hidden. They will not start a firefight. Fort Bundy's response will be to go on full alert and call in reinforcements, up to and including an airstrike if they get wind of the SK-5. They'll get it too. Awake and operating MP Teams in the Free State are considered serious business.

However, the SP team has lousy fieldcraft. Any reasonably cautious approach on foot will spot the ambush team before they spot the MP Team. In addition to the CETME and radio, they have three Mini-14s, two HEAT rifle-grenades and a dozen M26 fragmentation grenades. All three enlisted men wear MP resistweave coveralls died black. The officer is wearing resistweave coveralls covered in a camouflage pattern and E-factor 10 Kevlar panels placed over both thighs. In addition, he has a Kevlar vest.

The SP team makes hourly radio checks with the detachment at Fort Bundy. If they do not make a radio check, one of the SP V-300s with two SP men and eight Army troops will be sent to investigate. If taken prisoner, the SP men will not stand up to any interrogation. Like most secret police, they are solely concerned with their own survival. The Lieutenant will hold out the longest, but will also crack fairly easily. They know that the Science Team is being taken back to Fort Bundy for interrogation and can give detailed information on the number of troops in the Fort, its layout and the weapons available. With this information, the Team should be able to decide what to do next.

Back At The Fort

If the Team decides to knock on the Fort's front door they are in for a rough time. While they have enough firepower and mobility to raid an unalerted Fort, there is no way they can get the SK-5 up to the Fort without alerting the Fort to their presence. In order to get from the River to the Fort they must: 1. Go into Portown or some similar place where the bluff on the south side of the River has a break. 2. Travel up the road to the Fort

at minimum speed so as not to flip the SK-5 (see the discussion of hovercrafts in the *Team Equipment* section).

This will attract attention. A lot of it.

Once this happens, the jig is up. An alert Fort cannot be successfully raided. There is too much firepower, and too many people for a lone team to take on. The machineguns in the Fort's towers can sweep the River for most of the way along the loop to the north and the loop to the east effectively interdicting this bend in the River. Even the SK-5, travelling as fast as it does, can be destroyed if it comes under fire within 1 km of the Fort. At that range the gunners will be able to put enough rounds into it to sink or at least damage it to the point where it will need to be landed quickly. At longer ranges its a matter of luck to hit and if a trooper firing at longer ranges hits, it is likely to be serious but not disastrous.

This means that the Team must dismount and approach the Fort on foot. Not a pleasant idea, but probably for the best anyway. A gung-ho attack on the Fort probably would have resulted in the death of the Science Team.

If they have good intel from the (hopefully) captured stay-behind team, they should be able to get a rough idea of the Fort's layout and where the Science Team is kept. From there they could use the demo charges they've got to blow a hole in a wall of the Fort ("Knock-knock, anybody home?"). This was a favorite approach with some of the playtest groups.

The problem with this is that to succeed they will need to: 1. Dismount from the SK-5 a reasonable distance away. 2. Approach the Fort without anyone noticing. 3. Place the charge, again without anyone noticing. 4. Blow the hole. 5. Rush in under cover of the confusion caused by the explosion. 6. Find the Science Team members. 7. Shoot or disable their captors without harming the captives. 8. Get the Science Team out of there while the defenders rush about looking for someone to shoot. 9. Get back to the SK-5 (presumably in the dark) while hastily organized patrols comb the area for them. Sounds like a good movie but I don't think it'd work in real life.

One possible option is to use civilian clothes captured from the intruders to get into one of the taverns outside of the Fort. If they can identify Cassie Tucker as a friend, and she decides they are trustworthy, she can smuggle gear into the Fort.

In any event, she will report their presence to her cellmates in the Children of Liberty and it may be that the Snake Eater team can be brought into the action if the Team is lucky.

If the Team attempts to use the SP uniforms from the stay-behind group at the Science bolthole they will briefly have free run of the Fort since none of the regular soldier would question an SP trooper. Of course all of the SP team members will immediately



recognize the MP people as being phonies and as soon as they encounter them, the alarm will go up.

But such a group may be able to either get into the Science One vehicle or into the Stockade before the they are detected (at least three people have the 12-digit code - the MARS leader and two Science Team members). In the successful playtests, some variation of this combined with an attack on the Fort with as much firepower as can be carried up the hill worked best.

In some cases the Team brought the SK-5 up the hill after the fighting began. The SK-5 *is very fast* once it gets up the hill. In others they brought what they could up by foot and then either got into the Science One as it left or returned to the SK-5 before patrols could go out.

If the Team can rescue the Science Team members and get them into the Science One, then they should be able to get out before effective resistance can be organized. However, this is only possible if the Fort was not alerted

Repeated attempts by the MARS Team to contact the Science Team by radio will alert the SP to the existence of the MARS Team. One attempt will be brushed off as someone clowning around on the radio. If the SP stay-behind team at the Science bolthole gets off its message, the Fort will again be alerted and ready.

Once alerted, the Fort will put two platoons of troops on the walls, all of whom will be loaded for bear while the rest of the troops will have loaded magazines and full weapons issues. The SP detachment will have both the V-300s manned with the balance of their troops on the roof of the stockade, armed with the best of the weapons taken from the Science One. If this occurs

and the Team attacks or attempts to infiltrate the Fort they will be lucky to escape with their lives.

In playtest, no one who faced an alerted Fort survived. In this case the best chance to rescue the Science Team will be to wait until the SP move them to New Manhattan. Of course, by this time the SP will have gotten all the information out of the Science Team that they need, probably at the expense of one or two dead or worse. And of course the Science One vehicle will be in the hands of the SP so the Team will need to deal with it. Any attempt to ambush them will be extremely tough, particularly if the Team wants to not kill the Science Team members.

If the MP Team does not rescue the Science Team on the first night, they will be broken by the SP. The Science personnel are not cowards. They are, however, tired and disoriented. Further, the SP are skilled and ruthless interrogators. By dawn one of the Science personnel will have broken and given the SP the lockout code for the Science One. In this event, the next morning the SP detail will leave for their headquarters with the two V-300s and the Science One with all its weapons stations armed and manned.

If the Team plans to try and ambush the group as it heads for New Manhattan, the Project Director may want to provide some outside help in the form of the Children of Liberty or possibly a Snake Eater team. Of course if the Team has played badly, then they deserve the trouble they've stirred up and the PD can let them stew about it until the reinforcements from the Free State start searching for them.

One way or another, the fact that there is a loose Morrow team running around will become apparent. When this happens the SP will call for reinforcements (which they will get) whose mission will be to comb the countryside for the Team.

The Team will have to decide what to do next. Standing and fighting is suicide. The entire remaining strength of the Third Regiment will be called out against them once word gets out while the Free State's air force will begin searching for them and once they are found (as they will be if they stay in the vicinity), they will begin overflying the Team and strafing them. The Seventh Regiment (Praetorians) will be mobilized and sent after the Team if they last more than twelve hours. The Free State takes loose Morrow teams as very serious business.

The Team may abandon their vehicles and hide, but inside of a day the woods will be alive with Army troopers. Their only viable option is to run, far, fast and long. Doing so with the Science One is dubious. The best approach is to abandon it, destroying it before leaving.

From Fort Bundy heading north is simple. Once across the River, if the Team continues to head north they will probably only have to worry about aircraft. Once farther than 45 kilometers from the Free State the

pursuit will be abandoned (though the Free State will alert spies in the area north of the River to keep an eye out for them).

Within the near vicinity of the Free State they will continue to be attacked with steadily increasing force as long as they can still fight. If the Team continues to evade pursuit, then the chances of rain in the area increases as the Ohio River valley is prone to heavy rainstorms at this time of the year. This will aid the Team's escape as such rain is likely to ground all airplanes and make them even more difficult to follow.

This is unusual in MP modules in that it has an extremely specific mission as well as immediate contact with another MP Team. A mix of caution and daring is called for if this adventure is to be successfully played.

Soldiers on duty day-after-day, without any visible enemy get bored. Security tends to relax. This is one factor that gives the Team a chance. But make no mistake: The Free State army is not some gang of bandits with guns, it is a real army, with real soldiers, real artillery and air support and real armor. Wiping out one unit only means that another will come along, probably a stronger one.

DESIGNER'S NOTES

Bullets and Bluegrass continues the series of Morrow Project modules set in the Midwest. In this case it involves a strong, politically intact area with an organized army and a high level of industrial production.

In early playtest versions it was a straight firefight where the Team drove the SK-5 up to the Fort and did as much damage as possible as quickly as possible.

Too many times the Science Team died. So we adjusted the scenario to make it obvious that only a fool would try such an approach - a dead fool. As it currently stands it is a challenge - the players must think and plan carefully or not only are the Science Team members not going to be rescued, but the MARS Team will die or be captured. This is why we test our modules so extensively.

While the players may not realize it at first, The Kentucky Free State poses a unique problem for The Morrow Project. The knee-jerk reaction of most players once the Science Team has been rescued is to join the Underground in the struggle to overthrow the Free State.

There are a lot of good reasons to do this: slavery, the relative poverty of 90% of the population of the Free State, the Free State's systematic hunting down of Morrow Project teams and their total lack of interest in restoring the United States to what it was. But overthrowing the current regime will only happen after a long and bloody struggle. It may call for the destruction or sabotage of much of the industrial

capability of the Free State and it will certainly call for a lot more deaths.

There are not a lot of lives to spare in 22nd Century America, and the Morrow Project does not have the might to overcome the Army of the Free State on its own.

What is to be done?

Certainly the Project cannot sit back on their hands and allow things to continue as they are. With Prime Base back on-line (see PF-08, Prime Base for details) the Morrow teams once again have some centralized control and direction. But Prime Base does not have resources to spare and is a long way from the situation. They can provide technical information and coordination via long-distance communications and the Morrow satellite which has recently been launched (see **PF-06, Operation Lonestar**). But they cannot solve the problem. They have no magic wand.

If the Team escapes the immediate pursuit from the Free State, they will probably come into contact with the units of the Underground operating on the north side of the River. The alliance of the Underground, the Morrow Project and the Snake Eaters is on the spot and will have to judge what is the best course of action in dealing with the Free State. It is up to your players and you, the Project Director, to decide what happens next in the ongoing struggle.

Certainly a powerful enough force could cow the Free State into negotiating their position. But there is no such force at the moment. The struggle of the Underground will be long and arduous. Many people will die, many people will fall into the hands of the Secret Police.

The people of Starnaman (see PF-05, The Starnaman Incident) and the similar independent towns along the Mississippi will not join the struggle unless the Free State attacks them. It is none of their business. They will trade with the Underground and will offer safe haven for fleeing slaves or teams, but unless directly threatened they will have nothing to do with the upcoming struggle.

However if the Underground gets definitive proof that the Free State is about to "annex" the land between the Tennessee River and the Mississippi, then this would involve the independent towns. The problem is making them believe this is going to happen. The Team might be sent as part of a representative group to the town of Starnaman to present the case for an alliance.

MARS Team K-98 with the powerful and extremely mobile SK-5 can be a great aid for isolated raids but the proposed struggle against the Free State is more one of infiltration and propaganda, less of pitched battles. One job that may need to be done immediately is to ensure the destruction of the Science One vehicle if it survived the raid which freed the Science Team. The technology and information in it would be of great

value to the Free State scientists and the added information it would give them about the Morrow Project could be disastrous.

Similarly, there is the issue of the other sleeping teams. While Prime Base cannot awaken them (see page 33 of **Prime Base**), or even tell the Underground exactly where they are, the resistance has made it a practice to monitor the Free State's communications where possible to find out about awakened or captured teams. It was because of this that a mixed Morrow-Snake Eater team was on the north side of the River during the escape from Fort Bundy. The Team, with their mobile vehicle and powerful strike capability may find themselves detailed to help other teams escape from the Free State.

Then there is the call from Prime Base. The Team, once in contact with the other operating teams, will be told about the call to the Snake River valley described in **Prime Base**. After having the situation sketched out to them, the Team may be offered the option of heading out as an escort for a group of settlers. Of course the SK-5 would not be practical for such a trip, they will probably have to trade it in for another vehicle, or even go on foot (after all, the Underground is going to need everything in the way of muscle they can get).

Whatever happens, the Free State is a problem which is not going to go away in a hurry. In the long run, the best solution would be to include it in a rebuilt American Republic which would be closer to the confederation before the passage of the Constitution. Of course, the Free state would have to give up notions of slavery, serfdom, bondsmen, etc., something they are not likely to do without the influence of extreme pressure.

In any case, Team K-98 is not lacking in challenges. There is work for any team willing to shoulder the burden of The Morrow Project.

Good Luck!



NEW EQUIPMENT

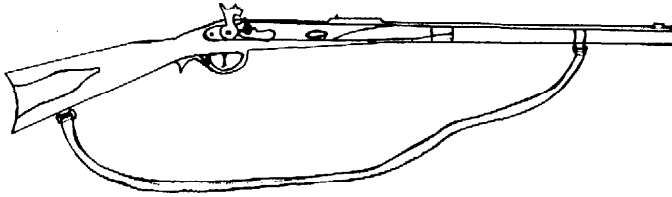

| | |
|---------------------|---------------------------------------------|
| Name: | Trade Rifle |
| Caliber: | .40 |
| E-Factor: | 14 (with Mine ball) 11 (with round shot) |
| Weight (Empty): | 6kg. |
| Effective Range: | 300m. |
| Maximum Range: | 850m. |
| Type of Fire: | Single Shot |
| Rate of Fire: | 1 1/2RPM |
| Feed Device: | None |
| Feed Device Weight: | N/A |
| Basic Load: | 60 rounds |
| Load Weight: | 2.7kg. |
| Total Weight: | 8.7kg. |

One of the most popular items of trade on the River is the Trade Rifle. It is a double-action, cap and ball rifle. Built by the Hunter industrial combine, it has provision for mounting a spike bayonet. A reliable weapon built for simplicity, it has a maximum effective range of 500 meters. By post-holocaust standards it give the user awesome firepower and is the weapon of choice among overlords and bandits along the rivers.

The Free State sells these because they are slow to reload, popular trade items and cheap to manufacture. Further, the Free State controls the ammunition supply for these weapons and so to some extent can control just how much firepower its neighbors accumulate. Any political unit on the River that tries to manufacture its own caps soon have to face a few regiments of Janissaries.

PD Note: The Trade Rifle is manufactured from soft steel and is not blued. Though a good design, any given trade rifle has a useful lifespan of about ten years. The Free State wants it that way and does not sell spare parts or extra barrels for the weapons though Janissary units will have them.

| | |
|------------------|-------------------------------|
| Name: | NICO "Thunder-flash" grenades |
| Weight: | .25kg |
| Effective Range: | 40 meters |
| Fuse Delay: | 2.5 seconds |
| Basic Load: | 2 |
| Load. Weight: | .5kg |
| Packaging: | 16 per case |
| Package Weight: | 17kg. |

Effects: This grenade creates eight randomly timed "thunderflashes" each of 175 decibels and generating two and a half million candlepower of light. Any person within 10 meters of one of these grenades when it goes off will be stunned, blinded and helpless for one minute afterwards, deafened and operating at 1/4 their normal skill level for five minutes after that. The body of the grenade is waterproof cardboard to ensure no fragmentation while the explosives themselves are almost entirely flash and bang and unlikely to harm anyone physically.

FREE STATE ARMY WEAPONS

Twenty years after the War, as their scavenged or preserved weapons wore out, the Free State realized it would need to manufacture its own small arms and, eventually, its own weapons. Prewar designs of proven ruggedness, simplicity and reliability were chosen. In a counterpoint to the comparatively simple workmanship of the Trade Rifles, these weapons are made to extremely high standards and most Free State troops carry weapons that are twice as old as they are.

Most of the weapons manufacture in the Free State is still based around the factories built in or near their mountain hideout, a fact which has made it difficult for the Underground to successfully sabotage them.



| | |
|------------------|---------------|
| Name: | Ruger Mini-14 |
| Caliber: | 5.56mm x 45mm |
| E-Factor: | 15 |
| Weight (Empty): | 15kg. |
| Effective Range: | 500m. |
| Maximum Range: | 2,653m. |
| Type of Fire: | Selective |

Rate of Fire: 40/120rpm
 Feed Device: 40 round magazine
 Feed Device Weight: .565kg
 Basic Load: 5 magazines,
 200 rnds
 Load Weight: 2.825kg.
 Total Weight: 5.715kg.

The Mini-14 uses the gas action of the old M-1 Garand, mated to the 5.56 NATO round. The version used by the Free State has a flash suppressor, bayonet lug and grenade launcher mounted on it. It is capable of firing full or semi-automatic and a folding stock version is issued to officers and armor crewmen. It is an extremely rugged and reliable weapon, simple to use and maintain.



Name: CETME Squad Automatic Weapon
 Caliber: 5.56 x 45mm
 E-Factor: 14
 Weight (Empty): 6.94kg.
 Effective Range: 700m.
 Maximum Range: 2,650m.
 Type of Fire: Full Automatic
 Rate of Fire: 1200rpm
 Feed Device: 150 rnd belt
 Feed Device Weight: 1.95kg.
 Basic Load: 6 belts (900 mds)
 Load Weight: 11.70kg.
 Total Weight: 18.64kg.

The Free State chose the CETME as their standard machine gun for the same reasons as they chose the Mini-14. It is simply, rugged and reliable. A modification of the World War II German MG-42, it is a Spanish design chambered in 5.56 x 45mm. The weapon has an extremely high rate of fire for a light machinegun. Short bursts from it are 10 rounds, medium 20 rounds, long 30 rounds. This is one reason for the very large basic load.

In the field, the CETME gunner usually carries one 150 round box loaded and a second box of ammo open and ready. The other four boxes, still closed, are carried by other members of the squad. The cardboard ammo boxes issued with the ammo come in cloth covers with straps that fit over hooks on the feed tray.

This eliminates the need for a loader while keeping the links from dangling loose and picking up dust, leaves or twigs which might feed into the weapon and jam it.



Name: Smith and Wesson Model 59
 Caliber: 9x19mm
 E-Factor: 9
 Weight (Empty): .85kg.
 Effective Range: 50m.
 Maximum Range: 2012m.
 Type of Fire: Double action, semi-automatic
 Rate of Fire: 42rpm
 Feed Device: 14 rnd magazine
 Feed Device Weight: .2kg.
 Basic Load: 3 magazines
 Load Weight: .6kg.
 Total Weight: 1.45kg.

The S&W Model 59 is a 9mm double action pistol that was Smith and Wesson's entry into the competition for a new sidearm to replace the M1911A1 .45 caliber pistol. The Free State copies it for use as an officer and NCO sidearm, as a weapon for pilots and tankers and as the standard sidearm for its sheriffs. As a double action pistol, it can safely be carried with a 15th round in its chamber.

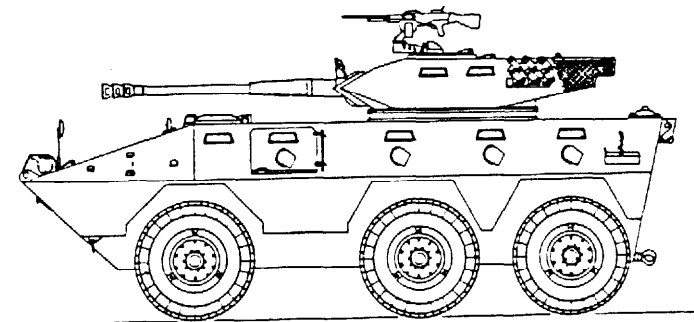

Cadillac Gage V-300 with 90mm Cockerill Gun

The success of the V-150 Commando series inspired a larger version. The V-300 resembles a stretched V-150 with an extra set of wheels. The version copied by the Kentucky Free state mounts the two-man Cockerill 90mm gun turret, with four smoke dischargers and two 7.62mm machine guns, one mounted coaxially with the main gun, the other mounted on top of the turret for anti-aircraft work.

In Free State usage, each vehicle usually has a three man crew plus four "tank marines" (infantry). One of the infantrymen usually remains with the vehicle using the TC (track commander's) gun while the TC operates the 90mm and the coaxial gun.

The V-300 is fully amphibious, can be sealed against NBR threats and is exactly the same armor class as the standard V-150. Like all other vehicles used by the Free State, the V-300 uses a multifuel rotary engine which can use any flammable liquid for fuel. Kerosene, gasoline, diesel, ethyl or methyl alcohol, high quality liquor or even perfume can be used in these vehicles. The normal fuel is either diesel or ethyl alcohol.

Data on the V-300 is as follows:

| | |
|--------------------|-----------------------------------------|
| Name: | V-300 |
| Crew: | 3+9 (max.) |
| Length: | 6.4m |
| Width: | 2.54m |
| Height: | 2.7m |
| Ground Clearance: | .381 m |
| Turning Radius: | 10m |
| Max. Road Speed: | 92kph |
| Water Speed: | 5kph |
| Gradient: | 60% |
| Vertical Obstacle: | .609m |
| Trench: | .5m |
| Armor Class: | 120 |
| Armament: | 90mm Cockerill, 2 x 7.62 machineguns |
| Ammunition: | 36 rnds - 90mm 3200 rnds - 7.62mm |

The most common 90mm round is an HE round with an anti-armor class of D. Other rounds include HEAT (Anti-armor: C) and WP-smoke.

Free State Rifle Grenades

Based on the designs of 22mm tail rifle grenades designed in the 20th century, the Free State Army rifle grenades are of the "bullet catcher" design. Simply put, they fit over the standard flash suppressor of a Free State Mini-14 and the grenadier then fires a single round of 5.56 which lodges in a pocket in the base of the grenade, arms it and carries it on a long, looping trajectory.

Should the operator have his rifle set on full automatic, the stream of bullets will strike the grenade in flight, detonating it less than five meters from the firer. In other words, there is no minimum arming range for these grenades.

There are four different types of rifle grenades used by the Free State: HE, White Phosphorous and Illumination. The SP also carry an HEAT round for use against the Morrow Project. HE has a DPW of 314, a burst radius of 4 meters and scatters E-factor 4 shrapnel in a 15 meter circle from the point of detonation. The WP grenade is for smoke/incendiary purposes, has a burst radius of 40 meters and a DPW of 110. The Illumination is a parachute flare which illuminates an 80x80 meter area for 20 seconds. The HEAT is limited to anti-armor work and is of Anti-armor class E and has a maximum range of 180 meters.



NON-PLAYER CHARACTER STATISTICS

Fort Bundy NPCs

Secret Police Detachment

Major John Paul Getter

| | | | | |
|---------------|------------------|-------------|-------------|------------|
| Strength: 14 | Hand to Hand: 15 | Handgun: 45 | Rifle: 25 | SP/BP: 296 |
| Dexterity: 16 | Martial Arts: 20 | SMG: 35 | Saber: 35 | |
| Intell: 16 | Charisma: 13 | Lawyer: 65 | Movement: 4 | |
| Height: 6'2" | Weight: 1671 bs | Hair: Brown | | |

Captain Barnard "Skip" Hughes

| | | | |
|--------------|--------------------|---------------|----------------|
| Strength: 10 | Special Weapon: 30 | HGun: 45 | SP/BP: 180 |
| Intell: 9 | Dexterity: 11 | Height: 5'11" | Weight: 215lbs |
| Age: 38 | Movement: 3 | Hair: Black | |

Lieutenant Trent Donfeller the Third

| | | | |
|------------------|----------|------------------|------------|
| Strength: 14 | SMG: 40 | Hand-to-Hand: 10 | SP/BP: 296 |
| Dexterity: 19 | HGun: 40 | Martial Art: 30 | Move: 4 |
| Intelligence: 17 | Luck: 6 | Hair: Blonde | |

Sergeant First Class Clayton Hutch

| | | | |
|------------------|-----------|------------------|------------|
| Strength: 18 | HGun: 60 | Hand-to-Hand: 45 | SP/BP: 370 |
| Intelligence: 14 | SMG: 40 | Martial Art: 30 | Move: 4 |
| Hair: Blonde | | | |
| Dexterity: 14 | Rifle: 65 | Knife: 70 | Luck: 8 |

Standard Secret Service Trooper or NCO

| | | | |
|-----------------|-----------|------------------|------------|
| Strength: 12 | SMG: 25 | Hand-to-Hand: 20 | SP/BP: 244 |
| Intelligence: 9 | Rifle: 20 | Handgun: 30 | Move: 3 |

Army Garrison

Major Thomas Carstairs the Fourth

| | | | | |
|-----------------|-------------|------------|---------------|------------|
| Strength: 10 | Handgun: 45 | Lawyer: 65 | Height: 5' 7" | SP/BP: 180 |
| Intelligence: 9 | Rifle: 35 | Age: 42 | Weight: 200 | |
| Dexterity: 9 | Saber: 60 | Move: 3 | Hair: Red | |

Captain Palmer

| | | | |
|-----------------|-------------|--------------|-------------|
| Strength: 12 | Handgun: 25 | Height: 6'5" | SP/BP: 244 |
| Intelligence: 8 | Rifle: 55 | Weight: 170 | Eyes: Brown |
| Dexterity: 11 | Move: 3 | Hair: Brown | |

Captain Taylor

| | | |
|-------------|--------------------|---------------|
| Medical: 70 | Intelligence: 17 | SP/BP: 250 |
| Knife: 55 | First Aid: 90 | Dexterity: 19 |
| Handgun: 20 | Veternary Med.: 65 | Move: 5 |

Leutenant Vanderbill

| | | | | |
|------------------|-------------|------------------------|--------------|------------|
| Strength: 15 | Rifle: 25 | History (Military): 35 | Height: 5'6" | SP/BP: 325 |
| Intelligence: 16 | Handgun: 50 | Saber: 60 | Weight: 157 | |
| Dexterity: 17 | Move: 4 | Martial Arts: 35 | Hair: Brown | |
| Char.: 15 | Shotgun: 35 | Hand-to-Hand: 24 | Age: 24 | |

Leutenant Takeda

| | | | |
|------------------|-------------|------------------|-------------|
| Strength: 14 | Rifle: 25 | Height: 5'8" | SP/BP: 240 |
| Intelligence: 14 | Handgun: 40 | Saber: 60 | Weight: 172 |
| Dexterity: 17 | Move: 4 | Martial Arts: 35 | Hair: Black |
| Shotgun: 30 | | | |

1st Sergeant Clalbourne

| | | | | |
|------------------|------------------|------------------------|--------------|------------|
| Strength: 17 | Rifle: 55 | Knife: 85 | Height: 6'0" | SP/BP: 355 |
| Intelligence: 14 | Handgun: 40 | Saber: 60 | Weight: 195 | |
| Dexterity: 15 | Move: 4 | Martial Arts: 35 | Hair: Grey | |
| Shotgun: 30 | Hand-to-Hand: 70 | Crew Served Weapon: 35 | | |

Typical Enlisted Man

Rifle: 35 Bayonet: 25 Strength: 13 SP/BP 230
Intelligence: 10 Handgun: 20 Saber: 60
Hand-to-Hand: 25 Crew Served Weapon: 30

Typical NCO

Rifle: 45 Knife: 40 Hand-to-Hand: 35 SP/BP: 253
Intelligence: 13 Handgun: 35 Bayonet: 45
Move: 3

Typical Officer

Rifle: 30 Knife: 25 Hand-to-Hand: 15 SP/BP: 220
Handgun: 45 Bayonet: 15 Shotgun: 40

OTHER NON-PLAYER CHARACTERS

Loomis Suggs

Strength: 17 Knife: 55 Handgun: 35 Shotgun: 40
SP/BP: 335
Dexterity: 12 Height: 6'7" Weight: 380lbs Move: 3

William Tucker

Strength: 10 Handgun: 25 Cooking: 75 SP/BP: 200
Intelligence: 9 Height: 5'8" Weight: 160lbs
Dexterity: 17 Move: 4

Cassandra Tucker

Strength: 12 Knife: 25 Rifle: 35 Handgun: 35
SP/BP: 280
Intelligence: 15 Height: 5'4" Weight: 120lbs Hair: Black
Dexterity: 17 Political Science: 65 Economics: 45 Move: 4

Gordon Baker

Strength: 20 Hand-to-Hand: 70 Knife: 40 SP/BP: 400
Intelligence: 5 Height: 6'4" Weight: 275lbs
Dexterity: 10 Move: 3

**BACK
BY
POPULAR
DEMAND!**



PF-05

**THE
STARNAMAN
INCIDENT**

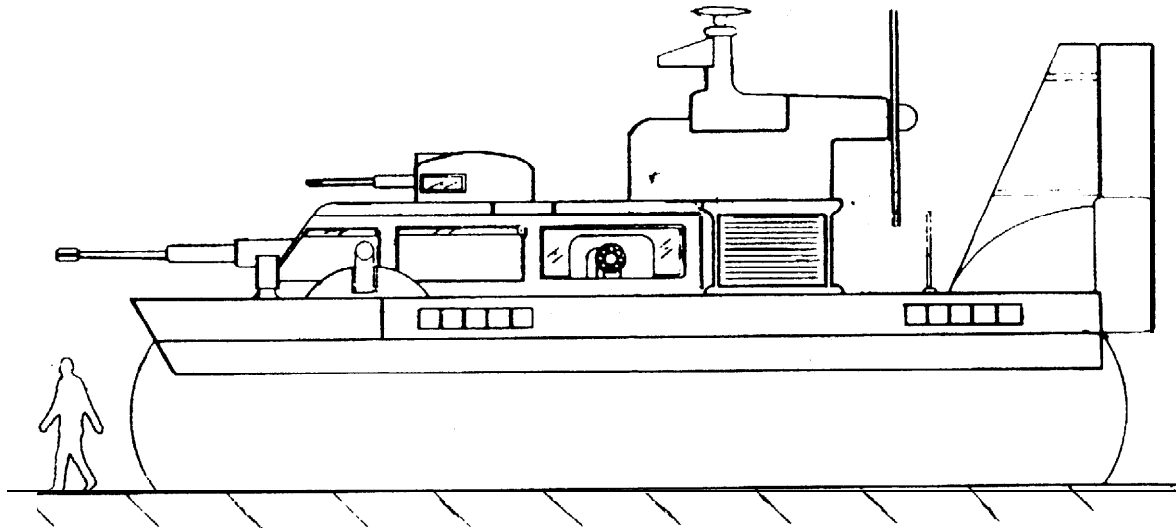

When MARS Team K-98 wakes to their bolthole alarm, they know they must act quickly or die. They face an awesome challenge against a well-equipped foe to rescue their comrades from death and worse. To make it *hard*, the hostages are kept in a secure spot which they must find and break into before its too late. Can they do the job before they are discovered and hunted down by a merciless enemy?

This game package contains all of the information, maps and systems necessary for the Project Director to run this scenario. It also includes information on new weapons, the SK-5 hovercraft, detailed cache contents and more.

**POSSESSION OF THE MORROW PROJECT
GAMEBOOK IS NECESSARY TO THE USE OF THIS
GAME PACKAGE.**