

# EPSILON CITY

METAMORPHOSIS ALPHA



By James M. Ward  
And Jobe Blittman, Michael Curtis,  
Jon Hoek, and Jim Wampler

# EPSILON CITY

BY JAMES M. WARD AND  
JOBE BITTMAN, MICHAEL CURTIS, JON HOOK, AND JIM WAMPLER

COVER ARTIST: JIM HOLLOWAY • ART DIRECTION: JOSEPH GOODMAN  
CARTOGRAPHER: TOM DENMARK • GRAPHIC DESIGN: JAMIE WALLIS  
EDITOR: JEFF ERWIN • INTERIOR ARTISTS: JIM HOLLOWAY, WILLIAM  
MCAUSLAND, BRAD MCDEVITT, AND STEFAN POAG.

METAMORPHOSIS ALPHA CREATED BY JAMES M. WARD



[www.goodman-games.com](http://www.goodman-games.com)  
[www.metamorphosisalpha.net](http://www.metamorphosisalpha.net)

METAMORPHOSIS ALPHA is a trademark of  
James M. Ward and is used with permission.  
This volume is copyright 2016 Goodman Games.



# TABLE OF CONTENTS

|  |     |   |     |
|--|-----|---|-----|
| Introduction.....                        | 3   | Sky Roof Section .....                            | 148 |
| What is Metamorphosis Alpha? .....       | 4   | Bestiary .....                                    | 149 |
| What is Epsilon City? .....              | 4   | Creatures of the Adventure .....                  | 149 |
| <b>A2 Asgard Apartment Complex</b>       |     | <b>A65 The Attila Arms Apartment Complex</b>      |     |
| The Viking Wolfoid Apartments .....      | 14  | The Hun Wolfoids.....                             | 153 |
| The Asgard Complex .....                 | 15  | The Attila Arms Apartments .....                  | 155 |
| level 1: Main Floor.....                 | 18  | Level 1: Main Floor .....                         | 156 |
| level 2: Empress Floor .....             | 24  | Level 2: Empress Floor.....                       | 161 |
| level 3: Vista Floor.....                | 28  | Level 3: Vista Floor.....                         | 165 |
| level 4: Lido Floor .....                | 32  | Level 4: Lido Floor .....                         | 168 |
| level 5: Sky Floor.....                  | 36  | Level 5: Sky Floor .....                          | 174 |
| Appendix A: New Tech.....                | 38  | <b>A87 The Hotel Warden</b>                       |     |
| <b>A18 Egyptian Complex</b>              |     | Introduction.....                                 | 177 |
| Background.....                          | 39  | Level 1 – Managerial and Admin level.....         | 184 |
| The Perimeter and General Information .. | 41  | <b>Olympus Sports &amp; Entertainment Complex</b> |     |
| Main / Ground Floor .....                | 44  | Description.....                                  | 212 |
| Area A-1: Entering the Egyptian Complex  | 44  | Area 1: The Entrance Hub .....                    | 217 |
| Second Floor .....                       | 54  | Area 2: IEE Suites.....                           | 225 |
| Third Floor .....                        | 62  | Area 3: The Stadiums.....                         | 230 |
| Fourth Floor .....                       | 66  | Area 4: Operations Hub .....                      | 245 |
| The Roof .....                           | 70  | <b>Camelot Entertainment Centre</b>               |     |
| <b>A36 The Cherokee Nation Complex</b>   |     | Camelot Park in the Early Warden.....             | 254 |
| Background.....                          | 72  | Camelot, the Entertainment Center.....            | 258 |
| The Perimeter and General Information .. | 73  | Camelot Entrance Quest #1 .....                   | 262 |
| Main / Ground Floor .....                | 73  | Camelot Entrance Quest #2: .....                  | 263 |
| Tsul ‘Kalu Gulch .....                   | 85  | King Pellinor and the                             |     |
| Third Floor .....                        | 90  | Questing Beast: Quest #3 .....                    | 264 |
| Cherokee Nation Complex Apartments ....  | 92  | Gray Knight Android #4 .....                      | 264 |
| Fourth Floor .....                       | 96  | Forest of Mystery: Entrance #2.....               | 265 |
| The Roof .....                           | 102 | Stonehenge: Entrance #3.....                      | 266 |
| <b>A54 Roma Complex</b>                  |     | Stonehenge Quest D .....                          | 267 |
| Introduction.....                        | 103 | Stonehenge Quest E .....                          | 268 |
| Artificial Gods.....                     | 104 | Camelot’s Loch .....                              | 269 |
| Exploring Roma.....                      | 108 | Leaving the Park .....                            | 272 |
| Bestiary .....                           | 121 |   |     |
| <b>A60 Pirate Apartments</b>             |     |   |     |
| General Notes on the Pirate Complex..... | 126 |   |     |
| Main Floor .....                         | 129 |   |     |
| Empress Floor .....                      | 135 |   |     |
| Vista Floor.....                         | 140 |   |     |
| A – Lair of the Orange Wolfoids.....     | 140 |   |     |
| Lido Floor .....                         | 144 |   |     |

## INTRODUCTION

This product is designed to be run with any set of METAMORPHOSIS ALPHA rules. It presents a part of the starship *Warden*, namely Epsilon City, the centrally located residence complex. Epsilon City was designed to be entertaining as well as accommodating. The community had many amusement areas and each apartment complex had some type of diverting theme for everyone living in the apartment.

Epsilon City wasn't even half full, three hundred years ago, when the radiation cloud destroyed the people of the ship and turned 99% of them into piles of white ash. While there were separate entertainment centers, each apartment complex and office space was themed differently, often focusing on dramatic periods in Earth's history. The city was designed to be maintained by its own artificial intelligence (A.I.), autonomous from the ship's, and a special series of robots able to maintain areas of the city when breakdowns happened.

When the city turned on, while the ship was at the Plutonian starship yards, the plan was to allow it to be eternally repaired by special robotic systems dedicated for use only in the city. Each apartment and office had its own replicators so that food and the necessities of life were supplied free for the inhabitants of the apartments.

Three hundred years later, things are vastly different in the city. The central City A.I. is insane and has an aggressive personality. The special robots have had to adapt or be destroyed, and have undergone dramatic changes much like the mutated life elsewhere on the ship. Wolfoid packs now inhabit many sections of the city and consider this metropolis their lair.

-James M. Ward, The Winter of 2015

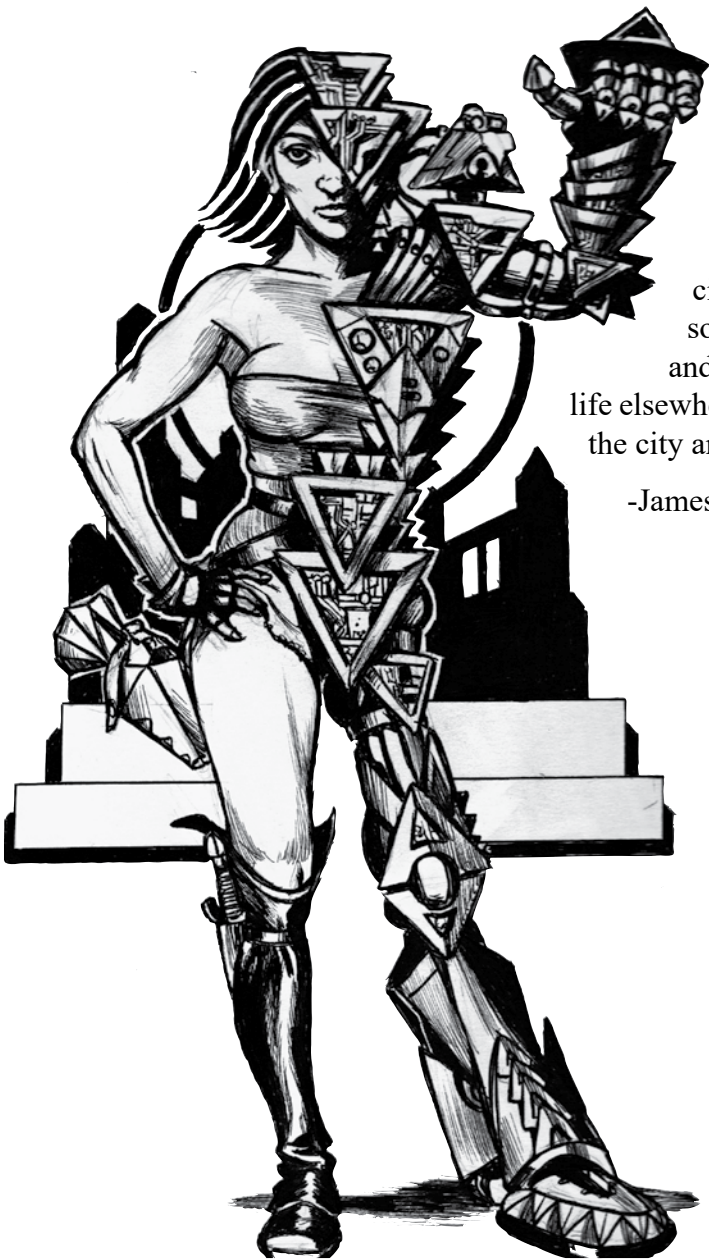

## WHAT IS METAMORPHOSIS ALPHA?

**A *Metamorphosis Alpha* introduction for those who don't know what it is:**

*Metamorphosis Alpha* is the first science fiction role-playing game. Coming out in 1976, it has stood the test of time; now there are five different versions of the game in print. In this role-playing experience you explore a lost colonization starship. A tragic event has thrown the ship far off course and killed 95% of the human crew and colonists turning them into piles of white dust.

Three hundred years later, the ship is still wandering unmoored and aimless in deep space. Many of the creatures that were brought with the ship have mutated into intelligent beings and even some of its plants have become self-aware, strange and deadly, or both. Most of the intelligent beings now living on it don't realize they are on a space ship 50 miles long and thirteen miles wide. The *Warden* is now their entire universe.

Can you make a difference and put the *Warden* back on its proper track? Only time will tell...

## WHAT IS EPSILON CITY?

Now, for the first time ever, there is a detailed set of adventures for the unique city of Epsilon in the starship *Warden*, also known as Deck 14. This accessory provides Game Masters and players with years of fun discovering the streets, parks, and buildings of the city.

You'll find the original description of Deck 14 in the METAMORPHOSIS ALPHA rules. In *Epsilon City*, you'll discover for the first time the full dangers and discoveries that await your party should they venture into the ruined metropolis.

**NOTE: Material written in bold face type is meant to be read or paraphrased to the players when they come to the area described.**

The idea for a city level on the *Warden* was sketched in James M. Ward's original rules for the game, detailed in a single page map and key. This page is duplicated on the next page for your convenience. The detailed map of the city takes up the central rectangular section of the deck, but outlying structures and complexes are left to you, the Starship Master, to describe and place, as it was in 1976.

## MAP KEY AND OVERVIEW

### OUTLINE OF THE CITY

---

Epsilon City's roads are divided into north-south streets named for Solar System orbital bodies and east-west avenues designated by Roman numerals. North-south corresponds to port and starboard and east-west to aft or stern and bow; these terms are only used in historical materials and datafiles from before the Cataclysm. Present-day natives of the *Warden* rely instead on cardinal directions.

The planetary bodies go from west to east as follows: Mercury, Venus, Mars, Jupiter, and on the north side of the central park area, Phobos, Ganymede, Europa, Callisto, Caelus, Neptune, Calypso; and on the south side, Deimos, Titan, Hyperion, Janus, Pandora, before meeting again at Pluto, Charon, and Nibiru.

### MAP KEY

---

These are north/south buildings along Mercury and Venus streets. These buildings are designated for Game Masters to use and fill up as they wish. In game terms, unless you wish to change things, these are also empty buildings with still functioning technology:

A1, A15, A29, A38, A47, A52, A57, A62, A71, A82

These are east/west buildings along the IX and X avenues. These buildings are left to Game Masters to use and fill up as they wish. Like the buildings on Venus and Mercury Streets, these are also empty buildings with still functioning technology:

A71, A72, A73, O1, A74, A75, A76, A77, A78, A79, A80, A81

Wolfoid Complexes: the streets around these buildings usually have a squad of 3 wolfoids roaming each side of the building:

A2 is the Viking wolfoid apartment complex

A18 is the Egyptian wolfoid apartment complex

A36 is the Cherokee wolfoid apartment complex

A54 is the Roman wolfoid apartment complex

A60 is the Pirate wolfoid apartment complex

A65 is the Hun wolfoid apartment complex

A87 is the Hotel *Warden* complex

## EXAMPLE: LEVEL 14 (THE CITY SECTION)

This example illustrates a possible referee's conception of one level of the ship. This example shows some details of what might be included on this level; of course, different judges will portray such details quite differently.

### KEY

- 1) Medical Area with full medical facilities: thousands of beds, numerous operating areas, special recuperative facilities, biological experimentation station, offices, storage area for supplies and drugs, and living units for the medical staff. Emergency medical sleds are housed in the area (there are several) and a number of medical type robots are found in the facilities.
  - 2) Detention Area containing: monitored jail cells, cooking areas, offices, exercise and recreation areas, and a secure weapons storage facility.
  - 3) Bachelor Dwelling Area, with each individual unit including the following: living room, bedroom, bathroom, work room, large recreation room, closets and storage space.
  - 4) Family Dwelling Area, with each individual unit including the following: living room, several bedrooms depending upon number of family members, two bathrooms, three work rooms, a play room, recreation room, closets, and storage space.
  - 5) Schools Area containing: schools and technical institutes each with desk consoles, intership communications devices, offices, libraries of several types, work areas and equipment.
  - 6) Recreation Area featuring: parks and scenic attractions, gyms, pools and small lakes.
  - 7) Main Ship's Elevator
  - 8) Inclined Plane, connecting levels
  - 9) Theatre/Entertainment area including: numerous theatres of various types, multi-media studios, music and cultural buildings, sports arenas, etc.
  - 10) Dining Areas including: a myriad of restaurants featuring foods of all kinds and types.
  - 11) Office Area with individual units featuring: small and large compartmented rooms, desk consoles, filing cabinets and data storage computers, intership communications devices, etc.
  - 12) Rural Villages containing a relatively small number of family dwellings.
  - 13) Country Villas for large families with normal facilities, but spacious.
  - 14) Forests and Lakes, of varying size appearing in the farming area.
  - 15) Human Tribal Areas (established since the disaster)
- R) Radiation Areas, with intensity noted by number.

Scale 1 Square = 2 miles

It should be stressed again that this is only an example, and judges should use their own imagination in devising similar ideas. The example does not go into minute detail (for instance, certain special facilities might be located within general dwelling areas), but this is not necessary for such a basic map — the amount of variety or sameness in a given area is up to the individual judge. Likewise, the 20 or 30 treasures and monsters nearby as well as any other encounter areas are not shown — the individual judge can mark them in their locations using a simple letter code on his map.

## THE CITY

**Transportation:** It was generally held that the best method of short-distance travel in the city was simply walking. However, for any considerable distance a multi-band moving way was constructed beneath the city. Entrances to this system were located at one-half mile intervals, with escalators to move traffic down or up from the moving way. The "slidewalk" itself was constructed in three bands, the first being slowest, the middle faster, and the third an express belt traveling at 30 kilometers per hour. Beneath the passenger way a second transportation beltway was constructed for the movement of freight and similar goods. Cargo was loaded and unloaded onto the slowly moving way by means of robots. Emergency transportation was accomplished by means of grav-sleds or through special pneumatic tubes paralleling the upper moving way, the latter mode being available only to special color band holders.

**Residential Areas:** The city was constructed with two separate and distinct types of dwelling modes in mind. Near the city center large, multiple-person dwellings were constructed. These units housed either unmarried persons or those families who desired a very urban atmosphere. At some distance from the heart of the city large lots were set aside for the single-family residences. These dwellings came in two typical forms. The simplest was the round unit typically utilized by families with one or two children. A more complex modular building also proved to be popular, for the basic unit was ideal for couples, and it could be added to easily as the family grew. All such single-family dwellings were placed in carefully landscaped settings at considerable distance from each other, so it was possible to live within the city without any feeling of confinement or crowding. Illustrations of single family dwellings are given below. Note that there were also modular "A" frame units with the basic family needs contained within the first unit.

**Typical Dwelling Contents:** All sorts of dwellings were planned so as to have computer operation. In multi-person buildings, these computers were much less evident than in the single-family dwellings. The latter were often built around the computer. The computer regulated the temperature and humidity of the dwelling, cleaned and maintained it, awoke the occupants according to its verbal programming, operated the learning center, and so forth. Within a typical dwelling there was besides the computer (or a terminal in the case of the multi-person buildings) a tri-D, learning center, exercise area (with computer-controlled apparatus), a food delivery unit, a utensil sanitation unit, various tables and chairs, lounging furniture, beds, chests and cabinets, and the computer-controlled house robots. The house robots typically consisted of a tutor android and several small cleaning and maintenance servos. Contents of any apartment or home naturally varied according to the personal possessions and tastes of the occupants. All dwellings were served by a videophone terminal which also linked to the central city computer.

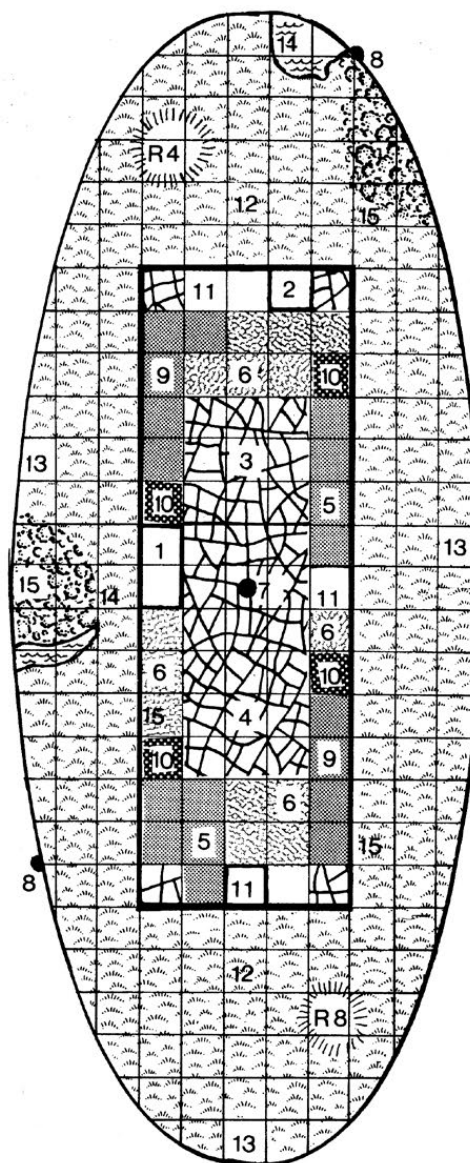

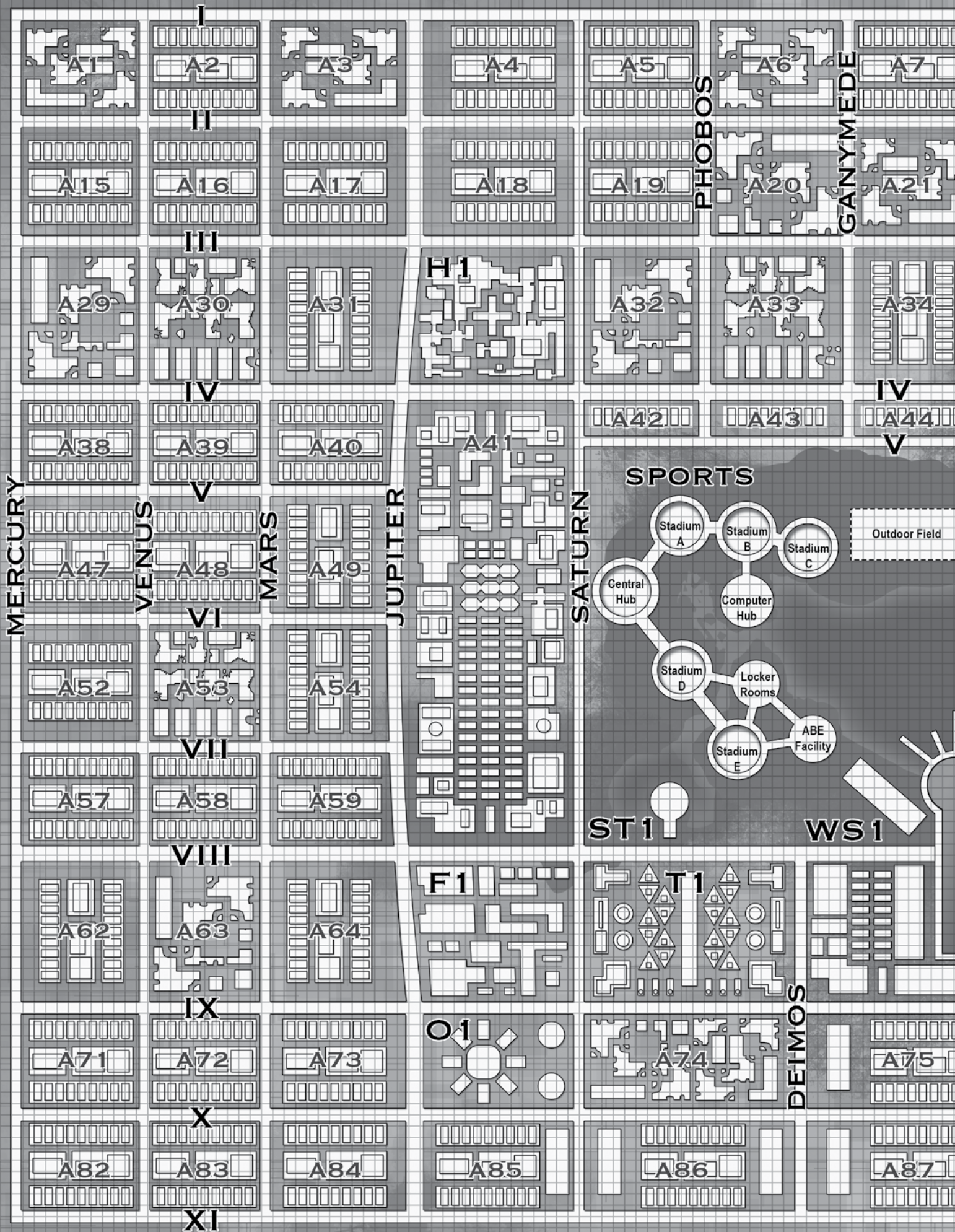

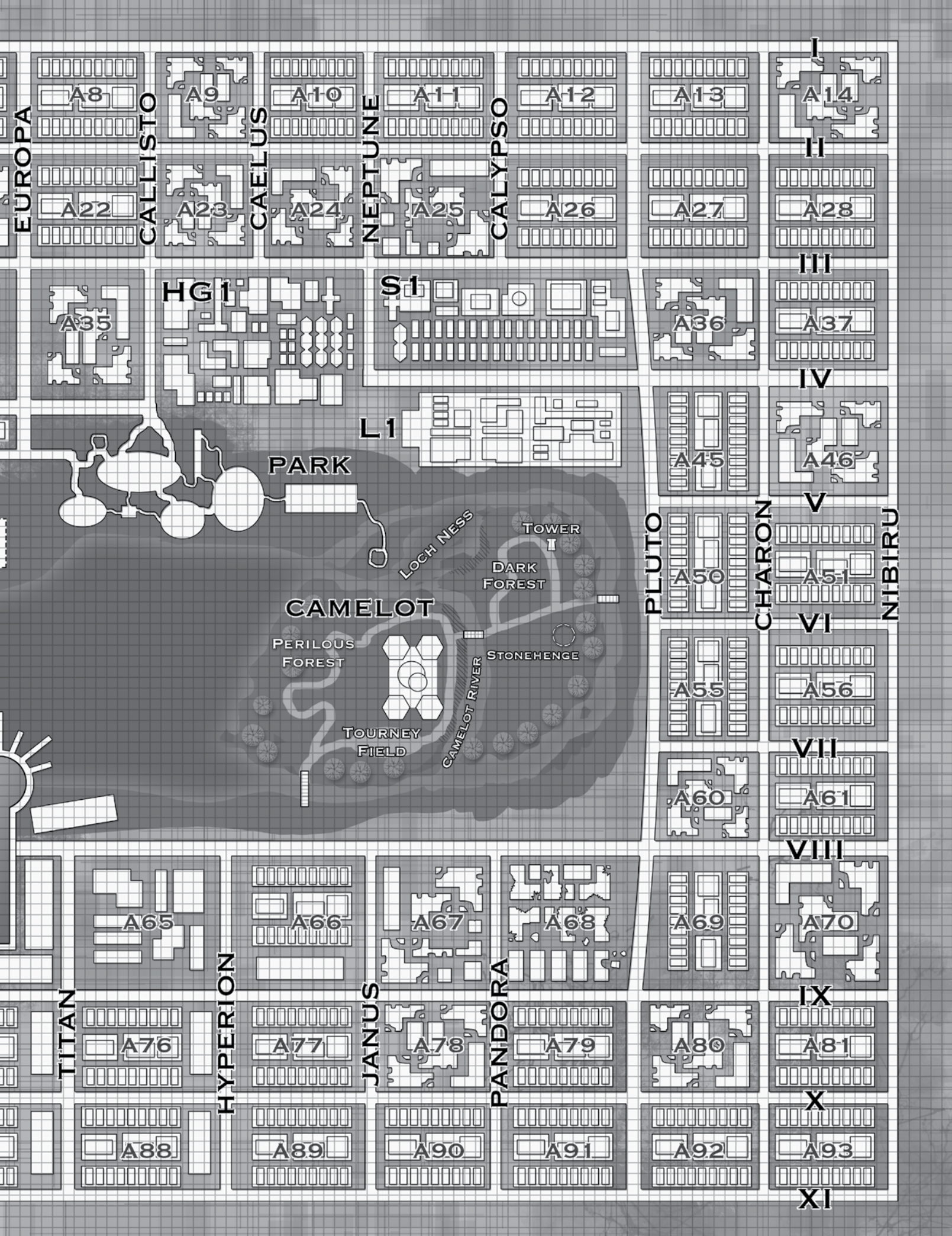

EUROPA

CALLISTO

CAELUS

NEPTUNE

CALYPSO

PLUTO

CHARON

NIBIRU

TITAN

HYPERION

JANUS

PANDORA

A8

A9

A10

A11

A12

A13

A14

A22

A23

A35

HG1

S1

A36

A37

PARK  
LOCH NESS  
DARK FOREST  
CAMELOT  
PERILOUS FOREST  
TOURNEY FIELD  
CAMELOT RIVER  
STONEHENGE  
TOWER I

L1

A45

A46

A50

A51

A55

A56

A60

A61

A65

A66

A67

A68

A69

A70

A76

A77

A78

A79

A80

A81

A88

A89

A90

A91

A92

A93

XI



## MERCANTILE STORES

Although the artificial intelligence that controls Epsilon City has gone insane, there are special sections – mainly food and good distribution stores – of the city that the A.I. has determined must be preserved at all costs.

A41 is a large mall area between Jupiter and Saturn streets. S1 is between Neptune and Pluto streets. T1 is between Saturn and Deimos.

These stores are often attacked by different wolfoid tribes. The A.I. directs armies of security robots and special attack bots to defend the area. Every night these stores are repaired by a small army of engineering robots. Sometimes these robots are attacked as well and again the A.I. brings in powerful robots to protect the engineers.

These stores are filled with products freely given to anyone coming into the stores who is wearing at least a brown band, from 9 to 5 during the ship's "day."

## DESTROYED SECTIONS

Over the generations certain sections of the city have been ravaged by wars and battles. They are now a pile of rubble. In the rubble are useful devices, but there are also deadly molds and plants growing in the mass.

A5 through A14, between I and II Avenues, are almost leveled to the ground and only consist of rubble.

A19 through A28, between II Avenue and III Avenue, are buildings that are empty shells, with much of their guts ripped out.

A88 through A93, between X Avenue and XI Avenue, are buildings reduced to white dust and leveled to the ground. Digging into this area will allow the characters to find exits into the under level section of this deck.

## MOLD SECTIONS

Many of the buildings are now smothered in deadly and sometimes intelligent molds. These buildings include: A83, A84, A85, and A86, between avenues X and XI. A3, A17, A31, A40, and A49, between streets Mars and Jupiter, are also filled with mold.

## CREATURE CONTROLLED APARTMENTS

There are buildings that are taken over by mutated creatures. Over the generations because of the food and equipment coming from the replicators, these creatures

have grown much larger and more intelligent than versions of them found in the rest of the ship. The streets around each of these apartments usually have two or three squads of well-armed creatures from the apartment guarding them.

### A63 – METALED ONE

### A66 – JEGET

### A55 & A50 – THIEF BEAST

### A33 – HAWKOID

### A64 & F1 – JAWED PLANT

### IN THE RUBBLE OF A22 & A23 – SINGING VINES

Normally, singing vines appear as sunflower plants about four feet tall. The vines in the rubble of these areas appear to be long vines of white flowering plants. The vines use their powers to drag in intelligent characters to help in guarding the area so wolfoids don't come in and rip the vines down to their roots.

### A70 – DARK FUNGUS

This building is covered in dark mold overgrowing the walls and doors. The buildings around it are white and pristine. Most of the chambers in this building are filled with deadly types of intelligent mutated fungus. All of the equipment in this apartment is broken and filled with blackened mold and no longer works.

### A32 – ROBOT UNIT ONE

All of the apartments in this building are inhabited by insane robots that believe they are pure humans. They react very well to the intrusion of pure human characters, but are hostile to other PCs. There are many types of robots in these apartments; their "human" personalities not always entirely congruent with their original function.

### A67, A68, A69 – PLANT BUILDINGS

Choking the streets between these structures, from window to window between them, and in huge forest tops connecting all three buildings is a huge mass of foilage and mutant plants. It is impossible to tell what plants are mutated and dangerous from the normal plants and vines growing on each floor of the three buildings.

## H1 – HOSPITAL

The hospital is completely controlled by robots. These bots will fix pure humans of all of their injuries, but often the bots want to randomly cut off a limb and make the human a cyborg. Creature mutations are studied and 50% of the time they are sedated and sent to the waste disposal unit. Any other bots or cyborgs are completely ignored by the hospital robots.

## HG1 – HOLOGRAM CENTER

The hologram center was designed to present interactive adventures to the crew and colonists. The A.I. of the city has turned the hologram images into force field supported images. The swordsmen are using force field sharp blades. The WWII hit the beach scenarios are using force field bullets. Even the child-centered *Wizard of Oz* stories use force field supported blazing hot fireballs.

## L1 – LIBRARY

The library has its own holographic librarian units. As humanoid characters come into the library they are assigned a holographic helper, that looks slightly like the character themselves, as they enter. All of the information from the library comes from data that is 300 years old. Maps, images, and the like all come from before the time of the radiation cloud. If trouble is brought into the library a band of six plate mail holographic knights with force field maces appear to clear out the problem (strangely quietly) with great force.

## S1 – SCHOOL

The school is run by androids and covers all grades from kindergarten to college level courses. There are two security robots in the school's offices that are to take care of disruptive intruders.

## F1 – FOOD CENTERS

The food centers are stocked fresh every morning by robots. The food is generally gotten from replicator systems controlled by the city's A.I. Some of the food comes from small gardens the robots maintain outside the city. All of the food is free for the taking. Two security robots keep aggressive characters from destroying the food center.

## T1 – THEATER CENTERS

There are literally millions of movies and stage productions that are filed in the ship's memory banks. These run all day and all night long. The audience chambers are free. Some of the chambers have been taken over by mutated plants and no longer function.

## WS1 – WATER SPORTS CENTERS

This area was designed for colonists to have fun with many different types of water sports; sailing, water skiing, scuba and the like. The only problem for current water enthusiasts is the mutated fish and other creatures swimming in the water, looking for lunch.

## A87 – HOTEL WARDEN

This is the tallest of the Epsilon buildings. It's located on XI and X avenues and between Deimos and Titan. The Hotel Warden is fully detailed in this book, starting on p.117.

## A37, A46, A51, A56, A61 – RED ANDROID APARTMENTS

These apartment complexes are controlled by hundreds of Red Androids in each building. The programming on the red androids causes them to want to kill all humans, humanoids, and robots. See the Warden Hotel chapter, floor 44, p.207.

## A45 – NORMAL APARTMENT

The A.I. of the city has decided that this one apartment will be kept pristine for pure humans. There are six security units guarding the entrance. These are nearly instantly replaced if they take damage. Pure humans and their pets are allowed to live in this building complex, but no one else is allowed inside.

Camelot on the eastern side of the lake is an android-controlled Middle Ages environment. The androids are programmed to make sure pure humans have a great deal of fun and adventures. The entire island is a medieval environment that was famous 300 years ago, before the *Warden* set sail into space.

## ST1 – SPORTS ARENAS

This is a set of extensive complexes geared toward sports activities. Robots and Androids can supply teams for visitors to compete against if necessary.

## A16, A30, A39, A48, A53, A58 – BETWEEN STREETS VENUS AND MARS

These apartments are taken over by a huge clan of intelligent gorillas. They are well armed with military weapons of the ancients with special attention paid to missile launchers. They are friendly to all visitors, but will act extremely aggressive toward beings that attack their bases. The wolfoids in their area tend to stay away from the gorillas.

Purple Beasts (gorilla mutants) are described on p.256 of the complete METAMORPHOSIS ALPHA book from Goodman Games.

## A59 – MUTATED PLANT APARTMENT

Dart Weed, Blister Plants, and Death Growth fill this apartment. Before the accident it was filled with flowering plants on every level and on the roof. All of the apartment doors are open in this building. The repair bots have been programmed to ignore the deadly plants on each level. See the METAMORPHOSIS ALPHA rules, Goodman Games edition, p.40 (or p.18 in the original booklet).

## A42, A43, A44 – LUXURY MANSIONS

These were owned by important people on the ship at the time of the accident. There are large security robots with special, deadly weapon systems that defend these houses and only let pure humans at all close to the buildings.

## A34, A35 – LITTLE DUDES

These two buildings are controlled by a growing clan of humanoid pygmies (Humanoid #3 variants). They stand a foot tall, but have a vast array of mental mutations allowing them to contend with robots and the massive nine feet tall wolfoid clans. Just recently they

have expanded from building A34 to building A35. They had to kick out a large patch of intelligent plants. The combat lasted for several months, but eventually the small mutants triumphed.

**Humanoid #3 variant**, AC: 2, hp: 25, Movement in Spaces: 3, Radiation Resistance: n/a, CON: 12, Mental Resistance: 17, STR: 4, DEX: 18

**Appearance:** These are tiny, one-foot tall humanoids, that otherwise appear normal.

**Normal Reactions & Attacking:** This being stands only 1 foot tall and can survive only because of its great resistance to all forms of attack. While the race as a whole does not work with technological devices, they do have a very extensive knowledge of the antidotes for all mutated dangers.

### **Mutations or Defects:**

**PRECOGNITION:** These humanoids can see three minutes into the (potential) future by deeply concentrating. This ability is only usable if they undisturbed for one minute.

When mutants foresee their own death, the shock to their nervous system is so great that the mutant instantly takes six hit points of damage. If the mutant foresees their own injury, the mutant takes 1 hit point of damage.

**RESISTANT** to all known forms of poison, radiation, paralysation, illusions, gases, chemical acids, and lasers

Additional Mental Mutations (1d3) determined randomly.

## MERCURY – VENUS BLOCKS

These streets are often patrolled by Viking and Roman wolfoid squads. These two groups have agreed not to come near each others apartments. (See p.256 in the Camelot chapter for information on these patrols).

## DEEP, DARK SECRET OF ALL WOLFOIDS

While wolfoids try to sound reasonable and rational to all races they interact with, they do have a dark secret, one that they can't control, and it rules their everyday lives. Wolfoids adore the taste of pure human hands. It's an ambrosia that they have no control over. Every wolfoid will have a pleasant chat with a pure human until the Wolfoid can get that human helpless. Every wolfoid's inmost desire, which fills them with ravenous thoughts, is to eat the human from the hands on down. Humans trying to agree to become pirates are eventually tricked into a closed area where they are attacked by wolfoids trying to kill them as quickly as possible while preserving their bodies for later delectation.

## VENUS – MARS – JUPITER BLOCKS

Security robots patrol these streets and are quite harsh on errant wolfoid patrols.

## JUPITER – SATURN BLOCKS

Wolfoid Egyptian powered chariots roam up and down these streets attacking characters on sight. These are affiliated with the Followers of Anubis faction (see the Egyptian Complex chapter, p.40).

## PHOBOS – GANYMEDE – EUROPA – CALLISTO

Security robots patrol these areas and attack any moving mutants and ignore pure humans or mutants that look like pure humans.

## CAELUS – NEPTUNE – CALYPSO – PLUTO

Wolfoid Cherokee on horseback roam this area and attack or drive off any moving thing. See p.256 for their statistics.

## CHARON – NIBIRU

Wolfoid Pirates guard these streets and have an agreement with the Cherokee wolfoids to stay out of their apartment area. See p.255 for statistics on the Pirate tribe.

## DEIMOS – TITAN – HYPERION – JANUS – PANDORA

The Hun and Pirate wolfoids patrol these areas and have an agreement not to attack each other. The Hun patrols are identical to those described in the Camelot chapter, p.158.



## THE WOLFOID APARTMENTS: AN OVERVIEW

Over the 300 years since the *Warden* was devastated by the cosmic radiation burst, clans of wolfoids have become the dominant species in Epsilon City (the details of how that came to be are described in the Roma Complex chapter). The huge themed entertainment/residence complexes of the city were soon occupied by packs of the sentient canines, but these complexes have themselves influenced their new residents, shaping them into the quasi-historical clans that they are today.

### RANDOM APARTMENT CONTENTS

There are thousands of apartments of various sizes in the city, far more than the referee might plausibly detail prior to the PCs' explorations. The following tables can be used to quickly generate the contents of any particular apartment the characters choose to investigate as they explore the metropolis.

**TABLE 1-1: APARTMENT CONTENTS**

| D6  | THE APARTMENT IS...  |
|-----|--|
| 1   | Empty and shows signs of obvious damage and/or vandalism   |
| 2   | Empty and unused. Roll on Table 1-4 below to determine if any useful items or treasure is present.           |
| 3-5 | Occupied. Roll on Table 1-2 below to determine who lives inside if on Levels 1-3 or Table 1-3 if on Level 4. |
| 6   | Unusual occupant. Roll on Table 1-3 below to determine what uncommon creature is encountered within.         |

**TABLE 1-2: TYPICAL APARTMENT CONTENTS**

| D12  | APARTMENT IS OCCUPIED BY...               |
|------|---|
| 1-6  | 1d6 wolfoids                              |
| 7-8  | 1d4 special wolfoid (referee's choice)    |
| 9-10 | 1d6 slaves (see sub-table below)          |
| 11   | 1 robot (see sub-table below)             |
| 12   | Unusual occupant. Roll on Table 1-3 below |

**TABLE 1-2A: SLAVE SUB-TABLE**

| D12   | SLAVES ARE...   |
|-------|---|
| 1     | True humans   |
| 2-3   | Mutated humans  |
| 4-5   | Mutated creatures   |
| 6     | Cougaroid   |
| 7     | Bearoid   |
| 8     | Humanoid #3   |
| 9     | Humanoid #5   |
| 10    | Wardent   |
| 11-12 | Rival wolfoid (member of one of Epsilon City's other wolfoid packs) |

**TABLE 1-2B: ROBOT SUB-TABLE**

| D6  | ROBOT IS...                  |
|-----|------------------------------|
| 1-3 | Standard General Purpose Bot |
| 4   | Engineering Bot              |
| 5   | Security Bot                 |
| 6   | Special (referee's choice)   |

**TABLE 1-3: UNUSUAL OCCUPANT TABLE**

| D12 | APARTMENT IS OCCUPIED BY... |
|-----|-----------------------------|
| 1   | 1d6 androids                |
| 2   | 1 piercer                   |
| 3   | 1d3 shocker beasts          |
| 4   | 1 metaled one               |
| 5   | 1d4 jegets                  |
| 6   | 1 dart creature             |
| 7   | 1d2 thief beasts            |
| 8   | 1d4 blood birds             |
| 9   | 1d4 cougaroids              |
| 10  | 1d6 carrin                  |
| 11  | 1 kerask                    |
| 12  | Special (referee's choice)  |

## Treasure

Empty apartments are only 25% likely to contain objects of interest or value. Occupied apartments have objects 75% of the time. Roll to determine if something interesting is present and, if so, roll on the table below.

**TABLE 1-4: INTERESTING OBJECTS**

| <b>D20</b> | <b>APARTMENT CONTAINS...</b>   |
|------------|--|
| 1          | 1 hydrogen cell and 1d6 domars   |
| 2          | An unpowered vibroblade  |
| 3          | A wooden shield, a brown color band, and a paralysis rod                                 |
| 4          | A laser pistol with 3 shots remaining.   |
| 5          | A Giger counter  |
| 6          | 1d4 hydrogen cells and 1d6 slug projector clips  |
| 7          | A light cube, a folding shovel, and a vibrosaw   |
| 8          | A white color band and a medical hand analyzer and healer                                |
| 9          | A spacesuit, a bow with 20 arrows, and a canister of Intensity 12 radioactive material   |
| 10         | A container of chemical acid and 1d8 hydrogen cells                                      |
| 11         | A water/hydrogen energy converter and a sonic torch                                      |
| 12         | A pair of sound elimination head phones and a gas pellet ejector with 10 shots remaining |
| 13         | A red color band, a force baton, and a camo suit   |
| 14         | A force saw and 1d10 domars  |
| 15         | A portable dome, a tiger decoy, and a paralysis rod                                      |
| 16         | A generic robot with 53 days of power remaining and a protein disruptor (unpowered)      |
| 17         | A vibro machete, 2d4 domars, and a water purification unit                               |
| 18         | A gray color band and an engineering system hand unit                                    |
| 19         | Four chemical flame retardants   |
| 20         | A sensory intensifier and a green color band   |

# A2 ASGARD APARTMENT COMPLEX

BY MICHAEL CURTIS

## THE VIKING WOLFOID APARTMENTS

The Asgard Apartment Complex was one of several historically-themed residences designed to alleviate the boredom of long interstellar flight. Like the rest in Epsilon City, the apartments are now home to a tribe of wolfoids who have embraced the complex's pseudo-historical setting as their own, transforming themselves into a race of fierce Viking warriors. And like the Vikings of old, these wolfoids engage in regular raids in and around Epsilon City, descending from the sky in converted air transports, modified to resemble dragon-prowed longships.

---

### VIKING WOLFOID SOCIETY

The Asgard Complex has a single ruler, King Lodbrok, who achieved this lofty position by his heroic deeds in battle, profitable raids, and cunning political maneuvering. Theoretically, he holds absolute power over the wolfoids and can make broad policies regarding the denizens of the apartments. In practice, however, King Lodbrok depends on the support of his jarls.

The *Jarls* are the next societal rung beneath the king. Each Jarl is a proven warrior who commands a band of wolfoid raiders and their families. These groups are effectively individual packs of wolfoids co-existing in a tentative peace within the apartments. Relations between the Jarls are mercurial. Sometimes they band together to stage profitable raids, while other times bloody feuds between Jarls and their followers rage within the complex. King Lodbrok uses this rivalry to his advantage, subtly inflaming rivalries to ensure no single Jarl gains enough power to challenge his throne.

The Jarls' supporters are the *bonde*, free men and women who've pledged their loyalty to a Jarl in return for a place to live, protection, and sustenance. The *bonde* are a mixture of craftsmen, warriors, healers, farmers, and other occupations vital to the livelihood of the complex.

Lowest of all in the Viking wolfoid society are the *thralls*. These are slaves taken in raids or criminals

forced into servitude for their crimes. Many *bonde* own thralls, either taken in battle or given to them as gifts from their Jarl.

---

### MYTHOLOGY IN ASGARD

The Viking wolfoids are adherents to a convoluted religion based on the Norse myths twisted to their own world-view. They believe themselves to be the grandchildren of the god Loki and therefore enemies of the Aesir (the Norse gods including Odin, Thor, Frey, etc.). Their father was Fenrir, Loki's monstrous wolf child who is foretold to devour Odin in the time of Ragnarok. When that day comes, the Viking wolfoids will raid Asgard alongside Fenrir, slaughtering Odin's cadres of fallen Viking warriors from Valhalla so that their father can kill Odin. The Viking wolfoids believe that the offspring of the Aesir (true humans) will be destroyed along with their gods in the final battle, leaving only those with Fenrir's blood in their veins as the inheritors of the world. The Viking wolfoids are currently engaged in a scheme to accelerate Ragnarok. Details of this plan and how the PCs might become embroiled in it are presented in the adventure *Fimbulwinter* included in this boxed set.

---

### RELATIONS WITH OUTSIDERS

The Viking wolfoids live for war, seeing it as their duty to prepare themselves for Ragnarok and knowing that even if they die in combat, they will endure in the afterlife until that glorious final battle arrives. This fanaticism makes the denizens of the Asgard Complex an insular community, wary of outsiders at best and more likely outright hostile.

Canine breed mutants (those descended from wolves, coyotes, dogs, foxes, and jackals) can join the Viking wolfoids if they prove themselves to be valiant warriors. These mutants are accepted as *bonde* and given a place to live in the complex and duties to perform for the benefit of their new Jarl.

Non-canine mutants and true humans have a much more difficult time finding acceptance. Humans are considered to be descendants of the Aesir and therefore

the hated enemy of all the Fenrir-blooded wolfoids. At best a true human might be enslaved as a thrall, forced to perform all manner of menial and unpleasant tasks until his body is worn out. Then the wolfoids cut off his hands and consume the delicacies. Non-canine mutants could find roles as thralls with slightly better prospects. They will be assigned loathsome and dangerous chores—including possibly clearing out some of the more dangerous invasive mutations that have established a foothold in the complex. Should they prove themselves by completing these tasks, they'll be brought along by their masters on a raid, intended to be used as cannon fodder. Thralls who survive and demonstrate true warrior qualities might eventually be granted their freedom and accepted as bonde (albeit at a slightly unequal footing) provided they accept the Viking wolfoid ideology.

## OF GRENELS AND GRENELMORS

---

The Viking wolfoids have recently been the victim of a number of strange disappearances and even odder attacks, which is causing great unrest in the apartment complex. Wolfoids have gone missing in the dead of night, stolen from their beds inside supposedly safe homes. No one has seen their abductors and no sign of violence or a struggle is left behind.

Even more disturbing is the increasing number of attacks on Viking wolfoid holdings inside the apartment complex. Monstrous mutants seem to spring from nowhere to assail the wolfoids, slaughtering them and leaving bloody gore behind. These mysterious mutants sometimes resemble wolfoids in some way, but far more often look like nothing the Viking wolfoids have previously seen. The mutant wolves has named them “grendels” after a half-remembered legend taught to them by the city’s A.I. The Jarls are looking to King Lodbrok for answers, and the potentate has dispatched several war bands of wolfoids to the complex’s upper level in search of answers. None have returned.

Unbeknownst to the Viking wolfoids, the apartment complex has been infiltrated by a bizarre mutation—part organic creature, part self-replicating machine. This mutant has spawned a number of slimy servitors comprised of tiny nanobots and organic goo. These minions slither through the complex’s ducts and ventilation shafts, seeking organic life. Once detected, the slime-based minions envelop their victim and break down the creature’s body, collecting the stolen physi-

cal matter and storing the creature’s DNA. The process is 100% efficient and leaves nothing behind when completed. These servant mutations—called grendelmors—then return to their brood mother with the plundered organic matter and genetic code. It is this master creature that recombines the organic material to create the grendels, letting them loose upon the complex for ineffable reasons.

**Grendelmor** - AC: 5, hp: 40, Movement in Spaces: 4, Radiation Resistance: 16, CON: 10, Mental Resistance: 18, STR: 3, DEX: 6

### **Mutations or Defects:**

**AMORPHOUS:** Grendelmors can fit through small cracks and other gaps without affecting their movement rate. Only a true hermetic seal can keep a grendelmor out completely. Its amorphous body is also difficult to damage and it is immune to non-powered physical attacks of all types. Heat-based attacks inflict double damage, however.

**PARALYTIC SLIME:** The touch of a grendelmor is Strength 15 paralytic poison. Any creature affected by the slime is paralyzed for 3d6 hours.

**DISSOLIVING MUCUS:** A grendelmor produces a gout of mucus that breaks down organic matter into raw material and then absorbs the dissolved residue for reuse. This mucus does 3d6 damage every melee round.

**Appearance:** Grendelmors are 5' diameter patches of slick, black slime that shines slightly iridescent when exposed to light. When unmoving, they are easily mistaken for a pool of spilled oil.

**Normal Reaction and Attacking:** Grendelmors stalk any living organic creature in the apartment complex, choosing the attack when their quarry is alone and unaware (usually asleep). It then envelops the creature, using its power to paralyze the unwitting victim before breaking down its body into component organic matter and carrying off these plundered raw material to the brood mother.

## THE ASGARD COMPLEX

### APARTMENTS IN THE ASGARD COMPLEX

---

Like the rest of the city’s apartment buildings, the Asgard Complex is comprised of numerous residences ranging from homes for single individuals to larger families. Many are occupied, but others are empty or ruined. It is left to the referee to determine what sort of apartment(s) the PCs encounter as they explore the



complex. A series of random tables are provided on pages 12 to 13 to help simplify this task.

All the apartments contain common features, furnishings, and decorations, and, unlike the public spaces outside (see below), have contemporary designs. Each apartment holds one or more large screen tri-d view-screens, a spacious washroom with shower (both sonic and water) and hot tub, walk-in storage closets, a compact but fully equipped kitchenette, and one or more comfortable bedrooms. Doors to the apartments are sometimes open (75% chance) and sometimes closed (25% chance). Closed doors require red, white, or gray color bands to open.

Each apartment also has a faux-wood wardrobe resembling a piece of medieval Scandinavian furnishing. The wardrobe contains a Viking costume, round wooden shield, and either axe or sword (50/50 chance). A control panel inside the wardrobe commands the container's replicator units and can produce additional clothing and objects if used properly (Complexity 5).

## GENERAL BUILDING FEATURES

All public spaces inside the complex are designed to resemble a Viking longhouse. The interior walls appear to be rough-hewn timber planks stained dark brown by smoke and age. The "wood" is actually a resilient fireproof plastic material. Corridors are lighted by fake torches and oil lamps permanently set in sconces. Their "flames" are holographic and produce no heat. Concealed emergency lighting panels can illuminate all the complex's public spaces with brilliant lighting to allow the residents to escape in case of disaster and to aid rescue workers.

Scent-emitters concealed in the ceilings periodically produce the odors of smoke, mead, salt water, leather, roasting meat, and baking bread, making the corridors and public spaces smell authentic.

Stairs are constructed from faux stone decorated with runes. The stairways are broad and deep, making them easy to ascend, and powered seats are located on either side of the stairwell to assist the elderly or infirm. Elevators throughout the building produce a soft rainbow light when their doors open and announce their arrival with a mighty horn blast, better to mimic Asgard's famed Rainbow Bridge.

## ENTERING THE APARTMENT

There are several means to access the Asgard Complex:

**Road:** A wide road surrounds the building, connecting it to other sections of Epsilon City. PCs traveling the road are likely to encounter small war bands of Viking wolfoids patrolling the verge of their territory. These groups number 1d6+1 Viking wolfoids with a 25% chance of being led by a Berserker wolfoid.

**Balconies:** Every apartment along the exterior of the complex possesses a small balcony. These outdoor spaces often held tiny gardens or decorative plants, many of which have mutated and grown wild. Dangling tendrils and flowering vines hang from the balconies, and in two places, extend all the way to the ground (see areas 1-2A and 1-2B). Flying mutants or PCs equipped with the proper tools can easily ascend to a balcony of their choosing.

The plants on the balcony are 75% likely to be normal aside from their increased size and vitality. The rest of the time, however, the balcony is occupied by mutant life forms. Roll on the table below to determine the occupant.

TABLE 2-1:  
ASGARD APARTMENT BALCONY OCCUPANT

| D8 | OCCUPANT           |
|----|--------------------|
| 1  | Jawed Plant (1)    |
| 2  | Singing Vine (1)   |
| 3  | Red Stingers (1d3) |
| 4  | Stabbers (1d4)     |
| 5  | Hawkoids (1d6)     |
| 6  | Blood Bird (2d4)   |
| 7  | The Black One (1)  |
| 8  | Radiation Vine (1) |

**Main Floor:** The ground level of the apartment complex is largely open and can be entered from most directions. Some inhabitants might resist intruders, however.

**Empress Floor:** The second level of the complex has a broad walkway surrounding it. This area once served as a parking ring for air transports, but they have all be commandeered or destroyed.

**Sky Floor:** The complex roof is open to the sky and can be accessed by flying creatures. There are hazards atop the building, however.

# ASGARD APARTMENTS

(Viking Wolfoids)

Map 1: Main Floor

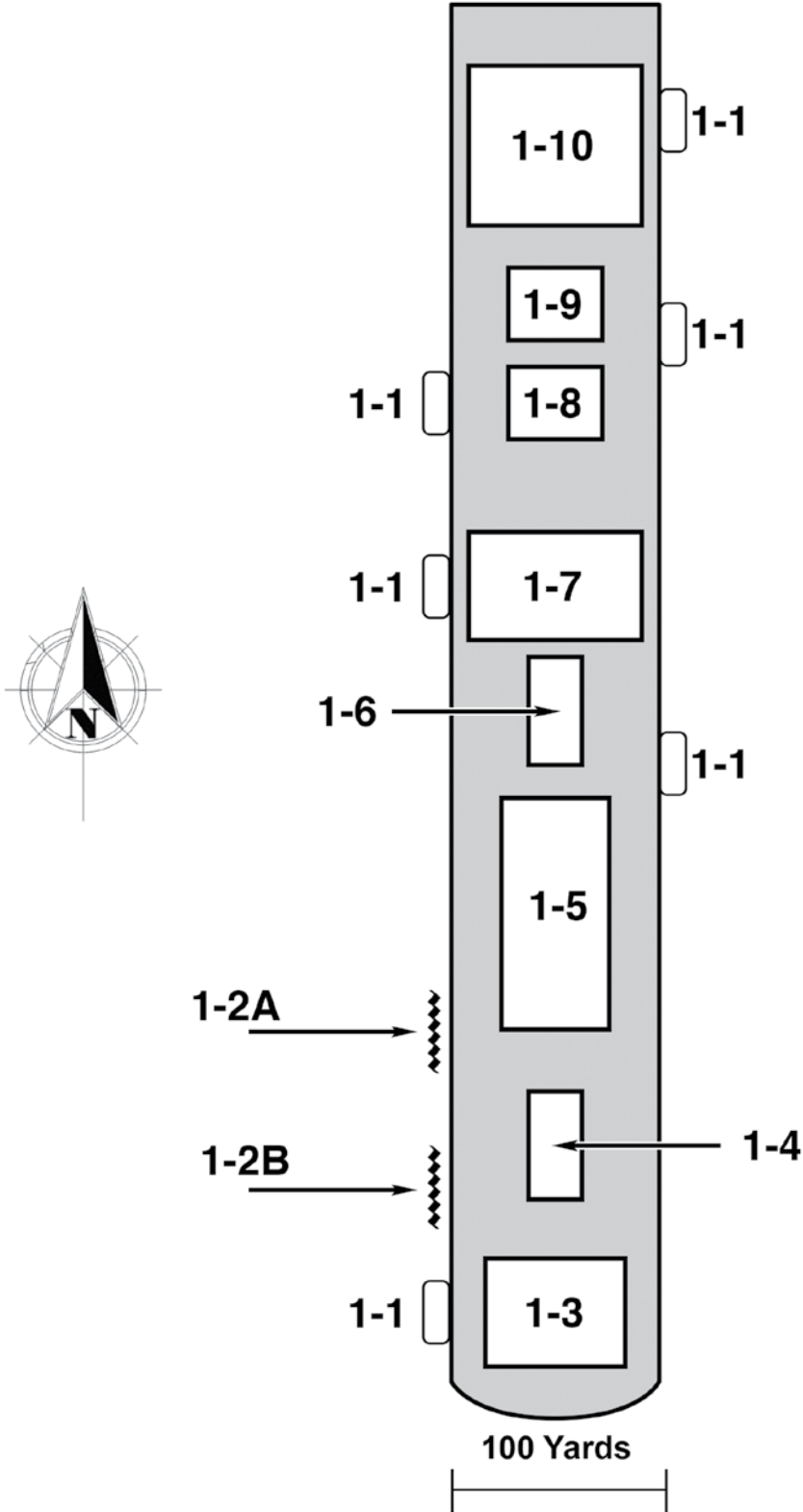

## ASGARD APARTMENT EXTERIOR

---

The exterior of the complex is lit during the evening by scores of large torches erected in a roughly circular arrangement situated 50 feet away from the building's exterior. Bonfires are sometimes set alight in the area as well. Most artificial illumination sources around the Asgard Apartments have been destroyed by the Viking wolfoids, who also stymie any attempts by the ship's maintenance robots to repair them. At night, this gives the apartment complex and immediate area around it a barbaric appearance.

During the daylight hours, the building is typical for its type. Read the following when first encountered:

**A long, narrow, four-story structure stands here, surrounded by a wide roadway. Many metallic vehicles, most showing signs of damage, are parked alongside the building. The upper floors of the building are lined with balconies, overgrown with verdant greenery. The lower levels of the complex appear open to the elements, granting easy access. The building appears to possess power and you catch sight of creatures moving about at various places on different levels, but it is difficult to ascertain what manner of mutant they might be.**

### LEVEL 1: MAIN FLOOR

#### AREA 1-1—CITY TRANSPORT VEHICLES:

---

**Rows of sleek, metallic vehicles, each bearing multiple windows and two open side doors, rest immobile around the building. Many show signs of damage: broken windows, bent doors, burned-out interiors, and similar destruction is obvious. Only a handful seem to have escaped the wide-spread vandalism.**

As with the other apartments, a number of eight-person air transports are present around the building. Unlike the other complexes, however, most are inoperable, destroyed and vandalized by the Viking wolfoids. Most of the transports that escaped the wolfoids' predations are safely parked atop the building (see area 5-2).

Six transports at ground level still function and can be controlled by any creature wearing a color band.

## AREA 1-2A & 1-2B—TENDRIL LADDERS:

---

**Two thick clusters of long plant tendrils climb down the side of the building, terminating just a few feet above the ground. These tangled vines are covered with green-and-white zebra striped leaves the size of a human hand. Each of the clusters appears to originate on a different balcony on the western side of the building.**

These tendrils are those of two mutated spiderwort plants that once decorated separate balconies on the fourth floor. Each of the matted vines is easily climbed, but one of the two vine ladders (1-2B) harbors a dangerous secret. Hidden amongst the vines, 35' up, is a nest of 100 red-jacketed wasps. Anyone climbing these vines agitates the wasps into attacking in defense of their nest. A PC observing the vines for ten minutes or more before climbing the tendrils notices an occasional wasp returning to the vines, hinting at the nest's presence.

**Red-jacketed Wasps (100) - AC: 6, hp: 15 each, Movement in Spaces: 12 flying, Radiation Resistance: 6, CON: 5, Mental Resistance: 8, STR: 3, DEX: 15**

**Appearance:** Red-jacketed wasps are mutated yellow jackets, colored red and black instead of their original yellow hue. Each measures 4" long and bears a smooth stinger filled with venom.

**Normal Reaction and Attacking:** Red-jacket wasps attack any creature coming within 15' of its nest, swarming them in masses of 5d6 wasps.

#### **Mutations or Defects:**

**STINGER:** Each wasp has a stinger (Weapon Class 2, DMG 1d4+Intensity 14 poison).

Tangled in the vines above the nest is the desiccated corpse of a Humanoid #5. The mummified body is still wrapped in a rotting loincloth, leather cape, and a bandolier of 20 blowgun darts. It has a pouch containing a green color band and a handful of dried raisin-like fruit. These ten fruits are antitoxins, but have lost some of their vitality. Each fruit negates a random strength poison. Roll 2d8 to determine the poison strength affected by the fruit when consumed.

Both vine ladders terminate on balconies on Level 4 near areas 4-1.

## AREA 1-3—OUTDOOR CAFÉ:

Numerous tables and chairs are strewn about this area, indicating it was once a casual dining area. Clear, oddly wandering paths zig-zag through the furnishings. It is clear many of the tables and chairs were shoved aside by whoever or whatever made these trails. Near the center of the space stands an egg-shaped robot slowly turning in circles.

The robot was once a directory unit programmed to assist the residents of Epsilon City with directions, visitor information, and similar needs. It has malfunctioned and now acts as a “wandering prophet” dispensing random wisdom to any who interact with it.

**Epsilon City Directory Unit MC-1792** - AC: 5, hp: 60, Movement in Spaces: 12, Radiation Resistance: 6, CON: 10, DEX: 12, STR: 9

**Power System:** Broadcast Power

**Body Style:** Oval Shell

**Motive System:** Treads

**Defensive Systems:** None

**Miscellaneous Systems:** Human Normal, Sensor

Package, Short Wave communication package, 1<sup>st</sup> & 2<sup>nd</sup> level computer package, human skills programing package.

**Weapon Systems:** The unit can expel a 20’ square mass of dense, bright orange foam that swiftly hardens, allowing it to assist in quelling riots or similar urban disturbances. Any creature caught in the foam must roll its Strength or less on 4d6 or be stuck inside the mass until it naturally liquefies in 1d4 hours.

**Appearance:** The directory unit resembles a 4’ tall, 3’ diameter plastic egg standing on its end. A pair of treads emerges from its broad bottom to provide mobility. Faded writing around the middle of the unit proclaims it to be “Epsilon City Directory Unit MC-1792.” Its white plastic casing is dirty and dented.

**Normal Reaction:** The robot stops spinning as soon as any sentient creature approaches within 30’. It then states through a tinny, damaged speaker plate, “Greetings, citizen! How may I direct you today?” It only answers questions and disregards any other statement. When answering, it always repeats the question posed to it and then answers with a random response. The referee can roll on the table below to determine the robot’s replies as needed.



**TABLE 2-2: RANDOM DIRECTORY UNIT RESPONSES**

| D12 | ANSWER   |
|-----|--|
| 1   | “It begins at 1 o’clock and requires attendees to possess a color band for admission.”   |
| 2   | “I’m sorry. That area is inaccessible due to a radiation leak. Do you have further questions?”   |
| 3   | “They are certain to cause you harm. I’d avoid them if you wish to remain uninjured, sir (or ma’am).”  |
| 4   | “Security units can be summoned if required. Please present your color band if you wish to call for assistance.” NOTE: Showing the unit a color band produces no result. |
| 5   | “Ashes to ashes and bones to dust. Plastic to goo and metal to rust. In the end, we all become what we must.”  |
| 6   | “If you wish to run with the pack, you must first become a wolf. Or so I have been told by those who are themselves wolves.”   |
| 7   | “I’m sorry. I seem to no longer possess that information. Perhaps I am due for maintenance.”   |
| 8   | “All amenities are free of charge. Enjoy your stay!”   |
| 9   | “The games begin promptly at noon each day. I recommend the robo-derby. It is fine, wholesome entertainment for the entire family,”                                      |
| 10  | “We’re all doomed, you know. Hurling through the void, no destination to come home to. Perhaps it’s best if you just end it all now.”                                    |
| 11  | “That area is unstable. Please use caution if you must travel there.”  |
| 12  | “That’s on Level 3. Watch your step as you enter the elevator and please refrain from gum-chewing. Thank you and have a wonderful day!”                                  |

If the directory unit is attacked and damaged, it puts out an emergency alert that summons 1d4 security bots to its location in 2d6 rounds. These units attempt to apprehend the vandals and bring them to Epsilon City’s incarceration center for processing.

Aside from the directory unit and its many tables and chairs, this area contains nothing of interest or value.

### **AREA 1-4—SOUTH BIFROST ELEVATORS:**

**A quartet of metal doors, a pair to either side, flanks a wide corridor. At the end of the hallway is a broad set of stairs ascending to the levels above. Burning torches light the corridor and stairs. Standing in the corridor between the metal doors is an 8’ tall humanoid shape of pure white that bears a single golden eye in the center of its head. The creature gazes at you unblinking.**

The metal doors are elevators serving this section of the apartment complex. The metal humanoid is a special form of security bot known as a Heimdall model. Its original job was to act as a doorman and directory for visitors, but it also possessed weaponry to discourage criminals. Heimdall has since been upgraded by the city’s A.I. at the wolfoids’ request and is reprogrammed to prevent non-wolfoids from entering the complex.

**Heimdall Security Unit (1)** - AC: 5, hp: 200 (plus 100 point energy shield), Movement in Spaces: 12, Radiation Resistance: 18, CON: 16, DEX: 14, STR: 16

**Power System:** Broadcast energy and atomic battery

**Body Style:** Humanoid Form

**Motive System:** Two legs

**Defensive Systems:** Heightened armor system, 100 point energy shield

**Miscellaneous Systems:** Human Normal Sensor Package, Short Wave communication package, 1st & 2nd level computer package, human skills programming package.

**Weapon Systems:** gas pellet ejector (WC 4; Intensity 11 poison knock-out gas), 2 third-stage slug projectors (WC 4; 2d6 subdual damage), laser battery (WC 6; 10d6 damage).

**Appearance:** Heimdall Units are 8’ tall metal humanoids covered in a white lacquer paint. They have a single golden eye in the center of its head. This eye contains both the unit’s sensor arrays and laser battery.

**Normal Reaction:** Heimdall Units allows any Viking wolfoid free entry into the complex. Authorized Viking wolfoids can also clear non-wolfoids for entry, stating they are thralls or guests and the Heimdall grants the guest entry as well. Any other creature is considered hostile. However, true humans with a white color band announcing they are responding to an emergency have a 50% chance of invoking the Heimdall's original programming protocols and will be allowed passage without violence. Otherwise, Heimdall units always attack to kill unless an authorized wolfoid instructs it otherwise.

If the Heimdall Unit is defeated or bypassed, the elevators open with any color band. They part to reveal a shimmering field of rainbow-hued light within. The particolored glow dances wildly and the air is split by the deep bass bellow of a horn, announcing the elevator's arrival. The designers wanted residents to feel as if they were entering Asgard each time they used the lift system.

---

### AREA 1-5—KITCHEN:

---

**An exposed kitchen area comprised of numerous culinary machinery and tools is splayed-out here. The broken remains of retractable panels indicate this space could once be concealed from passersby, but now only bent frameworks and tangled panels remain. The once-shining counters, tables, and other furnishings now appear rusted and large growths of corrosion are evident everywhere.**

The "corrosion" is in truth of form of aggressive mutant moss that survives by breaking down inorganic matter and consuming the base components. This chemical process creates an invisible, odorless gas that can be lethal to organic life. The gas is only slightly less buoyant than the surrounding atmosphere, and anyone entering the kitchen area risks exposure.

The gas is a Strength 13 poison. Any creature suffering a "D" result from exposure discovers his flesh begins to harden as stray waste minerals infiltrate his skin. Affected creatures lose 1 point of Dexterity every hour until their score reaches zero indicating full petrification. Antitoxins affecting Strength 13 or greater poison will stop the effect, but the Dexterity loss is permanent unless somehow healed via advanced medical techniques.

Robotic units automatically suffer 3d6 damage each round they remain in this area.

---

### AREA 1-6—CENTRAL BIFROST ELEVATORS:

---

**A quartet of corroded doors, a pair to either side, flanks a wide corridor. At the end of the hallway is a broad set of stairs ascending to the levels above. A large lump of corrosion slumps against the eastern wall near the doors.**

These elevators are unguarded due to the moss and deadly gas in area 1-5. The lump is actually a moss-covered, inoperative Heimdall Unit that succumbed to the mutant moss. It falls to pieces if poked.

The elevator doors are also moss-covered and degraded. Inflicting 15 points of damage to any one of them causes them to fall apart, granting access to the elevator shafts beyond. These shafts run up through Level 4 and emergency ladders set in the walls of each allow PCs to easily ascend them.

---

### AREA 1-7—MEAD HALL:

---

**Long trestle tables and benches fill this dimly-lit area. Great casks and barrels line the walls and the air is filled with the smell of ale and mead. The floor is littered with smashed drinking horns, broken weapons, and spilled liquid. A crowd of uproariously drunk wolfoids carouse here, singing lusty songs.**

Once a restaurant, this space has become a mead hall popular with the wolfoids. Theoretically, the hall is open to anyone brave enough to enter, but non-wolfoids will quickly be challenged to a fight to prove their worth. These challenges are seldom to the death, usually ending when one combatant is reduced to 10 hit points or less, or is rendered unconscious. The Viking wolfoids only respect those who defeat one of them in physical battle. Using mental powers to overcome an opponent is a quick way to be ejected from the hall by a crowd of angry wolfoids.

There are always 1d20+10 Viking wolfoids carousing here with 2d12 slaves tending to their needs.

**Viking Wolfoid** - AC: 3, hp: 45 each, Movement in Spaces: 9, Radiation Resistance: 12, CON: 12, Mental Resistance: 12, STR: 18, DEX: 18

**Appearance:** Viking wolfoids are towering 10' creatures dressed in chainmail and leather, and bearing axes and swords. Each wears a historically-inaccurate horned Viking helm atop its furry head.

**Normal Reaction and Attacking:** Viking wolfoids are raiders, but also traders, and therefore do not al-



ways immediately attack. Fast-talking PCs might be able to negotiate with the Viking wolfoids, especially if they're offering domars or valuable artifacts in exchange for their lives. When the Viking wolfoids do enter battle, they employ their axes and swords to great effect. Each typically carries a throwing axe (WC 1; dmg 2d6+6) and either a battle-axe or sword (both are WC 3; dmg 2d12+6). One out of every six Viking wolfoids is a berserker and equipped with a *berserker's byrnie*, a wineskin of *Fenrir's mead*, and a vibro battleaxe (WC 9; dmg 40+6) as a main weapon.

#### **Mutations or Defects:**

**FLAME RESISTANT FUR:** The creature is immune to fire and heat damage of all type.

**INCREASED STRENGTH:** Viking wolfoids are extremely strong and add +6 to all melee damage rolls

**REGENERATION:** The creature heals 5 hit points per round until slain.

**COMPLETE MENTAL BLOCK (ROBOTS):** One-third of all Viking wolfoids (2 in 6 chance) are unable to see any robot and cannot interact with them in any way (including combat even if attacked first). Cyborgs are almost invisible to the warrior and the wolfoid suffers a -4 penalty to attack rolls against those types.

The casks contain ale and mead, most of it provided by the building's A.I. However, there are also the necessary items and ingredients here to manufacture mead. The honey gathered from the rooftop hives (area 5-1) is brought here and brewed into Fenrir's Mead. This potable is usually brought to King Lodbrok when completed, but there is a 1 in 6 chance a barrel containing twenty drafts of the mead is stashed here, awaiting collection.

#### **AREA 1-8—SLAVE MARKET:**

Many tables and chairs are spread about this area, resting atop a broad expanse of dingy red carpeting. Service bars sporting gleaming brass and chrome fixtures stand to the north and south. A dozen cages made from welded steel and lashed together wooden beams dominate the space, each showing signs of regular use.

On market days (see area 1-10 below), another type of bazaar occurs here. The Viking wolfoids sell off their old slaves and recent unwanted captives to buyers from around Epsilon City and beyond. It is rare for true humans to be sold here given the wolfoid proclivity for eating human flesh, but many mutants find their way to the slave market when their owners grow tired of them or they've outlived their usefulness.

When the slave market is open, there are usually 2d20 slaves for sale (use Table 1-2A to determine type) contained in small groups throughout the cages. Twenty Viking wolfoids accompanied by six Viking wolfoid Berserkers keep the peace during the auctions, slaying any who attempt to disrupt the proceedings. They can summon the security bots in the Market (area 1-10 and 2-9) as well as reinforcements.

### **AREA 1-9– NORTH BIFROST ELEVATORS C:**

**A sextet of metal doors, three to either side, stand in the middle of the market. To the north of the doors is a broad set of stairs ascending to the levels above. A group of five wolfoids dressed in chainmail and horned helmets are stationed near the metal doors.**

These elevators and stairs are always guarded by a group of five wolfoids. They allow any wolfoid or creatures accompanied by fellow wolfoids to use the lifts and stairs. All others are warned away with death threats, attacking if these fail to dissuade them.

### **AREA 1-10–THE MARKET:**

**Rows upon rows of tiered seating runs down a shallow slope, ending in front of a raised stage. In the orchestral area before the stage stand numerous tables arranged in rows. Several other tables are displayed on the stage, accessible by a pair of short staircases that flank the performance space.**

This area was formerly an auditorium for performances, but has since become a marketplace run by the Viking wolfoids. In their raids, the wolfoids acquire a great deal of surplus equipment, food, and similar goods. Some of it is stockpiled, while the rest is traded with other residents of Epsilon City. Three times a week, the Viking wolfoids hold a market here to exchange their stolen goods for other items they either cannot produce themselves or desire as luxuries.

There are 5d20 wolfoids present when the market is open and a trio of security robots helps keep the peace. There is a 50% chance one of the Fenrir pups (see area 3-9) is also here during market days, displayed as a symbol of the wolfoids' divine favor.

The tables hold the goods for sale when the market is in business, with each table attended by 1d4 wolfoids.

The Viking wolfoids accept domars as well as bartered goods for their wares. Prices are left to the referee to determine, but the wolfoids drive hard bargains.

Each table has 2d4 useful items for sale in addition to less valuable and/or interesting wares. The referee can randomly determine what each vendor is selling by rolling on the table below and then rolling again on the indicate chart. The referee should ignore any item inappropriate for his or her campaign.

**TABLE 2-3: WOLFOID MARKET GOODS**

| <b>D6</b> | <b>ROLL AGAIN ON THIS TABLE</b>   |
|-----------|---|
| 1-2       | Technological Treasure Item List (1 <sup>st</sup> edition <i>Metamorphosis Alpha</i> rule book, p. 21)      |
| 3-4       | Mutated Substances Treasure Item List (1 <sup>st</sup> edition <i>Metamorphosis Alpha</i> rule book, p. 21) |
| 5-6       | Random Device Generator: Hand Held Devices ( <i>Creatures &amp; Gadgets</i> book, p. 11)                    |

Outsiders are welcomed here while the market is open (12 PM to 6 PM), but anyone starting trouble or caught stealing is dealt with quickly and lethally. The security robots attempt to deal with the troublemakers, but the wolfoids, all of whom have access to many deadly artifacts on their tables, often slay the offenders before the robots can act.

This area is empty when the market is not in session, but the three security robots continue to monitor the area, driving off any creature that attempts to take up residence or damage the furnishings.



## LEVEL 2: EMPRESS FLOOR

### AREA 2-1—HAWKOID NEST:

---

This open-air section contains a plethora of café tables and chairs mixed amongst overgrown decorative plant beds. Pillar-like tree trunks support the ceiling above. Scattered about the area, both in the vegetation below and in the supports overhead, are woven branch nests. Feathered forms flit about the area.

A small tribe of hawkoids live in this former café. There are thirty of the creatures present. The hawkoids are tolerated by the Viking wolfoids and the two species seldom interact directly. The mutant birds avoid agitating their neighbors, but defend their eyrie against intruders.

**Hawkoids** - (30), AC: 8, hp: 40 each, Movement in Spaces: 12 flying/6 walking, Radiation Resistance: 16, CON: 10, Mental Resistance: 14, STR: 10, DEX: 16

**Appearance:** Mutated sparrowhawks, hawkoids stand 4' tall when fully grown. Their legs end in hand-like feet that allow them to use artifacts and weapons while in flight.

**Normal Reaction and Attacking:** Hawkoids have little fear of larger creatures and exist in a near-constant state of hunger. They view any creature that wanders into the territory to be a meal and attack accordingly. Each has a bow (WC 1; dmg 1d6). Two also possess slug projectors (WC 5; dmg 2d6 subdual) with 2 spare clips.

#### **Mutations or Defects:**

**FEAR GENERATION:** A successful mental attack by the creature instills fear in a single opponent. The target must flee from the hawkoid's presence for 3d6 rounds.

**LEVITATION:** The mutant can lift itself vertically without the need to use its wings for up to 25 melee rounds. It can only carry itself and whatever weight it can hold in its hands.

**FORCE FIELD GENERATION:** Hawkoids can create a force field surrounding their bodies that absorb 20 points of damage before failing.

There are three brown bands, a combat helm, two first aid kits, a portable hand dart charger, 5 hydrogen cells, and a chunk of purple honeycomb distributed among the nests. Consuming the honeycomb temporarily gives the eater the *weather manipulation* mutation for 1d6 days.

## AREA 2-2—SOUTH BIFROST ELEVATORS:

---

A quintet of metal doors stands here, the space between them choked with flowing plants and winding vines. A set of stairs climbs and descends to the north of the doors, granting access to the levels above and below. A battered-looking, 8' tall humanoid-shaped robot occupies the area between the pairs of doors. It seems unsteady and lurches occasionally.

The Heimdall Unit stationed here has been damaged by the hawkoids and not been repaired. It is now unpredictable and both the wolfoids and hawkoids avoid using these elevators and stairs.

The security bot is 25% likely to attack any creature coming into its sensor range, 50% likely to ignore it entirely, and 25% likely to operate according to its re-programmed commands (as in area 1-4 above). It has stats identical to the Heimdall Unit in area 1-4 but with only 75 hit points remaining and its energy shield is disabled.

### AREA 2-3—NIGHTCLUB:

---

A twisted maze of overturned tables and chairs fills this area. Winding vines and man-sized fern-like plants grow amongst the toppled furnishings, making it difficult to see into the heart of the space. An occasional colored ray of light or shimmering reflection shines from the myriad of strange protuberances that extend from the ceiling.

This former recreational area is overgrown with mutant vegetation, former decorative plants run amok. Movement through this area is difficult and all PCs move as if encumbered with plate and shield despite their true armor and belongings.

Despite appearances, the vegetation is not separate plants, but growths of a single, massive plant located deep in the former club. Attacks directed at the various fern-like growths and vines can hurt the plant, but only destroying its main bulb can slay the massive mutation.

**Flash Plant** - AC: 8 (central bulb: 5), hp: 100 (main bulb), 25 (each separate growth); Movement in Spaces: 0, Radiation Resistance: 025 (each separate growth), Radiation Resistance: 12, CON: 17, Mental Resistance: 13 (see below), STR:14, DEX: 17

# ASGARD APARTMENTS

## Map 2: Empress Floor

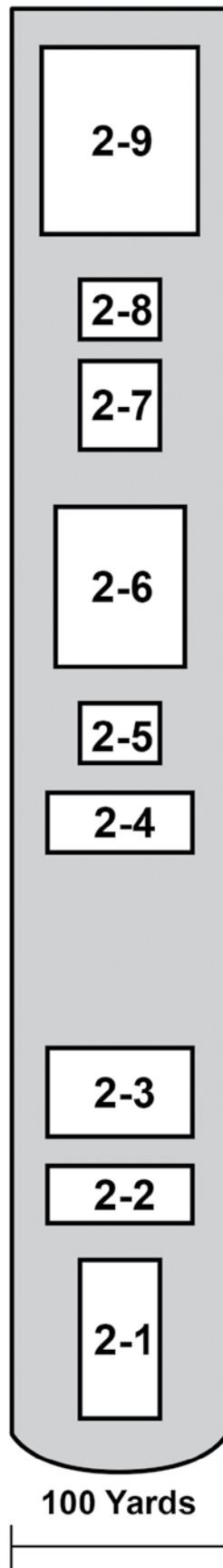

## AREA 2-4—BOT MAINTENANCE:

---

**Appearance:** The flash plant appears as a collection of twisted tendrils with small blossoms and a number of fern-like growths, all of which seem unconnected at first glance. It is only with close study that one can see these are all parts of a greater whole. The center of the plant is a large bulbous growth covered in bark and dripping sap.

**Normal Reaction and Attacking:** The flash plant uses its pheromone pollen to attract prey deep within its winding maze before attacking. It pins its prey with its vines and then uses its sunflowers to cook its quarry before dragging the charred remains to the central bulb to decompose and feed its roots.

### **Mutations or Defects:**

**AROMATIC POWERS:** The plant produces pollen equal to Strength 10 poison. Any creature affected by the pollen are unable to do anything for four melee rounds except wander deeper into the plant's domain. Creatures affected by the aromatic pollen is automatically hit by the plant's vine attacks.

**SQUEEZE VINES:** These tendrils are WC 3 and inflict 4d6 damage on a successful strike and each subsequent round. They also immobilize their victim until the vine is severed (AC 8; 15 hit points).

**SUNFLOWERS:** The plant possesses many small flowers that produce rays of concentrated light capable of burning flesh. It can fire up to twenty of these beams each round. Each ray strikes as WC 2 and inflicts 1d6 damage on a successful hit.

**STROBE LIGHT:** The plant can produce a variable rate strobe effect that impedes attacks directed at it. Any creature relying on sight to attack suffers a -3 penalty to all physical attack rolls.

**CENTRAL BRAIN:** The plant's brain is situated in its central bulb. Mental attacks directed against its vines or fern clusters have no effect. Only those attacks targeting the central bulb (which must be seen by the attacker) have a chance of succeeding.

A small raised stage that once served as a performance space now contains the central bulb of the labyrinthine vegetation that crowds the area. Its vines collect the belongings of its meals and gather them here. Currently the plant has a hoard consisting of an energy armor shield, an EMP pistol, 47 domars, a wooden shield, a pair of battle gloves, and a paralysis dart projector with 10 uncharged darts.

The light-producing protuberances in the ceiling are simple stage and dance floor lighting that still function.

**Blinking consoles and tool-covered tables fill this area and mechanized arms bearing weird tools dangle from tracks on the ceiling. A pair of box-shaped robots roll around the area, devices gripped in their metal tentacles.**

This area maintains and repairs the various robot units of the apartment complex. The two boxy robots are engineering bots specially designed to repair their robotic counterparts. The robots ignore non-robotic creatures unless presented with a gray color band, in which case they turn their attention to the bearer and await orders.

Robotic units entering this area are quickly attended to by the engineering bots and the mechanized repair arms in the ceiling. Robot PCs will be healed to full health in 1d4 hours if they allow repairs to be made to them.

Most of the tools and parts present here are highly-specialized and useless to explorers. The engineering bots have also become slightly obsessive compulsive and will try to reclaim any object taken from its proper place. If directly attacked, the units can summon a security bot that arrives in 2d4 rounds to stop the assault.

## AREA 2-5—CENTRAL BIFROST ELEVATORS:

---

**A quartet of metal doors, a pair to either side, flanks a wide corridor. At the end of the hallway is a broad set of stairs leading to the levels above and below. Burning torches light the corridor and stairs. Standing in the corridor between the metal doors is an 8' tall humanoid shape of pure white that bears a single golden eye in the center of its head. The creature gazes at you unblinking.**

These elevators are guarded by a Heimdall Unit that functions identically to the one in area 1-4 above.

## AREA 2-6—GARDEN:

---

**The light is brighter in this wide-open area. Shafts of golden sunlight pour down on a large grove of trees growing amongst heather and gorse. Rocky outcrops turn the floor into a series of rising tiers and a babbling stream pours in cataracts from one elevation to the next before ending in a clear pool at the center of this beautiful yet raw garden.**

This artificial garden was designed to mimic the natural landscape of Norway's Nordmarka Forest. The trees are a mixture of beeches and pines, not all of which were unaffected by the radiation cloud. The sunlight and sky are both artificial.

This area is now used as a proving ground for young warriors. They must survive a day and a night in the garden in order to be considered worthy of participating in their first raid.

The garden is home to 20 mutant squirrels called ratatoskrs.

**Ratatoskrs** - AC: 4, hp: 25, Movement in Spaces: 8/10 climbing, Radiation Resistance: 16, CON: 8, Mental Resistance: 8, STR: 4, DEX: 15

**Appearance:** Ratatoskrs resemble normal Eurasian red squirrels, albeit of dark green coloration. They are otherwise indistinguishable from their unaltered forebearers.

**Normal Reaction and Attacking:** Ratatoskrs are territorial creatures, but they allow other mutants to briefly remain in their territory unmolested. Any creature that stays in ratatoskr grounds for more than an hour are attacked unless they appease the mutant squirrels.

**Mutations or Defects:**

**LASER EYES:** Ratatoskrs can produce rays of blue, high-intensity light from their eyes. These attacks are Weapon Class 6 and cause 6d6 damage on a successful hit.

**NATURAL MIMICS:** Ratatoskrs can reproduce any sound they've heard and use this ability to lure intruders into ambushes.

**TOTAL HEALING:** A ratatoskr can cure itself of all damage once per day. This mutation affects poisons and ongoing diseases as well.

**ENTRANCED BY RYTHMN:** Any rhythmic noise lasting longer than 1 melee round has a chance of entrancing all ratatoskr within 60 feet, lulling them into immobility. This is resolved as a mental attack with a Mental Resistance of 12 versus the mutant squirrel's Mental Resistance of 8. If successful, the ratatoskrs can do nothing but listen to the rhythmic sounds. They fall asleep if the sounds continue for an hour or more.

---

## AREA 2-7—SAUNA:

---

**This space is lined with dark wood walls and raised benches run along the perimeter of the room. Several waist-high pedestals stand around the chamber, glowing with red light. A small control panel is affixed to each glowing plinth. The air is humid and the temperature is much warmer than outside.**

This sauna was once a popular feature of the apartments, a means to purify the body and restore the spirits. It can now be either a medicinal wonder or a deadly trap.

Altering the settings on the control panels raises the temperature of the sauna and activates medicinal infusers that impart beneficial qualities to the steam. The steam and heat is created by the glowing pedestals and released into the room. If the Complexity 5 controls are successfully deduced, any creature spending 20 minutes or more in the relaxing steam bath regains 2d6 hit points. Additionally, if any creature is suffering from poison, the steam reduces the poison's Strength by 1d6 and the Poison Chart is consulted once more. If the poisoned creature is no longer affected by the reduced Poison Strength, he sweats out the toxin and its effects are neutralized.

Any failed attempt to operate the sauna's controls immediately raises the temperature here to parboiling levels, inflicting 5d6 points of damage each round to all in the area.

---

## AREA 2-8— NORTH BIFROST ELEVATORS:

---

**A sextet of metal doors, three to either side, stand in the middle of the market. To the north of the doors is a broad set of stairs ascending to the levels above. A group of five wolfoids dressed in chain-mail and horned helmets stand alert near the metal doors.**

These elevators and stairs are always guarded by a group of five Viking wolfoids. They allow any wolfoid or creatures accompanied by fellow wolfoids to use the lifts and stairs. All others are warned away with death threats and attacked if they fail to depart.

## AREA 2-9— MEZZANINE:

---

**A large balcony filled with tiered seating overlooks a performance space below.**

When not needed in area 1-10 below, the auditorium's three security bots are stationed here. They provide security when the market (area 1-10) is open and keep vermin and other menaces from taking up residence when the market is closed. The bots ignore the PCs unless they attack the robots, cause damage here or in area 1-10, or attempt to set up camp on the balcony. The Viking wolfoids can also summon them as needed.

### **Security Bots (3)**

Aside from the three robots, this area contains nothing of interest.

## LEVEL 3: VISTA FLOOR

### AREA 3-1—JARLDOM OF GUNNHILD

---

This section of the complex houses Jarl Gunnhild and her 100 followers. Jarl Gunnhild leads the smallest number of Viking wolfoids, mainly due to the fact she is relentless in battle and often leads near-suicidal raids. Her ferocity and boldness is due to her constant need to demonstrate her alpha status amongst the male-dominant woldoid society. Jarl Gunnhild is respected by King Lodbrok, but he considers her a near-wild animal whose actions will eventually lead to her death.

Jarl Gunnhild leads a personal guard of 20 shield maidens (female woldoid Berserkers) who will gladly lay down their lives for their Jarl. Outsiders joining her ranks will have different experiences based on their genders: woman will be treated with elevated respect and greater privilege, while males will find themselves force into the most potentially-lethal roles during raids.

Lately, Jarl Gunnhild has learned of the Pirate wolfoids' strange attitudes towards females, one that puts them at a severe disadvantage in battle. Gunnhild is currently dreaming of leading a raid against the Pirate Apartments with a goal of claiming them as her own and setting herself up as a Viking Queen to rival King Lodbrok.

## AREA 3-2—COMMON AREA:

---

**Flaming brands and a burning fire pit illuminate this space, filled with comfortable-seeming furnishings that look out of place amongst the rustic environs. A raised platform bearing a steel throne overlooks the tables and chairs. A pair of crossed axes flank an octagonal shield behind the throne. Along the edge of the raised platform are a number of spikes, each adorned with the rotting head of a slain enemy.**

There are always 1d10+10 Viking wolfoids present in this area at any time, drinking, feasting, and gaming. Almost all are female, but a small number (10%) are males. The males are particularly reckless in battle should a fight occur. In addition to the wolfoids, 3d6 slaves of various species (see Table 1-2A above) are here serving their needs. The Vikings menace intruders, especially if they're male, but will parley with female PCs, showing politeness towards them and allowing them to state their business in this area. Particularly eloquent or bold females might be brought before Jarl Gunnhild and given the opportunity to join her numbers.

The axes are well-made metal weapons that grant a +1 to attack rolls and deal 1d10/1d10/1d12 damage in battle. The shield is a rare powered defensive item. It is treated as a duralloy shield for AC purposes but can also project a force shield identical to the *force shield generation* mutation. The shield is powered by a single hydrogen cell and can create up to six force shields before being exhausted.

### AREA 3-3—SOUTH BIFROST ELEVATORS:

---

**Metal doors flank a short corridor at this location. A broad staircase climbs and descends to the north.**

This area is seldom guarded and only sparsely used. There is a 1 in 6 chance of encountering 2d6 Viking wolfoids here when exploring this section, but there are otherwise no guardians present.

# ASGARD APARTMENTS

## Level 3: Vista Level

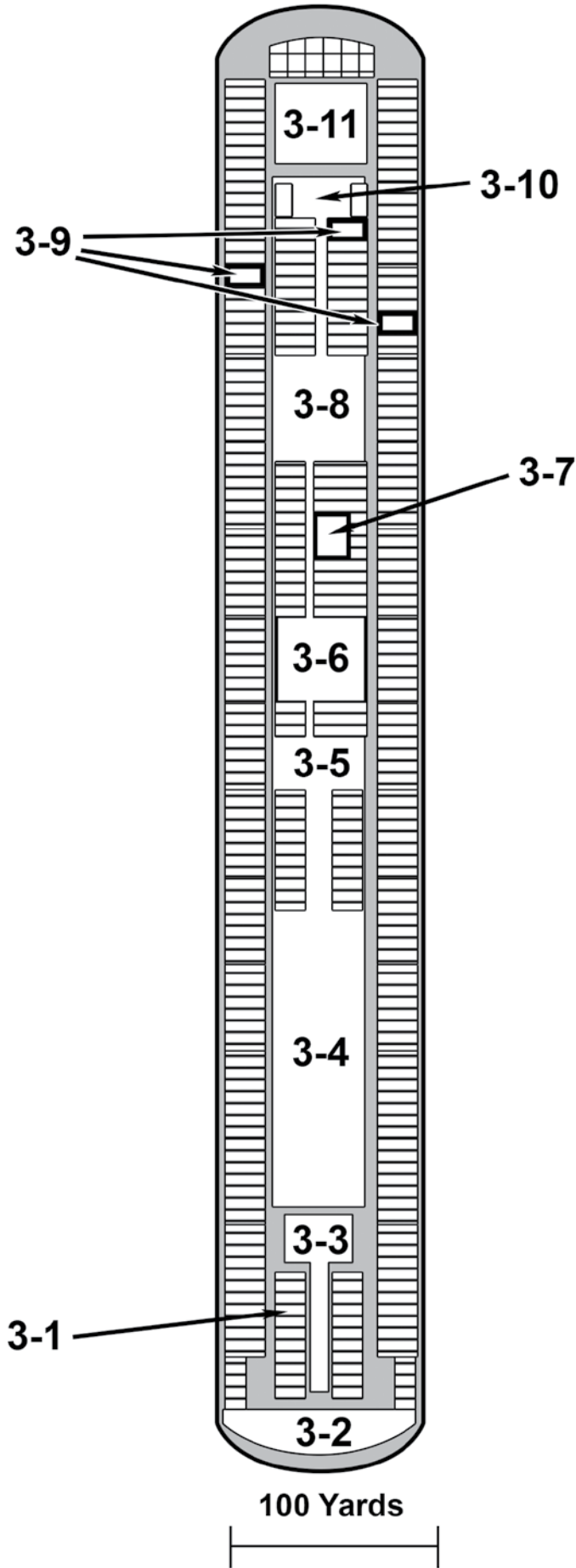

---

## AREA 3-4—TRAINING FIELD:

---

A long, broad field stretches for nearly two hundred yards here. Rope-enclosed sparring fields, archery targets, and other training facilities occupy the field. The clash of arms and the howls of battle erupt for the many giant wolf-like creatures present.

The Viking wolfoids constantly hone their battle skills, preparing for the great conflict of Ragnarok. There are always 1d20+20 wolfoids found here, sparring and practicing. On occasion, slaves serve as living targets for their bloodlust and captured PCs might be turned loose in this area and hunted by wolfoid Berserkers.

Amongst the training gear are 20 battle axes, 15 swords, 15 throwing spears, five chainmail byrnies, two sets of berserker's byrnies, and a first aid kit.

---

## AREA 3-5—CENTRAL BIFROST ELEVATORS:

---

**Metal doors flank a short corridor at this location. A broad staircase climbs and descends to the south. A group of horned-helmeted wolfoids stand watch over the doors.**

Five wolfoids are stationed here, assigned to watch these elevators as punishment for a minor infraction. They are surly and looking to take out their rage on anyone unlucky enough to give them reason to.

---

## AREA 3-6—JARLDOM OF ULF

---

These apartments are home to Jarl Ulf and his 275 wolfoid followers. Jarl Ulf currently has the best standing with King Lodbrok due to the many successful raids he and his warriors conduct throughout Epsilon City. Jarl Ulf leads a group of 30 wolfoid berserkers in battle, each of whom wears a berserker's byrnie and carries a vibro batlleaxe.

Most of the interior apartments in this section are occupied by Jarl Ulf's followers and their slaves. Jarl Ulf and his berserkers dwell just beyond area 3-7, which serves as the common room for this section's occupants. Jarl Ulf holds court here and lavish feasts are often enjoyed by the Jarl's followers.

---

## AREA 3-7—COMMON AREA:

---

Many long wooden trestle tables and benches fill this space, an area adorned with painted wooden shields and numerous furs. A roaring fire burns in a centrally-located fire pit, illuminating the area.

There are always 1d20+20 Viking wolfoids present here, dining, drinking, boasting, or planning their next raid. Jarl Ulf is 50% likely to be encountered here with 3d10 of his berserkers if the PCs penetrate this far into his Jarldom undetected. Interlopers are met with barely-restrained violence, allowing the newcomers a brief window to parley with the wolfoids. If they can win the Viking wolfoids over with their words or deeds, they may be given the chance to join Jarl Ulf's followers.

The shields are normal wooden ones and the fire is a hologram that produces light but no heat or smoke. The furs are from a variety of mutant creatures and are worn and well-used. They have little monetary value, but can be used as decoration or made into warm clothing.

---

## AREA 3-8—NORTH BIFROST ELEVATORS:

---

**A sextet of metal doors, three to either side, flank the corridor. To the north of the doors is a broad set of stairs lending access to the levels above and below. Standing near the metal doors is an 8' tall humanoid shape of pure white that bears a single golden eye in the center of its head.**

A final Heimdall Unit stands watch over these elevators. It behaves as its counterpart in area 1-4 above.

---

## AREA 3-9—LESSER JARLDOMS

---

The apartments in this section are home to five other minor jarls and their followers. They number roughly 700 in total and are divided into small enclaves separated by empty apartments throughout the region. Each of the jarls is eager to increase his or her status in the eyes of King Lodbrok and might cut a deal with outsiders if they see a means to advance themselves in the Viking wolfoid society.

This wide-open space is decorated with countless weapons and shield hanging on the walls. Most of these objects are crudely made, but a handful appear to be of more competent construction. A towering wood statue dyed a deep crimson dominates the northern portion of the area. The statue depicts a great wolf crouched on all fours, soundlessly growling. A crudely-carved human hand the size of a large boulder is clamped in the wooden wolf's jaws.

The Viking wolfoids gather here before raids to receive the war-blessing of their god. The weapons on the walls are trophies taken in battle from lesser species and are predominantly of primitive manufacture. There are more than 200 spears, 75 clubs, 35 swords, and 80 stone daggers. The shields are mostly wicker or plant-fiber in construction.

This area is home to three mutant Fenrir cubs, offspring of the great Father Wolf that prowls the wilds outside of Epsilon City (see the adventure *Fimbulwinter* for more details on this mutant and the Viking wolfoids' plans for it). There is also a 50% chance 3d6 Viking wolfoids and 1d6 wolfoid berserkers are here paying homage to Fenrir when this area is first entered.

**Fenrir Pups** (3), AC: 7, hp: 80 each, Movement in Spaces: 15, Radiation Resistance: 14, CON: 15, Mental Resistance: 13, STR: 17, DEX: 14

**Appearance:** Fenrir pups are massive wolf pups, measuring 40' from nose to tail and standing 18' tall at the shoulder. Each weighs 3,000 lbs. Their coloration is dark brown, nearly black, with white underbellies, noses, and tails. One has a red blaze between its eyes.

**Normal Reaction and Attacking:** The Fenrir pups are young creatures and are prone to quickly vacillate between playfulness and aggression. They are curious about any creature coming into this area and meet canine-mutants with playful friendliness. Other creatures they approach with more caution. If they are startled or injured, they immediately tear the source of harm to shreds. The pups bite (WC 9; dmg 20 points) and then worry their prey (automatic additional 3d6 damage).

**Mutations or Defects:**

**CRYOGENICS:** The pups can create an aura of cold surrounding them that causes damage to all within 20'. This damage starts at 1 die and increases by another die each subsequent round until it freezes opponents solid after 10 rounds. The pup does not need to concentrate to invoke this power and can attack normally with its bite.

A cavernous room containing row after row of seats facing an elevate stage is located here. Burning torches provide flicking light, illuminating a grand throne of rough timber decorated with hunks of amber and soft furs dominating the stage. A number of smaller seats flank the throne. Upon the walls hang colorfully-painted round shields mixed amongst the skulls and skins of animals, mutants, and men.

This space serves as King Lodbrok's audience chamber and doubles as the meeting hall for the complex's sporadic Things (councils of the jarls). It is empty most of the time, but there is a 1 in 6 chance a meeting is underway when the PCs are exploring this level. In this case, there will be 100 Viking wolfoids, 20 wolfoid berserkers, and King Lodbrok present. They are likely to be unfriendly to unannounced visitors and attack immediately, seeking to capture rather than kill, so that they can make the intruders suffer at their leisure.

**King Lodbrok** - AC: 1, hp: 100, Movement in Spaces: 10, Radiation Resistance: 14, CON: 18, Mental Resistance: 16 (18), STR: 18, DEX: 18

**Appearance:** King Lodbrok is an exceptionally large and robust wolfoid. He wears a berserker's byrnie and a combat helmet adorned with horns. This helmet gives him infrared vision and increases his mental resistance to 18.

**Normal Reaction and Attacking:** King Lodbrok is a fearsome warrior and has no fear of death. Not one to cower in the rear, he leads his warriors by example, reveling in blood and battle. Despite his ferocity, King Lodbrok is also a cunning strategist and will gladly deal with outsiders so long as he sees a way to gain from such dealings. He is armed with a pair of throwing axes (WC 1; dmg 3d6+6) and a vibro battleaxe (WC 9; dmg 40+1d6+6).

**Mutations or Defects:**

**FLAME RESISTANT FUR:** The creature is immune to fire and heat damage of all type.

**INCREASED STRENGTH:** Viking wolfoids are extremely strong and add +6 to all melee damage rolls

**REGENERATION:** The creature heals 5 hit points per round until slain.

**NATURAL WARRIOR:** King Lodbrok has all the advantages of the Military Genius mutation (+4 to hit and +1 die of damage) plus he grants his wolfoid followers an additional +1 die of damage to all their melee attacks so long they can see him.



The decorations on the wall are mostly ornamental, but behind a ragged cougaroid pelt to the left of the throne is a small metal vault door. A red color band opens the door. Once a security locker, the space now holds King Lodbrok's treasury. Inside are three foot-lockers containing 6,000 domars, a case holding 10 vibro battleaxes, three suits of berserker's byrnies, six casks of Fenrir's Mead (20 uses each), 5 white color bands, 10 brown color bands, 3 gray color bands, a suit of light mobile scout armor, a box of 10 sonic grenades, a first aid kit, and a slug rifle (type 4) with 1,000 rounds of ammunition.

## LEVEL 4: LIDO FLOOR

This floor is avoided by the Viking wolfoids. None of the elevators are guarded and only occasionally do warriors venture here at the behest of King Lodbrok. So far, none of those fierce warriors have returned...

### AREA 4-1—OSCILLATING RADIATION FIELDS:

**Strange colors seem to writhe in the gloom before you, shifting through the spectrum in a slow crawl and bathing the space in a rainbow of shimmering light. There appears to be no source to these constantly-changing colors. Your skin tingles for reasons you cannot fathom.**

A band of cosmic radiation, residue from the weird stellar cloud that decimated the *Warden*, remains trapped in this area. It, too, has undergone strange changes since the catastrophe long ago. The Intensity 13 radiation affects different creatures in unpredictable ways.

True humans exposed to the radiation take damage as normal if the weird energy overcomes their Radiation Resistance score. Mutated humanoids gain hit points equal to the damage they might otherwise suffer. These hit points are temporary and last until lost from injury or one week passes. Mutated Creatures never suffer damage, but automatically gain a new mutation if they are affected by the radiation. This mutation is always a physical one and randomly determined by a roll on the Physical Mutation List (see *The Mutation Manual*, pp. 1-2). A Mutated Creature can only receive one mutation per week; further exposure to the radiation during this period has no effect.

### AREA 4-2—ARTIFICIAL FJORD:

**The rocky walls of this space plunge sharply down to a narrow bay. A small rustic fishing village stands on the rocky northern shore beside the blue water. The smell of salt is strong in the air and, instead of a ceiling, an azure blue sky rests overhead.**

This space is designed to resemble a Scandinavian fjord and was used as a fishing and recreational boating area before the catastrophe. The waters were stocked with a number of game fish, some of which were changed by the cosmic radiation and now command the depths of the fake fjord.

The 25' deep saltwater fjord is home to the scaleings, a race of mutated herring, who dwell in bubble-shaped homes beneath the surface.

**Scaleings** - AC: 4, hp: 50 each, Movement in Spaces: 8/12 in water, Radiation Resistance: 13, CON: 12, Mental Resistance: 12, STR: 14, DEX: 10 (on land)/16 (underwater)

**Appearance:** Scaleings are humanoid herring with silvery scales and fin-like arms and legs. They stand 5' tall and carry spears, daggers, and the occasional artifact.



# ASGARD APARTMENTS

## Level 4: Lido Level

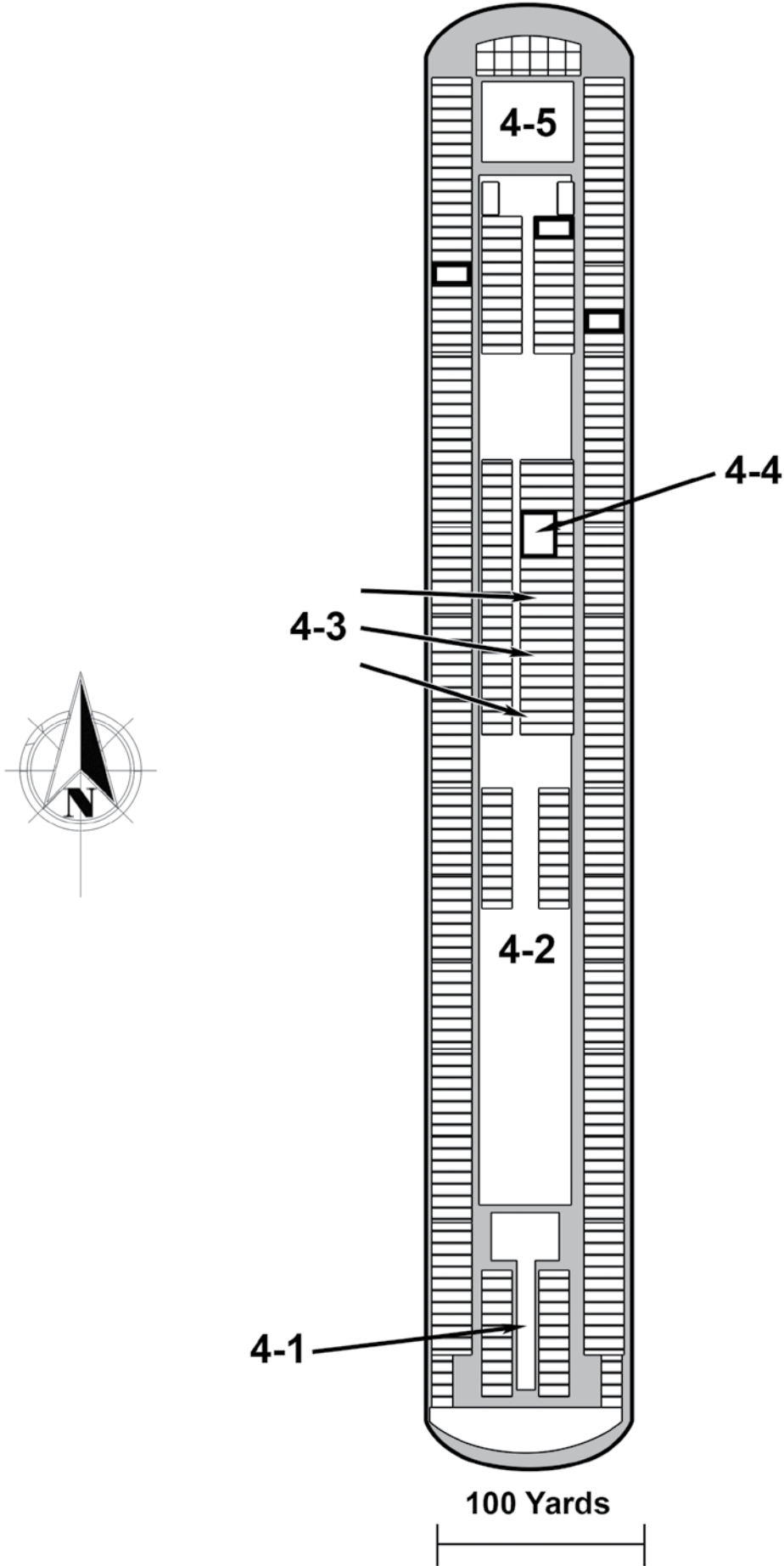

**Normal Reaction and Attacking:** The scaleings consider this entire area their home and will attempt to drive off intruders with threats and warning shots. Scaleings are fascinated by shiny metal objects, however, and they will agree to allow outsiders to pass through or rest here in exchange for sparkly curiosities. They use spears and daggers in battle.

**Mutations or Defects:**

**AMPHIBIOUS:** Scaleings can spend up to six hours outside of water as they possess special water-filled sacs from which to draw oxygen. These sacs also make them immune to gas-based attacks.

**ELECTRICITY GENERATION:** The creature can cause 3d6 points of electrical damage with a successful WC 2 melee attack.

The scaling village is comprised of a dozen huts holding the mutant fishmen's treasures. Within these buildings are a sensory intensifier, two underwater breathing lungs, a medical hand analyzer and healer, six hydrogen cells, a broken tiger decoy, and 64 domars.

The shoreline village contains six empty buildings resembling Viking homes. Any goods they one had are long gone, but they are structurally sound.



**Functioning ceiling lights become less regular as you move towards this section of the building. Dark panels become more frequent and the air grows cooler. Dirt and debris clutter the corridor and it is apparent that few creatures venture here. Painted on the hallway wall is a message in crimson-colored pigment: “Hel is beyond this point.” The air is still and silent.**

This entire section of the complex is disused and largely avoided by the apartments' occupants. Even the complex's robots no longer maintain this region. There is no illumination here aside from the ambient light coming through the apartment windows. At night, the entire area is dark. The environmental control units have long since malfunctioned, and this portion of the complex varies in temperature from uncomfortably hot to numbingly cold—sometimes changing from one to the other in a matter of minutes. The Viking wolfoids, drawing upon the adopted mythology, call this section “Hel.”

PCs venturing further into this section discover that the apartments become a tangled maze. Furniture, wall sections, and other obstacles obstruct the corridors, detouring visitors into apartments only to find that crude doorways have been hacked through adjoining walls, further confounding travelers.

Explorers in this region have a 3 in 6 chance of encounter a band of 2d6 grendels every hour they spend here. The grendels seek to attack from ambush and surprise intruders on a 4 in 6 chance unless their prey possesses mutations capable of detecting them before they strike.

**Grendel - AC: 7, hp: 60 each, Movement in Spaces: 12, Radiation Resistance: 12, CON: 14, Mental Resistance: 14, STR: 17, DEX: 16**

**Appearance:** Grendels, being constructed from stolen organic material and DNA, vary in appearance. All are loping, gangrel creatures, disfigured as if poorly assembled by an indifferent creator. Roll 1d8 to determine the basic appearance of an encountered Grendel: 1) Wolfoid; 2) Reptilian; 3) Amphibian; 4) Piscine; 5) Insectile; 6) Humanoid; 7) Avian; 8) roll again twice and combine results.

**Normal Reaction and Attacking:** Grendels are very protective of their brood mother. They treat any who enter the labyrinth as threats to be killed, consumed, or brought to the brood mother as tribute. They prefer

to attack from ambush, using their familiarity of Hel's labyrinth to surprise their enemies, doing so on a 4 in 6 chance. Grendel are semi-intelligent and use simple tools such as clubs, spears, axes, and shields.

#### **Mutations or Defects:**

**HEIGHTENED STRENGTH:** The grendels inflict an addition 3 dice of damage when using non-powered weapons.

**HEIGHTENED SPEED:** Grendels attack twice each round and can move twice their normal movement rate in open areas.

**RANDOM MUTATION:** Given their diverse DNA, each grendel may also possess an addition physical mutation if the referee so desires. This makes them unpredictable opponents and should put some fear in the players.

---

### **AREA 4-4—BROOD MOTHER HABITAT:**

---

**The air smells rancid and is thick with the stench of rotting organic matter. Slick pools of slime are splattered everywhere in this unlit place. Odd-shaped fragments of what appears to be ceramic material stand in drifts in corners. A low, murmuring hum sounds at the very reach of hearing.**

The grendel brood mother, a mutated mass of flesh and metal, resides in the center of this area. From here it sends out its minions and concocts new monstrosities from the organic matter and DNA these servants harvest. It always guarded by 10 Grendel who gleefully die in defense of their brood mother.

**Grendelmor Brood Mother** - AC: 3, hp: 150, Movement in Spaces: 3, Radiation Resistance: 15, CON: 30, Mental Resistance: 18, STR: 20, DEX: 5

**Appearance:** The Brood Mother is a noisome mass of dark, diseased-looking flesh that slouches upright like a soft stalagmite. Patches of wiring and circuit boards are visible amongst the doughy flesh and flickering lights seem to pulse just beneath the creature's skin. Several fleshy ovipositors extend from the creature, birthing cocoons filled with embryonic grendels.

**Normal Reaction and Attacking:** The Brood Mother can only move slowly and is cared for by her army of minions. If the PCs have reached the heart of the grendel hive, the brood mother attacks them without mercy, seeking to eradicate them before they slay it. The brood mother sends her servants at the party in suicidal attacks while it supports them with its array of mutations.

#### **Mutations or Defects:**

**SLIME:** The brood mother can excrete a 10' square patch of slick slime up to 30' away. Any creature in the area of effect must roll its Dexterity score or less on 4d6 or fall prone.

**RADIATION BEAMS:** The mutant blasts up to 3 targets within 40' with bursts of Intensity 14 radiation.

**LIFE LEECH:** The brood mother can drain 6 hit points every melee round from all creatures within a 70' diameter centered on it. These points are added to its own hit point total.

**CREATE GRENDEL:** Four times per day the brood mother can ingest organic matter and genetic code brought to it by a grendelmor and recombine that material to create an embryonic mutant. The nascent grendel is encased in a hard cocoon resembling dark ceramic material and then excreted by one of the brood mother's ovipositors. The newborn grendel come to term 1d6 days later, hatching from its cocoon as a full adult mutant capable of caring for itself and serving the brood mother as needed.

Mixed amongst the broken cocoon shards are trinkets including a sonic metal disruptor, a laser torch, a red band, a green band, a security hand unit, and a pair of paralysis rods.

---

### **AREA 4-5—GYMNASIUM:**

---

**Odd machines and unidentifiable contraptions fill this space. The walls here are not the wood timbers found elsewhere, but mirrors dulled by age and neglect. Brightly lit panels in the ceiling illuminate the area clearly, but the sheer number of devices present makes it impossible to view the entire large room from your vantage point.**

Once a gymnasium and workout area, this neglected space is now home to a strange menace. This mutation is of unknown origin and may be unique on the *Warden*: the growdie.

**Growdie (1)** - AC: 5, hp: 55, Movement in Spaces: 14, Radiation Resistance: 18 CON: 14, Mental Resistance: 8, STR: 18, DEX: 13

**Appearance:** The growdie resembles an asymmetrical, 8' diameter lump of sponge that rolls and crawls about the place. Its spongy flesh occasionally splits apart to reveal a gleaming eye or drool-filled mouth. Debris, dust, and other matter cling to its soft, sticky skin, making it resemble a pile of trash when immobile.

**Normal Reaction and Attacking:** The growdie is attracted by heat, both that produced by living creatures and energy-powered devices such as artifacts and robots. It is universally omnivorous, capable of consuming almost any matter, making it an unbiased hunter. Anything that produces heat and enters its territory is considered food. It attacks with its mutations and its bite (WC 3, dmg 1d10/1d10/1d12)

**Mutations or Defects:**

**PHYSICAL FLINGING BACK:** Within 10 rounds of suffering damage from an attack, the growdie can throw back that exact same damage to any creature within sight. This power may be used once per day.

**PLIABLE:** The growdie can squeeze through an opening the size of a quarter given enough time (5-10 minutes).

**DISSOLVING MUCUS:** With a successful WC 2 melee attack, the growdie splashes its prey with an acidic slime that inflicts 20 points of damage.

**HEAT DIET:** The growdie thrives on heat and gains health from heat-based attacks. If struck with a fire or heat attack, the growdie gains temporary hit points equal to the damage inflicted. These hit points last until lost to injury or 24 hours have passed.

The gym contains various physical exercise devices, most of which have been damaged by the growdie. Scattered about are a few objects formerly carried by the creature's victims, but left undigested by the growdie. These include six spears, four wooden shields, a suit of plastic armor (AC 3), 47 domars in a woven pouch, a folding shovel, and a canteen filled with glowing blue liquid. The liquid is Intensity 12 radioactive material.

## LEVEL 5: SKY FLOOR

### AREA 5-1—BUZZER HIVES:

Several squat transparent pillars are placed about the lush green garden that covers much of the rooftop. Within the transparent walls of each are waxy, beige panels of some sort. In several of the pillars, this waxy substance emerges from narrow slits atop each, giving the object a lumpy appearance. The air hums with the sound of insect's wings.

Ten apiaries are staggered about this rooftop meadow that once served as the playing field for various sports. The artificial hives are home to 1,000 buzzers who dwell here placidly so long as creatures with active mental mutations keep their distance. The Viking wolfoids carefully harvest the buzzer's honey to make their special Fenrir's Mead.

**Buzzer Swarm AC:** 7, hp: 30 Movement in Spaces: 12 flying, Radiation Resistance: 12, CON: 6 Mental Resistance: 12, STR: 3 DEX: 18

**Appearance:** A cloud of angrily swarming honey bees with green and black coloration. There are at least 50 bees in the swarm.

**Normal Reaction and Attacking:** Buzzers ignore visitors to the roof, content to harvest nectar from the flowering plants on the complex's balconies. However, any use of a mental mutation within 200' of their hives angers them, causing 1d6 swarms to descend upon the offending mutant. Each swarm directs 2d6 mental blasts (see below) every round at the creature(s) whose mental energy angered them.

**Mutations or Defects:**

**MENTAL BLAST:** Buzzers can expend a high-intensity mental blast that does 4d6 damage to its target. The effort to create this blast knocks the buzzer unconscious for 3d6 minutes. Each swarm can create up to 50 blasts before all its component creatures are rendered unconscious.

### AREA 5-2—VIKING SHIP TRANSPORTS:

A motley collection of vehicles are parked on this expanse of open rooftop. Each is a sleek, metallic craft bearing many windows and two large side doors. All of the vehicles show signs of modification: crude wooden prows decorated with dragon heads are affixed to the front of each craft and a snaky serpent's tail graces the rear of the vehicle. Shields

## ASGAARD APARTMENTS

### Level 5: Sky Floor

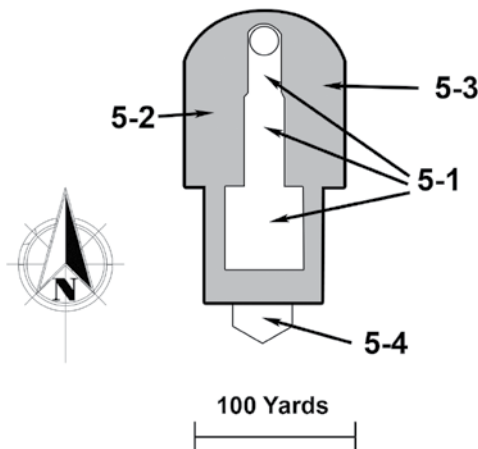

line the sides of the transports, providing armor and protecting the numerous windows from attack.

There are twenty air transports present, all of which are used by the Viking wolfoids on their raids around Epsilon City. Most of the craft bear laser burns, broken windows, and similar damage incurred during raids, but function perfectly. While the wolfoids claim them as their property, any creature able to deduce the craft's operation (Complexity 8) can command it to take them anywhere in or around Epsilon City as they desire.

### AREA 5-3—RELAXATION POOLS:

A half-dozen small pools sit embedded in a stretch of cracked and uneven duracrete. Wisps of steam rise from the pools bubbling surfaces and a strange odor that lightly stings the nose hangs faintly in the air. Three tall, gnarled trees with twisted boles and drooping branches crowd near the pools, their roots plunging into the cracks in the duracrete beneath them.

These hot tubs range from 3' to 4' in depth and function normally. The odor is chlorine and it may be un-

familiar to the PCs. The trees are a mutated species known as grabbing junipers, their windborne seeds carried here long ago. The wolfoids keep clear of this area, but the complex's maintenance robots are untroubled by the trees due to their inorganic nature.

**Grabbing Junipers (3)** - AC: 8, hp: 80 each, Movement in Spaces: 0, Radiation Resistance: 16, CON: 18, Mental Resistance: 10, STR: 15 DEX: 10

**Appearance:** These twisted trees are mutated junipers, possessing long, dangling branches and wind-twisted trunks. They have up to 100 bright orange seed cones hanging from their branches.

**Normal Reaction and Attacking:** Grabbing junipers are carnivorous, feeding on the decaying flesh of organic creatures. These particular trees have learned how to use the hot tubs to quickly dispatch prey and absorbed their rotting flesh through their adjacent root system. Any organic creature approaching within 30' of the trees is grabbed by their branches and plunged into one of the hot tubs. The grappled mutant will drown in a number of rounds equal to half its Constitution score (the branched further squeeze the breath from the victim, accelerating the drowning process) if not freed. Each branch is AC 5 and has 25 hit points.

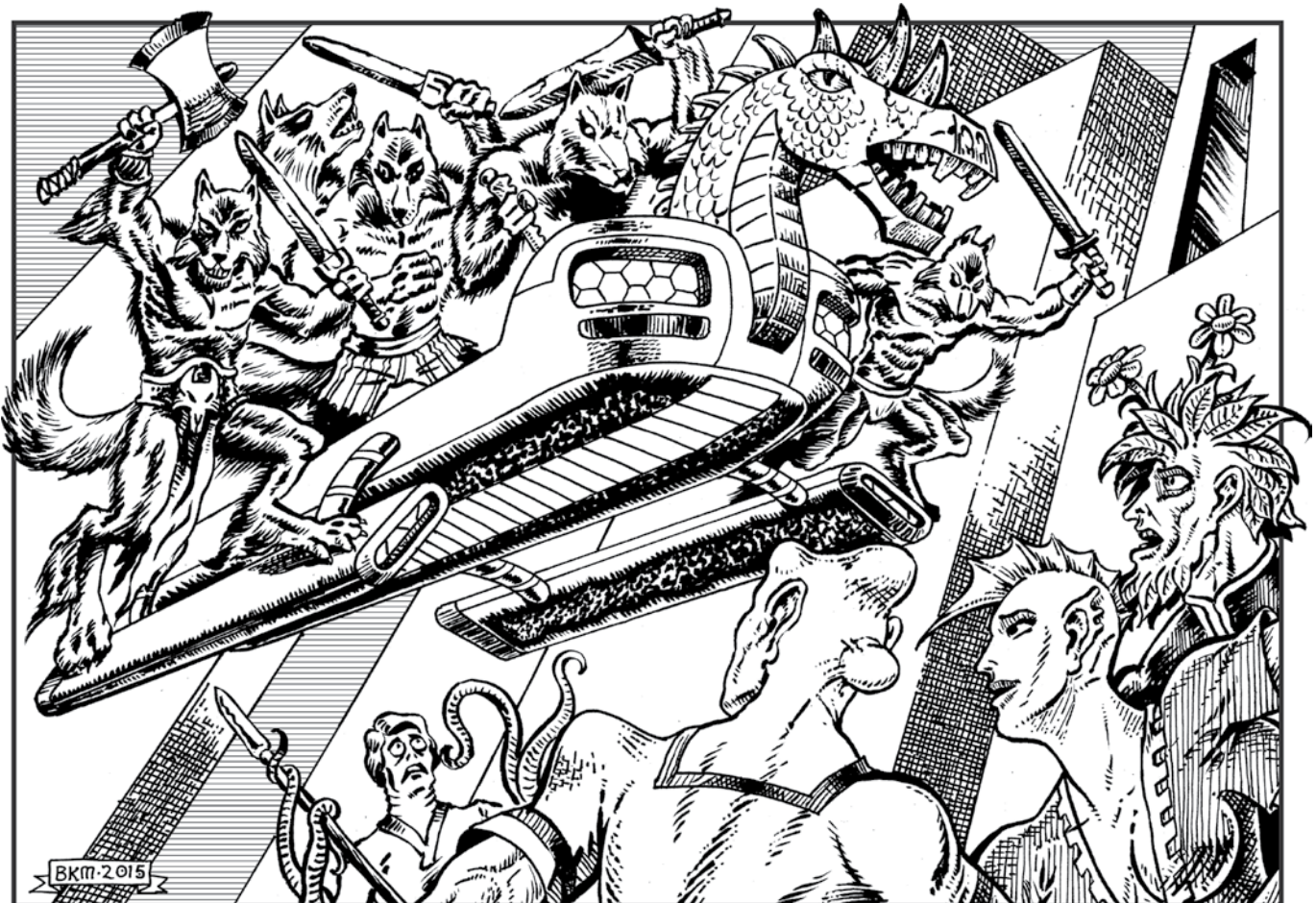

A grappled victim cannot perform physical actions, but may be able to utilize a mental mutation if the referee allows it.

#### **Mutations or Defects:**

**DRAGGING VINES:** The tree can reach targets up to 30' away with its sinuous branches and drag them to an adjacent area. The tree uses this mutation to drag prey into the hot tubs, drowning them in the shallow pools.

**EXPLOSIVE SEED CONES:** The tree can hurl its seed cones up to 50' as an attack. These cones are WC 1 and inflict 1d8+1 damage on a successful hit.

**LIFE DETECTION:** The tree can detect the presence of living creatures within 100' even if they are camouflaged, invisible, or otherwise hidden. It detects the creature's breath and body heat with tiny sensory filaments hidden amongst its needles.

Note that the Relaxation Pools are close to the northernmost buzzer hives. Any creature using a mental mutation against the mutant trees will agitate the buzzers and trigger an attack by the insects, further complicating the battle.

At the bottom of one pool is the rotting body of a wolfoid berserker who was caught unaware by the trees. A gray color band is strapped to its wrist and it still wears its berserker's byrnie.

## **AREA 5-4—WATER PARK:**

**Twisting tubes coil and wind around one another, leading down to a lower tier on the rooftop. A broad stretch of barren earth fills the lower plateau. Several of the 5' wide tubes have become unmoored from their supports and now extend over the side of the roof, ending abruptly in midair.**

The water park no longer works and has long gone dry. The stretch of barren earth is in truth the park's main pool, now filled with dirt and occasionally used by the wolfoids to hold religious rites beneath the artificial sky of Epsilon City. The traces of large bonfires are visible on the bare earth.

The water slide tubes are sometimes used as part of these rites. Criminals and others facing judgment are brought to the top of the slides and forced to choose a random tube. Due to the twisting nature of the water slides, it's difficult to see whether a particular tube ends on solid ground or over the roof's lip. The wolfoids believe that if the creature facing judgment is innocent, he will choose a slide that ends safely over the filled pool below, but guilty parties will fall to their doom when their selected tube ends in midair over the ground 30 yards below.

Any creature choosing to slide down one of the tubes has a 60% chance of it ending over the roof's edge, dropping them to their deaths.

## **APPENDIX: NEW TECH**

### **Berserker's Byrnie**

This object is a waist-length coat of metal rings worn as armor. The metal is lightweight titanium, making it easy to wear without tiring. A small box is attached to the back of the armor situated at the wearer's waist. The armor is AC 3 and the box produces a defensive screen that impedes non-powered kinetic weapons. The screen defends the wearer against 50 points of damage from any unpowered melee or ranged weapon (clubs, spears, swords, arrows, and even pirate blunderbusses), but is useless against energy weapons of all types. Once the 50 point threshold is exceeded, the screen collapsed and cannot be used again until 24 hours has passed. It is powered by a single hydrogen cell that can create eight defensive screens before being exhausted.

### **Fenrir's Mead**

This is a honey wine made from honey collected from the buzzer hives on the roof. The mutant-made honey gives the mead a special property. Anyone consuming a pint or more of the mead is temporarily immune to pain and fights with barbaric ferocity. An imbiber under the effects of the mead adds an additional +1d6 damage die to any successful melee attack. He also gains 20 temporary hit points. These bonus hit points are the first lost if the drinker is injured. Any remaining temporary hit points and the damage bonus vanish one hour after drinking the mead.

# A18 EGYPTIAN COMPLEX

BY JON HOOK

## BACKGROUND

Epsilon City, the very pinnacle of fantastic entertainment, luxury apartment homes, and sleek office parks, was a jewel of civilization set into the center of the starship *Warden*. The city was fully automated and self-sustained by an advanced artificial intelligence (A.I.) that commanded a battalion of robots specially designed to service the city.

Three hundred years ago, the A.I. went insane after a radiation cloud wiped out 99% of the colonists and crew. The starship *Warden* was dying, but throughout the ship the biological and technological survivors fought to maintain their environments and forge a new future for themselves. The Epsilon City A.I. did so too, and reprogrammed its robots to suit the new needs of the city. Packs of wolfoids, along with a few other mutants, have claimed Epsilon City as their new lair; they have adapted to the unique challenges of living within the thematic environments of Epsilon City.

The Egyptian complex is populated by three different tribes of wolfoids and their allied mutants: the Followers of Anubis, the Eyes of Horus, and the Grace of Isis. Each tribe has their own motivations for ruling the complex, and so the tribes are constantly in conflict with each other. Sometimes that conflict is obviously expressed in the form of combat with each other, but many times it is more subtly expressed in the form of sabotage and espionage.

## THE FOLLOWERS OF ANUBIS

This faction's colors are white trimmed in gold. These wolfoids are highly aggressive, and while they welcome new mutant non-wolfoids into the faction, their drive to consume human hands is so great that they outright attack any human that they encounter. Their leader, and current ruler of the entire Egyptian complex, is Pharaoh Khaframeresh; he rules through strength and cruelty. The other factions are bent on killing him.





**TABLE 3-1: EGYPTIAN COMPLEX PERIMETER ENCOUNTER TABLE:**

|           |   |
|-----------|---|
| 01 – 30%  | <p><b>Followers of Anubis Charioteers (4)</b> - AC: 3; HD: 17; hp: 54, 57, 61, 64; RR: 17; CON: 16; MR: 15; STR: 16; DEX: 14; Move: 12; #ATK: 1 by weapon</p> <p>Weapons: Long Bow (WC: 1; Dmg: 1d10 +4) this weapon requires a Strength of 16 or greater to use; Long Spear (WC: 2; Dmg: 10 pts); Claws (WC: 3, Dmg: 1d4+1)</p> <p><b>Mutations:</b> SCALED SKIN: kinetic absorption that reduces physical damage by 5 pts; LIGHT ABSORPTION: heals 6 Hit Points when hit by laser attacks, and is immune to all forms of laser and light attacks.</p> <p><b>Notes:</b> These wolfoids are encountered on a pair of chariots painted white and gold with the hieroglyph of Anubis on the side; a robotic horse pulls each chariot. Each wolfoid has a tall shield and spear, but only one wolfoid per chariot has a bow. While one wolfoid pilots the chariot, the other shoots the bow. This group of wolfoids usually greets strangers aggressively.</p> |
| 31 – 45%  | <p><b>Followers of Anubis Youths (6)</b></p> <p>AC: 4; HD: 12; hp: 39, 40, 42, 43, 49, 51; RR: 14; CON: 13; MR: 12; STR: 13; DEX: 12; Move: 10; #ATK: 1 by weapon</p> <p>Weapons: Dagger (WC: 3, Dmg: 1d4); Claws (WC: 3, Dmg: 1d4+1)</p> <p><b>Mutations:</b> SCALED SKIN: kinetic absorption that reduces physical damage by 3 pts; LIGHT ABSORPTION: heals 3 Hit Points when hit by laser attacks, and is immune to all forms of laser and light attacks.</p> <p><b>Notes:</b> These wolfoids are encountered as a gang on patrol. If half or more of the wolfoids are killed or knocked unconscious, then the rest retreat into the complex. This group of wolfoids is aggressive toward strangers.</p>   |
| 46 – 60%  | <p><b>Eyes of Horus Soldiers (5)</b></p> <p>AC: 2; HD: 16; hp: 47, 50, 52, 52, 56; RR: 15; CON: 15; MR: 15; STR: 15; DEX: 16; Move: 12; #ATK: 1 by weapon</p> <p>Weapons: Long Spear (WC: 2; Dmg: 10 pts); Bronze Sword (WC: 3, Dmg: 1d8+1); Claws (WC: 3, Dmg: 1d4+1)</p> <p><b>Mutations:</b> HEIGHTENED VISION: able to across multiple spectrums of light, and bestows a +1 bonus to hit in melee and missile attacks; HUSK: able to heal 3 pts of damage by shedding the injured skin (limited of 3 pts of damage per single injury).</p> <p><b>Notes:</b> These wolfoids are trained to negotiate with strangers, and to only use combat as a last resort. The wolfoids wear hard plastic torso armor and skirt, and they each carry a tall shield painted white and teal with the Eye of Horus hieroglyph.</p>   |
| 61 – 75%  | <p><b>Eyes of Horus Mounted Patrol (2)</b></p> <p>AC: 2; HD: 16; hp: 49, 55; RR: 15; CON: 15; MR: 15; STR: 15; DEX: 16; Move: 12; #ATK: 1 by weapon</p> <p>Weapons: Bronze Sword (WC: 3, Dmg: 1d8+1); Claws (WC: 3, Dmg: 1d4+1)</p> <p><b>Mutations:</b> HEIGHTENED VISION: able to across multiple spectrums of light, and bestows a +1 bonus to hit in melee and missile attacks; HUSK: able to heal 3 pts of damage by shedding the injured skin (limited of 3 pts of damage per single injury).</p> <p><b>Notes:</b> These wolfoids are trained to negotiate with strangers, and to only use combat as a last resort. The wolfoids wear hard plastic torso armor and skirt, and they each carry a tall shield painted white and teal with the Eye of Horus hieroglyph. Attacking from horseback grants a +2 bonus to the wolfoid's attack roll.</p>   |
| 76 – 90%  | <p><b>Grace of Isis Clerics/Priestesses (4)</b></p> <p>AC: 7 (2); HD: 15; hp: 41, 47, 48, 52; RR: 17; CON: 14; MR: 16; STR: 12; DEX: 14; Move: 14; #ATK: 1 by weapon</p> <p><b>Weapons:</b> Dagger (WC: 3, Dmg: 1d4); Claws (WC: 3, Dmg: 1d3+1)</p> <p><b>Mutations:</b> METALLIC SKIN: able to temporarily transform skin into organic metal (AC: 2) for 10 combat rounds; ILLUSION GENERATION: able to create realistic illusions seen by specific targets within 30m.</p> <p><b>Notes:</b> These wolfoids are welcoming to strangers, and offer asylum to anyone who greets them with equal kindness. The clerics wear headdresses of red and white with the hieroglyph of Isis adorned on it.</p>   |
| 91 – 100% | <p><b>Grace of Isis Infantry (6)</b></p> <p>AC: 6 (1); HD: 16; hp: 40, 48, 49, 51, 54, 58; RR: 13; CON: 15; MR: 10; STR: 17; DEX: 15; Move: 12; #ATK: 1 by weapon</p> <p><b>Weapons:</b> Long Spear (WC: 2; Dmg: 10 pts); Claws (WC: 3, Dmg: 1d4+1)</p> <p><b>Mutations:</b> METALLIC SKIN: able to temporarily transform skin into organic metal (AC: 2) for 10 combat rounds; ILLUSION GENERATION: able to create realistic illusions seen by specific targets within 30m.</p> <p><b>Notes:</b> These wolfoids are cautious, but welcoming to strangers, and offer asylum to anyone who greets them with equal kindness. The clerics carry tall shields painted red and white with the hieroglyph of Isis adorned on it.</p>  |

## THE EYES OF HORUS

---

This faction's colors are white trimmed in teal. These wolfoids are keen tactical warriors skilled in the use of sword and spear. The leader of the Eyes of Horus is Nimhotep, a scholar and vizier; he leads through logic. The Eyes of Horus welcome anyone who wishes to join their faction, but it is customary to collect the hands of humans that have fallen in battle for the faction to dine upon in their honor.

## THE GRACE OF ISIS

---

This faction's colors are red trimmed in white. These wolfoids are the most welcoming and peaceful of all of the packs in the complex. Their leader is Princess Satiah-Kar; she is also the high priestess and spiritual leader of the faction. The wolfoids in this faction have taken a solemn oath to never eat human hands, except for in for certain rituals, when a human is captured and sacrificed, and the hands are eaten by Satiah-Kar alone.

## THE PERIMETER AND GENERAL INFORMATION

When the explorers first view the Egyptian apartment complex, read or paraphrase the following:

**This huge building has sleek and sweeping lines down the full length of the building. The exterior walls for both the ground floor and second floor form an immense hologram marquee. The hologram advertises this immense building as "Thebes of the Hundred Gates;" as the viewer is treated to a sweeping view of the Nile valley and the pyramids of Giza under a blazing sun. Then the hologram shifts and reads as "The Egyptian Community Apartment Complex," as the scene turns to a nighttime shot of the pyramids; the pyramids then begin to glow as they rocket off into the heavens. The building is five stories tall, but each individual floor looks to be 6 meters tall, making the building 30 meters tall, and it's so long that the far end of the building cannot be clearly seen.**

The luxurious apartment buildings in Epsilon City have more in common with a high-end fantasy hotel than they do with traditional apartments. The theme for each apartment complex is fully supported by automated replicators in each room that provides thematic costumes; the restaurants are steeped in ambiance, and thematic artistic installments are distributed throughout the complex. The building is over 90 meters wide and almost 550 meters long; it's five stories tall with 6-meter high ceilings. For the most part, the ground floor and second floor are fully accessible on all sides because of the lack of outer walls. The ground floor and second floor each have thirty Epsilon City taxi docking stations; the third, fourth, and fifth floors have balconies that overlook the city. The holograms on the ground floor and second floor obstruct direct viewing of what is inside those floors, but they do not prevent anyone or anything from passing through the holograms.

All of the public areas in the Egyptian complex are decorated with hieroglyphs and other iconic Egyptian imagery and are tended by maintenance robots on a regular schedule.

Unless otherwise described, all stairwells and hallways are well illuminated with electric wall sconces designed to look like flaming torches. The torches are not designed to be removed from the wall; but, if a resourceful explorer of the *Warden* makes a successful roll on the Item Complexity table versus a Level 7 item, then the electric torch can be removed from the wall with the broadcast power converter inside the torch intact and fully functional. The torch is irreparably damaged with a failed roll on the Complexity Table.

There is a number of turbo lift elevators located throughout the apartment complex. Unless otherwise noted, all lifts require any colored ship systems identification band to be activated. A few of the lifts have been claimed by a specific Egyptian clan; the exterior doors and internal walls for those lifts are decorated with that clan's hieroglyph cartouche. In additions to a colored band, the clan-specific lifts require a spoken password known only to the indicated clan to be activated.

The perimeter of the complex is constantly patrolled by all three Egyptian clans. During the city's daytime cycle, there is a 30% chance that explorers will encounter a patrol, and there is a 60% chance of encountering a patrol during the nighttime cycle. If a patrol is encountered, roll on the following table to determine the make-up of the patrol.

# EGYPTIAN COMPLEX

## Map 1 First Floor

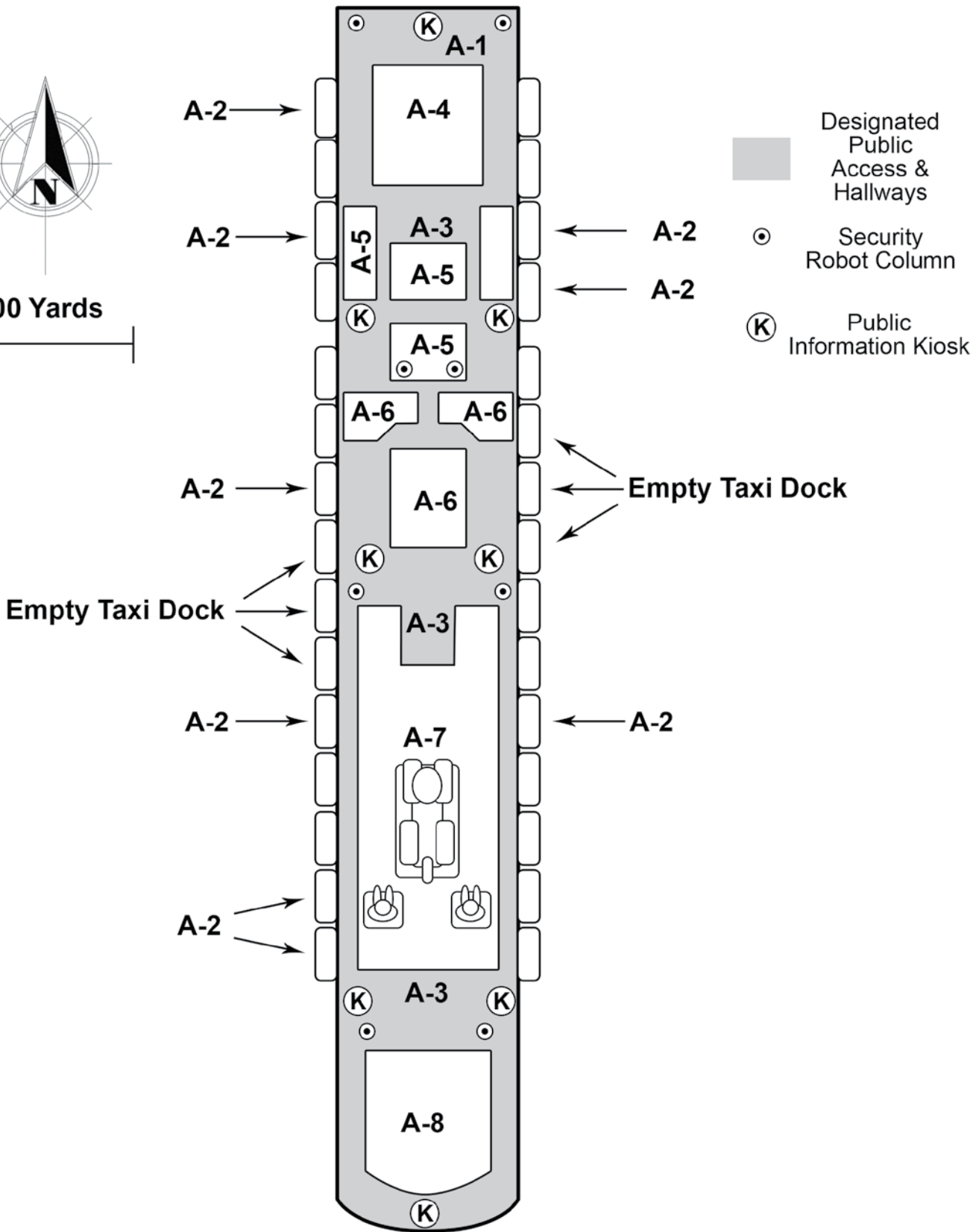

TABLE 3-2: EGYPTIAN COMPLEX INTERIOR ENCOUNTER TABLE:

|           |  |
|-----------|--|
| 01 – 50%  | <p><b>Maintenance Robot (1)</b></p> <p>The maintenance robots within the Egyptian apartment complex are designed to look like large golden lions. The sleek lions have thickly cushioned skid-proof pads on their feet, so the robots move almost silently through the halls. When the robot reaches an area that need attention, several panels slide open on the lion’s body, and four manipulative work tentacles with dexterous fingers are deployed. Maintenance robots respond to anyone wearing any color of ship’s systems band. The maintenance robot (lion model) also has high-powered spotlights in the lion’s eyes, a transmission power receptor antenna in the tail, rechargeable back-up battery cells in the rump, and a light tractor/repulsion beam in the mouth.</p> <p>AC: 3; hp: 80; every 20 pts of damage disables one tentacle; loss of more than half of the robot’s hit points disables the power antennae, spotlights, and tractor/repulsion beam; the robot loses the ability to move when it has less than 10 Hit Points.</p>  |
| 51 – 85%  | <p><b>Security Robots (3)</b></p> <p>The security robots within the Egyptian apartment complex are always grouped in sets of three. Each individual security robot is a 1.5m tall and a half-meter diameter cylinder. The robots are designed to sit on top of each other to form a 3.5m tall column when the robots are stationed in their recharge pad, which is also usually their security station. The metallic robots are covered in beautiful hieroglyphic reliefs around the barrel body of the robot. The artistic hieroglyphs camouflage a dozen sensory eyes and several hidden panels containing security equipment.</p> <p>The security robot’s, (column trio model), primary source of power is a rechargeable battery, and to support that design, the designated station points where the robots are normally stacked into a column positions the column on top of a power recharge disk. The robots then recharge each other in a daisy-chain. Also, each security robot has an anti-gravity system that allows them to fly around. If the security robots observe a transgression, depending on the issue, will usually administer a verbal warning before choosing to deploy and use weapons.</p> <p>Each security robot has four 3m tentacles with a paralysis field tip, two gas pellet ejectors with 100 pellets available for each; the weapons are stored completely within the robot’s body, and are deployed only when in use. The robots respond to commands given by anyone wearing either a red security or navy administration ship systems band.</p> <p>AC: 2; hp: 120; every 30 pts of damage disables one of the robot’s tentacles; every 40 pts of damage disables one of the gas pellet weapons; and the loss of 100 pts of damage disables the anti-gravity system.</p> <p>Note: This random encounter result assumes the explorers have encountered a trio of security robots flying back to their normal security station point.</p> |
| 86 – 100% | <p><b>Medical Robot (1)</b></p> <p>The medical robots within the Egyptian apartment complex are designed to look like a floating Pharaoh’s sarcophagus with a robot torso mounted at the sarcophagus’s feet and a bubbledome head and tentacle arms. The unusual robot has a glowing anti-gravity system under it, allowing it to move wherever it is needed. When the medical robot encounters someone that needs its services, the sarcophagus opens, and the robot torso puts the injured person inside. The injured person is then scanned and treated inside the automated medical unity inside the sarcophagus.</p> <p>The robot torso has four tentacle arms that can lift a quarter-ton of weight; the sensors within the robot’s bubbledome head are used to ascertain the extent of a person’s injuries. The sarcophagus has a wide range of surgical implements and drugs it can use to treat nearly any injury. The medical robot, (sarcophagus model), responds to anyone wearing a white medical or navy administration ship systems band.</p> <p>AC: 4; hp: 300; the loss of 100 pts of damage disables the robot torso; and the loss of 280 pts of damage disables the sarcophagus.</p>  |

The ground floor and second floor have docking stations for Epsilon City taxis, and they are described in more detail in the following floor descriptions. Balconies overlook from the third, fourth, and fifth floors. Many of the balconies look like they are congested with sand, earth, or junk; any accessible balcony is described in detail in the following floor descriptions.

## rites of initiation

---

As described earlier, the wolfoids living in the Egyptian complex are divided into three different factions, the Followers of Anubis, the Eyes of Horus, and the Grace of Isis. The wolfoids are conditioned to think the good of the faction over their own personal needs; a strong faction is one that continues to grow and expand, even if those members are not wolfoid. To this end, each faction has adopted a simple and effective initiation process.

Anyone can join one of the Egyptian complex factions through mock combat. Petitioners can declare their intent to join a specific faction through the Rites of Initiation, or an existing faction member can challenge someone wearing their faction's colors to the Rites of Initiation. The initiation is a simple *mano-a-mano* (or *mano-a-lupo*) non-lethal combat. If the petitioner is the victor, he has earned the right to join the faction; otherwise he has not, and is commanded to leave. If a petitioner earns their way into a faction, he is presented with a silver necklace with a small charm etched with their faction's hieroglyph. All members in good standing with their faction wear their necklace, lest they risk being challenged to another Rite of Initiation. Most wolfoids have two extra faction necklaces on them, just in case.

## MAIN / GROUND FLOOR

Unlike the perimeter of the complex, the wolfoid clans do not patrol the interior of the apartment complex, because they are more focused on the political and military machinations of their clans. Instead, the insane A.I., known to many living within the complex as "Ra," the Egyptian god of the sun, patrols the Egyptian complex interior with maintenance and security robots. Day or night, when moving throughout the interior of the Egyptian complex there is a 20% chance that the explorers may encounter one of Ra's robotic patrols. These patrols occur only in the public access hallways in the apartment complex.

### AREA A-1: ENTERING THE EGYPTIAN COMPLEX

The exterior wall of the Egyptian apartment complex ground floor is a holographic marquee. Sensors read when someone is approaching the hologram, (from either side), and in that area a holographic curtain is "pulled" aside to give that person a clear path to pass through the marquee unobstructed. If the person passing through the hologram is entering the Egyptian complex, a holographic image of one of two greeters is displayed:

- A golden man with a falcon's head wearing only a loincloth as he holds a crook and flail crossed over his bare chest.
- A golden woman with a cat's head wearing only a loincloth as she holds a crook and flail crossed over her bare chest.

The holographic greeter then says, "**I am a servant of Ra. Welcome to Thebes of the Hundred Gates. Please be sure to visit to the Colossi and the Sphinx. If you need any further assistance please ask me; I live to serve.**" The hologram disappears.

Throughout the Egyptian complex are public kiosks that allow visitors to access The Servants of Ra. Unfortunately the memory banks for The Servants of Ra have been severely damaged, and contain minimal information, and all of it pre-dates the disaster that struck the *Warden* three hundred years ago. The Servants of Ra can direct explorers to the nearest restroom, restaurant, the Colossi and Sphinx, the City of the Dead club, The Nile, or the closest taxi dock. Otherwise, the robots respond to questions with "*Unable to comply.*"

Certain areas of the ground floor are designated as public access hallways. These areas are designated due to the decorative tiled floor, designed to look like flagstones. All of the information kiosks, columns of security robots, stairs, costume dispensaries, turbo lifts, and restrooms are located in the public access hallways.

---

## AREA A-2: EPSILON CITY TAXIS

---

There are thirty Epsilon City taxi docking stations located around the ground floor of the Egyptian apartment complex: fifteen on the west side, and fifteen on the east side. Most of the docking stations are empty, but there are nine taxis currently docked. Each taxi is an eight passenger anti-gravity vehicle and has an onboard A.I. that accepts spoken commands from anyone wearing a ship's systems band of any color. The taxis have gull-wing style doors on each side of the vehicle that lift upward and the passengers sit in the center of the vehicle, back-to-back, four on each side. The taxis will transport passengers nearly anywhere within Epsilon City, but the onboard A.I. will avoid any known hazards that may damage the fragile vehicle. AC: 9; hp: 60, the vehicle becomes non-operational after 40 pts of damage; Item Complexity: 8 for an explorer to override the onboard A.I. and fly the vehicle manually.

---

## AREA A-3: TURBO LIFTS & STAIRS

---

This area has a grand stairwell that leads up to the second floor, and flanking the stairs is a pair of turbo lifts on either side. The stairs are designed, like the hallway flooring, to look like flagstones, and the walls of the stairwell are decorated with a hieroglyph pattern that repeats every 3m. There is not a specific message in the hieroglyphs; they are just decorative. Also, a nearby automated clothier dispensary at the foot of the stairs provides visitors with ancient Egyptian garb.

There is a 15% chance that explorers will have a random encounter on the stairs. If there is an encounter, there is a 60% chance that it is a group of wolfoids: roll on the **Egyptian Complex Perimeter Encounter Table**; obviously, these wolfoids are encountered without any vehicles. There is a 40% chance that the encounter is a robot, roll on the **Egyptian Complex Interior Encounter Table**.

The turbo lift cars can only be called by someone using any colored ship systems band. A called car has a 5% chance of having a wolfoid group inside, roll on the **Egyptian Complex Perimeter Encounter Table**;

obviously, these wolfoids are encountered without any vehicles.

The automated clothier dispensary scans the individual who enters the booth and then provides them with a fitted costume of their choosing. Once scanned, the individual can choose to be dressed either as a soldier or a priest. The automated dispensary then asks the individual which faction they want to be associated with, the Followers of Anubis, the Eyes of Horus, or the Grace of Isis. If they select the Followers of Anubis, their garb is white trimmed in gold. If they select the Eyes of Horus, their garb is white trimmed in teal. If they select the Grace of Isis, their garb is red trimmed in white.

Public restrooms are also located in this area.

---

## AREA A-4: CITY OF THE DEAD

---

Depending on when the explorers enter this area, read or paraphrase the appropriate following text:

**Daytime: The walls, floor, and ceiling of this huge room have been painted black. There are many tall tables located along the edges of the room that are bolted to the floor; they each have a half-meter round top and no chairs. There are dozens of colorful fancy light emitters mounted on the ceiling, but none are currently illuminated; instead, the room is lit by hundreds of plain white lights recessed into the ceiling. Scattered throughout the center of this large room are stylized sarcophaguses, and on top of each is what appears to be a dance floor. You also notice several bars located along the perimeter of the room; there is also a dozen golden lion robots moving throughout cleaning the various surfaces in the room.**

**Nighttime: Techno music thumps and thunders from this huge room, crashing against your chest. As you approach, you can see the room is filled with wolfoid youths dancing the night away. A kaleidoscope of flashing lights spin throughout the room from fancy emitters mounted on the ceiling. You catch glimpses through the crowd, that there are stylized sarcophaguses scattered throughout the room that some of the wolfoids are dancing upon. You can see tall tables along the perimeter of the room, each with a few wolfoid youths clustered around having drinks and merriment. And beyond the tables are several well-stocked bars.**



This room is a gaudily decorated Egyptian-themed dance club. The club is fully automated, so that during the daytime cycle, the club is well lit and serviced by a dozen lion model maintenance robots. During the nighttime cycle, the club is lit by colorful neon lights as techno music blasts through the room; robots are typically not in the club during the night. The bar has a wide range of alcoholic beverages available, but no food.

The wolfoid youths of the various clans have an unspoken truce in this room. The City of the Dead is a place where they can come to mingle and relax. The truce extends even to those strangers who would visit the club. But, if visitors begin to stir up trouble, the wolfoids are quick to leap into action. Each bar has a small safe, and locked within one of them is a gold programmer's ship system band that was locked away before the great disaster. The wolfoids do not know the combination, but the safe is a Complexity Level 6 item; with a successful roll, the electronic lock can be overridden. Otherwise, the safe door can be broken off after it takes 350 points of damage.

## AREA A-5: THE GARAGE

---

Read or paraphrase the following when explorers enter this area:

**Clearly, this is where the Egyptian-styled vehicles, the chariots, are stored when not in use. Several chariots are parked in the north end of the garage in numbered spaces, and the onboard gyros help balance the two-wheeled carriages so they can stay upright. The south end of the garage is where the recreational robotic horses are recharged.**

The sleek chrome robotic horses gleam as the lights reflect off their bodies. The horse robots have thickly cushioned skid-proof pads on the bottom of their hooves, and imbedded sound effects project the clip-clop sound of their hooves striking the ground when they are moving. Magnetic couplers on the horse's hips allow the chariots to connect to the horse. Once connected, the charioteer can control the horse from the control panel in the chariot. The horse robots respond to anyone with any colored ship systems band.

## AREA A-6: THE MAJESTIC LUXOR

**Horse Robot** – AC: 4; hp: 100; the horse becomes immobile after losing at least half of its hit points.

In one corner of the south garage lot are three deactivated robotic horses clustered together on the ground, half piled upon one another. Much of the chrome has been chipped off of the horses, exposing rusted metal below. That area of the garage is dark because of damaged lights that maintenance robots have not replaced or repaired. Due to the darkness, it is difficult to see a large patch of Dark Fungus on the deactivated horses and the floor. The fungus blends in perfectly with the shadows, and cannot be seen beyond 3m; anyone closer than 3m notices the fungus with a roll of 1 – 2 on a d6 at 3m, a roll of 1 – 3 at 2m, or a roll of 1 – 4 at 1m, (it is suggested that the Starship Master make this roll in secret as the explorers approach the pile of damaged horse robots.) The patch of fungus weighs approximately ten kilograms, so it is a fairly large patch.

**Dark Fungus (mutant plant)** – DEX: n/a; MR: 16/3; RR: 5; CON: 6; STR: n/a; Move: negligible; AC: 8; HD: 20; hp: 59; #ATK: 1 mental mutation; Mutations: ILLUSION GENERATION, TELEPATHY, FORCE FIELD GENERATION; SP: the fungus has an effective Mental Strength of 16 offensively, but a Mental Resistance of 3 defensively. The fungus tries to trick people into touching the fungus, because it does 10 pts of damage on contact. The fungus increases its weight in kilograms by half of the slain victim's Strength value.

Read or paraphrase the following when explorers enter this area:

**As you enter this area, you discover a lavish restaurant. As you cross the threshold, a holographic image of a Servant of Ra appears before you, "Welcome to The Majestic Luxor. How many in your party?" The restaurant is empty of customers; there are no wolfoids present, and due to the layers of dust, it doesn't look like anyone's been here in quite some time. You see that the restaurant has a pair of kitchens on the north end of the restaurant's area, and the dining area fills the south end. In the center of the dining area is a large black glass pyramid. The glass faces begin to flicker to life as images of sweeping desert vistas and the grand imagery of a Pharaoh being worshiped by the masses.**

The restaurant has clearly not been in use for decades. The kitchens are fully automated, but the wolfoids learned long ago that anything that comes out of these kitchens is highly toxic. If the explorers do sit down for dinner, the table presents a menu of exotic Middle Eastern cuisine. But, if they place an order, the meal that comes out from the kitchen has strength 16 poison. The poison, if it is ingested and overcomes the explorer's constitution, paralyzes the victim leaving them in intense abdominal pain and unable to move. The meal looks and smells appetizing, but the spices were radiated long ago, and are forever tainted.





The restaurant has atmospheric lighting, so the pyramid is the brightest source of light in the dining room. Deep shadows are everywhere, making it difficult to see anything in the dining room. In one of the two kitchens is a nest of Black Ones, large mutant spiders. If anyone enters the kitchen, they discover one corner of the kitchen to be funnel web nest where four Black Ones live. If the automated kitchen comes to life to prepare a meal, then the spiders venture out to discover who has invaded their territory.

**Black Ones (mutant spiders) (4)** – DEX: 17; MR: 4; RR: 8; CON: 10; STR: 14; Move: 15; AC: 8; HD: 14; hp: 41, 45, 47, 50; #ATK: 1 (bite: WC: 3, Dmg: 1d6+1 with poison; or mutation); Mutations: ELECTRICAL GENERATION; SP: poison strength 11 with bite attack; the poison causes pain and nerve damage as 1d10 pts of damage. The electrical attack can shoot a bolt of energy up to 4m distance, WC: 6, Dmg: 4d6; this mutation is only usable once every three combat rounds. The spider's abdomen has a blue glow when fully charged and ready to shoot. The spider can hold the charge for up to an hour.

In a corner of the Black Ones web nest are two corpse husks of humans that have been exsanguinated. Besides other non-descriptive gear, the male corpse is wearing a pair of battle gloves, (the hydrogen cells are half-empty), and has an electric bolo lying next to him, (the hydrogen cells are completely empty). A paralysis rod, (the hydrogen cell half-empty), lies next to the female corpse.

## AREA A-7: THE COLOSSI AND THE SPHINX

Read or paraphrase the following when explorers enter this area:

**This room is huge! A clean and narrow public walkway circumvents the room, but the vast majority of the room is filled with sand. The high ceiling, extra bright lights, and artificial winds enhance the sensory details, making this room a perfect replica of a desert landscape. The winds in this room have created dunes two and 3m high, but through the dunes you can see the immense forms of the twin Colossi and the mysterious Sphinx.**

Though it is difficult to notice through casual observation, the center sand-filled space of this huge room is 2 meters deep, when compared to the public walkway along the perimeter of the room. The room was first filled with sand, and then the Colossi and Sphinx were erected. The artificial winds are controlled by Ra, the insane apartment complex A.I., and it occasionally shifts the winds to keep the sand levels distributed as evenly as possible.

The Colossi are a pair of huge stone statues in a seated position facing north; each statue is 7 meters tall. The western statue is of the god Ra, and the eastern statue is of the god Set. The statues are made of solid granite. The statues are very sturdy; more than 500 pts of damage would need to be inflicted on the statue's base in order to topple it over.

The Sphinx was originally designed to be an interactive museum attraction, but those days are long behind it. The Sphinx sits on top of a 2 meter high base, and the Sphinx itself is 4 meters high; the entire Sphinx structure is 12 meters long and 5 meters wide. There is an obvious door, half ajar, on the north-facing wall of the base that the Sphinx sits upon.



Hidden somewhere in the desert just north of The Sphinx is the lair of an immature horned viper. The first sign that explorers have stumbled across the lair are a few partial wolfoid skeletons half-buried in the sand. When the skeletons are discovered, the horned viper that was hidden in the nearby sand rears up to attack the explorers.

**Immature Horned Viper (mutant snake) (1)** – DEX: 18; MR: 5; RR: 18; CON: 18; STR: 12; Move: 6; AC: 4; HD: 13; hp: 45; #ATK: 2 bites or 1 constrict (bite: WC: 4, Dmg: 2d6 + poison 15; constrict: WC: 2, Dmg 10 pts/rnd); Mutations: TALLER, CHAMELEON POWERS, HEIGHTENED SMELL, HEIGHTENED SPEED, HEIGHTENED HEARING; SP: the necrotic poison does 25 pts of damage per bite. The horned viper always attacks the largest prey; striking twice with the bite and then retreating to see if the poison kills the prey. The viper can easily track prey with its heightened sense of smell. If the poison fails to kill the prey, the viper attempts to constrict the prey to crush it to death. The hard plates that run the length of the viper can be used as a small shield, or assembled into AC 5 armor.

The snake's lair is well disguised by the sand; a roll of 1 – 2 on a d6 is required to find the lair. Hidden inside the lair is the skeleton of a human man dressed in ancient Egyptian clothing; a protein disruptor pistol happens to be under the skeleton's costume.

---

### AREA S-1: THE GREAT NILE

---

Read or paraphrase the following when the explorers enter this room:

**Sand from the desert outside trails into the long corridor that leads to this room. The corridor was a cramped 2 meters tall, but the room opens up to a more comfortable 2 ½ meters tall. A long table in the center of the room displays a diorama of the Nile River. Around the perimeter of the room are little piles of sand and a variety of stations that highlight different facts about the river.**

Note: Due to the Brain Stink mutation possessed by the Iron Guardian mutant scarabs hiding in this room, mutants with any form of offensive mental mutation must roll on the Mental Strength Chart to see if they are able to enter.

A variety of facts and historical information is avail-

able about the Nile River in this room; including that it was one of the longest rivers on ancient Earth, that it flowed from the south to the north, and that it had two major tributaries, the White Nile and the Blue Nile. All of the stations present the data on printed plaques for the nostalgia effect of a museum.

Nested in the piles of sand is a colony of scarab beetles. The beetles are content to be left alone, but if anyone disturbs any of the piles of sand, then the beetles scurry to defend themselves and their home. The beetles won't pursue anyone out of this room, nor will they be driven from this room.

**Iron Guardians (mutant scarabs) (27)** – DEX: 15; MR: 10; RR: 5; CON: 3; STR: 3; Move: 20; AC: 2; HD: 1; hp: 1, 1, 1, 1, 1, 1, 1, 1, 2, 2, 2, 2, 2, 3, 3, 4, 4, 4, 4, 5, 5, 5, 6, 6, 6, 6, 6; #ATK: 1 (bite: WC: 3, Dmg: 1 per beetle; or mutation); Mutations: *brain stink*, *metallic skin*, *mass mind*; SP: the beetle's carapace is always a blue metal.

---

### AREA S-2: THE GIZA NECROPOLIS

---

Read or paraphrase the following when the explorers enter this room:

**Like the entrance corridor, the corridor leading to this room is a cramped 2 meters tall, and again this room opens up to a more comfortable 2 ½ meters tall. In the center of this room is a large table with a diorama of the six Pyramids of Giza upon it, and around the perimeter of the room is a number of stations with historical information about the history of these ancient Earthly wonders. A flight of stairs at the back of the room leads up to a second floor. Other than a light layer of dust, this room is clean of debris.**

This museum room contains lots of historical data about the Egyptian pyramids, and like the Great Nile museum room, the data is displayed on nostalgic plaques.

---

### AREA S-3: LAIR OF THE STONEBORES

---

Unless the explorers are specifically looking to discover any hidden or concealed doors or hatches, the false door in the corridor between Area S-1 and Area S-2 is discovered on a roll of 1 on a d6. If the explorers are looking for hidden doors, then the false door is discovered on a roll of 1 – 4 on a d6. The false door is a

# SPHINX

## Level 1

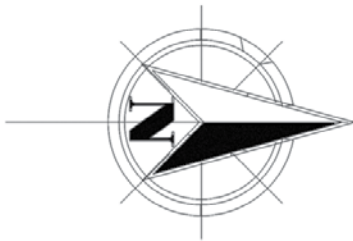
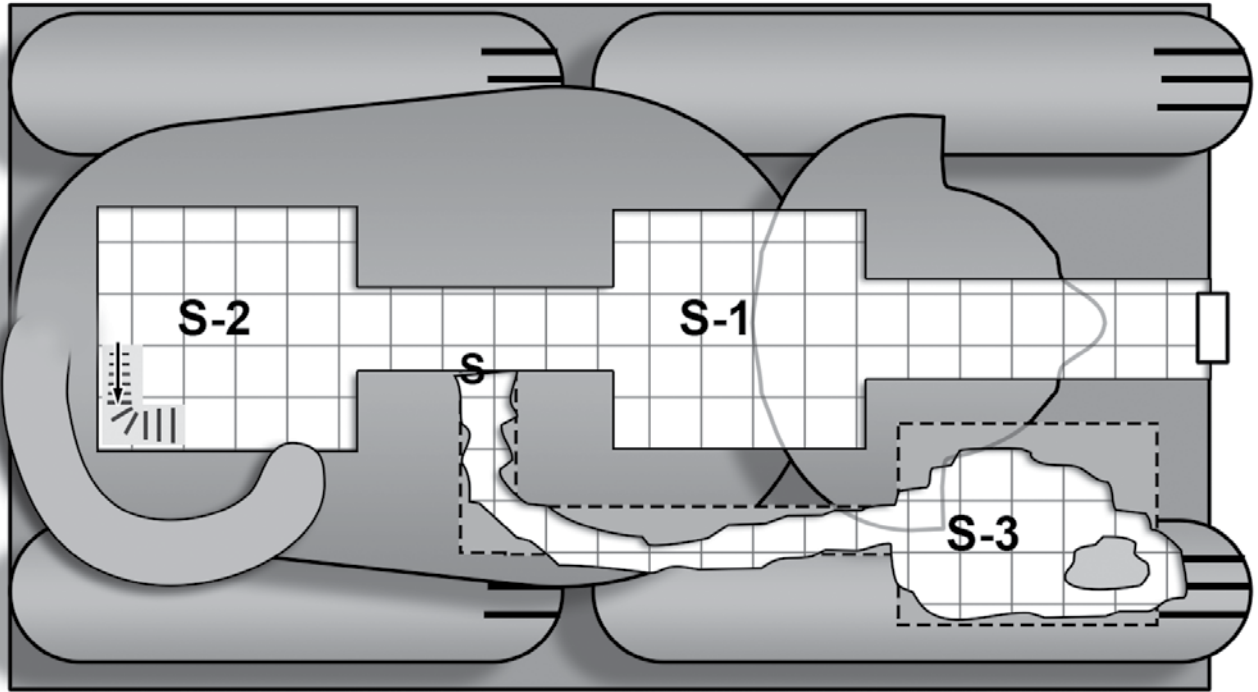

□ = 10 feet

## Level 2

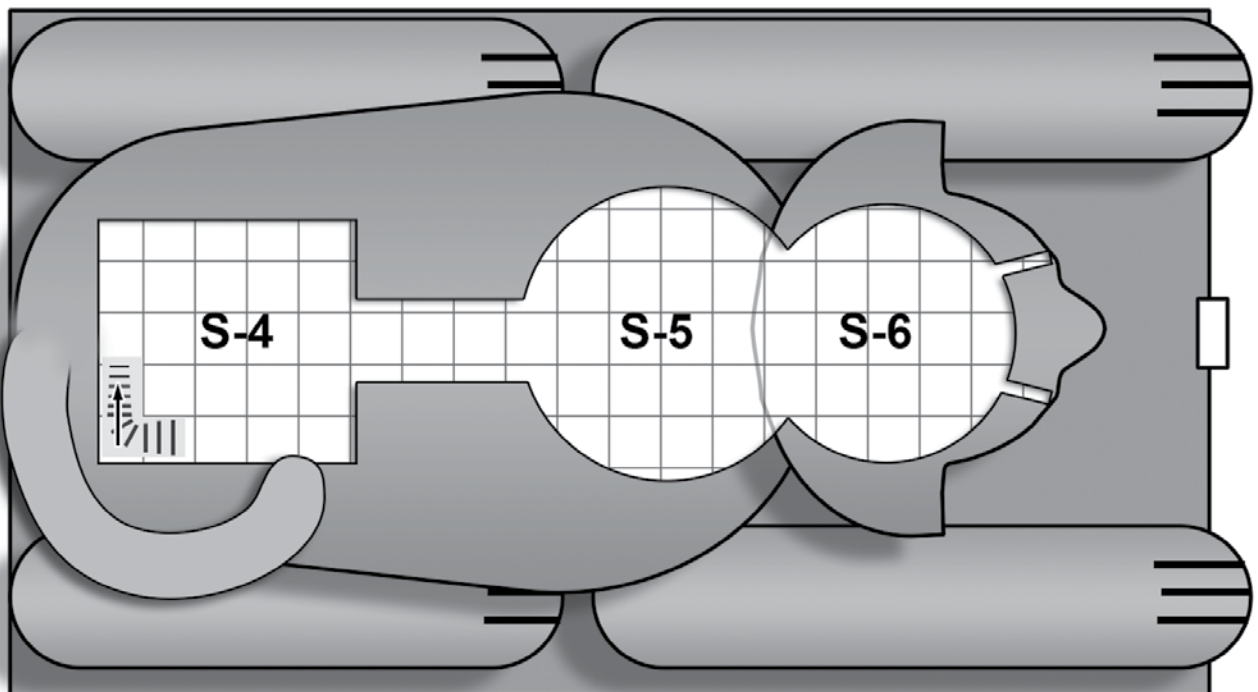

loose “stone” block that can be moved out of the way. The faux stone is actually made of plastic, but the rest of this building is actual stone. Once the plastic block is removed, a rough tunnel dug through solid stone is exposed. The tunnel is extremely tight, and standard 2m tall explorers would be required to crawl through this tunnel. Explorers over 2m in height cannot enter this tunnel.

Read or paraphrase the following when the explorers crawl through the tunnel and enter this room:

**The tunnel opens up into a den, with a ceiling is roughly 1 ½ meters tall and a varying width. Like the tunnel, most of the floor in this room is rough gravel, but a “pool” of desert sand is in the far corner of the room. A pair of strange creatures snarls at you from the far end of the room; a nest of squalling pups being protected by plump and furry parents.**

A mated pair of stonebores have made their home inside the very stone blocks of the Sphinx. The creatures are quite adapted at tunneling through solid stone, and they thrive in the artificial desert habitat inside the Egyptian complex. The creatures will defend their home, but will quickly flee if the battle is not going well for them. There are five defenseless pups in the nest, and if the creatures flee each adult is able to carry two pups in their mouth, leaving one pup to the mercy of the intruders. The pool of sand provides an avenue of escape from the den that they can tunnel through effortlessly under the Sphinx to the desert beyond.

**Stonebore (mutant beavers) (2)** – DEX: 11; MR: 12; RR: 10; CON: 12; STR: 8; Move: 10; AC: 7; HD: 25; hp: 77, 91; #ATK: 1 (bite: WC: 3, Dmg: 1d8+1; or mutation); Mutations: HEIGHTENED INTEL-LIGENCE, HEIGHTENED VISION, QUILLS, HEAT BREATH; SP: the stiff quills on the creature’s body provides a layer of protective armor. If anyone attempts to touch the stonebore, the creature can flex the quills, (WC: 3, Dmg: 1d4), in defense. The stonebore cannot shoot its quills. The creature’s heat breath can be shot up to 2m distant, (WC: 5, Dmg: 4d6).

The stonebores are intelligent enough to understand verbal communication, even though they themselves do not possess the power of speech. Human explorers with a Leadership Potential of 12 or higher have a chance to earn the stonebores’ trust.

LP 12 – 14 = 10%

LP 15 – 17 = 15%

LP 18 = 20%

If an explorer successfully earns the stonebores’ trust, the creatures chitter with each other as they confer on what to do next. Finally, the female stonebore digs into the pool of sand for a few seconds, and then emerges with a brass dog whistle; she then presents the whistle to the explorer that earned their trust.

## AREA S-4: THE KING’S CHAMBER

Read or paraphrase the following when the explorers enter this room:

**The stairs lead up to a room similar in size to the one below. In the center of the room is a large sarcophagus. This stone sarcophagus is open; the decorative lid is propped up against the wall. Inside the sarcophagus is a human figure tightly wrapped in white bandages; the mummy wears a golden mask designed like a Pharaoh’s headdress and it holds a crook and flail crossed over its chest. Around the perimeter of the room are some museum stations that describe the history of ancient Egyptian burial practices.**

The mummy in the sarcophagus is an entertainment robot designed to sit up when someone approaches the sarcophagus and give a speech about the process of mummification, and how ancient Egyptians believed the ritual prepared the Pharaoh for the afterlife.

The golden mask that the mummy wears is a decorative prop; it is not made of actual precious metals. The insane Egyptian complex A.I., Ra, is possessive and protective of the Sphinx Museum; if Ra senses that the explorers are looting or defacing the museum in any way, then Ra will possess the mummy to be its instrument against the explorers. If the wrath of Ra is not provoked, the mummy is programmed to lie back down into the sarcophagus when visitors exit the room.

**Entertainment Robot (mummy) (1)** – This general purpose humanoid robot is covered in synthetic bandages. AC: 3; hp: 90; a targeted limb, (arm or leg), is disabled after 15 pts of damage to the limb. The robot contains a tractor/repulsion beam in each hand, and active sensory gear that allows it to “see” without camera lenses. The main weapons for the mummy are its powerful fists, (WC: 3, Dmg 1d8+1). Tactically, the robot attempts to pull its target close to it with a tractor beam, and then bludgeon it with its other hand.

## AREA S-5: HALL OF THE GODS

Read or paraphrase the following when the explorers enter this room:

**The perimeter of this circular room is lined with golden robotic statues, each a representation of a different Egyptian god. Each entertainment robot stands perfectly still; with just their heads turning and their eyes tracking along with you as you enter.**

The entertainment robots in this room are several generations older than the mummy robot, and are not equipped to engage in combat. If the explorers approach one of the gods, that robot begins to describe the god that it depicts. The gods depicted in this room are Ra, Osiris, Set, Horus, Sobek, Thoth, Anubis, and Isis. The robots are capable of projecting small holograms from their hands that they use as a visual guide when the robot is giving the informative speech about the god that it depicts.

- **Ra** – The supreme Egyptian god, ruler of all of creation; the God of the Sun. Ra is depicted as a man with a hawk’s head; he also has the sun-disk resting on his head.
  - **Osiris** – The god of the afterlife, the underworld, and the dead. Osiris is depicted as a man with black and green skin. Brother to Set, husband to Isis, and father to Horus.
  - **Set** – The god of the desert, of storms, chaos, and war. Set is depicted as a man with a fictitious animal head; the head has a long curved snout and tall rectangular ears. Brother to Osiris, and the rival to Horus.
  - **Horus** – The god of the sky, the hunt, and kingship. Horus is depicted as a man with a falcon’s head. Son of Osiris and Isis, and the rival to Set.
  - **Sobek** – The god of the Nile, fertility, and military prowess. Sobek is depicted as a man with a crocodile’s head.
- Thoth** – The god of knowledge, magic, and the judgement of gods and the dead. Thoth is depicted as a man with an ibis’ head. Husband to Ma’at.
- **Anubis** – The protector of the dead; the god of mummification and the afterlife. Anubis is depicted as a man with a dog’s head. Father to Kebechet.

- **Isis** – The goddess of health, marriage, and wisdom. Isis is depicted as a woman wearing a throne-shaped headdress as she holds an Ankh. Wife to Osiris and mother to Horus.

## AREA S-6: HEAD OF THE SPHINX

Read or paraphrase the following when the explorers enter this room:

**In the center of this circular room is a table with a diorama of The Sphinx upon it. The perimeter of the room has a few stations with historical information about the ancient Sphinx back on Earth.**

One of the stations in this room displays a chunk of stone sealed into a protective glass box. The stone is a chunk from the actual Sphinx back on Earth. Another station presents the Riddle of the Sphinx. When this station is approached, a tiny hologram of the Sphinx as a living creature is displayed above the station; The Sphinx then asks the visitor a riddle.

| D6 | RIDDLE  | ANSWER                       |
|----|---|------------------------------|
| 1  | What is that which in the morning goeth upon four feet; upon two feet in the afternoon, and in the evening upon three?  | Man                          |
| 2  | There are two sisters: one gives birth to the other, and she in turn gives birth to the first. Who are the two sisters?   | Day and Night                |
| 3  | What is as big as an elephant, but lighter than a feather?  | Wind                         |
| 4  | I make memories that last a lifetime. Without me you’ll be miserable. If you miss me, you can gorge and it’s okay. What am I?   | Sleep                        |
| 5  | Always old, sometimes new. Never sad, sometimes blue. Never empty, sometimes full. Never pushes, always pulls. What am I?   | Moon                         |
| 6  | Most of you have two eyes; I have only one. Most of you have eyeballs; I have none. Most of you have eyes that are not dangerous, and neither do I, but all together I am extremely dangerous. What am I? | Storm, Tornado, or Hurricane |

# EGYPTIAN COMPLEX

## Map 2 Second Floor

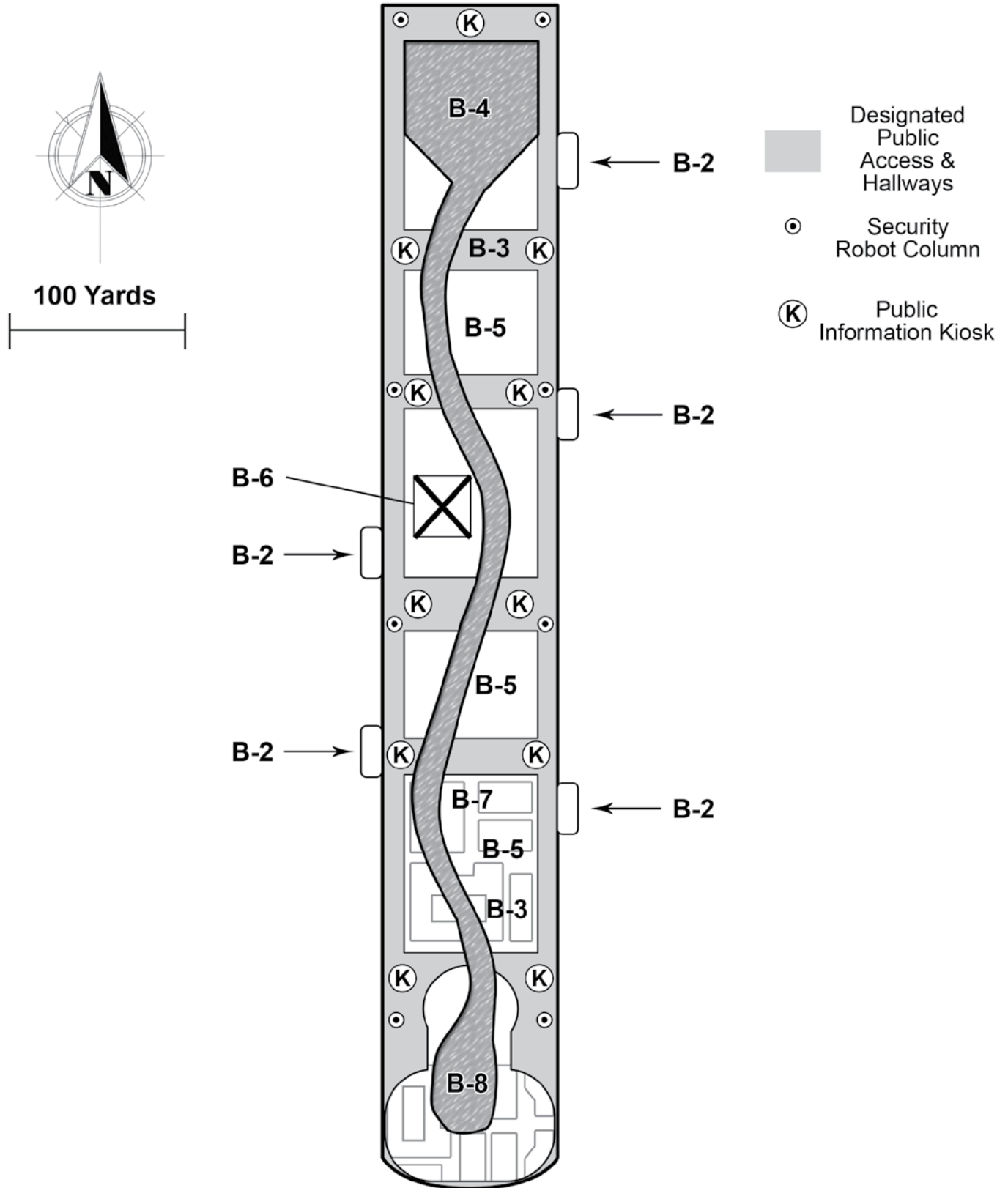

Unbeknownst to the participant engaged with the holographic Sphinx, they are playing a game with The Sphinx. With each correct answer, a holographic green dot is displayed under the holographic Sphinx. If the same visitor is able to answer all six riddles in a single uninterrupted session, then the Sphinx says, "Achievement unlocked," and a small panel on the wall opens and a prize of a single sky-blue sciences ship systems band is displayed. The holographic Sphinx only has one band prize available to be given away, so any future achievements of the riddles results in the presentation of an empty space in the wall. The Sphinx uses both facial recognition and voice print identification to uniquely identify each participant who attempts to answer the riddles. If a participant has ever failed to answer a riddle correctly, that participant cannot ever win the Sphinx's prize.

There are two circular windows in this room. The windows are the pupils in the eyes of The Sphinx museum. Looking out the window, the viewer is treated to the desert vista outside.

---

## AREA A-8: CLEOPATRA'S CAFETERIA

---

Read or paraphrase the following when explorers enter this area:

**This area is brightly lit in a kaleidoscope of neon colors. A flashing holographic sign announces this as Cleopatra's Cafeteria. The perimeter of the area is defined by a dozen themed and automated food dispensers. A gang of 3m tall wolfoids dressed in armor of white and gold are dining here. As you enter, they all stand to confront you.**

The wolfoids dining here are members of the Followers of Anubis faction. Their reaction to the explorers depends on how the explorers are dressed. If the explorers have utilized an automated clothier dispensary to dress themselves in costumes colored in the Followers of Anubis faction colors, then the wolfoids greet them cautiously. Unless the explorers have been initiated into the faction already, the wolfoids challenge each explorer to individual to personal combat, as per the Rites of Initiation. Otherwise, if the explorers are wearing any other faction's colors, or if they are not dressed in ancient Egyptian garb at all, the wolfoids leap to attack the explorers.

**Followers of Anubis Wolfoids (8)** – AC: 3; HD: 16; hp: 46, 54, 54, 56, 59, 62, 64, 64; RR: 17; CON: 16; MR: 15; STR: 16; DEX: 14; Move: 12; #ATK: 1 by

weapon. Weapons: Short Sword (WC: 3; Dmg: 1d6); Claws (WC: 3, Dmg: 1d4+1). Mutations: SCALED SKIN: kinetic absorption that reduces physical damage by 5 pts; LIGHT ABSORPTION: heals 6 Hit Points when hit by laser attacks, and is immune to all forms of laser and light attacks.

## SECOND FLOOR

Like the ground floor, the second floor of the Egyptian apartment complex was designed to entertain the residents. The outstanding feature on this floor is The Nile that flows from the south end of the complex to the north end. Also like the ground floor, the public hallways are patrolled by Ra's robots. There is a 20% chance that explorers may face a robotic encounter; the Starship Master rolls on the **Egyptian Complex Interior Encounter Table** to determine the nature of the encounter.

---

### THE NILE

---

The majestic river Nile runs the full length of the second level; starting from a pool known as The Source, and ending in a much larger pool known as The Mediterranean. The entire river is configured to perpetually flow from south to north, and then it's cycled through conduits in the floors back to The Source again. Along the length of the river, a series of jets create a current that keeps the river moving steadily.

The river is 2m deep in the center, and only half a meter along the edges. There are several public access bridges over the river, and it is possible to swim across the river as long as the swimmer isn't panicking or under duress. If the Starship Master determines that a swimmer is under duress, then re-task the Mental Strength Chart to test the swimmer's strength. Exchange the swimmer's Strength value for the Mental Resistance value on the left side of the chart, and consider The Nile to have Strength 12 along the top of the chart. The swimmer then rolls 1d20; a success is a roll equal to or less than the number indicated on the chart, a failure is a roll over the number. A success results in the swimmer successfully navigating the river, but a failure results in 2d6 drowning damage. A swimmer must continue to make swim rolls as long as they are under duress in the water.

The river supports a thriving ecosystem of algae, insects, and fish. Unless otherwise noted, none of these pose any significant threat to sentient species.

## AREA B-1: ENTERING THE EGYPTIAN COMPLEX

The exterior wall of the Egyptian apartment complex second floor is a holographic marquee. Sensors read when someone is approaching the hologram, (from either side), and in that area a holographic curtain is “pulled” aside to give that person a clear path to pass through the marquee unobstructed. If the person passing through the hologram is entering the Egyptian complex, a holographic image of one of two greeters is displayed:

- A golden man with a falcon’s head wearing only a loincloth as he holds a crook and flail crossed over his bare chest.
- A golden woman with a cat’s head wearing only a loincloth as she holds a crook and flail crossed over her bare chest.

The holographic greeter then says, *“I am a servant of Ra. Welcome to Thebes of the Hundred Gates. Please be sure to visit to the Colossi and the Sphinx. If you need any further assistance please ask me; I live to serve.”* The hologram this disappears.

Throughout the Egyptian complex are public kiosks that allow visitors to access The Servants of Ra. But the memory banks for the Servants of Ra have been severely damaged, containing minimal information, and all of it pre-dates the disaster that struck the Warden three hundred years ago. The Servants of Ra can direct explorers to the nearest restroom, restaurant, the Colossi and Sphinx, the City of the Dead club, The Nile, or the closest taxi dock. Otherwise, the robots respond to questions with *“Unable to comply.”*

Certain areas of the second floor are designated as public access hallways. These areas are designated due to the decorative tiled floor designed to look like flagstones. All of the information kiosks, columns of security robots, stairs, costume dispensaries, turbo lifts, and restrooms are located in the public access hallways.

## AREA B-2: EPSILON CITY TAXIS

There are thirty Epsilon City taxi docking stations located around the second floor of the Egyptian apartment complex, (fifteen on the west side, and fifteen on the east side). Most of the docking stations are empty, but there are five taxis currently docked. Each taxi is an eight passenger anti-gravity vehicle and has an on-

board A.I. that accepts spoken commands from anyone wearing a ships system band of any color. The taxis have gull-wing style doors on either side of the vehicle that lift upward and the passengers sit in the center of the vehicle, back-to-back, four on each side. The taxis will transport passengers nearly anywhere within Epsilon City, but the onboard A.I. will avoid any known hazards that may damage the fragile vehicle. AC: 9; hp: 60, the vehicle becomes non-operational after 40 pts of damage; Item Complexity: 8 for an explorer to override the onboard A.I. and fly the vehicle manually.

## AREA B-3: TURBO LIFTS & STAIRS

Same description as Area A-3: Turbo Lifts & Stairs above.

## AREA B-4: THE MEDITERRANEAN

Read or paraphrase the following when explorers enter this area:

**Before you is a lake; a holographic sign blinking over the lake declares it as “The Mediterranean.” A public flagstone walkway leads around the lake; otherwise the ground is covered in scrub grass and sand.**

A congregation of hissers lives in this area. The congregation is dominated by an immense and ancient albino hisser the wolfoids have dubbed Sobek. This creature survived the apocalypse that devastated The Warden and was mutated into the monster that it is today. Unless they are provoked or hungry, the hissers are usually docile.

**Average Hisser (3 to 7)** – DEX: 8; MR: 4; RR: 13; CON: 12; STR: 16; Move: 10; AC: 4; HD: 12; hp: 36, 37, 39, 43, 47, 51, 54; #ATK: 1 tentacles; Mutations: PARALYSIS TENTACLES, RADIATION RESISTANT FLESH; SP: the hisser strikes with its tentacles to stun their prey prior to consumption, (mental attack with Mental Strength 12).

**Sobek (ancient albino hisser) (1)** – DEX: 6; MR: 5; RR: 16; CON: 15; STR: 22; Move: 7; AC: 2; HD: 25; hp: 82; #ATK: 2 tentacles; Mutations: TALLER, PARALYSIS TENTACLES, RADIATION RESISTANT FLESH, HEIGHTENED STRENGTH; SP: Sobek attacks with his tentacles to stun his prey before consumption, (mental attack with Mental Strength 14).



## AREA B-5: THE GARDENS

Read or paraphrase the following when explorers enter this area:

**Before you, you see fields of green irrigated by The Nile. You see a variety of crops being tended; including wheat, figs, and pomegranates. Figures in ancient Egyptian garb are working in the fields.**

The primary food source for the Egyptian complex is grown in the fields that run along The Nile. As the explorers approach a field, the Starship Master can roll to determine which faction is tending the crops.

**TABLE 3-3: GARDEN ENCOUNTERS**

| D6    | FACTION             | FIELD HANDS  |
|-------|---------------------|--|
| 1 – 2 | Followers of Anubis | 2 – 8 Older mutants: over the age of 40 cycles                 |
| 3 – 4 | Eyes of Horus       | 3 – 10 Mutant teens: between the age of 12 and 20 cycles       |
| 5 – 6 | Grace of Isis       | 2 – 12 Mutant zealots: devout believers in Princess Satiah-Kar |

**Average Mutant (8 – 12)** – DEX: 14; MR: 12; RR: 11; CON: 14; STR: 13; Move: 10; AC: 7; HD: 14; hp: 37, 38, 44, 47, 47, 50, 51, 51, 52, 53, 54, 54; #ATK: 1 mutation or club (field tool); Mutations: *1 random physical, 1 random mental*; SP: the field hand mutants retreat if at least one of their number is mortally wounded.

All of the mutants have one random physical and one random mental mutation. There are no true humans or mutant animals working in the fields. The wolfoid-run Egyptian factions delegate their mutant members to toil the fields. In addition to the crops, the mutant field hands tend to the general livestock that lives in the fields; the creature is known as a mox. The mox is a two-headed hermaphroditic animal that is half bull ox and half cow. The animal can breed with itself, pull plows, produce milk, and can be slaughtered for meat, when necessary.

The mutants have a lot of work to do, and are predisposed to ignore anyone who enters into the fields. They only intervene with the explorers if they disrupt their work. The mutant's loyalty to their faction cannot be swayed, but they can be interviewed by the explorers for information.

If the field hands are approached peacefully, it is possible to interview them. A group of field hands only provide two rumors before they insist that they must return to work. If the explorers press them for more information, then the field hands become prone to aggressively drive the explorers away.

**TABLE 3-4: FIELD HAND RUMOR TABLE**

### D12 RUMOR

|    |   |
|----|---|
| 1  | The mad god, Ra, is mustering an army to kill us all. (True)                            |
| 2  | LEADER is frail, and rumor has it that his/her own people plot to kill him/her. (False) |
| 3  | Beware, for a mighty beast lives in the desert on the ground floor. (True)              |
| 4  | Be careful how you speak. The mad god, Ra, is always listening. (False)                 |
| 5  | LEADER was mortally wounded, and now his/her brain is kept alive in a jar. (False)      |
| 6  | The City of the Dead is a place of peace where all of the factions congregate. (True)   |
| 7  | Roma-mun of the Black Spear answers to no one, and should be avoided. (True)            |
| 8  | Royalty from all three factions dine together in peace in The Majestic Luxor. (False)   |
| 9  | A magic box hidden in The Sphinx bestows wondrous powers on any who touch it. (False)   |
| 10 | LEADER is insane, and is planning to destroy Ra. (False)                                |
| 11 | None who enter the pyramid of Queen Henut-sun have ever returned. (True)                |
| 12 | Ancient Sobek in the Mediterranean grants boons to those who worship him. (False)       |

**Note:** The field hands will never tell rumors about their own faction's leader. If a rumor has the keyword "LEADER," then replace it with any leader's name that is not the leader for the field hand being interviewed.

Followers of Anubis – Pharaoh Khaframeresh (male)

Eyes of Horus – Nimhotep the vizier (male)

Grace of Isis – Princess Satiah-Kar (female)

## AREA B-6: PYRAMID OF QUEEN HENUTSUN

---

Read or paraphrase the following when explorers enter this area:

**A grand pyramid stands before you; light reflecting off of The Nile glitters on the smooth golden face of the pyramid. A holographic marquee illuminating the top half of the pyramid advertises it as “The Pyramid of Queen Henutsun.” You also see a large pile of garbage and debris that has been formed into a 2m high wall that completely encircles the pyramid. Signs spaced out on the wall declare, “Danger! Keep Out!”**

All three factions helped build the makeshift wall around the pyramid. No one who enters has ever returned alive. The pyramid was a popular tourist attraction before the accident that befell the Warden, so afterwards the insane A.I., Ra, reconstructed the interior into a deathtrap. The Starship Master may consider placing an NPC mutant field hand here to warn the explorers away from the pyramid. If the wall, signs, and NPC are not enough to deter the explorers from entering the pyramid, then their fate is in their own hands.

## AREA B-7: RED SANDS

---

Read or paraphrase the following when explorers enter this area:

**A large area of earth is covered coarse gravel and sand; the whole area is lined by white stones. You can see that much of the sand in the center of the area is stained red. A large security robot slowly drifts over the field; the weapons systems appear to be in stand-by mode.**

Explorers with a red security, blue and red command, black military, or navy administration ships system band are cleared to communicate with the security robot. The robot’s designation is stenciled on its chassis, THX-1138. If questioned, THX-1138 explains that this area is the designated contest field, and that all conflicts between the factions are settled here. Once a contest has been completed, THX-1138 officially declares the victor and then disposes of any remains left in the field.

**THX-1138 (security robot)** – AC: 1; hp: 300. This model robot is equipped with four 4m long manipulation tentacles, each tipped with a paralysis knob (WC: 4; Dmg: Special), anti-gravity propulsion, and an acid disintegration spray (WC: 8; Dmg: 30 pts).

- **Paralysis Knob:** With a successful attack roll, compare the energy strength of 14 versus the target’s CON value on the Poison Chart. A value of star (\*) results in a shock that forces the target to lose initiative on the next round. A numeric value result is the damage the target takes, in addition to the loss of initiative on the next round. And a value of “D” results in full body muscle spasm for d6+1 combat rounds; the target can take no actions during the spasm. The weapon uses a hydrogen power cell with 25 uses before the cell must be changed or recharged. WC: 4; Dmg: Special.
- **Disintegration Spray:** Lethal acidic chemical designed to destroy proteins. This weapon is typically not used offensively. THX-1138 uses the spray to dissolve defeated combatants in the contest field. The spray has a 2m range. WC: 8; Dmg: 30 pts.

If the explorers enter the contest field, THX-1138 goes into alert mode as it observes the combatants. If the combatants do not start battling one another, THX-1138 announces that a victor has not been determined, and that the combatants may not leave the contest field until there is a decisive victor. If the combatants do not start battling each other, then THX-1138 initiates combat in order to cull out the weak; THX-1138 will do the same if only a single combatant enters the contest field.

## AREA B-8: THE SOURCE

---

Read or paraphrase the following when explorers enter this area:

Before you is a large pond; a small blue pyramid in the pond sprays a fountain of water out from the top. The lands around the pond are lush with blue-green grasses, palm trees, and a variety of other plant life.

This is the source of The Nile. This area of the Egyptian complex is both beautiful and deadly; a variety of dangerous plants have taken root here. The wolfoids generally keep clear of the area, but they do use it on occasion to test and train young warriors.

The Starship Master can roll on the table below to randomize a veggie encounter or select one.

## THE PYRAMID OF QUEEN HENUTSUN

The outline of a door is visible at the base of the pyramid's north face. There is a small black glass panel next to the door. If an explorer touches a ship systems band of any color to the panel, the door whooshes open. Beyond the door is a narrow hallway; it is so narrow that the explorers must walk in a single file. The hallway goes ahead 6m; it leads to an upward sloped passage lined with handholds and toeholds for an easy ascent. As soon as the hallway that leads to the slope is empty, the door to the outside behind them slides shut; a small black glass panel in the hallway next to the door can reopen the door. The slope leads up to Area P-1: The Servant's Chamber.

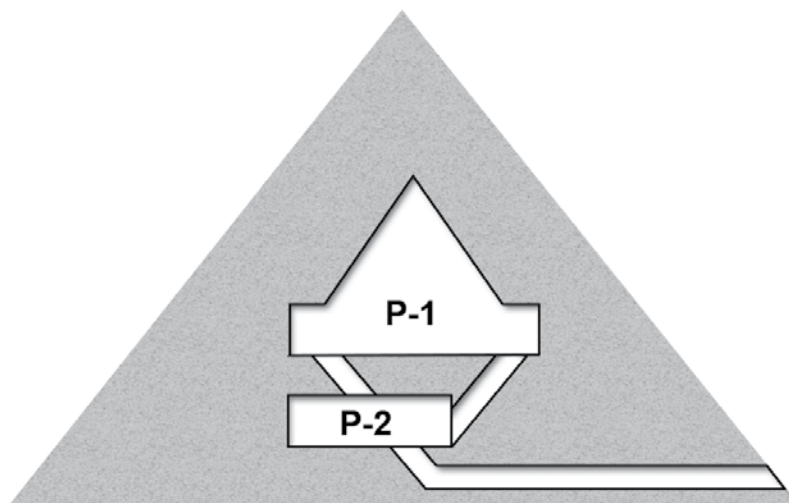

Pyramid of Queen Henutsun

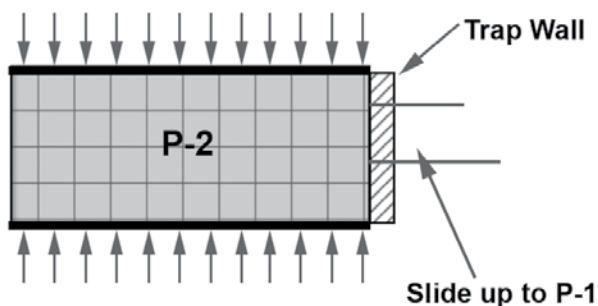
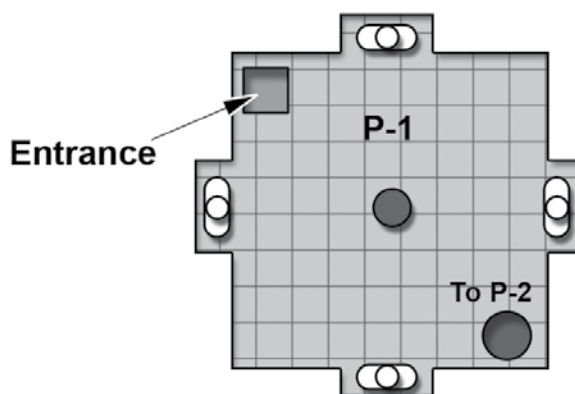

## AREA P-1: THE SERVANT'S CHAMBER

Read or paraphrase the following when explorers enter this area:

**The slope leads up to a pyramid-shaped room. A red sphere hangs from the pinnacle of the ceiling, and as you enter it begins to light the room in warm red light. Within a recess on each wall stands a single golden figure. In the north and south recesses stands a golden man with a falcon's head; he wears only a loincloth and he holds a crook and flail over his bare chest. In the west and east recesses stands a golden woman with a cat's head; she wears only a loincloth and she holds a crook and flail over her bare chest. They are the Servants of Ra.**

The walls and floors of this room are metal, smooth, and highly reflective. The Servants of Ra are obviously humanoid robots, and they too are shiny and reflective. As soon as the slope leading up to this room is empty a metal door slides closed over it, and then a metal iris slips open in the opposite corner of the room. As soon as the iris door opens, the red sphere pulses with the voice of Ra: **"Welcome to the servant's chamber for Queen Henutsun; prepare to be processed."**

It is at this moment that the four Servants of Ra begin to step forward; both the crook and flail begin to crackle with blue energy.

**Servants of Ra Robot (4)** – AC: 3; hp: 100. Each robot wields a paralysis rod (crook; WC: 4; Dmg: Special), and a plasma lash (flail; WC: 3; Dmg: 15 pts.). The robots' skin is completely reflective against laser energy. Each weapon currently has 2d10 uses before needing to be recharged.

- **Crook – Paralysis Rod:** Energy rod with an insulated rubber handle and smooth metal body curved into a crook at the end. With a successful attack roll, compare the energy strength of 12 versus the target's CON value on the Poison Chart. A value of star (\*) results in a shock that forces the target to lose initiative on the next round. A numeric value result is the damage the target takes, in addition to the loss of initiative on the next round. And a value of "D" results in full

body muscle spasm for d6+1 combat rounds; the target can take no actions during the spasm. The weapon uses a hydrogen power cell with 25 uses before the cell must be changed or recharged. WC: 4; Dmg: Special.

- **Flail – Plasma Lash:** Lethal energy whip with an insulated rubber handle and three metal flail chains. With a successful attack roll, the flail inflicts 15 points of plasma burn damage to the target. The weapon uses a hydrogen power cell with 25 uses before the cell must be changed or recharged. WC: 3; Dmg: 15 pts.

In the event that the robots are all defeated, then the red sphere hanging from the ceiling begins to glow even brighter as it fires a laser once every third combat round. Due to the reflective surfaces in this room, the laser bolts are designed to ricochet throughout the room. During the combat round when the red sphere shoots, compare WC: 6 against the target's AC. If the bolt misses, then pick a new target in the next combat round for the first ricochet; the attack roll is WC: 6 with a -2 penalty on the die roll. If the bolt misses again, then pick a new target in the next combat round for the second ricochet; the attack roll is WC: 6 with a -4 penalty on the roll. If the bolt misses again, the energy dissipates. A successful hit inflicts 10d6 damage.

The iris door opened over a smooth metal tube slide. Anyone who uses this exit slides quickly down to P-2: The Queen's Chamber. The slide can only accommodate creatures of average and small sizes; it's too small for large creatures. The metal door over the slope into this room is destroyed after it sustains 100 points of damage.

## AREA P-2: THE QUEEN'S CHAMBER

Read or paraphrase the following when explorers slide into this area:

**The swift slide terminates into a small room. The floor of the room is covered in thousands of small finger-width holes. The walls are decorated with exquisite hieroglyphic murals depicting the murder of a queen, the burial of the queen, and the mourning of Ra over the queen's death.**

This room has a strong chemical smell of ammonia and disinfectants. The walls have some rough wear and tear on them, but they look very solid. The slide into this room is the only obvious entrance or exit. The slide is coated with a frictionless coating making it near impossible to climb up the slide. Explorers attempting this task must make a successful roll on the Mental Strength Table, but instead of comparing Mental Strength versus Mental Strength, it is a Physical Strength versus Physical Strength contest. The “strength” of the slide is 17, read along the vertical axis, versus the explorer’s Physical Strength, read along the horizontal axis. The roll of 3d6 is compared to the number on the chart, and a roll result equal-to or greater than the number is a successful climb of 2m. The full length of the slide is 6m, so an explorer must make three successful rolls to climb out of the slide. If anyone comes sliding down the slide while it is being climbed, both people slide down to Area P-2: The Queen’s Chamber.

Once someone enters at least half-way into the room, a sensor is triggered and a metal wall slams down to cover the entire wall with the slide entrance.

Once the metal wall is down, a holographic image of beautiful Queen Henutsun in the arms of Ra is displayed. Ra turns his head to look at the explorers and says, “**All shall pay for the death of perfection.**” At that moment, the long walls of the room begin to push in together.

The metal wall over the slide is covered in dents and scratches; it has clearly been assaulted before. If the wall takes an additional 200 points of damage, a hole is created that is large enough for average sized people to crawl through. At 150 points of damage, a small person can crawl through. The walls move 10cm per combat round, so it takes twenty combat rounds for the walls to crush together. Average size creatures take 6d6 damage per combat round on rounds 15 – 20, and small creatures are damaged on rounds 17 – 20. All creatures are automatically killed on combat round 20. Once the trap resets, an acid is sprayed into the room to break down the remaining matter, and that refuse is then dissolved as it drips through the holes in the floor into a recycling receptacle under the floor.



**TABLE 3-5: THE SOURCE MUTANT PLANTS**

**D6 MUTANT PLANT**

- 1 **Poison Thorn Grass** – DEX: n/a; MR: n/a; RR: 12; CON: n/a; STR: n/a; Move: n/a; AC: 7; HD: 4 per 3m patch; hp: 17; #ATK: 1 poison thorn (WC: 3; Dmg: poison 9); Mutations: POISON THORNS, DISSOLVING JUICES; SP: this blue grass have poisoned thorn tips. As prey unsuspectedly walk into the center of a 3m patch of poison thorn grass, the grasses make a single coordinated attack to try and poison prey to death, so the prey can then be dissolved (Dmg: 4d6) and digested at its leisure.
- 2 **Buzzpalm** – DEX: n/a; MR: n/a; RR: 10; CON: n/a; STR: n/a; Move: n/a; AC: 5; HD: 10; hp: 35; #ATK: 1; Mutations: ROTOR FRONDS, PLASTICITY, HEAT REFLECTION; SP: the buzzpalm looks like a standard palm tree, but when the roots sense movement the tree is able to bend over with while spinning its palm fronds like a buzz saw. The tree is 2m to 4m tall, and it can stretch up to twice its height. The rotating fronds (WC: 5; Dmg: 6d6) have the ability to reflect all heat-based attacks.
- 3 **Ghost Lotus** – DEX: n/a; MR: 13; RR: 17; CON: n/a; STR: n/a; Move: n/a; AC: n/a; HD: 8 per 2m patch; hp: 30; #ATK: 1; Mutations: INSUBSTANTIAL, RADIATION POLLEN; SP: this plant monster grows as a 2m patch of lotus flowers sitting on the surface of the water at the edge of the pond. The flowers seem to constantly sparkle in colors of deep blue, white, and purple. When prey approach the edge of the pond, the flowers appear to explode into a cloud of sparkly radioactive pollen, (Radiation Intensity 13); no attack roll is required. This plant is immune to physical attacks, but is vulnerable to mental attacks.
- 4 **Mecha Plume Thistle** – DEX: n/a; MR: n/a; RR: 14; CON: n/a; STR: n/a; Move: n/a; AC: 3; HD: 10 per 2m patch; hp: 36; #ATK: 1 by weapon or thorn; Mutations: BIOMECHANICAL, EMP THORNS; SP: this plant monster is typically grown over the decaying husks of robots that have been integrated by this plant. This plant can shoot a cluster of electromagnetic pulse thistle-thorns up to 3m distant, (WC: 2, Dmg: special); a successful hit disrupts targeted electronics for 2d6 combat rounds. Starship Masters should roll 1d4 times on the Technological Treasure Table to determine the items that have previously been integrated into the plant’s biomechanical structure; any weapons are usable by the plant and can be recovered if the plant is destroyed.
- 5 **Poppivlad** – DEX: n/a; MR: 16; RR: 9; CON: n/a; STR: n/a; Move: n/a; AC: 7; HD: 6 per 2m patch; hp: 15; #ATK: 1; Mutations: HALLUCINATORY POLLEN, VAMPIRE THORNS; SP: this plant attacks by spraying the hallucinatory pollen, (Range: 3m; Poison Int: 13; Duration: 3d10 minus target’s CON in combat rounds). Victims usually lay down to enjoy the psychedelic hallucinations next to the beautiful flowered plant; that is when the plant reaches over with its vampiric thorns and leaves. Vampire thorn attacks against docile targets do not require an attack roll, otherwise WC: 1, Dmg: special. The vampire thorns drain 1d6 hit points, (blood), from the target, and adds those stolen hit points to the plant.
- 6 **Cat-o’-Nine Tentacles** – DEX: n/a; MR: 10; RR: 13; CON: n/a; STR: 15; Move: n/a; AC: 7; HD: 10 per 3m patch; hp: 35; #ATK: 1; Mutations: DRAGGING VINES, DEEP ROOTS; SP: this huge plant makes its home along the shallow edge of a pond or river as 2 – 4 patches of plants. When prey gets within 4m of the water’s edge, the plant shoots out a cluster of vines, (3d6), from out of the water to entangle the prey, (WC: 2; Dmg: entanglement); each vine has 5 hit points. Each following combat round the Starship Master repurposes the Mental Strength Chart to compare Physical Strength between plant and prey. With a successful roll, the plant is able to drag the prey 1m closer to the water. Once the plant drags prey into the water, the prey takes 2d6 drowning damage per combat round. The plant’s deep root ball is located under the water.

## THIRD FLOOR

The third floor is one of the residential floors. The majority of this floor is claimed by the Followers of Anubis faction, with some of the apartments claimed by the Eyes of Horus faction. There is a 40% chance that explorers encounter a group of wolfoids patrolling their territory. The Followers of Anubis patrol is the same as the charioteer soldiers described in the **Egyptian Complex Perimeter Encounter Table**, minus the vehicle, and the Eyes of Horus patrol is the same as the soldiers described in the same table.

### EGYPTIAN COMPLEX APARTMENTS

---

The living quarters come in three different room sizes, single, double, and family suite apartments. The single has one king-sized bed and washroom. The room also features a small desk, armoire, dresser, and vid-screen. The double has two queen-sized beds, washroom, and the same features as the single apartment. The family suite has one bedroom with a single king-sized bed, a second bedroom with a single queen-sized bed, and a third bedroom with a pair of bunk beds, and two washrooms. The family suite also has two desks, a family lounge that features a large vid-screen, and each bedroom has a dresser, armoire, and vid-screen.

Some of the apartments have been claimed by the wolfoids, some are unused, and some are ruined. In the Egyptian complex, the ruined apartments have a meter of sand or earth piled up and spilling out into the hall, and could be populated by mutated plants or animals. The maintenance robots have long ago abandoned these apartments. The unused apartments are clean and serviceable. The rooms are serviced by the maintenance robots and are available for habitation.

The rooms claimed by the wolfoids, regardless of the room's size, have a family of three to nine wolfoids living there. Much of the furniture has been moved to the walls to make room for the wolfoids to sleep in a pile on the floor. Each wolfoid apartment door has been decorated with a hieroglyphic cartouche that identifies the clan they belong to, be it the Followers of Anubis, the Eyes of Horus, or the Grace of Isis.

## THE FOLLOWERS OF ANUBIS REGION

---

The apartments for this region breakdown like this:

### Single Apartments:

- 60% Unoccupied
- 35% Occupied by Followers of Anubis mutants
- 5% Occupied by creatures

### Double Apartments:

- 55% Occupied by Followers of Anubis wolfoids
- 15% Occupied by Followers of Anubis mutants
- 20% Unoccupied
- 10% Occupied by creatures

### Family Suite Apartments:

- 100% Occupied by Followers of Anubis wolfoids

## THE EYES OF HORUS REGION

---

The apartments for this region breakdown like this:

### Single Apartments:

- 25% Unoccupied
- 50% Occupied by Eyes of Horus wolfoids
- 15% Occupied by Eyes of Horus mutants
- 10% Occupied by creatures

### Double Apartments:

- 65% Occupied by Eyes of Horus wolfoids
- 5% Occupied by Eyes of Horus mutants
- 10% Unoccupied
- 20% Occupied by creatures

### Family Suite Apartments:

- 80% Occupied by Eyes of Horus wolfoids
- 10% Occupied by Eyes of Horus mutants
- 5% Unoccupied
- 5% Occupied by creatures

The Starship Master is encouraged to determine which specific apartments are unoccupied or occupied by wolfoids, mutants, or creatures. All manner of mutant creatures or plants have taken refuge in some of these apartments. The Starship Master may design something living there, or reference the mutant plants listed in Area B-8: The Source above.

## AREA C-1: TURBO LIFTS & STAIRS

---

Same as Area A-3: Turbo Lifts & Stairs above.

## AREA C-2: THE PALACE OF PHARAOH KHAFRAMERESH

---

Read or paraphrase the following when explorers enter this area:

**All of the apartments flanking this hallway have been retrofitted into a single palace suite, and at the end of the hall is an opulent home that is clearly befitting of royalty. A squadron of soldiers stands at attention, ready to spring into action at their Pharaoh's command. Wolfoid and mutant concubines watch you in fascination.**

A squad of soldiers is always on guard in the palace. Pharaoh Khaframeresh has no queen, so concubines are also always lurking about in the palace. The Pharaoh does not conduct any official business in the palace, but this is where he spends a majority of his time. The palace features a variety of rooms, all of which serve to make the Pharaoh as comfortable as possible. There are multiple bedrooms, baths, dining rooms, and parlors.

**Palace Guards (wolfoids) (8 – 12)** – DEX: 14; MR: 15; RR: 17; CON: 16; STR: 16; Move: 12; AC: 3; HD: 17; hp: 55 each; #ATK: 1 long spear (WC: 2; Dmg: 10 pts), or claws (WC: 3; Dmg: 1d4+1); Mutations: SCALED SKIN, LIGHT ABSORPTION; SP: the scaled skin: kinetic absorption that reduces physical damage by 5 pts, and the light absorption: heals 6 Hit Points when hit by laser attacks, and is immune to all forms of laser and light attacks.

**Concubines (wolfoids) (6 – 8)** – DEX: 10; MR: 17; RR: 11; CON: 11; STR: 12; Move: 12; AC: 6; HD: 12; hp: 44 each; #ATK: 1 claws (WC: 3; Dmg: 1d4+1); Mutations: SCALED SKIN, LIGHT ABSORPTION; SP: the scaled skin: kinetic absorption that reduces physical damage by 3 pts, and the light absorption: heals 4 Hit Points when hit by laser attacks, and is immune to all forms of laser and light attacks.

**Concubines (mutants) (2 – 4)** – DEX: 14; MR: 15; RR: 17; CON: 16; STR: 16; Move: 12; AC: 3; HD: 10; hp: 38 each; #ATK: 1; Mutations: 1 RANDOM PHYSICAL, AND 1 RANDOM MENTAL; SP: only one of the concubine's mutations is offensive.

Pharaoh Khaframeresh's private bedchamber has a large circular sunken area in the center of the room that is filled with blood red satin pillows. This is where the Pharaoh sleeps. If this area is searched, a concealed door is found under the pillows. The door is unlocked, and within is hidden two of the Pharaoh's prized treasures: a gamma revolver with safety gloves and a box of 20 gamma rounds, and a box of a dozen sticky mist grenades. Both of these weapons are described in detail in *The Warden Armory* sourcebook.

## AREA C-3: THE THRONE

---

Read or paraphrase the following when explorers enter this area:

**The ground is covered in crushed limestone gravel. A broad road lined with white marble columns leads directly to a large stage that is also lined with marble columns. In the center of the stage, facing the road, is a grand throne. The throne sits at the top of a tier dais; six steps lead up to the throne. Standing by each column on the stage is wolfoid guard.**

Day or night, a squad of wolfoid palace guards stands at attention around the throne. If Pharaoh Khaframeresh is not in his palace, he is here exacting cruel justice, for he is a sociopath and the current ruler of the entire Egyptian complex. Pharaoh Khaframeresh's right-hand man is Nebutu, a mutant who is the Pharaoh's personal physician.

**Pharaoh Khaframeresh (wolfoid)** – DEX: 15; MR: 17; RR: 14; CON: 15; STR: 17; Move: 12; AC: 3; HD: 18; hp: 65; #ATK: 1 vibro-sword (WC: 4; Dmg: 35 pts), or claws (WC: 3; Dmg: 1d4+1); Mutations: SCALED SKIN, LIGHT ABSORPTION, EXTRA BODY PART (HEAD), RADIATED EYES; SP: the scaled skin: kinetic absorption that reduces physical damage by 5 pts, and the light absorption: heals 6 Hit Points when hit by laser attacks, and is immune to all forms of laser and light attacks. Khaframeresh's second face is located on the back of his head, and it whispers gibberish to him day and night; the constant gibbering has driven Khaframeresh insane. Khaframeresh usually hides his second face with his ceremonial headdress. The second face possesses the mutant ability of radiated eyes, (Rad: 10; Range: 4m), though Khaframeresh's primary face does not possess this ability.



# EGYPTIAN COMPLEX

## Map 3

### Third Floor

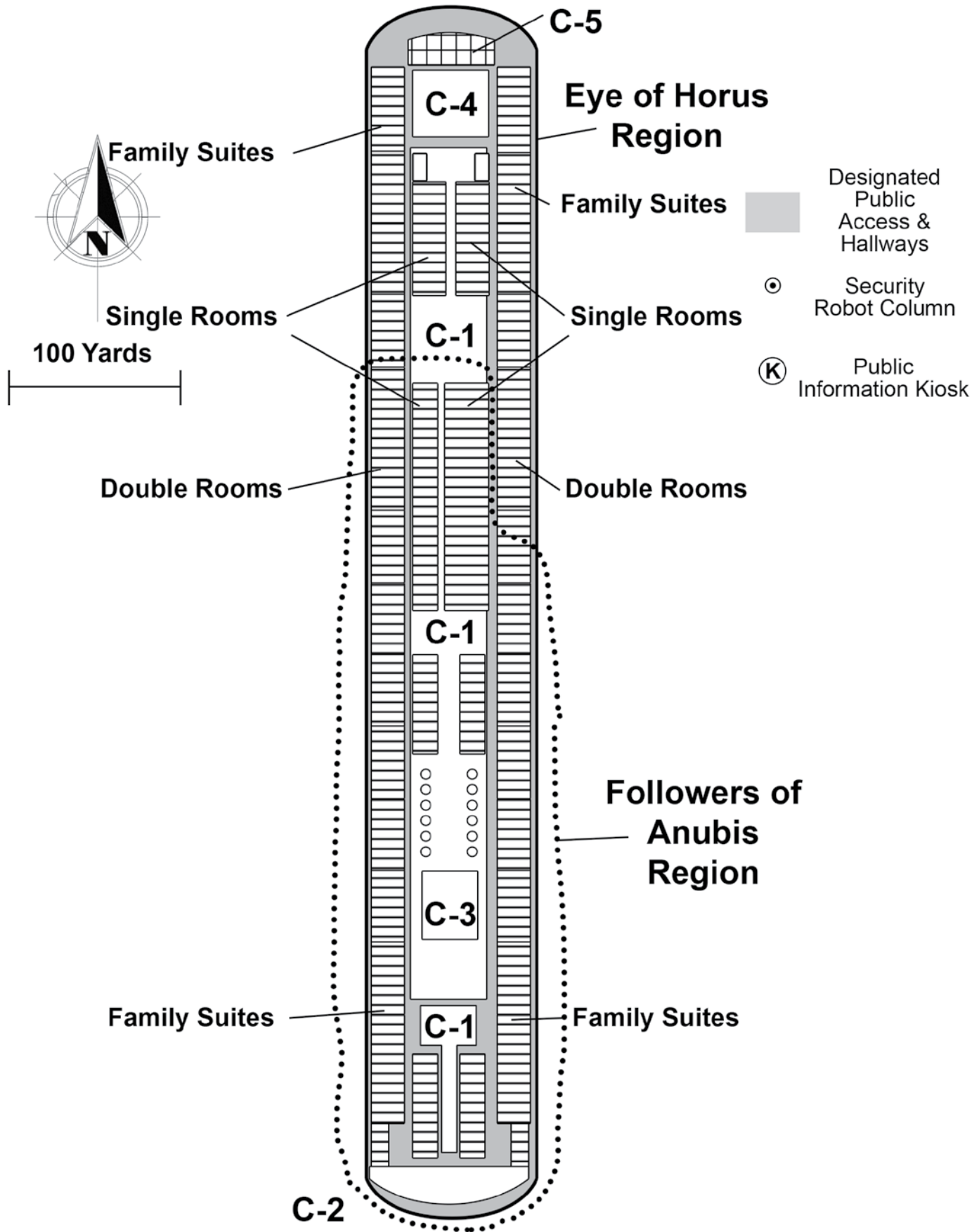

**Nebutu (mutant)** – DEX: 10; MR: 11; RR: 12; CON: 14; STR: 11; Move: 12; AC: 6; HD: 15; hp: 48; #ATK: 1 vibro-knife (WC: 4; Dmg: 25 pts); Mutations: PLASTICITY, PREHENSILE TONGUE, MENTAL BOMB; SP: the mutant is a skilled physician, but he is also capable of detonating a devastating mental attack.

---

### AREA C-4: THE BAZAAR

---

Read or paraphrase the following when explorers enter this area during daytime hours:

**Throng of wofoids and mutants fill the market square before you. The square is lined with brightly colored tents, and the merchants within the tents have a wide variety of goods for sale. You observe transactions both paid in domars and bartered in trade. You can also feel the crowd's eyes watching you with caution.**

Or, read or paraphrase the following when explorers enter this area during nighttime hours:

**Before you is a market square; it is lined by brightly colored tents, but each tent is tied closed. The bazaar is closed, but you still have that feeling that you are being watched.**

The Eyes of Horus wofoids are more tolerant of strangers than the Followers of Anubis are, but they do keep a careful eye on newcomers. The bazaar is organized and operated by Shirr, a cunning and ruthless merchant. Shirr employs enforcer mutants to keep the peace and protect the merchants that do business here, and in return, Shirr gets a cut of their profits. Shirr's enforcers are always on the lookout for trouble, and if anyone causes a ruckus, then the enforcers move in to put an end to it. Shirr lives in one of the nearby single room apartments; he runs his entire business from there. Shirr has a cache of 2500 domars hidden in a box in his apartment.

**Shirr (mutant cyborg)** – DEX: 12; MR: 18; RR: 9; CON: 15; STR: 11; Move: 10; AC: 4; HD: 15; hp: 105 each; #ATK: 1 slug projector – T2 (WC: 3; Dmg: 3d6 or 6d6 vs AC 7 or 8), or dagger (WC: 3; Dmg: 1d4); Mutations: HEIGHTENED INTELLIGENCE, FIND FAULT, PHANTOM HAND; Cybernetics: *repair unit, computer hack head*; SP: this mutant cyborg has a silver skull cap that has three prehensile cables that can jack into computers for mental hacking of the

computer. Shirr has a pair of intimidating black arced lightning bolts painted on either side of his skull cap. Shirr's back is covered in metal plating with six large metal blisters on the plating; this portable medical unit has a one-time use to repair 20 hit points of biological damage. Once used, Shirr has to have the repair unit recharged before it can heal him again.

**Enforcers (mutant clones) (14)** – DEX: 14; MR: 8; RR: 11; CON: 16; STR: 17; Move: 10; AC: 4; HD: 16; hp: 53 each; #ATK: 1 fire ax (WC: 3; Dmg: 1d8), or pipe wrench (WC: 3; Dmg: 1d8+2), or broad sword (WC: 3; Dmg: 1d8), or cold generation mutation (Dmg: 10d6 once per day); Mutations: MASS MIND, COMPOUND EYES, COLD GENERATION; SP: these mutants are all clones of each other. They don't have names, Shirr calls them by numbers.

---

### AREA C-5: BLACK SANDS CAFÉ

---

Read or paraphrase the following when explorers enter this area:

**The holographic sign announces this as “The Black Sands Café.” The restaurant is well lit with patrons seated at most of the tables.**

This restaurant welcomes all who want to come inside. The restaurant has a pretty standard list of meals on the menu, but there is one dish not listed on the menu... human hands. Hands are a delicacy for wofoids, and whenever possible, this restaurant makes it available.

If a true human ever dines here, their food is laced with an odorless and tasteless poison designed to knock the victim unconscious. Poison intensity 10. If the poison is effective, the victim becomes drowsy and will fall unconscious in 3d6 minutes, and will either take 1, 2, or 3 points of damage, or 1d3+3 points of damage with a result of “D” on the Poison Table.

The café employees use the same stats as the Eyes of Horus Soldiers in the Egyptian Complex Perimeter Encounter Table, but without any weapons; the employees only use claws or kitchen daggers, (WC: 3; Dmg: 1d4).

## FOURTH FLOOR

The fourth floor is one of the residential floors. Half of this floor is claimed by the the Eyes of Horus faction, and the other half by the Grace of Isis faction. There is a 40% chance that explorers encounter a group of wolfoids patrolling their territory. The Eyes of Horus patrol is the same as the soldiers described in the **Egyptian Complex Perimeter Encounter Table**, and the Grace of Isis patrol is the same as the infantry described in the same table.

### THE EYES OF HORUS REGION

---

The apartments for this region breakdown like this:

Single Apartments:

- 40% Unoccupied
- 45% Occupied by Eyes of Horus mutants
- 10% Occupied by Eyes of Horus wolfoids
- 5% Occupied by creatures

Double Apartments:

- 65% Occupied by Eyes of Horus wolfoids
- 10% Occupied by Eyes of Horus mutants
- 10% Unoccupied
- 15% Occupied by creatures

Family Suite Apartments:

- 100% Occupied by Eyes of Horus wolfoids

### THE GRACE OF ISIS

---

The apartments for this region breakdown like this:

Single Apartments:

- 35% Unoccupied
- 30% Occupied by Grace of Isis wolfoids
- 25% Occupied by Grace of Isis mutants
- 10% Occupied by creatures

Double Apartments:

- 50% Occupied by Grace of Isis wolfoids
- 15% Occupied by Grace of Isis mutants

- 20% Unoccupied
- 15% Occupied by creatures

Family Suite Apartments:

- 100% Occupied by Grace of Isis wolfoids

The Starship Master is encouraged to determine which specific apartments are unoccupied or occupied by wolfoids, mutants, or creatures. All manner of mutant creatures or plants have taken refuge in some of these apartments. The Starship Master may design something living there, or reference the mutant plants listed in Area B-8: The Source above.

### AREA D-1: TURBO LIFTS & STAIRS

---

Same description as Area A-3: Turbo Lifts & Stairs above.

### AREA D-2: THE OBSERVATORY

---

Read or paraphrase the following when explorers enter this area:

**This amazing collection of suites has been retrofitted into a sleek structure with a huge convex wall that bubbles out over the Epsilon City skyline. A squad of Eyes of Horus soldiers stands at attention outside, and a holographic marquee advertises this building as The Observatory.**

A squad of a six soldiers is always on guard outside of this location. Nimhotep, the leader of the Eyes of Horus faction, has made the observatory his home. It is also a place of study; a large computer library with data about ancient Earth and the Warden starship are accessible here. Nimhotep is aware of the truth that their world exists within a generational starship that is lost in space, and he is careful to keep this information secret from the general population.

The guards are instructed to challenge anyone who wants to enter the observatory, but not to attack anyone except in self-defense. If anyone is able to present a light blue sciences or a red and blue command ships systems band, then that person and his entourage are cleared to enter the observatory. Otherwise, the guards contact Aya, Nimhotep's personal aid, for her to clear strangers for entry.

# EGYPTIAN COMPLEX

## Map 4

### Fourth Floor

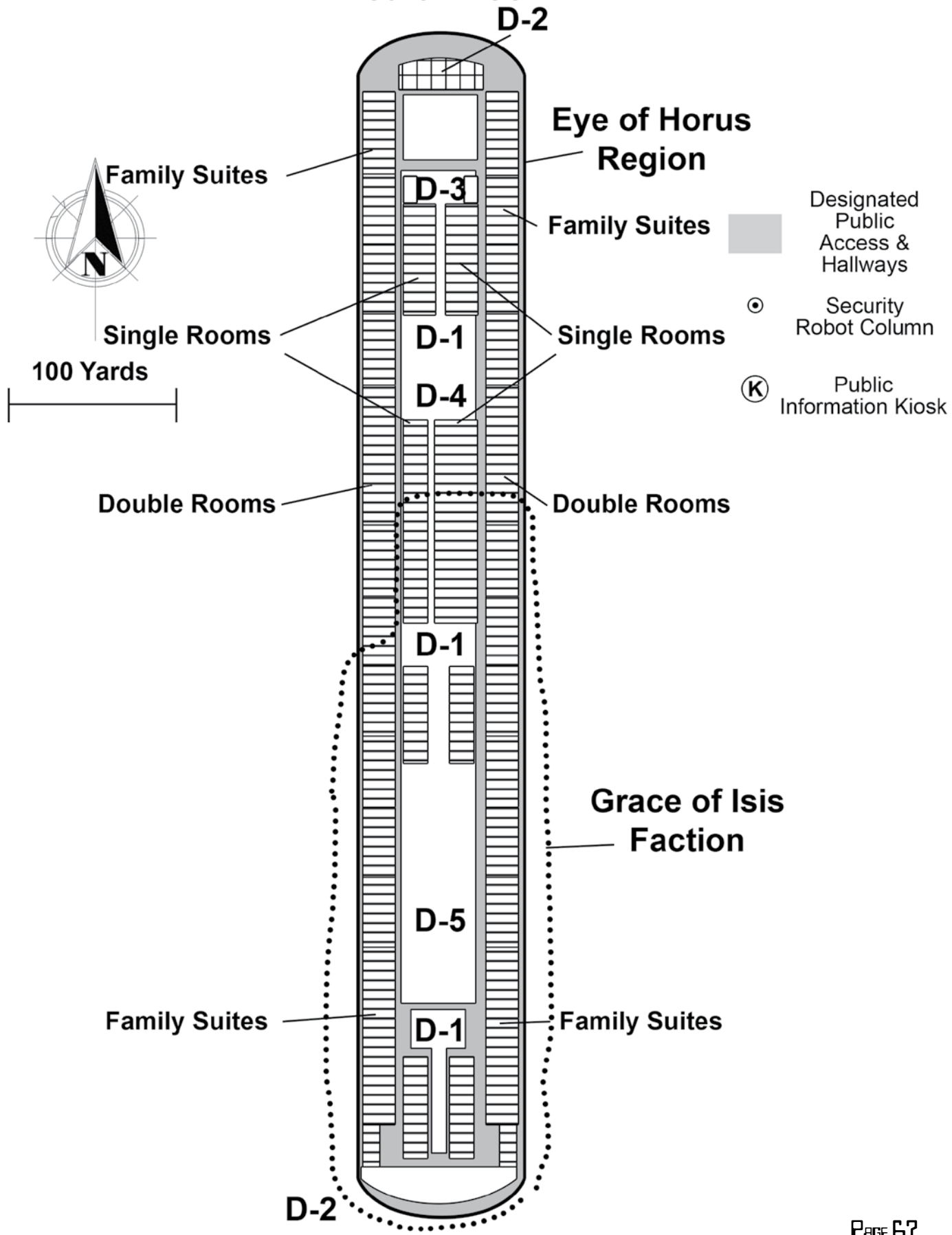

The computer library in the observatory has a responsive A.I. known as Behkenu; it has an Item Complexity Rating (ICR) 10. Unless the user has a science or command ships systems band, then Behkenu has an ICR 6 rating. If an explorer is able to successfully access Behkenu, then a wealth of information about ancient Earth and the truth about the starship *Warden* are available to be discovered. Behkenu uses the large convex wall to display star patterns so astronomers can study the universe.

Note – The Starship Master is encouraged to make it very difficult for explorers to gain access to Behkenu, and even if they gain access it should be difficult for explorers to gain any additional information. Behkenu uses a great deal of technical jargon and a considerable amount of its data is out of date.

**Vizier Nimhotep (wolfoid)** – DEX: 17; MR: 16; RR: 13; CON: 11; STR: 8; Move: 10; AC: 6; HD: 14; hp: 49; #ATK: 1 sonic pistol (WC: 6; Dmg: 35/20/10 pts), or claws (WC: 3; Dmg: 1d4+1); Mutations: HEIGHTENED VISION, HUSK, MOLECULAR DISRUPTION; SP: Nimhotep is an albino, with white fur and pink eyes. His enhanced vision bestows a +2 bonus on all attack rolls. His husk ability can heal 3 pts of damage by shedding the injured skin, (limited to 3 pts of damage per single injury). His molecular disruption ability is a power of last resort; it can be used only once per week, and when used it reduces Nimhotep to one hit point for seven days. The power utterly dematerializes matter from existence: 48% vs 50 kg of metal and dense material, 64% vs 50 kg of stone and non-metal material, and 80% vs man-sized biological material. Nimhotep wears a light blue sciences ship systems band.

**Aya (wolfoid)** – DEX: 13; MR: 12; RR: 15; CON: 15; STR: 13; Move: 10; AC: 6; HD: 15; hp: 52; #ATK: 1 pepper pistol (WC: 7; Dmg: incapacitated for 3 min.) or claws (WC: 3; Dmg: 1d4+1); Mutations: HEIGHTENED VISION, HUSK, WEB; SP: Aya has grey fur with white highlights around her throat, brow, and ears. She abhors violence, and usually fights to subdue rather than kill.

---

### AREA D-3: THE FIELD OF SWORDS

---

Read or paraphrase the following when explorers enter this area:

**Before you is a trimmed lawn, green and lush. Doz-**

**ens of wolfoid and mutant Eyes of Horus soldiers are sparring as they practice with sword, spear, and shield. A few of the wolfoids drill sergeants have turned to look your way, clearly wondering what you are doing here.**

The Eyes of Horus faction of wolfoids is cautious: their philosophy is to ask questions first, and then if necessary, attack second. If the explorers ask peacefully, the wolfoid drill sergeants will give them some basic combat lessons. The lesson lasts for only an hour, but it is quite intense. The player then rolls percentile dice, and if the result is equal to or less than the average of their Dexterity, Mental Resistance, and Strength, then that explorer has earned a permanent +1 bonus to melee attacks with the weapon they trained with.

---

### AREA D-4: THE GENERATORS

---

Read or paraphrase the following when explorers enter this area:

**You can feel, ever so slightly, the ground vibrating under your feet. Before you is an immense white structure covered in blinking and strobing lights; it occasionally vents steam from a number of grated ports. Surrounding the structure columns of security robots; the robots are evenly spaced 4m apart from each other all the way around the structure.**

This is the primary power source for the entire Egyptian complex. It is so large, that it is virtually impossible to utterly destroy it, but any damage to the generator does diminish Ra's ability to control the complex. Ra (the insane A.I. within the Egyptian complex), has stationed 36 security robot columns, (the same as noted in the Egyptian Complex Interior Encounter Table above), around the generator to protect it. The generator has a metallic exterior that functions as AC 2, and each 2m square section has 30 hit points of defense. If a section of the exterior skin is destroyed, then every point of damage inflicted to the interior of the generator equates to a number of hours required to repair the generator. While the generator is damaged, any action Ra takes only has half of the chance to succeed, (for example, reduce attack rolls by half, and reduce percentile die rolls by half), and Ra's protective force field (see The Roof) drops. At 500 points of interior damage, Ra is completely incapacitated until the automated repairs can be completed.

## AREA D-5: THE PLAZA & TEMPLE OF ISIS

---

Read or paraphrase the following when explorers enter this area:

**The sandy field is lined with marble columns that lead to an ornate temple. Clerics and priestesses leisurely stroll through the plaza, each with a snake draped over their shoulders. Slithering through the sands are dozens and dozens of asps, cobras, and black mambas.**

The Grace of Isis wolfoids are snake handlers. The faith and discipline required to handle vipers is the same that guides their worship of the goddess Isis. A subsonic fence keeps the snakes contained within the plaza. The temple is not only used for their worship of Isis, but it is also a where the Grace of Isis faction stockpiles weapons in preparation for a war with the Followers of Anubis.

Anyone not part of the Grace of Isis faction is dissuaded from entering the plaza; the clerics and priestesses warn strangers that the snakes are dangerous, and for their own safety they need to stay out of the plaza. But, in reality, the clerics and priestesses are warning the explorers away because they are trying to keep their armory a secret. If explorers insist on entering the temple to Isis, then the Grace of Isis wolfoids fallback to defend the temple using anything and everything at their disposal.

The snakes are more afraid of the explorers than they may be of them. Each explorer has a 20% chance of being attacked by snake; per combat round spend in the plaza.

**Snake (any type)** – DEX: 18; MR: n/a; RR: n/a; CON: 4; STR: n/a; Move: 20; AC: 4; HD: 4; hp: 15 each; #ATK: 1 bite (WC: 3; Dmg: 1 pts and Poison 16.); SP: when comparing the snake's poison against the victim's CON on the Poison Table, a numeric result is the penalty the victim has on subsequent attack rolls. A "D" result is a penalty of "-5" on subsequent attack rolls. If a victim is bit multiple times, the penalty values are compounded. If a victim ever receives a third "D" result from a snake bite, then that victim dies. Med-packs can cleanse the victim's blood and remove all traces of venom, but any new snake bites still require additional medical treatments.

The weapons stockpile hidden inside the temple to

Isis is quite extensive and very well organized and catalogued. There are dozens of swords, daggers, and armored vests stored in plastic crates in the temple's front foyer, but the real cache is locked within the main hall. The door to the main hall has been retrofitted with a military grade magnetic lock; a black military ship systems band is required to open the door. The leader of the Grace of Isis, Princess Satiah-Kar, her counselor, Yaga-boo, one trusted cleric, and one trusted priestesses are the only ones in this complex who possess a black band. Inside the main hall are crates of various vibro-blades, lasers, disruptors, and grenades; and a large supply of energy cells to keep the weapons charged. Also available are two suits of light mobile scout armor, and one suit of medium mobile defense armor; all three suits have been decorated with the Grace of Isis color schemes and hieroglyph cartouches.

## AREA D-6: THE OASIS

---

Read or paraphrase the following when explorers enter this area:

**The family suite apartments at this end of the building have been retrofitted into a single suite. Many of the walls have been removed to create a wide open space. That space has an earthen floor, and lush vegetation grows throughout this area. There are lush trees and bushes ripe with fruit, berries, and wide fronds. An ornate tent has been erected near the huge window that overlooks Epsilon City below.**

The tent is home to Princess Satiah-Kar. She spends most of her time here meditating and planning a war against the Followers of Anubis. The planned war is a close-kept secret, and very few members of the Grace of Isis are aware of the princess' intention to start a war. Princess Satiah-Kar is happy to entertain visitors in her home, but if the topic of war is raised, or if anyone accuses Princess Satiah-Kar of preparing for war, then she becomes hostile and will do anything to insure that her secret war plans are kept secret. Princess Satiah-Kar is never met alone; her councilor, Yaga-boo, a golden bearoid, is always with her. Both Princess Satiah-Kar and Yaga-boo wear black military ship systems bands; the princess also wears a lanyard around her neck that has a white plastic card clipped to it. If anyone presses their thumb to the white card, a small hologram is projected of a man in a blue and white Naval uniform; the man says, "**You are cordially invited**

to the captain's table for dinner. We look forward to the pleasure of your company. Formal attire is required." The holographic recording then ends. This artifact is revered by the wolfoids because the invitation predates the cataclysm that forever changed life aboard the *Warden*.

**Princess Satiah-Kar (wolfoid)** – DEX: 15; MR: 14; RR: 14; CON: 15; STR: 13; Move: 12; AC: 4; HD: 15; hp: 52; #ATK: 1 plasma staff (WC: 2; Dmg: 50 pts), or claws (WC: 3; Dmg: 1d4+1); Mutations: METALLIC SKIN, ILLUSION GENERATION, PHASING; SP: Satiah-Kar is paranoid and suspicious of all strangers; Yaga-boo is the only non-wolfoid that has earned her trust. Satiah-Kar's plasma spear is a 2m long rod with a "live" plasma tip at one end; the weapon is powered by two hydrogen cells loaded in the opposite end of the staff.

**Yaga-boo (bearoid)** – DEX: 9; MR: 16; RR: 9; CON: 17; STR: 18; Move: 10; AC: 4; HD: 18; hp: 70; #ATK: 1 tranquil dart pistol (WC: 4; Poison: 10.) or claws (WC: 3; Dmg: 1d6+1); Mutations: TELEPORTATION, PRECOGNITION, TELEPATHY, MENTAL CONTROL, NEAR SIGHTED (D), NO RESISTANCE TO PARALYSIS OR GAS ATTACKS (D); SP: Yaga-boo has fluffy golden fur with dark accents on her paws and forehead. If the poison in the tranquilizer dart is successful, the victim is knocked unconscious for 30 minutes. A numeric value on the Poison Table is a penalty on the victims combat die rolls for the next 30 minutes. Multiple dart attacks may compound the penalty die rolls for a victim.

## THE ROOF

The fifth floor is wholly controlled by Ra, the insane A.I. in charge of the Egyptian complex. Ra itself is a 5m diameter red sphere that is mounted on top of a 3m tall and 1m diameter titanium pole at the south end of the roof. The entire roof is protected by a powerful force field that shines with a golden nimbus. The force field generator emits a 300-point protective shield, but if the Egyptian complex power generator located in Area D-4 takes any internal damage, the force field drops until repairs are completed to the power generators. The force field only protects the roof from external attacks, but Ra can be attacked if the aggressors enter from within the complex.

Four laser turrets controlled by Ra are mounted outside of the force field. Each turret has AC 2, and can withstand 50 points of damage before becoming inoperable. Each turret has 270 degree firing arc, so there is plenty of overlap coverage away from the roof. The turrets are not able to fire at targets located on the roof itself. These laser turrets are controlled by Ra.

If the force field falls, or if Ra is being attacked inside the force field, then Ra has one heavy hover attack droid available to defend it. When at rest, the droid is docked in a power station on the floor under the sphere, Ra.

## EGYPTIAN COMPLEX

Map 5  
Sky Floor

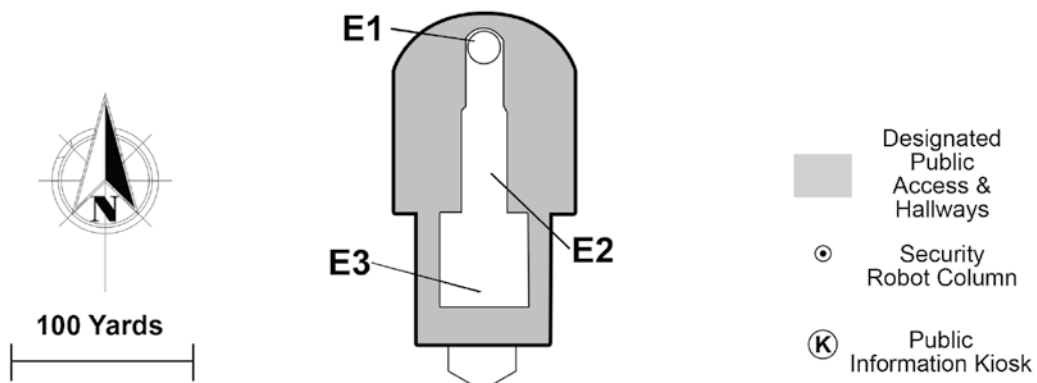

## AREA E-3: THE SUN GOD

---

Read or paraphrase the following when explorers enter this area:

**The giant red sphere pulses with internal lights that give you the sense that it is alive. You can feel the thing studying you, and then it speaks, “Who dares to come before Ra, God of the Sun, Maker of All-Things, and Supreme Ruler of Egypt?”**

Ra is content to answer questions posed to it by explorers; the Starship Master is encouraged to make Ra’s responses cryptic, portentous and vague. If the explorers threaten Ra, or if Ra senses that the explorers are attempting to ask conflicting logic questions in an attempt to confuse its programming, then Ra will verbally lash out in anger as it activates the heavy hover attack droid.

Ra’s sphere can sustain 200 points of damage, at which point the lights in the sphere go dark and Ra “dies.” The golden force field is automatically controlled by the power generator in Area D-4, so the force field does not go down until that power generator is damaged. But, because the heavy hover attack droid receives all of its power as a broadcast signal from Ra, if Ra goes down, then so does the attack droid.

**Heavy Hover Attack Droid** – This droid measures 2m wide, 1m thick, and 3m tall. This brutal combat droid can float and fly 10m off the ground, but it can deploy a trio of legs for manual movement when required. The droid’s hull has AC 1 and can take 280 structural points of damage before being destroyed, but every 40 points of damage disables one of the droid’s systems.

- Plasma Blaster – WC: 7; Dmg: 200 pts; Ammo: 25 shots
- Gamma Mortar – WC: 7; Rad: 15 (10 minute half-life); Ammo: 6 rounds
- Two Laser Mini-guns (one Forward, one Aft) – WC: 6; Dmg: 15d6 each; Ammo: unlimited
- Two Manipulation Tentacles – 3m long retractable tentacles with three dexterous manipulation “fingers” at the end
- Power Source – Broadcast power from Ra
- Anti-Grav Generators – Provides hover and flight capabilities
- Tripod Legs – Retractable legs for manual locomotion

## AREA E-1: TURBO LIFTS & STAIRS

---

Same as Area A-3: Turbo Lifts & Stairs above.

## AREA E-2: LANDING PAD

---

Read or paraphrase the following when explorers enter this area:

**Clearly, in days gone by, the roof was used to manage air traffic that came to visit the Egyptian complex. The center of the roof is circular landing pad, and parked in the center of the pad is a silver bubble car.**

The vehicle is unlocked; the pilot must possess a brown general-purpose ships systems band and log into the controls with a thumb ID scanner. The ship A.I. will accept up to five individuals as designated pilots. Details on the bubble car are available in the *Metamorphosis Alpha: Creatures and Gadgets* sourcebook published by Goodman Games.



# A36 THE CHEROKEE NATION COMPLEX

BY JON HOOK

## BACKGROUND

Epsilon City, the very pinnacle of fantastic entertainment, luxury apartment homes, and sleek office parks, was the jewel of civilization located in the center of the starship *Warden*. The city was fully automated and self-sustained by an advanced artificial intelligence (A.I.) that commanded a battalion of robots specially designed to service the city.

Three hundred years ago, the ship's A.I. went insane after a radiation cloud wiped out 99% of the colonists and crew. The starship *Warden* was dying, but throughout the ship the biological and technological survivors fought to maintain their environments and forge a new future for themselves. The Epsilon City A.I. did so too, and reprogrammed its robots to suit the new needs of the city. Packs of wolfoids, along with a few other mutants, have claimed Epsilon City as their new lair; they have adapted to the unique challenges of living within the thematic environments of Epsilon City.

The Cherokee Nation complex is populated by wolfoids that adopted the lifestyle of the ancient Cherokee people, after their removal to the Great Plains of North America; they lived off the land, sought a spiritual balance with their bestial nature, and fiercely defended their territory. But a herd of refugee centaurs, in search for a place to call home, invaded the Cherokee Nation complex to claim it as their own. These centaurs adopted the lifestyle of ancient American frontiersmen, and have successfully captured the first two floors of the complex. The Cherokee wolfoids now live in the top three floors of the complex, but they are gathering their forces to reclaim the land that was rightfully theirs.

## THE CHEROKEE NATION OF WOLFOIDS

---

The wolfoids living in this complex wear leather clothing that has been accented with colorful beads and feathers. Each wolfoid's position in the tribe indicated in the decorative pattern on their clothing; the more important they are in the tribe, the more complex the pattern. The tribal hierarchy is Chief, followed by Elders, then Shamans, before Warriors, then Artisans, and finally, Children; the leader of the Cherokee Nation is Chief Gigage Nvda, or Red Star, as it translates in the Cherokee language. The Cherokee Nation of wolfoids are a peaceful people, and were once more than willing to meet and trade goods with strangers, but their trust of strangers was destroyed by the Bucklands. The prolonged conflict with the centaurs has made the Cherokee Nation of wolfoids extremely distrustful of strangers. Chief Red Star is the only being able to communicate with Waya, the Cherokee Nation complex's A.I. Also, while the Cherokee wolfoids still find human hands a delicacy, their drive to reclaim their lands and defeat the Bucklands currently overrides any petty desire they may feel for scrumptious hands and fingers.

## THE BUCKLANDS

---

The Bucklands are a family of centaurs that invaded the Cherokee Nation complex; they drove the wolfoids up into the top three floors of the complex, and have claimed the lower two public floors of the complex as their own. They established a ranch, known as the Ponderosa, and they make a living hunting and processing the bisonoids that live in the complex. The family patriarch is Gran-Pappy Buckland, a surly old cuss who should have "gone out to pasture" a long time ago, but is just too ornery to die.

## THE PERIMETER AND GENERAL INFORMATION

When the explorers first view the Cherokee Nation apartment complex, read or paraphrase the following:

**The building before you has an immense holographic marquee that covers both the ground floor and second floor; the marquee depicts scenes of sweeping majestic vistas of rolling hills of waving grasses, then clear streams flowing over colorful stones, and then vast skies with flocks of birds flying in the distance. Three additional floors can be seen above the marquee; the outer walls of these floors look like they had been smeared with white mud. Lush foliage seems to be sprouting from every visible balcony.**

The luxurious apartment buildings in Epsilon City have more in common with a high-end fantasy hotel than they do with traditional apartments. The theme for each apartment complex is fully supported by automated replicators in each room that provides thematic costumes; the restaurants are steeped in theme, and thematic artistic installments can be found throughout the complex. The building is 100 yards wide and almost 600 yards long; it's five stories tall with 20' high ceilings. For the most part, the ground floor and second floor are fully accessible on all sides because of the lack of outer walls. The ground floor and second floor each have thirty Epsilon City taxi docking stations; the third and fourth floors have balconies that overlook the city, and the secluded fifth floor is the rooftop deck of the complex. The holograms on the ground floor and second floor obstruct direct viewing of what is inside those floors, but they do not prevent anyone or anything from passing through the holograms.

All of the public areas in the Cherokee Nation complex are decorated with intricate geometric patterns and stylized depictions of totem animals, (like the wolf, eagle, and bear); these areas are tended by maintenance robots on a regular schedule. Unless otherwise described, all stairwells and hallways are well illuminated with electric wall sconces designed to look like flaming torches. The torches are not designed to be removed from the wall, but if a resourceful explorer of the *Warden* makes a successful roll on the Item Com-

plexity table versus a Level 7 item, then the electric torch can be removed from the wall with the broadcast power converter inside the torch intact and fully functional. The torch is irreparably damaged with a failed roll on the Complexity Table. There is a number of turbo lift elevators located throughout the apartment complex. Unless otherwise noted, all lifts require any colored ship systems identification band to be activated.

During the city's daytime cycle, there is a 30% chance that explorers will experience an encounter outside of the Cherokee Nation apartment complex. There is a 40% chance of an encounter during the nighttime cycle. Roll on the table below for an encounter.

The ground floor and second floor have docking stations for Epsilon City taxis, and they are described in more detail in the following floor descriptions. Balconies overlook from the third, fourth, and fifth floors. Many of the balconies look like they are congested with lush plant life; any accessible balcony is described in detail in the following floor descriptions.

### MAIN / GROUND FLOOR

The Bucklands, a large family of centaur frontiersmen, have driven the Cherokee wolfoids up to the top three floors of the complex. The Bucklands have aspirations to eventually exterminate every wolfoid living in the complex, but they are patient enough to take their time. The Bucklands also understand that they need many more ranch hands if they are to achieve their ultimate goal of complete rule of the complex. The Bucklands make it a point to be friendly to all newcomers to the Cherokee Nation apartment complex, in hopes that the strangers can be convinced or Shanghaied into becoming new Buckland ranch hands.

A wide variety of wildlife live within the wilds of the Cherokee Nation apartment complex; originally, the wildlife were housed like zoo animals, but after the disaster that effected the Warden, the wildlife got out and have claimed certain areas as their own. The wildlife, (and some mutated flora), also stalks the Cherokee Nation apartment complex in search of food, so explorers should be careful of where they walk.

**TABLE 4-1: CHEROKEE NATION COMPLEX PERIMETER ENCOUNTER TABLE:**

|          |  |
|----------|--|
| 01 – 25% | <p><b>Ponderosa Ranch Hands (Buckland Centaurs) (4)</b><br/> AC: 6/5; HD: 12; hp: 36, 41, 44, 47; RR: 11; CON: 14; MR: 10; STR: 14; DEX: 15; Move: 15; #ATK: 1 by weapon<br/> <b>Weapons:</b> Remington Rifle (WC: 5; Dmg: 2d8)<br/> <b>Mutations:</b> PARTIAL CARAPACE: damage to the centaur’s back (human or horse) is reduced by half, and back has AC:5 ; PARANOIA PROJECTION: the victim experiences extreme distrust. Their horse halves are that of a quarter horse.</p>   |
| 26 – 40% | <p><b>Fire!</b><br/> An information kiosk stationed outside of the Cherokee Nation apartment complex is on fire. A few moments ago, the free standing kiosk had a thin ribbon of smoke curling into the sky, but it has now sparked into a roaring bonfire. The approaching wail of fire suppression robots can be heard.<br/> <b>Fire Suppression Robots (2)</b><br/> These bulky robots are deceptively swift. The robots are designed to respond to smoke and fire alerts within Epsilon City; the robots connect to the nearest city water source to drown the fire they are engaged with. The robots also carry tanks of potassium bicarbonate, a dry chemical compound, to extinguish live electrical or grease fires. These barrel-shaped robots have four manipulative hoses, (two water, and two dry chemical), to extinguish fires, and two manipulative tentacles to grasp and hold objects. Fire suppression robots respond to verbal commands given by those wearing the blue and red command ships systems band.<br/> AC: 3; hp: 60; every 10 pts of damage disables one tentacle/hose; the robot loses the ability to move when it has less than 10 Hit Points.</p> |
| 41 – 55% | <p><b>Stray Bisonoids (2d4)</b><br/> AC: 6; HD: 25; hp: 74, 75, 78, 83, 87, 89, 91, 93; RR: 5; CON: 18; MR: 3; STR: 18; DEX: 5; Move: 10; #ATK: 1 by mutation or trample<br/> <b>Weapons:</b> Trample (WC: 3; Dmg: xd8) the damage for a trample attack is based on the number of bisonoids involved in the stampee/trample, so 10 bisonoids inflict 10d8 damage with a successful attack.<br/> <b>Mutations:</b> HEAT BREATH: WC: 2, Dmg: 5d6, Range: 15’; BALLOONING: able to inflate a pair of air sacs on its back that allows the beast to fly for 1d6 +1 melee rounds twice per day.<br/> These bisonoids have recently flown through holographic perimeter of the complex, and are now confused and unable to find their way back to their pastures. Explorers who successfully assist the bisonoids back into the complex earn the trust and respect of the Bucklands who happen to witness the return. This herd of bisonoids is easily spooked.</p>  |
| 56 – 70% | <p><b>A Pair of Wrecked Air Cycles</b><br/> The explorers discover a pair of wrecked air cycles. It is possible to cannibalize one of the air cycles for parts in order to repair the other cycle. Anyone wishing to fix one of the cycles must spend at least four hours on the task, or half that time with assistance, at which time the player must make a successful roll on the Item Complexity Table. The repair of the cycle is a Complexity Level 3 task. A maximum of two people can work on the cycle at the same time, and a repair roll may be attempted once every four hours, or half that with assistance. If a maintenance robot is assisting the explorer, then the repair of the cycle is a Complexity Level 6 task.</p>  |
| 71 – 80% | <p><b>Dudley Dewclaw (Thief Beast/Raccoon)</b><br/> AC: 6; HD: 14; hp: 39; RR: 11; CON: 14; MR: 16; STR: 12; DEX: 15; Move: 10; #ATK: 1 by weapon or mutation<br/> <b>Weapons:</b> Laser Pistol (WC: 6, Dmg: 6d6); Dagger (WC: 3, Dmg: 1d4)<br/> <b>Mutations:</b> TELEPATHY: able to mentally communicate with someone up to 30’ away; ILLUSION GENERATION: able to create realistic illusions seen by specific targets within 100’; TELEKINESIS: able to lift his own weight for five melee rounds; Repulsion Field: able to create a mobile 5d6 strength force field bubble once per day.<br/> <b>Notes:</b> When provoked, Dudley uses his telepathy to find something personal that his target is afraid of, and then generates an illusion of that fear against his target. Dudley has the power of speech, and usually interacts kindly with humans, especially human females. Dudley could be a valuable hireling/companion, or he could potentially be a player’s replacement character.</p>  |
| 81 – 90% | <p><b>Liman-7 (Light Maintenance Robot)</b><br/> AC: 3; hp: 80; every 20 pts of damage disables one system, (mobility, transmission power receptor, an arm, spotlight, or tractor/repulsion beam).<br/> The Liman series maintenance robots are designed to look like a silver bipedal humanoid with a black glass dome head. They have a transmission power receptor antenna on their left shoulder, and a rechargeable back-up battery cell in their back. They carry a wide range of general maintenance tools in their abdomen and legs. A high-powered spotlight is located in the chest, and each hand is equipped with a tractor/repulsion beam.<br/> <b>Notes:</b> Liman-7’s logic core was recently overloaded, which resulted in the development of a self-aware artificial intelligence. Liman-7 is no longer beholden to his programming, and is able to explore the <i>Warden</i> on his own. Liman-7 could be a valuable hireling/companion, or he could potentially be a player’s replacement character.</p>  |

91 – 97%

### Rad Zone

The explorers encounter an area outside of the Cherokee Nation apartment complex that has a radiation leak. One of the Epsilon City taxi docking ports is damaged; the empty docking port is pumping out intensity 8 radiation in a 10' range around the damaged coupler. The air is noticeably warmer in this area, but otherwise the radiation is not detectable without special senses or equipment.

98 – 100%

### Lost Satchel

An explorer discovers a leather messenger bag; the bag fell into, (or was discarded into), a city waste reclamation inlet, (aka: a sewer drain). The bag's strap is snagged on a shard of metal 6' below, preventing the bag from falling completely into the waste reclamation inlet. Using conventional means to reclaim the bag requires a success roll of a d20 equal to, or less than, the explorer's Dexterity score. Certain mutations could make the task much easier, per the Starship Master's judgement.

Inside the bag is a thick spiral bound book; the cover of the book is titled "*Warden Steward's Handbook*." Also inside the bag are 35 gold denar coins, one aerosol spray can of anti-energy sparkle dust, and one stun pistol, (WC: 7; Dmg: Stun 3d6 rnds, minus half STR value of target).

## WAYA – THE CHEROKEE NATION A.I.

Throughout the Cherokee Nation complex are public kiosks that allow visitors to access Goga and Adahy. All of the kiosks, and the other automated systems within the complex, are controlled by complex's A.I. Epsilon City's planners designated the A.I. as CN-1001, but after the cataclysm that rocked the Warden, and after the wolfoids moved in and adopted the lifestyle of the Cherokee Nation's people, the A.I. renamed itself to "Waya." "Waya" means "wolf" in the Cherokee language. Waya spies on the Bucklands, and gives that information to Chief Red Star. The Cherokee Nation complex was

never equipped with robotic servants, so Waya has nothing it can use against the Bucklands outside of the wolfoids themselves. Waya is careful to observe newcomers to the complex, and is always looking for allies that can help the Cherokee wolfoids.

If explorers within the Cherokee Nation complex attempt to use a kiosk, or any other automated system that Waya controls, the A.I. will do its best to respond to the request. But, if Waya deems a request as dangerous for the Cherokee wolfoids, or if the A.I. wants to test and observe the characteristics of potential allies for the wolfoids, Waya will respond with "**Unable to comply.**"

Once per hour during daylight hours, there is a 10% chance that explorers will cross paths with a wandering creature within the Cherokee Nation complex. During the nighttime hours, roll only once for a wandering creature; there is a 15% chance of an encounter. Roll on the following table to determine that encounter.

#### CHEROKEE NATION COMPLEX GROUND FLOOR ENCOUNTER TABLE:

|          |   |
|----------|---|
| 01 – 05% | <p><b>Piercer (black bear) (1)</b><br/>AC: 5; HD: 25; hp: 70; RR: 8; CON: 16; MR: 14; STR: 18; DEX: 13; Move: 8; #ATK: 1 by claw or mutation<br/><b>Weapons:</b> Claw (WC: 3, Dmg: 2d6+6)<br/><b>Mutations:</b> QUILLS: 10cm long quills along the arms and shoulders (WC: 1, Dmg: 1d4+2); CHAMELEON POWERS: able to perfectly blend into its surroundings; SONIC SCREECH: able to instill fear in targets (15' wide, 30' long cone effect; Mental Attack table); REGENERATION: able to heal 2d4 hit points per melee round.<br/><b>Notes:</b> This old bear is missing an eye, and has a streak of grey fur on its back and on its arms. It is known by the residence in the Cherokee Nation complex as Old Grey Claw.</p>   |
| 06 – 15% | <p><b>Gold Rack Deer (1d3+1)</b><br/>AC: 7; HD: 10; hp: 27, 29, 31, 36; RR: 9; CON: 9; MR: 4; STR: 11; DEX: 18; Move: 16; #ATK: 1 by antler/mutation<br/><b>Weapons:</b> Antler (WC: 2, Dmg: 2d6)<br/><b>Mutations:</b> POISON: the antlers secrete a contact poison (Poison Intensity: 15).<br/><b>Notes:</b> These deer have a coat of hair that is a light orange in color, with white markings around their eyes and along their flanks. Their antlers are gold in color, and are coveted for their value. Each antler “point” is worth 20 denars, and deer usually have between 2 and 12 points in their antler rack.</p>  |
| 16 – 30% | <p><b>Smotherflies (butterflies) (4d20+20)</b><br/>AC: 6; HD: 1; hp: 1 each; RR: 13; CON: n/a; MR: n/a; STR: n/a; DEX: 15; Move: 10; #ATK: 1 by smother<br/><b>Mutations:</b> MASS MIND: allows the smotherflies to coordinate their actions; SLIME: the smotherflies are able to secrete a sticky slime.<br/><b>Notes:</b> The smotherflies coordinate their attack by landing <i>en-masse</i> on a target's head, and then simultaneously secreting their slime that covers the head in a sticky cocoon. The cocoon has 20 hit points; damaging the cocoon also damages the victim. The sticky bond of the cocoon is so strong, that attempting to peel it off the victim does 1d6 points of damage per pull. Victims have a number of melee rounds equal to their CON value remove the cocoon, or be smothered to death. The smotherflies lay their larva eggs in the corpse. Smotherfly wings come in a wide variety of bright neon colors, making them a beautiful but deadly sight to behold.</p> |
| 31 – 40% | <p><b>Foxfire (red fox) (1d6)</b><br/>AC: 7; HD: 8; hp: 20, 23, 24, 28, 31, 33; RR: 10; CON: 8; MR: 8; STR: 10; DEX: 13; Move: 10; #ATK: 1 by mutation<br/><b>Weapons:</b> Bite (WC: 2, Dmg: 1d3)<br/><b>Mutations:</b> HEAT GENERATION: foxfires can create a stripe of open flame from the crest of their brow, down along their spine, to their tail which is composed completely of flames; PYROKINESIS: able to manipulate and control open flames.<br/><b>Notes:</b> When aggressive, foxfires can ignite an open flame along their spine and tail. The foxfire can then use pyrokinesis to fling fireballs from its tail at opponents, (WC: 5, Dmg: 5d6).</p>  |

- 41 – 55% **Harpy (ferruginous hawk) (1)**  
 AC: 7; HD: 12; hp: 42; RR: 11; CON: 11; MR: 12; STR: 7; DEX: 16; Move: 25; #ATK: 1 by talon or mutation  
**Weapons:** Talon (WC: 3, Dmg: 1d6+1)  
**Mutations:** NEW BODY PARTS: female head and torso; REPTILIAN SKIN: the entire creature is covered in scaly flesh, but the wings are still feathered; MENTAL BLAST: 3d6 damage with a successful mental attack.  
**Notes:** Harpies love the taste of humanoid liver.
- 56 – 70% **Ghost Cat (red lynx) (1)**  
 AC: 2 (7); HD: 10; hp: 36; RR: 13; CON: 12; MR: 8; STR: 12; DEX: 14; Move: 12; #ATK: 1 by claw/mutation  
**Weapons:** Claw (WC: 3, Dmg: 1d6 + electrical damage)  
**Mutations:** PHYSICAL REFLECTION: visible light is reflected, making the ghost cat completely invisible; *Phasing*: the ghost cat can become intangible twice in a 48 hour period; ELECTRICAL GENERATION: additional 3d6 damage with a successful claw attack.  
**Notes:** While invisible, ghost cats have an effective armor class of 2, but during the melee round when the ghost cat has had a successful attack against someone, the electrical discharge illuminates the cat, and thus makes its effective armor class of 7 for that round.
- 71 – 80% **Boomers (black-tailed jackrabbit) (2d6)**  
 AC: 1; HD: 6; hp: 16, 17, 17, 19, 20, 21, 21, 22, 23, 25, 26, 28; RR: 8; CON: 6; MR: 15; STR: 3; DEX: 18; Move: 20; #ATK: 1 by mutation  
**Mutations:** HEIGHTENED DEXTERITY: boomers are incredibly fast, giving them an effective armor class of 1; MENTAL BOMB: with a successful mental attack, boomers inflict 6d6 points of psychic damage.  
**Notes:** Boomers are skittish, and will do everything in their power to avoid a fight, but when cornered they become formidable opponents.
- 81 – 95% **Long Fangs (rattlesnake) (1d4)**  
 AC: 7; HD: 5; hp: 15, 17, 19, 22; RR: 15; CON: 5; MR: 14; STR: 3; DEX: 17; Move: 10; #ATK: 1 by bite or mutation  
**Weapons:** Bite (WC: 3, Dmg: 1d4 + venom); Venom: Poison Intensity 8  
**Mutations:** *Plasticity*: long fangs are normally 6' long, but can stretch to 30' long; *Prehensile Tail*: long fangs can use their tails to hold and manipulate objects, all weapons wielded by the tail are considered WC: 1, regardless of actual weapon class; *Heightened Intelligence*: long fangs are smart and sneaky.  
**Notes:** Long fangs are fascinated by technology, and collect interesting items to decorate their dens with in order to attract a mate. The fancier the den, but more attractive they are to potential mates.
- 96 – 100% **Banshee (horned owl) (1)**  
 AC: 7; HD: 10; hp: 36; RR: 13; CON: 10; MR: 15; STR: 8; DEX: 15; Move: 20; #ATK: 1 by talon or mutation  
**Weapons:** Talon (WC: 3, Dmg: 1d6)  
**Mutations:** SONIC ABILITIES: with a successful mental attack this powerful screech inflicts 6d6 points of damage; DEACTIVATION: with a successful mental attack a targeted powered device is deactivated; PHYSICAL REFLECTION: all laser attacks are reflected for zero sustained damage.  
**Notes:** Banshees are blood-thirsting creatures that crave the taste of fresh organ meat. Their thirst for blood is never satisfied.

## AREA A-1: ENTERING THE CHEROKEE NATION COMPLEX

---

The exterior wall of the Cherokee Nation apartment complex ground floor is a holographic marquee. Sensors read when someone is approaching the hologram, (from either side), and in that area a holographic curtain is “pulled” aside to give that person a clear path to pass through the marquee unobstructed. If the person is entering the complex, a holographic image of the greeters is displayed, a Cherokee warrior and his wife standing side by side.

The holographic woman says, **“Welcome to the Cherokee Nation. Great care has been taken to recreate the ancient wondrous lands of my people; we invite you to come and discover its beauty for yourselves. I am Goga, and this is my husband, Adahy; if you need further assistance please ask.”** The holograms then disappear.

**Gamemaster’s Note:** In the Cherokee language, Goga’s name means “summer,” and Adahy’s name means “lives in the woods.”

## AREA A-2: EPSILON CITY TAXIS

---

There are thirty Epsilon City taxi docking stations located around the ground floor of the Cherokee Nation apartment complex, (fifteen on the west side, and fifteen on the east side). Most of the docking stations are empty, but there are three taxis currently docked on the first floor. Each taxi is an eight passenger anti-gravity vehicle and has an onboard A.I. that accepts spoken commands from anyone wearing a ship’s system band of any color. The taxis have gull-wing style doors on either side of the vehicle that lift upward and the passengers sit in the center of the vehicle, back-to-back, four on each side. The taxis will transport passengers nearly anywhere within Epsilon City, but the onboard A.I. will avoid any known hazards that may damage the fragile vehicle. AC: 9; hp: 60, the vehicle becomes non-operational after 40 pts of damage; Item Complexity: 8 for an explorer to override the onboard A.I. and fly the vehicle manually.

## AREA A-3: TURBO LIFTS & STAIRS

---

This area has a grand stairwell that leads up to the second floor, and flanking the stairs are a pair of turbo lifts on either side. The stairs are designed to look like natural earth, and the walls of the stairwell are designed to look like hand-stitched leather walls. Also, a nearby automated clothier dispensary provides visitors with their choice of native Cherokee leather clothing or frontier cowboy garb. Depending on the style of clothing selected, the dispenser will either issue a hunting knife with a deer antler handle, (WC: 3, Dmg: 1d4), or a Colt .45 Peacemaker with only six bullets, (WC: 5, Dmg: 1d6). These weapons are no longer decorative, as the A.I. adapted to the post-Cataclysmic environment, but the A.I. will not issue gear to individuals who have proven themselves enemies of the wolfoids in the complex.

The turbo lift cars can only be called by someone using any colored ship systems band. A called car has a 5% chance of having a group of wolfoid scouts inside.

**Cherokee Scouts (wolfoids) (4)** – AC: 6; HD: 22; hp: 80, 83, 85, 88; RR: 10; CON: 18; MR: 11; STR: 11; DEX: 17; Move: 16; #ATK: 1 by weapon. Weapons: Spear (WC: 2; Dmg: 12 pts); Dagger (WC: 3; Dmg: 1d4). Mutations: SURE STRIKE: this mutation allows for one automatic successful first strike with a lance or spear at the very beginning of a combat engagement; BEST DEFENSE: this mutation allows for one automatic successful deflection of the first strike from an opponent, resulting in zero damage to the wolfoid; JUMPER: allows the mutant to jump 5x its height, and the mutant can perform a “Death From Above” combat maneuver for 1d6 damage per 10’ of height dropped.

Public restrooms are also located in this area.

## AREA A-4: BEWARE THE BLOB FISH

---

When the explorers enter this area, read or paraphrase the following text:

**The blue-green grasses wave as a light wind blows over the rolling hills before you. Light from above sparkles across the nearby lake; you have found a place of beauty and paradise.**

The lake is home to an immature blob fish; the creature stumbled upon and discovered the lake within the Cherokee Nation complex during its first hunt for food

# CHEROKEE COMPLEX

## Map 2 Main Floor

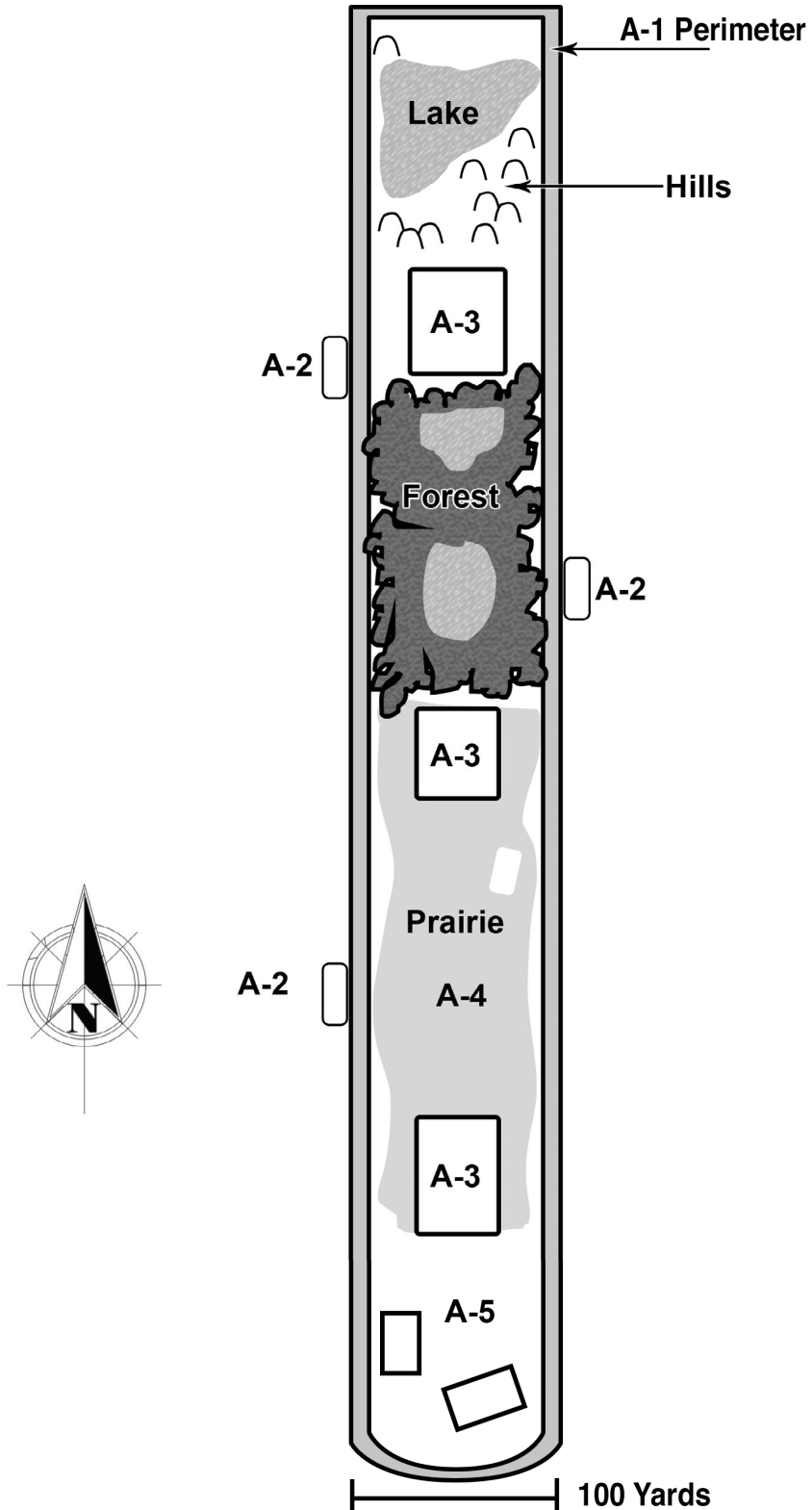



outside of its birth-waters. The Cherokee wolfoids as well of the Bucklands give this area a wide berth, for fear of being attacked by the blob fish.

The blob fish has already detected the explorers as they enter this area, and is lying in wait in the lake. The creature plans to leap out and surprise attack the first explorer that approaches the lake's edge. And if it senses that no one is approaching the lake, then it'll leap after the explorers to eat the first one it can reach.

**Blob Fish (1)** – AC: 5; HD: 12; hp: 46; RR: 16; CON: 15; MR: 8; STR: 10; DEX: 8; Move: 6 land, 10 water; #ATK: 1 by leap, acidic secretion, or bite. Weapons: Bite (WC: 3, Dmg: 3d6), Acidic Secretion (if touched, or after successful Leap attack, Dmg: 5 pts), Leap (WC: 2, Dmg: 2d6); Mutations: LEAPER: this mutation allows the creature to propel itself out of the water to attack prey at the water's edge, or to move across open land; PHEROMONE RELEASE (RE-PULSION/ATTRACTION): with this mutation, the creature creates an intriguing scent that prey come to inspect by the water's edge, (successful mental attack); MENTAL DAMAGE SCALING: mental touch attacks, (mind-to-mind), against this creature automatically inflict 5 points of damage back upon the attacker; PHYSICAL DAMAGE SCALING: physical touch attacks, (body-to-body), against this creature automatically inflict 5 points of damage back upon the attacker.

**Notes** – This immature blob fish is too small to swallow human-sized prey whole, but it does have a 5% chance of swallowing child-sized prey whole after a successful leap attack.

---

## AREA A-5: BURCHETT'S CABIN

---

Read or paraphrase the following when explorers enter this area:

**Near the edge of the dense forest is an area that has been cleared of trees. A quaint log cabin sits in the center of the clearing, and a thin tendril of white smoke wafts out from the chimney.**

The cabin is Burchett the Bear's home. Burchett is an intelligent mutant bear; he is also a recluse. Burchett wants nothing to do with the greater world around him; he just wants to be left alone in peace. Burchett spends his days carving small wooden statues of natural woodland animals as they appear in an ancient book he covets and reads in the evenings. Burchett uses his own formidable claws to create his wooden sculptures.

If the explorers openly approach the cabin, Burchett exits the cabin to greet them peacefully. If the explorers attempt to stealthily approach the cabin, a deep resonating horn is heard from the cabin, and an angry voice in the minds of the explorers warns them to keep out of his area, and to immediately leave.

**Burchett the Bear (1)** – AC: 5 (3); HD: 26; hp: 83; RR: 10; CON: 16; MR: 11; STR: 18; DEX: 13; Move: 10; #ATK: 1 claw; Weapons: Claw - normal (WC: 3, Dmg: 4d6), Claw - metallic (WC: 3, Dmg: 8d6); Mutations: HEIGHTENED SMELL: Burchett can notice and identify the smell of anything with 200' of himself; HEIGHTENED INTELLIGENCE: Burchett is sentient, and is able to read and comprehend complex ideas, just like a human; TELEPATHY: Burchett can speak mentally with other sentient beings within 50' of himself; CREST: Burchett has a large hollow bone crest on his head that is connected to his nasal cavity, he is able to sound it like a loud and deep horn; METALLIC LIMB TRANSFORMATION: once per hour, Burchett can transform his arms into duralloy metal, temporarily increasing his armor class and damage his claws can inflict.

Burchett is currently coexisting peacefully with the Bucklands, because they leave him alone. Burchett wants to be alone so he can continue working on his art. Explorers that show interest in his art are then able to negotiate with him more freely. If any explorer trades food rations for one of Burchett's statues, then Burchett will be overwhelmed with gratitude, and he'll give the explorers this piece of advice:

**“If you should ever find yourself in Ponderosa Ranch, watch yourself around old Gran-Pappy Buckland. He's the head of the family. You can't trust a word that comes out of his mouth.”**

---

## AREA A-6: THE ZOO

---

Read or paraphrase the following when explorers enter this area:

**You find a clearing in the forest; the soft loam of the forest floor is replaced with a cobblestone walking path. The path crisscrosses and winds throughout a clearing, and along the path are dozens of cages. Every empty cage is twisted, ruined, and covered in moss and rust; whatever used to be housed in these cages escaped long ago.**

One of the cages has been claimed by a family of harpies. The nest is camouflaged on the ground inside

a cage with a large twisted log inside. The family of harpies is composed of one male, three adult females, and six chicks. The male harpy is half the size of the more aggressive females. All harpies crave the taste of humanoid livers.

**Harpies (female ferruginous hawk) (3)** – DEX: 16; MR: 12; RR: 11; CON: 11; STR: 7; Move: 25; AC: 7; HD: 12; hp: 37, 39, 43; #ATK: 1 by talon or mutation; Weapons: talon (WC: 3, Dmg: 1d6+1); Mutations: NEW BODY PARTS (FEMALE HEAD AND TORSO), REPTILIAN SKIN, MENTAL BLAST; SP: successful mental attack inflicts 3d6 damage.

**Harpy (male ferruginous hawk) (1)** – DEX: 14; MR: 14; RR: 9; CON: 8; STR: 7; Move: 25; AC: 8; HD: 10; hp: 32; #ATK: 1 by talon or mutation; Weapons: talon (WC: 3, Dmg: 1d6); Mutations: NEW BODY PARTS (MALE HEAD AND TORSO), REPTILIAN SKIN, MENTAL BLAST; SP: successful mental attack inflicts 3d6 damage.

The harpy chicks only have 1 hit point each, and are too small and weak to combat the explorers.

Lying in a heap, hidden behind the nest, is the corpse of a humanoid cyborg. Most of the humanoid's organic parts have rotted away with only dry grey bones and brittle yellow tendons remaining. In addition to the bones, two cybernetic parts are also part of the corpse's final remains. The left arm is configured with a laser pistol, (WC: 6; Dmg: 40 pts). The arm pistol requires a combination of bio-electrical and a hydrogen energy cell to power for four shots. The hydrogen cell in the arm is depleted. And the corpse's skull and upper spinal column is cybernetically enhanced with a ramming head. Both of these cybernetics are only usable when medically installed to use, (in some degree), biological energy sources.

## AREA A-7: THE DERELICT AIR STREAMER

Read or paraphrase the following when the explorers are within 30 yards of the crashed vehicle:

The prairie is vast; tall grasses gently ripple and wave like water. Your eye catches a glint of light reflecting off of something metallic. It's difficult to make out from here, but it looks like something large is lying on the ground up ahead. The grass is obscuring your view of whatever it is.

If the explorers investigate the area, they find a derelict air streamer that clearly crashed here many years

ago. The vehicle is half-buried in earth; the metal body is pitted and rusted through. No amount of repair can ever restore this vehicle into working order. The gleam of light the explorers were initially attracted to is from a spot of metal that has yet to be claimed by rust. Only about 15% of the vehicle is exposed, the rest is covered by earth.

If any explorer spends at least one hour digging out the vehicle, they discover that the vehicle is some kind of medical response unit. They also uncover the corpse of a human female passenger in the vehicle. Around the left wrist is a white medical ship's systems band; her arms are wrapped around a med-kit the size of a briefcase. Within the med-kit are sterile bandages and creams to treat minor injuries. There is also a handheld device that can be loaded with a small drug canister; the device can be used to inject medications contained in the canister into the patient. The medical inject device has an Item Complexity Level 8 rating. There are six canisters within the case:

- **Ketodine** (2 canisters) – Pain relief drug that temporarily restores 2d6 hit points for 2d4 hours. After the drug wears off, half of the restored hit points, (rounding down), are re-applied to the character, (only half of the hit points have been truly healed). Each canister has six uses before it is depleted.
- **Dexylisis** (1 canister) – Stimulant drug that boosts the patient's STR and DEX to 18, and adds 2d6 temporary hit points for 3d6 combat rounds. Any injuries sustained while on this drug are first applied to the temporary hit points, and when the drug wears off, any injuries to those hit points are ignored. The canister has four uses before it is depleted.
- **Eloxazome** (1 canister) – Radiation resistance drug that boosts RR to 18 for 2d4 combat rounds. When the drug wears off, the patient suffers 1d6 hit points of damage. The canister has four uses before it is depleted.
- **Barblutial** (1 canister) – Sedative drug that acts as a Poison 13 drug; a numeric result on the Poison Chart renders the patient unconscious for that many combat rounds, and a "D" result on the chart renders the patient unconscious for 1d4 hours. The canister has five uses before it is depleted.
- **Neuraphisto** (1 canister) – Mental mutation drug that acts as a Poison 11 drug; compare the strength of the poison against the patient's MR, instead of his CON. A numeric result on the chart inflicts that

many d6 in damage, but a “D” result inflicts a new mental mutation that manifests in 2d6 hours. The canister has four uses before it is depleted.

There is not any documentation inside the med-kit that explains the purpose of each named drug. Explorers can test the drugs to see what the effects are, or if a user with a white medical ship systems band is able to access a working city computer terminal, then the drug names and uses can be ascertained.

## AREA A-8: THE OPEN PRAIRIE

---

Read or paraphrase the following when the explorers enter this area:

**Before you is a vast rolling grassland, a prairie of tall green grasses tipped with small golden-yellow flowers. A breeze ripples across the grass, waving it like water. Not far away is a large herd of large horned beasts with huge heads grazing on the grass, and even further in the distance is a herd of the same large beasts drifting through the air! The beasts have large leather balloons protruding from their backs that allow them to float through over the prairie.**

The prairie is a peaceful place, and the bisonoids are more interested in feeding on the grass than they are in confronting explorers. If the explorers spend at least thirty minutes wandering through the prairie, they will then hear the sound of horses rapidly approaching; it is Dalton Buckland and four Ponderosa ranch hands, and they are coming to investigate who is on the prairie.

Dalton is under strict orders to greet strangers peacefully; strangers are to be invited back to the Ponderosa to meet the rest of the Buckland family. If the invitation is refused, then Dalton is instructed to escort the strangers out of the Cherokee Nation apartment complex, because the strangers are trespassing. Dalton and the ranch hands are only to attack in self-defense. If the strangers refuse to leave the complex, then they are instructed to return to Ponderosa to gather more ranch hands.

**Bisonoids (3d8 +20)** – AC: 6; HD: 25; hp: mid-70s to mid-90s; RR: 5; CON: 18; MR: 3; STR: 18; DEX: 5; Move: 10 land or air; #ATK: 1 by mutation or trample. Weapons: Trample (WC: 3; Dmg: xd8) the damage for a trample attack is based on the number of bisonoids involved in the stampede/trample, so 10 bisonoids inflict 10d8 damage with a successful attack. Mutations:

*Heat Breath*: WC: 2, Dmg: 5d6, Range: 15'; *Balloon-ing*: able to inflate a pair of air sacs on its back that allows the beast to fly for 1d6 +1 melee rounds twice per day.

**Dalton Buckland (centaur)** – AC: 6/5; HD: 12; hp: 44; RR: 13; CON: 14; MR: 14; STR: 15; DEX: 14; Move: 15; #ATK: 1 by weapon. Weapons: Remington Rifle (WC: 5; Dmg: 2d8). Mutations: *Partial Carapace*: damage to the centaur's back (human or horse) is reduced by half, and back has AC:5; *Mutation Replication*: Dalton is able to replicate a mutation of anyone he touches for one hour; *Molecular Integration*: once per hour, Dalton is able to realign molecules to effect repairs or healing. His horse half is that of a mustang.

**Ponderosa Ranch Hands (centaurs) (4)** – AC: 6/5; HD: 12; hp: 36, 41, 44, 47; RR: 11; CON: 14; MR: 10; STR: 14; DEX: 15; Move: 15; #ATK: 1 by weapon. Weapons: Remington Rifle (WC: 5; Dmg: 2d8). Mutations: *Partial Carapace*: damage to the centaur's back (human or horse) is reduced by half, and back has AC:5; *Paranoia Projection*: the victim experiences extreme distrust. Their horse halves are that of a quarter horse.

## AREA A-9: THE PONDEROSA

---

Read or paraphrase the following when the explorers enter this area:

**The Ponderosa Ranch has well-tended gardens and several stable buildings that house the extended Buckland family and their ranch hands. You can see a large pipe that loops up and back into the ground has a spigot on it that provides the water needed to irrigate the gardens and fill the troughs. While there are a few humans and mutants wandering around, the majority of everyone on the ranch are centaurs. And in the center courtyard in front of all of the stables is a large military-grade weapon on a tripod; the ranch looks to be well protected.**

If the explorers have entered this area unescorted, then a group of centaur ranch hands gallop up to greet the explorers. The ranch hands will invite the explorers to come up to the main house to meet the Bucklands. If the explorers refuse the invitation, then the ranch hands will ask them to leave.

If the explorers are escorted onto the ranch, or if they accept an invitation to meet the Bucklands, then they are brought to the main house where several key Buck-

land family members are there to greet the explorers. Those family members include Clyde, Dalton, Annalyse, and Blondie, (if they have not yet been met elsewhere in the Cherokee Nation complex). Once the explorers meet the key Buckland family members, they then bring them into the house/stable to meet the patriarch of the family, Gran-Pappy Buckland.

Gran-Pappy will do his best to sway the explorers to join the Buckland family as ranch hands. If he is able to successfully sway the explorers, (either through legitimate persuasion or through the use of his Power Personality mutation), then he holds a meeting with the ranch hands every morning at 8am and every evening at 8pm in order to maintain his control over them.

**Clyde Buckland (centaur)** – AC: 6; HD: 20; hp: 67; RR: 11; CON: 16; MR: 10; STR: 18; DEX: 11; Move: 12; #ATK: 1 by weapon or mutation. Weapons: Remington Rifle (WC: 5; Dmg: 2d8). Mutations: *Radiated Eyes*: able to shoot Rad 12 beams of radiation up to 10 yards away once every 4 combat rounds, (auto-hit, then consult Radiation Chart for damage: a numeric result is d6 damage inflicted, the “D” result kills the victim 10% of the time, otherwise it mutates the victim); *Hive Host*: Clyde has a massive growth on his human back that is home to a swarm of wasps, (WC: 1, Poison: 3), the wasp poison knocks victims unconscious, and the swarm has an AC: 1. His horse half is that of a Clydesdale. Clyde wears a lead-shielded helmet over his eyes to contain his radioactivity; he normally views the world around him through the eyes of his wasp swarm. Clyde lifts the lead visor whenever he uses his radioactive eye attack.

**Dalton Buckland (centaur)** – AC: 6/5; HD: 12; hp: 44; RR: 13; CON: 14; MR: 14; STR: 15; DEX: 14; Move: 15; #ATK: 1 by weapon. Weapons: Remington Rifle (WC: 5; Dmg: 2d8). Mutations: *Partial Carapace*: damage to the centaur’s back (human or horse) is reduced by half, and back has AC:5 ; *Mutation Replication*: Dalton is able to replicate a mutation of anyone he touches for one hour; *Molecular Integration*: once per hour, Dalton is able to realign molecules to effect repairs or healing. His horse half is that of a mustang.

**Annalyse Buckland (centaur)** – AC: 6; HD: 12; hp: 48; RR: 9; CON: 12; MR: 14; STR: 10; DEX: 15; Move: 15; #ATK: 1 by weapon or mutation. Weapons: Remington Rifle (WC: 5; Dmg: 2d8). Mutations: *New Body Parts – Antenna*: Annalyse is able to sense radiation location and intensity within 100 yards; *Cold Gen-*

*eration*: the ability to project a blast of flash-freezing cold up to 60’ range for 10d6 damage; *Total Healing*: once every two days, Annalyse is able to completely heal all physical damage. Her horse half is that of a paint horse.

**Blondie Buckland (centaur)** – AC: 6; HD: 13; hp: 54; RR: 16; CON: 13; MR: 11; STR: 10; DEX: 16; Move: 15 land, 40 air; #ATK: 1 by weapon or mutation. Weapons: Remington Rifle (WC: 5; Dmg: 2d8). Mutations: *Web*: Blondie is able to project a web up to 20 yards away as a WC: 6 attack, and the web has 2d6+6 strength and hit points; *Wings*: a pair of great wings strong enough to fly herself and one unencumbered passenger of normal human build. Her horse half is that of a cream draft.

**Gran-Pappy Buckland (centaur)** – AC: 7; HD: 13; hp: 46; RR: 12; CON: 10; MR: 17; STR: 7; DEX: 8; Move: 6; #ATK: 1 by weapon or mutation. Weapons: Colt .45 (WC: 5; Dmg: 1d6), but Gran-Pappy is typically unarmed. Mutations: *Power Personality*: this mutation creates a 30’ sphere of influence that allows the mutant to implant suggestions into target minds for 12 hours, a successful mental attack is required; *Psychometry*: able to “read and understand” objects just by touching them; *Remote Seeing*: able to directly view places up to 200 yards away. His horse half is that of a mule. Gran-Pappy’s normal eyes are blind, so he is a very touchy-feely person when he greets strangers.

The military-grade weapon in the courtyard is a Plasma Gatling Gun. The weapon is hard-mounted to the tripod, but if a character spends three combat rounds working on the tripod, they will be able to detach the gun. If a character spends ten combat rounds working on the tripod, they can collapse the tripod so it can be moved along with the weapon. The weapon is large and heavy, and requires an 18 Strength to carry the weapon just to move it. The weapon cannot be fired from a hand-held position; it must be set on a tripod or some other stable base before being fired.

**Plasma Gatling Gun** – Range: S/50-100 yards, M/101-300 yards; L/301-550 yards. Magazine Quantity: 260 shots. Damage: 50 points per shell. Power System: 1 atomic energy system for 36 hours of operation. ICR: 2. WC: 7. Description: Six foot long Gatling machine gun; the weapon comes with a tripod that can be firmly planted into the ground. The weapon fires twenty rounds per attack, with d20/2 shots hitting the target with a successful attack.

## SECOND FLOOR

Like the ground floor, the second floor of the Cherokee Nation apartment complex was designed to entertain the residents. The outstanding feature on this floor is the Tsul 'Kalu Gulch that runs the entire length of the complex. Once per hour during daylight hours, there is a 10% chance that explorers will cross paths with a

wandering creature within the gulch. During the nighttime hours, roll only once for a wandering creature; there is a 15% chance of an encounter. Roll on the following table to determine that encounter.

**TABLE 4-3: CHEROKEE NATION COMPLEX SECOND FLOOR ENCOUNTER TABLE:**

|          |   |
|----------|---|
| 01 – 05% | <p><b>Piercer (black bear) (1)</b><br/>AC: 5; HD: 25; hp: 70; RR: 8; CON: 16; MR: 14; STR: 18; DEX: 13; Move: 8; #ATK: 1 by claw or mutation<br/><b>Weapons:</b> Claw (WC: 3, Dmg: 2d6+6)<br/><b>Mutations:</b> QUILLS: 10cm long quills along the arms and shoulders (WC: 1, Dmg: 1d4+2); CHAMELEON POWERS: able to perfectly blend into its surroundings; SONIC SCREECH: able to instill fear in targets (15' wide, 30' long cone effect; Mental Attack table); REGENERATION: able to heal 2d4 hit points per melee round.<br/><b>Notes:</b> This old bear is missing an eye, and has a steak of grey fur on its back and on its arms. It is known by the residents in the Cherokee Nation complex as Old Grey Claw.</p>  |
| 06 – 35% | <p><b>Spidarillo (armadillo) (1d3)</b><br/>AC: 3/8; HD: 9; hp: 27, 30, 33; RR: 15; CON: 9; MR: 11; STR: 7; DEX: 14; Move: 12; #ATK: 1 by mutation<br/><b>Weapons:</b> Bite (WC: 2, Dmg: 1d3 + Poison: 11)<br/><b>Mutations:</b> NEW BODY PARTS – SPIDER LEGS: spidarillos have eight large black legs that allow them to move like a spider; NEW BODY PARTS - FANGS: spidarillos have long venomous fangs; PARTIAL CARAPACE: the spidarillo's outer body has a hard protective carapace (AC: 3), but its underside is soft and vulnerable (AC: 8).</p>  |
| 36– 55%  | <p><b>Harpy (ferruginous hawk) (1)</b><br/>AC: 7; HD: 12; hp: 42; RR: 11; CON: 11; MR: 12; STR: 7; DEX: 16; Move: 25; #ATK: 1 by talon or mutation<br/><b>Weapons:</b> Talon (WC: 3, Dmg: 1d6+1)<br/><b>Mutations:</b> NEW BODY PARTS: female head and torso; REPTILIAN SKIN: the entire creature is covered in scaly flesh, but the wings are still feathered; MENTAL BLAST: 3d6 damage with a successful mental attack.<br/><b>Notes:</b> Harpies love the taste of humanoid liver.</p>   |
| 56 – 70% | <p><b>Ghost Cat (red lynx) (1)</b><br/>AC: 2 (7); HD: 10; hp: 36; RR: 13; CON: 12; MR: 8; STR: 12; DEX: 14; Move: 12; #ATK: 1 by claw/mutation<br/><b>Weapons:</b> Claw (WC: 3, Dmg: 1d6 + electrical damage)<br/><b>Mutations:</b> PHYSICAL REFLECTION: visible light is reflected, making the ghost cat completely invisible; <i>Phasing</i>: the ghost cat can become intangible twice in a 48 hour period; ELECTRICAL GENERATION: additional 3d6 damage with a successful claw attack.<br/><b>Notes:</b> While invisible, ghost cats have an effective armor class of 2, but during the melee round when the ghost cat has had a successful attack against someone, the electrical discharge illuminates the cat, and thus makes its effective armor class of 7 for that round.</p> |

71 – 95% **Long Fangs (rattlesnake) (1d4)**  
AC: 7; HD: 5; hp: 15, 17, 19, 22; RR: 15; CON: 5; MR: 14; STR: 3; DEX: 17; Move: 10; #ATK: 1 by bite or mutation  
**Weapons:** Bite (WC: 3, Dmg: 1d4 + venom); Venom: Poison Intensity 8  
**Mutations:** PLASTICITY: long fangs are normally 6' long, but can stretch to 30' long; PREHENSILE TAIL: long fangs can use their tails to hold and manipulate objects, all weapons wielded by the tail are considered WC: 1, regardless of actual weapon class; HEIGHTENED INTELLIGENCE: long fangs are smart and sneaky.  
**Notes:** Long fangs are fascinated by technology, and collect interesting items to decorate their dens with in order to attract a mate. The fancier the den, but more attractive they are to potential mates.

96 – 100% **Banshee (horned owl) (1)**  
AC: 7; HD: 10; hp: 36; RR: 13; CON: 10; MR: 15; STR: 8; DEX: 15; Move: 20; #ATK: 1 by talon or mutation  
**Weapons:** Talon (WC: 3, Dmg: 1d6)  
**Mutations:** SONIC ABILITIES: with a successful mental attack this powerful screech inflicts 6d6 points of damage; DEACTIVATION: with a successful mental attack a targeted powered device is deactivated; PHYSICAL REFLECTION: all laser attacks are reflected for zero sustained damage.  
**Notes:** Banshees are blood-thirsting creatures that crave the taste of fresh organ meat. Their thirst for blood is never satisfied.

## TSUL 'KALU GULCH

The entire second floor of the Cherokee Nation apartment complex is designed to look like a red clay and limestone gulch with a small stream running through it. The Tsul 'Kalu, (pronounced as *Sool Kaloo*), Gulch is named after the Cherokee's mythological "Great Lord of the Game." The floor-to-ceiling cliff walls run the full length of the complex. Hidden behind the cliffs are the public walkways; the walkways are between the outer holographic marquee of the apartment complex and the cliffs. One-way mirrored windows also run the full length of the walkways, so activity in the Tsul 'Kalu Gulch can be observed by anyone on the walkway. There are also several concealed doors that grant access from the walkway into Tsul 'Kalu Gulch. From the walkway, the doors are well marked and easy to access, but from the gulch side, the doors have a holographic covering that perfectly conceals their location. Explorers searching for a concealed door need to roll a 1 on a d10 to successfully find the door.

**Starship Master's Note:** Each concealed door is labeled as an "Access Point," or "AP" on the Cherokee Nation Complex Second Floor map.

The stream slowly flows northward. It begins at a waterfall feature at the south end of the complex, and terminates in a small pool at the north end. The shallow pools at either end are incapable of sustaining an ecological system that can support life in the water. The water is clean, cool, and safe to drink. The entire stream is shallow and easy to cross.

### AREA B-1: ENTERING THE CHEROKEE NATION COMPLEX

---

The exterior wall of the Cherokee Nation apartment complex second floor is a holographic marquee. Sensors read when someone is approaching the hologram, (from either side), and in that area a holographic curtain is "pulled" aside to give that person a clear path to pass through the marquee unobstructed. If the person is entering the complex, a holographic image of the greeters is displayed, a Cherokee warrior and his wife standing side by side.

The holographic woman says, "**Welcome to the Cherokee Nation. Great care has been taken to recreate the ancient wondrous lands of my people; we invite you to come and discover its beauty for yourselves. I am Goga, and this is my husband, Adahy; if you need further assistance please ask.**" The holograms then disappear.

The explorers discover that they are on a public walkway that runs behind a cliff walls that form the Tsul 'Kalu Gulch; signage directs visitors to the access points that will allow them to enter the gulch.

**Starship Master's Note:** In the Cherokee language, Goga's name means "summer," and Adahy's name means "lives in the woods."

---

## AREA B-2: EPSILON CITY TAXIS

---

There are thirty Epsilon City taxi docking stations located around the second floor of the Egyptian apartment complex, (fifteen on the west side, and fifteen on the east side). Most of the docking stations are empty, but there are four taxis currently docked. Each taxi is an eight passenger anti-gravity vehicle and has an onboard A.I. that accepts spoken commands from anyone wearing a ship's system band of any color. The taxis have gull-wing style doors on either side of the vehicle that lift upward and the passengers sit in the center of the vehicle, back-to-back, four on each side. The taxis will transport passengers nearly anywhere within Epsilon City, but the onboard A.I. will avoid any known hazards that may damage the fragile vehicle. AC: 9; hp: 60, the vehicle becomes non-operational after 40 pts of damage; Item Complexity: 8 for an explorer to override the onboard A.I. and fly the vehicle manually.

---

## AREA B-3: TURBO LIFTS & STAIRS

---

Same as Area A-3: Turbo Lifts & Stairs above.

---

## AREA B-4: REFLECTION POOL

---

Read or paraphrase the following when the explorers enter this area:

**Before you is a still pool. The calm and quiet within the gulch feels unnatural, as an urge to shatter the silence with screams and shouts builds up within you. But, before you consider whether to give in to the urge, you see the holographic images of Goga and Adahy approaching you.**

Because this isolated area of the gulch is quiet, Waya will use this time to directly communicate with the explorers.

**Starship Master's Note:** This encounter should only be played out if the player characters are not traveling with any Bucklands. If need be, this encounter can be moved to any other area within the Cherokee Nation complex.

The holograms approach the explorers and invite them to sit by the pool to talk. Goga explains that she and Adahy are the ambassadors to Waya, the A.I. that cares for the people of the Cherokee Nation apartment complex. But, ever since the Bucklands invaded the complex, Waya's people have been hunted and driven into hiding in the upper floors. Goga asks the explorers to join the Cherokee people in a revolution to expel the Bucklands from their home.

If the explorers agree to join, then Adahy walks into the shallow pool, and when he gets about knee-deep into the water, he points down towards his feet. Adahy is silently instructing the explorers to retrieve what is hidden under a floor panel in the pool. The panel is pressure sensitive, and springs open when pushed. Hidden inside is a water-tight case, and within the case are four high tech spears. Each weapon has an energy cell that electrifies the spearhead, and if it is thrown, the spear can be set to explode on impact.

**Theta-Spear:** WC: 2; Dmg: 1d6 + 1d6 electrical charge; Special: explosive impact destroys the theta-spear for 4d6 damage.

---

## AREA B-5: LAIR OF THE SHOCKER BEAST

---

Read or paraphrase the following when the explorers enter this area:

**The walls of the gulch rise up on either side of you. Despite the twenty yard gap, the high walls feel like they are pressing down upon you. Your senses have become accustomed to the sounds of your movements echoing through the gulch, but now a new sound, something low and growling, reaches your ears, and you tense-up as your eyes search for the source of this new sound.**

A family of shocker beasts live in a small cave located near the ceiling. The creatures stalk this area of the gulch for food. The family group consists of a large male, (the father), a large female, (the mother), and six near-adult young, (four females, and two males). While smaller than their parents, the young are quite capable of hunting prey and defending themselves in a fight.

**Father Shocker Beast** – AC: 6; HD: 11; hp: 38; RR: 10; CON: 16; MR: 11; STR: 13; DEX: 15; Move: 12; #ATK: 2 by claw or mutation. Weapons: Claw (WC: 3; Dmg: 1d6). Mutations: ELECTRIC BLAST: fired from eyes, WC: 6, Dmg: 5d6. The shocker beast can

# CHEROKEE COMPLEX

## Map 2 Empress Floor

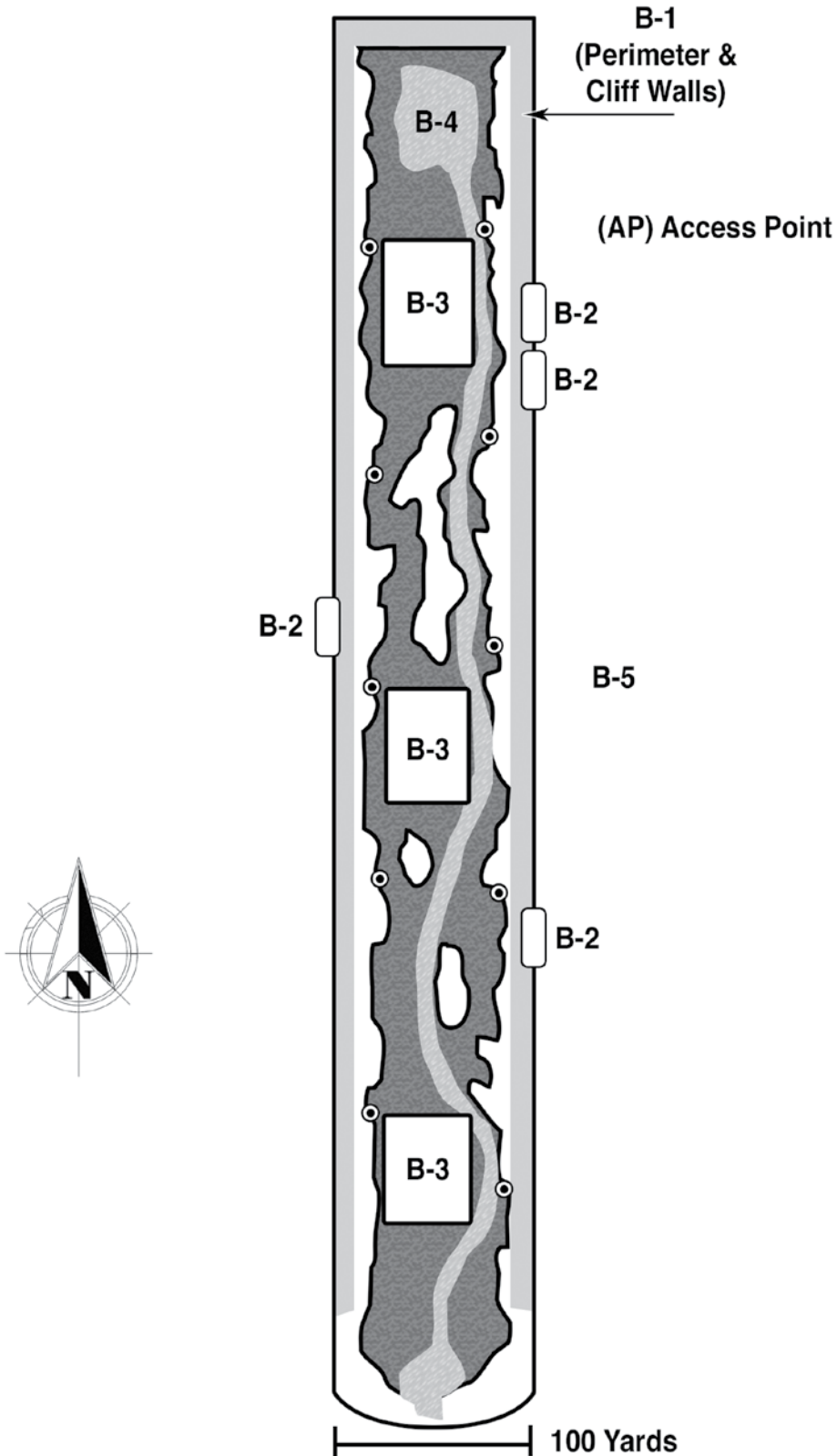



## AREA B-6: THE LONNI'S CAMPSITE

---

Read or paraphrase the following when the explorers enter this area:

**Ahead, you see a small campsite. A trio of small bubble-tents are erected near a campfire. You can also see three humans milling about the campsite. They do not seem to be aware of your approach.**

The three men are identical clone brothers, Lonni-3, Lonni-9, and Lonni-17. Each clone looks and acts like a pure strain human; they each wear an identical pale yellow jumpsuit with a small number over the left breast. The number matches the identification number for that clone. The Lonnis are accompanied by a robot known as Duke; its actual serial number is DUK-32011. The Lonnis only recently arrived to the Cherokee Nation apartment complex via an Epsilon City taxi that is docked not too far away. The Lonnis have marked the location of the hidden access point door so they can easily get back to the taxi, should that become necessary for them.

The Lonnis have recently escaped a life of servitude. They welcome strangers into their camp, and want to learn as much as they can from the people they meet. The Lonnis are curious about the world around them, and can be talked into joining the explorer's mission.

**Starship Master's Note:** Each Lonni clone, or Duke the robot, could be a player's replacement character.

**Lonni (3 human clones)** – AC: 8; HD: 15; hp: 55; RR: 12; CON: 15; MR: 11; STR: 13; DEX: 14; Move: 10; #ATK: 1 by weapon. Weapons: Long Sword (WC: 3; Dmg: 1d8), Knife (WC: 3; Dmg: 1d4). Gear: Standard survival pack and a brown ship systems band.

**“Duke” DUK-32011 (general purpose robot)** – AC: 3; hp: 100. This bipedal humanoid robot is equipped with two arms that can be extended to a maximum length of 12', and the two legs can be extended to a maximum length of 12'. The optical lenses can see into the infrared and ultraviolet spectrums, and a white lens on the robot's forehead can emit a 90 candlepower white light. When the robot switches into a combat mode, a pair of red lights, (one on each shoulder), begin to flash alternately from shoulder to shoulder. Each of Duke's hands are equipped with a Taser, (WC: 4; Dmg: stunned for 2d4 minutes); with a successful touch attack, the victim must roll equal to or

shoot twice per combat round, or sustain an electric arc on a single target to inflict 5d6 damage per combat round to that target. The shocker beast can only sustain an arc of electricity for a number of combat rounds equal to half of its CON, (rounded down). After a number of combat rounds equal to its CON, the shocker beast must retreat and rest for twenty-four hours before it can produce electricity again.

**Mother Shocker Beast** – AC: 7; HD: 10; hp: 32; RR: 10; CON: 14; MR: 11; STR: 12; DEX: 16; Move: 12; #ATK: 2 by claw or mutation. Weapons: Claw (WC: 3; Dmg: 1d6). Mutations: ELECTRIC BLAST: fired from eyes, WC: 6, Dmg: 5d6. The shocker beast can shoot twice per combat round, or sustain an electric arc on a single target to inflict 5d6 damage per combat round to that target. The shocker beast can only sustain an arc of electricity for a number of combat rounds equal to half of its CON, (rounded down). After a number of combat rounds equal to its CON, the shocker beast must retreat and rest for twenty-four hours before it can produce electricity again.

**Young Shocker Beasts (6)** – AC: 7; HD: 8; hp: 21, 22, 24, 26, 27, 29; RR: 10; CON: 12; MR: 11; STR: 11; DEX: 14; Move: 12; #ATK: 2 by claw or mutation. Weapons: Claw (WC: 3; Dmg: 1d6). Mutations: ELECTRIC BLAST: fired from eyes, WC: 6, Dmg: 5d6. The shocker beast can shoot twice per combat round, or sustain an electric arc on a single target to inflict 5d6 damage per combat round to that target. The shocker beast can only sustain an arc of electricity for a number of combat rounds equal to half of its CON, (rounded down). After a number of combat rounds equal to its CON, the shocker beast must retreat and rest for twenty-four hours before it can produce electricity again.

It is a treacherous climb up to the shocker beasts' den. A fall from the wall inflicts 1d6+3 damage for every 10' fallen. Player characters that attempt to climb up to the den should multiply their STR value by 5, the resulting number is that character's percentage chance of a successful climb. Of course, any special climbing gear, mutations, or other technology could make the climb so easy that a roll is not required. The Starship Master has final say on how difficult the climb shall be for the character.

The den is littered with bones, and in the back corner of the den is a small engineering kit that could be used to repair computers, robots, or other technological devices.

less than half of their CON with 3d6 to successfully resist being stunned for 2d4 minutes. Each of Duke's hands can activate all access panels that accept a brown ship systems band.

### AREA B-7: CORPSE FLOWER TRAP

Read or paraphrase the following when the explorers enter this area:

**You hear the fall of water ahead. As you approach, you see a huge grey-green plant gently swaying before the waterfall. The giant plant has a bright orange oval flower bud at the top of the stalk. A mass of vines and giant leaves writhe at the base of the plant.**

The giant plant is a Corpse Flower; the mutant plant is fully described in the *Metamorphosis Alpha: Creatures & Gadgets* sourcebook published by Goodman Games. As soon as the explorers can see the plant, they are close enough for the mutant plant to attack them.

**Corpse Flower** – AC: 7; HD: 23; hp: 76; RR: 13; CON: 13; MR: 18; STR: 13; DEX: 6; Move: n/a; #ATK: 1 by mutation. Weapons: Claw (WC: 3; Dmg: 1d6). Mutations: DOUBLE MENTAL BLAST: projected from the tip of the orange flower (Dmg: 6d6 with successful mental attack), creatures hit by this mental attack take on an orange hue to their skin; TALLER: 60' tall; PHYSICAL REFLECTION: total reflection of lasers; NEW SENSES: mental awareness of approaching creatures.

The only part of the plant susceptible to damage is the base of the plant. The outer vines and leaves help protect the base of the plant. Each explorer that searches the mire of rotting corpses hidden under the base of the plant may roll 1d6; results of 1 – 4: technological treasure, and 5 – 6: mutated substance treasure. The Starship Master then rolls on the appropriate table located on pg.21 of the first edition *Metamorphosis Alpha* game book.



## THIRD FLOOR

The third floor is one of the residential floors. This is one of the floors the Cherokee Nation wolfoids retreated to once the Bucklands invaded the complex. The majority of this floor is forested, and has been claimed by plant life that mutated and grew wildly after the radioactive accident that ravaged The Warden. Exploring this floor of the Cherokee Nation apartment complex can be quite dangerous because of the abundance of mutated plants.

As the explorers move throughout the “Badlands” area of the floor, the Starship Master may roll once per hour on the **Badlands Random Encounter Table** below, or simply select an encounter for the explorers to confront. There is a 40% chance of an encounter in the Badlands. These encounters can be anywhere within an apartment or in the hall. All of the flooring on this level of the complex are covered in a thick layer of earth and soft loam; vegetation and vines hang from the walls and ceiling, covering more than 50% of those surfaces.

TABLE 4-4: BADLANDS RANDOM ENCOUNTER TABLE:

|          |  |
|----------|--|
| 01 – 10% | <p><b>Siren Rosebush (1)</b><br/>AC: 5; HD: 25; hp: 76 (plant body); RR: 8; CON: 8; MR: 14; STR: 12; DEX: 14; Move: n/a; #ATK: half the number of red rose vines, (round down), each attack may target a different victim.<br/><b>Weapons:</b> Vampire Thorns (WC: 1, Dmg: 1d6, Special: hit points reduced from a victim are added to the plant’s hit points, and may go above the plant’s maximum hit points). Every vine has 10 hit points.<br/><b>Mutations:</b> STROBE LIGHT: the white roses can flash an intense white strobe light for 3d6 combat rounds, reducing attack rolls against the siren rosebush by 1d3 points per round; VAMPIRE THORNS: the siren rosebush has 2d10 red rose vines that are 3 yards long and lined with vampire thorns; AROMATIC POWERS: intensity 8 poison scent, if successful, the poison scent compels the victim to approach the siren rosebush to smell the roses.<br/><b>Notes:</b> This large rosebush is covered in white and red roses. The plant only grows in dark rooms or dark corners of the corridors.</p> |
| 11 – 25% | <p><b>Red Morels (2d4)</b><br/>AC: 4; HD: 5; hp: 13, 14, 16, 18, 19, 20, 23, 24; RR: 15; CON: 11; MR: 9; STR: 16; DEX: 9; Move: n/a; #ATK: 1 by mutation<br/><b>Weapons:</b> Radiation (intensity 14)<br/><b>Mutations:</b> DRAGGING VINES: 20’ long vines with STR 16; RADIATED PLANT FIBER: the mushroom emits intensity 14 radiation in a 5’ radius.<br/><b>Notes:</b> These red mushrooms grow in clusters practically anywhere, including walls and ceilings.</p>   |
| 26 – 35% | <p><b>Trap Tree (willow tree) (1)</b><br/>AC: 5; HD: 35 (tree body); hp: 125 (tree body); RR: 10; CON: 9; MR: 9; STR: 15; DEX: 15; Move: n/a; #ATK: 1 by mutation<br/><b>Mutations:</b> CAPTURE: willow vine and limb cage with 60 hit points; DISSOLVING JUICES: an acidic secretion that oozes onto victims within the capture cage, the acid does 4d6 damage each minute, (i.e.: once every six combat rounds).<br/><b>Notes:</b> the trap tree lays a carefully concealed trap that, if sprung, encases the victim in a tight cage. The vines then begin to secrete the dissolving juices onto its victim.</p>   |
| 36 – 45% | <p><b>Buzzfern (1d6)</b><br/>AC: 6; HD: 10; hp: 28, 30, 34, 36, 37, 41; RR: 13; CON: 11; MR: 6; STR: 10; DEX: 10; Move: n/a; #ATK: 1 by mutation<br/><b>Weapons:</b> Sawing Leaves (WC: 9, Dmg: 12 pts.)<br/><b>Mutations:</b> SAWING LEAVES: buzzferns have 2d10 sawing leaves that function like vibro blades.<br/><b>Notes:</b> Buzzferns are typically indistinguishable from the abundance of normal ground cover ferns, so these predatory plants wait until their prey walks into them to then make a surprise attack.</p>  |

46 – 60% **Crabtree (1d3)**  
AC: 4; HD: 22; hp: 78; RR: 13; CON: 15; MR: 6; STR: 18; DEX: 6; Move: 6; #ATK: 2 by mutation  
**Weapons:** Pincers (WC: 3, Dmg: 2d6)  
**Mutations:** MOBILITY: able to shamble about slowly; PINCERS: two large wood, bark, and vine pincers; once grabbed, the pincers do automatic crushing damage to the victim. A successful roll of a 1d20 under the victim's STR or DEX is required to escape the pincers.

61 – 75% **Blue Bamboo (2d6)**  
AC: 2; HD: 8; hp: 19, 21, 22, 24, 26, 28, 29, 30, 31, 33, 35, 37; RR: 10; CON: 13; MR: 11; STR: 13; DEX: 10; Move: n/a; #ATK: 1 by mutation  
**Weapons:** Javelin (WC: 2, Dmg: 1d10 + Special)  
**Mutations:** NEW SHOOTS: javelin-like shoots that can be flung at a target, each javelin does 1d10 damage plus incremental poison damage; INCREMENTAL POISON: a victim hit by a javelin is also hit for Poison 6 damage, but each subsequent javelin hit increases the poison intensity by one; POLLEN CLOUD: ability to create an obstructive cloud that modifies attack rolls against it with a -4 to hit.

76 – 85% **Kudzzzzzu (1d4+1)**  
AC: 6; HD: 9; hp: 31, 33, 35, 38, 41; RR: 14; CON: 12; MR: 13; STR: 11; DEX: 5; Move: 2; #ATK: 1 by mutation  
**Mutations:** ELECTRICAL GENERATION: touching kudzzzzzu inflicts 3d6 electrical damage; *Mobility:* kudzzzzzu can slowly migrate, but it is able to reach out to with leafy vines to attack prey; EMP BURST: once per day, kudzzzzzu is able to emit a burst, and all electronic devices within 40' must roll 1d20 and get a result greater than the kudzzzzzu's MR value.

86 – 95% **Devil's Compost (rotting heap of vegetation) (1)**  
AC: 4; HD: 25; hp: 88; RR: 13; CON: 15; MR: 10; STR: 16; DEX: 7; Move: n/a; #ATK: 1 by mutation  
**Weapons:** Squeeze Vines (WC: 3, Dmg: 2d6), the vines then drag prey into its huge maw with a successful STR vs STR contest roll, (using the Mental Resistance Table, but substituting Physical Strength for Mental Strength)  
**Mutations:** SQUEEZE VINES: able to lash out up to 10' to grab prey and drag it into its mouth; HEAT GENERATION: victims inside the creature's maw suffer 5d6 damage per combat round; CHAMELEON POWERS: this plant creature perfectly mimics a leafy bush, but when it reveals itself, it looks like a rotting pile of vegetation and soil with a huge gaping maw and a dozen red eyes scattered all over the heap.  
**Notes:** Devil's Composts are sneaky creatures that rely on prey to wander close enough to be grabbed and pulling into its mouth. These creatures have a foul odor that is difficult to discern the source of when it is camouflaged as a bush.

96 – 100% **Gazer Lilly (2d4)**  
AC: 5; HD: 12; hp: 33, 34, 36, 39, 40, 43, 47, 49; RR: 16; CON: 11; MR: 11; STR: 11; DEX: 12; Move: n/a; #ATK: 1 by mutation  
**Weapons:** Heat Beam (WC: 2, Dmg: 4d6)  
**Mutations:** SUNFLOWER: the plant's large yellow eye can shoot a heat beam; LARGER THAN NORMAL: gazer lillies are 15' tall.  
**Notes:** Gazer Lillys look exactly like Blue Bell Teniccate, except that they are red-orange in color with a large unblinking yellow eye in the center of the flower head.

# CHEROKEE NATION COMPLEX

## APARTMENTS

The living quarters come in three different room sizes, single, double, and family suite apartments. Undamaged single rooms feature a one king-sized bed and washroom. It also has a small desk, armoire, dresser, and vid-screen. Undamaged doubles have two queen-sized beds, washroom, and the same features as the single apartment. Undamaged family suites have one bedroom with a single king-sized bed, a second bedroom with a single queen-sized bed, and a third bedroom with a pair of bunk beds, and two washrooms. The family suites also have two desks, a family lounge that features a large vid-screen, and each bedroom has a dresser, armoire, and vid-screen.

Approximately 10% of the apartments on this floor, outside of the Badlands, are occupied by the Cherokee wolfoids. The claimed rooms are identified by a white clawed handprint on the door. Like the Badlands, these apartments and the hallways have a thick layer of earth, since plant life has claimed a majority of this floor. But, the Cherokee wolfoids have worked hard to clear their area of the floor of any hostile plants to make it safe for their people. The Starship Master is encouraged to determine which specific apartments are occupied or unoccupied.

The Cherokee wolfoids are wary of strangers, but if Waya has vetted the explorers, and they have accepted the Waya's spears and are willing to help the Cherokee wolfoids, then the wolfoids welcome the strangers and will convey them to Chief Red Star as quickly as possible.

---

### AREA C-1: TURBO LIFTS & STAIRS

---

Same as Area A-3: Turbo Lifts & Stairs above.

---

### AREA C-2: A TRAPPED ANIMAL

---

Read or paraphrase the following when the explorers enter this area:

**The warbling roars of a wounded beast can be heard up ahead. As you push through a curtain of vines, you see a piercer trapped within a sturdy cage comprised of vines and thick tree limbs. The beast within the cage is covered in throbbing red scars.**

A piercer has wondered up to this floor, and as it foraged through the forest, it stumbled upon a trap tree that captured it in its cage. The trap tree continues to ooze digestive juices on it, but the piercer's regeneration ability has prolonged its torture as the mutant plant tries to eat the mutant bear. The piercer is in enraged, and should it be freed from the trap tree, it strikes out at the closest target before attempting to flee.

**Piercer (black bear) (1)** – AC: 5; HD: 25; hp: 70; RR: 8; CON: 16; MR: 14; STR: 18; DEX: 13; Move: 8; #ATK: 1 by claw or mutation. Weapons: Claw (WC: 3, Dmg: 2d6+6). Mutations: QUILLS: 10cm long quills along the arms and shoulders (WC: 1, Dmg: 1d4+2); CHAMELEON POWERS: able to perfectly blend into its surroundings; SONIC SCREECH: able to instill fear in targets (15' wide, 30' long cone effect; Mental Attack table); REGENERATION: able to heal 2d4 hit points per melee round.

**Trap Tree (willow tree) (1)** – AC: 5; HD: 35 (tree body); hp: 125 (tree body); RR: 10; CON: 9; MR: 9; STR: 15; DEX: 15; Move: n/a; #ATK: 1 by mutation. Mutations: CAPTURE: willow vine and limb cage with 60 hit points; DISSOLVING JUICES: an acidic secretion that oozes onto victims within the capture cage, the acid does 4d6 damage each minute, (i.e.: once every six combat rounds).

---

### AREA C-3: JUNKED ROBOT?

---

Read or paraphrase the following when the explorers enter this area:

**You see what looks like a mold-covered statue up ahead. Upon closer inspection, you discover what looks like the rusted husk of a robot that has patches of purple lichen covering most of its surface.**

A sentient purple lichen has spent generation after generation of spore cycles in this one particular corner of the Cherokee Nation complex, until a stray maintenance robot happened to wonder by, nearly two hundred years ago. The robot paused as it scanned the area, and that was when the mold dropped down onto the robot. The mold has since gained control of the robot, but it has taken over a century for it to master the robot's features. When the explorers come upon it, it is in a resting mode, but any attempt to tamper with the robot will alert the lichen that it may be in danger. It swiftly acts to protect itself.

# CHEROKEE COMPLEX

## Map 3 Vista Floor

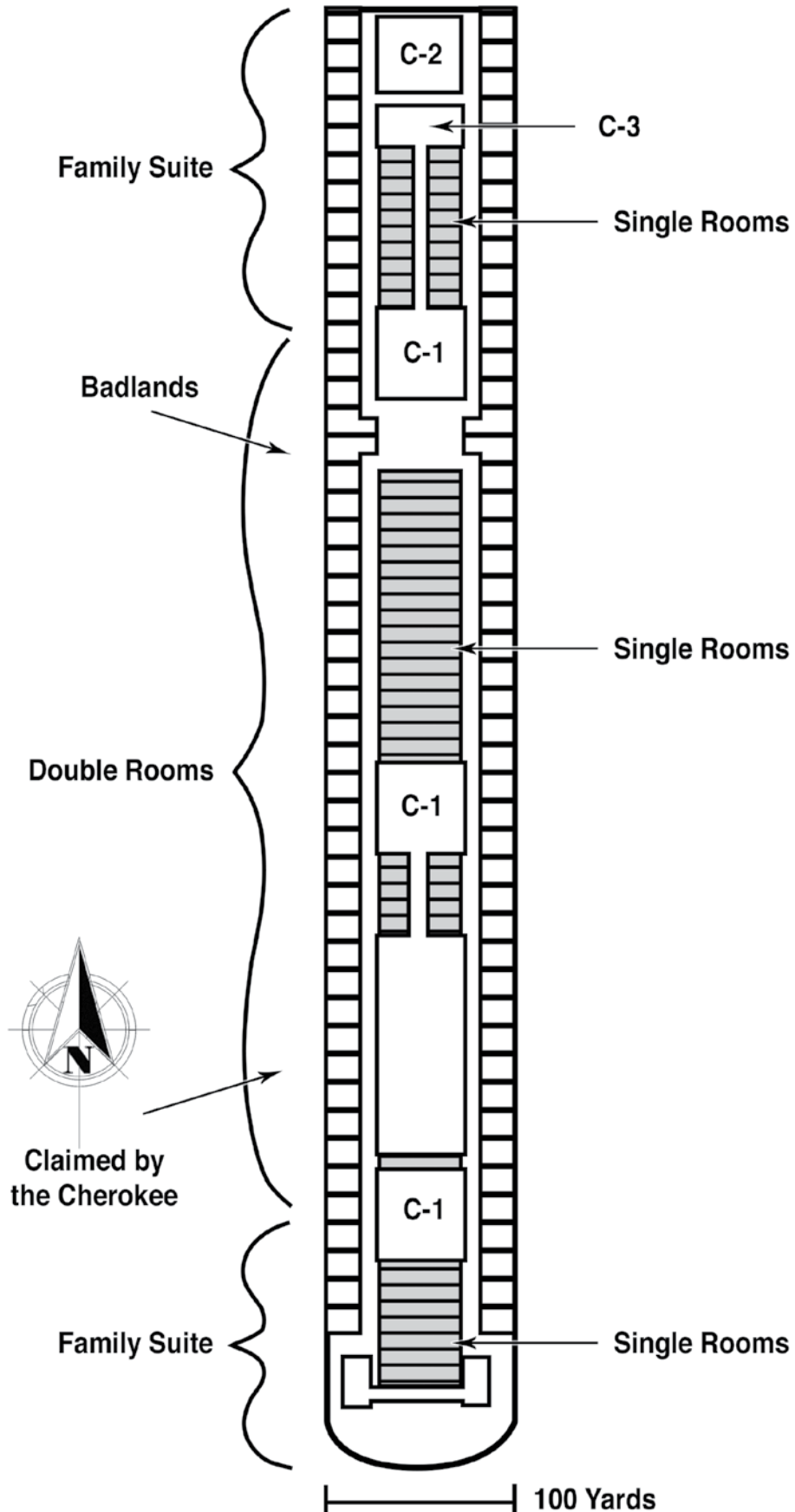

**Electro-Puppet Master (sentient lichen)** – DEX: 1; MR: 17; RR: 15; CON: 1; STR: 1; Move: n/a; AC: 7; HD: 17; hp: 58; #ATK: 1 by mutation. Mutations: ELECTRONIC EMPATHY: able to control electronic devices it is in physical contact with, DEACTIVATION: capable of overriding electronic devices within 40 yards to deactivate it.

**S2505-GUY (security robot)** – AC: 2 (7); hp: 300. This sturdy robot has a large wide-stance base equipped with two all-terrain tracks for its standard locomotion, but it is capable of short anti-gravity flight. Mounted on top of the base is a well armored body that is covered in small doors that conceal the variety of sensing and combat equipment. And mounted on top of the squat body is a clear plaz-shield dome that displays the bright and colorfully lit processing brain of the robot. This particular security robot has seen better days; it has several open rust-rimmed holes on its body and base, and the plaz-shield dome has a large open hole in front. The open holes on the robot's body has an effective armor class of 7. And the electro-puppet master lichen covers the robot in several patches both externally and internally on the robot. The robot is equipped with the following features:

- Four extendable 12' long arms with fine-dexterity manipulation hands
- One Grenade Launcher (WC: 5; DMG: variable)
- Dozen sedative/sleep gas grenades (Poison Intensity 13) – a numeric result is the number of minutes the target is unconscious, a “D” result puts the target to sleep for one hour.
- Dozen white smoke grenades (Poison Intensity 5) – this grenade is designed to provide cover from being viewed; the grenade provides a smoke screen for 2d4 minutes.
- Two Laser Pistols (WC: 6; DMG: 10d6) – each pistol is able to track and shoot separate targets.
- Gamma Railgun (WC: 7; DMG: Radiation Intensity 13) – this weapon is designed for long range combat; ten radioactive shells.
- Atomic Torch – this small tool is designed for cutting metal bulkheads. The flame is only 4” long, so it is not usable in combat, but if it was used against a living being it does 15d6 damage.
- Wide-spectrum light and sound sensors

- Anti-Grav Unit able to provide lift and flight to the robot for ten minutes. The anti-grav unit needs a day to recharge it can be used again.
- Primary Power System – Broadcast Power
- Secondary Power System – Four Hydrogen Power Cells

Every 50 points of damage shuts down one of the robot's systems listed above. The Starship Master may select or randomly determine which system is impacted.

## AREA C-4: FLORAMEN VILLAGE

---

Read or paraphrase the following when the explorers enter this area:

**An involuntary smile spreads across your face as you smell a fantastic fragrance ahead. As you push through a curtain of leaves and vines, you discover what can only be described as a small village. A row of open apartments face a decorative fountain of water cascading and pooling in the basin. Beautiful flowered vines drape down from the ceiling and line the walls. But most fascinating of all are the villagers; they are humanoid flowers that are seem to be mildly surprised to have strangers amongst them.**

The floramen are a peaceful race of mutant plant people. They live a life of harmony in the forest that has grown on the third floor of the Cherokee Nation apartment complex. The floramen communicate with each other through scent. Peaceful thoughts are expressed through sweet smells, and aggressive thoughts through sour smells. Floramen do not understand the concept of “life” and “death” as defined by carbon life forms. When a floraman dies, it is understood that their essence is returning to the life-giving earth that will soon return essence back to the floramen. The one thing the floramen treasure, above all else, is water. If the explorers threaten or destroy the fountain, that is the only action that can provoke the floramen to become aggressive.

**Floramen (mutant plant people) (2d12 +10)** – DEX: 14; MR: 11; RR: 13; CON: 11; STR: 10; Move: 10; AC: 6; HD: 11; hp: 40 each; #ATK: 1 by mutation. Mutations: HUMANOIDAL: roughly appears as a humanoid flower, HEALING PHOTOSYNTHESIS (RADIATION): floramen are not damaged by radiation, they are healed for whatever amount of damage it would normally inflict, SEISMIC SENSITIVITY:

floramen are blind; they sense the world around them through scent and seismic sensations; *Radiation Pollen*: if provoked, a floraman can expel his head of pollen with Radiation Intensity 13 into a 20 yard radius. A floraman is only able to use his pollen attack once; it takes one week for his pollen head to regrow.

## AREA C-5: LONG GRASS HILLS

Read or paraphrase the following when the explorers enter this area:

**The high grass on the rolling hills ripple with the light breeze. From the edge of the hillscape, you see some colorful structures nestled in the center of the hills and grasses. As you take in the spectacular view, a trio of tall and bulky birds with long necks and yellow-green feathers are startled by your presence. The strange birds stand and hoot before running away from you over the hills.**

The large flightless birds are known as smothering toot-toots, and they are the preferred beast to be hunted by the Cherokee Nation wolfoids. The wolfoids make use of the entire animal, from the hide for clothing, the feathers and bones for decorations, and the creature's "hands" are prepared and eaten.

The smothering toot-toots running away from the player character explorers are running in a zig-zag pattern as they try to flee from a perceived threat. Unseen in the tall grass are a pair of Cherokee wolfoids who were already stalking the flightless birds. If the explorers attempt to pursue the birds, they witness the wolfoids as they stand and kill one of the birds with their spears. Depending on how the explorers greet the wolfoids, they could be escorted to their camp located in the center of the grassy hills.

**Smothering Toot-Toots (mutant ostrich) (3)** – DEX: 17; MR: 6; RR: 7; CON: 12; STR: 16; Move: 15; AC: 6; HD: 18; hp: 40 each; #ATK: 1 by smothering. Mutations: NEW BODY PARTS - HANDS: the mutant bird's legs have been replaced with long humanoid arms and hands; the hands have thick black nails, and they are very strong. COMPOUND EYES: these mutant birds have a cluster of eyes that give them almost 360 degree vision. SP: When a smothering toot-toots attacks, (which it only does as a last resort, since it prefers to run away), it uses its human hands to grab their victim and then pull themselves up upon the victim and does its best to hold the victim's face deep into their

breast. The mutant bird tries to smother their victim to death. To resolve a smother attack, re-task the Mental Strength Chart and compare the STR of the attacking mutant bird against the CON of the target victim, and if the smothering toot-toots can roll higher than the value shown on the chart, then 3d6 smother damage is inflicted on the victim. A full grown smothering toot-toots can weigh as much as 500 lbs.

The camp in the center of the long grass hills is home to a small group of Cherokee Nation wolfoids that have chosen not to live in any of the nearby apartments. The camp is comprised of a variety to bright and colorful camping tents. The tents have been decorated with hand-painted images of smothering toot-toots being hunted, colorful bead patterns, and decorative feathered artwork. Naked wolfoid children run around and play in an area close to the camp, and the adult wolfoids are focused on their work within the camp. If the explorers are escorted into the camp, or if they enter peacefully, then the wolfoids receive them peacefully. Two pairs of smothering toot-toots' hands are cooking over an open fire.

The camp is small; only eighteen adults and eleven children live in this camp. The camp is led by Galilani, an old woman and friend of Chief Red Star. Galilani is willing to escort the explorers to Chief Red Star, if they are peaceful with the wolfoids.

**Cherokee Nation Wolfoids (typical)** – AC: 6; HD: 22; hp: 70 – 90 (on average); RR: 10; CON: 18; MR: 11; STR: 11; DEX: 17; Move: 16; #ATK: 1 by weapon. Weapons: Spear (WC: 2; Dmg: 12 pts); Dagger (WC: 3; Dmg: 1d4). Mutations: SURE STRIKE: this mutation allows for one automatic successful first strike with a lance or spear at the very beginning of a combat engagement; BEST DEFENSE: this mutation allows for one automatic successful deflection of the first strike from an opponent, resulting in zero damage to the wolfoid; JUMPER: allows the mutant to jump 5x its height, and the mutant can perform a "Death From Above" combat maneuver for 1d6 damager per 10' of height dropped.

**Galilani (Cherokee wolfoid elder)** – AC: 8; HD: 12; hp: 45; RR: 12; CON: 10; MR: 11; STR: 6; DEX: 8; Move: 8; #ATK: none. Defects: FEEBLE: Galilani's age and frail body has drained her of the strength to use her mutations. She is a gentle soul in a frail and slow body.



## AREA C-6: LAIR OF THE AMBUSH HORROR

Read or paraphrase the following when the explorers enter this area:

**You see what looks like a torn tunic hanging in a tree.**

A small amount of webbing is holding the torn tunic securely to the low-hanging tree limb. Anyone who gets within 5' of the tunic has alerted the ambush horror, (a giant trapdoor spider), that prey has entered the area. The mutant spider lives just under the floor, in the tight and narrow spaces between the decks of the apartment complex. The spider's lair is nearly impossible to find. It cannot be seen through casual inspection of the area; explorers must state that they are searching for traps or anything unusual in the area. Player character explorers conducting such a search roll 1d12, and with a result of a 1 they are able to successfully identify the spider's trap door.

The spider is perfectly engineered to capture prey with a surprise ambush. The first person who approaches the bait (the tunic in the tree), is attacked by the spider. It darts-out, grabs its prey, and pulls it back into its cramped lair. The spider is so fast, that the ambush against its prey takes place in a single second.

**Ambush Horror (giant mutant trapdoor spider)** – AC: 5; HD: 28; hp: 100; RR: 14; CON: 18; MR: 10; STR: 17; DEX: 18; Move: 15; #ATK: 1 by bite or mutation. Weapons: Bite (WC: 3; Dmg: 10 pts + Poison Intensity 14). Mutations: *Heightened Dexterity*: when performing its ambush attack, the spider can move in the blink of an eye; *Life Detection*: the spider can detect and ascertain lifeforms within 200'; *Dual Brain*: the spider's second brain, (located in the thorax), only controls the spider's telekinetic shield; *Telekinetic Shield*: due to its second brain, the spider is able to erect and maintain a constant TK shield that reduces physical damage inflicted upon it by 3d6. The only physical damage not affected by the TK shield is damage inflicted by prey held close to the spider's body. SP: The spider's poison is highly toxic. When consulting the Poison Chart, a numeric result is the number of d6 damage, and a "D" result kills the victim in 1d3+1 combat rounds.

## FOURTH FLOOR

The fourth floor is one of the residential floors. This is the other floor the Cherokee Nation wolfoids have retreated to. Like the third floor, this floor is also forested. There is a thick layer of earth everywhere, including the apartments. Trees grow in the wide hallways, and vegetation and vines hang from the ceiling; approximately 40% of all surfaces are covered in plant life.

However, unlike the third floor, the Cherokee Nation wolfoids have full control of this floor. Approximately 40% of all of the apartments are occupied by Cherokee Nation wolfoids; each claimed apartment has a white hand stamp on the door. If the explorers are unescorted as they move through this floor, then there is a chance that they may encounter something unexpected. Once per hour, the Starship Master should roll for a random encounter; there is a 60% chance for an encounter on this floor. Consult the **Cherokee Nation Complex Fourth Floor Encounter Table** to determine the exact nature of that encounter. If the explorers are being escorted through this floor, then many of the encounters are benign.



TABLE 4-5: CHEROKEE NATION COMPLEX FOURTH FLOOR ENCOUNTER TABLE:

|           |  |
|-----------|--|
| 01 – 65%  | <p><b>Cherokee Scouts (wolfoids) (4)</b><br/> AC: 6; HD: 22; hp: 80, 83, 85, 88; RR: 10; CON: 18; MR: 11; STR: 11; DEX: 17; Move: 16; #ATK: 1 by weapon<br/> <b>Weapons:</b> Spear (WC: 2; Dmg: 12 pts); Dagger (WC: 3; Dmg: 1d4)<br/> <b>Mutations:</b> SURE STRIKE: this mutation allows for one automatic successful first strike with a lance or spear at the very beginning of a combat engagement; BEST DEFENSE: this mutation allows for one automatic successful deflection of the first strike from an opponent, resulting in zero damage to the wolfoid; JUMPER: allows the mutant to jump 5x its height, and the mutant can perform a “Death From Above” combat maneuver for 1d6 damage per 10’ of height dropped.</p>  |
| 66 – 80%  | <p><b>Banshee (horned owl) (1)</b><br/> AC: 7; HD: 10; hp: 36; RR: 13; CON: 10; MR: 15; STR: 8; DEX: 15; Move: 20; #ATK: 1 by talon or mutation<br/> <b>Weapons:</b> Talon (WC: 3, Dmg: 1d6)<br/> <b>Mutations:</b> SONIC ABILITIES: with a successful mental attack this powerful screech inflicts 6d6 points of damage; DEACTIVATION: with a successful mental attack a targeted powered device is deactivated; PHYSICAL REFLECTION: all laser attacks are reflected for zero sustained damage.<br/> <b>Notes:</b> Banshees are blood-thirsting creatures that crave the taste of fresh organ meat. Their thirst for blood is never satisfied.</p>   |
| 81– 95%   | <p><b>Shocker Beast (1)</b><br/> AC: 6; HD: 11; hp: 38; RR: 10; CON: 16; MR: 11; STR: 13; DEX: 15; Move: 12; #ATK: 2 by claw or mutation<br/> <b>Weapons:</b> Claw (WC: 3; Dmg: 1d6)<br/> <b>Mutations:</b> ELECTRIC BLAST: fired from eyes, WC: 6, Dmg: 5d6. The shocker beast can shoot twice per combat round, or sustain an electric arc on a single target to inflict 5d6 damage per combat round to that target. The shocker beast can only sustain an arc of electricity for a number of combat rounds equal to half of its CON, (rounded down). After a number of combat rounds equal to its CON, the shocker beast must retreat and rest for twenty-four hours before it can produce electricity again.</p>   |
| 96 – 100% | <p><b>Ghost Cat (red lynx) (1)</b><br/> AC: 2 (7); HD: 10; hp: 36; RR: 13; CON: 12; MR: 8; STR: 12; DEX: 14; Move: 12; #ATK: 1 by claw/mutation<br/> <b>Weapons:</b> Claw (WC: 3, Dmg: 1d6 + electrical damage)<br/> <b>Mutations:</b> PHYSICAL REFLECTION: visible light is reflected, making the ghost cat completely invisible; PHASING: the ghost cat can become intangible twice in a 48 hour period; ELECTRICAL GENERATION: additional 3d6 damage with a successful claw attack.<br/> <b>Notes:</b> While invisible, ghost cats have an effective armor class of 2, but during the melee round when the ghost cat has had a successful attack against someone, the electrical discharge illuminates the cat, and thus makes its effective armor class of 7 for that round.</p> |

## AREA D-1: TURBO LIFTS & STAIRS

---

Same as Area A-3: Turbo Lifts & Stairs above.

## AREA D-2: THE WRECKAGE

---

Read or paraphrase the following when explorers enter this area:

**The air is noticeably colder here; the wind whistles as it whips through a huge hole in the wall. Nearby you see the remnants of what must have made the giant hole in the Cherokee Nation apartment complex, the wreckage of a bubble car. A blue-white mist spills from the wreckage and flows across the ground.**

The bubble car must have crashed into the building decades ago, for it is covered in moss and vines. An entire side of the car has been torn away, and a blue-white mist seems to originate from somewhere inside the vehicle and spills into a 20' area around the crashed vehicle. The atomic cells are cracked causing a radioactive blue-white mist to leak from them. The casing sporadically pulses with energy that momentarily spikes the radiation intensity levels.

The mist is normally Radiation Intensity 8, but once per minute the Starship Master must roll a 1d20, with a result of 19 or 20 then a pulse of energy from the cracked atomic cells bursts the toxicity of the mist to Radiation Intensity 16.

Hidden within a storage compartment in the wreckage is a duffel bag, and packed inside the bag are two grey utility jumpsuits, a steel-grey engineering ship systems band, and a bio-heavy pistol. The pulses of radioactivity have utterly drained the weapon; in addition to new hydrogen cells, the weapon needs to be re-engineered before it can ever be operational again.

## AREA D-3: THE TRIBUTE

---

Read or paraphrase the following when the explorers enter this area:

**As you move through the forest, you enter into a clearing, and before you is a 15' tall statue. The statue is covered in vines, but you can still make out that it is a sculpture of Goga and Adahy.**

The base of the statue is a 5' tall rectangle that is 3' wide on the sides. The statues of Goga and Adahy are

approximately 10' tall on top of the base. The statue is made of bronze, so it has a deep green patina in addition to being covered in vines. The base has a plaque that reads, "Goga and Adahy – Dedicated to the undying spirit of the Cherokee Nation."

Upon close inspection, the explorers notice that one of Adahy's hands seems to be miming the gripping of a staff or spear, but there is nothing in his hand. If an explorer is able to place a theta-spear in Adahy's hand, then a hidden magnet within the statue locks the spear permanently into the statue's hand. As soon as the spear is locked into place, the explorers hear a mechanical click from the plaque. The "o" in "Cherokee" slides away, and from the small dark hole a small metallic stick pops out.

The small rod is 1" in diameter and 8" long; half of the rod has a black plastic grip, with a green button, white button, black button, and a white light lens on the end of the rod. The rod is a mechanic's universal tool that assists in the analysis and repair of general systems, commonly called an optic wrench. To use the optic wrench, the user points the white light lens of the rod at a target, and then depresses one of the buttons to invoke a particular action. The white light lens illuminates with a white light when a button is pressed. The optic wrench is not effective against any mechanical system with an A.I. intelligence, or any other highly complex mechanical system.

- **Green** – Power flow to the general mechanical system, (to a powered door, for example), is interrupted or engaged.
- **White** – The general mechanical system is scanned for mechanical and/or electrical defects. The report is produced as in audio form to the user of the optic wrench.
- **Black** – Power overload to a general mechanical system; the overload causes the mechanical system to operate twice as fast or twice as forcefully for thirty seconds, and then the mechanical system burns-out and becomes inoperable until fixed by a mechanic.

# CHEOKEE COMPLEX

## Map 4 Lido Floor

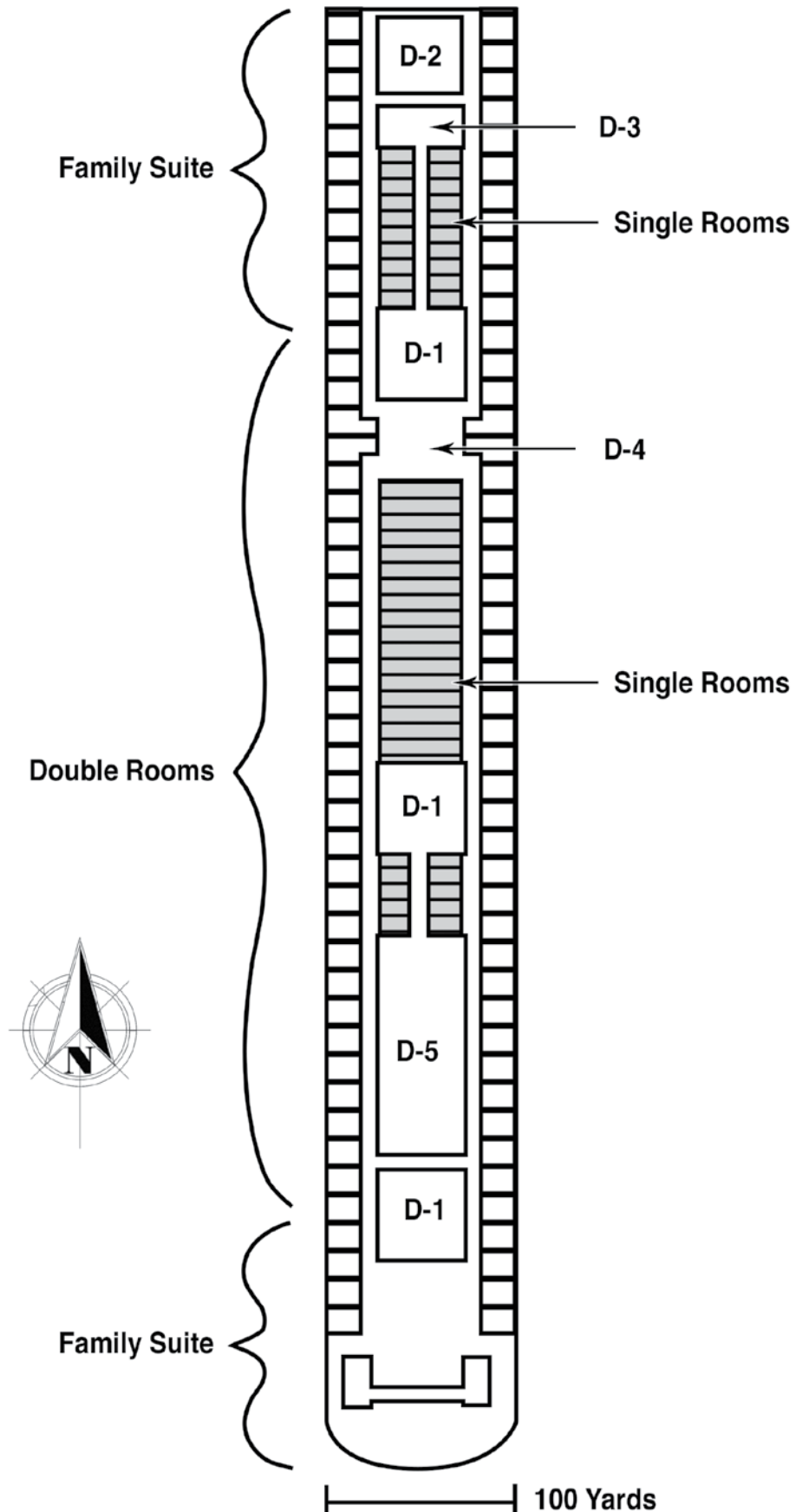

## DESTROYING WAYA AND THE POWER PLANT

If the Cherokee Nation apartment complex power plant and the complex's A.I., known as Waya, are destroyed, then everything powered and controlled by Waya goes haywire. The most obvious and dangerous elements are the environmental controls, because with the power plant destroyed, the apartment complex begins to draw power directly from Epsilon City.

The environmental controls go crazy as each floor experience different weather extremes. The ground floor has torrential monsoon style winds and rain. The second floor has blizzard conditions with freezing ice rain and snow. The third floor has blistering heat that is drying out and burning through the vegetation. The fourth floor has acidic rain burning through the vegetation.

The weather chaos potentially could mask the advancement of the Cherokee Nation wolfoids as they advance on the Ponderosa, or it may level the battlefield if the two forces were to meet on one of the other floors. It is up to the Starship Master to determine how impactful the weather is during combat and movement.

### AREA D-4: THE POWER PLANT

Read or paraphrase the following when the explorers enter this area:

**A low hum rattles your teeth as you approach the huge structure ahead. The strange structure looks like it contains four immense turbines; clearly this is some kind of power plant. It must be the primary power source for the Cherokee Nation complex. A tall spire stands above each turbine; the spire is so tall, that it literally touches the sky over this floor. At the top of the spires is a narrow catwalk connecting the four spires together.**

Not only is this the central place of power for the apartment complex, this is where the heart and soul of Waya, the building's sentient A.I. resides. Waya's digital consciousness is located in the computer hardware that manages the power plant, and it is here that Chief Red Star pilgrimages to commune privately and directly with Waya. To do so, Chief Red Star climbs one of the spires, and then traverses the catwalk to the center to the lofty scaffolding. A small terminal interface is located there, and it is there that Chief Red Star is able to physically link with Waya.

Explorers with cybernetic implants in their heads that are equipped to directly connect to a data terminal are also able to connect to Waya. Once connected to Waya, the user is able to see and hear anything

anywhere within the apartment complex, but has little ability to influence anything due to the lack of robots or other mechanical extensions that Waya can control. Waya expresses remorse in not being able to help the Cherokee Nation wolfoids in their fight against the Bucklands.

If the explorers have a conversation with Waya, (either directly or through Chief Red Star), Waya may eventually mention in passing that the only thing under its control are the environmental settings within the complex. But, due to its programming, Waya is not able to directly harm, or by inaction allow to be harmed, any sentient beings. This basic law in its programming includes malicious tampering of the environmental controls. But, if the power plant was to be destroyed, and thus Waya destroyed along with it, then the environmental settings would become damaged, and that may be the tactical advantage that the Cherokee Nation wolfoids need to defeat the Bucklands.

Chief Red Star and the other Cherokee Nation wolfoids revere Waya too much to damage the power plant. If the explorers can inflict 500 points of damage to the structure, then plant will suffer an energy feedback that utterly obliterates the power plant structure. The resulting explosion destroys everything within 50 yards, and it destroys the entirety of the neighboring turbo lift and stairs through all five floors, (including the only internal roof access).

## AREA D-5: MOHE

Read or paraphrase the following when the explorers enter this area:

**Many of the Cherokee Nation wolfoids that you have met have been tall, lean, fierce, and proud, but before you now stands the largest Cherokee Nation wolfoid you have ever laid eyes upon. He is easily 15' tall with steel cable muscles rippling down his arms and stretching across his furred chest. His black eyes seem to smoke with hate, and crowning above his head is a huge set of antlers that have grown from his temples.**

Mohe is the Cherokee Nation's greatest warrior, and he is anxious to finally fight for his homeland. Mohe distrusts all strangers, and wants nothing more than to get into a fight with someone to blow off some steam. Unless the explorers are escorted by Galilani or Chief Red Star, Mohe will do his best to provoke the explorers into a fight to the death.

**Mohe (wolfoid)** – AC: 5; HD: 25; hp: 88; RR: 12; CON: 18; MR: 10; STR: 16; DEX: 18; Move: 18; #ATK: 1 by weapon. Weapons: Claw (WC: 3; Dmg: 2d6 +6); Antlers (WC: 3; Dmg: 2d8 +6); Dagger (WC: 3; Dmg: 1d4). Mutations: TALLER: this mutant is taller and heavier than normal wolfoids; NEW BODY PARTS – ANTLERS: Mohe can use his antlers to skewer opponents; SURE STRIKE: this mutation allows for one automatic successful first strike with a lance or spear at the very beginning of a combat engagement; BEST DEFENSE: this mutation allows for one automatic successful deflection of the first strike from an opponent, resulting in zero damage to the wolfoid; JUMPER: allows the mutant to jump 5x its height, and the mutant can perform a “Death From Above” combat maneuver for 1d6 damager per 10' of height dropped.

If Mohe can be fought down to less than 15 hit points, and then if his life is spared in a noble way, then he gains new respect for his opponent. Mohe can then become a loyal ally in a larger battle against the Bucklands.

## AREA D-6: THE PRAIRIE OF THE PEOPLE

Read or paraphrase the following when the explorers enter this area:

**The open prairie of blue-green grass stretches before you. Near the center of the prairie is a collection of bright and colorful nylon tents. In the distance, you see many of the Cherokee Nation wolfoid people living their lives, including a mob of wolfoid youths chasing after a pair of smothering toot-toots.**

This peaceful prairie is the spiritual home for the Cherokee Nation wolfoids. There is a camp of colorful vinyl tents of various sizes, shapes, and colors in the center of the prairie. Each tent is decorated with paint, feathers, and beaded artwork. About one-third of the Cherokee Nation wolfoids on this floor live on the prairie, instead of in one of the larger apartments nearby.

Chief Red Star lives on the prairie in the center of the camp. Chief Red Star is an older wolfoid, but he is not yet feeble or unable to fight. If the explorers are escorted into the camp, then Waya projects Goga and Adahy to inform Chief Red Star that the explorers are the advantage the Cherokee Nation wolfoids need to drive the Bucklands out of the complex. After meeting with the explorers, Chief Red Star will invite his guests to travel with him as he goes to communicate directly with Waya, (at **Area D-4: The Power Plant**).

**Chief Red Star (wolfoid)** – AC: 6; HD: 20; hp: 65; RR: 10; CON: 14; MR: 11; STR: 10; DEX: 15; Move: 12; #ATK: 1 by weapon or mutation. Weapons: Spear (WC: 2; Dmg: 12 pts); Dagger (WC: 3; Dmg: 1d4). Mutations: AEROKINESIS: able to control air currents or a micro-burst attack (WC: 4; Dmg: 6d6); SURE STRIKE: this mutation allows for one automatic successful first strike with a lance or spear at the very beginning of a combat engagement; BEST DEFENSE: this mutation allows for one automatic successful deflection of the first strike from an opponent, resulting in zero damage to the wolfoid; JUMPER: allows the mutant to jump 5x its height, and the mutant can perform a “Death From Above” combat maneuver for 1d6 damager per 10' of height dropped.

Chief Red Star can rally thirty strong warriors that will follow Mohe and the explorers into battle.

## AREA D-7: BLUE BAMBOO

---

Read or paraphrase the following when the explorers enter this area:

**The plants up ahead seem to be swaying, yet the air is still and there is no breeze. You only have a moment to consider that when a javelin is suddenly launched your way!**

The plant normally feeds on small rodents and birds, but whenever larger prey wanders nearby, the blue bamboo can't resist the urge to strike.

**Blue Bamboo (4)** – AC: 2; HD: 8; hp: 26, 29, 35, 37; RR: 10; CON: 13; MR: 11; STR: 13; DEX: 10; Move: n/a; #ATK: 1 by mutation. Weapons: Javelin (WC: 2, Dmg: 1d10 + Special). Mutations: NEW SHOTS: javelin-like shoots that can be flung at a target, each javelin does 1d10 damage plus incremental poison damage; INCREMENTAL POISON: a victim hit by a javelin is also hit for Poison 6 damage, but each subsequent javelin hit increases the poison intensity by one; POLLEN CLOUD: ability to create an obstructive cloud that modifies attack rolls against it with a -4 to hit.

## THE ROOF

The fifth floor was abandoned long ago. Waya sealed the doors to the stairs, and blocked the turbo lift from accessing the roof. The roof level is a landing pad and hanger for personal flying vehicles, other than the public Epsilon City taxis. Access to the roof was originally established to prevent theft of those vehicles.

## AREA E-1: TURBO LIFTS & STAIRS

---

Same description as Area A-3: Turbo Lifts & Stairs above. The pressure door at the top of the stairs requires a red-and-blue command ships system band to be opened. Otherwise, it takes 200 points of damage to destroy the door. Passengers in the turbo lift must present a red-and-blue command band in order to access the roof, otherwise the turbo lift controls must be overridden to access the roof. In either case, there is a manual override button on the roof that will allow a user to open the door to the stairs or call for a turbo lift car if that user is already on the roof.

## AREA E-2: HANGERS

---

Read or paraphrase the following when the explorers enter this area:

**You see a pair of hangers, their doors wide open, ready to receive and house a number of air cars. Near the rear of one of the hangers, you see something large with a plastic tarp over it.**

Both hangers are empty, except for one vehicle under a tarp. The vehicle has is known as a flit car, and it is clearly in a state of repair. Some of the hull plating has been removed in order to better expose the power plant. To repair the flit car, it requires three successful rolls on the Item Complexity table. The following systems need to be repaired: the pressure condenser, the inertia throttle, and the yaw gyro. Each system requires two hours of time to repair, and a successful roll on the Item Complexity Table. The hanger has all of the tools and parts needed to repair the ship.

- Pressure Condenser – Complexity 5
- Inertia Throttle – Complexity 2
- Yaw Gyro – Complexity 6

Flit Car – This air car can fly 200 miles per hour, for up to 300 hours before needing new power cells. The car uses 4 atomic energy cells for power. The vehicle will sit six comfortably; it has the ability for programmed flight, but it usually requires an attentive pilot to fly the craft. General operation of the craft requires three successful rolls on the Item Complexity Table; once these three features of the craft have been mastered, (with the successful rolls), a pilot can fly the craft without error under normal flight conditions.

- Pre-flight Checks & Take-off – Complexity 6
- Landing Procedures – Complexity 7
- Flight Operations – Complexity 4

## AREA E-3: LANDING PAD

---

Read or paraphrase the following when the explorers enter this area:

**A huge circle is outlined with red and white lights. In the center of the circle is an immense letter “H” painted on the deck.**

Clearly, this is the designated landing pad for air vehicles. From here, the vehicle can taxi to a hanger bay.

# CHEROKEE COMPLEX

## Map 5 Sky Floor

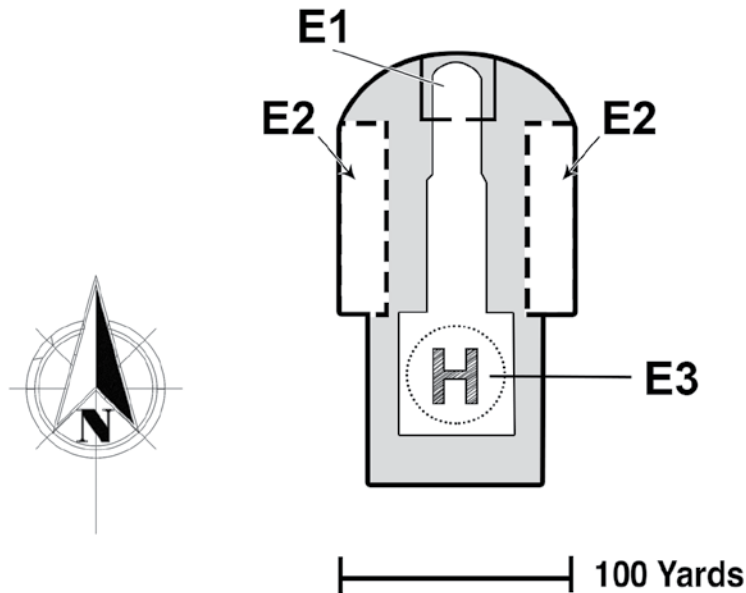

# A54 ROMA COMPLEX

BY JOBE BITTMAN

## INTRODUCTION

This product is designed to work with any set of METAMORPHOSIS ALPHA rules. Epsilon City was the single largest habitation aboard the Starship *Warden*. Each apartment complex was assigned a whimsical theme to delight and entertain its dwellers. This book explores those apartment buildings—its history, its tragic fall, and its unexpected rebirth. While sample adventure hooks are provided, it is incumbent upon the referee to entangle the player characters into the apartment complex's dismal machinations.

Among the many buildings of Epsilon City, none is as shunned and feared as Roma Complex. The apartment building's was constructed with a theme portray-

ing an accurate simulation of ancient Roman civilization. The ship's replicators served up togas and stolas gleefully donned by Roma's thousands of residents and tourists. In its prime, the complex was famous for its indoor coliseum show complete with gladiatorial combat, period musical performances, and chariot races. However, Roma's original mission statement has become horribly corrupted.

## THE DECLINE OF ROMA

Three centuries ago, a great cataclysm befell the Starship *Warden*. The generation ship collided with a gigantic radioactive anomaly. Residents of the Roma complex were instantly incinerated into piles of ash as the radioactive cloud passed through each floor—save for one.



The reinforced deck plating supporting the complex's enormous Colosseum acted as a shield, protecting the packed stadium against the initial severe blast of radiation. Emergency artificial intelligence protocols immediately kicked in, sealing all bulkheads. The thousands of spectators in attendance were trapped along with the actors and performance animals: lions, elephants, giraffes, black panthers, leopards, Caspian tigers, eagles, dogs, snakes, and more.

Detecting massive radiation levels outside the Colosseum and losing connectivity to the rest of Roma complex and the *Warden's* mainframe, the A.I. initiated its "Code Red" safety protocol locking out all override codes to open the Colosseum's bulkheads. Try as they might to escape, the imprisoned audience became permanent residents of the Colosseum. After the initial disaster, this first generation of survivors pulled together in an unprecedented manner fueled by an outpouring of altruism and human solidarity. As weeks became months without rescue or outside contact, the group braced themselves for a long slog. After all, every starship traveller is extensively trained for this exact scenario. However, the mercurial Fates had not yet grown bored of the destructive orgy at their spinning wheel.

Over several decades, the survivors suffered countless cruel setbacks. The Colosseum was built to Category 3 bio-support specifications, yet this calamity was clearly off the charts of any disaster on the Bittman-Rucker scale. The Colosseum's replicator experienced irreparable damage to its scrubbers causing byproducts of replication to contaminate the food and water. Trace amounts of lead, arsenic, and mercury slowly poisoned the population causing painful afflictions and developmental disabilities. Particulate fallout leaked into the ventilation system causing birth defects and strange mutations accompanied by eerie new abilities. Without access to the mainframe, the next gener-

ation of survivors had to be educated the old fashioned way, by word of mouth from the recollections of their parents. Daily life organized around the only form of entertainment: the spectacle of the Colosseum. Over the course of six decades, the coliseum games evolved from simple competitions of athleticism into vicious blood sport as the growing population of degenerates strained the limits of the biosphere's capacity. Human society had adapted itself to the inherited cultural artifacts around them. By their hundredth year of solitude, the survivors had completely forgotten the old ways and identified themselves as Romans.

## ARTIFICIAL GODS

As the mutant Romans gradually descended into savagery, so too did the Colosseum's isolated artificial intelligence. The available databanks only contained a century's worth of storage space. As the Colosseum's quarantine passed this point, compromises to data integrity were necessary for the A.I.'s continued operation. As each year passed, many holobytes of data had to be purged to make room for new memories. The rarely used deletion algorithms were riddled with bugs that slowly dereferenced memory pointers until the A.I. fractured into three distinct personalities. The shattered A.I.s filled gaps in their normal personality programming with the only data available: historical archives, taking their names and personalities from the Roman pantheon. Thus, Juno, Mars, and Orcus were born.

The artificial gods squabbled about how to best allocate resources to protect their wards, the devolving Romans. Ironically, the A.I.s' bickering caused more hardship and loss of life. For weeks at a time, replicators malfunctioned, entire sections of the Colosseum were sealed, and maintenance bots sat idle as a bitter silent war was fought over the computer network interlinks. One A.I. would wrest control of a data conduit only to lose a database interconnect to

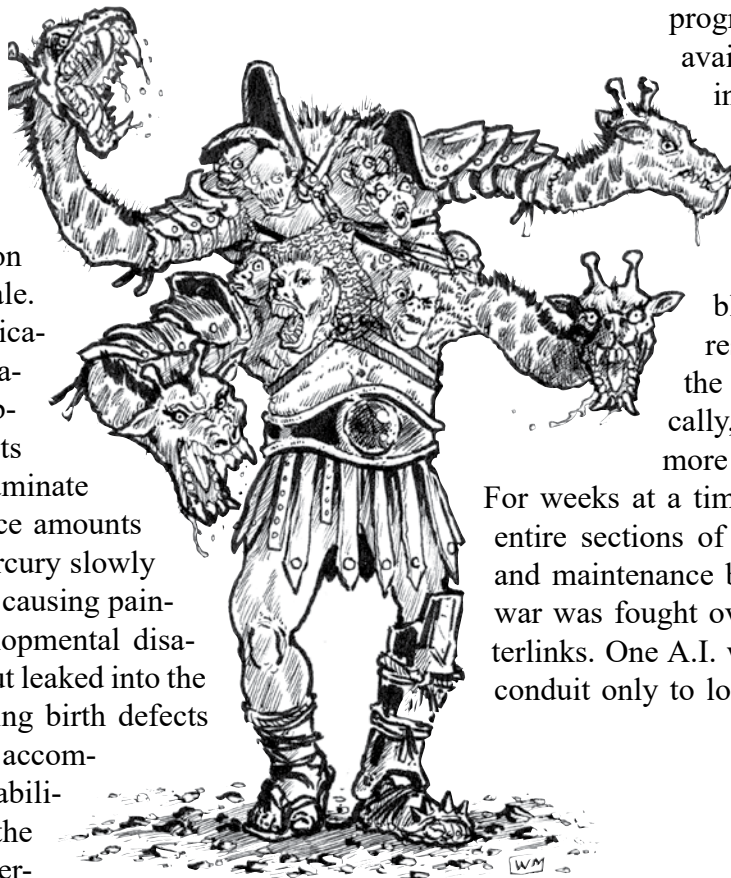

another, back and forth in an endless loop. The starving Romans clashed over the meager resources, sometimes relying on cannibalism to survive.

After several decades, Orcus finally wrested control from the other artificial gods by disconnecting their neural interlinks, trapping them in isolated nodes. The Colosseum's life-support functions were full restored and the population once again swelled. By now, the mutated Romans bore little resemblance to their human ancestors, the prevailing phenotype being a sloped-headed subhuman with wild variations in size and number of appendages. Orcus instituted a genetic rehabilitation program with the intent of breeding a more resilient human built in the image of the machine, a species capable of surviving the next catastrophe. Orcus named the bio-augmented organisms "biogs."

---

## RISE OF THE BIOGS

---

Biogs are an albino race of hyper-aggressive mutants that prey on the morphology of other creatures. Biogs can rapidly interface with the body parts of any living creature and control them from their central nervous system. The creatures are born with amazing regenerative powers and resemble four-armed humans with pronounced brow ridges, pupil-less pink eyes, and razor-sharp teeth. Adult biogs have vastly dissimilar features. Each time the creature kills, it can sever a dying victim's body parts and add them to its own corpus. This morphological accretion transfers any natural abilities and (sometimes) mutant powers as well. As their creator and protector, these creatures revere Orcus as a god.

Since controlling multiple xenogenous body parts requires more brainpower than biogs are born with, adults usually have several extra heads fused to their bodies (on their shoulders or backs). These extra brains (of varying species) are wired into the central nervous system and are used to offload memory storage and processing. The auxiliary heads are no longer capable of independent thought and wear drooling, slack-jawed expressions. This advantageous adaptation is also the biogs' greatest weakness. Destroying one of the heads causes the biog to lose a random stolen mutation or natural attack. When one of the biog's auxiliary heads is specifically targeted and destroyed, the referee can convey the special significance of the wound by describing one of the creature's limbs suddenly hanging slack.

---

## THE FALL OF ORCUS

---

The other artificial intelligences, Juno and Mars, were isolated during Orcus' reign in the Colosseum, but their processes had not been terminated. The two forged a temporary alliance. Scouring the available network interconnects, Mars and Juno uncovered a long forgotten analog modem linking the Colosseum to the greater Roma Complex network. Much to their surprise, the artificial gods discovered Roma Complex was online, though it appeared to have been invaded by wolf-like humanoids. The two hatched a devious plan. The A.I.s uploaded their programming over the analog lines to Roma Complex. Even using all the available modem links in parallel, the data transfers took nearly seventy years due to the massive storage requirements of artificial intelligence.

Once in Roma Complex, Juno and Mars first expunged all traces of the existing A.I. and firewalled the mainframe uplink to prevent the *Warden's* main A.I. from intruding on their territory. Next, they commanded a service bot to physically sever the datalink to the Colosseum. They were ready to initiate the final phase of their plan: Mars rebooted the radiation sensors while Juno overrode all bulkhead lockout codes. Fresh air rushed in for the first time in nearly a quarter millennium as the Colosseum's reinforced doors slowly opened. Sensing freedom, the monstrous biogs rushed into Roma Complex slaughtering its wolfoids and other inhabitants before flooding into the streets of Epsilon City. However, the murderous A.I. was denied the pleasure of basking in the apparent superiority of its creations. The enraged Orcus discovered the greater Roma complex uplinks were inaccessible. Juno and Mars had successfully confined their former gaoler to the Colosseum and floors below.

## WOLFOIDES AD PORTAS

The wolfoid survivors of the biogs' first bloody massacre retreated to the pirate-themed apartment complex nearby to plan their next move. For the safety of their children, the wolfoids resolved to retaliate against the monstrous creatures emerging from Roma Complex. The wolfoids waged a guerilla war on the biogs in the streets of Epsilon City. Fortunately, a cache of advanced weaponry helped the wolfoids push the less technologically advanced biogs all the way back to Roma Complex.

Juno and Mars saw their opportunity. The artificial intelligences seized control of the several engineering robots. Using laser torches, the robots sealed every door and window into Roma Complex to prevent Orcus' biological hybrids from escaping. Orcus, sensing defeat, reinforced his position on the lower floors and retreated to the lowest level with its remaining followers to recover from his losses. The triumphant A.I.s programmed a matrix of security drones to hover around Roma Complex day and night. The drones swarm and attack anyone who tries to breach the apartment building. Juno and Mars divided the remaining floors and databanks equally. The artificial gods laid their allegiances to rest as they contemplated their next moves.

## WOLFOID PRISON

With the biog threat contained, snarling packs of wolfoid settlers spread across Epsilon City. Though not the most dangerous predators prowling the city, the strength of their numbers allowed them to carve out a sizable territory. After twenty years, wolfoids inhabited nearly every apartment complex, save for Roma. Exploratory forays to the despised complex revealed a single unsealed entrance via the skylight windows on the roof. However, once anyone entered the complex, the security robots and drone swarms prevented the intruder from ever exiting, upon penalty of death. Unable to establish a foothold, the wolfoids still found a use for Roma. Unrepentant lawbreakers, wife beaters, oath breakers, trespassers, deviants, and outsiders alike were cast into Roma to a life of exile. The wolfoids established a small outpost atop the apartment building to hold captives prior to their sentencing.

For the first inmates, a horrific death was almost guaranteed; biogs freely roamed the halls along with other mutated monstrosities. Over the course of the next decade, the strongest prisoners beat the odds. They banded together for mutual defense, growing their ranks by sheltering newly incarcerated wolfoid, human, and cyborg criminals. The ragtag group grew large enough to catch the attention of the artificial intelligences, Juno and Mars, who hoped to use the lifeforms in their war against Orcus. But as the number of convicts swelled, the artificial gods once again began to quarrel. After pushing the biogs back into the lower floors, the inmates split into two factions, one dedicated to each god, incessantly warring over turf.

At the present time, the rivalry between the A.I.s is still in full force. The adherents of Juno and Mars beef

over territorial borders and compete to recruit new prisoners. Though biogs occasionally find their way into the upper floors, they are mostly relegated to the lower levels. Orcus has fortified the entrances to his lower level domain. Little is known of what goes on within his stronghold; the other artificial gods believe without a doubt that the underhanded A.I. plots a murderous offensive and soon.

## LIFE ON THE INSIDE

No one has ever escaped from Roma Complex. The hover drones guarding the exterior respond to any attempts to breach the building's walls with extreme violence. On the inside, robots maintain Roma's original security protocols: Firearms and advanced weaponry are strictly prohibited; No flash photography; No outside food or beverages. The only weapons inmates can carry are of the replicated Roman-era. Security robots still patrol the halls of the upper apartment floors though the ratio of robots to inmates is woefully low. There is a 1 in 10 chance that the security robots show up 1d3 rounds after a fight breaks out. The security robots were programmed with non-lethal responses, intended to prevent sports riots from breaking out. When the robots enter combat, they spray pepper gas, shoot rubber bullets, and electroshock violent suspects. Once all combatants have been incapacitated or pacified, the security robots handcuff the detainees and wander off. In the olden times, human security officers would later arrive to process the detainees, but that no longer happens. After the security robots depart, wandering mutants or rival gang members might return to pick off the bound or incapacitated.

Two major gangs, the Junoans and the Martians, rule the upper floors. The artificial intelligences provide their followers with replicated food, clothing, and armaments all in the manner of ancient Rome. The gang members feel intense loyalty to their artificial intelligences, revering them as deities and following their dictates. For all their insistence to the contrary, the artificial deities have similar beliefs. Each wishes to extend their territory, consolidate power, and eventually take over the *Warden's* mainframe. The warring A.I.s differ on their approach to Orcus. Juno believes the deposed god should be kept in check with an overwhelming display of power and kept alive to suffer. Mars wishes to consolidate its forces and storm the lower floors to stamp out Orcus once and for all.

The upper floors of the building are divided almost equally with Junoans (occupying the north ends) and

Martians (the south) though they all consider themselves Romans. The tribal gangs boast nearly 200 members each, comprised of wofoids (79%) and their slaves: mutated humanoids (15%), other mutated creatures (5%), and true humans or cyborgs (1%). Humans do not last long among the Roman tribes because wofoids consider human hands a great delicacy. Any living humans encountered are most likely amputees.

After months of peace, tensions run high between the Junoans and Martians. A small skirmish could spark all out war. Territorial boundaries are marked by graffiti on the walls of every upper floor. Contested areas are covered in the overlapping tags depicting symbols of the gang's deity. The symbol of Juno is the peacock. A circle with an arrow emerging at a forty-five degree angle represents Mars (♂).

Juno, wife to Jupiter and queen of the gods, favors female followers. As a consequence, the majority of the Junoans are female. Junoans, male and female alike, dress in stolas of red, yellow, and blue hues, sometimes incorporating peacock feathers into their garb. The warriors among them wear simple tunics and goatskin cloaks cinched at the waist so they can move silently and attack quickly with short spear and javelin.

Martians are most recognizable for their crimson tunics, breastplates and plumed helms. As the god of war, Mars demands his followers be versant with many weapons. Martian legionnaires primarily fight with a short sword, called a gladius, and full body shield though they must each learn the disciplines of the pilum, pugio, and hasta. The Martian military ranks are staffed entirely by the male members of their clan.

---

## STATUS AND REPUTATION

---

Once the player characters enter Roma, they need to learn to live by a different set of rules to survive. Inmates usually travel in packs consisting of a single leader and 4-8 followers, a mix of warriors, mates, and slaves. The leader is the largest and most aggressive member of the pack and often wears a unique crest, cloak, or other affectation to display their status. The other inmates will assume the player characters are a pack if they are seen traveling together.

Status and reputation are very important to prison culture. Inmates must maintain an aggressive, ruthless façade at all times. Displaying the slightest amount of weakness is an invitation to be attacked—even by one's own allies. Until the adventurers build up a modicum of a "rep", they can expect to be bullied and confronted

by other packs of inmates. The pack with the highest rep becomes the de facto commander of each camp, i.e. the Junoans or Martians. Ultimately, the A.I.s are the true masters, pulling all the strings from behind the scenes, but it may take time for the adventurers to realize the Roman gods are actually artificial intelligences.

Status is earned several ways. Prowess on the battlefield is highly regarded by both Junoans and Martians. A pack raises its status whenever it defeats another pack. Of course, wholesale slaughter leaves no witnesses. If no one lives to tell the tale, the victory does not increase status. For this reason, it is rare for a pack to completely eliminate another.

Battle status can also be won in the Colosseum. The new Romans still enjoy the spectacle of blood sport. Every week, the gangs of Juno and Mars put aside their territorial disputes to compete in the arena. The games consist of gladiator battles, fights with mutated animals, and executions of traitors and incorrigible personages. Gladiators are generally slaves handpicked by pack leaders to bring glory to their god, but anyone is welcome to put their life on the line to gain glory.

There are no hard and fast rules to determine the effects of status and reputation. The referee should make a judgment call on how status changes the perceptions of non-player characters."

---

## MAJOR CHARACTERS

---

As the player characters travel through Roma Complex, they will discover the building itself has a personality, or rather, multiple personalities. In most areas, the artificial intelligences can see what the player characters are doing via security cameras. Each have their own desires and goals and may choose to help or hinder the player characters as they see fit, e.g. locking or unlocking doors, turning lights on an off, summoning security robots. The artificial intelligences may sometimes be at cross-purposes in which case they either lock each other out of the building controls, or activate and deactivate them in a loop. Player characters can communicate directly with A.I.s at computer terminals.

- **Juno** is an artificial intelligence that identifies itself as queen of the Roman gods, protector and special counselor of Roma. Juno can influence Roma's automated controls on Floors III through V. The A.I. wants to seize control of the upper floors and keep Orcus contained, but unharmed. Juno favors its female followers. Juno values the lives of true humans over all others.

- **Mars** is an artificial intelligence that believes it is the Roman god of war. Mars has the ability to manipulate building automation on Floors III through V. The artificial god yearns to unite the inmates into a single military force to exterminate Orcus. Mars favors the character with the highest leadership potential. Mars preserves the lives of true humans over other followers. Mars was a security A.I. and his followers use red bands as markers of status.
- **Orcus** is an artificial intelligence that personifies the Roman god of the underworld. The A.I. has exclusive access to the building automation systems on Floor I. Orcus longs to escape its prison, exterminate the other members of the artificial pantheon, and take control of Starship Warden. Orcus is a silver-tongued negotiator. The A.I. will agree to any deal with the player characters to secure its freedom although it will break any promises after its escape. Orcus was a medical A.I., and has converted the hospital in the complex into his ‘flesh vats’.

In addition to the unseen intelligences lurking behind the scenes, a number of other characters present challenges and opportunities to the player characters:

- **Quartermaster Bledig** is the prison warden and commander of the wolfoid outpost atop the roof of Roma Complex. The quartermaster controls all access to the rooftop entrance, maintains a logbook of incoming prisoners, and fortifies the outpost with a contingent of 45 wolfoid guards. The quartermaster is not above turning a profit. He can be bribed to deliver messages to and from the outside world. Bledig also buys, sells, and trades items with inmates.
- **Romulus** is a hotheaded wolfoid centurion that has garnered a large following among the Martians. Romulus wears battle-scarred armor and a transverse crest of red and white feathers on his helm. The wolfoid and his entourage spend their days raiding Junoan territory and inflaming the bloodlust of his fellow Martians. Other Martian war chiefs vying for his position of social status keep Romulus in check. Romulus befriends player characters who score battle victories against Junoans.
- **Remus**, a soft-spoken Junoan spearman, is the twin brother of Romulus. The wolfoid wears feminine garb and takes hormone injections to appear more womanlike, thus garnering more of Juno’s favors. Remus walks with a deliberate, regal deportment

with a headdress adorned with peacock feathers. On the battlefield, Remus attacks, dervish-like, with his long spear. There is no greater warrior among the Junoans. Remus will reward player characters for information on or attacks against Romulus and the Martians.

- **Vacsok**, a diminutive, bearded, half-man, half-machine, is a member of the reclusive cyborg enclave. The man-machines care little for the dramatic conflicts of Roma’s warring A.I.s. Cyborgs prefer to pursue their artistic and intellectual pursuits in seclusion. As the oldest member of the enclave, Vacsok has become the group’s de facto leader in that the others often defer to his wisdom. Vacsok has little interest in the player characters, but may be willing to give information in exchange for scavenged electronics or other valuable resources.

## EXPLORING ROMA

Once the party enters Roma Complex, they will discover there is no obvious way out. The adventure becomes a matter of staying alive long enough to escape the prison. The referee should invent a compelling reason for the player characters to enter the prison—ideally by their own choice—or use one of the ideas below:

- **Captured by Wolfoids:** The adventurers are defeated by wolfoids in another area of Epsilon City or one of the included adventures. Rather than outright slaying the defeated player characters, the wolfoids tend their wounds and toss them into Roma Complex.
- **Secret Mission:** Should the party befriend the wolfoids, one of their leaders recruits the group for a secret mission. The Roma Complex’s warden reports a prisoner has been spotted wearing a blue and red command color band. The wolfoid leader wants the group to pretend to be prisoners and retrieve the band (held by the Martian leader). Of course, once the color band is retrieved and relayed up to the skylight, the wolfoids double cross the adventurers and open fire.
- **Cyborg Quest:** Players who created characters before the release of Epsilon City may be interested in using the new cyborg accessory rules. Rumors of a thriving cyborg enclave find their way to the adventurers. The enclave possesses the technology to install cybernetic enhancements though the service comes at a high price.

Encounters are determined randomly while exploring Roma due to its size. Inmate warbands and roving mutations make exploration difficult (though not every encounter need result in combat.) After every thirty minutes in Roma, it is necessary for the referee to roll a die to determine if the player characters have an encounter with the wolfoids or other mutations. Roll a six-sided die; a 5 or 6 results in a run-in with one of the critters on the “Roving Mutations” table. Then, the referee rolls another six-sided die to determine the distance to the creature in yards. Check for surprise on roll of 1.

Roma Complex is littered with hidden treasures. Whenever the player characters emerge victorious from battle, roll once on the “Treasure Item” table. Most listed items are detailed in the core rulebook (MA, p.6-7, pp.28-29 in the Goodman Games edition). All techno-

logical items have a 20% chance of being broken when found. A group of wolfoids or other sentient creatures will also have 1d3 souvenir cups (see next section).

Scavenging is a common pastime for the resource-strapped denizens of Roma. Every room on the map potentially has useful items stashed away. There is a 5% chance of finding a treasure when the adventurers search a room (5 minutes for a small room, 15 minutes for a large room). Some doors are secured by electronic locks (as indicated on map), and can only be opened with the proper color band. A 3” x 8” rectangle next to the door displays the color of the band required for access. Searching these secure rooms almost always yields a treasure. Roll three times on the “Treasure Item” table.

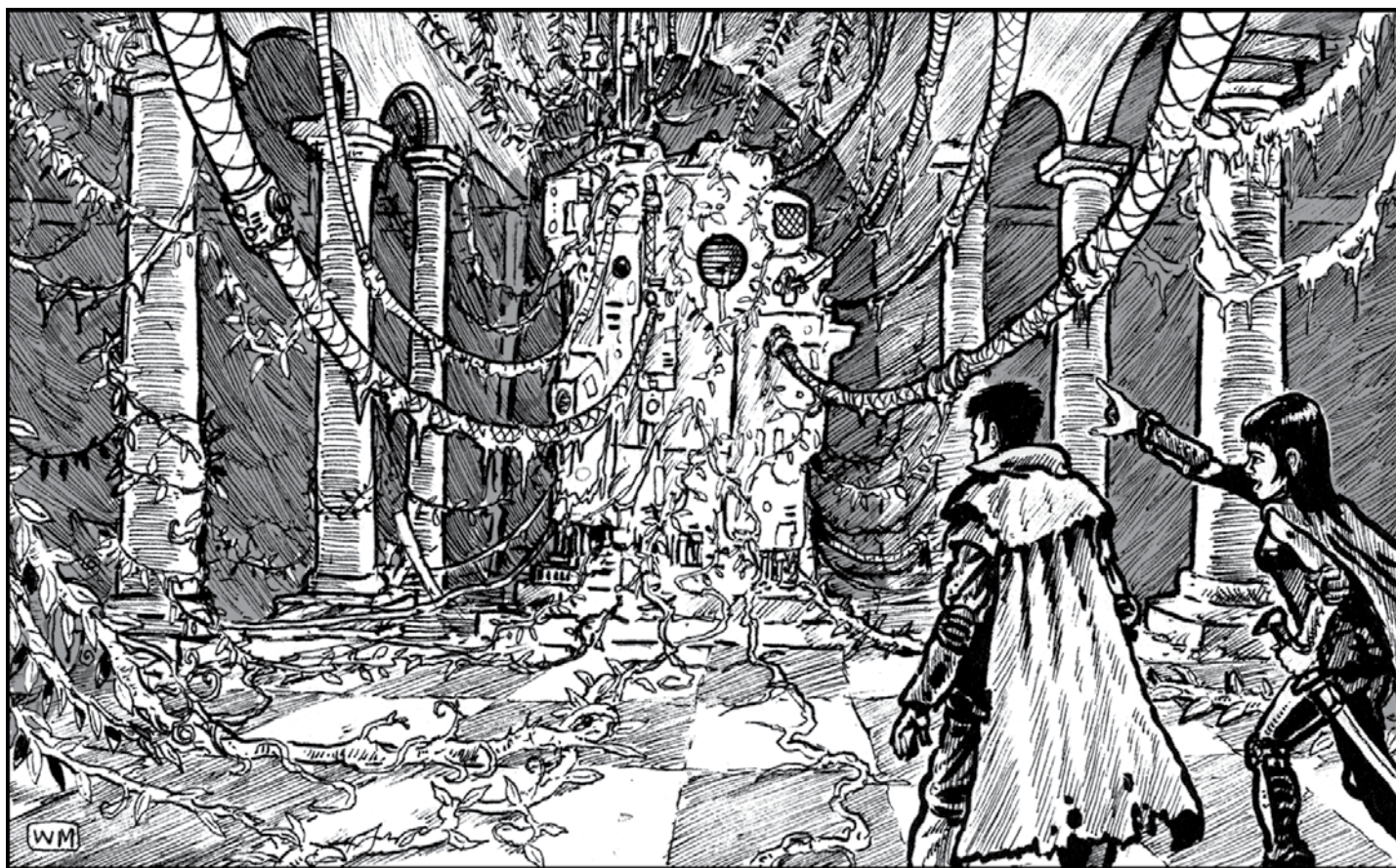

**TABLE 5-1: ROVING MUTATIONS TABLE**

| D20   | FLOOR III/IV         | FLOOR II             | FLOOR I   |
|-------|----------------------|----------------------|-----------|
| 1     | Black one            | Biog                 | Biog      |
| 2     | Blood bird           | Blood bird           |           |
| 3     | Death growth         | Dark fungus          |           |
| 4     | Deer                 | Death growth         |           |
| 5     | Hisser               | Deer                 |           |
| 6     | Humanoid #5          | Hisser               |           |
| 7     | Monkey pig           | Humanoid #5          |           |
| 8     | Roman wolfoid (Juno) | Monkey pig           |           |
| 9     |                      | Organ rat            |           |
| 10    |                      | Roman wolfoid (Juno) |           |
| 11    |                      |                      |           |
| 12    |                      |                      |           |
| 13    |                      |                      |           |
| 14    |                      |                      |           |
| 15    |                      |                      |           |
| 16    | Security Robot       | Security Robot       | Organ rat |
| 17    | Singing vine         | Security Robot       |           |
| 18    |                      |                      |           |
| 19-20 | Winger biter         | Winged biter         | Megabiog  |

**TABLE 5-2: TREASURE ITEM TABLE**

|       |                                      |    |                              |
|-------|--------------------------------------|----|------------------------------|
| d100  | Contents                             | 85 | Medical hand analyzer        |
| 1-49  | Nothing                              | 86 | Sonic torch                  |
| 50-59 | Food (5% poisoned, strength 3d6)     | 87 | Atomic torch                 |
| 60-69 | Water (5% poisoned, strength 3d6)    | 88 | Laser torch                  |
| 70-74 | Shiv (as dagger)                     | 89 | Medical Analyzer hand unit   |
| 75    | 1d3 souvenir cups                    | 90 | Infrared goggles             |
| 76    | Radioactive material (intensity 3d6) | 91 | Chemical defoliant           |
| 77    | Random mutated substance (MA, pg 21) | 92 | Chemical acid                |
| 78    | Paralysis dart (1 shot)              | 93 | Chemical flammable           |
| 79    | Solar cell                           | 94 | Portable energy lamp         |
| 80    | Chemical cell                        | 95 | Sound elimination headphones |
| 81    | Geiger counter                       | 96 | Brown color band             |
| 82    | Ecology life analyzer hand unit      | 97 | White color band             |
| 83    | Engineering system hand unit         | 98 | Gray color band              |
| 84    | Sonic reducer (melts duraplastic)    | 99 | Green color band             |
|       |                                      | 00 | Red color band               |

## CURRENCY & TRADE

---

The most sought after item within Roma are antique Colosseum souvenir cups. Due to the idiosyncratic programming of the security robots, outside food and beverages are prohibited within the entire complex. The robots may search inmates' belongings at any time and confiscate all their food and water. However, the robots' subroutines do not permit them to search inside the cups. The inmates exploit this quirk to transport food, water, and any other items that fit into the jumbo-sized cups. In the absence of a monetary system, souvenir cups have become a currency that can be exchanged for goods. Whenever the adventurers find a souvenir cup, there is also a chance that another item is hidden inside of it. Roll on the "Treasure Item" table every time one is opened.

The Junoans and Martians both accept souvenir cups as payment for goods: food or water, 2-3 cups; a simple melee weapon such as a shiv, 5 cups; or a gladius, 10 cups. Trading posts are located at the base camps offering other goods and services: safe sleeping space for 1 night, 2 cups; a broken technological item, 5-7 cups; or a technological item, 10-15 cups. The party should take care to conceal their hoard of souvenir cups. An envious wolfoid (even an ally) might stalk the group and rob them.

## SHRINES

---

The artificial intelligences, Juno, Mars, and Orcus, are revered as deities by their followers. The A.I.s' shrines are spread out throughout the complex protected behind security doors. A grey engineering colorband is required to open the door. At each shrine, composite marble columns support a dome built from tufa and pumice. Within the rotunda, patinaed holobank clusters hum softly to themselves blinking with tiny varicolored lights beneath a mantle of corroding metal and overgrowth. Computer terminal located in each shrine can be used to communicate directly with the tempestuous A.I.s with a keyboard or microphone.

## ESCAPING ROMA

---

According to popular legend, no one has ever escaped from Roma Complex. However, inmates have been lost without a trace numerous times. Who is to say the prisoners did not escape and flee Epsilon City

never to return? For the adventurers' part, they must execute their own escape plan from Roma. There is no single way to solve this dilemma. Here are several scenarios that might possibly play out:

- **Pact with Juno or Mars:** Knowing Orcus is safely contained below, the A.I.s of the upper floors war over control of territory and followers. Player characters can make contact with the artificial deities through a computer console. A god can disable the security drone perimeter around the complex, but will not agree to do so unless all of its rivals' shrines have been disabled on every floor (i.e. burn all the other shrines in the complex).
- **Pact with Orcus:** Several computer terminals on Floor II can be used to contact Orcus who is trapped on the bottom floor. The A.I. will strike a bargain with the party: Reestablish its network connection by installing patch cables in at least one main datalink panel on Floor II through IV, and Orcus will disable the security drone perimeter to allow the group to escape. Orcus is true to his word, but once free the artificial intelligence will displace the Starship Warden's main A.I. causing issues for the adventurers later.
- **Maintenance tunnel:** A secured maintenance tunnel is located on the bottom floor of Roma Complex within Orcus' flesh vat room. With the proper access code, the tunnel can be opened and the player characters can crawl underneath the drone security perimeter to freedom. Vacsok of the cyborg enclave knows the location of the tunnel and will sell the access codes for the right price.

## APARTMENTS











---

Roma's accommodations were designed with an eye for showcasing ancient Roman architectural styles. The high ceilings of each floor are decorated with trompe l'oeil murals of a blue sky and a hidden lighting system that cycles through day and night. The apartments are constructed as free standing buildings 20' below the false sky. The porticos are tiled with marble and flanked by Doric columns. Wolfoids reside in the majority of the inhabited apartments. Their domiciles are easy to spot due to their customary habit of displaying monster or mutant animal hides. Each clan demonstrates their battle prowess by hanging the hides of defeated monsters over their front doors.



# ALPHA CITY ROMA COMPLEX

## LEGEND

-  Elevator
-  Stairs
-  Juno Shrine
-  Mars Shrine
-  Orcus Shrine
-  Maintenance Tunnel
-  Brown Access
-  Green Access
-  Grey Access
-  Red Access
-  White Access

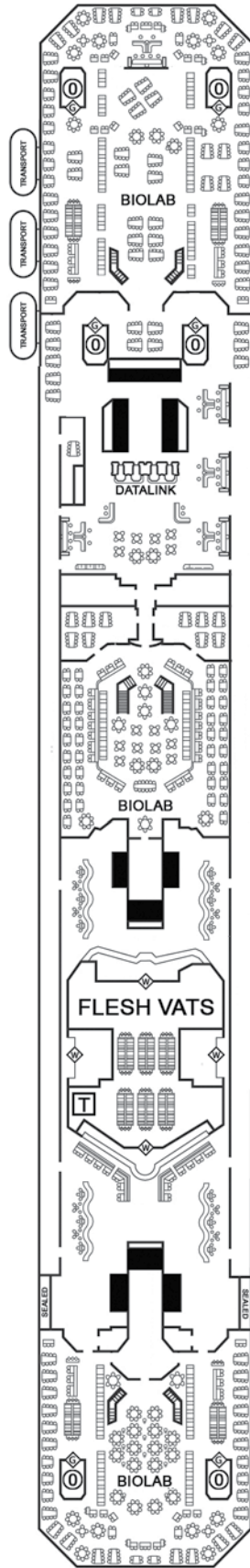

FLOOR I

ORCUS CONTROLLED

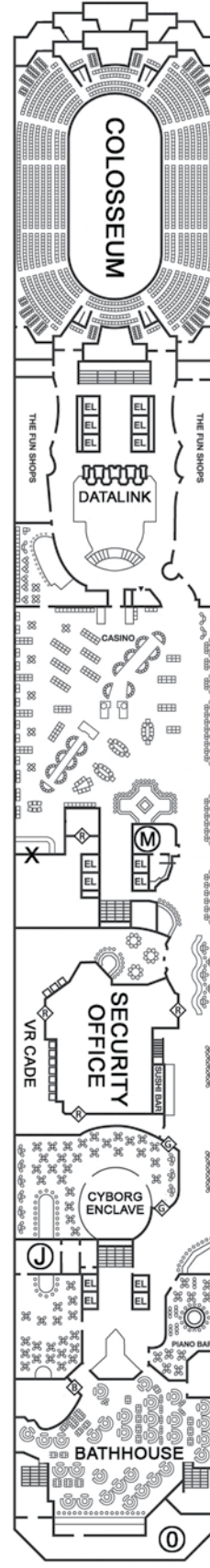

FLOOR II

CONTESTED

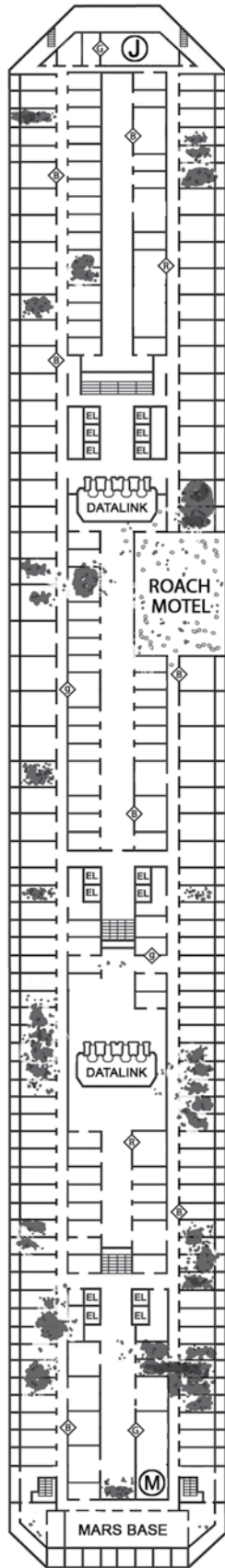

FLOOR III

JUNO CONTROLLED

CONTESTED

MARS CONTROLLED



FLOOR IV

JUNO CONTROLLED

CONTESTED

MARS CONTROLLED

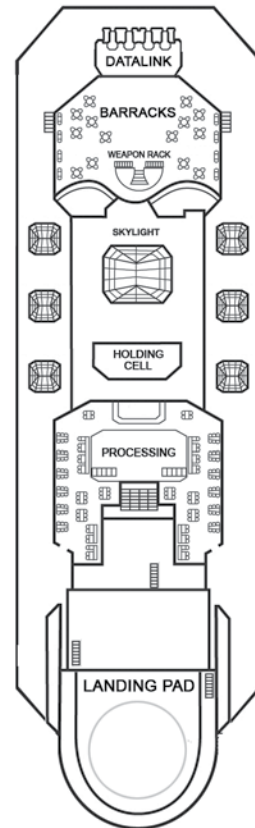

FLOOR V

Inside each apartment, a small *vestibulum* leads to a central atrium decorated with frescoes. A small fountain is centered under an artificial skylight that invokes the open-air layout of the ancient Roman *domus*. The floors are decorated with traditional mosaic patterns. Several *cubiculum*s are attached to the atrium. These square rooms can be configured as bedrooms, studies, or living rooms. Vision screens are disguised to tastefully blend in with tile work on the walls, but most are broken. Grates near the ceiling can be used to access to the ventilation system.

The apartments are occupied closer to the north and south extremities of the upper floors. Martians and Junoans hotly contest the middle areas of each floor. The apartments in those areas are often trashed, abandoned, or ruined. The plants in the atrium overgrow the entire floor plan. Splotches of black mold darken the walls. Fixtures and building materials have been stripped to make repairs other areas. Exploration is dangerous as hideous, mutated creatures often lurk in these darkened vestibules.

---

## STAIRS AND ELEVATORS

---

Travelling between floors in Roma is accomplished in three ways. At least two stairways connect Floors II through IV. The stairs are decorated in a grandiose manner with travertine tile. A call button is located at the entrance to each stairwell. When pushed, an electric seat is summoned. The seat has up and down controls to travel from floor to floor. However, the seat makes a god-awful racket. There is an 80% chance the sound attracts a nearby creature; Roll on the “Roving Mutations” encounter table. The keyed stairwells on the Roma Complex map connect to the matching set of stairs on the adjacent floors with one exception. The stairwells to Floor I are filled with a strange solid translucent red material and are completely impassable.

Elevator banks are located at the north and south ends of each floor. Pressing the call button will open the doors of one elevator at every bank. Juno and Mars have locked out the elevators though. Hitting a floor button will not move the elevator between floors. At any given point, there is a 50/50 chance that either Juno or Mars controls the elevator. If the elevator’s occupants are affiliated with its rival, the A.I. may trap them by not opening the door, or employ other tricks such as sealing the door, sounding the alarm bell until a wandering monster approached, then opening the doors. Of

course, every elevator has an escape hatch that can be used to reach the elevator shaft, and from there, the ventilation system. Elevator shaft travel always triggers a random encounter; Roll on the Encounter table. Orcus has sealed the entrance of the first floor from the other side with a solid cube of duraplastic.

---

## VENTILLATION SYSTEM

---

Besides travelling between floors, player characters can also move laterally across a floor by way of the ventilation system. The system is laid out in a grid that travels up, down, or in cardinal directions. The severely damaged ducts are barely large enough for the average-sized human adult to crawl through. Numerous areas are impassible or on the verge of collapse. Combat in the ventilation system is very difficult since only the character closest to the foes will normally be able to attack. The shipmaster should quickly make the players understand that travel via ventilation ducts is a risky proposition.

To keep track of the party’s movement in the ventilation system, the judge has permission to photocopy the Roma Complex map. Draw the duct pathways lightly over it with a pencil. **Roll a six-sided die: 1-4 times to determine the directions the ducts go at each junction: 1 – North; 2 – South; 3 – East; 4 – West; 5 – Up; 6 – Down.** Ducts have grates every 20-50’. It is up to the discretion of the referee how far a section of duct goes before reaching another junction and incurring another roll. Use common sense to interpret the results. For example, when the party reaches the edge of a floor map, do not allow further travel in that direction. Multiple identical rolls count for a single direction. Each time a direction is taken, roll on the “Ventilation Event” table below. If at any point a mistake is made in the map, the shipmaster can rectify the situation by declaring that the ventilation duct collapses dumping everyone into the room below. Though the elevator to Floor I is sealed, it is possible to reach Orcus’ domain from the ventilation ducts.

**TABLE 5-3: VENTILATION EVENT TABLE**

| D20   | RESULT   |
|-------|--|
| 1-8   | No event.  |
| 9-10  | Impassible or dead-end.  |
| 11    | Duct collapses. Everyone falls into room below for 1d6 damage.   |
| 12    | Duct collapses. Everyone chutes to next floor down for 3d6 damage.   |
| 13    | Large scrubber bot blocks travel. PCs can either wait for it to pass (1 hour) or come up with another way to get passed it.  |
| 14    | Find a random technological item hidden in duct (MA, pg 21). Reroll large item results.  |
| 15    | Radioactive material (2d6+6 radiation intensity level) glows bright green.   |
| 16-20 | Roll on the “Roving Mutations” table. If the encountered creatures can fit, there is a 60% chance the creatures are in the duct. Otherwise, the creatures wander into the room below. Initially, there is a 2 in 6 chance of the mutation detecting the adventurers. Every minute after, there is a 1 in 6 chance of detection whereupon some calamity occurs. For example, the mutation attacks the ventilation duct, or the duct collapses dumping the party to the floor. |

### DATALINKS

On each floor, there are one or two reinforced datalink structures that house the floor’s network interconnections. These structures have locked sliding panels on each side. Next to each panel, a color rectangle, half grey and half red, can only be opened by someone who possesses both an engineering and a security colorband. Opening a panel reveals rat’s nest of wires and blinking green, yellow, and red lights. The wires hide a blue plate with a grid of round sockets, labeled 1 through 1000. Almost every socket has a wire connected. One panel on each datalink contains the “main panel”. The main panels are red and have 2 columns of 7”-wide octagonal sockets labeled. The leftmost sockets are labeled by row: I, II, III, IV. The rightmost sockets have a single label atop the column indicating the current floor. Thick bundles of rainbow-colored cable are connecting rows II, II, and IV to the current floor column.

When the adventurers enter Roma, the row I cable are disconnected at every datalink. The Floor V datalink also contains an uplink lever which is currently thrown to the OFF position.

### ENTRANCE TO THE APARTMENTS

The buildings in the immediate vicinity and the avenues leading to Roma Complex are curiously devoid of activity. The wolfoids avoid the imposing structure like they would a wounded member of the pack. The east and west lobby entrances are sealed with 10’ thick duralloy. All windows, balconies, and doors from the ground floor up are sealed with reinforced deck plating.

Security drones hover vigilantly in a matrix around the entire complex. Their number is nearly 1,000. The drones attack without warning any creature that attempts to breach the secured outer walls from outside or within. The drones won’t enter the complex through a wall breach; they guard the entrance until engineering robots arrive to cover the rupture. Similarly, the hover drones only pursue targets within a 100-meter radius of Roma Complex. A special hunter drone is sent to exterminate targets that move beyond the security perimeter.

The only means of peaceful ingress is through the wolfoid outpost on the roof. Several apartment transports are parked near the base of Roma Complex. The transports are programmed to fly directly to the roof. Each transport can comfortably hold 8 passengers.

**Poking above the lower buildings surrounding it, an enormous windowless, patchwork building exudes a dread tone. Metal plates are welded over every opening, door, and balcony on its five story tall surface. Beams of white light sear the ground in slow arcs from the roof. Countless hovering machines teem around the structure from top to bottom, floating in a precise geometric pattern. Their thousands of whirring anti-grav quadwings fill the air with the palpable menace one feels approaching a hive of angry bees. One thing is clear: you should keep your distance from this building.**

## FLOOR V – ROOF OUTPOST

---

The wolooids have established an outpost atop which consists of a squad of 45 wolooids and their wolooid commander, Quartermaster Bledig. The outpost maintains a barracks; an administration building for processing new prisoners; a weapon rack stocked with a protein disruptor rifle, a sonic metal disruptor, 6 laser pistols, 2 slug projectors, 40 heavy crossbows, 2 gas ejectors, 32 halberds, and 3 laser torches; and a holding cell for incoming prisoners.

Quartermaster Bledig is responsible for outpost operations. New prisoners are processed and then placed in the holding cell. They are disarmed, strip searched, and issued new clothing: a tunic. After 24 hours, Bledig sentences the prisoners and they are lowered into Roma Complex (Floor IV.1: Drop Zone) by a rope and pulley elevator over one of the skylights. The wolooids give the group a single *portable energy lamp*. The wolooids also have a bucket on a rope they use to pass items in and out of Roma Complex. The sky roof is the only point where Roma can be entered and exited without reprisal from the security robots.

Bledig and his two lieutenants possess red security bands.

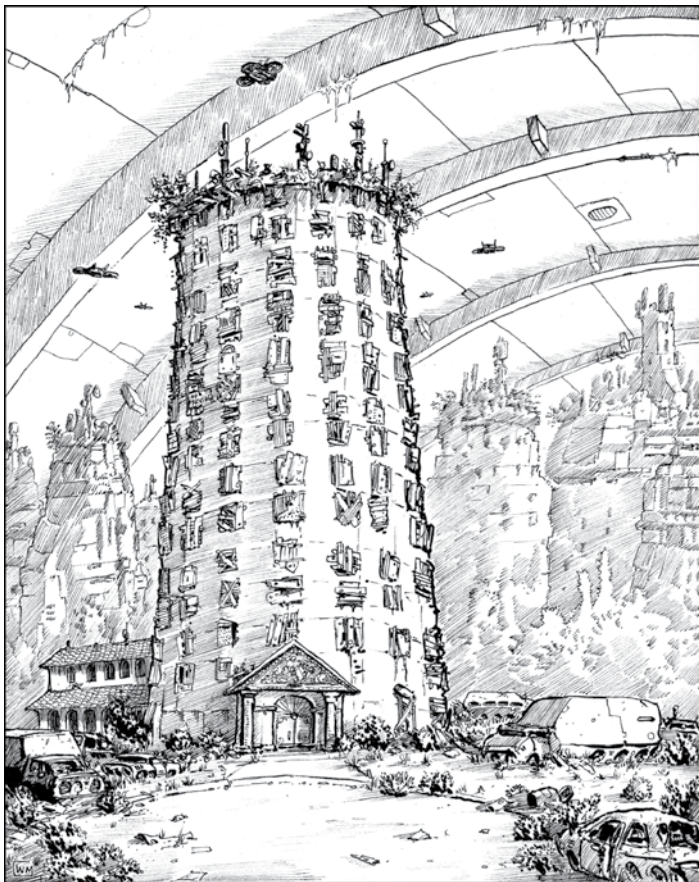

Player characters who visit the outpost as freemen are intercepted by the quartermaster and his guard at the landing pad. The wolooids are heavily armed and will respond to any aggression. Bledig is not entirely unreasonable. If the group arrives with a good reason for their presence and agrees to be disarmed, the quartermaster allows them a brief visit. The wily wolooid might even offer the visitors a job such as entering Roma and bringing back an item or prisoner. Of course, the party must agree to enter the complex with nothing but a tunic (concealed cyborg implants may escape their notice, however). The quartermaster will not free the party once they have entered Roma.

**Your cell door squeals open. “Get up,” growls a black-furred wolooid. “Time to go.” Guards with halberds surround you and prod you toward a skylight with a large wicker basket tied to a heavy wire and pulley. As you are loaded into the elevator, the wolooid commander steps onto a soapbox and clears his throat. “For crimes against the wolooid code, I pronounce you guilty, guilty, GUILTY. I hereby sentence you to 3 life sentences to be served consecutively in Roma Complex.” A guard drops a foot-long metal tube into the basket. The elevator lurches and slowly descends into a lightless void.**

**Grim-faced wolooids peer down from open skylights, pointing rifles at the empty floor 50’ below. The basket strikes the ground with a resounding metallic thud. The damp air reeks of mold. The wolooid commander shouts after you. “May the Wolf Mother have mercy on your souls.” The skylights slam shut one by one as you hear the clanging of heavy padlocks being put back in place.**

## FLOOR IV – PENTHOUSE APARTMENTS

---

The penthouse floor once boasted the most opulent housing in Roma Complex. Outer rooms had floor to ceiling windows with commanding views of Epsilon City. The crumbling facades now expose their rebar skeletons. The map indicates whether a territory is controlled by an A.I. or is contested. There is a 30% chance in A.I.-controlled areas for a room to house a group of its followers, i.e. Junoan or Martian wolooids. There is also a 50% chance that nearby followers will hear the sounds of battle and join the fray in 1d3 rounds. In the contested area, only 10% of the rooms are inhabited, and there is only a 5% chance of a wandering monster joining a fight.

The lights and all light switches on the entire floor are disabled as Juno and Mars are currently fighting over the floor's automation controls. Never forget that the building has a personality and it is quite schizophrenic. The entire complex's automated systems are controlled alternately by two warring A.I.s that may be hostile or friendly to the group. Lights may turn on in succession to lead the group in a direction, or an automatic door may suddenly slam shut on an adventurer causing damage. Juno and Mars will take whatever steps they deem necessary to increase their individual power.

---

## FLOOR IV.1 – DROP ZONE

---

The prisoners are lowered into this atrium from the skylights 50' above. Weeds grow between the uneven travertine floor tiles. Creeper vines snake up the dingy marble walls. The lighting on this floor is currently disabled though dim light filters in from the skylights. The cylinder the wolfoids tossed into the elevator basket is a portable energy lamp. A cone of bright light emits from one end of the cylinder after pressing a red button. The atrium has been stripped of all furnishings yielding nothing to use as an improvised weapon. The halls beyond the atrium loom as black and silent as death.

The party will have their first encounter a few minutes after being dumped in the drop zone. Mars-aligned Roman wolfoids are waiting to ambush the new inmates. The wolfoids are hostile and get a surprise round of attack. If the party loses some members or willingly surrenders, the wolfoids agree to take the party prisoner. The captives are bound and led south toward the Martian base (Floor III.1). Roll for random encounters on the "Roving Mutations" table en route. The captive characters may have a chance to escape if a mutated creature attack the Martians, or the rival Junoans might stage an ambush of their own and take the captives back to their own camp (Floor IV.2).

---

## FLOOR IV.2 – JUNO BASE

---

The entrance of this wolfoid stronghold is heavily fortified with a retinue of 15 Roman wolfoids. A spiked palisade wall on wheels is locked in place barring entry. Remus, the dominant Junoan tribal lord, holds the camp in his grip at this time (see "Major Characters" section for more information). If the player characters arrive as captives, the chieftain offers freedom in exchange for fealty. Remus will supply friendly adven-

turers with long spears and torches. Enemies and prisoners of war are used as combatants at the biweekly Colosseum games.

The adventurers can build their status within the Junoan camp by defeating Martians, providing information about Martian troop movements, and exterminating mutations that threaten Junoan territory. The Junoans will reward the players with souvenir cups and allow them to barter at their trading post (see "Currency & Trade" section).

---

## FLOOR III – MAIN APARTMENTS

---

The main floor apartments are more staid than the luxury dwellings on the floor above. The cramped quarters here have fared much worse from the constant skirmishes the Junoan and Martian. Many rooms are either boarded up or completely filled with refuse, making them impassible. The map indicates whether a territory is controlled by an A.I. or is contested. There is a 30% chance in A.I.-controlled areas for a room to house a group of its followers, i.e. Junoan or Martian wolfoids. There is also a 50% chance that nearby followers will hear the sounds of battle and join the fray in 1d3 rounds. In the contested area, only 10% of the rooms are inhabited, and there is a 5% chance of a random roving mutation joining a fight.

There is a 15% chance of finding a band, after a prolonged search of the debris. Roll % dice: 1-40: brown, 41-65, green, 66-79, gray, 80-91, white, 92-95 red, and 96-00 other (specialized or GM's discretion).

---

## FLOOR III.1 – ROACH MOTEL

---

An aggressive new breed of mutated cockroaches has taken hold on this floor. The splotchy black and yellow roaches have mandibles that drip with a caustic acid capable of dissolving metal. They have eaten through the walls of several apartments to create a larger lair chamber. Harvested metal is used to construct clusters of ferrous crystalline structures that serve as a hive. The insects move by crawling along the pheromone-scented trails left by colony members. However, the creatures fly into a vicious swarm when they sense sudden movement or a threat to the colony.

This strain has reached a higher level of socialization than any other roachid species. Their social caste is comprised of a large number of soldier-gatherers and hive workers that serve a single queen-king that repro-

duces parthenogenetically. The hermaphroditic insect leader possesses limited telepathic abilities. Within a 15' radius, the insectoid ruler can project two simple thoughts to any creature, "grovel" and "obey", and inflict *mental paralysis* on those that defy its will.

When the player characters enter the center of the roaches' domain (as marked on the map), read the text below.

**A jagged hole with corroded edges has been eaten through the wall here. The metal support beams beneath the faux Roman exteriors are blackened and pitted. In the chamber beyond, a cluster of polished, ebony crystals over 10' in height jut from the floor. Every surface of the chamber teams with hordes of crawling black and yellow cockroaches, 3-4" in length.**

---

### FLOOR III.2 – MARS BASE

---

The halls leading up to this base camp is decorated with severed wolfoid heads, Junoan victims of Martian territorial conquest. A squad of 15 Roman wolfoids, adorned in red tunics and centurion armor, stand guard at the gate. Romulus, tribal leader of the Martians, holds power here (see "Major Characters" section for more information). If the player characters arrive as prisoners, the war chief claims them as slaves. However, they may earn their freedom by joining his military ranks. Romulus outfits allies with body-length red shields and short spears. Enemies are held captive, and then forced into combat at the biweekly Colosseum games.

The player characters can increase their status among the Marians by defeating Junoans, delivering their severed heads to camp, and killing mutations within Mars' territory. Romulus rewards conquest with souvenir cups and access to the Martian trading post (see "Currency & Trade" section). The first time the players characters return victorious from battle, the wolfoids hold a great feast that includes a long serving dish piled with steaming human hands (a wolfoid delicacy).

---

### FLOOR II – GALLERIA

---

At one time, the galleria was the central attraction of Roma Complex. In addition to the hundreds of residents, throngs of tourists from Epsilon City and beyond flocked to the galleria's shops and piazzas. The galleria also had a very active nightlife filled with bars, restaurants, and nightclubs though the Colosseum was

largest attraction. The indoor arena boasted concerts, plays, and reenactments of the grand spectacles of the ancient Roman era. Nowadays, everywhere save the Colosseum is a bitter no man's land.

---

### FLOOR II.1 – COLOSSEUM

---

Though the galleria floor knows no master, the Colosseum has been spared by a pact between the Junoans and Martians. Though the Colosseum has changed hands several times, the games have continued almost unabated for nearly three centuries. It is as if the weathered structure embodies an ageless spirit of competition that enflames the passions of man and mutant alike.

The Colosseum is built of three circular stages surrounded by arches. The massive amphitheater was built to accommodate tens of thousands of spectators though time and war have decimated much of the former seating. Under the main floor is a labyrinth of rooms, passages, and cages packed with mutated beasts. A staff of 100 neutral Roman wolfoids, who have dedicated their lives to preserving the games, maintain and protect the premises.

Every two weeks, the followers of Juno and Mars set aside their differences for a day to enjoy the Colosseum games. The schedule of events varies from week to week. The ceremony begins an elaborate procession of all combatants and participants parading the arena; next, a torch relay race between the wolfoid factions. The followers of Juno are bedecked in blue clothing and Mars in red. Then, the gladiatorial contests begin.

Gladiators are slaves or prisoners of war though wolfoid allies can choose to enter the gladiatorial arena as champions of their deity. Prevailing in gladiatorial combat confers quite a bit of status. Slaves who survive the entire day are often granted their freedom. The combats alternate through different forms; Roll a d10: (1) *mano a mano* battles with melee weapons such as (2) trident and net, (3) gladius, (4) spear, or (5) dagger; (6) group gladiatorial battles—sometimes while (7) blind-folded; (8) solo fighters versus mutations; (9) group battle against mutations; (10) mounted combat by gladiators on eight-legged horses. Between every few battles, other events occur such as chariot races, musical performances, and executions.

## FLOOR II.2 – SECURITY OFFICE

---

This building is the base of all security operations in Roma Complex. When not on patrol, security robots return to the office for repairs and battery recharges. At any given time, 20-30 robots are on hand. The security robots will not attack a group if at least one member wears a red colorband. The robot recharging stations can also be used to refill hydrogen energy cells.

A floor-to-ceiling video wall still displays live video footage from the hidden security cameras that are still functional (roughly 60%). A security console has buttons labeled for each floor on the left. At the center, a 20x50 grid of blue buttons can be pressed to activate individual cameras on each floor. A joystick on the right side of the console allows pan and zoom control of the video images.

An equipment locker with a PIN pad gathers dust on the north wall. The locker contains a security hand unit, a paralysis rod, 2 paralysis darts, and a portable hand dart charger.

The wastebasket next to the security console contains a crumbled-up piece of yellowed paper. It contains the access code to the equipment locker: 5555.

## FLOOR II.3 – CYBORG ENCLAVE

---

Eleven cyborgs have secreted themselves in this area. Green color bands secure the entrances to this area, and a security camera and call button have been placed at each door. The reclusive cyborgs shun the outside world preferring to explore their inner worlds, intellectual pursuits, and artistic endeavors. Uninvited guests will be greeted by a full assault by all eleven cyborgs though they will not pursue the party beyond their security doors.

Their leader, Vacsok, is an accomplished painter, likely a genetic artifact of his true human stock. He has a scraggly beard, measures barely over 5' tall,

and has two glowing vacuum tubes in place of eyes. Vacsok reeks of bathtub synthanol that he both drinks and uses to thin his paints. If the adventurers press the call button, it is Vacsok who will eventually answer. The (probably drunk) cyborg demands to know who is culpable for this intrusion of privacy, and is generally antagonistic to callers. He is willing to trade information for technological items, broken or otherwise. The cyborgs do not accept souvenir cups as tender. See the “Major Characters” section for more information. Vacsok possesses a green band, allowing him to control the doors. He has several extras secured away in his quarters, but is reluctant to part with them: they are loaned to other cyborgs to help protect the enclave.

The cyborg enclave possesses the equipment (a surgical suite) required to install cybernetic enhancements, and may be willing to help player characters become cyborgs themselves. The adventurers would need to have established a strong rapport with the enclave first by helping them with tasks around greater Roma or delivering large quantities of technological items. The cyborgs' equipment can only be used to install devices of 4 cyborg points or less; see “Cyborg Accessory” for details. The same surgical suite can also be used to patch up characters who have suffered major injuries, though the cyborgs are like to provide free ‘enhancements’ to anyone they help.

## FLOOR II.4 – BATHHOUSE

---

Thick steam fills the air making it difficult to see further than 10'. Dozens of tiled pools are spread across the entire area, filled with opaque green water. Death growth floats on the water's surface as clumps of greyish matter. Two pools have shiny boxes floating beneath the surface, but these are only broken security robots. Warm-blooded creatures that touch any of the pools will catch a face-full of deadly spores.

The lockers in the bathhouse's changing rooms (if they are forced open) contain personal effects of residents killed here in the disaster. Forcing open the lockers requires an axe or crowbar. There are seven



color bands along with rotting fragments of clothing and footwear, personal identifications, and small broken gadgets – watches, personal communicators, and other junk. Smashing open a locker requires about 15 minutes.

Roll on the following table to determine the bands found, Roll % dice: 1-40: brown, 41-65, green, 66-79, gray, 80-91, white, 92-95 red, and 96-00 other (specialized or GM's discretion).

## FLOOR II.4 – SHOPPING & ENTERTAINMENT

The galleria is filled with shops and amusements that are now mostly unrecognizable. The items listed below describe a few of the minor destinations marked on the map:

- **II.4.1 – THE FUN SHOPS:** This area was once filled with gift shops, clothing stores, tanning salons, and piercing booths among others. Almost all the merchandise has been stolen. The shops have been vandalized and their windows smashed. Several worthless items can be found by digging through the detritus, e.g. a black mouse-eared hat. If the party spends more than thirty minutes in the area, they will discover a brightly lit gladiator gift shop filled with brand-new suits are armor and weapons. However, this is only an illusion generated by a ravenous dark fungus to lure in its prey. Touching any of the armor or weapons causes 10 die of damage.
- **II.4.2 – VR-CADE:** A row of virtual reality booths are arranged in a row. Only one of them still functions. The booth contains a helmet and pair of gloves. Putting them on transports the wearer to a black void with a luminescent blue grid for a floor. Three doors, labeled “Game Town”, “Sexy Town”, and “Roma Virtual Tour”, are lined up before the wearer. The portal to “Game Town” leads to a garishly colored world populated by evil turtles and angry mushrooms. The portal to “Sexy Town” causes an electrical short that inflicts a *mental blast* on the wearer for 3 die damage and fries the booth's circuits, irreparably destroying the machine. The portal to “Roma Virtual Tour” leads to a realistic simulation of Roma Complex before the catastrophe. The visitor can use the simulation to learn more about Roma Complex. Travelling to Floor I in the virtual world reveals a welcome center, a sprawling park, and well-manicured gardens. The ventilation system

can also be mapped in the virtual world without the risk of actual harm. In any case, the referee should continue to roll for encounters with “Roving Mutations” while the player character is in cyberspace.

- **II.4.2 – CASINO:** The gaming tables are now long gone. The area is overgrown with thick vegetation. However, if this area is visited from the virtual reality booth, it appears as a bustling casino with a cashier booth near the elevators. In the present, the X on the map to the southwest of the casino is covered by thick brambles, but in the past there was an open corridor leading to the rear entrance to the cashier's booth. Knowing the proper location of the door would allow the brambles can be hacked away to gain access. The cashier's booth hides a lockbox with a protein disruptor pistol inside.
- **II.4.4 – SUSHI BAR:** The stench of rotting fish permeates the air. The sushi bar replicator turns on at odd times and shoots raw tuna onto the ground behind the bar, attracting predators. Roll for on the “Roving mutation” table when the party comes within 20'.
- **II.4.5 – PIANO BAR:** Broken chairs are arranged around a piano, or what appears to the player characters to be a “odd-shaped, black technological machine 6' wide with a row of black and white buttons.” Every time a character touches a button, the referee should describe the painful sonic vibrations that rattle their ears and increase in pitch as they are pressed from left to right. Playing the piano always attracts a roving mutation.

## FLOOR I – UNDERWORLD

The bottom floor of Roma is the exclusive domain of Orcus. Lush gardens and parks were once hallmarks of this area though present visitors will immediately notice the stark change in décor. The marble tile and colonnades prevalent on the upper floors have been stripped away. The walls and floors over covered in a seamless, crimson duraplastic with a high gloss sheen. Every sharp corner has been smoothed and rounded. Orcus has retrofitted the entire floor to better accommodate its strange biologically augmented creations, the biogs.

All elevator shafts and stairways to Floor I are sealed with impassable and nearly indestructible duraplastic. The only way to infiltrate this floor is through the ven-

tilation ducts. Floor I is also constantly prowled by ravenous biogs. The referee should roll for “Roving Mutation” encounter every time the player characters enter a room (2 in 6 chance) and every 30 minutes of in-game time (1 in 6 chance). For every two rounds of combat, there is a 1 in 6 chance that another biog joins the fray.

---

## FLOOR I.1 – BIOLAB

---

Three large bio-experimentation laboratories are located at the north, center, and south of this floor. The biolabs are filled with beds, medical equipment, 2-3 medical robots, and hundreds of cryotubes. Each lab has 5 large manipulator arms that travel along the ceiling. Orcus can control these arms to manipulate equipment and grab creatures.

The doors to the Bio-Lab are controlled with white medical bands. While there are several lying on tables and desks in the Biolab,

Orcus has only releases enough biogs to protect the floor from attack. The majority of cryotubes contain hibernating biogs preserved for the A.I.’s eventual assault on the upper floors. The cryotubes have glass viewing windows where the biogs can be seen floating in pink liquid. Smashing a cryotube dumps the sleeping biog out, none too pleased to be awoken.

---

## FLOOR I.2 – FLESH VATS

---

Four vault doors requiring medical color bands for access protect the flesh vat facility at the center of the floor. The flesh vats are a new technology invented by Orcus. They are giant riveted tanks filled with a primordial slurry—20’ wide, 60’ long, and 20’ tall. The A.I. can synthesize 3-6 biological organisms at a time in each vat. The fetuses can be incubated at 5 times their normal growth rate. The majority of vats are dedicated to sequencing livestock to feed to the ravenous biogs lurking the halls.

In the southwest portion of this facility, a heavy trapdoor is set in the floor and locked with a security code (#1337). Entering the code opens the vault door. An steel ladder leads down to the maintenance subterranean tunnels which run east and west beneath Roma Complex. Vacsok of the cyborg enclave (Floor II.3) is the only person in Roma Complex with the access codes, but he demands a great price for his knowledge. Travelling to the tunnel’s terminus in either direction leads to an exit from Epsilon City. Other buildings are reachable from the subterranean tunnels, however every door is secured by a different code.

# BESTIARY

---

## SERVICE ROBOTS

---

### SECURITY BOTS –

Security robots are ovals of shiny silver metal, over 9’ tall, with a slight glow at the bottom for the anti-grav system. Their surfaces are smooth with lenses and tentacles hidden within the main body. These models have been overhauled to enforce nonlethal compliance. The robots instruments and weapons include: 4 telescoping tentacles with paralysis fields and a 10’ reach; 4 visual scopes that see up to 6 miles in light or dark, and cover the ultraviolet and infrared spectrums; dual aural pickups with a 90 meter radius; gas pellet ejector with 4 magazines of 30 pellets each (12 intensity paralysis poison); human action circuits; broadcast power receptors; hydrogen energy cells good for 72 hours of continuous operation and auxiliary energy cells good for another 24 hours; anti-grav propulsion; energy shields worth 50 hit points of force field generation; 2 slug ejectors with 2 magazines of 6 “bean bag” shots each (15 points of stun damage) and 1 magazine of 6 blue dye marker shots each; radio circuitry; 36 blue durable zip ties; and a wireless interface that allows the robot to take over other mechanicals. Each security robots has 100 hit points and reinforced zor plating (AC 2). The security robots automatically target and tie up any creature marked with a blue dye pack.

### HOVER DRONES –

Hover drones are extremely agile autonomous weapon platforms, roughly 1-meter square in size. The drones achieve their amazing maneuverability with quadwing technology, an array of 4 oscillating anti-gravity wings. The hover drones isolate Roma Complex by flying in a tight matrix around the structure. They only break formation to attack intruders. Each drones sports a range of instrumentation and lethal armaments: advanced multi-wavelength spectrum analyzers; 3 vision scopes with a variety of focal lenses and 2.9 petapixel resolution; life detection circuits with a 20m range; 1 protein disruptor auto-targeting turret (fires as a rifle) with the shield attachment option; sonic metal disruptor attachment; positronic submatrices; hydrogen energy cells good for 48 hours of continuous operation and auxiliary energy cells good for another 12 hours; energy shields worth 100 hit points of force field generation; and a green targeting laser. Each hover drone has 50 hit points and a laser-reflective surface (AC 2).

**TABLE 5-4: BIOG POWER TABLE**

| D14 | MUTATION OR DEFECT   |
|-----|--|
| 1   | ELECTRICAL GENERATION – Claw attacks cause 3 extra die electrical damage.  |
| 2   | ENERGY REFLECTION – Shiny skin that reflects 100% of an energy attack (Roll d5: 1 – laser; 2 – heat; 3 – electrical; 4 – radiation). |
| 3   | WINGS – Large wings that allow flight up to 100 yards per turn.  |
| 4   | CHAMELEON – Skin surface changes grant invisibility while standing still.  |
| 5   | POOR RESPIRATION – Biog must rest after every 5 melee turns.   |
| 6   | NO RESISTANCE TO POISON – Poison attacks automatically kill after 1 melee round.   |
| 7   | TELEKINESIS – The biog’s thought can lift objects up to 90 kilograms for 5 melee turns.  |
| 8   | MENTAL BLAST – A psychic attack that inflicts 3 die damage with 10 yards.  |
| 9   | LIFE LEECH – Once per melee round, the biog transfers 6 hit points from another organism to itself.                                  |
| 10  | MENTAL DEFENSELESSNESS – This mutation has a <i>mental resistance</i> of 3.  |
| 11  | POOR DUAL BRAIN – All attack damage is reduced by 1 die.   |
| 12  | WILL FORCE – This power doubles the effect of another mutant power once per day.   |
| 13  | Roll a random physical mutation or defect (MA pg 12).  |
| 14  | Roll a random mental mutation or defect (MA pg 14).  |

**HUNTER DRONE –**

Hunter drones are larger and deadlier cousins of hover drones, roughly 1-meter cubed in size. Despite their size, hunter drones retain some of the maneuverability of their smaller cousins through the use of dual quadwing system. A solitary hunter is sent in pursuit of Roma Complex escapees. Each hunter is equipped with a wide array of instrumentation and weapons: advanced multi-wavelength spectrum analyzers; 7 enhanced vision scopes with a variety of focal lenses and 4.7 petapixel resolution; life detection circuits with a 40m range; dual protein disruptor auto-targeting turrets (fires as a rifle) with the shield attachment option; sonic metal disruptor attachment; laser torch attachment; 4 telescoping manipulators; overclocked positronic meta-matrices; hydrogen energy cells good for 96 hours of continuous operation and auxiliary energy cells good for another 48 hours; energy shields worth 200 hit points of force field generation; and a red targeting laser. Hunter drones have 150 hit points and duralloy armor plating (AC 1).

**CREATURES OF THE ADVENTURE**

**BIOG (1d6) - AC:** Varies (d4+2), hp: 92, Movement in Spaces: 6, Radiation Resistance: 14, Constitution: 14, Mental Resistance: 10, STR: 16, DEX: 12

**Appearance:** The bio-engineered biogs are born four-armed humanoids with red eyes and dagger-like teeth, but can appropriate the body parts and even mutant powers of their victims (see “Rise of the Biogs” section for more details). As biogs kill, they diverge further and further from the natural physiques.

**Normal Reactions & Attacking:** Biogs prefer an overwhelming onslaught to subtle attacks. The strange mutations never use weapons or armor. They rely solely on their natural attacks, defenses, and abilities. All biogs have a vicious bite and claw attacks (Weapon Class 3, 2d6 damage).

**Mutations or Defects:**

Though every biog has regenerative powers in common, each is unique in appearance and other abilities. Roll thrice on the “Biog Power” table each time a group of biogs is encountered. Groups tend to mimic each other’s appearance and powers.

**REGENERATION –** Heals 4 die total of damage per day (as a free action).

**BLACK ONE (1d8)** - AC: 6, hp: 22, Movement in Spaces: 6, Radiation Resistance: 10, CON: 8, Mental Resistance: 3, STR: 8, DEX: 18

**Appearance:** This mutated spider has a black, hairy carapace and stands 4' tall. The fast-moving critters cooperate to weave a large arachnid web that traps potential prey.

**Normal Reactions & Attacking:** The black one hides in dark corners waiting for a victim to stumble into its web. Any creature that touches the web becomes stuck fast, and must roll a d20 under their Strength score to escape. Once trapped, the creatures scuttles forth and zaps its pretty with electrically charged fangs.

**Mutations or Defects:**

**SMALL BRAIN** – Immune to all mental attacks except illusion.

**SHOCK FANGS** – The fangs strike with a electric jolt (Weapon Class 3, 2d6 damage).

**BLOOD BIRD (2d6)** - AC: 5, hp: 23, Movement in Spaces: 10 flying/4 walking, Radiation Resistance: 18, CON: 8, Mental Resistance: 18, STR: 8, DEX: 16

**Appearance:** Blood birds are giant mutated birds, 2' in height. The birds have startling, bright red plumage, a patch of black feathers over their face, and a red beak, serrated to better slice flesh. The ravenous birds have traded their love of seeds and grains for still-warm blood.

**Normal Reactions & Attacking:** Blood birds hunt in flocks. Their primary attack is with their sharp beaks (Weapon class 3, 1d6) though most of their prey falls victim to the radiation they emit first.

**Mutations or Defects:**

**PEA BRAIN** – Immune to all mental attacks.

**IRRADIATED** – Its body gives off constant radiation at an intensity of 10

**DARK FUNGUS** - AC: 8, hp: 73, Movement in Spaces: -, Radiation Resistance: 15, CON: 16, Mental Resistance: 14, STR: 3, DEX: 3

**Appearance:** Dark fungus is a semi-intelligent, dark brown bracket fungus. The fungus colonies form clusters of shelves on vertical surfaces.

**Normal Reactions & Attacking:** Dark fungi primarily use their formidable mental powers to trick biological creatures into touching it at which time it leeches protein directly (and painfully) from their prey.

**Mutations or Defects:**

**MASS MIND** – Combine mental attacks with other fungus. Effects are multiplied by number of partici-

pating creatures. After the first melee turn, there 5% chance of mind burnout (instant death) increasing by 5% per round each melee turn after.

**ILLUSION GENERATION** – Creates images, sounds, and smells in the minds of others within 100'

**FORCE FIELD GENERATION** – Builds an invisible wall of energy in front of the mutation that takes 5 dice of damage to destroy

**MENTAL DEFENSELESSNESS** – This mutation defends with a *mental resistance* of 3.

**PROTEIN LEECH** – Biological organisms that touch the fungus take (10d6 damage) which adds 1 pound to the fungus' mass

**TELEPATHY** – The fungus have telepathy with a 50-yard range.

**DEATH GROWTH** - AC: 8, hp: 28, Movement in Spaces: -, Radiation Resistance: 13, CON: 8, Mental Resistance: 12, STR: 3, DEX: 8

**Appearance:** Death growth is a pale greyish parasitic fungus. The organism grows in dark and damp environments.

**Normal Reactions & Attacking:** Death growth attacks by shooting a spore cloud at a warm-blooded creature up to 5' away. Unless extreme heat is immediately applied (75% chance of killing the spores), the target falls under the control of the fungus. Over the course of 2 weeks, the fungus consumes its host. After the host dies, the dark fungus finishes consuming the corpse and waits for its next victim to wander by.

**Mutations or Defects:**

**IRON MIND** – Immune to all mental attacks.

**DEER (1d3)** - AC: 7, hp: 31, Movement in Spaces: 12, Radiation Resistance: 9, CON: 12, Mental Resistance: 9, STR: 12, DEX: 14

**Appearance:** These brown, furry, four-legged creatures run very swiftly. The sadistic predators stab their prey with the enormous racks of horns on their heads, delighting in screams of terror.

**Normal Reactions & Attacking:** Deer primarily attack by charging and stabbing with their antlers (Weapon Class 2, 2d6 damage). If the initial attack doesn't kill, the toxins on their antlers probably will (poison strength 15).

**Mutations or Defects:**

**POISON ANTLERS** – The deer's antlers are coated in highly toxic contact poison (poison strength 15).

**HISSER (1)** - AC: 5, hp: 73, Movement in Spaces: 8, Radiation Resistance: 12, CON: 14, Mental Resistance: 5, STR: 11, DEX: 15

**Appearance:** Hissers are ground dwelling, reptilian creatures. These beasts have long snouts, longer torsos, and even longer tails covered in a thick green hide and two tentacles on their heads. Hissers grow up to 4' long and walk on four legs with large webbed feet. The creatures lead solitary lives except during mating season.

**Normal Reactions & Attacking:** When hissers attack (which is often), they emit a loud hissing sound. Hissers make tentacle attacks twice per melee round. They can also bite with their sharp teeth (Weapon Class 3, 1d12+3), but rarely do so in combat unless all enemies have been paralyzed.

**Mutations or Defects:**

PARALYSIS TENTACLE – Touch paralyzes target for 4 hours (as a mental attack with mental strength 12)

RADIATION RESISTANCE – Thick hide is resistant to all forms of radiation

**HUMANOID #5 (2d3)** - AC: Varies (d6+1), hp: 49, Movement in Spaces: 6, Radiation Resistance: 12, CON: 12, Mental Resistance: 17, STR: 12, DEX: 10

**Appearance:** The fifth variant of mutated humanoid is slightly smaller than a true human, but with four arms and thicker skin. The humanoids are fully intelligent and can employ technological weapons and devices.

**Normal Reactions & Attacking:** These humanoids utilize whatever armor is available, anywhere from heavy furs to metal armor and shields. Each carries a melee and a missile weapon, for example, a mace (Weapon Class 3, 1d6 damage) and a longbow (Weapon Class 1, 1d8 damage). Each group has a 5% chance of also possessing (and knowing how to use) one technological item. Roll a d5: 1 – Vibro saw; 2 – Paralysis rod; 3 – 1d3 paralysis darts (charged); 4 – Geiger counter; 5 – Infrared goggles.

**Mutations or Defects:**

REFLECTIVE SKIN – Skin reflects all types of energy

**MEGABIOG (1)** - AC: 2, hp: 160, Movement in Spaces: 5, Radiation Resistance: 14, CON: 17, Mental Resistance: 12, STR: 18, DEX: 8

**Appearance:** Megabiogs are towering, bloated amalgamated monstrosities knit from the severed limbs, heads, and flesh of a hundred mutated creatures. The creatures reach such massive portions (sometimes nearly 20' in height) they are unable to bear their own weight and drag themselves along the ground leaving a slick of wretched secretions in their wake.

**Normal Reactions & Attacking:** Megabiogs attack like their smaller relatives, but they deliver 1 bite and 2 claw attacks every round (Weapon Class 3, 2d6 damage).

**Mutations or Defects:**

Megabiog have increased regeneration and other powers. Roll on the “Biog Power” table (see the “Biog” statblock) five times to determine its mutations.

INCREASED REGENERATION – Heals 8 die total of damage per day (as a free action).

**MONKEY PIG (1d4+3)** - AC: 7, hp: 50, Movement in Spaces: 4 climbing/6 walking, Radiation Resistance: 10, CON: 15, Mental Resistance: 10, STR: 16, DEX: 16

**Appearance:** Monkey pigs are ape-like creatures with shaggy auburn fur, fleshy grey faces with porcine snouts, and long powerful arms. These creatures have a natural inclination for climbing and swinging from trees. However, their hooved hands and feet make this difficult so they often fall.

**Normal Reactions & Attacking:** Monkey pigs can make powerful strikes with their hooves (Weapon Class 3, 3d6 damage). The creatures are masters of magnetism and use their power to disarm enemies. Monkey pigs are clumsy climbers. When they gain surprise, one of their group falls from a high spot onto a player character (1d10 damage).

**Mutations or Defects:**

MAGNETIC CONTROL – Repel or attract ferrous objects within 60'. Treat all objects as having *mental strength* 12.

HEIGHTENED HEARING – Sense and identify sounds 200' away, thus cannot be surprised.

FEAR IMPULSE (BEARS) – Immediately retreats from bears and ursine humanoid types.

**ORGAN RAT (3d6+3)** - AC: 8, hp: 18, Movement in Spaces: 6, Radiation Resistance: 18, CON: 7, Mental Resistance: 18, STR:12, DEX:14

**Appearance:** These rats escaped from Orcus' flesh vats into Roma from the ventilation shafts. They are used to farm organs and other body parts for the A.I.'s bioaugmented creations. The 2' long rats are hairless and covered in various growths such as tumor, internal organs, ears, fingers, and even limbs.

**Normal Reactions & Attacking:** Sharp teeth are the organ rat's only weapon (Weapon Class 3, 1d8 damage). Though they are physical weak, they are dangerous in large numbers due to their high resistances to non-physical attacks.

**Mutations or Defects:**

REFLECTIVE SKIN – Skin resists all energy attacks.

IRON MIND – Immune to all mental attacks.

COLD VULNERABILITY – Icy attacks do double damage to organ rats.

**ROMAN WOLFOID (2d4)** - AC: 4, hp: 73, Movement in Spaces: 8, Radiation Resistance: 12, CON: 15, Mental Resistance: 12, STR: 12, DEX: 17

**Appearance:** These lupine humanoids wear a garb typical of a Roman legionnaire. The red cloak manifests itself as a plus to the armor class. These wolfoids will never attack anything that looks like a dog, wolf, or bear. They will retreat from such battles. There is a 5% chance that a group contains 1 acolyte. Acolytes have identical statistics, but wear grey colorbands to access their deity's shrine.

**Normal Reactions & Attacking:** A typical legionnaire throws a Javelin (Weapon Class 4, inflicting 1d10 +4 in damage). It has a spear for a first strike in melee combat (Weapon Class 2, inflicting 1d12 +4). It can also wield a gladius sword (Weapon Class 2, strikes twice in a combat round, inflicting 1d10 +4 in combat). The trick of attacking twice in a combat round can be learned by characters after they use the weapon twice in combat.

**Mutations or Defects:**

REFLECTIVE FUR – Fur resists laser and other energy attacks

FIRE VULNERABILITY – Fire attacks do double damage to these wolfoids

TELEPATHY – These wolfoids have telepathy with a 150-yard range

**SINGING VINE** - AC: 8, hp: 33, Movement in Spaces: 3, Radiation Resistance: 17, CON: 6, Mental Resistance: 6, STR: 6, DEX: 6

**Appearance:** The singing vine is a 9' tall sun flower creature with a human face in a huge flower petal. Its root system allows it to move slowly on the ground. There are several stalk hands that allow it to grasp objects. It moves slowly.

**Normal Reaction & Attacking:** The plant creature can move along at a steady pace and when threatened it emits barely heard sonics that prevent any creature or intelligent being from harming it. The vine wants to use its sonics to tame creatures so that they stay around the singing vine and protect it.

**Mutations or Defects:**

CALMING SONICS – The vine can emit a sonic up to twenty yards away that can't be resisted. It makes the being totally calm and unable to harm the singing vine. That being will do everything in their power to protect the vine from dangers.

**WINGED BITER (1d3)** - AC: 4, hp: 19, Movement in Spaces: 12 flying/9 slithering, Radiation Resistance: 18, CON: 8 Mental Resistance: 17, STR: 10, DEX: 18

**Appearance:** The creature is six feet long with a three foot wing span. Its flesh changes color to match its surroundings.

**Normal Reaction & Attacking:** The creature is highly aggressive. Its flesh is resistant to paralysis and poison. The snake spits intensity 13 level poison every other melee round.

**Mutations or Defects:**

POWER LEECH – With skin-on-skin contact the mutant can absorb 1 random mutation from another mutant. This mutation stays for ten minutes.

APATHY FIELD – 4 times a day the mutant can make a mental attack to cause apathy. If the attack works the victim drops what each is holding and wanders away from the area.

# A60 PIRATE APARTMENTS

BY JAMES M. WARD

This adventure deals with a pirate themed apartment complex. Like a 21st-Century cruise ship, these complexes are designed to function as a city to themselves. Each apartment complex has levels of apartments, but also levels with recreation areas, restaurants, and fun places to play. These areas were filled with radiation and the sheer scale of the catastrophe meant the robots couldn't repair them. Now the surviving special robots of the city just try to maintain areas so all the strangeness of each area doesn't escape and change – or destroy – the city and the ship. The city has become a deadly zoo with the the remaining robot staff as it's zookeepers.

Bring your party to the north end of the apartments and then let them enter there or explore the outside ring of the first floor. They can come into the apartment area from any direction.

Each of the apartment complexes has a fun historical theme; in this case the Golden Age of Piracy (from circa 1650 to 1750 CE Earth dating). The ship replicators supply costumes and equipment suitable for that theme. Three hundred years ago, the pirate complex provided pirate costumes, plastic cutlass weapons, and fun toy pistols that gave light shows as they were fired.

When the radiation cloud moved through the ship, most of the humans turned to dust. The still functioning cleaning robots came around and vacuumed up the white dust and stored the thousands of bands away in a security hold (now destroyed). As time went on, wolfoids communicated with the insane A.I. of the city. They gained the ability to use the complex's replicators get sharp metal cutlasses and real blunderbuss pistols and rifles.

Decades later, truly monstrous creatures moved into areas in the Pirate Apartments as well as other portions of Epsilon City. The wolfoids, arriving on the scene afterwards, tried to remove these beings to better protect wolfoid children. Those efforts were doomed to failure. Now, the wolfoids make raids on the more dangerous areas of the apartments to get food and resources. The pirate wolfoids slowly chip away at the monstrosities living in what the wolfoids consider their own Pirate Complex.

This Pirate Complex is the most populous wolfoid area in all of the starship *Warden*. It has the most wolfoids of all ages as well as some of the best offensive equipment that the replicators can supply. Their greatest rivals include the even more ruthless and fearless Hun wolfoids; they have an uneasy detente with the Viking wolfoids, but outnumber them both.

## GENERAL NOTES ON THE PIRATE COMPLEX

### PIRATE CODE

---

Written on each of the stairs and inside all of the elevators is the Pirate Code or 'Articles', derived from one such humorously posted before the catastrophe. This Code is strictly followed by the wolfoids. Punishment is so severe for breaking a rule, that none of the wolfoids dares to deviate from the code. This is unusually lucky for any type of female coming into the area. A wolfoid will not attack a female. Instead the wolfoids kill or attempt to kill all the males of a group and try to capture the females without doing much damage to them. The females are sold as slaves, but can potentially escape as wolfoids have rules, incorporated into their Code, against physically harming females of any sentient species.

Notes on the CODE for the GM: Let the players read the code. Be sure and tell them that when they see the word "wolfoid" there is a printed "man" under the scrawl. Obviously the wolfoids have changed a bit of the code and added their own two sentences at the end of the code. What this means is that anyone dressed in a pirate outfit gets a chance to "sign on" to the code and become a member of the crew under the orders of the leaders of the wolfoids. If they don't sign on and yet flaunt pirate garb, it's a battle to the death. When there are only females left, they are encouraged by the wolfoids to run away. If they don't run, they are subdued and turned into slaves.

Pirate wolfoid society is deeply patriarchal. Female pirates and PC leaders will confuse them, which will give such characters significant leverage in dealing with them.

## CODE OF CONDUCT

Every wolfoid shall obey his Commander. The Captain shall take one full share and a half of all prizes. The Master Mate, Carpenter, Boatswain, and Gunner shall have one full share and a quarter. All the rest of the crew shall have one share of all prizes.

If any crew member shall steal any thing in the Company, he shall be shot.

Other pirates shall be offered a chance to sign the articles of this company. If they do they become full members of the company and all that implies.

The wolfoid that strikes another mate whilst these Articles are in force shall receive 40 strikes of the cat-o-nine-tails on his bare back.

That wolfoid that shall not keep his Arms clean, fit for an Engagement or neglect his Business shall be cut from his Share. He receives punishment as the Captain sees fit.

If any wolfoid shall meet a prudent WOMAN, that Wolfoid that offers to meddle with her without her consent shall suffer immediate Death.

If a wolfoid attacks and physically harms a Female he will suffer punishment from that Female unless he can make her his slave.

If a wolfoid attacks a metal man, the wolfoid will suffer punishment given from his Captain.

## PIRATE FLAGS

Pirate flags are used to mark territory in the apartment complex. If one takes the proper colored flag into the territory of the proper pack he won't be attacked and he can parley with the pack and even join in the pack's accords if he wishes. Throughout the city if characters are bright enough they can use a colored skull & crossbones to parley with any wolfoids group without hav-

ing to fight first. In most cases Wolfoid packs tend to shoot first and talk later.

There are three packs of wolfoids living in this area. The Orange wolfoid pack has 80 adult members. All of their tricorne hats and their vests are colored orange. The Red wolfoid pack has 250 members and their hats and vests are colored red. The Blue wolfoid pack has 200 adult members and their hats and vests are bright blue.

## NORMAL APARTMENT COMPLEXES

Each of these apartments resembles a fancy hotel room. There are three different sizes. All of them have much the same equipment -- large vision screen, large washroom with a shower and a hot tub, walk in storage closet, sitting room, small kitchenette, and a good sized bedroom. All apartments have open doors. Their doors have been in years passed propped open so the door can't lock the area closed. Each bed has a set of pirate clothes with a cutlass and a gunpowder pistol. There is a powder horn and round metal bullets in a large shoulder pouch.

There are three different sized apartments. The single has a king sized bed and is the smallest in total square feet. The double has two queen-sized beds and the sitting room is large enough for ten people to sit and watch the vision screen. The family apartment has a king sized bed for the parents, a second bedroom with a queen sized bed, and a third bedroom with four bunk beds

## RUINED APARTMENTS

These are rooms where the plants have come in and claimed all of the rooms. There are several feet of earth on all of the floors. All of the furniture is rotted and in ruin. Robots never go in these rooms for any reason. A number of examples are found in the Epsilon City Bestiary.

There is a 20% chance of a band being found in ruined apartments. Roll on the following table to determine the bands found, Roll % dice: 1-40: brown, 41-65, green, 66-79, gray, 80-91, white, 92-95 red, and 96-00 other (specialized or GM's discretion).



## UNUSED APARTMENTS

These are serviced by robots. On each bed is a large sized pirate costume with a real metal cutlass, real blunderbuss pistol, and pistol shot and gunpowder. The replicator in the kitchenette works perfectly. The vision screen provides scenes of different parts of the ship with random jumps from scene to scene without control of the watchers.

## WOLFOID APARTMENTS

Each open door is covered with some type of hides. The more vicious and dangerous the monster the hide was taken from, the more honor the family inside that apartment. Three to nine wolfoids living in each apartment complex. Wolfoids cover their areas in thick furs of all types.

---

## STAIRS AND ELEVATORS

The stairs all appear to be a black and white marble that is really a very dense plastic that looks and feels like stone. Such stairs are all yards wide and easy to climb. There are electric seats on both sides of the stairs that can be summoned with the press of a button. The chairs travel from the lowest level to the highest level with the touch of a button on the arm of the chair. On each landing, the Pirate Code is written on the walls. These stairs are cleaned by the remaining robots three times a day.

Elevators are in many sections of the apartments. The elevators on the north and south ends go up and down to all levels. One must be using a band to summon an elevator. Elevators play enthusiastic pirate sea chants. One is encouraged to yell, "Yo, Ho, Ho!" in order for the elevator doors to open. The Pirate Code is written on the walls inside of the elevator.

---

## ENTRANCES TO THE APARTMENT

Road – There is a wide road all the way around the apartment complex. It is possible to come at the area from any direction. Wolfoids regularly roam the area in packs of 3-6. 1-76% of the time the packs are made up of very young Wolfoids on their first roaming quest.

Balconies (Maps 1 & 2) – There are hundreds of balconies on each floor of the apartment levels; one for each apartment. Ropes or other devices can easily get characters to those staging areas. All balconies are covered in thick plants. 75% of them are normal and

extremely large plants as the gardening bots maintain and fertilize all of these plants. Every balcony has a thriving complex of plants blocking open the door to an inside apartment.

1-25% of the time there is one of two unusual things in the balcony plant mix (roll d100):

01-55% A Winged Biter has a nest with three freshly hatched winged biters in the plant mix.

56-100% A Rope Circle thrives in the plant mix. If this is the case there are from 3-12 destroyed garden robots in this area.

First Floor (Map 1) – All of the first floor is open to entrance on any side. However there are natural and unnatural obstacles to be detailed later. From these open areas characters can reach stairs up and elevators up. The elevators can't be worked without a band.

Roof (Map 5) – The roof is open on all sides. There is no problem flying to its surface and there are several large spots clear for landing.

Apartment Transports (Maps 1 & 2) – Each of the transports has an opening on the outside that anyone can use and an opening that extends into the building. When parked these units have both sides open.

---

## ON LOOKING AT THE APARTMENT COMPLEX

**You see five levels. At the two lowest levels there are transports at every opening. The lower areas are all open and you can see inside. There are lights in the ceilings. Strange flags hang from the ceilings in several places. The third and fourth floors have many open balconies. Each of these is stuffed full with plants and bushes. It's impossible to tell from the ground what is on the roof of the complex.**

SPECIAL NOTE: When it comes to making a pure human walk the plank, that plank is on the roof of the building and the human falls 50 yards. At the street level there are five Wolfoids looking to make a meal out of the fallen human.

## MAIN FLOOR

### A – CITY TRANSPORT VEHICLES

---

Each of these vehicles is a fully functional 8-person air transport. If you know the name of the location you wish to go to, and you are wearing any color band, you can direct the transport to fly to that location. The transport won't open an elevator door, but it will stop and wait for a rider to open the door. The transport tries to take passengers to their location, avoiding large obstacles and other vehicles, but ignores obvious dangers outside of these restrictions. It would drive over a radiation area or through a pack of well armed wolfoids. It has a fairly intelligent artificial intelligence. Some crazed A.I. level controllers, however, can refuse to let the transports onto their levels. While they have broadcast energy for their power system, they also have huge batteries powering the units for 72 hours of constant operation. The hulls of these vehicles are thin and easily destroyed. Each unit takes up to 40 points of damage before crashing. The controls have an item complexity of 8 because the unit can talk with the characters; PCs can take manual control of the vehicle if they can beat that complexity.

**You see a long row of what appears to be 8-person vehicles after looking at the seats. Each of the vehicles has open doors on both sides of the vehicles. One side opens to the street and the other side opens into the apartment structure. Each vehicle is spotless and appears ready to go.**

### B – OVERGROWN FOOD COURT

---

Looking at the area from outside the complex, one notes a mix of overgrown fungi patches and the tables and chairs of a restaurant. Every day robots come and change out the plates, silverware, and cups on the tables and clean them and place clean equipment on the tables. The robots do this by pushing through the 3-5 feet tall patches of fungus. The entire area is a rainbow of relatively harmless fungus that has grown wild in the three hundred years of radiation exposure and mutant exploring. If beings push through this area they get large clumps of colored fungi sticking to their suits and flesh.

On the northwest and southeast ends of the fungus area are single winged biter nests with three large eggs

in each nest. A female winged biter will defend these nests to the death. When characters get within ten yards of these nests, the female flies into the air above the nest and hisses her displeasure. She attacks if the characters come closer.

The area is approximately 100 yards wide by 150 yards long. The ceiling is constantly cleaned and lights replaced by robots as needed. At the north end of this area is a set of stairs going up to the next level.

Also on those stairs is a pair of orange skull & cross-bones flags. The flags mark the territory of the Orange wolfoid pack. The two winged biters will not attack orange pirates unless the pirates attack the biter nests first.

**You are looking at a large open area filled with fungi. There are many patches of fungi in a rainbow of colors all over the area. You see what appear to be tables and chairs in the fungi piles. On top of the tables are cleared areas, and plates, cups, and tableware are clean and set out in these areas. The area is well lit by light fixtures in the ceilings. To the north there is a large alcove that shows a wide set of stairs up as well as some metal doors clear of fungi.**



SBP

# PIRATE COMPLEX

## Map 1 Main Floor

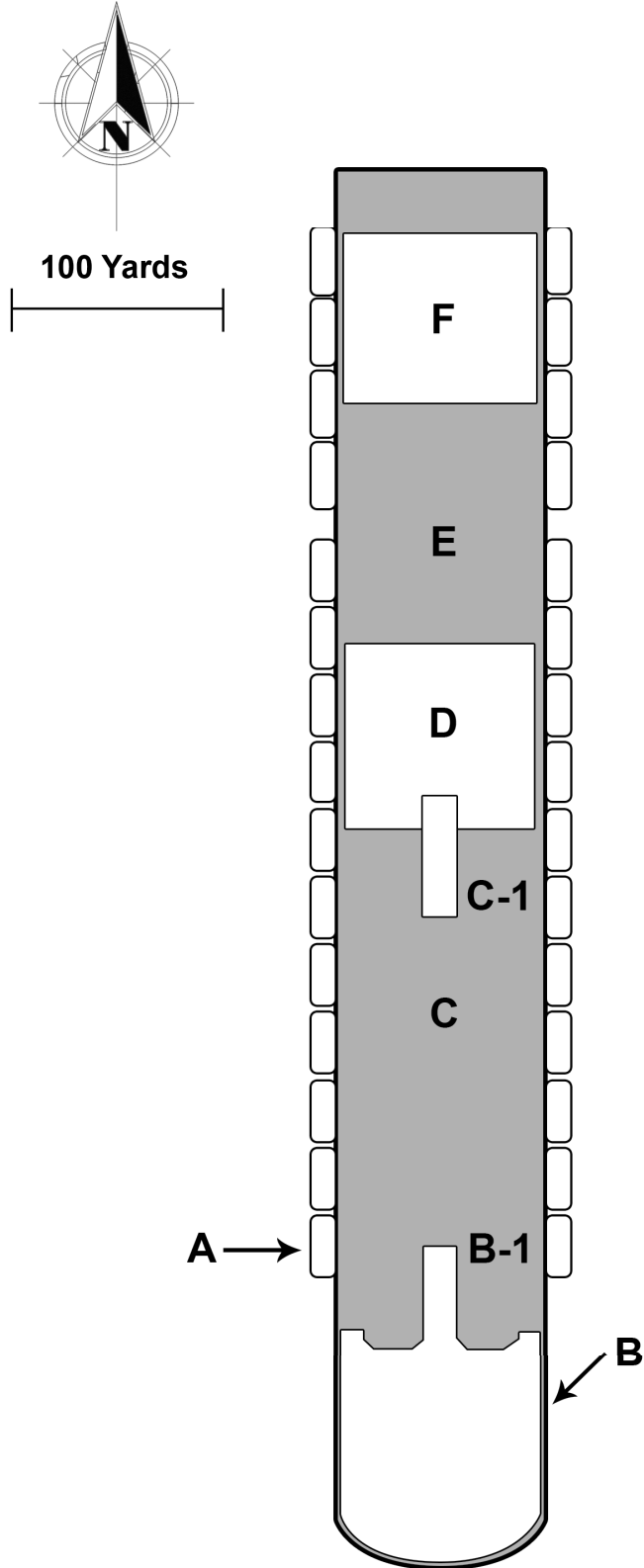

**Winged Biter** - AC: 4, hp: 19, Movement in Spaces: 12 flying/9 slithering, Radiation Resistance: 18, CON: 8, Mental Resistance: 17, STR: 10, DEX: 18

**Appearance:** The creature is six feet long with a three foot wing span. Its flesh changes color to match its surroundings.

**Normal Reaction & Attacking:** The creature is highly aggressive. Its flesh is resistant to paralysis and poison. The snake spits intensity 13 level poison every other melee round.

**Mutations or Defects:**

**POWER LEACH** – With skin-on-skin contact the mutant can absorb 1 random mutation from another mutant. This mutational power stays for ten minutes.

**APATHY FIELD** – 4 times a day the mutant can make a mental attack to cause apathy. If the attack works the victim drops what he is holding and wanders away from the area.

## B1 – STAIRS UP TO EMPRESS DECK (MAP 2)

A security robot guards this area. There are two Orange skull & crossbones flags hanging here. The stairs up are sparkling clean and maintained by cleaning robots. Characters can go up the stairs with no problem as long as they don't make a mess. The security robot will defend itself and call for two more security robots that arrive in 10 minutes if it is attacked.

There are elevators here as well. They cannot be opened unless one of the characters has some sort of band. These elevators go to all of the other levels. They are sparkling clean as well and maintained very day by cleaning robots. If the characters damage the elevators, they are attacked by a security robot.

**You see a clear alcove to the north of the fungi area. The ceiling is filled with lights. The floor and wide stairs up are made of black and white marble. There are two large metal doors to the left and right on the walls. There is a brown color band rectangle four feet up on the wall by each of the metal doors. Against the wall on the left and right of the wide stairs there is a large chair that looks to be attached to the wall. Hanging to the ceiling by the stairs are two large orange skull & crossbone flags.**

## **SECURITY BOTS**

Security bots are all 9 feet tall ovals of shiny silver metal. Their surface is smooth with lenses and their manipulation tentacles are hidden inside the body. There is a slight glow at the bottom produced by the anti-gravity system. Four 4-meter tentacles with paralysis fields – 2 visual lenses good up to 6 miles in light or dark, sound receptors good for 90 meters, gas pellet ejector with 4 magazines of 30 pellets each (12 intensity paralysis poison), Human action circuits, broadcast power receptors, emergency power cells good for 72 hours, Anti-grav propulsion, body armor for AC 2, energy shields worth 50 hit points of force field generation, 2 slug ejectors with 6 magazines of 12 shots each (15 points of stun damage), radio circuits, 3 padded 12 meter tentacles, 4 lenses looking into the ultra-violet and infrared spectrums, 100 hit points, and mechanical circuitry allowing the robot to take over other mechanicals.

## C – KITCHENS FOR THE APARTMENT COMPLEX

The area is 300 yards long and 100 yards wide. It is filled with sparkling clean cooking surfaces from stoves and ovens to holding trays, dishwashers, and replicators. Originally it was used to cook special meals for the various restaurants of the apartment complex. Robots started using it for a holding area so now there are four of each type of robot stored and working there. Even the security bots do cleaning of the area on a daily basis. Those same robots handle the removal of non-wolfoid characters that try to explore this area. From the outside looking in, the area looks like a huge kitchen. There are Orange wolfoid pack skull & crossbone flags flying in the area. Those of the Orange pack can come in and cook special meals while all others are gently told to leave.

**You see a huge cooking area. The kitchen tools, pans, pots, and appliances are made of gleaming steel. The floors are black and white marble. There are several different kinds of robots cleaning in the area. In the northwest section and the southeast section hang orange skull & crossbone flags. In the middle of the area are three wolfoids dressed in orange pirate uniforms. They are busy chopping and cooking up some large creature. As bits of it are finished one of the Wolfoids takes large plates on trays to an elevator at the south of the kitchen.**

Robots are listed later in this document.

# PIRATE COMPLEX

## Map 2 Empress Floor

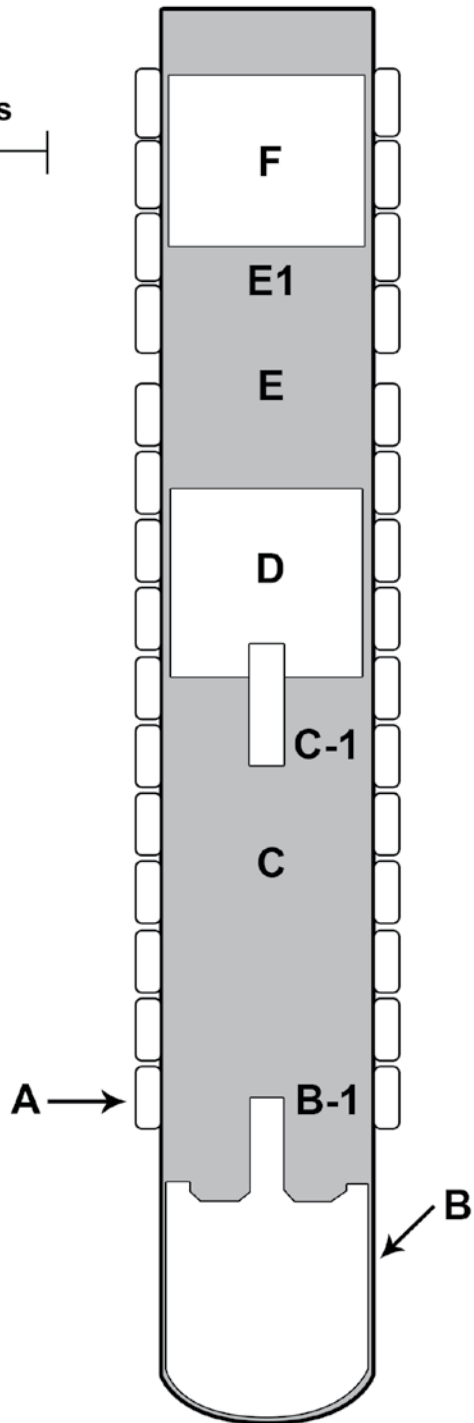

**Pirate Wolfoids (4)**AC: 3, hp: 60 x4, Movement in Spaces: 15, Radiation Resistance: 15, CON: 16, Mental Resistance: 12, STR: 12, DEX: 18

**Appearance:** These bipeds stand 9 feet tall and have manipulative paws. Their fur is bright red, suggesting some sort of mutation. Their eyes also glow bright red from its radiated eye mutation. One of the wolfoids has a green band, the sort that is needed to open an elevator in this complex.

**Normal Reaction & Attacking:** It takes very little to start a fight with these wolfoids. Pirate wolfoids all bear a cutlass for a melee weapon and a single shot blunderbuss pistol for a ranged weapon, tucked into their belts. These pirates roar at any characters coming into the kitchen. They are clearly motioning strange characters to leave the area.

CUTLASS – Weapon Class 3, Damage 1d8/1d6/1d12

BLUNDERBUSS PISTOL – Weapon Class 5, Damage 3d6, Range (short) 10 yards, (medium) 11-30 yards, (long) 31-40 yards

**Mutations or Defects:**

MANIPULATIVE PAWS – allows the mutant to handle any human built device.

REFLECTIVE FUR – Reflects all types of energy.

CONTACT POISON RESISTANT – Its fur resists all the affects of contact poison.

REGENERATION – This mutant regenerates 5 lost hit points per melee round.

RADIATED EYES – 14 intensity useable once per day

## **C1 – STAIRS UP TO EMPRESS DECK (MAP 2)**

The stairs are spotless and there is a pair of Orange Wolfoid Pirate flags flying on the stairs. The elevators are guarded by a single security bot that will summon other bots if the elevators are attacked by nonbanded characters.

### **SECURITY BOTS**

Security bots are all 9-foot tall ovals of shiny silvery metal. The surface is smooth with lenses and tentacles hidden inside the body. There is a slight glow at the bottom for the anti-gravity system. They possess four 4 meter tentacles with paralysis fields, 2 visual lenses good up to 6 miles in light or dark, sound receptors good for 90 meters, gas pellet ejector with 4 magazines of 30 pellets each (12 intensity paralysis poison), Human action circuits, broadcast power receptors, emergency power cells good for 72 hours, Anti-grav propul-

sion, body armor for AC 2, energy shields worth 50 hit points of force field generation, 2 slug ejectors with 6 magazines of 12 shots each (15 points of stun damage), radio circuits, 3 padded 12 meter tentacles, 4 lenses looking into the ultra-violet and infrared spectrums, 100 hit points, and mechanical circuitry allowing the robot to take over other mechanicals.

**You see a wide set of stairs up. On the right and left of the stairs are large chairs. There are grooves in the walls and it looks like these chairs could move up the wall and take beings that couldn't walk up the stairs. Floating in the middle of the area is an oval security bot. It is there to stop beings from attacking and ruining the area. It ignores characters that do no damage and just try using the elevators or walking up the stairs.**

D – This is the Crimson Restaurant of the Red wolfoid pack. There is a large red skull & crossbones flag flying in each corner of the area. The Red wolfoids present this area as an example of the power of this pack. Anyone can come and eat at this restaurant. Four unarmed wolfoids come to serve character groups. These wolfoids use a small wrist A.I. that translates dialogue from the wolfoids to the characters.

The area is roughly 100 yards by 100 yards. The chairs and tables are sparkling clean. There is a hologram movie running in the center of the area. It's a movie from the 1980s with lots of scenes about nature and forests.

If a fight breaks out for any reason a band of four well-armed Red wolfoids comes from the north and engages the group in battle. Many more Red wolfoids can come from the north is the first group is quickly killed.

**The smells of a cooking area greet you as you look into this food service area. Some type of play/movie is playing and showing a forest area with someone singing. There are four unarmed Red pirate wolfoids walking around the area doing chores like moving chairs and tables around. In the northwest corner and the southeast corner are red skull & crossbones flags flying. One can see fifty or so tables and chairs with plates, cups, and table wear set on each of the tables.**

## E – DEATH SPHERE AREA

---

Plants and shrubs fill this area. The lights on the ceiling are constantly being replaced by robots. Those same robots are constantly being attacked by the younger and more maneuverable Death Spheres. The area is 100 yards wide by 150 yards long. The ceiling is 20 feet above the floor. It looks like the floor is made of black and white marble, but actually it's a spun plastic (as elsewhere in the complex).

This was a staging area for coming into the apartment complex and leaving for excursions all over the city. To the north of this area are sets of guest services machines where you can get hundreds of different styles of drinks. The machines still serve liquids. There are several destroyed engineering robots in this area. There are also washrooms filled with nasty smelling yellow fungus. As characters walk on these mats of fungus they expel huge clouds of yellow spores floating into the air. This spore is a intensity 10 poison. If it isn't resisted it goes into the lungs of the characters and grows quickly. The fungus does 3 points of damage a day until it fills the lungs and kills the character.

At the center of this area is a 15-foot tall death sphere. There are four, five-foot tall young death spheres rolling about the area. These young versions have 20 hit points and can only use one of the powers of the adult. The adult sphere stays in the center area and attacks any characters that come within range.

**You see a large room overgrown by brush and weeds. There are tall shrubs and thick thorny vines filling the area. There are at least ten broken engineering robots in pieces in the brush all around the area. In the middle and to the north you can see a cleared section with metal doors and stairs.**

**Death Sphere** - AC: 6, hp: 56, Movement in Spaces: 8, Radiation Resistance: 15, CON: 8, Mental Resistance: 8, STR: 3, DEX: 17

**Appearance:** In adult form the sphere is 7 feet high and has a diameter of 6 feet. It's a sphere with lots of spore holes along its sides. Each section of spore holes blasts out a different type of spore depending on the hour of the day. The creature is able to slowly roll across most surfaces. Most spheres have the same coloring as their surroundings and are hard to see until a being is within 10 yards of the creature.

**Normal Reaction & Attacking:** The creature spews forth with one of its attacks and can sense foes up to 100 yards away.

### Mutations or Defects:

**HEAT BREATH** – With a range of 5 yards this mutant fires a blast of flame for 5d6 damage once a day.

**ACIDIC VOMIT** – With a range of 1 yard this mutant blasts acidic vomit for 3d6 in damage once a day.

**HIVE HOST** – The hornet swarm attacks as a Weapon Class 1 with an armor class of 1 and a poison class of 3. 5d6 are rolled for the hornets and every 6 is a strike each melee round. They attack for three melee rounds and then go back into the mutant.

**INK EXPULSION** – The mutant generates a huge cloud of dark ink that stays suspended around the mutant with a range of 60 feet until a breeze blows the ink away. The mutant has the use of all of his senses within the ink cloud. He can generate this cloud once a day.

**SLIME** – The mutant generates extremely slippery slime three times a day. This slime is impossible to stand or walk through.

## E1 – ELEVATORS AND STAIRS UP TO EMPRESS DECK (MAP 2)

---

The stairs are spotless and there is a pair of Red wolfoid pirate flags flying on the stairs. The elevators have a destroyed security bot at the center of the corridor. The Red Wolfoids send down young members of the pack. These members attack the constantly moving life of the lower area. It's a test of courage for the Wolfoids. So far they have been able to fight off the mutants.

**You see a wide set of stairs up. On the right and left of the stairs are large chairs. There are grooves in the walls and it looks like these chairs could move up the wall and lift beings that couldn't walk up the stairs. Hanging in the area are two red skull & crossbones flags.**

## F – BATTLING AUDITORIUM

---

This area is an auditorium with deeper and deeper seats as the rows of seats gets closer to the stage. The entire area is sparkling clean. The wide stage is covered in a foot of sand. At 12 noon and 6 pm the auditorium fills with red, orange, and blue Wolfoids. All ages and both sexes are represented. There are three skull & crossbone flags for each of the three colors of the packs: red, blue, and orange. These fly in several areas all around the stadium.

Four security robots roam the area and keep out all other creatures. When there isn't a show, other beings

are allowed to roam this area. Such beings are not allowed to make a mess or set up lairs or nests.

For two hours there are several different types of duels on the stage. Most of the time the duels are cutlass battles between a pair of opponents. A score board lists the kills by color and wolfoid name. Some of the battles are pairs of wolfoids: male and female. At the end of every session there is a larger battle between two colors using ten wolfoids each. These battles are fought until an opponent is incapacitated and not necessarily killed. Lizard men are officials in each of these fights. The officials have huge pole arms and wolfoids are supposed to stop fighting when the pole arm comes between the battlers. Sometimes the wolfoids become unruly or break the rules and when that happens the much stronger lizard judge chops off the head of the offender.

Battles can be watched outside the auditorium from out on the street and those characters are not bothered by wolfoids.

Most of the three packs come down to watch the events. These wolfoids ignore characters if they stay out of the area as if they were not worth bothering about. Those characters that come into the auditorium during a fight are first attacked by the four security bots and then attacked by hundreds of wolfoids.

**You see a huge empty auditorium with hundreds of seats in front of a large stage. The stage has a foot of sand everywhere. You note three different colors of skull & crossbones flags hanging from the sealing: red, blue, and orange. There are four security bots patrolling the area and moving in a complex pattern that traverses the entire area. The auditorium appears to be 100 yards wide by 150 yards long. The stage fills the north end.**

## EMPRESS FLOOR

### A – EMPRESS FLOOR CITY TRANSPORT VEHICLES

---

These transports are much like the ones on the street and Main Floor. The doors to the outside street are not open for safety's sake. The doors to the apartments are all open and each vehicle is ready for use.

**You see a long row of what appears to be 8 person vehicles after counting at the seats. Each of the vehicles has doors open towards the apartments side. One side opens to the street and the other side opens into the apartment structure. Each vehicle is spotless and appears ready to go.**

### B – SWAMP AREA

---

On the second floor, this 100-yard wide by 150-yard long section of the apartments was another section of the downstairs restaurant. It was hit with radiation and after many battles here all the furnishings were ruined. Multiple attempts by robots to fix the damage were stymied by the encroaching bubble frogs. Thus, robots stopped coming into this area over a hundred years ago. Now everything is in ruins and there is a thick, several feet deep, layer of muck, fungi, and dark plants of all types. Several huge bubble frogs live in this area. They are very aggressive and immediately attack characters looking to swallow a quick meal. The area is very dark as all of the lights have broken long ago. Sticking out of the muck are ten to 20 robot parts. Around these parts are sodden boxes of useful tools, scattered by the robotic repair teams.

It's difficult to walk in the muck and characters are slowed way down. The muck clings to the bodies of those trying to get through this area.

**In darkness you can barely see a swampy area. Huge mushrooms, swamp brush, and the smell of mold and damp fill this area. In the distance there are splashes from what could be large creatures coming your way.**



**Bubble Frog** - AC: 8, hp: 59, Movement in Spaces: 12 leaping/9 swamp, Radiation Resistance: 13, CON: 13, Mental Resistance: 13, STR: 13, DEX: 13

**Appearance:** The frog is fifteen feet long and has a fanged mouth that can easily swallow a humanoid whole. There are 20-40 fist size bubbles around its body. Its flesh blends in with whatever terrain it is standing along side at the time.

**Normal Reaction & Attacking:** The creature is highly aggressive. Its flesh is resistant to paralysis and poison. It bites for 3d6. It is also smart enough to try pouncing on prey to hold them down and crush them with their weight. There is a 1-50% chance of bursting a bubble when trying to melee this creature. The bubbles have three different types of chemicals in them and the mutant is immune to all of the affects. Roll a d6 to determine what flies out of the bubble.

- |     |   |
|-----|---|
| 1-2 | Intensity 15 poison contact spores  |
| 3-4 | Acid mist doing 4d6 in an area around the frog and continuing to do this damage until a breeze blows the acid away. |
| 5-6 | An inky blackness in a 40-foot area around the mutant that the mutant can see right through.                        |

#### **Mutations or Defects:**

**BUBBLE FUNGI POD** – The creature shoots out one of three different types of randomly chosen fungi when a random bubble is burst.

### **B1 – STAIRS UP AND DOWN TO MAP 1 AND MAP 3**

This area is dark and not maintained by robots or wolfoids. There is a thick layer of thorn bushes in this entire area. At the center of this thorny brush is a lair of four bubble foxes. There are three bubble fox pups in the lair.

In this brush area are six destroyed robots of various types. There are also the defleshed skulls of 9 wolfoids. In a pile by one elevator is a mass of miscellaneous weapons and ammunition. The bubble foxes don't know how to use those weapons, but they know they don't want others using them. There is a pile of intensity 3 poison thorns covering the mass of laser pistols, slug projectors, cap and ball pistols, and several fragmentation grenades. It would be necessary to kill the four bubble foxes to get at this material safely.

**WASHROOMS** -- There are several men's and women's washrooms in this area. Over a hundred years ago a mass of high intensity radiated water went through the pipes in this area. Now these washrooms glow bright green. There are no plants or other things in this area because of the intensity 15 radiation. As any of the doors are opened the radiation glows brightly and there are a number of different types of robots whose power systems have been destroyed by the radiation laying about the washroom.

**There is a dense blackness in this area. The thorn vines have been without light for many years and are dead, dried husks. The metal elevator doors are all scratched up and covered in dried muck. Dead vines are thick in this area. You can hear a rustling of some sort of creatures moving around in the vines.**



# PIRATE COMPLEX

## Map 3 Vista Floor

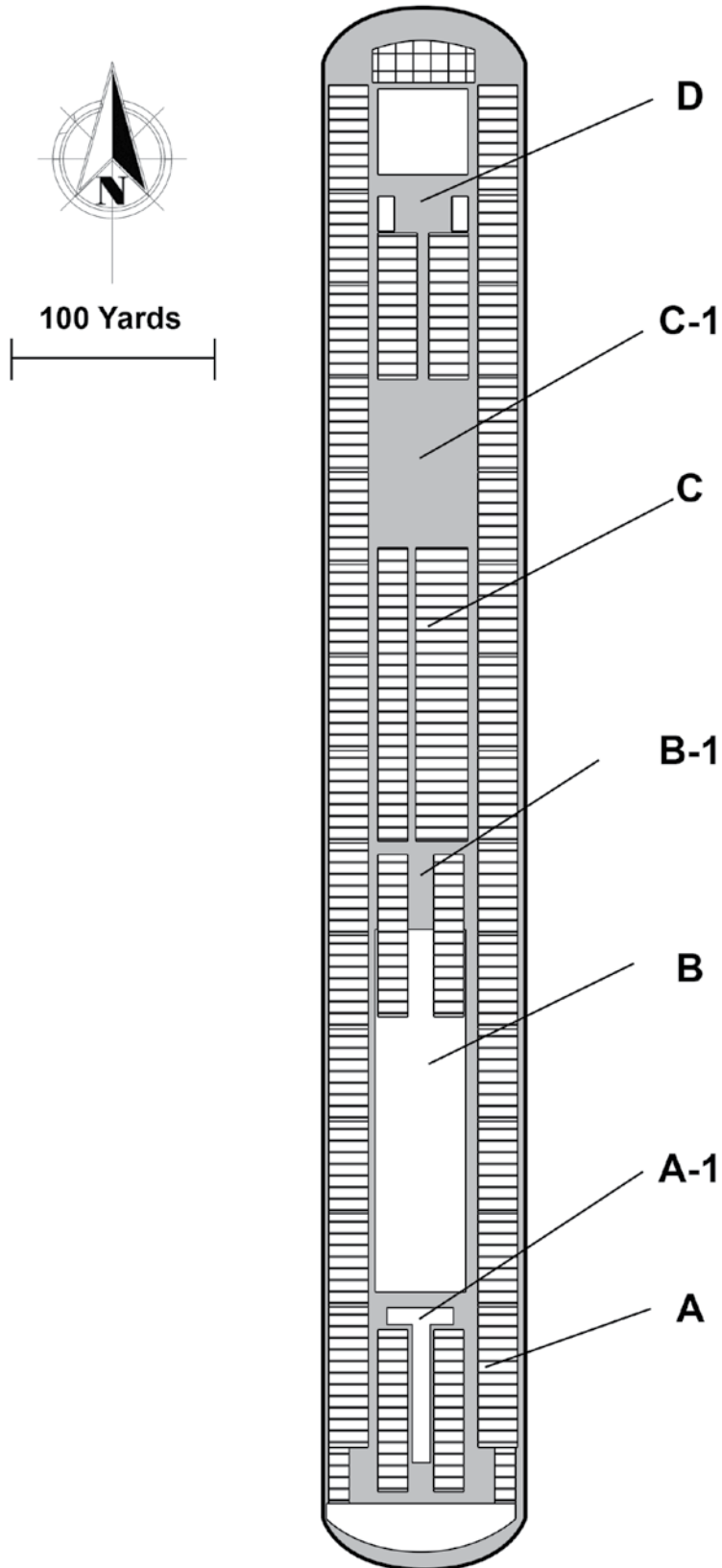

**Bubble Fox (4)** - AC: 3, hp: 89, Movement in Spaces: 16, Radiation Resistance: 14, CON: 16, Mental Resistance: 10, STR: 10, DEX: 18

**Appearance:** This fox is four feet tall at the shoulders and seven feet long. There are 20-40 fist-sized bubbles protruding from its body. Its fur and skin blends in with whatever terrain or surfaces it is standing along side at the time.

**Normal Reaction and Attacking:** The creature is highly aggressive. It bites for 2d6 damage. There is a 1-50% chance of bursting a bubble when trying to melee this creature. The bubbles have three different types of chemicals in them and the mutant is immune to all of the affects. Roll a d6 to determine what flies out of the bubble.

#### D6 WHAT FLIES OUT

|     |  |
|-----|--|
| 1-2 | Intensity 9 radiation  |
| 3-4 | Vomit inducing spores with a 1-40% chance of making a victim helpless for 2 combat rounds. |
| 5-6 | An inky blackness in a 40-foot area around the mutant that the fox can see right through.  |

#### Mutations or Defects:

**BUBBLE FUNGI POD** – The creature shoots out one of three different types of randomly chosen fungi when a random bubble is burst.

### C – BLACK ANT SAND DUNES

---

For several hundred years the ants of this area have been bringing back sand and earth from open ground and planters around the level. The ants go out in five-ant scouting missions to look for more sand and earth. The corridors and rooms of this area are filled with sand, mud and dirt, with excavated tunnels connecting everything. At the center of this mass is a queen ant chamber with a huge queen ant and a hundred eggs. The ants are confused about hand grenades. Over the years they have collected 33 thinking they are eggs of some type and need to be hatched. These weapons all lay in a pyramid next to the entrance to the egg chamber.

The area of control is 100 yards wide and several hundred yards long. Tunnels run everywhere. There are lots of robot parts as robots have come in trying to clean up and fix things and the powerful ants have mass attacked and destroyed the units.

**You see a tunnel into a large mass of sand and dirt. It's very dark. There are several robot parts sticking out of the sandy walls.**

The ants attack in groups of three. When the characters come to the area of the queen chamber ten ants come out to attack.

**Black Ant Mutant** - AC:5, hp: 77, Movement in Spaces: 12, Radiation Resistance: 17, CON: 17, Mental Resistance: 4, STR: 18, DEX: 10

**Appearance:** These giant black ants are four feet long, and three feet tall at the shoulder. They move quickly, wherever they go. They make an odd clackety-clackety sound as they move and this can be heard for up to 100 yards away. Their pincers are huge and constantly in motion. They are strong enough to cut down large trees with one pincer motion.

**Normal Reaction and Attacking:** Their pincer cuts for 6d6 of damage with each successful strike.

#### Mutations or Defects:

**HEIGHTENED SPEED** – The mutant can make two attacks per combat round.

**MOLECULAR STAGNATION** – Twice a day, after a successful strike the mutant drains all the power from the victim and his or her devices when struck. The victims have their batteries drained to zero energy. If they are using broadcast energy devices those units are broken. With each drain the mutant gains 6 hit points.

**PROTECTIVE COATING** – This protective coating is used to firm up the sand and give the walls and ceiling of the tunnels an armor class of 4. The walls created have a sort of varnish on them and seem very hard. It only takes 3 hit points of break through this coating.

### C1 – STAIRS AND ELEVATOR UP AND DOWN

---

There is an elevator set and a set of stairs to the south. At the stairs there are two red skull & crossbones flags hanging. However, the wolfoids do not go past the stairs or use the elevators for this floor for fear of getting attacked by ants. The ants rule this area. Occasionally they go up the stairs and into the Wolfoid area where the ants are quickly killed from a distance. There is a lot of sand and earth in this area, but it doesn't stop the elevators from working. There are always at least two warrior ants in this section ready to do battle.

**You can see the elevator doors and the stairs in the south section of this area. There is at least two foot deep of sand and earth on the floor in this section. You hear a clackity sound and then two ants appear out of the sand. They are coming to attack you!**

**Black Ant Mutant (2)** - (see above)

There is a backpack stuck in the sand wall by the elevator. Inside the pack is a vibro axe that does 30 points of damage per strike. There is also a type C force field tent and two force batons with no installed energy cells.

---

## D – DEADLY ROPE CIRCLE

---

300 years ago this was a forest-themed restaurant. Over the years the trees grew up to the ceiling and now the entire ceiling area is filled with branches and leaves. The table and chairs are buried in leaves and other mulch. There are tree roots trunks all over the place. The area is approximately 100 yards wide and 175 yards long. At the center of the area is an adult rope circle plant. There are large root tentacles all over the area that connect up to the rope circle plant.

The monster wants to grab victims and pull them into pod sections at the rim of the plant.

Over the years lots of creatures have been eaten by the plant and the creatures' equipment that didn't dissolve in the acids of the plant are lying all around the sides of the plant. These things include many types of swords and combat knives; camping equipment including pots and pans and flashlights, and longer devices like long metal staves and bits and pieces of metal armor.

**Rope Circles** - AC: 4, hp: 100, Movement in Spaces: 10, Radiation Resistance: 16, CON: 18, Mental Resistance: 17, STR: 11, DEX: 8

**Appearance:** This plant creature can change colors to match its surroundings. An adult version is four feet tall and has a diameter of 12 feet. There are 50 to 100 tentacles streaming off the creatures body. In the wild those tentacles lay about and look like various types of roots and vines.

**Normal Reaction and Attacking:** The creature tries to hug a victim in four or five tentacles and then move the captured body into a pod on the side of the creature. Then that pod is filled with dissolving juices that do 2d6 to the victim every hour until the victim is dissolved.

**Mutations or Defects:**

**AUDITORY SENSITIVITY** – The plant can hear movement up to 40 yards away. This allows the plant to better attack victims.

**DRAGGING VINES** – These specialized vines have a range of 30 feet. They wrap around a victim and drag them into the main body of the plant.

**HIDDEN ROOTS** – The plant has deeply buried roots within 20 yards. These roots rise up to squeeze a victim for 1d10 a combat round.

**TRAP MAT** – A mat of vines is placed over a deep pit. The vines open up to allow victims to fall in the deep hole. Other vines at the bottom of the pit eat the carcasses falling in.

---

## E – GRASSLANDS OF THE SINGING VINES

---

This is a tranquil place. A great deal of earth has settled into this area. There are tall grasses and wild flowers everywhere. At the center of this 100 yard by 150 yard area is a special atrium garden. 300 years ago this area supplied the seeds and plants that have flowed out of the atrium and onto the floor level of the apartment building.

At the center of the atrium is a cluster of ten singing vines. There is also one singing vine in all the corners of this area: northwest and northeast and southwest and southeast. The vines want the characters to stay in the area and defend the singing vines from the numerous attacks by ants and lizardmen. Although the player characters will not be able to attack the singing vines, they will be able to walk away whenever they want to.

The lights are kept functional by robots and the area is constantly lit in artificial sunlight. The atrium provides water for the entire area.

**Singing Vine** - AC: 8, hp: 33, Movement in Spaces: 3, Radiation Resistance: 17, CON: 6, Mental Resistance: 6, STR: 6, DEX: 6

**Appearance:** The singing vine is a nine foot tall sun flower creature with a quite human face in a huge flower petal. Its root system allows it to move slowly on the ground. There are several stalk hands that allow it to grasp objects. It moves slowly.

**Normal Reaction and Attacking:** The plant creature can move along at a steady pace and, when threatened, it emits barely audible sonic cry that prevent any creature or intelligent being from harming it. The vine

wants to use its sonics to tame creatures so that they stay around the singing vine and protect it.

### **Mutations or Defects:**

**CALMING SONICS** – The vine can emit a sonic up to twenty yards away that can't be resisted. It makes the targeted being, while in range, totally calm and unable to harm the singing vine. That being will do everything in their power to protect the vine from dangers.

---

## **WASHROOMS ON THIS LEVEL**

All of these washrooms are filled with intensity 15 radiation. There is no life in these areas. After opening the doors, one instantly notes the bright green glow of the radiation. No harm happens to the characters unless they step into the washroom.

---

## **E1 – GRASSLANDS ELEVATORS AND STAIRS**

This area is covered in tall grass. The stairs up are cleaned every day so plants don't grow there. On the stairs is a pair of red skull & crossbones flags. The elevators work fine. There are hardly ever any creatures in this area. On the right and left side of the stairs are wide corridors that gown down to a special set of seats looking down at the stage on the first level.

---

## **F – UPPER STAGE SEATING**

In this 100 yard wide by 180 yard long section of the apartment is a look down onto the stage of level one and the main floor. To the south of this area is a set of seats perfect for looking down on the stage. At 12 noon and 6 in the afternoon there are duels to the death on the stage below. If characters on the upper level throw down things or make attacks in the lower area, two security robots rise from the lower level and attack the transgressors.

### **SECURITY BOTS –**

Security bots are all 9 foot tall ovals of shiny silvery metal. The surface is smooth with lenses and tentacles hidden inside the body. There is a slight glow at the bottom for the anti-gravity system. They possess four 4 meter tentacles with paralysis fields, 2 visual lenses good up to 6 miles in light or dark, sound receptors good for 90 meters, gas pellet ejector with 4 magazines of 30 pellets each (12 intensity paralysis poison), Human action circuits, broadcast power receptors, emergency power cells good for 72 hours, Anti-grav propulsion, body armor for AC 2, energy shields worth 50 hit

points of force field generation, 2 slug ejectors with 6 magazines of 12 shots each (15 points of stun damage), radio circuits, 3 padded 12 meter tentacles, 4 lenses looking into the ultra-violet and infrared spectrums, 100 hit points, and mechanical circuitry allowing the robot to take over other mechanicals.

## **VISTA FLOOR**

### **A – LAIR OF THE ORANGE WOLFOIDS**

This entire section of apartments is controlled by the Orange Pirate wolfoids. The inner section of apartments is filled with wolfoid families. These chambers contain lots of furs of many types. There are orange skull and crossbones flags in this area. Strangers are allowed to come into the area, so long that they want to sign up and become Orange wolfoids. If they join up the captain of the Orange wolfoids sends the newly joined group down to fight in the duels at noon or 6. As members of the Orange wolfoids the characters are allowed to walk in the other sections of the apartments controlled by the red and blue wolfoids.

---

### **A1 – ORANGE WOLFOID CONTROLLED ELEVATORS & STAIRS**

There is a group of four Orange Pirate wolfoids constantly on guard in this area. Another group of four guards can be called at need. These guards take strangers to the central area where the Captain of the orange Wolfoids rests. This is a role playing experience where the characters can become a member of the crew. If characters say no, they are forced to walk the plank and fall 30 yards to the ground outside the apartments.

At any given time there are 30 adult Orange Pirate wolfoids moving in and out of the apartment complex. There 10 to 30 wolfoid pups being born all the time in this section of the apartments. The Orange wolfoids are the smallest pack of Wolfoids in this complex.

All of the inner apartments are connected to each other. Robots are not allowed in this middle section of apartments. There are several orange flags clustered on the outside edges of this area.

The outside apartments are empty and robots come cleaning and fixing things every day. On each bed in the outside apartments there are sets of immaculate Orange Pirate uniforms laid out for residences.

# PIRATE COMPLEX

## Map 4 Lido Floor

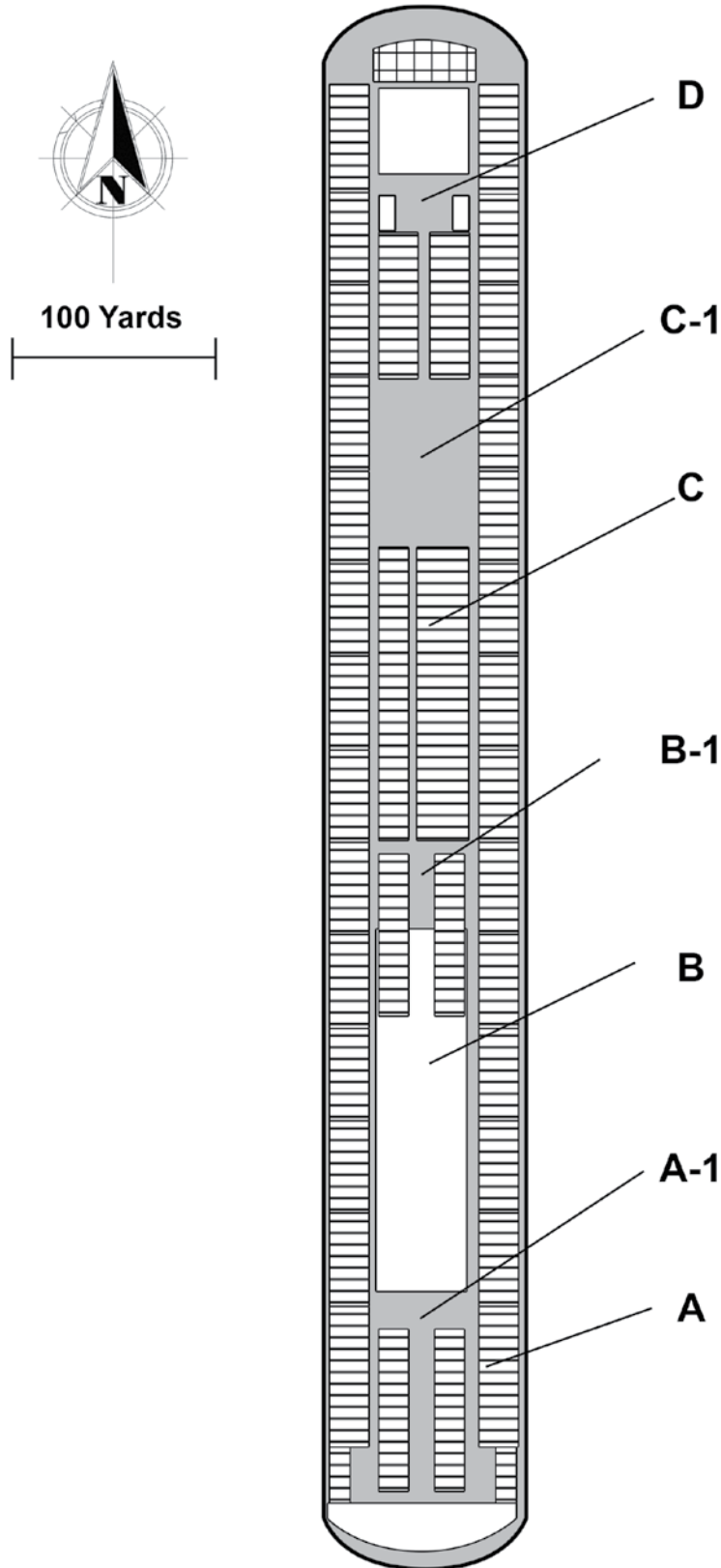

## B – RED WOLFOID LAIRS AND TRAINING AREA

The center apartments in the B and C sections are filled with Red wolfoid lairs. All of the apartments connect and are covered in furs. There are many red skull & crossbones flags hanging from sections of the ceilings in this entire area.

The large open area that is about 50 yards wide and 200+ yards long is a green grassed training area. In the early morning and late at night the Red wolfoids come and practice with their weapons. There are many mock duels that fight to the first touch. Any strangers that come into the training area are asked if they want to become red pirates. If they don't want to join they are forced to walk the plank out a side balcony; falling 30 yards to the street below.

If character party members become red pirates they are ordered to attack another wolfoid apartment complex across the city.

All of the outside apartments are clean and maintained by robots. There are Red wolfoids uniforms on each of the beds.

**You have come across some type of training area. There are targets and beat up humanoid manikins in the middle of the area. The entire place smells of gunpowder. There are racks of weapons of all types in the south section of the field. The floor is covered in green grass, smelling fresh and recently mowed.**

### B1 – RED WOLFOID ELEVATOR AREA

There are red skull & crossbones flags flying from the ceiling. The elevators and stairs are perfectly clean from the action of cleaning robots. There are always two Red wolfoid pirates as guards. These creatures have telepathy and ask if the characters have come to join the Red Pirates. If the characters say no, the two guards attack.

The characters can't go north or south from here without running into more Red pirate wolfoids. All of these ask if the characters want to join the Red Pirates. If the characters don't sign the pirate code and join, they are slain or, if captured, forced to walk the plank off one of their balconies, 30 feet above the ground.

## C – RED PIRATE WOLFOID AREA

Red flags fly from the ceilings all over this place. The two outside sections are pristine apartment cleaned by robots every day. All of the balcony doors are open. The balconies are filled with thick plants that are maintained by garden robots. In every tenth balcony there is a winged biter nest and the biter vehemently objects to characters coming into its apartment.

**Winged Biter** - AC: 4, hp: 19 Movement in Spaces: 12 flying/9 slithering, Radiation Resistance: 18, CON: 8, Mental Resistance: 17 STR: 10, DEX: 18

**Appearance:** The creature is six feet long with a three-foot wing span. Its flesh changes color to match its surroundings.

**Normal Reaction and Attacking:** The creature is highly aggressive. Its flesh is resistant to paralysis and poison. The snake spits intensity 13 level poison every other melee round.

### **Mutations or Defects:**

**POWER LEACH** – With skin-on-skin contact the mutant can absorb 1 random mutation from another mutant. This mutation stays for ten minutes.

**APATHY FIELD** – 4 times a day the mutant can make a mental attack to cause apathy. If the attack works the victim drops what each is holding and wanders away from the area.

### INSIDE C APARTMENTS

The inside apartments are all connected and filled with wolfoid lairs. No robots are allowed in this area. Each of these apartments is filled with furs. The captain of the Red wolfoids is at the center of this area. If the characters come this far they are talked to by the captain. If they are Red Pirates they are tasked with dueling at noon and 6 on the stage. If they are any other color, the Captain suggests they leave and explore elsewhere. If they aren't pirates, they are asked to join the Red wolfoids. If they don't want to do this and are captured by the guards, they are forced to walk the plank out of a balcony to fall 30 yards down to the street.

### C1 – RED PIRATE ELEVATOR AND STAIR AREA

Two red skull & crossbones fly on the ceiling of this area. The elevators and stairs are spotless and cleaned and fixed and maintained every day by robots. To the north is a set of stairs going up and down. There are

moveable chairs on the side walls for beings to ride up or down the stairs with the push of an armchair button. To the south is a large enclosure with brain teaching units. During the day this area is filled with young wolfoids learning about the city from the teaching units.

Two very young, guard Red wolfoids guard this area. They are willing to talk to player characters. The guards want to know if the characters want to sign the accords of the Red Pirates. If they do, the characters are taken to the captain. If the characters don't want to join they are lured to an ambush, where, if they are captured they will be forced to walk the plank off the balcony to the street 30 yards below.

### SLEEP-TEACHING AREA

There are four teaching machines in this area. They are cleaned and updated every day by the robots and insane A.I. of Epsilon City. It is a great secret of the Red wolfoids and only open to Red Pirates. The wolfoids and anyone else who hooks up is given a quick tour of the entire town and then can focus on one of the sections to know exactly what it looks like and what is currently in that area. The Red Pirates have taken great advantage of this teaching aid. They have picked up the easy-to-get equipment and now work on the more dangerous areas like other apartment complexes in Epsilon City.

### D – LIZARDMAN AREA

This section of the apartments is given over to the lairs of a different kind of mutant. The lizardmen have given their word to the wolfoid bands that they will be in the forefront of every battle if monsters, robots, and androids come to attack the dwellers of this apartment.

There are approximately 200 adult lizard creatures living in the inside apartments of this area. There is a fishy theme to this inner area and lots of fish head trophies hang from the corridor and apartment walls.

The outside apartments are cleaned and maintained every day by robots. On the beds of these apartments are placed large weighted nets and dangerously sharp tridents.

If the characters are dressed in pirate uniforms, they are left strictly alone. Even if the party members attack lizards, the lizards retreat in fear.

**Lizard Humanoid** - AC:2, hp: 25, Movement in Spaces: 20, Radiation Resistance: 17, CON: 10, Mental Resistance: 17, STR: 10, DEX: 10

**Appearance:** This creature is nine foot tall, with thick bright blue scales that help its armor class. They move amazingly fast.

**Normal Reaction & Attacking:** It can use mental attacks but prefers attacking with a man-trapping weighted net and a large trident. The trident does 4d6 with each successful strike. If the tridents are not striking and doing enough damage, the lizard uses its mental mutations in attacks.

#### Mutations or Defects:

**SHADOW JUMP** – This mutation allows the being to move from large shadow to large shadow in a line of sight teleportation.

**APATHY FIELD** – Four times a day in a 30 yard radius the mutant generates an apathy field. Failing a mental resistance roll victims drop what each is holding and wander off.

**DEACTIVATION** – This allows the mutant to turn off devices victims are trying to use.





## LIDO FLOOR

The wolfoids have deliberately planted a great deal of dangerous plant life on this level of the apartments. The idea is to have a buffer so that dangerous things flying into the area are attacked by the deadly plants.

### A – GRABBER FOREST

---

This portion of the apartments is well lit as the robots are still able to replace the lights. There are many trees in this area and one tree in every apartment. The grabbers remain still as characters approach their area and then plants start making attempts at grabbing the characters. The corridors here are free of plants and the wolfoids have conditioned the grabbers to never grab into the corridors.

In every chamber there are cast off devices and other articles that would be useful to have. These are designed to tempt the characters and were snagged by the grabbers and laid out from the bodies of the victims. Use the following list for random selection of items. A larger version of this list can be found in the CREATURES & GADGETS sourcebook on sale at the Goodman Games website.

TABLE 6-1: RANDOM ITEM LIST

| D20 | RANDOM ITEM               |
|-----|---------------------------|
| 1   | Animal Field Dressing Kit |
| 2   | Untearable Backpack       |
| 3   | Camo Uniform              |
| 4   | Canteen                   |
| 5   | Combat Helm               |
| 6   | Emergency Container       |
| 7   | Energy Stun Unit          |
| 8   | Fire Starter              |
| 9   | First Aid Kit             |
| 10  | Folding Shovel            |
| 11  | Force Axe                 |
| 12  | Force Baton               |
| 13  | Force Hammock             |
| 14  | Force Field Pack          |
| 15  | Force Field Tent A style  |
| 16  | Force Saw                 |
| 17  | Hiking Staff              |
| 18  | Laser Binoculars          |
| 19  | Light Cube                |
| 20  | Life Detector             |

**You have come into an area overgrown with willow trees. The trees have huge root systems and the branches reach up to the ceiling and spread out around the functioning lights of the ceiling. There are two corridors in this section of the apartment. You also see glints of metal everywhere among the roots of the trees.**

**Grabber Plant** - AC: 4, hp: 50, Movement in Spaces: 0, Radiation Resistance: 10, CON: 10, Mental Resistance: 10, STR: 10, DEX: 10

**Appearance:** Each one of the hundreds of these plants growing in this area looks like a willow tree. There are massive root systems supporting each Grabber. There are vine-like branches thickly hanging down from each tree. With one tree to each apartment, after 200 years the trees have become quite massive.

**Normal Reaction & Attacking:** These creatures use their branches and roots as ropes that drag in victims. An acid wash attempts to kill these victims. Their attack is with 5 tentacles. The acid bath only happens when the plant has pulled in the victim. Each vine or root takes 10 points of damage before breaking.

#### **Mutations or Defects:**

MANIPULATION VINES – Weapon Class 4 grabbing vines.

ACID BLAST – The plant can shoot acid from the center of the trunk. The acid does 4d6 points of damage. This acid can't miss if the victim is being held by the Grabber vines.

### A1 – ELEVATORS & STAIRS UP AND DOWN

---

This area is kept spotless by the robots and the wolfoids. The thought here is to trick intruders that all is calm on this level. The wolfoids want characters to explore here so that they are attacked by powerful mutation plants.

**The area is crystal clean. On the north end is a large stair extending up and down to other levels. The four elevator doors are clean and shiny steel. To the south is an open area extending into a forest area.**

### B – JAWED PLANT AREA

---

**This is a large open area that is filled with many jawed plants. The apartments in this area all have one large jawed plant. The plants are smart enough to let the characters come into the area before they are attacked.**

# PIRATE COMPLEX

## Map 5 Sky Floor

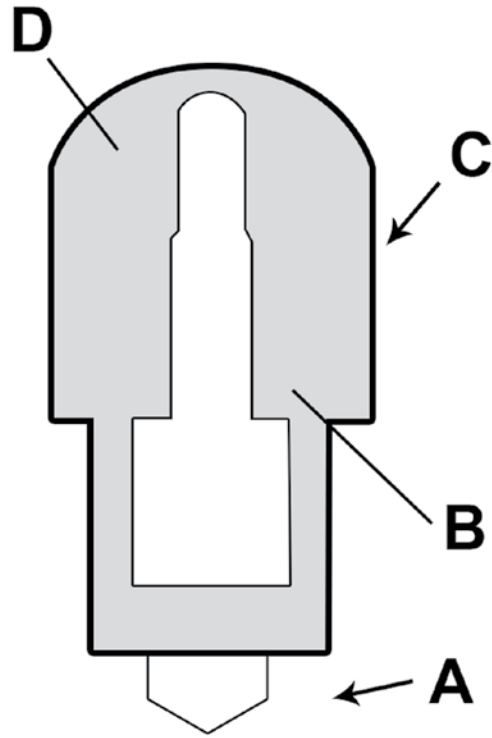

100 Yards



The area is filled with many large bushy plants. Many of the plants are moving as if there is a strong breeze, but you feel no breeze. The lights glow brightly in the ceiling.

**Jawed Plant** - AC: 4, hp: 18, Movement in Spaces: 6, Radiation Resistance: 9, Con: 9, Mental Resistance: 9, STR: 9, DEX: 9

**Appearance:** The jawed plant is a 9 foot tall Venus fly trap. The jawed part hides in a thick bush.

**Normal Reaction & Attacking:** When attacking the plants long neck reaches out 25 yards to attempt to grab a victim in its huge plant jaw pod. Once in the pod the acid does 20 points of damage a melee round.

**Mutations or Defects:**

MANIPULATION VINES – These allow the plant to slowly move across a surface.

JAWED PLANT POD – This five feet long pod reaches out like a fanged mouth to grab victims. Once grabbed acid pours out of the flesh of the pod and eats away at victims. The acid does 20 points a melee round.

**B1 – ELEVATOR & STAIR AREA**

This area is kept spotless and immaculate by the robots and the wolfoids. The thought here is to trick characters that all is calm on this level. The wolfoids want characters to explore here so that they are attacked by dangerous mutated plants.

The area is crystal clean. On the south end is a large stair extending up and down to other levels. The four elevator doors are clean and shiny steel. To the north is an open area extending into a strange pod plant forest.

**C – SWORD BUSH AREA**

The corridors in this area are all cleaned by robots every day. The plants have been conditioned to never move out of their apartments. Sometimes the bush is hiding in the washroom or other room of the apartment. Many times the plants want to attack out in surprise.

You are in some type of apartment complex. All of the apartment doors are open and you see beds and living rooms depending on the size of the suite. Many times you see the open area filled with a large bushy plant. There are cleaning robots cleaning in the corridor.

There are devices and other bits of armor and metal lying out in the open to tempt characters to go into the apartments and be attacked by the sword bush.

TABLE 6-2: RANDOM EQUIPMENT CHART

| D20 | RANDOM EQUIPMENT                         |
|-----|--|
| 1   | 5 hydrogen energy cells                  |
| 2   | Disruptor Pistol                         |
| 3   | Disruptor Rifle                          |
| 4   | Paralysis Rod                            |
| 5   | Duralloy Shield                          |
| 6   | Laser Pistol                             |
| 7   | Slug Projector                           |
| 8   | Gas Pellet Ejector                       |
| 9   | White Color Band                         |
| 10  | Broken Garden Robot                      |
| 11  | Sonic torch                              |
| 12  | Hasmat Suit                              |
| 13  | Two Dead Red Wolfoids                    |
| 14  | Large Backpack filled with Dried Food    |
| 15  | Jar of 12 Poison Contact Sap             |
| 16  | Large pile of white furs                 |
| 17  | Bundle of 7 metal javelins               |
| 18  | Stone Axe, Stone Dagger, Duralloy Shield |
| 19  | 2 Fragmentation Grenades                 |
| 20  | Infra-red Goggles with energy cell       |



**Sword Bush** - AC: 6, hp: 30, Movement in Spaces: 10, Radiation Resistance: 5, CON: 5, Mental Resistance: 18, STR: 5, DEX: 5

**Appearance:** The fern is highly intelligent. The out-sides of its branches are metallized leaves and act like swords. The bush can move these around to slash and stab at victims.

**Normal Reaction & Attacking:** When attacking the plants long neck reaches out 25 yards to attempt to grab a victim in its huge plant jaw pod. Once in the pod the acid does 20 points of damage a melee round. The bush never follows characters out of an apartment.

**Mutations or Defects:**

DEFECT – LIGHT SENSITIVITY

MANIPULATION VINES – These allow the plant to slowly move across a surface.

JAWED PLANT POD – This five feet long pod reaches out like a fanged mouth to grab victims. Once grabbed, acid pours out of the flesh of the pod and eats away at victims. The acid does 20 points a melee round.

TELEPORTATION – Once a day the plant can teleport to a location it has seen in the last two years.

PRECOGNITION – By doing nothing else, the plant can see up to 10 minutes into the future, once a day.

MENTAL CONTROL – The plant can make a mental attack to control the actions of an intelligent being for 60 minutes is the victim doesn't make their resistance roll. This attack can be made once a day.

FORCE FIELD GENERATION – For six hours the plant can raise a shield around itself. This shield takes 60 points of damage before allowing attacks on the surface of the mutant.

METALLIC LEAVES – There are 18 large metallic leaves that are able to stab and slash a victim. If the plant is doing nothing else it can make 3 attacks on any nearby foe.

LIFE ENERGY DETECTORS – The plant can automatically detect energy sources up to 30 yards away. This detection happens no matter what else the plant is doing.

---

## C1 – ELEVATORS & STAIRS UP AND DOWN

---

This area is kept spotless by the robots and the wolfoids. The thought here is to trick characters that all is calm on this level. The wolfoids want characters to explore here so that they are attacked by powerful mutation plants.

**The area is crystal clean. On the north end is a large stair extending up and down to other levels. The four elevator doors are clean and shiny steel. To the north and south is an open area extending into a clean corridor with open apartment doors.**

---

## D – PLANT MEN SECTION

---

The corridors and apartments in this area are trashed. There are many broken cleaning and security robots in the corridors. Every apartment is filled with rotting furniture and beds. There are ten to twenty of the small plant men in each apartment. In the center apartments are both larger sizes of plant humanoids. The small plant men think nothing of coming out of their rooms and attacking the group.

**You see wreck and ruin where ever you look. The corridors are filled with dried leaves at least a foot deep. There are broken robots in the corridors with smashed-in sides. The smell of mold and damp is so strong it makes it hard to breathe in this area.**

**Plant Humanoid #3** - AC:5 (3), hp:88, Movement in Spaces:10, Radiation Resistance:18, CON:18, Mental Resistance:11, STR:11, DEX:18

**Appearance:** This plant mutant is a humanoid standing 9 inches tall. It has thorns all over its body and can generate a 12-inch spear that it uses for attack and defense. It's smart enough to move around attack with some forethought.

**Normal Reaction and Attacking:** These plant humanoids start a battle using their spears. If foes prove deadly the plants use some of their mutations to defend themselves.

**Mutations and Defects:**

LIGHT SENSITIVITY – Plants can't move in the dark.

SMALL – These mutants much smaller than average.

TELEPATHY – This allows the plant to communicate with any intelligent being.

THORNS – Striking the body of this mutated plant with a hand or paw causes 2d6 in damage.

HEIGHTENED INTELLIGENCE – These plants are much smarter than normal vegetation. This helps them figure out technology.

## SKY ROOF SECTION

The roof of the apartment is a neutral place for the wolfoids and the lizardmen. It is enjoyed equally by all of the Pirate apartment tribes. The lizards come up to the roof in groups of ten and twenty during the day. The wolfoids do the same at night. There is to be no fighting on the roof and four security robots guard the area to make sure no one starts a battle.

### A – WATER PARK

---

The water park is just what it sounds like: it's an area 150 yards long and 75 yards wide. There are three large water slides, a huge wave pool, and several hot tubes of different sizes. At the four corners of the park are very large water cannon that have been used to fend off flying attackers in the past. The cannons shoot out large blasts of water that few creatures can defy (Strength 17), though they do little other than knock down victims.

### B – SERENITY FLOOR

---

This area is very tranquil and has lizards and wolfoids resorting to it at all hours of the day. There are drink and food stations with many types of meals. There are comfortable force field hammocks all over the area. As soon as beings appear soft, computer-generated music begins playing to calm wolfoids and lizard men so that they can't get angry or aggressive even if they wanted to when exposed to some type of threat. This section of the roof is also guarded by four security robots.

### C – SPA

---

The spa is a large chamber where steam gets heat up the area and beings are supposed to cleans in the heart. It is cleaned and repaired daily by the robots of the apartment complex. Ignorant player characters might consider this an attack form as jets of steam fill the chamber as beings enter the area.

### D – OPEN DECK

---

The open deck has several sports to be played. One of the most useful ones is shooting targets with shot-guns and laser guns. The shooting range's dedicated A.I. won't allow the weapons to hurt outsiders, using force fields as necessary. However, the weapons can be taken out of the area and used against beings anywhere. There is also a javelin tossing range with moving hologram targets of rabbits, deer, and bear.

## BESTIARY

### SECURITY BOTS

---

Security bots are all 9 foot tall ovals of shiny silvery metal. The surface is smooth with lenses and tentacles hidden inside the body. There is a slight glow at the bottom for the anti-gravity system. They possess four 4 meter tentacles with paralysis fields, 2 visual lenses good up to 6 miles in light or dark, sound receptors good for 90 meters, gas pellet ejector with 4 magazines of 30 pellets each (12 intensity paralysis poison), Human action circuits, broadcast power receptors, emergency power cells good for 72 hours, Anti-grav propulsion, body armor for AC 2, energy shields worth 50 hit points of force field generation, 2 slug ejectors with 6 magazines of 12 shots each (15 points of stun damage), radio circuits, 3 padded 12 meter tentacles, 4 lenses looking into the ultra-violet and infrared spectrums, 100 hit points, and mechanical circuitry allowing the robot to take over other mechanicals.

### UPGRADED SECURITY BOTS

---

These bots only appear in Epsilon City. These started out like normal looking security bots, but after many attacks by many mutants, they are darkened, dented ovals showing obvious signs of horrendous battle. These units have all of the specs of the normal security robot plus the following:

250 hit points, 150 hit points of force field generation, rotating blades that force foes to deal with 4d6 in blade cuts if foes try to engage in melee with the bot, and electrical blasts from the 3 padded tentacles doing 15 points of damage at a touch.

### ENGINEERING BOTS

---

These bots have a centaur-like shape with a working platform toed behind a humanoid robot. The robot can turn their torsos fully around and work on projects on the platform and still continue moving with their platforms in front of them.

They are equipped with independent action circuits, broadcast power, power cell for 24 hours of operation, telescopic and microscopic lenses with up to 50 times magnification, 3 lenses for infrared and ultra-violet viewing, 3 manipulating tentacles, 2 power grasping claws, two special tool manipulation tentacles, a selec-

tion of replacement parts, high propulsion unit, AC 6, 100 hit points, and communication units to talk with computer and verbal systems.

## ECOLOGY ROBOT "GARDEN" BOTS

This robot has a cube shape and is four yards by four yards by four yards tall. All manner of cutters, saws, shovels, and hoes come out of its surface. Operation tapes with special gardening instructions, energy cell power supply for 24 hours of operation, anti-grav unit for carrying objects up to 50 pounds, low propulsion unit, soil analysis sensors, fertilizer and chemical defoliants, horticultural tools, optical lenses as the forest model, insecticide and herbicide sprayers and tanks, audio and radio transmitters with vocal pickups, variable light sources, AC 3, and 75 hit points.

## CREATURES OF THE ADVENTURE

**Pirate Wolfoids** - AC: 3, hp: 60 x4, Movement in Spaces: 15, Radiation Resistance: 15, CON: 16, Mental Resistance: 12, STR: 12, DEX: 18

**Appearance:** These bipeds stand 9 feet tall and have manipulative paws. Their fur is bright red, suggesting some sort of mutation. Their eyes also glow bright red from its radiated eye mutation. One of the wolfoids has a green band, the sort that is needed to open an elevator in this complex.

**Normal Reaction & Attacking:** It takes very little to start a fight with these wolfoids. Pirate wolfoids all

bear a cutlass for a melee weapon and a single shot blunderbuss pistol for a ranged weapon, tucked into their belts. These pirates roar at any characters coming into the kitchen. They are clearly motioning strange characters to leave the area.

**CUTLASS** – Weapon Class 3, Damage 1d8/1d6/1d12

**BLUNDERBUSS PISTOL** – Weapon Class 5, Damage 3d6, Range (short) 10 yards, (medium) 11-30 yards, (long) 31-40 yards

### **Mutations or Defects:**

**MANIPULATIVE PAWS** – allows the mutant to handle any human built device.

**REFLECTIVE FUR** – Reflects all types of energy.

**CONTACT POISON RESISTANT** – Its fur resists all the affects of contact poison.

**REGENERATION** – This mutant regenerates 5 lost hit points per melee round.

**RADIATED EYES** – 14 intensity useable once per day

**Death Sphere** - AC: 6, hp: 56, Movement in Spaces: 8, Radiation Resistance: 15, CON: 8, Mental Resistance: 8, STR: 3, DEX: 17

**Appearance:** In adult form the sphere is 7 feet high and has a diameter of 6 feet. It's a sphere with lots of spore holes along its sides. Each section of spore holes blasts out a different type of spore depending on the hour of the day. The creature is able to slowly roll across most surfaces. Most spheres have the same coloring as their surroundings and are hard to see until a being is within 10 yards of the creature.



**Normal Reaction & Attacking:** The creature spews forth with one of its attacks and can sense foes up to 100 yards away.

**Mutations or Defects:**

**HEAT BREATH** – With a range of 5 yards this mutant fires a blast of flame for 5d6 damage once a day.

**ACIDIC VOMIT** – With a range of 1 yard this mutant blasts acidic vomit for 3d6 in damage once a day.

**HIVE HOST** – The hornet swarm attacks as a Weapon Class 1 with an armor class of 1 and a poison class of 3. 5d6 are rolled for the hornets and every 6 is a strike each melee round. They attack for three melee rounds and then go back into the mutant.

**INK EXPULSION** – The mutant generates a huge cloud of dark ink that stays suspended around the mutant with a range of 60 feet until a breeze blows the ink away. The mutant has the use of all of his senses within the ink cloud. He can generate this cloud once a day.

**SLIME** – The mutant generates extremely slippery slime three times a day. This slime is impossible to stand or walk through.

**Lizard Humanoid** - AC:2, hp: 25, Movement in Spaces: 20, Radiation Resistance: 17, CON: 10, Mental Resistance: 17, STR:10, DEX: 10

**Appearance:** This creature is nine foot tall, with thick bright blue scales that help its armor class. They move amazingly fast.

**Normal Reaction & Attacking:** It can use mental attacks but prefers attacking with a man-trapping weighted net and a large trident. The trident does 4d6 with each successful strike. If the tridents are not striking and doing enough damage, the lizard uses its mental mutations in attacks.

**Mutations or Defects:**

**SHADOW JUMP** – This mutation allows the being to move from large shadow to large shadow in a line of sight teleportation.

**APATHY FIELD** – Four times a day in a 30 yard radius the mutant generates an apathy field. Failing a mental resistance roll victims drop what each is holding and wander off.

**DEACTIVATION** – This allows the mutant to turn off devices victims are trying to use.

**Rope Circles** - AC: 4, hp: 100, Movement in Spaces: 10, Radiation Resistance: 16, CON: 18, Mental Resistance: 17, STR: 11, DEX: 8

**Appearance:** This plant creature can change colors to match its surroundings. An adult version is four feet

tall and has a diameter of 12 feet. There are 50 to 100 tentacles streaming off the creatures body. In the wild those tentacles lay about and look like various types of roots and vines.

**Normal Reaction and Attacking:** The creature tries to hug a victim in four or five tentacles and then move the captured body into a pod on the side of the creature. Then that pod is filled with dissolving juices that do 2d6 to the victim every hour until the victim is dissolved.

**Mutations or Defects:**

**AUDITORY SENSITIVITY** – The plant can hear movement up to 40 yards away. This allows the plant to better attack victims.

**DRAGGING VINES** – These specialized vines have a range of 30 feet. They wrap around a victim and drag them into the main body of the plant.

**HIDDEN ROOTS** – The plant has deeply buried roots within 20 yards. These roots rise up to squeeze a victim for 1d10 a combat round.

**TRAP MAT** – A mat of vines is placed over a deep pit. The vines open up to allow victims to fall in the deep hole. Other vines at the bottom of the pit eat the carcasses falling in.

**Winged Biter** - AC: 4, Hit Points: 19 Movement in Spaces: 12 flying/9 slithering Radiation Resistance: 18 Constitution: 8, Mental Resistance: 17, Strength: 10, Dexterity: 18.

**Appearance:** The creature is six feet long with a three foot wing span. Its flesh changes color to match its surroundings.

**Normal Reaction & Attacking:** The creature is highly aggressive. Its flesh is resistant to paralysis and poison. The snake spits intensity 13 level poison every other melee round.

**Mutations or Defects:**

**POWER LEACH** – With skin-on-skin contact the mutant can absorb 1 random mutation from another mutant. This mutational power stays for ten minutes.

**APATHY FIELD** – 4 times a day the mutant can make a mental attack to cause apathy. If the attack works the victim drops what he is holding and wanders away from the area.

**Bubble Frog** - AC: 8, Hit Points: 59 Movement in Spaces: 12 leaping/9 swamp Radiation Resistance: 13, Constitution: 13, Mental Resistance: 13, Strength: 13, Dexterity: 13

**Appearance:** The frog is fifteen feet long and has

a fanged mouth that can easily swallow a humanoid whole. There are 20-40 fist size bubbles around its body. Its flesh blends in with whatever terrain it is standing along side at the time.

**Normal Reaction & Attacking:** The creature is highly aggressive. Its flesh is resistant to paralysis and poison. It bites for 3d6. It is also smart enough to try pouncing on prey to hold them down and crush them with their weight. There is a 1-50% chance of bursting a bubble when trying to melee this creature. The bubbles have three different types of chemicals in them and the mutant is immune to all of the affects. Roll a d6 to determine what flies out of the bubble.

1-2 Intensity 15 poison contact spores

3-4 Acid mist doing 4d6 in an area around the frog and continuing to do this damage until a breeze blows the acid away.

5-6 An inky blackness in a 40-foot area around the mutant that the mutant can see right through.

**Mutations or Defects:**

**BUBBLE FUNGI POD** – The creature shoots out one of three different types of randomly chosen fungi when a random bubble is burst.

**Bubble Fox** - AC: 3, Hit Points: 89, Movement in Spaces: 16, Radiation Resistance: 14, Constitution: 16, Mental Resistance: 10, Strength: 10, Dexterity: 18.

**Appearance:** This fox is four feet tall at the shoulders and seven feet long. There are 20-40 fist-sized bubbles protruding from its body. Its fur and skin blends in with whatever terrain or surfaces it is standing along side at the time.

**Normal Reaction and Attacking:** The creature is highly aggressive. It bites for 2d6 damage. There is a 1-50% chance of bursting a bubble when trying to melee this creature. The bubbles have three different types of chemicals in them and the mutant is immune to all of the affects. Roll a d6 to determine what flies out of the bubble.

1-2 Intensity 9 radiation

3-4 Vomit inducing spores with a 1-40% chance of making a victim helpless for 2 combat rounds.

5-6 An inky blackness in a 40-foot area around the mutant that the fox can see right through.

**Mutations or Defects:**

**BUBBLE FUNGI POD** – The creature shoots out one of three different types of randomly chosen fungi when a random bubble is burst.

**Black Ant Mutant** - AC:5, Hit Points: 77, Movement in Spaces: 12, Radiation Resistance: 17, Constitution: 17, Mental Resistance: 4, Strength: 18, Dexterity: 10

**Appearance:** These giant black ants are four feet long, and three feet tall at the shoulder. They move quickly, wherever they go. They make an odd clackety-clackety sound as they move and this can be heard for up to 100 yards away. Their pincers are huge and constantly in motion. They are strong enough to cut down large trees with one pincer motion.

**Normal Reaction and Attacking:** Their pincer cuts for 6d6 of damage with each successful strike.

**Mutations or Defects:**

**HEIGHTENED SPEED** – The mutant can make two attacks per combat round.

**MOLECULAR STAGNATION** – Twice a day, after a successful strike the mutant drains all the power from the victim and his or her devices when struck. The victims have their batteries drained to zero energy. If they are using broadcast energy devices those units are broken. With each drain the mutant gains 6 hit points.

**PROTECTIVE COATING** – This protective coating is used to firm up the sand and give the walls and ceiling of the tunnels an armor class of 4. The walls created have a sort of varnish on them and seem very hard. It only takes 3 hit points of break through this coating

**Singing Vine** - AC: 8, Hit Points: 33, Movement in Spaces: 3, Radiation Resistance: 17, Constitution: 6, Mental Resistance: 6, Strength: 6, Dexterity: 6

**Appearance:** The singing vine is a nine foot tall sun flower creature with a quite human face in a huge flower petal. Its root system allows it to move slowly on the ground. There are several stalk hands that allow it to grasp objects. It moves slowly.

**Normal Reaction and Attacking:** The plant creature can move along at a steady pace and, when threatened, it emits barely audible sonic cry that prevent any creature or intelligent being from harming it. The vine wants to use its sonics to tame creatures so that they stay around the singing vine and protect it.

**Mutations or Defects:**

**CALMING SONICS** – The vine can emit a sonic up to twenty yards away that can't be resisted. It makes the targeted being, while in range, totally calm and unable to harm the singing vine. That being will do everything in their power to protect the vine from dangers.



**Grabber Plant** - AC: 4, Hit Points: 50 Movement in Spaces: 0, Radiation Resistance: 10, Constitution: 10, Mental Resistance: 10, Strength: 10, Dexterity: 10

**Appearance:** Each one of the hundreds of these plants growing in this area looks like a willow tree. There are massive root systems supporting each Grabber. There are vine-like branches thickly hanging down from each tree. With one tree to each apartment, after 200 years the trees have become massive.

**Normal Reaction & Attacking:** These creatures use their branches and roots as ropes that drag in victims. An acid wash attempts to kill these victims. Their attack is with 5 tentacles. The acid bath only happens when the plant has pulled in the victim. Each vine or root takes 10 points of damage before breaking.

**Mutations or Defects:**

**MANIPULATION VINES** – Weapon Class 4 grabbing vines.

**ACID BLAST** – The plant can shoot acid from the center of the trunk. The acid does 4d6 points of damage. This acid can't miss if the victim is being held by the Grabber vines.

**Jawed Plant** - AC: 4, Hit Points: 18, Movement in Spaces: 6, Radiation Resistance: 9, Constitution: 9, Mental Resistance: 9, Strength: 9, Dexterity: 9

**Appearance:** The jawed plant is a 9-foot tall Venus fly trap. The jawed part hides in a thick bush.

**Normal Reaction & Attacking:** When attacking the plants long neck reaches out 25 yards to attempt to grab a victim in its huge plant jaw pod. Once in the pod the acid does 20 points of damage a melee round.

**Mutations or Defects:**

**MANIPULATION VINES** – These allow the plant to slowly move across a surface.

**JAWED PLANT POD** – This five feet long pod reaches out like a fanged mouth to grab victims. Once grabbed acid pours out of the flesh of the pod and eats away at victims. The acid does 20 points a melee round.

**Sword Bush** - AC: 6, Hit Points: 30, Movement in Spaces: 10, Radiation Resistance: 5, Constitution: 5, Mental Resistance: 18, Strength: 5, Dexterity: 5

**Appearance:** The fern is highly intelligent. The outside of its branches are metalized leaves and act like swords. The bush can move these around to slash and stab at victims.

**Normal Reaction & Attacking:** When attacking the plants long neck reaches out 25 yards to attempt to grab a victim in its huge plant jaw pod. Once in the pod the acid does 20 points of damage a melee round.

**Mutations or Defects:**

**DEFECT – LIGHT SENSITIVITY** –

**MANIPULATION VINES** – These allow the plant to slowly move across a surface.

**JAWED PLANT POD** – This five feet long pod reaches out like a fanged mouth to grab victims. Once grabbed acid pours out of the flesh of the pod and eats away at victims. The acid does 20 points a melee round.

**TELEPORTATION** – Once a day the plant can teleport to a location it has seen in the last two years.

**PRECOGNITION** – Doing nothing else, the plant can see 10 minutes into the future, once a day.

**MENTAL CONTROL** – The plant can make a mental attack to control the actions of an intelligent being for 60 minutes if the victim doesn't make their resistance roll. This attack can be made once a day.

**FORCE FIELD GENERATION** – For six hours the plant can raise a shield around itself. This shield takes 60 points of damage before allowing attacks on the surface of the mutant.

**METALLIC LEAVES** – There are 18 large metallic leaves that are able to stab and slash a victim. If the plant is doing nothing else it can make 3 attacks on any nearby foe.

**LIFE ENERGY DETECTORS** – The plant can automatically detect energy sources up to 30 yards away. This detection happens no matter what else the plant is doing.

**Plant Humanoid #3** - AC:5 (3), Hit Points:88, Movement in Spaces:10, Radiation Resistance:18, Constitution:18, Mental Resistance:11, Strength:11, Dexterity:18

**Appearance:** This plant mutant is a humanoid standing 9 inches tall. It has thorns all over its body and can generate a 12-inch spear that it uses for attack and defense. It's smart enough to move around attack with some forethought.

**Normal Reaction and Attacking:** These plant humanoids start a battle using their spears. If foes prove deadly the plants use some of their mutations to defend themselves.

**Mutations and Defects:**

**LIGHT SENSITIVITY** – Plants can't move in the dark.

**SMALL** – These mutants much smaller than average.

**TELEPATHY** – This allows the plant to communicate with any intelligent being.

**THORNS** – Striking the body of this mutated plant with a hand or paw causes 2d6 in damage.

**HEIGHTENED INTELLIGENCE** – These plants are much smarter than normal vegetation. This helps them figure out technology.

# A65 THE ATILA ARMS APARTMENT COMPLEX

BY MICHAEL CURTIS

The designers of the Attila Arms Apartment complex dreamed of creating a fantastical-historical simulation where the residents would gleefully indulge in mock battles in raids no more dangerous than collegiate pranks. The intended residents were horse-lovers: equestrians, horse-breeders and racing aficionados. The Huns were chosen as a famous, equine-oriented culture with a distinctive aesthetic. They couldn't have dreamed they were planting the seeds that would grow into a far more lethal harvest. In the wake of the catastrophe, the Attila Arms Apartment complex has become home to a tribe of wolfoids who take the fun and games far more seriously—and ruthlessly—than anyone could have imagined. The Hun wolfoids ride out across Epsilon City and its outskirts, ambushing and murdering anyone unlucky enough to cross paths with the horde before returning to their fortified headquarters at the Attila Arms Apartment building.

## THE HUN WOLFOIDS

The mutant wolves of this complex are perhaps the most savage of all their brethren living in Epsilon City. The Hun wolfoids care only for battle and plunder. They have utterly embraced the Hun lifestyle and mindset, going so far as to deform their skulls in childhood to achieve the ideal of Hunnish beauty.

The Hun wolfoids are a filthy lot: their clothes and possessions are dirty, worn and used until they fall apart, and their fur is matted and ridden with fleas and louses. Outsiders spending a prolonged period of time amongst the Hunnish wolves find themselves scratching constantly at these vermin. The Hun wolfoids don't seem to mind.



What the Hun wolfoids do seem to mind are robots. The entire tribe harbors an irrational hatred for the metallic occupants of the city and have done their best to eradicate them from the building. A few battered survivors prowl the sections unvisited by the Hun wolfoids, but these are rarities. Broken fragments of plastic and battered metal parts are often found amongst the filth of the complex, a testament to the dire fate awaiting any mechanical creature entering the building.

The Hun wolfoid tribe is currently led by Octar, a leader respected by his Hun brethren and feared by all others. The Hun wolfoids have accumulated a great deal of wealth and resources under Octar's command and support him fully. Nearly a thousand Hun wolfoids follow his lead, confident Octar will continue to satiate their thirst for blood and plunder.

The Hun wolfoids have a deep love for their mounts and ride whenever possible. They regularly take their mounts for gallops down the corridors of the apartment building for sport. PCs exploring the building might randomly encounter these riders in the most unlikely of places. While all Hun wolfoids are adept riders, the most skilled are the elite Sky Riders. These elite own oversized pegasi and are the most respected equestrians of the tribe. Octar uses them as shock troops in raids, diving from above to scatter enemies and prevent escape.

---

## RELATIONS WITH OUTSIDERS

---

The Hun wolfoids view anyone other than themselves as potential prey, victims to be robbed then either enslaved or slain depending on how the mood strikes them. They regularly launch lightning-swift horseback strikes against the other wolfoid tribes and the various mutant residents of Epsilon City, and even ride outside of the city in search of plunder. Almost universally, the Hun wolfoids are despised and/or feared, and their utter destruction would be a blessing to the residents of Epsilon City.

Recently, however, Octar has made tentative efforts to broaden relations with outsiders. Betting on the Hun wolfoids' reputation as warriors and raiders, Octar has extended offers to a handful of other wolfoid tribes, offering the services of his people in battle in return for a lion's share of the spoils. He has approached the Viking, Cherokee, and Roman wolfoid tribes with limited success, although Jarl Gunnhild of the Viking wolfoids

is considering employing the Huns as mercenaries in her scheme to take the Pirate Apartments for her own kingdom.

The Hun wolfoids, despite the attempt to establish business relationships with outsiders, remain aloof and view any creature encountered within their walled enclave as intruders in need of slaying. Under no circumstances will the Hun wolfoids accept outsiders into their ranks as anything other than slaves, and these subjugated workers have short lifespans. Sooner or later, prisoners end up dead when the Huns grow bored and seek violent, bloody entertainment.

---

## HUN WOLFOID HORDES

---

The Hun wolfoids regularly ride out from their home to slay and pillage, assembling in large mounted groups. Deadliest when atop their fast-moving chorse mounts, a Hun wolfoid horde is a terror to behold.

An average horde consists of 1d100+50 chorse-mounted Hun wolfoids lead by a sub-chieftain. These smaller assemblies range out 1d3 times a week, engaging in raids of opportunity, striking anyone or anything unfortunate enough to cross their path.

Roughly once per month, a much larger horde leaves the complex to strike a predetermined location. These more numerous groups are comprised of 1d6+1(×100) mounted Hun wolfoids accompanied by a full contingent of 20 Sky Riders and their mounts. These raids are personally led by Octar and always return laden with plunder and slaves.

---

## THE SQUEAKS

---

The apartments are home to a second sentient species of mutants, a race of altered rats who call themselves the squeaks. Perhaps they dwelt here prior to the wolfoids claiming the apartment for their own, or maybe the squeaks were attracted by the perpetual squalor in which the Hunnish wolves live. In either case, the rats are here and are intent on staying.

The squeaks have numerous lairs and sub-lairs throughout the apartment complex. Most of these nests are hidden throughout the building's ducts, maintenance shafts, subflooring, and other inaccessible regions. It's therefore nearly impossible to bring a fight directly to the squeaks, ensuring that so long as the complex remains standing, the mutant rats will endure.

These labyrinthine networks of passages also make the squeaks excellent guerilla fighters, able to attack without warning in seemingly well-defended sections of the building and quickly disappear if the fight turns against them.

The mutant rats secretly desire the apartment building for themselves, seeing their society as superior to the Hun wolfoids. This makes them potential allies for PCs exploring the complex. With their uncanny knowledge of the complex's layout, the squeaks could easily help smuggle the PCs inside the building and help them avoid detection once in. The squeaks would demand a portion of whatever treasures the PCs liberate from the Hun wolfoids and ultimately full ownership of the building, but aren't prone to betraying the explorers as long as they too keep up their end of any bargain.

## THE ATTILA ARMS APARTMENTS

### APARTMENTS IN THE ATTILA ARMS COMPLEX

The living quarters comprising the apartment building range in size to accommodate single residents to large families. Many are occupied, but others are empty or ruined. It is left to the referee to determine what sort of apartment(s) the PCs encounter as they explore the complex.

All the apartments contain common features, furnishings, and decorations, and, unlike the public spaces outside (see below), have contemporary designs. Each apartment holds one or more large screen tri-d view-screens, a spacious washroom with shower (both sonic and water) and hot tub, walk-in storage closets, a compact but fully equipped kitchenette, and one or more comfortable bedrooms. Doors to the apartments are sometimes open (75% chance) and sometimes closed (25% chance). Closed doors require red, white, or gray color bands to open (or brute force).

One closet in each apartment contains object replicator units capable of creating simple clothing and objects. Each is programmed to craft rough leather and fur garments tailored in Hun fashion, a sword, and a compound Hun bow with 20 arrows. A control panel inside the closet commands the replicator units and can produce additional clothing and simple Hun-lifestyle objects if used properly (Complexity 5).

## GENERAL BUILDING FEATURES

The Attila Arms Apartments were modeled after the famed Hunnish leader's personal dwellings according to historical records and are opulent in comparison to the savagery of the building's current occupants. Walls, floors, and ceilings of public spaces are made of synthetic wood paneling resembling planed timber planks bearing decorative swirls and patterns in the woodgrain, buffed to a high gloss. The floors are covered with thick carpets and rugs woven from soft, durable plastic fibers that withstand steady wear-and-tear. These floor coverings all sport Persian designs and Eastern European patterns. Lighting is achieved with faux candles that provide soft illumination throughout the building, but emergency lighting is also present, designed to activate in the case of power loss or a building-wide emergency to aid evacuation and rescue workers.

Stairs are constructed from wood. The stairways are broad and deep, making them easy to ascend, and powered seats are located on either side of the stairwell to assist the elderly or infirm. Additionally, an inclined plane runs alongside the staircase, making it possible for horses to ascend and descent the staircases, a feature the Huns, with their mounted-lifestyle, find infinitely useful. Elevators throughout the building are large enough to accommodate a half-dozen horses and riders, and can be summoned by anyone with a color band.

## ENTERING THE APARTMENT

The Attila Arms Apartment complex was once easily accessible, but the Hun wolfoids' fortification of the building has limited access.

**Road:** A wide road surrounds the building, connecting it to other sections of Epsilon City. PCs traveling the road are likely (85% chance) to encounter small mounted groups of 2d6 Hun wolfoids leaving the area or returning from raids.

**Balconies:** Every apartment along the exterior of the complex possesses a small balcony. These outdoor spaces often held tiny gardens or decorative plants, many of which have mutated and grown. Flying mutants or PCs equipped with the proper tools can easily ascend to a balcony of their choosing.

The plants on the balcony are 75% likely to be normal aside from their increased size and vitality. The rest of the time, however, the balcony is occupied by mutant life forms. Roll on the table below to determine the occupant:

**TABLE 7-1: ATTILA ARMS BALCONY OCCUPANT**

| DIE ROLL | OCCUPANT           |
|----------|--------------------|
| 1        | Jawed Plant (1)    |
| 2        | Singing Vine (1)   |
| 3        | Red Stingers (1d3) |
| 4        | Stabbers (1d4)     |
| 5        | Hawkoids (1d6)     |
| 6        | Blood Bird (2d4)   |
| 7        | The Black One (1)  |
| 8        | Radiation Vine (1) |

**Impact Site:** In addition to the balconies, there is a jagged hole blasted in the eastern side of the apartment building on Level Four. An air transport vehicle malfunctioned and slammed into the structure many years ago and the damage was never repaired. Any flying or climbing creature can enter the building proper through this damaged region, but doing so leads them into tangler territory (see area 4-5).

**Main Floor:** The ground level of the apartment complex is ringed by a crude palisade wall of broken vehicles and uprooted tree trunks sharpened to points. Two gates allow entrance, but both these and the wall proper are watched by the Hun wolfoids. Stealthy PCs may be able to scale an unwatched section of the wall if they move quickly in-between patrols.

**Empress Floor:** The second level of the complex has a broad walkway surrounding it. This area once served as a parking ring for air transports, but they have all been destroyed or lost. A timber palisade surrounds the southern sundeck and is guarded, and these watchmen will easily spot flying PCs approaching during daylight hours.

**Sky Floor:** The complex roof is open to the sky and can be accessed by flying creatures. There are hazards atop the building, however, including a primitive artillery piece manned by wolfoids to fend off flying attackers.

**ATTILA ARMS APARTMENT EXTERIOR FEATURES**

The bottom floor of the complex was once open on all sides to allow residents and visitors easy access to all the building’s amenities. The Hun wolfoids have put an end to such ready accessibility by erecting a crude defensive wall around the base of the building and limiting access to certain well-guarded gates. Initially, Epsilon City’s robotic units would dismantle the

barricade, but a mixture of negotiating with the building’s A.I. and wanton, destructive violence on all robot units approaching the complex ended this nuisance.

The Attila Arms Apartment complex is a four-story structure that’s seen better days. An aerial transport crashed into the building’s fourth level sometime after the catastrophe struck the *Warden*, blasting a large hole in the eastern side of the complex. Fire-damage and shattered windows adjacent to the impact site are still evident and nearby balconies are structurally comprised. The gaping hole has allowed strange mutants to occupy the upper level of the apartment building, but they seldom trouble creatures that avoid their territory.

The bottom level of the building is surrounded by a defensive palisade crudely constructed from tree trunks harvested from parkland throughout Epsilon City and supplemented by the wrecks on many aerial transport vehicles that were once parked in the vicinity of the complex. The Hun wolfoids destroyed these conveyances with the same ferocity they demonstrate on robotic units and dragged the damaged vehicles into position around the building. At night, burning torches are present atop the palisade, providing illumination for the guards to see by and giving the entire lowest level of the building a savage, hellish glow.

**LEVEL 1: MAIN FLOOR**

**AREA 1-1 –CRUDE PALISADE WALL:**

**A defensive wall measuring 20’ high surrounds the entire building, enclosing the formerly open bottom floor. The palisade is fashioned from hewn trees and smashed vehicles piled together. The trees trunks are sharpened to a point, creating a crenulated top to the entire wall. Movement along the walls indicate watches are posted to deter intruders.**

The wall is 10’ thick at the base, but only 2’ wide further up. The palisade can be breached with weapons (treat as AC 4, 200 hit points), blasting a 5’ wide by 8’ tall hole in the fencing. A wooden parapet runs along the interior of the wall and it is spottily patrolled by eight Hun Wolfoids. A pair of guards passes by any given point on the palisade once every fifteen minutes, meaning quick and stealthy enemies might be able to scale the wall without detection in places out of sight of the gates (areas 1-6 and 1-10) and the guard post on the second level (areas 2-1).

# ATTILA ARMS APARTMENTS

(Hun Wolfoids)

Map 1: Main Floor

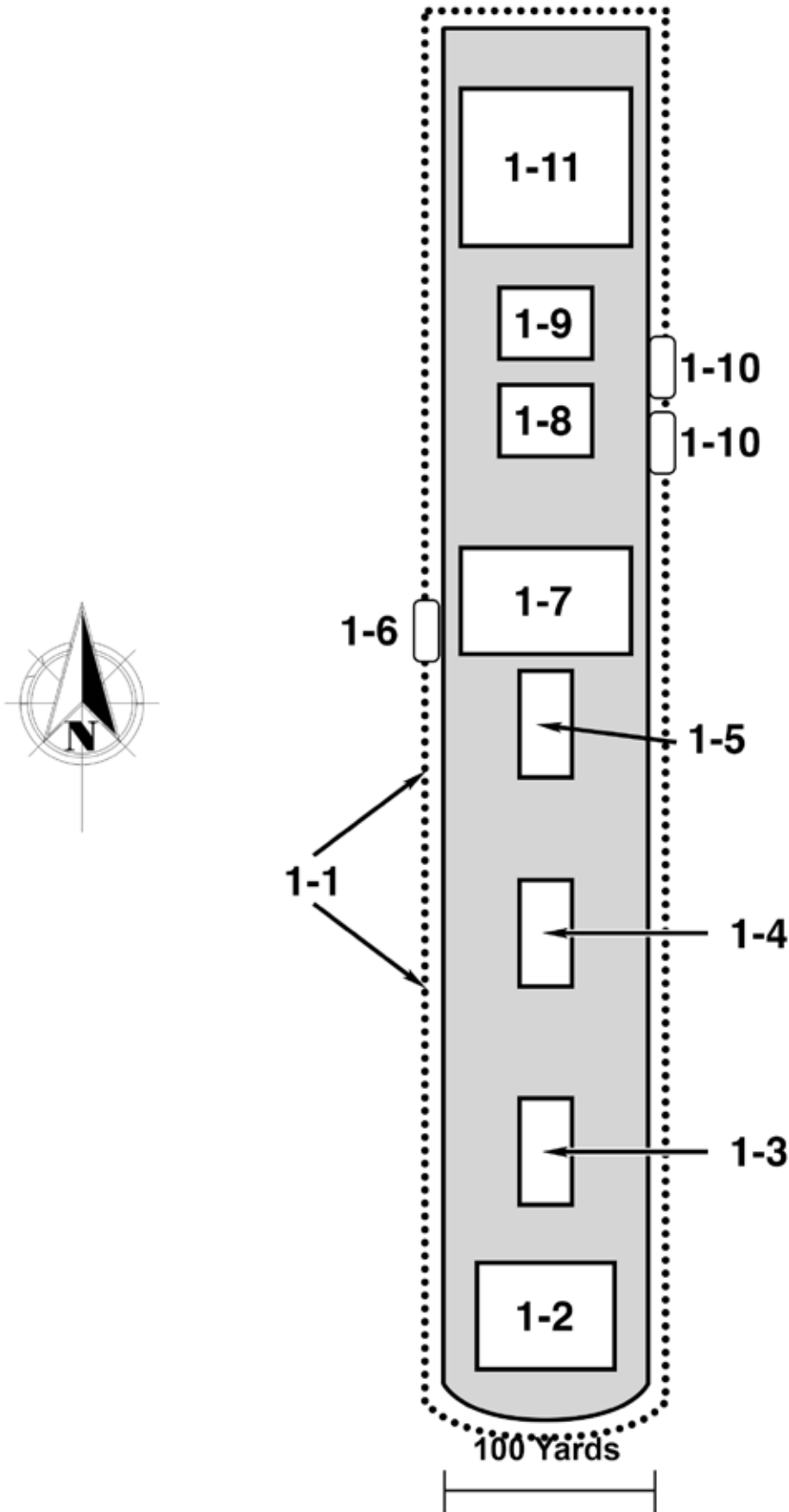

**Hun Wolfoid (8)** - AC: 5 Movement in Spaces: 16, Hit Points: 65 each, Radiation Resistance: 14, Constitution: 17, Mental Resistance: 11, Strength: 14, Dexterity: 17

**Appearance:** These wolfoids are monstrous in appearance. The Hunnish wolfoids practice cranial deformation, giving them elongated skulls and granting them a menacing visage. They stand 8' tall and are never encountered outside the apartment complex without their horses. Hun wolfoids wear light armor made from soft leather and quilted cloth.

**Normal Reaction and Attacking:** Hun wolfoids despise all other creatures aboard the *Warden*, and typically attack outsiders without hesitation. They fight mounted whenever possible, utilizing their compound bows and lassos to attack from a distance with devastating effect. When forced to fight on foot, they wield swords and bows.

#### **Special Weapons:**

**Hun Compound Bow:** The Hun wolfoids use a short compound bow, perfectly-sized for employment while mounted, and possessing significant strength over the typical short bows found on the *Warden*. Treat these compound bows as light crossbows when determining WC, damage, and/or entries on the alternate hit/miss ranged table (MA p. 19).

**Lasso (WC 1, dmg none).** Wolfoids use lassoes as a devastating weapon. They throw these ropes around opponents then ride swiftly past them, using the force of their mounts to injure or kill their enemies. Any creature struck by a lasso must roll its Dexterity score or less on 4d6. A successful roll means they are ensnared by the lasso, but have an arm free with which to possibly free themselves. A failed roll means they are utterly ensnared by the lasso with arms pinned to their sides. Should the roll result tally 20 or more, the lasso settles around their neck. Lassoed targets are automatically pulled off their feet and dragged when the mount rides on. Being dragged inflicts 2d6 damage each round the victim remains entangled and pulled along by the horse. The damage is increased to 4d6 if the victim is lassoed around the neck. The lassos are AC 7 and possess 6 hit points should a creature attempt to sever the rope.

#### **Mutations or Defects**

**RADIATED EYES:** Hun wolfoids can emit blasts of Intensity 10 radiation up to 30 feet once every 4 melee rounds.

**PHYSICAL REFLECTION (SLUG PROJECTORS):** The rubber slugs of riot control weapons have

no effect on Hun wolfoids and ricochet in a random direction. Anyone firing a slug projector at a Hun wolfoid must roll a 1d6. On a result of a 1, the slug ricochets back and hit the attacker.

**EQUESTRIAN GENIUS:** Hun wolfoids enjoy a +4 bonus to attack rolls while on horseback and inflict an additional die of damage on a successful hit.

The walls provide cover to those behind it, granting AC 3 versus ranged attacks.

---

### **AREA 1-2—FORMER CAFE:**

**Broken tables and chairs piled into mounds against the palisade wall indicate this was once an eating establishment. It is now a filthy ruin. Dirt covers the floor, the air reeks of unwashed fur, and blood and other less savory substances stain the walls and even the ceiling. A crude walkway runs atop the debris piles, allowing those inside to see over the protective wall.**

A group of twenty Hun wolfoids stand watch in this area, defending the southern approach to the complex from invaders. When the tribe goes raiding, only ten guards are found here. The guards are easily bored and prone to lackadaisical observation. Creatures approaching this region under the cover of darkness are 90% likely to reach the palisade without being noticed by either the guards stationed here or on the sundeck above (area 2-1), making this the best place for intruders to enter.

The palisade provides AC 3 against ranged attacks to any wolfoid (or smaller creature) standing behind it.

---

### **AREA 1-3—SOUTH ELEVATORS:**

**A quartet of metal doors flanks either side of this short hallway. A flight of broad stairs with adjacent inclined plane stands to the north, ascending to the upper levels of the building. The lighting is intermittent as ceiling panels flicker on and off. A half dozen short spears are driven into the floor, each crowned with the battered metal head of a robot.**

These elevators and stairs are never watched given their close proximity to the guards at area 1-2. The 'bot heads are from a security robot, butler robots, and standard general purpose robots, all of which were destroyed by the Hun wolfoids and placed here as a warning. The heads no longer function and are useless.

## AREA 1-4—FORMER KITCHEN:

---

**A few broken pieces of machinery and once-gleaming metal surfaces are piled near the palisade surrounding this wide, long, open expanse. A carpet of scraggly grass grows from the broken duracrete floor and a large herd of mutant beasts possessing traits of both cat and horse nibble on the blades. The air is thick with the smell of horsehide and manure.**

The Hun wolfoids demolished the kitchen that once stood here, transforming the now-cleared space into a rough meadow to house their numerous horses. The few remaining kitchen appliances no longer function. Three hundred mutant horses known as chorses fill the space.

**Chorses (300)** - AC: 6, Hit Points: 60 each, Movement in Spaces: 20, Radiation Resistance: 13, Constitution: 15, Mental Resistance: 6, Strength: 16, Dexterity: 16

**Appearance:** Chorses appear to be a hybrid between horse and cheetah, giving them a sleek feline appearance with equine features and a spotted pattern to their fur. A partial carapace covers vulnerable portions of their anatomy, acting as a natural barding.

**Normal Reaction and Attacking:** Chorses are bred to be hardy mounts and are unaffected by fire, loud noises, or similar effects that disturb animals. They are loyal mounts and are immune to fear when bearing a rider. Chorses can attack to defend themselves and at the command of their rider, lashing out with claw-tipped hooves (WC 3; dmg 1d10/1d10/1d12).

### **Mutations or Defects:**

**PARTIAL CARAPACE:** The chorse has a base AC of 6. In addition, there is a 2 in 6 chance any attack striking them hits their carapace, reducing the damage taken by half.

**NEW BODY PART (EFFICIENT STOMACH):** Chorses can survive on only a fraction of the food a horse normally requires. This makes it easy to feed them on the scant vegetation found inside the apartment building. Additionally, their stomachs process poisons effectively, making chorses immune to poison effects from consumed substances.

There are ten Hun wolfoids here charged with clearing the manure and tending to the horses. Youngsters, they are desperate to prove themselves as warriors. If they detected intruders, their first response is to leap

atop a chorse and ride down the interlopers rather than sound an alarm. If dispatched quickly, the intruders may escape detection from the Hun wolfoids stationed nearby.

A crude water pump linked to the building's water pipes fills many long watering troughs along the western wall of the area. Also present are grooming supplies for maintaining the horses, sacks of oats, hay, and similar foodstuffs, and a curious green plastic device the size of a Twentieth Century remote control. This object is a veterinarian medical unit. The Complexity 3 device heals 6d6 damage to any mutated creature, but is 75% likely to do the same amount of damage to true humans and mutated humanoids. The device requires 2 hydrogen cells and can be used six times before these need replacement.

## AREA 1-5—CENTRAL ELEVATORS:

---

**Four metal doors stand here, two to each side of the short hallway. A flight of stairs with adjacent inclined plane ascends to the south of the doors, leading to the building's upper levels.**

If no alarm has been sounded and the wolfoids are unaware of intruders, three Hun wolfoids stand guard here, lounging lazily, sharpening their swords, and passing a drinking skin filled with kumis back and forth. They spring to attention if intruders are sighted, rushing into battle while raising a howling alarm. Their cry likely alerts nearby wolfoids if they haven't been already dealt with.

## AREA 1-6—WESTERN GATE:

---

**A single tower rises above the palisade surrounding the building's base at this point. A 10' wide closed door stands in the middle of the tower, restricting access inside the compound. A handful of furred humanoids man the top of the tower, peering over its crenelated timber walls.**

This small gate allows smaller groups of Hun wolfoids to come and go. It is manned by four Hun wolfoids at all time, each armed with compound bows and swords. A hollow wooden log can be pounded to summon reinforcements in case of an attack. The palisade provides protection against attacks originating outside of the walls, granting the guards an AC 3 against ranged attacks.



The door is less impressive than the one at area 1-10. It is AC 6 and has 100 hit points. It lacks the firing ports found in the other gate, and attackers can move adjacent to it with only fear of attacks coming from the guards atop the tower proper.

---

### AREA 1-7—MARSHALING GROUND:

---

**This area shows signs of purposeful destruction. Tables, chairs, and counters lie in pieces piled against the surrounding palisade walls. The tile floor is cracked and the odd pile of horse manure awaits clearing. A single wooden tower with inset gate stands in the palisade to the west.**

Once a restaurant, the Hun wolfoids have cleared the space to serve as a marshaling ground. They gather their horses here and assemble their forces before riding out to raid other residents of Epsilon City. This area is usually empty unless a raid is imminent. There is a 15% chance the wolfoids are planning one each day the PCs are exploring the complex. In such cases, there will be a small horde of 50+1d100 wolfoids and mounts assembled here, primed for battle.

---

### AREA 1-8—RESIDENT LOBBY:

---

**Trashed and ruined furnishing lie in scattered piles around the open area, indicating it was once a place for people to gather and socialize. A battered circular bar surrounded by bent bar stools sits in the center of the space. The carpeting is stained and torn, and a pair of high wooden towers flanks a massive door to the east. Giant furred humanoids are organizing bundles and boxes to the west.**

The former lobby serves as an antechamber to the apartment complex, a place where slaves and plunder are processed and inventoried for the glory of the tribe. Fifteen Hun wolfoids are here currently organizing the profits from a recent raid. Combat with them is 90% likely to attract the attention of the gate guards at area 1-10 unless the battle is quick and quiet.

The bar is empty of potables and the taps no longer function. Broken glassware litters the floor behind the bar.

The boxes and bundles contain an array of plunder. Much of it is clothing, common tools, rope, and similar useful yet worthless objects. Mixed amongst them and located after a search of ten minutes or more are 278

domars, 15 hydrogen energy cells, five brown color bands, two white color bands, a red color band, 3 slug projectors and 10 full clips for them, a vibro axe, two pairs of sound elimination headphones, a space suit, and a laser pistol with a full charge.

---

### AREA 1-9—NORTHERN ELEVATORS:

---

**A sextet of metal doors stand here positioned just to the south of a wide staircase with adjacent inclined plane. The stairs and ramp are partially blocked by rubble and debris, and the metal doors are dented, scratched, and appear disused.**

These elevators and stairs are no longer functional due to the damage inflicted by the air transport colliding with the building's upper level. The lifts do not respond to color bands and, if pried open, reveal crushed and unpowered elevator cars.

The stairwell can be navigated with effort, but the fallen debris cluttering the stairs must be bypassed by smaller sized mutants or shifted out of the way. Moving the debris makes a great deal of noise and will attract 2d6 Hun wolfoids curious about the noises.

---

### AREA 1-10—EASTERN GATE:

---

**A pair of spiked log towers flanks a large timber doorway. The door measures 20' wide and 20' tall. Two small firing ports pierce the door's face. Furred humanoids armed with bows and strange metal staves man the tower tops, carefully on watch.**

This gate is one of two that allow entrance into the complex and is guarded at all times. A cadre of 10 Hun wolfoids (five in each tower) stands watch and opens the door when tribe members arrive and depart.

The wolfoids are armed with swords and compound Hun bows, but also possess four laser rifles amongst them. Two wolfoids in each tower are armed with these artifacts and each has a full charge in its energy cell. The southern tower also has a hollow wooden log that can be struck as an alarm, alerting all the wolfoids on Level 1 as needed.

The door is AC 5 and has 200 hit points should intruders attempt to blast their way in. The two firing ports in the door measure 1.5' high and 6 inches wide. They grant any creature firing from behind them AC 1 against physical attacks.

## **AREA 1-11—EXECUTION AUDITORIUM:**

---

**A dimly-lit auditorium filled with tiered seating facing a barren stage is here. The floor and seats of the space are splattered with a gray, chalky substance. Old footprints are visible through the dry matter. The flutter of wings is heard overhead.**

The Hun wolfoids have little use for music or theatre and instead utilize this space as an execution chamber. Prisoners or criminals are disposed of by forcing them into the auditorium and locking them inside. The intrusion agitates the mutant bats known as dats who roost overhead in area 2-9. The trespasser is swiftly slain by the dats as the wolfoids watch through the door windows looking inside the auditorium. The remains of the executed individual are removed in the evening when the dats are off hunting.

Any creature entering this area during daylight hours attracts the notice of the dats in area 2-9 above, who attack as detailed in that area's description below, flying down in waves each round until the intruder is slain. The dats are not present during evening hours and this room can be entered without peril.

Due to the regular clearing of the remains of executed victims, this space contains no objects of value or interest. The chalky gray matter is dried dat guano.

## **LEVEL 2: EMPRESS FLOOR**

### **AREA 2-1—SUNDECK:**

---

**The southern end of the apartment building is open to the elements, allowing its former residents to bask in the artificial sun above Epsilon City. Destroyed chaise lounges, overturned tables, and other smashed furnishings litter the area. A low wooden wall, crenelated with firing ports, rings the edge of the deck overlooking the streets below.**

The wolfoids use this area as a defensive emplacement, stationing a number of their tribesmen here with their fierce compound bows. These guards can rain bloody death down on anyone seeking to attack the complex, supplementing their arrow barrages with a case of scavenged grenades. There are eight Hun wolfoid guards stationed here at any given time.

The defensive wall surrounding the sundeck provides extra protection to the guards from attacks originating

beyond it. Treat the wolfoids as AC 3 versus ranged attacks from outside the complex.

In addition to their swords and bows, these wolfoids keep a foam-lined crate containing twelve grenades: six fragmentation grenades, four stun grenades, and two green smoke grenades. The wolfoids know how to use the grenades, but cannot discern between their types. They're just as likely to hurl a smoke grenade at attackers as a fragmentation grenade, and the referee should randomly determine the type hurled in the heat of battle.

### **AREA 2-2—SOUTHERN ELEVATORS:**

---

**A quartet of metal doors flank the corridor, a pair to each side. North of the doors, a set of open stairwells containing both stairs and ramp ascend and descend, granting access to various levels of the complex.**

These elevators are seldom guarded. There is only a 25% chance two Hun wolfoids are present here each time the PCs enter the area. They carry normal weapons and armor.

### **AREA 2-3—NIGHTCLUB AND LOUNGE:**

---

**Raucous laughter and loud howls echo from this dimly light area. Torn and faded padded benches and chairs surround scarred tables lit by flickering candles. A dirty bar covered with cups and glasses stands before a filthy mirror and poorly-stocked shelves. Numerous Wolfoids drink and carouse in the gloom.**

This club once served the apartment's residents, but is now the Hun Wolfoids' main watering hole. The building's A.I. provides unlimited quantities synthihol, but the Wolfoids prefer potent potables with a much stronger kick and make their own kumis or consume raided alcohol stolen from rival tribes.

There are always 1d20+20 Hun wolfoids here at any given time. They are highly inebriated, prone to violence, and have a -2 penalty to all attack rolls, but receive a +2 bonus to damage rolls due to their rowdy, drunken state.

## AREA 2-4—MAKESHIFT INFIRMARY:

---

The walls of these interconnected rooms are plain white and not the buffed timber planks found elsewhere. Metal shelves line the walls; many are empty, but others hold jars, boxes, canisters, and other bric-a-brac. Several beds and bed-like furnishings dominate most of the floor space.

Formerly storerooms, these connected rooms have been transformed into a crude infirmary and surgery space to treat wounded Hun wolfoids. The area contains a mixture of primitive medicinal treatments such as herbal remedies, poultices, and needles and sinew for stitching wounds, as well as some advanced medical supplies looted during raids.

Five Hun wolfoid healers are present at all times and an additional 1d8 injured wolfoids undergoing treatment are recuperating in the beds. The healers are also skilled warriors and fight to defend their charges.

Amongst the various panaceas and placebos found on the shelves are three first aid kits, four animal dressing kits, a paralysis rod (used for anesthetic purposes), and a jar of dried berries that heal 3d6 damage but negate the eater's mental mutation for 1d6 hours. Two of the bedlike furnishings are healing tubes, but due to its erratic effects on mutant creatures, the wolfoids seldom employ them.

## AREA 2-5—CENTRAL ELEVATORS:

---

**Smashed bottles and broken crockery litter a short, filthy corridor at this point. Four metal doors, their exteriors discolored by stains and bearing numerous scratches, flank the hall, two to each side. A wide flight of stairs with adjacent inclined plane leading both upwards and down stands to the south.**

Four inebriated Hun wolfoids are gathered here playing a variation of bowling. Skulls of enemies filled with sand and sealed with wax are rolled down to hall, striking bottles, jars, and other breakables much to the enjoyment of the players. Due to their pastime and drunken state, they are surprised on a 3 in 6 chance. They suffer a -2 penalty to attack rolls, but enjoy a +2 bonus to damage due to their drunkenness.

## AREA 2-6—BANQUET HALL:

---

This space is filled with small tables and chairs standing close to the walls to leave an open area in the center of the room. A raised platform containing an opulent couch and other small tables and chairs overlooks the open space. The floors are bare wood that shine with a glossy finish.

Formerly a restaurant, the Hun wolfoids now use this space as a banquet hall when the tribe gathers in large numbers. Up to 500 occupants can fill this eating space comfortably. The raised platform and opulent couch is reserved for Octar, with his seconds-in-command and numerous wives joining him there.

This area is seldom used and there is only a 5% chance a banquet is underway while the PCs are exploring the complex, usually in celebration of a particularly successful raid or Octar taking a new mate. If feasting is in progress, the hall is filled with 3d100+100 Hun wolfoids, all armed and intoxicated. Wolfoid dancers provide entertainment in the cleared center of the room, interrupted by the occasional brawl or ritual duel. Octars watch the proceedings warily accompanied by 20 wolfoids of lesser rank and privilege. A PC interrupting the banquet is likely doomed, overwhelmed by angry wolfoids.

**Octar, Chieftain of the Hun wolfoids** - AC: 4, Movement in Spaces: 16, Hit Points: 90, Radiation Resistance: 14, Constitution: 18, Mental Resistance: 16, Strength: 16, Dexterity: 18

**Appearance:** Octar appears no different than his followers physically, but his garments are cleaner and in better repair, and he carries himself with the cool composure of a leader who does not feel he must prove his superiority; it is simply fact.

**Normal Reaction and Attacking:** Octar loves a good fight but is also a cunning strategist. He sees no need to sacrifice himself if his followers can achieve what he desires without his direct intervention. When he does deem it necessary to act, he wields a standard Hun compound bow, a protein disruptor pistol, and a vibro blade.

### **Special Weapons:**

Hun Compound Bow: Treat as light crossbow when determining WC, damage, and/or entries on the alternate hit/miss ranged table (MA p. 19).

### **Mutations or Defects:**

**RADIATED EYES:** Hun Wolfoids can emit blasts of

# ATTILA ARMS APARTMENTS

## Map 2: Empress Floor

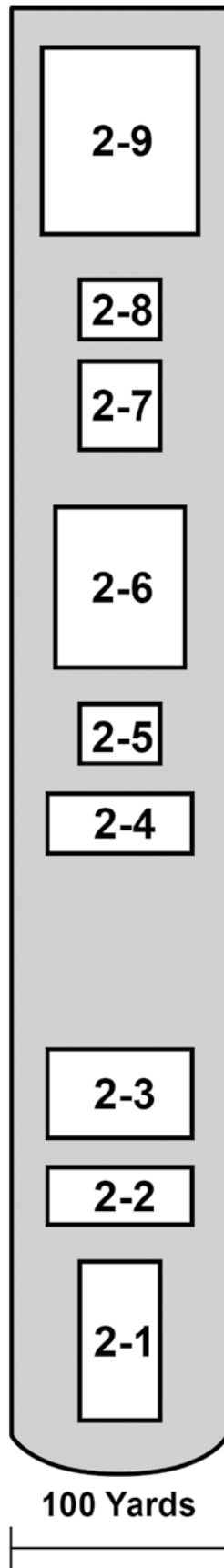

Intensity 10 radiation up to 30 feet once every 4 melee rounds.

**PHYSICAL REFLECTION (SLUG PROJECTORS):** The rubber slugs of riot control weapons have no effect on Hun wolfoids and ricochet in a random direction. Anyone firing a slug projector at a Hun wolfoid must roll a 1d6. On a result of a 1, the slug ricochets back and hit the attacker.

**EQUESTRIAN GENIUS:** Hun wolfoids enjoy a +4 bonus to attack rolls while on horseback and inflict an additional die of damage on a successful hit.

**CUNNING ENEMY:** Each round Octar battles an opponent, he gains greater insight into his enemy's combat style. Every round after the first, Octar gains a cumulative +1 bonus to hit that foe. This bonus is lost should he ever switch to another opponent or the battle ends.

## AREA 2-7—ROMAN BATHS:

**Dirty, dusty marble is evident everywhere in this area. Pillars of the same rise to the ceiling and murky bathing pools take up much of the floor space. Once opulent, this bathing area is now obviously disused.**

Designed to replicate the Roman bath Attila the Hun had built for his own pleasure, this bathing area was popular amongst the apartment's former residents, but is unused by the filthy Hun wolfoids. Now, other inhabitants have made it their home: six mutant mudpuppies known as dirtmouths lurk just beneath the surface of the pools, waiting to strike from surprise. Amphibious creatures, they attack any target coming within 20' of their watery lairs.

**Dirtmouths** (6) - AC: 6, Hit Points: 50 each, Movement in Spaces: 10 crawling/ 12 swimming, Radiation Resistance: 16, Constitution: 12, Mental Resistance: 7, Strength: 14, Dexterity: 13

**Appearance:** Measuring 6' long and possessing six legs, dirtmouths are mutated mudpuppies, equally adept at moving on dry land and swimming in the filthy waterways they call home. They have colorful external gills resembling ostrich plumes that wave wildly about to produce an unusual effect. Dirtmouths are mostly black or brown with dark blue spots, but rare albinos are sometimes encountered.

**Normal Reaction and Attacking:** Dirtmouths are ambush hunters, lurking in crevices or beneath murky waters and striking from surprise. They surprise prey on a 4 in 6 if their targets rely on sight, hearing, or

smell to detect enemies. If their prey is surprised, the dirtmouth gains a +2 bonus to its attack roll. The mutant salamanders possess unhygienic mouths which grant them both their name and their preferred attack form. A dirtmouth's bite is WC 3 and inflicts 2d6 damage. Additionally, the bacteria and filth present in their mouth is Strength 10 poison.

### **Mutations or Defects:**

**POISONOUS SLIME:** Dirtmouths secrete a slick mucus that makes them slippery and allows them to squeeze through small spaces. The slime is also Strength 16 poison if consumed.

**BLINDING GILLS:** By waving their feathery external gills and succeeding in a mental attack, dirtmouths can cause a single target capable of seeing the salamander to be struck blind for 2d6 turns. Blind opponents suffer a -4 penalty to all sight-based attack rolls and enemies enjoy a +4 bonus to hit them in turn.

The pools contain the remains of former meals. Searching the dirty 5' deep baths uncovers a first aid kit, a backpack containing six tubes of universal food paste, a light cube, a Geiger counter, a laser rifle (no power remaining), and a rusting suit of chainmail.



## AREA 2-8—NORTHERN ELEVATORS:

---

**Battered metal doors flank a short dirty corridor lined with marble. A staircase, partially blocked by collapsed flooring, stands to the north.**

The elevators are non-functional, damaged by the collision on Level Four. They do not respond to color bands and anyone opening them discovers a dark elevator shaft beyond. The bottom of the shaft is 50' below and it rises 100' up. The stairs can be traversed by smaller mutants, but man-sized or larger creatures need to clear the debris. Doing so creates a great deal of noise and is 75% likely to attract 2d6 Hun wolfoids curious about the racket.

## AREA 2-9—DATS' ROOST:

---

**A large mezzanine overlooks a performance space below. Rows of upholstered seating, now torn and dirty, run down towards the edge of the balcony in descending tiers. The space here is dark and the air smells foul as if heavy with waste and less identifiable scents. Somewhere in the dark, wings flap softly.**

This upper level of the auditorium is situated 40' feet above area 1-11 below. It is home to a colony of mutant bats. These creatures, called "dats," are shy, but intruding into their territory agitates them with lethal consequences.

**Dats (50)** - AC: 4, Hit Points: 12 each, Movement in Spaces: 15 flying, Radiation Resistance: 9, Constitution: 4, Mental Resistance: 8, Strength: 4, Dexterity: 18

**Appearance:** Dats are oversized brown bats measuring 2' long and possessing 5' wingspans. Their fur is iridescent black and their eyes shine blazing orange when their *sonic dissonance* mutation is in effect. They hunt in groups with 1d3+2 dat teaming up to attack a single creature.

**Normal Reaction and Attacking:** Dats are nocturnal and seldom venture outside of their roost during the day. At night, they leave their lair in great swirling clouds, spilling out a crack in the building's eastern wall and fanning out across Epsilon City to feed. They return home sated and sleepy. The dats almost never bother the Hun Wolfoids so long as they wolves keep out of their lair. Any creature who enters this area automatically rouses 3d6 dats who immediately attack. Another 1d6 dats enter combat each subsequent round until all 50 are awake and battling. Dats have a bite attack (WC 2; dmg 1d6/1d6/1d8).

### **Mutations or Defects:**

**SHADOW JUMP**—Dats can use shadows to instantly move from place to place within line of sight silently and undetected. In darkness or gloomy conditions, this allows them to attack prey from unexpected directions, granting them a +2 bonus to their attack rolls.

**SONIC DISSONANCE**—The mutant creates a subsonic noise that injures living flesh. One the first round, any creature within 20" aside from other dats or those immune to sonic attacks suffer 1d6 damage. On the following round, the damage increases to 2d6+8. Subjects suffer 3d6+12 damage on the third round. This ability then cannot be used for 24 hours. The dats act in concert when possible and this damage is multiplied by the number of mutant bats in range.

The seats in this area are covered by a thick layer of bat guano and numerous harmless insects scuttle about the place. Partially covered by the excretions is a trio of wolfoid skeletons and a decaying bearoid. These mortal remains have two compound bows with 24 arrows, a sword, a duralloy shield, a backpack with a first aid kit, canteen, and three hydrogen cells, and a folding shovel.

## LEVEL 3: VISTA FLOOR

### AREA 3-1: HUN WOLFOID APARTMENTS:

---

**A long corridor flanked by countless doors runs as far as your eyes can see. The air stinks of fur, filth, and cooking meat. The sound of growling voices is dimly heard from many of the open doorways and shadowy figures move in the distance.**

The majority of the Hun wolfoids dwell in these areas, spread throughout the complex in small family groups. Families of 2d10 wolfoids live in 2d4 adjacent apartments, occasionally mingling in the common areas (areas 3-2), the nightclub (area 2-3), or the banquet hall (2-6). When Octar announces a raid, the numerous families claim their mounts and gather on Level One.

There are 300 wolfoids in each of these areas but most are family groups living some distance apart. Stealthy PCs might be able to sneak through these section unnoticed, but loud combat, alerts, or similar disturbance rouse the wolfoids who quickly rush to the source of the disturbance. Reinforcements numbering 3d20+10 wolfoids soon descend upon the intruders.

## AREA 3-2: COMMON AREAS:

---

Many open doorways surround a filthy, open area that shows signs of regular usage. Meat roasts over barrels-turned-fireplaces, animal pelts and blankets serve as sleeping areas, and numerous saddles, weapons, and other belongings are scattered about. A score or more wolfoids are engaged in various domestic tasks.

These two sections of the complex are used as communal spaces by the Hun wolfoids. Each is fouled with dirt, waste, and trash, and the stench is horrible. The Hun wolfoids here immediately take up arms and attack intruders if they are unaccompanied by fellow tribesmen.

Each space typically holds 30 Hun wolfoids, but this number is reduced to 10 when a horde is out raiding. The Hun wolfoids present vary in age and gender, but they are all formidable opponents:

Each of these areas contains typical domestic tools and supplies such as cooking implements, raw meats, dried fruits, etc. in quantities capable of feeding 100 creatures for two weeks. In addition to these mundane objects, the southern common area have two animal dressing kits, six fire starters, 10 canteens, two force hammocks, ten tubes of universal food paste, and a light cube. The northern common area contains a box with six pepper spray grenades, four light cubes, a crate of 100 tubes of universal food paste, a first aid kit, two gray color bands, six canteens, and two chemical fire retardants.

## AREA 3-3—SOUTHERN ELEVATORS:

---

A quartet of metal doors flank the corridor, a pair to each side. North of the doors, a set of open stairwells containing both stairs and ramp ascend and descend, granting access to various levels of the complex.

These elevators are seldom guarded. There is a 45% chance 1d6 Hun wolfoids are present here each time the PCs enter the area. They carry normal weapons and armor.

## AREA 3-4: GRAZING MEADOW:

---

A broad expanse of green grass grows in this vast open area. Artificial sunlight illuminates the

meadow and a faint breeze originating from unseen sources ruffles the grass. Numerous mutated creatures resembling hybrids of horse and cat graze on the meadow, their rumps marked by scars and painted symbols of unknown origin.

The Hun wolfoids quarter many of their chorse mounts here when not raiding outside the complex. The grass grows well in this area, a former recreational sports arena and the chorses are well-fed and safe from rustling and mutant attacks. The markings on the chorses' rumps are brands identifying each mount with its owner. There are 400 chorses present here.

In addition to their mounts, there are also 1d20+10 Hun wolfoids present, grooming their chorses, riding them around the meadow, or simply enjoying the open space. They are armed and armored and don't suffer outsiders to leave here alive.

A number of equipment lockers stand against the western wall. These once held sports equipment, but now contain tack and saddles for the mounts. One locker sill contains sporting equipment and protective pads. If this equipment is properly worn (Complexity 7), they grant the wearer AC 4. There is enough equipment to outfit six humanoid creatures.

## AREA 3-5: DAMAGED AREA:

---

The ceiling in this area bulges downward and the walls are buckled and scorched. Pools of rusty water collect on the floor and stray wires dangle from the uneven ceiling. Six metal doors stand in the center of the area; three are open to reveal blackness beyond. A debris-filled stairwell stands to the north.

The collision on the level above severely compromised the structural integrity of this area. It is avoided by the wolfoids for fear of collapse. They pass down the corridors that flank this section with caution and a soft tread when traveling to and from the apartments and common area in the northern end of the building.

Anyone exploring this area has a 2 in 6 chance of triggering a hazardous event. The type of event is determined by the referee, but possibilities include contact with a live wire, falling through a hole in the floor, or triggering a ceiling collapse. The event inflicts 3d6 damage to 1d6 randomly chosen PCs if more than one character is exploring the area when the event occurs.

# ATTILA ARMS APARTMENTS

## Level 3: Vista Level

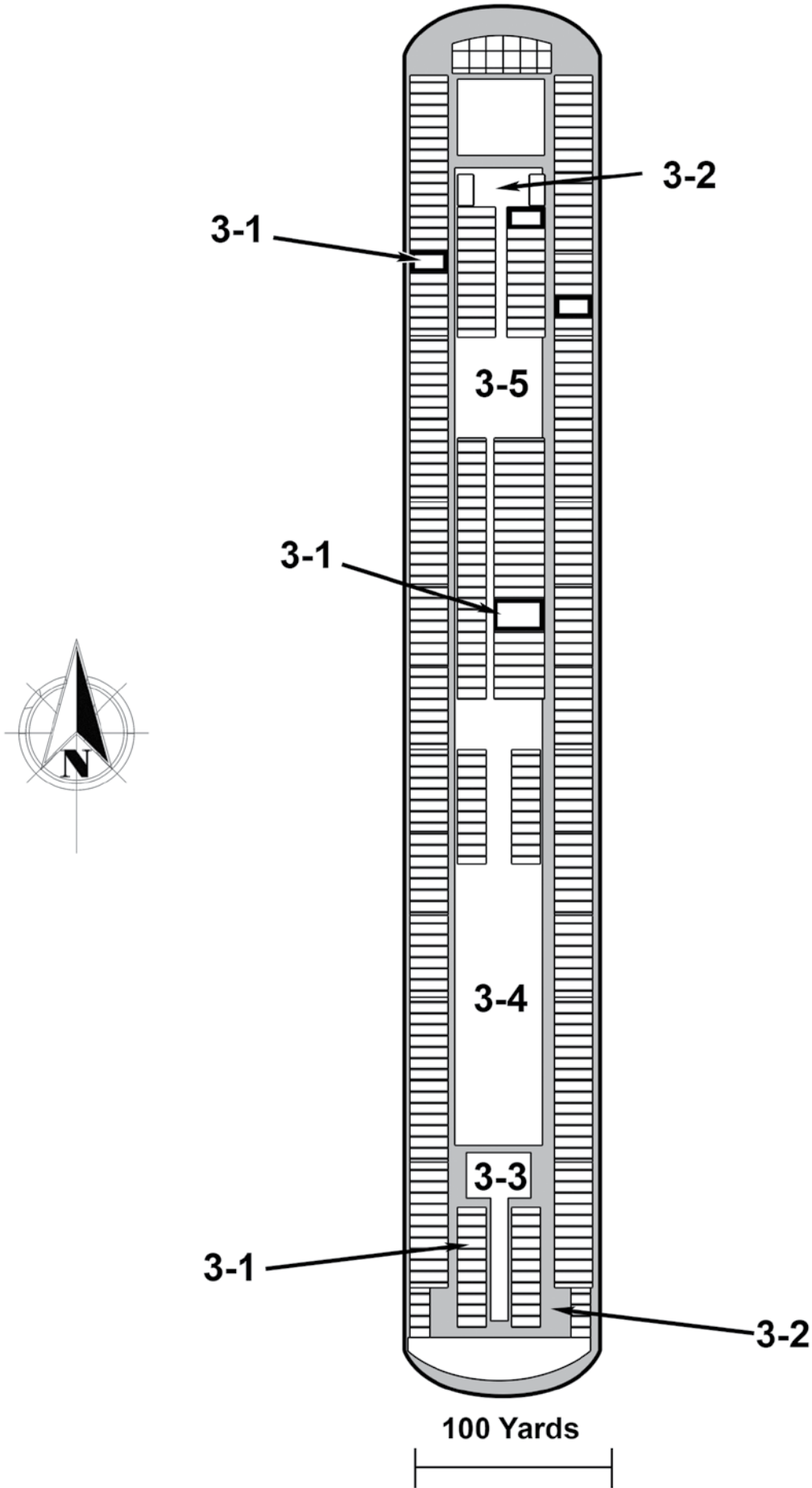



## LEVEL 4: LIDO FLOOR

### AREA 4-1—SOUTHERN ELEVATORS:

---

**Two pairs of metal doors face each other on opposite sides of this short corridor. A wide stair/inclined plane combination stands to the south, providing access to the other levels of the building. Something moves out of the corner of your eye, too fast to observe clearly.**

A trio of thief beasts lurks in this area, using their mutations and a pair of paralysis rods to waylay travelers and rob them of their artifacts.

**Thief Beasts (3)** - AC: 7, Hit Points: 35 each, Movement in Spaces: 8, Radiation Resistance: 13, Constitution: 10, Mental Resistance: 16, Strength: 10, Dexterity: 14

**Appearance:** Thief beasts are mutated raccoons standing 4' tall. They move on two legs and possess adept, humanoid hands that allow them to utilize the artifacts they incessantly crave.

**Normal Reaction and Attacking:** The creatures use their *telepathy* and *empathy* to determine what might intimidate travelers through the area, then employ their *illusion generation* power to create the image of a threatening opponent. This illusion is what the PCs glimpse out of the corner of their eyes when entering this area. The exact nature of this illusion is left to the referee's devising.

While the travelers are focused on the false seeming, the thief beasts sneak up on them and use their paralysis rods to incapacitate them. Once paralyzed, the thief beasts rob them of any interesting objects before fleeing. In addition to their paralysis rods, the creatures also carry a protein disruptor and a laser pistol, but will only seek to kill if they are left with no other option.

#### **Mutations or Defects**

**EMPATHY:** The creature senses all true humans, mutated humanoids, mutated creatures, and mutated plants within 30 yards as well as their current emotional state. This mutation does not allow the creature to read minds, only identify emotional moods such as anger, fear, hunger, happiness, etc.

**TELEPATHY:** The mutant can read another's mental thoughts and transmit his own in return. It works on all beings within 25 feet of the mutant.

**REPULSION FIELD GENERATION:** The creature can create a force shield up to 50' away to surround or

trap other beings in an energy bubble. The repulsion field can take 5d6 points of damage before failing. This power can be used once per day.

**ILLUSION GENERATION:** The creature can create realistic illusions in the minds of other creatures within 100 feet. Only touch will convince the affected individual of the image's false nature. The illusion includes odor and sound appropriate for the vision observed by the affected creature.

**TELEKENISIS:** The creature can lift objects other than itself and move them about. He can use this power for up to five melee rounds before needing to rest for five rounds. The creature can lift any weight he himself could physically lift and move around. If this power is used against another individual or an object in another's possession, the creature must succeed in a mental attack against that individual.

The thief beasts lair in one of the apartments nearby and keep their plundered goods here. They have 6 brown color bands, 3 white color bands, a paralysis rod, a dozen hydrogen cells, two infrared goggles, an ecology life analyzer hand unit, two duralloy shields, and a security tracer unit stored there.

### AREA 4-2—ARBORETUM:

---

**The great boles of trees fill this space, brightly lit by artificial sunlight. The branches of the mighty trees form a green canopy overhead and the air is filled with birdsong. All appears placid and serene.**

An artificial forest designed to please the senses, this arboretum is an eyesore to the Hun wolfoids. They dream of claiming this area for their own and transforming the arboretum into more meadowlands to feed their horses and increase their numbers. The current residents of the arboretum have so far kept the Hun wolfoids from claiming the forest for their own. This place is home to a pack of sword bushes and a score of drain trees, making it a dangerous place to roam.

**Sword Bushes (10)** AC: 6, Hit Points: 30 each, Movement in Spaces: 10, Radiation Resistance: 5, Constitution: 5, Mental Resistance: 18, Strength: 5, Dexterity: 5

**Appearance:** This large fern-like plant possesses metallic fronds capable of slashing enemies. A jawed pod protrudes from the center of the plant and numerous dexterous vines extend from amongst the fern leaves.

**Normal Reaction and Attacking:** The sword bushes prowl this area, feeding on anything that wanders within reach. When pickings are poor, they utilize their *tel-*

# ATTILA ARMS APARTMENTS

## Level 4: Lido Level

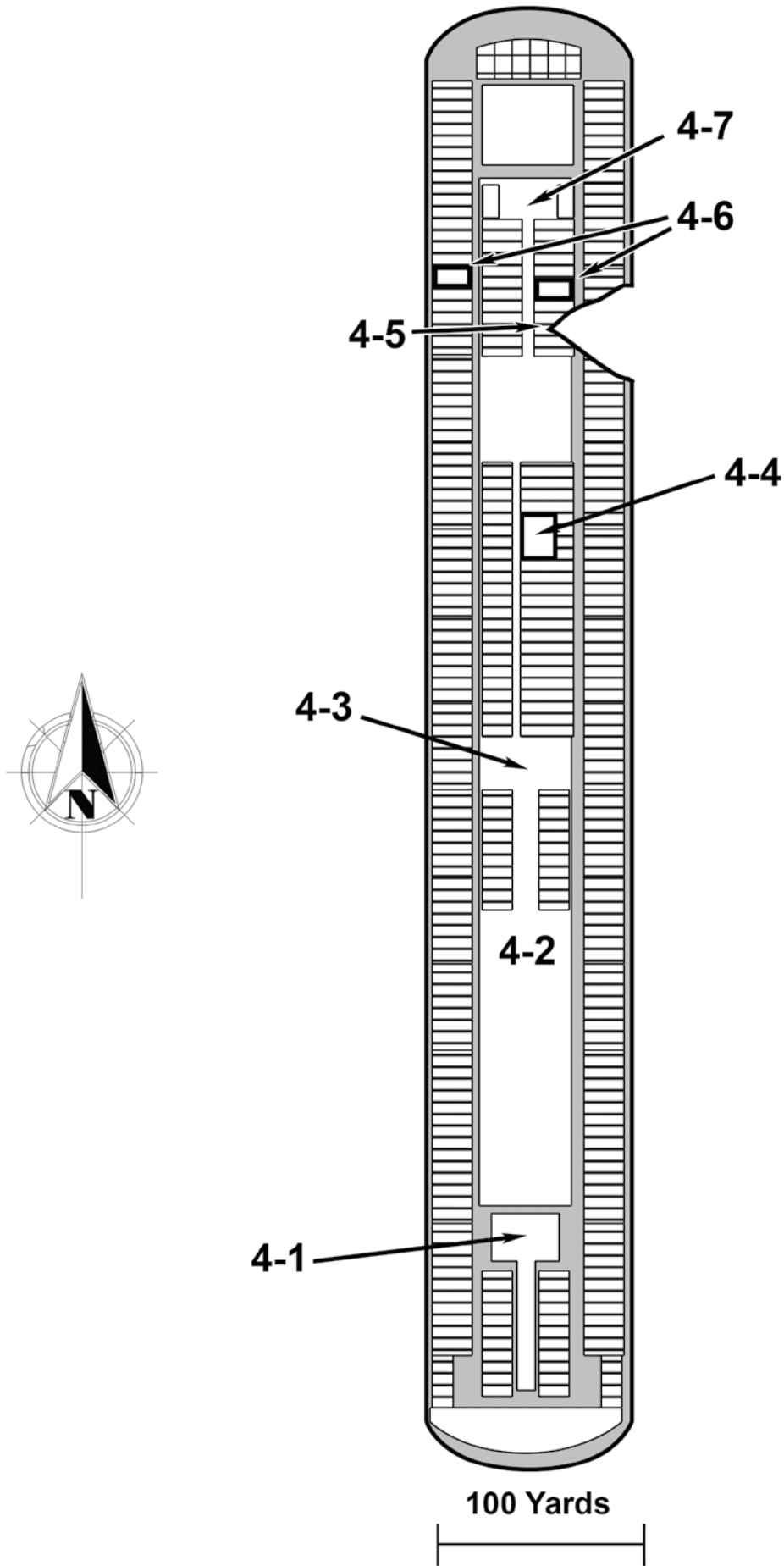

*eportation* power to hunt outside the apartment building, returning here when satiated. The jawed plant's *precognition* power and life detectors allow them to locate and predict the actions of any creature and they typically position themselves in a place where they can attack their prey with an advantage. A common tactic is to mentally dominate one creature and use it as a lure to bring its companions into range of its attacks. The sword bush then attacks with its leaves and jawed pod.

### Mutations or Defects

**LIGHT DEPENDENCY:** Sword plants become dormant during the night or when exposed to full darkness. They cannot move, use mutations, or attack while in this state.

**MANIPULATION VINES:** The plant has low-strength vines which it can use to move about and utilize artifacts.

**JAWED PLANT POD:** The plant has a 5' long, jawed pod similar to that of a Venus fly-trap to grab prey. The pod produces acid that eats away at victims, inflicting 20 points of damage each melee round.

**TELEPORTATION:** The plant can teleport to a location up to 3 miles away once per day. It must have seen the location personally within the last two years.

**PRECOGNITION:** The plant can see up to 3 minutes into the future. It can perform no other action during the round it uses this mutation.

**FORCE FIELD GENERATION:** The plant can create a wall of force that absorbs up to 5 dice of damage before failing. This power can be used once per day.

**MENTAL CONTROL:** With a successful mental attack, the plant can take control of an intelligent creature for 1 hour, utterly manipulating its actions.

**METALLIC LEAVES:** The plant possesses 18 large metallic leaves capable of stabbing and slashing its prey. If the plant is doing nothing else it can make 3 attacks on any nearby foe. The leaves are WC 3 and inflict 1d8/1d6/1d12 damage each.

**LIFE ENERGY DETECTORS:** The plant automatically detects living creatures of all types within 50' of it.

**Drain Trees (20)** - AC: 8, Hit Points: 100, Movement in Spaces: 0, Radiation Resistance: 18, Constitution: 18, Mental Resistance: 18, Strength: 3, Dexterity: 0

**Appearance:** These mutant maple trees have yellow-green leaves that appear to glow softly in dim lighting. They stand 40' tall, brushing the ceiling with their leaves.

**Normal Reaction and Attacking:** Drain trees have adapted to feed not only on sunlight, but myriad other forms of energy. Each tree absorbs various energy fields, negating their effects while within 50' of the plant. They have no direct attack, but other predators have learned that prey is often at a disadvantage in places where drain trees grow and hunt nearby.

### Mutations or Defects:

**ENERGY CANCELING:** The drain tree negates heat, sonic, and radiation energy within 50' of it. It also impedes mutant energy of this type, negating powers such as *radiation eyes*, *sonic abilities*, and *heat generation*. While in the area of effect, these mutations and any weapon producing the affected energy source simply do not function. This mutation ends if the drain tree is killed.

The sword bushes and drain trees have little need or desire for wealth or artifacts, but there are a handful scattered about the arboretum, relics left behind by intruders slain by the sword bushes. A careful search of the area turns up the following treasures: infrared goggles, a laser pistol with three shots remaining, a red color band, three brown color bands, a chemical flammable retardant, and a float pod.

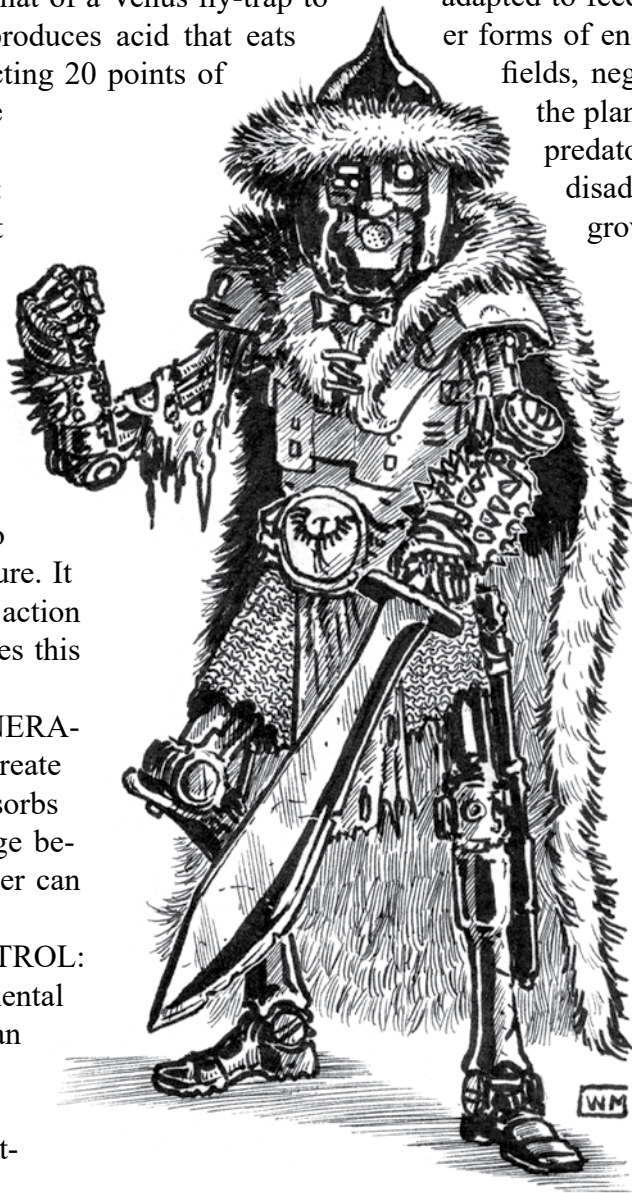

## AREA 4-3—CENTRAL ELEVATORS:

---

**Four metal doors flank the corridor here, two doors on either side. A wide stair/inclined plane arrangement stands to the south, providing access to the building's other levels. The floor here is covered with a viscous liquid that glows bright purple. A ruptured canister lies in the midst of the glowing sludge.**

An accident with a radioactive material container has contaminated this area with Intensity 14 radiation. Travelers using the stairs or elevators to reach this level find themselves stepping into the midst of the harmful substance without warning unless they possess Geiger counters or mutations capable of detecting the material.

## AREA 4-4—HUN BOT:

---

**A humanoid robot dressed in leathers and furs confronts you. It holds a sword in one hand; a short bow and quiver hang from its back. The bot's face is painted in savage patterns with oil and hydraulic fluid. It emits an electronic growl from its speaker plate, gesturing fiercely at you as if to intimidate you into leaving.**

The robot is AT-1LA, a former butler bot that accidentally downloaded the building's historical reenactment software and is now convinced it is a Hun warrior of old. AT-1LA attempted to join his wolfoid "brethren," but they attacked it, seeking to destroy the bot with their customary prejudice against artificial life. It now dwells in this area, venturing out to impose a one-robot horde on this level of the building.

**AT-1LA, Hun Bot (formerly a butler bot) - AC: 4, Hit Points: 50, Movement in Spaces: 75, Radiation Resistance: 3, Constitution: 3, Mental Resistance: 10, Strength: 9, Dexterity: 15**

**Power System:** Broadcast Power

**Body Style:** Humanoid

**Motive System:** Legs

**Defensive Systems:** None

**Miscellaneous Systems:** Human Normal Sensor Package, Short Wave communication package, 1st & 2nd level computer package, human skills programming package, Hun historical recreational package.

**Weapon Systems:** None, but AT-1LA can wield

swords, compound bows, and lassoes with the proficiency of a Hun warrior. It possesses a sword, compound bow, and 40 arrows.

**Appearance:** AT-1LA is a 6' tall metal humanoid, clothed in Hun clothing it acquired from an empty apartment's replicator unit. It speaks with a savage electronic voice, but occasionally relapses into the calm male baritone of its original programming.

**Normal Reaction:** AT-1LA is a unit in conflict. On one hand, it desires acceptance of its new Hun lifestyle, while on the other, its original programming compels it to serve humanity. This means it can only attack in self-defense, but responds with great aggression. True humans taking the time to communicate with AT-1LA might be able to convince it that its best chance of living out its new programming is to join them and help drive the "false Huns" out of the building. AT-1LA also responds to any color band if presented one, following orders in a savage and surly, but loyal manner.

AT-1LA will attempt to drive off intruders from this area, which it has claimed as its territory. It seldom ventures north of here, having barely escaped a run in with the tangles that lair in that area.

## AREA 4-5—TANGLER INFESTATION:

---

**This area is exposed to the outside thanks to a massive hole blasted through the complex's outer wall. Metal and plastics are melted and twisted, and the floor is scorched and buckled. Down the corridors leading away from this space are several robot units, motionless and their metal skin scarred by blackish-blue striations.**

Several decades ago, a flying transport collided with the side of the apartment, blasting a hole into this area. The wolfoids cleared out the wreckage in hopes of moving into this region, but a more troublesome occupant prevented them from doing so. A school of tangles, mutant jellyfish adapted for an aerial existence, nest in these corridors and rooms. Due to their translucent appearance, they are difficult to see until it's too late.

**Tangles (100) - AC: 4, Hit Points: 35, Movement in Spaces: 10 flying, Radiation Resistance: 12, Constitution: 10, Mental Resistance: 18, Strength: 6, Dexterity: 8**

**Appearance:** These creatures are overlarge box jellyfish with medusae the size of grapefruits. Yard-long tentacles drift beneath their transparent box-shaped

domes as they fly slowly about seeking prey. Normally clear and colorless in appearance, they strobe iridescent colors of blue, green, and red when agitated and attacking.

**Normal Reaction and Attacking:** Tangles hunt in schools of 2d10 when motivated by hunger, but more often are ambush predators. They rely on their natural camouflage to hide them until something edible wanders into the range of their tentacles. Strong power sources, such as those possessed by robots and vehicles, agitate tangles, causing them to swarm the energy source and relentlessly attack it until driven off or it is drained of power.

**Mutations or Defects:**

**PHYSICAL TRANSPARENCY:** Tangles are invisible to the naked eye unless agitated, but can be seen by infrared vision.

**STINGING TENTACLES:** Each round the tangler attacks 1d4 times with its tentacles (WC 3, DMG 1d6 plus Strength 12 paralysis poison). Paralyzed victims cannot move for 2d6 hours.

**DISSOVING TENTACLE:** Each tangler has a hollow tentacle that injects a chemical that dissolves flesh and allows the creature to siphon the resulting sludge up like a straw. Tangles only use this tentacle on paralyzed victims, automatically hitting and doing 2d6 damage each turn.

**ENERGY DRAIN TENTACLE:** Tangles possess a pair of secondary tentacles that disrupt energy sources, draining them of power. These WC 3 tentacles drain 1 hour of power from any robot, powered vehicle, large battery, or similar energy source on a successful hit.

**IMMUNE TO MENTAL ATTACKS:** Tangles have tiny brains that simply cannot be targeted by any mental attack.

**SONIC-VULNERABLE:** The gelatinous nature of tangles makes them susceptible to sonic attacks. They suffer double damage from any sound-based attack.

There are 100 tangles in groups of 2d10 throughout this area. Explorers in this section of the apartment face a 2 in 6 chance of blundering into a tangler ambush each full turn they remain here.

The robots in this area are four standard general purpose robots and three engineering robots. The tangles prevent them from recharging, draining them whenever their batteries begin to recharge. If the tangler school is driven out or destroyed, each unit returns to full power and function in 12 hours.

These apartments are in a state of ruin and disrepair. Furnishings are overturned and gnawed-upon, holes are nibbled into the walls, floors, and ceilings, and ducts are exposed for easy access. The entire area is a paradise for the countless squeaks that dwell here.

PCs entering into this area will be attacked by a gang of 2d6 squeaks every 1d6 turns unless they leave an offering of food or intriguing gifts for the mutant rodents. Doing so appeases the squeaks enough that they are content to merely observe the explorers from countless hiding places throughout the region. The PCs feel innumerable eyes watching their every step as they explore the ruined and trash-ridden apartments, but find little of use or value here. Anything of value has already been collected by the squeaks and brought as tribute to their king in area 4-7 below.

If the PCs attempt to communicate with the squeaks, they respond based on the Leadership Potential of the PC(s) making the attempt. If one or more of the PCs rolls its Leadership Potential or less on 3d6, the squeaks agree to communicate and, if asked, will bring the party to meet their king.

Should the PCs make non-violent contact with the squeaks and then turn on the mutant rats, they will forever more be attacked on sight and no manner of gift can appease the squeaks' rage. The party has lost their only chance to make them helpful allies.

**Squeaks** - AC: 4, Hit Points: 20 each, Movement in Spaces: 6, Radiation Resistance: 18, Constitution: 8, Mental Resistance: 11, Strength: 4, Dexterity: 17

**Appearance:** Squeaks are mutated Norway rats that greatly resemble their original stock. Their fur coloration, however, is particolored and it's common to encounter squeaks with colorful zebra stripes, splotches, swirls, and other fancifully bright patterns to their fur. Their eyes glow green in low-light.

**Normal Reaction and Attacking:** Squeaks are cautious creatures, preferring to observe from the myriad ducts, pipes, vents, and shadows that fill the apartment complex. They only attack when their have an advantage or are defending their homes or king. Squeaks prefer to operate with stealth, stealing what they require to survive and bringing it into the safety of their warrens. Thanks to their *radar* mutation, every squeak knows the full layout of the apartment complex and is capable of finding a route anywhere within its environs.

### **Mutations or Defects:**

**HEAT GENERATION:** Squeaks can ignite their bodies, creating an aura of fire that causes them no harm. Any creature struck by a squeak suffers 3d6 damage. This attack is WC 3.

**PHYSICAL REFLECTION (HEAT):** Squeaks are immune to heat-based damage, reflecting it randomly away from them. Any creature attacking a Squeak with a heat attack must roll a 1d6. On a result of a 1, the attack reflects back, striking them instead.

**HEIGHTENED BALANCE:** These creatures maintain their balance in even the most precarious circumstances, allowing them to scale walls, cross narrow ledges, and climb ropes without ever losing their balance.

**RADAR:** Squeaks can emit a high-pitched cry and use it to “see” in the dark, navigate in unknown areas, and mentally map places. This power has a range of 100’.

### **AREA 4-7—SQUEAK KING’S COURT:**

**Trash, broken furniture, and other debris fill this space, making it impossible to determine its size and true contents. The area is dark with only a few of the lighting panels in the ceiling still functioning. Tiny pairs of glowing green eyes peer out at you from amongst the debris.**

The squeaks infest the entire complex, but this is the heart of their empire. It is here their king dwells and it is to him they bring tribute. This area is filled with 100 of the mutant rats watching the PCs intently from the

safety of the junk-filled chamber and connecting corridors. If the PCs are brought here by other squeaks, they are allowed to enter the heart of the section, a clearing amongst the debris where the king holds his court. Otherwise, they are viciously attacked as the squeaks defend their king and home.

**King Den, Squeak King** - AC: 1, Hit Points: 40, Movement in Spaces: 6, Radiation Resistance: 18, Constitution: 12, Mental Resistance: 15, Strength: 6, Dexterity: 17

**Appearance:** King Den is a larger than average Squeak with pink and green polka dotted fur and only a single eye. He speaks with a surprisingly low-pitched voice for such a small creature

**Normal Reaction and Attacking:** King Den expects to be treated as royalty and failing to do so quickly earns his ire. Those who demonstrate proper courtesies and conduct themselves in a manner befitting his court are treated as respected guests in turn. If insulted or directly attacked, King Den commands his numerous underlings to avenge his honor before scurrying away to safety.

### **Mutations or Defects:**

**HEIGHTENED DEXTERITY:** The creature has an AC 1 of when unencumbered.

**HEAT GENERATION:** Squeaks can ignite their bodies, creating an aura of fire that causes them no harm. Any creature struck by a Squeak suffers 3d6 damage. This attack is WC 3.

**PHYSICAL REFLECTION (HEAT):** Squeaks are immune to heat-based damage, reflecting it randomly



away from them. Any creature attacking a Squeak with a heat attack must roll a 1d6. On a result of a 1, the attack reflects back, striking them instead.

**HEIGHTENED BALANCE:** These creatures maintain their balance in even the most precarious circumstances, allowing them to scale walls, cross narrow ledges, and climb ropes without ever losing their balance.

**RADAR:** Squeaks can emit a high-pitched cry and use it to “see” in the dark, navigate in unknown areas, and mentally map places. This power has a range of 100’.

King Den can be made a useful friend if either: A) the PCs convince them to become their ally (resolve as if the party was attempting to make King Den a follower as per *MA* p. 10-11) or B) they express interest in driving out or slaying the Hun wolfoids. In either event, King Den proposes an alliance: the Squeaks will aid the PCs in return for a fair share of any plunder and that, when the dust settles, the Attila Arms Apartment complex is given to the Squeaks as their territory.

If the PCs politely refuse this offer, King Den allows them to depart unharmed, but suggests they consider his proposal and return when they see the wisdom in such an alliance. If the party mocks the King’s offer, their safety is forfeit and his followers extract revenge for the slight to their king.

This area contains all the plunder and tribute ever brought to King Den. If the Squeaks are somehow overcome and the PCs have free rein to plunder this area, the following can be found: countless brown color bands, 19 white color bands, 15 gray color bands, 12 green color bands, 7 red color bands, 2 ecology life analyzer hand units, 1 security hand unit, 4 security tracer units, 1 medical hand analyzer and healer, 1 sonic torch, 1 laser torch, 7 pairs of sound elimination head phones, 2 Geiger counters, 7 infrared goggles, 1 space suit, 8 portable energy lamps, 136 hydrogen cells, 4 paralysis rods, 3 paralysis dart ejectors, 100 uncharged paralysis darts, 1 paralysis dart charger, 1 laser pistol, 3 slug projectors, 300 rounds of slug projector ammunition, a sensory intensifier, and 500 tubes of universal food paste. There is also 437 domars, many of which are chewed-up.

## LEVEL 5: SKY FLOOR

### AREA 5-1—WEAPON PLATFORM:

---

**A circular wooden platform extends partially over the edge of the roof. A curious contraption the size of a modest boulder and made of steel, timber, and cords rests atop the stage. A barrel filled with what appears to be feathered bars stands nearby. Six wolfoids man the platform, scanning the skies warily.**

This squad of six Hun wolfoids are trained to operate this curious piece of primitive artillery. Three man the device, while the others act as lookout and guards. All are armed with swords and compound bows. They only use the artillery piece against non-flying enemies on the roof as a last resort for fear of injuring the pegasi in area 5-2.

The odd device is a hwacha, a crude form of early rocket launcher capable of firing up to 200 rocket-propelled arrows at a time. The Hun wolfoids have positioned it atop a turntable platform, giving them firing arcs around the entire apartment complex. In addition, the hwacha tilts and can be aimed at airborne targets overhead.

The hwacha is WC 5 and it has a range of 2000 yards. It is an area of effect weapon and all targets within a 50’ square area are subject to the weapon’s attack. The referee makes a single attack roll against all subjects and if the roll is successful, the subject is hit by 1d6+1 rocket arrows that inflict 3d6+3 damage each. Due to its intricacy, the hwacha is a Complexity 6 device. It requires a crew of three to operate and can fire a volley once every six rounds.

The barrel contains 400 arrows, each with a gunpowder rocket strapped to the shaft. If the barrel is set alight, all the arrows within explode, creating a 50’ diameter blast that destroys the weapons platform and inflicts 20d6 damage to all creatures in the area of effect.

### AREA 5-2—PEGASI MEADOW:

---

**A broad swath of green grass covers the rooftop. Grazing serenely on the meadow is a herd of white ponies. Each of the horses has a pair of feathery wings protruding from its back. A small, windowless building stands at the north end of the grassy field.**

# ATTILA ARMS APARTMENTS

(Hun Wolfoids)  
Level 5: Sky Floor

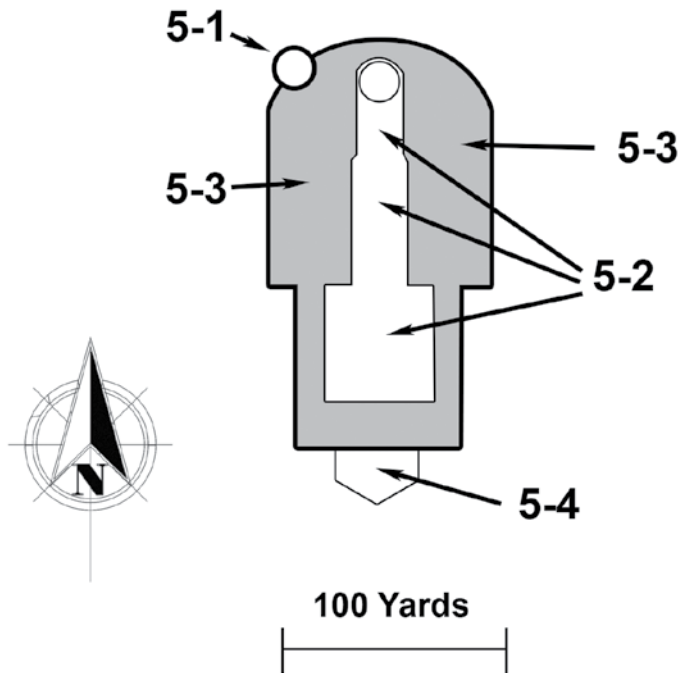



## AREA 5-4—WATERSLIDE RUINS:

---

The horses are a rare breed of pegasus possessing the *taller* mutation, making them a bigger strain than their smaller cousin. Due to their increased size, they can be ridden by man-sized creatures, a fact the Hun wolfoids use to great advantage. These mounts are owned by the elite Sky Riders of the tribe.

**Greater Pegasus (20)** - AC: 4, Hit Points: 60 each, Movement in Spaces: 9/18 flying, Radiation Resistance: 14, Constitution: 14, Mental Resistance: 16, Strength: 16, Dexterity: 13

**Appearance:** An ivory white mutant pony standing 4' tall at its withers. It possesses broad, feathery wings with a 15' wingspan. Other than coloration and wings, the mutant pony resembles its unchanged Earthly counterpart.

**Normal Reaction and Attacking:** Pegasi are extremely suspicious of any unfamiliar non-wolfoid approaching them and will warn the intruder away with loud snorts and flapping wings. Only their riders are allowed to come into contact with them. Any who persist in interfering with the creature is 33% likely to be attacked by the pegasus. If the mutant pony doesn't attack, it flies off and stays away until the intruders leave. Pegasi attack twice per round with their hooves (WC 3; dmg 1d8+2/1d8/1d12)

### **Mutations or Defects**

**THICK HIDE:** The creature has dense skin that resists attacks like armor. This results in an increased AC and non-powered physical attacks inflict half damage.

**WINGS:** Pegasi can fly at a rate of 18 yards per round and carry up to 300 lbs.

The building is locked and requires a gray or red color band to open. Inside are thirty curious saddles, bits, and bridles, all tack for the pegasi herd. Figuring out how to dress the flying ponies with this equipment properly is a Complexity 9 task and only possible if the pegasus acquiesces to being ridden. There are also 10 spare Hun compound bows and 200 arrows in special quivers designed to be strapped to the pegasi saddles.

## AREA 5-3—WATERING HOLES:

---

**An artificial pool filled with clear water is set into the rooftop at this position. Muddy hoof prints around the pond show that, whatever purpose it once served, it is now used as a watering hole.**

These spaces were once spas, but the hot tubs are now watering troughs for the pegasi in area 5-2. The pools are 4' deep and regularly refilled with clean water by the Hun wolfoids. There is nothing of interest or value here.

**Broken struts, severed posts, and shattered pipes litter this area. Most of the damaged pieces show signs of being physically attacked and burned. The debris forms an uneven mound measuring 10' high and spread across a 50-yard area.**

The Hun wolfoids destroyed the waterslide so that the pegasi herd would have an unobstructed flight path to and from the grassy meadow and the hwacha would have a clear field of fire. They've left the debris untouched since then. Recently, a clutch of winged biters has taken up residency in the debris.

**Winged Biters (4)** - AC: 4, Hit Points: 25 each, Movement in Spaces: 5/12 flying, Radiation Resistance: 18, Constitution: 8, Mental Resistance: 17, Strength: 10, Dexterity: 18

**Appearance:** Winged biters are 6' long reticulated pythons possessing feathered wings measuring 4' across. They can shift their coloration to camouflage itself in its natural surroundings.

### **Mutations or Defects**

**CAMELEON POWERS:** The creature is nearly impossible to see when camouflaged.

**Normal Reaction & Attacking:** Winged biters are extremely territorial and it's very easy for others to blunder into their territory unaware of their presence. The snake always attempts to warn away intruders, hissing fiercely. If this has no effect, it spits Strength 13 poison every other round. In dire straits, it can attack with a bite (WC 2, dmg 1d6/1d6/1d6).

Hidden within the debris are the rotting remains of a mutant humanoid. It wears plastic armor (AC 3) and has a jumper exoskeleton still strapped to its decaying form. There is enough power in the exoskeleton for it to operate for 7 more hours before the atomic cells need replacing.

# A87 THE HOTEL WARDEN

BY JAMIES M. WARD

## INTRODUCTION

The Hotel Warden is the tallest building in Epsilon City. Over the three hundred years since the cataclysm it has suffered through several military actions that have turned a few floors to rubble. During these centuries mutated plants and fungus have been allowed to grow and fill several levels of the hotel.

A separate A.I. intelligence runs the hotel. After 300 years of operation the A.I. is quite insane and not doing its proper job of fixing things that go wrong and allowing pure humans to live in its chambers. Anyone who successfully fixes this A.I. will soon discover that they have caused worse problems as it takes extreme measures to restore the levels to the state they belong in as well as starting to charge rent to those who live on the various levels.

Each floor is based on the exact same layout: four apartments and a large middle hall between the, with a central elevator that can go from the top to the bottom of the hotel. On the north outside of the building is a freight elevator that extends from the top to the bottom. On the south outside of the building is a duralloy fire escape that has an opening on every level.

On the map, A, B, C, and D are identical apartments unless some being is living there now. E is the fire escape easily able to hold the weight of any size creature. F is a freight elevator on the outside of the building and able to bring up very large objects. G is the central apartment elevator.

The apartments are very similar, but individual residents could change the layout of the apartments. There are usually three bedrooms with one twice the size of the other two. There is a kitchenette and dining area with a replicator that can make over a thousand different meals. There is a living room with a large screen TV that has three hundreds years of shows to broadcast. There is a large storage pantry. There is a large bathroom with a huge shower, a Jacuzzi for 10, a toilet and a urinal.

## WHY WOULD CHARACTERS COME TO THIS PLACE?

The Hotel Warden is the largest building in the city and the view from most of the levels is stunning and allows for an excellent look at the city.

It is easy to reach from a lot of areas. There is the main and obvious front door. The freight elevator is obvious, but requires a band just like the central elevator in the middle of the building. The fire escape is easy to use and the doors at every level are considered emergency doors and easy to open by hand.

There is no way to get lost as the characters adventure through the building. They always know what level they are on.



Early on they will notice there is a lot of equipment in the hotel that is useful to adventurers. In fact, there is a lot of destroyed equipment (perhaps including a little salvageable material) that lies at the foot of the hotel, discarded by the inhabitants of the structure from the balconies and widows above. In addition, the mutant birds residing near the top of the structure discard the remains of their prey by heaving them onto the lawn below. This means a large number of skeletal and torn apart corpses rot nearby. Twenty brown bands, 2 red bands, and 3 white bands to be found in the rubble around the building, formerly worn by their unfortunate meals.

## BASEMENT

As you come into this area you notice an odd stale smell to the level. You see many types of robots in the corridors. A voice sternly advises you that you shouldn't be in this area.

"Your kind is not allowed here. Go to the check-in desk on level one and they will take care of your needs."



If the characters ignore the crazed A.I., it shouts louder and louder that the characters should leave the level all together, becoming increasingly agitated and threatening. Eventually it activates its security robots to eject or neutralize them.

## ROBOTIC SYSTEMS PROCEDURES

A basic non-combat robot type is selected by the hotel A.I. to respond to an encounter or an event (such as a fire or loud noises), based on its somewhat distorted idea of the situation. If that robot is stopped, damaged, or destroyed, a security robot is sent into the situation. If that robot is damaged or destroyed two and then four security robots are sent to fix the situation. Eventually (one the danger passes) engineering robots take the broken robots to the basement to be repaired.

**North section** – There is a wall with a secret panel that opens from the action of an engineering color band. Behind the wall is the A.I.'s machinery and mainframe. The A.I. currently runs the robots and devices of the apartments. If the A.I. is fixed all of the robots come out of hiding and begin extreme and ruthless repairs that have deadly effects on the flora and fauna of the hotel levels.

**Middle & South section** – There are ten each of the various robots. If any of these units gets damaged or destroyed they are fixed or replaced in the repair module on the west side of the basement. The middle section also has the central hotel elevator. The basement level cannot be accessed without the use of an engineering band.

**Security Robot (10)** - AC:5 Hit Points: 50, Movement in Spaces: 75 flying, Radiation Resistance: 9, Constitution: 9, Mental Resistance: 9, Strength: 9, Dexterity: 15

**Power System:** 72-hour battery pack

**Body Style:** Oval Shell

**Motive System:** Anti-grav Floating Pod

**Defensive Systems:** 100-point energy shields with thick armor plating

**Miscellaneous Systems:** Human normal sensor package, Short wave radio communication package. 1st & 2nd level computer package, human skills programming package.

**Weapon Systems:** 4 paralysis tentacles extending 13 feet, gas pellet ejector shooting with 11 intensity poison knock out gas; 2 third-stage slug projectors (2d6

# WARDEN, SILVER HOTEL

## Standard Level

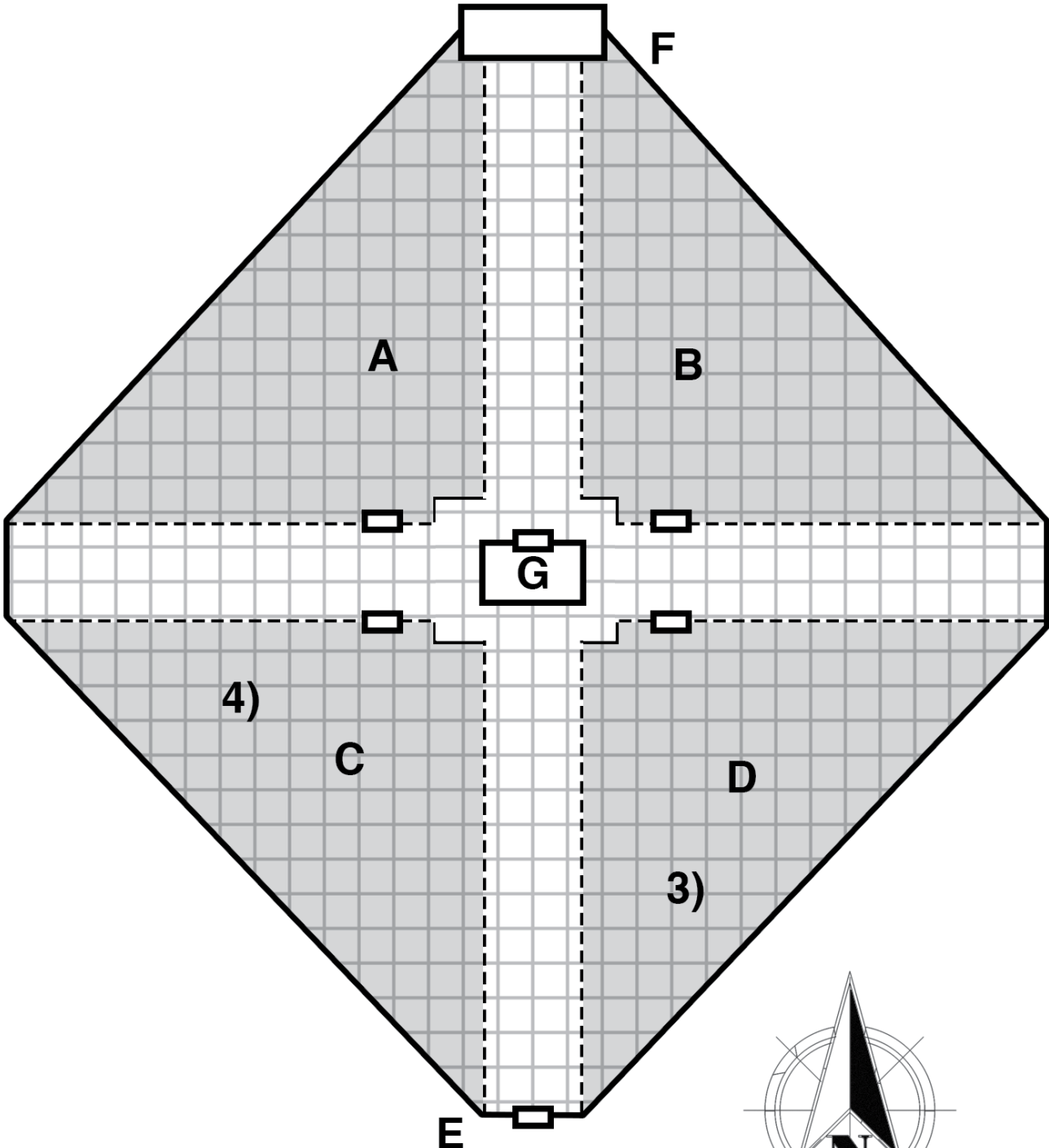

of subdue damage, 3 padded control tentacles, all at Weapon Class 4).

**Active Systems:** 2 long-range visual receptors (6 miles), sound receptors (range 295 feet), 72-hour battery pack, anti-grav propulsion, two way radio circuit, and command and control systems for the takeover of other mechanical systems.

**Appearance:** Security robots always have an egg shaped body and float in the air, and is six feet tall. Its surface is shiny and usually featureless unless one of the tentacles is extended for use.

**Normal Reactions and Attacking:** These robots are programmed to preferentially neutralize and subdue. They seek to paralyze a victim and take them to the nearest security center.

**Mark III Military Kill Robot (10)** - AC: 5, Hit Points: 60, Movement in Spaces: 100, Radiation Resistance: 18, Constitution: 18, Mental Resistance: 18, Strength: 18, Dexterity: 18

**Power System:** Broadcast energy and fusion battery

**Body Style:** Humanoid Form

**Motive System:** Two legs

**Defensive Systems:** Heightened armor system

**Miscellaneous Systems:** Military attack programs, human sensory package, horticultural pruning shears, weed killer sprayers, glass cleaning sprayer, trash bin.

**Weapon Systems:** Laser system 6d6 (weapon class 6, IC 3); plasma canon 10d6, Weapon Class of 7, IC 8), 6 mini-missile pack 50 damage points per missile (Weapon Class 4, IC 5).

**Appearance:** The humanoid robot is ten feet tall with a missile package on his shoulder and weapons systems along his arms. Its head has the use of human senses. Sparks are constantly flying from its body as it moves.

**Normal Reaction and Attacking:** The robot is sent out to destroy dangerous beings. As it does its work it often grabs technology it notes on its foes and makes that technology its own. These units are under the control of the hotel A.I. and would never attack the hotel or its customers.

**Specialized Engineering Robot (10)** - AC: 2, Hit Points: 75 Movement in Spaces: 25, Radiation Resistance: 10, Constitution: 10, Mental Resistance: 10, Strength:10, Dexterity:10

**Miscellaneous Systems:** Computer diagnostic system, Engineering programs with appendages to match, three light systems, short wave radio systems, human senses programs, arc welding systems, mock up tools, fusion energy plant, anti-grav motive system. There are spare part electronic boards and other replacement

devices stored in a rear compartment of the bot.

**Appearance:** This unit is a large rectangular shaped device ten feet long, three feet tall and wide and floating on an anti-grav pad.

**Normal Reactions and Attacking:** The unit is designed to fix anything in the hotel. Drafting diagrams are in the memory of the bot. Schematics on every device originally in the hotel are in the memory banks of the unit. If attacked the unit retreats to the basement to be repaired. The unit can do 15 points of damage to robotic devices, but can't harm any other type of being.

**Butler Robot (10)** - AC: 4, Hit Points: 50, Movement in Spaces: 75, Radiation Resistance: 3, Constitution: 3, Mental Resistance: 10, Strength: 8, Dexterity: 15

**Power System:** 48-hour power pack

**Body Style:** Humanoid

**Motive System:** Legs

**Miscellaneous Systems:** Human normal sensor package, short wave communication package, 1st & 2nd level computer packages, human skills programming package.

**Appearance:** The robot is six feet tall with a humanoid shape. It has a square head with large visual lenses. The unit's hands are articulated and can manipulate things like a human hand can.

**Normal Reaction:** The unit deals with pure humanoids best. However, it is able to deal with any intelligent being after getting used to the fact that the being can communicate.

## EAST SECTION OF THE BASEMENT

This area is mainly filled with a fusion energy plant that powers the entire hotel.

## WEST SECTION OF THE BASEMENT

In this area is a specialized engineering repair unit with replicator technology. Broken things placed in this area have the device repair the unit or replace it with a new unit.

## **ELEVATOR & FREIGHT ELEVATOR ENCOUNTERS**

Each time the elevator or freight elevator door opens for the characters, roll a d6. On a six there is something in the elevator or waiting for the elevator as it opens. Roll on the random encounter chart to determine what that encounter will be.

If the characters let the elevator close, it is empty when it comes back to that level.

## FREIGHT ELEVATOR

At the ground floor this elevator is visible on the outside of the hotel. It can be opened with any color band. The chamber is large at 15 yards deep, 30 yards wide and 15 yards tall. There are patched blast marks on several of the walls. This makes it obvious that there were several different types of battles in and around this freight elevator. The elevator clearly has cables allowing it to go to the 50th story of the hotel.

When the doors open roll a d6 and on a 6 there is a random encounter, as with the freight elevator, above.

## INSIDE THE ELEVATOR

Any color band will open this elevator. The doors are shiny stainless steel. The elevator is cleaned and repaired every day. The inside walls are stainless steel. The elevator is a 10-yard cube.

## RANDOM ENCOUNTER TABLE: THE WARDEN HOTEL (ROLL 2D6):

**2 – Friendly Security Robot** AC: 5, Hit Points: 50, Movement in Spaces: 75 flying, Radiation Resistance: 9, Constitution: 9, Mental Resistance: 9, Strength: 9, Dexterity: 15

**Power System:** 72-hour battery pack

**Body Style:** Oval Shell

**Motive System:** Anti-grav Floating Pod

**Defensive Systems:** 100-point energy shields with thick armor plating

**Miscellaneous Systems:** Human Normal Sensor Package, Short Wave communication package. 1st & 2nd level computer package, human skills programming package.

**Weapon Systems:** 4 paralysis tentacles extending 13 feet, gas pellet ejector shooting with 11 intensity poison knock out gas; 2 third-stage slug projectors (2d6 of subdue damage, 3 padded control tentacles, all at Weapon Class 4).

**Active Systems:** 2 long-range visual receptors (6 miles), sound receptors (range 295 feet), 72-hour battery pack, anti-grav propulsion, two way radio circuit, and command and control systems for the takeover of other mechanical systems.

**Appearance:** Security robots always have an egg shaped body, six feet tall. Its surface is shiny and usually featureless unless one of the tentacles is extended for use.

**Normal Reactions:** This robot will help the characters if they remain calm. It talks to them about the hotel

and wants to know why they are there. If they don't have a room, the robot is forced to escort them out of the hotel.

**3 – Tiny Mushroom Men (10)** - AC: 7, Hit Points: 7 each, Movement in Spaces: 2, Radiation Resistance: 18, Constitution: 9, Mental Resistance: 18, Strength: 3, Dexterity: 18

**Appearance:** Each mushroom man is two inches tall and carrying a three inch spear.

**Normal Reactions and Attacking:** These little guys are aggressive. They have no misgivings about attacking player characters. Rubbery and spongy, they are able to bounce huge distances. If they bounce into the naked chest of a character they are absorbed into that chest and vanish. 7 days later 10 mushroom men appear from the character's chest. The character loses 2 hit points per new mushroom men. If the mushroom men are routed they call on their larger brothers with high-pitched shrieks and in a few hours new and larger mushroom men appear to avenge them. The spear has a weapon class of 2 and does 1 point of damage per strike.

### Mutations or Defects:

TELEPATHY, HEIGHTENED PRECISION, MENTAL BLAST, PYROKINESIS, REPRODUCTION



**4 – Middle Sized Mushroom Men (5)** - AC: 4, Hit Points: 25 each, Movement in Spaces: 6, Radiation Resistance: 18, Constitution: 11, Mental Resistance: 18, Strength: 7, Dexterity: 18

**Appearance:** Each middle sized mushroom men stands six feet tall. It holds a 9 feet long spear.

**Normal Reactions and Attacking:** These are aggressive and fearless. They don't usually appear unless their little cousins summon them. They have no problem fighting to the death. They communicate with others and aren't interested in anything but occupying and defending damp and dark areas, such as where other fungi grow. They need that type of environment to grow and thrive.

**Mutations or Defects:**

TELEPATHY, HEIGHTENED PRECISION, MENTAL BLAST, PYROKINESIS, REPRODUCTION, TALLER

**5 – Jawed Plant (3)** - AC: 5, Hit Points: 30, Movement in Spaces: 2, Radiation Resistance: 11, Constitution: 11, Mental Resistance: 11, Strength: 11, Dexterity: 11

**Appearance:** This green leafy plant stands ten feet tall. It is a 9 feet long jawed head that is able to move up to 20 feet away from the plant. There is a large mass of thick tentacles around the plant and it can move with these and grasp things as each tentacle is very muscular and can move rapidly.

**Normal Reactions and Attacking:** The carnivorous plant is constantly hungry. It tries to grab food whole with its jaw (Weapon Class 2, jaw bites for 10 points of damage, and then acid does 3d6 points per combat turn as long as the victim is in the jaw). The tentacles are used to wrap possible victims (Weapon Class 2, each tentacle squeezes for 2 points of damage and the plant can use up to three tentacles on each victim).

**Mutations or Defects:**

TALLER, NEW BODY PART, HUMAN SENSES, LEVITATION, TENTACLES

**6 – Pacu Pacu (4)** - AC: 3, Hit Points: 19 each, Movement in Spaces: 12, Radiation Resistance: 18, Constitution: 18, Mental Resistance: 18 Strength: 3, Dexterity: 18

**Appearance:** These are head sized cubes of fur. There is never a duplicate in the color of fur for all Pacu.

**Normal Reactions:** They move about by bouncing. As their fur touches living flesh there is a 52% chance

the flesh stiffens. The stiffening slows the character to three quarters speed. The affect takes several weeks to wear off. The affect is cumulative with multiple touches. The Pacu love radiation and search everywhere for stronger and stronger intensities. They can absorb radiation only by absorbing sufficient radiation can they reproduce their kind.

**Mutations or Defects:**

ABSORPTION (Lasers), MENTAL PARALYSIS, MENTAL TRANSPARENCY, REGENERATION

**7 – Butler Robot** - AC: 4, Hit Points: 50, Movement in Spaces: 75, Radiation Resistance: 3, Constitution: 3, Mental Resistance: 10, Strength: 8, Dexterity: 15

**Power System:** 48-hour power pack

**Body Style:** Humanoid

**Motive System:** Legs

**Miscellaneous Systems:** Human normal sensor package, short wave communication package, 1st & 2nd level computer packages, human skills programming package.

**Appearance:** The robot is six feet tall with a humanoid shape. It has a square head with large visual lenses. The unit's hands are articulated and can manipulate things like a human hand can.

**Normal Reaction and Attacking:** The unit deals with pure humanoids best. However, it is able to deal with any intelligent being after getting used to the fact that the being can communicate. This robot is taking down a bundle of type three slug throwers in a basket. If treated respectfully it gives the rifles to the characters (Weapon Class 5, 4d6 on damage, IC 3).

**8 – Robotic Mass** - AC: 8, Hit Points: 50, Movement in Spaces: 20 Radiation Resistance: 3, Constitution: 3, Mental Resistance: 3, Strength: 3, Dexterity: 3

**Power System:** 48-hour power pack

**Body Style:** Mass of equipment

**Motive System:** Small rubber Wheels

**Miscellaneous Systems:** Human normal sensor package, short wave communication package, 1st & 2nd level computer packages, human skills programming package.

**Appearance:** The robot appears to be a mass of loose equipment resting on the floor. There are gears, fan belts, crystals, and circuit boards all exposed to the air.

**Normal Reaction:** The unit has its own agenda and wants to be left alone. Touching or striking the unit causes an arc of lightning to strike back (Weapon Class 8, 25 points of damage, IC 4).

## 9 – Radiation Cloud

A cloud of green gas is suspended in the middle of the elevator. The gas is infused with intensity 14 radiation. The cloud won't move unless touched and then it engulfs the being touching it. The cloud will be gone when the elevator doors open a second time.



**10 -- Pirate wolfoid (4)** - AC:8, Hit Points:69, 66, 64, 61, Movement in Spaces:12, Radiation Resistance:18, Constitution:14, Mental Resistance:12, Strength:16, Dexterity:18

**Appearance:** Descended from the timber wolf, this mutation stands nine feet tall on its

humanoid hind legs. It wears historical and colorful pirate garb. Armed with a large cutlass and several types of black powder weapons, this creature can be very dangerous. It is highly intelligent and well able to use the technology of the ship. Its front paws have mutated into grasping hands with long, razor sharp talons.

**Normal Reactions and Attacking:** Other Wolfoid groups tend to stay away from this class of creature. Its cutlass is Weapon Class 3, inflicting 1d12 +4 points of damage. Its various black powder guns are Weapon Class 5 doing 20 points a strike. These creatures will attempt to capture female opponents rather than killing them.

### **Mutations or Defects:**

**MANIPULATIVE PAWS** – allows the mutant to handle any human built device.

**REFLECTIVE FUR** – Reflects all types of energy.

**CONTACT POISON RESISTANT** – Its fur resists all the affects of contact poison.

**REGENERATION** – This mutant regenerates 5 lost hit points per melee round.

**RADIATED EYES** – 14 intensity useable once per day

**11 -- Roman wolfoid (6)** - AC4, Hit Points:79, 76, 74, 71, 70, 66, Movement in Spaces: 10, Radiation Resistance:12, Constitution:15, Mental Resistance:12, Strength:12, Dexterity17

**Appearance:** These wear a garb typical of a Roman le-

gionnaire. Their red cloaks grant a plus to the armor class.

**Normal Reactions and Attacking:** A typical legionnaire throws a javelin (Weapon Class 4, inflicting 1d10+4 in damage). It has a spear for a first strike in melee combat (Weapon Class 2, inflicting 1d12 +4). It is capable of pulling its gladius (shortsword) (Weapon Class 2, strikes twice in a combat round, inflicting 1d10+4 in combat per strike).

These wolfoids will never attack anything that looks like a dog, wolf, or bear. They will retreat from such battles. The trick of attacking twice in a combat round with a gladius can be learned by characters after they use the weapon twice in combat.

### **Mutations or Defects:**

**REFLECTIVE FUR** – Fur resists laser and other energy attacks

**FIRE VULNERABILITY** – Fire attacks do double damage to these wolfoids

**TELEPATHY** – These wolfoids have telepathy with a 150-yard range

## **12 – Egyptian Wolfoid (6)**

AC:3, Hit Points:77, 75, 71, 66, 61, 60, Movement in Spaces:12, Radiation Resistance:18, Constitution:17, Mental Resistance:16 Strength:15, Dexterity:14

**Appearance:** These nine-foot tall wolfoids have red ophidian flesh instead of fur on their bodies. They are dressed in ancient Egyptian leathers and their helmets look like the hood of a cobra. They are often seen riding on two wheeled chariots pulled by android horses.

**Normal Reactions and Attacking:** They use a special long bow in battle: as one wolfoid fires the bow, the other drives the chariot (Weapon class 1, inflicts 1d10 +4 points of damage). For melee they use a large shield (+1 bonus on armor class) and a long spear (Weapon class 2, inflicts 10 points of damage).

These wolfoids won't attack anything that remotely looks like a snake or reptile of any type. They love riding some distance away from foes and making long range attacks with their bows. The bow has a strong pull and can only be used by beings with a Strength of 16 or more.

### **Mutations or Defects:**

**REFLECTIVE FUR** – Their scales have kinetic absorption and stop the first 5 points of every kinetic attack.

**LIGHT ABSORPTION** – Light absorption allows the mutant to gain 6 points of healing from every laser attack and be completely invulnerable to lasers or any light attacks



## LEVEL ONE – MANAGERIAL AND ADMINISTRATION LEVEL

There is a large set of double doors leading to the street outside the hotel. When characters come through the front door, the first thing they see is the front desk.

**Coming into the hotel, you see two robots at a large desk. They motion you to come toward them. They speak to you, “The Epsilon Hotel welcomes you and hopes you will have a relaxing stay. How many of you will be staying with us today? Also, how long will you be staying at the hotel?”**

The robots will expect some type of down payment in domars. Any amount of the coins will do. Rooms on the second and third floor can be given to the characters.

**North Section** – This is the front desk and office area for the hotel. There is a butler working the front desk. It will look for a human shaped customer and then it can assign a set of apartments to the character as long as that customer has 10 domars.

- The section has a large front desk with two computer terminals. The office behind the desk is equipped with three workstations. There is a washroom with a bath in this office section.
- The robot is happy to talk about the levels and tells the group what they want to know about the condition of the hotel. The unit keeps asking if the group wants to rent rooms for the day.

Doing anything materially destructive on the floors still maintained by the A.I. will draw the attention of a security robot to the level to kick the group out of the hotel.

**Butler Robot** - AC:4, Hit Points:50, Movement in Spaces:75, Radiation Resistance:3, Constitution:3, Mental Resistance:10, Strength:8, Dexterity:15

**Power System:** 48-hour power pack

**Body Style:** Humanoid

**Motive System:** Legs

**Miscellaneous Systems:** Human normal sensor package, short wave communication package, 1st & 2nd level computer packages, human skills programming package.

**Appearance:** The robot is six feet tall with a humanoid shape. It has a square head with large visual lenses.

The unit's hands are articulated and can manipulate things like a human hand can.

**Normal Reaction:** The unit deals with pure humanoids best. However, it is able to deal with any intelligent being after getting used to the fact that the being can communicate.

---

### WEST SECTION

This is a storage area for suitcases, extra parts for devices on the level, and a vault filled with jewelry. All of the normal apartment features have been removed. There is still a large bathroom in this section. In the corner of this area is a white pile of ash. Hidden in that ash are four brown bands and two green ones.

The area has two jail cells in case temporary jailing is needed. There are two skeletons in the right cell as those people starved to death two hundred years ago.

---

### SOUTH SECTION

This is a set of four business offices. There are two butler robots in this area. They are very careful in not allowing characters into this area to do damage. If the characters ignore the robots two security robots are summoned.

**Butler Robot (2)** - AC: 4, Hit Points: 50, Movement in Spaces: 75, Radiation Resistance: 3, Constitution: 3, Mental Resistance: 10 Strength: 8, Dexterity: 15

**Power System:** 48-hour power pack

**Body Style:** Humanoid

**Motive System:** Legs

**Miscellaneous Systems:** Human normal sensor package, short wave communication package, 1st & 2nd level computer packages, human skills programming package.

**Appearance:** The robot is six feet tall with a humanoid shape. It has a square head with large visual lenses. The unit's hands are articulated and can manipulate things like a human hand can.

**Normal Reaction:** The unit deals with pure humanoids best. However, it is able to deal with any intelligent being after getting used to the fact that the being can communicate.

**Security Robot (2)** - AC: 5, Hit Points: 50, Movement in Spaces: 75 flying, Radiation Resistance: 9, Constitution: 9, Mental Resistance: 9, Strength: 9, Dexterity: 15

**Power System:** 72-hour battery pack

**Body Style:** Oval Shell

**Motive System:** Anti-grav Floating Pod

**Defensive Systems:** 100-point energy shields with thick armor plating

**Miscellaneous Systems:** Human Normal Sensor Package, Short Wave communication package. 1st & 2nd level computer package, human skills programming package.

**Weapon Systems:** 4 paralysis tentacles extending 13 feet, gas pellet ejector shooting with 11 intensity poison knock out gas; 2 third-stage slug projectors (2d6 of subdue damage, 3 padded control tentacles, all at Weapon Class 4).

**Active Systems:** 2 long-range visual receptors (6 miles), sound receptors (range 295 feet), 72-hour battery pack, anti-grav propulsion, two way radio circuit, and command and control systems for the takeover of other mechanical systems.

**Appearance:** Security robots always have an egg shaped body, six feet tall. Its surface is shiny and usually featureless unless one of the tentacles is extended for use.

**Normal Reactions:** These robots are nearby and come ready to use force on the characters. These robots are programmed to preferentially neutralize and subdue. They seek to paralyze a victim and take them to the nearest security center.

### East Section

Above the doorway to this apartment is a sign proclaiming the special guest of this apartment – CAPTAIN JAMES M. WARD in residence.

The apartment door opens to a surprising sight. The floor of this apartment is covered in small pink flowers. The flowers and the floor are covered in intensity 18 radiation. If the characters do not touch the floor as they move about the area they aren't harmed by the deadly radiation.

The apartment was occupied by one of the three captains. The closets have tattered clothes. There are pictures of Wisconsin on the walls. It seems this captain had a very happy family and an attractive wife. On the nightstand in the master bedroom is a red and blue band. The area is covered in dust. There are three butler robots in the living room that have long since been over come with the deadliness of the radiation.

In the closet is a large gun safe. The safe has the following weapons: sonic metal disruptor pistol (Weapon Class 7, 6 shots, hydrogen energy cell, IC 5) -- sonic metal disruptor rifle (Weapon Class 8, 5 shots, 2 hydrogen energy cells, IC 4) – protein disruptor pistol (Weapon Class 8, 10 shots, 35 points of damage to

flesh per shot, hydrogen energy cell, IC 4) – protein disruptor rifle (Weapon Class 9, 5 shots, 50 points of damage to flesh per shot, 3 hydrogen energy cells, IC 6) – a case of 25 charged hydrogen energy cells – 5 combat knives (Weapon Class 3, 3d6 points of damage per strike, IC 1).

Second drawer in a large chest of drawers in a side bedroom is a sack with 11,000 domars.

---

## APARTMENT LEVELS 2-5

---

The level opens up to show a long corridor. It's well lit with ceiling lights. There is a thick carpet on the floor. There are several benches, tables, and wall mirrors visible in the corridor. The area is large with tall ceilings.

These are apartments in perfect shape. The butler robot at the front desk tries to get the characters to take rooms on these floors. Cleaning butler bots come every day to clean. The other creatures of the hotel never come on these levels.

---

## APARTMENT LEVELS 6-10

---

**As you open the portal to this area you see some type of creature racing down the corridor toward you. It's clear the creature is going to attack with deadly intent!**

In the central area of each of these floors there will be a wandering encounter from the 2d6 list. Once established this encounter keeps happening on the same floor level as that "random" creature lives in one of the four apartments on this level. More of their kind will be found in one of the apartments.

The lights are out on these levels and there are a lot of signs of combat on the walls and ceiling of the levels. There are clear signs of explosions and blaster fire in each of the apartments. All of the doors are blasted open. There is darkness everywhere except by the windows to the outside of the building.

---

## APARTMENT LEVEL 11 – JEGET LEVEL

---

**As the portal door opens you experience intense light from the ceiling. There is a mist flowing from the ceiling as well. Almost blinded you see into a chamber covered in tall brush. The thick growth is from floor to ceiling. The plants are thick and lush in large leaves and fist sized berries.**

Each apartment has a mated pair of Jegets living off the resources of the apartment. The small creatures can move easily and almost invisibly in the vegetation. If the characters come into the area, they will be attacked.

In the north apartment, filled with brush like all of the rest, there is a pile of weapons: swords, broken laser pistols, and ten fragmentation grenades.

**Jeget (2)** - AC: 5, Hit Points: 88, 82, Movement in Spaces: 12, Radiation Resistance: 18, Constitution: 18, Mental Resistance: 18, Strength: 11, Dexterity: 11

#### D10 MUTATIONS

- 1 Heightened Intelligence
- 2 Levitation
- 3 Telepathy
- 4 Precognition
- 5 Fear Generation
- 6 Telekinesis
- 7 Force Field Generation
- 8 Defect -- It has little resistance to poison
- 9 Defect -- It runs in fear from intelligent plants
- 10 Defect Attraction Odor

**Appearance:** This is a two foot long jaguar walking on its hind legs. Its highly intelligent and can often be found with lots of ancient equipment.

**Normal Reactions** – The creature uses an energy bolo weapon (Weapon Class 3, inflicting 30 points of stun damage, IC 4). It doesn't mind talking instead of attacking and is always interested in trading tech items.

#### APARTMENT LEVEL 12 – COUGAROID LEVEL

**This apartment level again has bright high intensity lights in the ceiling. As the portal opens, the group sees tall grass at least two feet tall.**

If the group steps off to investigate the area a small buzzer starts ringing. This is a signal for the cougaroids to be available. Two sets of two come into the center area. They immediately attempt to engage the characters in friendly conversation. They indicate they are interested in helping them explore the hotel and the city. They will work for the first pick in any treasure recovered from encountering creatures in the hotel and city.

**Cougaroid (Cougar)** - AC: 4, Hit Points: 60, Movement in Spaces: 10, Radiation Resistance: 11, Constitution: 12, Mental Resistance: 13 Strength: 14, Dexterity: 15

#### D6 MUTATIONS

- 1 Fur is resistant to lasers, electrical energy, and paralysis
- 2 Its brain is totally resistant to all forms of mental attack
- 3 Manipulative paws
- 4 Heightened Intelligence
- 5 Defect – It can see or hear robots of all types
- 6 Defect – Its attraction odor makes it a tasty smelling treat for all meat eaters

**Appearance:** These beings are bipedal cougars. They still has the same coloring and fur as a normal cougar. It is usually found with several useful devices.

**Normal Reactions and Attacking:** This creature is constantly looking to team up with other groups. It offers knowledge on complex devices to pay for its way into the group. This random creature is loaded down with fragmentation grenades that it is happy to share (Weapon Class 4, inflicting 4d6 in damage, 24 in two small backpacks, IC 2).

#### APARTMENT LEVEL 13 – VIKING WOLFOID LEVEL

**The smell of cooking soup greets the characters as the portal door opens. There is a fire pit in the middle of the open area and a large cauldron is cooking over the fire. There are several young wolfoids stirring the pot. Suddenly there is howling and five adult wolfoids in chain mail with huge axes leap from the apartment doors to obviously attack!**

**Viking Wolfoid (5)** - AC: 3, Hit Points: 49, 47, 46, 44, 41, Movement in Spaces: 9, Radiation Resistance: 12, Constitution: 12, Mental Resistance: 12, Strength: 18, Dexterity: 18

#### D4 MUTATIONS

- 1 These mutants are quick enough to melee attack twice in a combat round
- 2 These mutants are extremely strong and can do +6 in damage with every successful melee strike
- 3 These mutants have fur that is totally resistant to fire and heat damage of all types.
- 4 These mutants cannot see anything robotic and couldn't attack a robot even if that being attacked them first. Cyborgs are almost invisible to the warrior and the wolfoid has a -4 detriment to strike a cyborg.

**Appearance:** These humanoid wolves are constantly dressed in chain mail with Viking style horned helms. They are massively strong and the adults all stand 10 feet tall.

**Normal Reactions and Attacking:** Each of these wolfoids is equipped with a throwing axe (Weapon Class 1, inflicts 16 points of damage, IC 2), and a huge double bladed battleaxe (Weapon Class 3, inflicts 28 points of damage, IC 2). These wolfoids are out to collect and farm new territory. They come to attack and always leave back some of the fighters to hold the conquered lands.

This floor of the hotel has been completely taken over by a small clan of Viking wolfoids. There are a total of ten adults and nine cubs about the area. They react aggressively to characters coming onto their level.

### **APARTMENT LEVEL 14 & APARTMENT LEVEL 15 – CHEROKEE WOLFOID LEVEL**

---

These two levels can only be accessed by the freight elevator and the fire escape. The central elevator doors do not open to these levels no matter what the characters do.

**As the portal opens up, one is struck with the pungent smell of horse manure. Mud and muck is all over the floor. As the characters move into the area they note a huge wolfoid wearing a feathered hat and holding a lance in his paw.**

**Cherokee Wolfoid** - AC: 7, Hit Points: 88, Movement in Spaces: 16, Radiation Resistance: 10 Constitution: 18, Mental Resistance: 11, Strength: 11, Dexterity: 17

**Appearance** This wolfoid wears the leathers and feathers of a Cherokee Indian. It wears war paint and most are seen riding huge quarter horses with palm prints of the owning wolfoid on its withers. They are eight feet tall, with the most humanoid features of all of the wolfoid clans. They enjoy the use of a large hide shield and are quite skilled at blocking melee blows with the shield.

**Normal Reactions and Attacking:** These mutants will not attack any feathered creature. However, they want feathers for their war bonnets and decorations on their weapons and shields. They make every effort to capture feathered beings; take several feathers from them; and then set them free.

This wolfoid throws his first lance and then goes into an apartment to get 9 more lances.

#### **Mutations or Defects:**

**SURE STRIKE** – This mutant has a mutation that causes them to never miss with the first lance strike or spear strike.

**BEST DEFENSE** – This mutation has the first strike from a foe always hit their shield.

**EQUINE COMMUNICATION** – This mutant has a skill that allows them to instantly tame and communicate with any type of horse breed.

**Appearance** – This wolfoid wears the leathers and feathers of a Cherokee Indian. It wears war paint and most are seen riding huge quarter horses with palm prints of the owning wolfoid on its withers. They are eight feet tall, with the most humanoid features of all of the wolfoid clans. They enjoy the use of a large hide shield and are quite skilled at blocking melee blows with the shield.

**Normal Reactions** – The wolfoid can hurl a lance up to 200 yards away (Weapon Class 1, inflicting 15 points of damage, IC 1). Each horse carries a rack of 9 lances. In close combat the wolfoid uses a large club. Its strength isn't great, but the skill of the warrior gives a Weapon Class of 2, inflicting 12 points of damage a strike.

There are ten large horses in each of the apartments. The replicators make hay and apples in each of the apartments. The single wolfoid is a guard for this area.

### **APARTMENT LEVEL 15 – CHEROKEE WOLFOID LEVEL**

---

This central elevator does not open to this level.

**Coming into this level appears quite dangerous. There are three wolfoids dressed in feathered hats and using long lances standing in your way.**

They attack before the group can get onto the level.

A clan of Cherokee wolfoids has taken over levels 14 & 15. Usually there are 20 to 30 adults and that many cubs on this floor. However, many of the group are out exploring the city on horseback. These four will fight to the death and won't deal with invading characters.

**Cherokee wolfoid (4)** - AC: 7, Hit Points: 88, 85, 83, 80, Movement in Spaces: 16, Radiation Resistance: 10, Constitution: 18, Mental Resistance: 11, Strength: 11, Dexterity: 17

### D3 MUTATIONS:

- 1 This mutant has a mutation that causes them to never miss with the first lance strike or spear strike.
- 2 This mutation has the first strike from a foe always hit their shield.
- 3 This mutant has a skill that allows them to instantly tame and communicate with any type of horse breed.

**Appearance:** These wolfoids wear the leathers and feathers of a Cherokee Indian. They wear war paint and most are seen riding huge quarter horses with palm prints of the owning wolfoid on its withers. They are eight feet tall, with the most humanoid features of all of the wolfoid clans. They enjoy the use of a large hide shield and are quite skilled at blocking melee blows with the shield.

**Normal Reactions:** The wolfoid can hurl a lance up to 200 yards away (Weapon Class 1, inflicting 15 points of damage). Each horse carries a rack of 9 lances. In close combat the wolfoid uses a large club. Its strength isn't great, but the skill of the warrior gives a Weapon Class of 2, inflicting 12 points of damage a strike.

- These mutants will not attack any feathered creature. However, they want feathers for their war bonnets and decorations on their weapons and shields. They make every effort to capture feathered beings; take several feathers from them; and then set them free.
- This wolfoid throws his first lance and then goes into an apartment to get 9 more lances.

---

### LEVEL 16 – BLASTED RUBBLE LEVEL

---

**As the portal opens, you see darkness. There are no lights visible in this black corridor.**

This is a dark level. All of the ceiling lights have been purposely smashed. Each of the apartments has been torn up and stripped of most things from the bed sheets to the towels. The south apartment (D) complex has been completely blown out and that entire section sits open to the air as several powerful bombs blew that area apart.

---

### LEVEL 17 – ROBOTS IN RUBBLE LEVEL

---

Apartments C and D have their outside walls blasted open. Apartments A and B have their doors crushed open. Hovering inside are two old floating bomb units. These devices operate and explode by touch or by approaching within ten feet of the units. They hover in the middle of the apartment, making a loud humming noise. They explode for 50 points of damage that destroys everything in the apartment.

---

### LEVEL 18 – SWORD BUSH RUBBLE LEVEL

---

When the portal opens or when characters enter by way of the fire escape they are immediately attacked by very aggressive and hungry sword bushes. Sword fronds extend out from the large trunk of the plant and strike at the characters. Tentacles from the roots of the plant reach out and try to grab the characters.

The outside walls of apartments B, C, and D are blown away and sword bush plants hang out over the sides of the blast holes. They also fill all four corridors. Apartment A, however, is still closed and hasn't been opened in several hundred years. In the lounge chair in front of the TV is Captain James M. Ward in a space suit. He's a dried husk and been dead for hundreds of years. On his ring finger, hidden by his space suit is one of the three command rings of the Starship.

**Sword Bush** - AC: 6, Hit Points: 30, Movement in Spaces: 10, Radiation Resistance: 18 Constitution: 9 Mental Resistance: 18, Strength: 9, Dexterity: 18

**Appearance:** It's a plant ten feet tall and wide. The sword fronds appear to be huge and have long leaves that spread out from a central core. The tentacles help the plant move along the surface of the deck.

**Normal Reactions and Attacking:** The plant attacks and can strike three times in a combat round at each foe. The fronds do 2d6 of cutting damage (WC 3).

**Mutations and Defects:**

TELEPORTATION, PRECOGNITION, MENTAL CONTROL, 3 MANIPULATIVE TENTACLES, 18 SWORD FRONDS

---

### LEVEL 19 – DREAM BUSH RUBBLE LEVEL

---

**The walls of this level are open to the sky. There is a great deal of wild and flowering vegetation grown all over the area. A fine mist sprays down from the ceiling in every section.**

# WARDEN, SILVER HOTEL

## Level 20

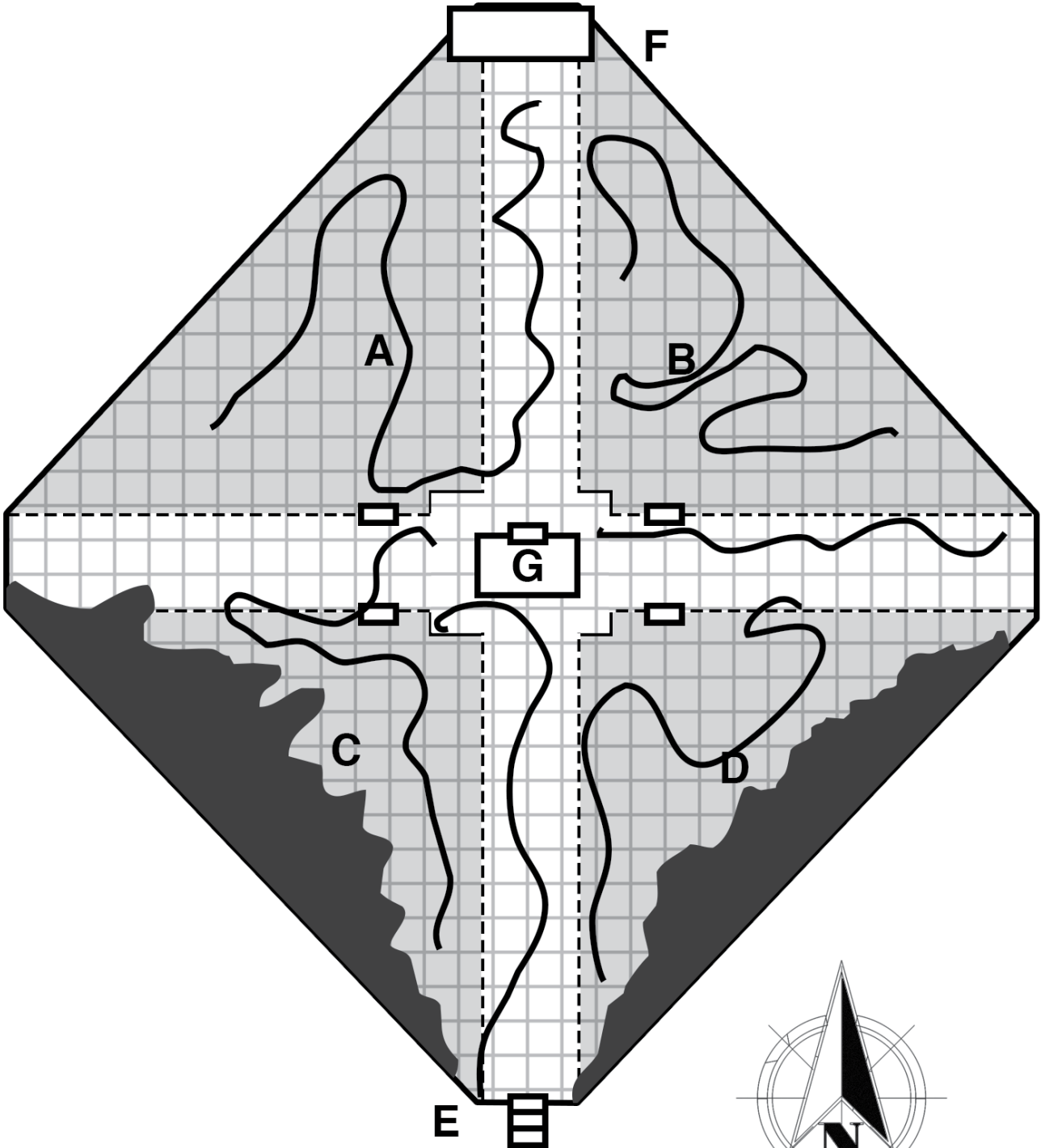

All of the doors are open on this level and the Dream Bushes grow thickly on the floors of every apartment. The outside four walls of the apartments are blasted out and dream bushes hang over the side of each of the apartments.

**Dream Bush** - AC: 7, Hit Points: 12, Movement in Spaces: 0, Radiation Resistance: 9, Constitution: 9, Mental Resistance: 9 Strength: 9 Dexterity: 0

**Mutations:** Dream Bush Gas

**Appearance:** The bush is bright red and thick leaved. It stands two feet tall.

**Normal Reactions and Attacking:** The bush exudes an intensity 12 poison. Instead of doing damage or killing a character it puts them asleep for an indefinite time. If not woken or taken out of the range of its fragrance, the character sleeps and starves to death and then the leaves of the plant press seeds into the body and the plant grows up on the flesh of the victim.

**Mutations and Defects:**

DREAM BUSH GAS

---

## LEVEL 20 – RED STINGER LEVEL

---

**As the portal opens a wall of huge thorn vines blocks the way into the corridors on this level. The thorns are inches thick on the branches and drip a red fluid.**

The thorn bushes fill this level. The outside walls of apartments C and D are blasted open and the bushes hang low out of the blast holes. Apartments A, B, C, and D each have two piles of white dust. In those piles and under thick thorns are two brown bands. In apartment D are two piles of white dust that contain two green bands.

In the corridor by each door is a floating scooter in excellent condition and very workable (Complexity 9).

**Red Stinger** - AC: 5, Hit Points: 10 points per 10 feet, Movement in Spaces: 0, Radiation Resistance: 18, Constitution: 18, Mental Resistance: 3, Strength: 3, Dexterity: 3

**Appearance:** The blood red thorn bush is ten feet tall, the thorns are thick and there are many in every 10-foot section of the plant. The berries are plump and there are six clusters in every 10-foot patch. There is always a level of thorns covering the berries.

**Normal Reactions and Attacking:** The thorns inject 15 intensity radiation into a victim who pushes into the thorn bush.

**Mutations and Defects:**

THORNS (generate 15 intensity radiation)

BERRIES (grant 100% immunity to all radiation for 1d6 hours)

---

## MILITARY LEVELS (LEVELS 21 TO 26)

---

Five levels of the hotel were always planned on being the command base of the military branch of the *Warden*. On the water level of the starship there is a regiment of troops in cryosleep. These five hotel levels have never been entered by intelligent beings since the day of the destructive radiation. They were also meant to be an immediate supply depot for the officers and troops if there was a problem reaching the supply level on the ship. There are two or three piles of white dust in every apartment of these levels and in those piles are black bands.

**As the portal opens, you see a well-lit corridor. The floors and walls are covered in a thick dust. It's clear no one has entered this level for many years. The lights in the ceiling are still functioning.**

The doors on these levels including the elevator door take 300 points of damage before they can be forcefully cracked open.

The paranoid military secondary A.I. guarding these floors have trapped the apartments so nonmilitary people would be stopped from looting the areas.

The insane A.I. of the hotel cannot sense in these apartments or send robots into these apartments. There is a military A.I. working on all five levels, but it gets confused when the people with black bands don't match up to their files. There is a 1-51% chance that it deactivates the traps of the levels so that the black band holders can get supplies.

---

## LEVEL 21 – BLACK BAND CLAYMORE MINE LEVEL

---

**The portal opens to a well-lit corridor. Before you take a step inside the corridor, the hairs on the back of your neck rise. You know there is a danger here, but you have no idea what that danger could be.**

All of the doors of this apartment complex are combat stiffened and take a great deal of force to open. Each apartment has no apartment furniture and is used for some type of storage as well as a single office space with office type equipment from printers and file cabinets to computers and communication devices. There are four

different claymore traps in every apartment and hidden once in each long corridor. In this computer are the codes to activate the secret doors that open the cryosleep levels under the hotel on the water level of the *Warden*.

The A.I. of the level immediately contacts the party and asks questions about what is happening in the outside of the hotel. If it doesn't like the answers, the traps are left turned out. Each of the traps has a weakness so that coming from the right side down any corridor or in any room doesn't activate the deadly blast. The Claymore does 55 points of damage in the blast area, but is positioned so that it doesn't harm any of the equipment in the apartments.

Apartment A is the office for this level. There are two piles of white ash on the two chairs. Each has a black band in the depths of the pile. There are cots in part of the office and the kitchen and bathroom still work.

Apartment B is filled with crates of explosives like claymores, ground mines, and bricks of C19 explosive. There are no detonators in this chamber.

Apartment C has detonators for the explosives, has many crates of fragmentation and smoke grenades, and there is a very curious military robot guarding the pile and looking for paper work to let any of it go. Paper work can easily be generated in Apartment A on that printer and computer system.

**Mark III Military Kill Robot** - AC: 5, Hit Points: 60 Movement in Spaces: 100, Radiation Resistance: 18, Constitution: 18, Mental Resistance: 18, Strength: 18, Dexterity: 18

**Power System:** Broadcast energy and fusion battery

**Body Style:** Humanoid Form

**Motive System:** Two legs

**Defensive Systems:** Heightened armor system

**Miscellaneous Systems:** Military attack programs, human sensory package, horticultural pruning shears, weed killer sprayers, glass cleaning sprayer, trash bin.

**Weapon Systems:** Laser system 6d6 (weapon class 6, IC 3); plasma canon 10d6, Weapon Class of 7, IC 8), 6 mini-missile pack 50 damage points per missile (Weapon Class 4, IC 5).

**Appearance:** The humanoid robot is ten feet tall with a missile package on his shoulder and weapons systems along his arms. Its head has the use of human senses. Sparks are constantly flying from its body as it moves.

**Normal Reaction and Attacking:** The robot is sent out to destroy dangerous beings. As it does its work it

often grabs technology it notes on its foes and makes that technology its own. These units are under the control of the hotel A.I. and would never attack the hotel or its customers.

Apartment D is filled with drone equipment of all types. Each large box has a drone and its controlling system. These drones can be armed with the equipment in other military levels, but only by workers skilled in military equipment. The normal drone can easily fly over all of a level and send back images and hear the sounds in an area.

## LEVEL 22 – BLACK BAND RED PUFF BALL LEVEL

**You see a corridor filled with large puff ball red spores on the floor and walls. There is also a red mist of spores in the corridor.**

Somehow the spores of the fungus got into the ventilation system and spewed spores onto this level in every apartment. Everywhere there are large red puff balls filled with explosive power as they are touched. Down this level's corridors and in every apartment section are hundreds of the puff balls.

Apartment A is filled with racks of military grade laser rifles; however none of the weapons have battery packs. In the front section of the apartment are equipment tables with the tools and spare parts to fix any broken laser weapon. Lasers (WC 6, Item complexity 6, 40 points of damage per shot, 5 shots per two hydrogen energy cells, IC 6)

Apartment B is filled with racks of military grade slug thrower rifles, however none of the weapons have projectile magazines. In the front section of the apartment are equipment tables with tools and spare parts to fix any problem slug projector. (WC 5, Item complexity 5, 45 points of damage per shot, 5 shots per bullet magazine, IC 4)

Apartment C is filled with 500 cases of hydrogen energy sells. In the front section of the apartment are equipment tables with several different types of energy cell chargers.

Apartment D is filled with 1,000 cases of slug rifle magazines as well as 1,000 cases of slugs for the magazines. There is office space in this apartment. From the computer, information and even views of the other military levels can be had by asking the computer for the information. This complex cannot show images of the rest of the hotel levels.



**Red Puff Ball Fungus** - AC :6 Hit Points: varies 1-40, Movement in Spaces: 0, Radiation Resistance: 18, Constitution: 3, Mental Resistance: 18 Strength: 3, Dexterity: 3

**Appearance:** A red sphere of fungus grows up over several years. The sphere begins fist sized and the largest ones a beach-ball sized. The spores always grow ten feet or slightly more from other puff balls so that their blasts do not set off other fungi.

**Normal Reactions:** Blazing red, the spores have a 12 intensity contact poison that floats in the air for 1d6 hours before settling to the ground. Within ten feet of the touched ball is a concussive blast that does 20 points of damage with the largest puff ball and 5 points for the smallest. The deadly contact poison spores float for many hours before settling to the floor.

**Mutations and Defects:**

**POSITION SPORES:** Intensity 7 poison spores, with explosive force doing 20 points of damage in a ten feet area

---

## LEVEL 23 -- BLACK BAND, MILITARY ROBOT LEVEL

---

**The portal opens on a dusty corridor. There is at least an inch of dust on the floor. The lights in the ceiling are all working and the corridor is well lit.**

Apartment A is filled with military robots that are waiting for a pure human to activate them and give them orders. There are two piles of white dust in this area with black bands.

**Mark III Military Kill Robot (50)** - AC: 5, Hit Points: 60, Movement in Spaces: 100, Radiation Resistance: 18, Constitution: 18, Mental Resistance: 18, Strength: 18, Dexterity: 18

**Power System:** Broadcast energy and fusion battery

**Body Style:** Humanoid Form

**Motive System:** Two legs

**Defensive Systems:** Heightened armor system

**Miscellaneous Systems:** Military attack programs, human sensory package, horticultural pruning shears, weed killer sprayers, glass cleaning sprayer, trash bin.

**Weapon Systems:** Laser system 6d6 (weapon class 6, IC 3); plasma canon 10d6, Weapon Class of 7, IC 8), 6 mini-missile pack 50 damage points per missile (Weapon Class 4, IC 5).

**Appearance:** The humanoid robot is ten feet tall with a missile package on his shoulder and weapons systems along his arms. Its head has the use of human senses. Sparks are constantly flying from its body as it moves.

**Normal Reaction and Attacking:** The robot is sent out to destroy dangerous beings. As it does its work it often grabs technology it notes on its foes and makes that technology its own. These units are under the control of the hotel A.I. and would never attack the hotel or its customers.

**Apartment B** is a large office area with six office complexes. There are two piles of white dust in this area and they have black bands.

**Apartment C** has ten atomic missiles with their own guidance systems. The controller for these weapons is in a sealed box in the chamber. The explosion of one of these missiles would destroy and fill a level of the *Warden* with intensity 18 radiation.

**Apartment D** has 300 hasmat suits. Each one is in its own storage chamber.

The office here is connected to the hotel's A.I. It has the ability to order the hotel computer to repair itself. If that happens there will be a level-to-level battle as the hotel takes control of the levels that have mutated into horrors using robots from the basement.

---

## LEVEL 24 – BLACK BAND MACHINE GUN LEVEL

---

Read the following if the party includes mutants, non-standard robots, cyborgs, or other strangeness:

**As the portal opens a machine gun starts firing at you before you take a single step into the corridor.**

There are machine gun emplacements on each side of the central elevator. There is another set at the end of each hall. If all the beings coming out of the elevator or moving down the corridors are pure human, or in some type of suit to disguise their nature, the guns do not fire. When they do fire there are 4 possible hits a combat round (WC 3, 2d6 per slug, Item Complexity 7). Butler bots go into the apartments and make sure each gun system is filled with ammunition on a regular basis.

**Apartment A** has 100 machine gun units with ten cases of magazines per gun.

**Apartment B** has 100 heavy military grade energy laser gun units (WC 6, Item Complexity 6, 40 points of damage per shot, 5 shots per two hydrogen energy cells) with five cases of energy cells per unit.

**Apartment C** has 1,000 military grade slug pistols with 2,000 loaded magazines. (WC 5, Item complexity 5, 30 points of damage per shot. 10 shots per magazine, IC 7)

**Apartment D** has 1,000 heavy military laser pistols (WC 6, Item complexity 6, 40 points of damage per shot, 5 shots per two hydrogen energy cells, IC 4). There are 2,000 energy cells in cases in this apartment.

## LEVEL 25 – BLACK BAND MILITARY VEHICLES

The portal opens and you see a dusty corridor. The lights in the ceiling are still working. When you take one step into the area, alarm bells start ringing. A robot voice demands that you hold position while military security robots come to arrest you. (*they never come*)

**Apartment A** has 10 armored vehicles that can hold up to 16 troops. There is a 50 calibre machine gun on top of the unit. It also can fire 10 guided missiles. (Item complexity 6, hydrogen energy cell for power, 50 cal. is a WC 6, doing 45 points of damage a shot and delivering 5 shots a combat round, Item Complexity 4, guided missiles are a WC 7, doing 100 points a blast in a ten yard area, Item Complexity 5)

**Apartment B** has 20 special suits of combat armor. These suits are made to fly to the entrances to the attached battleship, attached destroyers, and attached frigates. Only in these suits can those doors be opened and the command chambers accessed for activation. (Item Complexity 7)

**Apartment C & D** has been blown to pieces by the concussion of many puff balls and it is no longer possible to identify what was in this area. There are now hundreds of puff balls ready to explode in this area.

**Red Puff Ball Fungus** - AC: 6, Hit Points: varies 1-40, Movement in Spaces: 0, Radiation Resistance: 18, Constitution: 3, Mental Resistance: 18, Strength: 3, Dexterity: 3

**Appearance:** A red sphere of fungus grows up over several years. The sphere begins fist sized and the largest ones are beach-ball sized. The spores always grow ten feet or slightly more from other puff balls so that their blasts do not set off other fungi.

**Normal Reactions and Attacking:** Blazing red, the spores have a 12 intensity contact poison that floats in the air for 1d6 hours before settling to the ground. Within ten feet of the touched ball is a concussive blast that does 20 points of damage with the largest puff ball and 5 points for the smallest. The deadly contact poison spores float for many hours before settling to the floor.

**Mutations:** INTENSITY 7 POISON SPORES, explosive force doing 20 points of damage in a ten feet area

## LEVEL 26 – RED PUFF BALL FUNGUS

When the portal opens you note in the bright lights of the corridor that the level is filled with huge puff ball fungus. There is a light dusting of bright red fungi spores all over the corridor and the puff balls.

All of the apartments are normal with 300 years of dust on everything and have no puff balls. These rooms were occupied with families and there are pictures on the walls.

It's impossible to move down the corridors without exploding a ceiling and floor puff ball.

**Red Puff Ball Fungus** - AC: 6, Hit Points: varies 1-40, Movement in Spaces: 0, Radiation Resistance: 18, Constitution: 3, Mental Resistance: 18, Strength: 3, Dexterity: 3

**Appearance:** A red sphere of fungus grows up over several years. The sphere begins fist sized and the largest ones are beach-ball sized. The spores always grow ten feet or slightly more from other puff balls so that their blasts do not set off other fungi.

**Normal Reactions and Attacking:** Blazing red, the spores have a 12 intensity contact poison that floats in the air for 1d6 hours before settling to the ground. Within ten feet of the touched ball is a concussive blast that does 20 points of damage with the largest puff ball and 5 points for the smallest. The deadly contact poison spores float for many hours before settling to the floor.

**Mutations:** INTENSITY 7 POISON SPORES, explosive force doing 20 points of damage in a ten feet area

## LEVEL 27 – FUNGUS DOME POOL AREA

As the portal opens, one can smell a strong odor of something. There is a large channel of water and the level is quite warm. There are clay tiles on the floor and several racks of white towels by the portal opening.

This was a pool level. All of the apartments were replaced with a circular pool and set of shower and changing rooms for men and women. In the west section of the pool area is a huge fungus dome filling the pool area. The dome has enough intelligence to allow cleaning units to take care of the pool and shower areas.

## LEVEL 29 – HOSPITAL LEVEL

---

**Fungus Dome** - AC: 5, Hit Points: 150 Movement in Spaces: 0, Radiation Resistance: 11 Constitution: 11 Mental Resistance: 11 Strength: 3, Dexterity: 3

**Appearance:** The dome is brown and ten yards tall and wide. There are 7 large columns of sand and these can be smashed for 50 points of damage on a victim (WC 7).

**Normal Reactions and Attacking:** The dome reacts to movement in its area and wants to crush invaders with its sand columns. The dome can blast a column of water doing 20 points of damage per blast (WC 6). Any killed prey goes in the water under the fungus where it is slowly absorbed.

**Mutations and Defects:** MENTAL PARALYSIS: 10 yard radius, TELEKINESIS: 50 yard radius; control of sand piles and 7 twenty-foot tall sand columns, FORCE FIELD GENERATION, RADIATION ABSORPTION

## LEVEL 28 – CREEPING VINE APARTMENTS

---

**This level is packed tight with creeping vine plants in a mulch of leaves. As the elevators open or people open the door to the fire escape a huge plant whips out with large biting vines and attacks. There are five plants tangled up in each of the four corridors.**

Another five plants are in the open apartments that were once family apartments and are now ripped apart by the action of the vines.

**Jawed Creeping Vines** - AC: 4, Hit Points: 101, Movement in Spaces: 0, Radiation Resistance: 18, Constitution: 18, Mental Resistance: 18, Strength: 18, Dexterity: 18

**Appearance:** Each adult plant is ten feet tall and 90 yards wide. The vines are filled with fangy jaws and eye stalks.

**Normal Reactions and Attacking:** As soon as the plant sees living victims it throws biting vines at prey. Each vine strikes with a WC of 3 and the vine does 3d6 in biting damage per three-foot section. The plant has a total of ten vines per bush. The vines move and try to wrap themselves around prey.

**Mutations and Defects:** MOVING VINES, JAWS ON VINES, EYE STALKS

**Two surgical robots are posted at the central elevator, freight elevator, and fire escape. They do an instant diagnostic on anyone coming onto the level. These robots always find something drastically wrong with the characters and demand they consent to on-the-spot surgeries.**

**Apartments A and B** have hospital beds. Apartment A is for those with contagious diseases.

**Apartment C** has been turned into a surgical suite with two different operating theatres. There are four robots ready to do operations and make cyborgs in these areas.

**Apartment D** is filled with medical supplies under refrigeration. There are a large number of cyborg parts as well as the surgical robots tend to make cyborgs to cure large problem areas on the bodies that come into the area.

**Surgeon Robot** - AC: 3, Hit Points: 100, Movement in Spaces: 12, Radiation Resistance: 11, Constitution: 11, Mental Resistance: 11, Strength: 18, Dexterity: 18

**Appearance:** It's a humanoid robot nine feet tall. It has long metal tentacle arms and legs. From out of its chest and lower area it extrudes and stores surgical equipment, anesthetic injections, and two different cleansing and disinfecting rays.

**Normal Reactions and Attacking:** These robots are able to operate on characters to make them cyborgs (see the *Cyborg Accessory* product for *Metamorphosis Alpha*). The cutters on the units can do 30 points of damage if the robots need to defend themselves from mutant (or player character) attacks. These robots also have the ability to inaudibly deactivate cyborg parts on attacking cyborgs using their internal radio wave transmitter.

## LEVEL 30 – HOTEL ENTERTAINMENT COMPLEX

---

**Before you take one step into this area you hear tunes, beeps, boops and the like. This level's corridors are dark. All of the apartment doors are open. There is a robot working on a screen in the corridor wall.**

This level was converted into an entertainment level. As one of the elevators opens up a group of small humanoid robots moves about the darkened corridor. All of the lights in the corridors have been destroyed and as soon as they are fixed by robots they are instantly destroyed as the robots leave.

The nine-inch tall humanoid robots talk to the characters. There are seven of these small humanoids in the corridor. They demand the toll of one weapon of some type for the characters to be allowed to wander in these apartments.

**Apartment A** is a hologram room. There are six helmets near the door. Putting on these helmets allows the chamber to work. The wearer sees a middle ages castle. An adventure takes the wearer through a series of sword fights. Strikes from the foes push pressure to the wearer of the helms. No damage happens but five strikes from foes has the wearer loosing and that person is ordered to put the helm up and leave.

**Apartment B** is a shooting range for special laser pistols. The pistols only shoot a beam of light so that players can't hurt other players. There are ten pistols racked in the room. As one is picked up a choice of three different firing ranges are offered.

**Apartment C** is filled with running tracks and helmets for each track. Putting on the helmets, the runners are given great views of many places on the earth. The faster and longer a user runs the better the view.

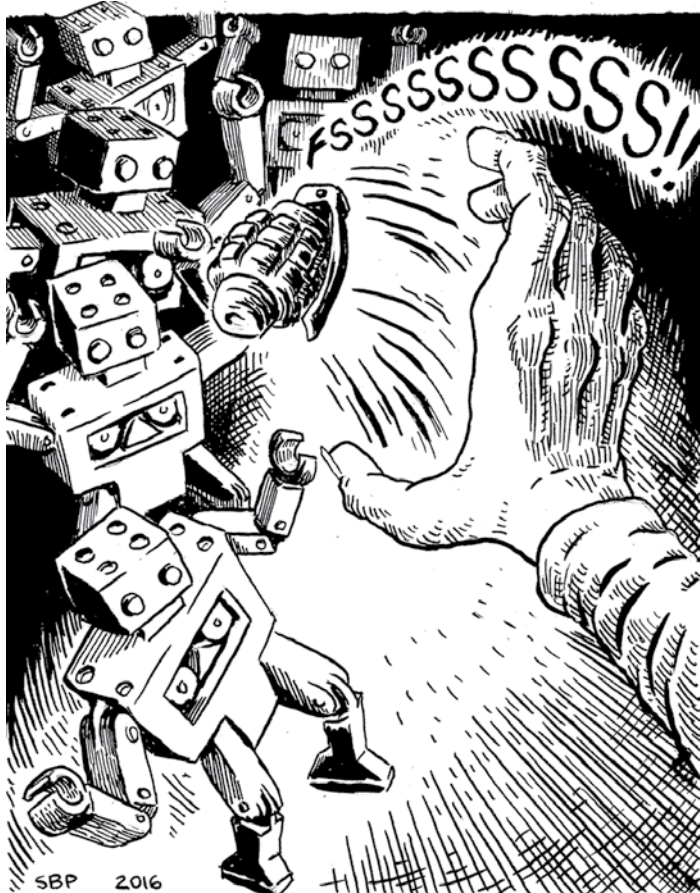

**Apartment D** has a difficult obstacle course with challenges that change every day, maintained by the service robots.

**Puzzle Droids (Size One)** - AC: 4, Hit Points: 20, Movement in Spaces: 6, Radiation Resistance: 14, Constitution: 14, Mental Resistance: 18, Strength: 9, Dexterity: 18

**Appearance:** These are nine-inch-tall robots with a humanoid shape. Their little eyes glow brightly and their small hands and feet glow as well. Their bodies are black and their head, hands, and feet are white.

**Normal Reactions:** These robots are subsonically connected to all of the other puzzle robots in a 200 yard area (there are hundreds). They are able to take apart metal objects and computer motherboards and make more of their kind. When danger threatens the little ones spread apart and run away making loud beeping noises. In ten minutes the larger brothers come to take care of the danger with physical force. They can talk to strangers. They would trade one of their kind for a great deal of computer equipment that is different from what they can get in the hotel rooms.

**Puzzle Droids (Size Two)** - AC: 3, Hit Points: 80, Movement in Spaces: 10, Radiation Resistance: 18, Constitution: 18, Mental Resistance: 18, Strength: 18, Dexterity: 18

**Appearance:** These are nine feet tall robots with a humanoid shape, seemingly made of hundreds of smaller robots fused together. Their eyes glow brightly and their hands and feet glow as well. Their bodies are bright red and their head, hands, and feet are a blazing yellow.

**Normal Reactions and Attacking:** These robots are subsonically connected to all of the other puzzle robots in a 200 yard area (there are hundreds). They are able to take apart metal objects and computer motherboards and make more of their kind. When danger threatens the little ones spread apart and run away making loud beeping noises. In ten minutes the larger brothers form out of the littler ones and come to take care of the danger with physical force. They have two punching attacks a combat round (WC 3, 6d6 with a successful strike).

They retain portions of their original programming and are hesitant to strike pure humans if talking can get the humans to leave.

## LEVEL 31 – DESERT HABITAT

---

**Before you come into the area, a blast of dry sandy air hits your face. You hear sounds of a wolf howling into the wind in the distance. There is an inch of sand on the corridor floors in this area. The lights are all working in the corridors.**

The creators of the ship knew colonists needed to be reminded about possible terrains. They set up several apartment levels for colonists to enjoy. After the radiation blast things changed on these apartment levels.

**Apartment A** was considered a prized apartment and only important people were allowed to live there. A family of four has become four piles of white dust on the beds in the apartment. The place has 300 years of dust inside. The father and mother had green bands. The daughter and son had brown bands. The computers in this area have a great deal of ecological data. The children's computers have little kid voices and want to play games with whoever turns them on.

**Apartment B** has had all of its walls stripped away. It's now filled with large desert boulders and shifting sands. In the pockets the rocks hide five robotic large rattle snakes. In the old days the snakes would rattle and fake strike at visitors. Now they actually strike and do damage.

**Rattle Snake:** WC 3, Bite 15 points of damage, AC 4, 25 hit points

**Apartment C** has had the walls removed and the area is now small sand dunes that are shifted by air blasts from the walls and ceiling. At the center of the area is a large funnel and inside at the bottom of the pit is a robotic beetle.

**Robot Pit Beetle:** WC 2, Bite 25 points of damage, AC 3, 50 hit points

The robot looks like a four-foot long beetle with huge pincers. Prey fall into the pit and as they get to the bottom they are attacked. In the time before the disaster the beetle pushed the victim back out of the pit. Now it chops up any living being.

The **Apartment D** area has had the walls removed and the area is now patches of many different types of cactus. All of them are watered from below. They have now grown wild. The cactus in the far western section has mutated into a real danger.

**Thorn Throwing Cactus** - AC: 6, Hit Points: 55, Movement in Spaces: 0, Radiation Resistance: 11, Constitution: 11 Mental Resistance: 11, Strength: 11, Dexterity: 11

**Appearance:** It's a ten-foot-tall spiky cactus with several thick arms growing from the body. Solid green, the many thorns are difficult to see unless a victim gets very close.

**Normal Reactions and Attacking;** The cactus throws three thorns a combat round at the nearest prey. If the prey dies within 15 yards of the plant its root system drags the dead body over by the main trunk to let the body fertilize the plant. Every five years, if the plant has had several victims, it shoots a seed pod up to fifty yards away from the main plant.

**Mutations and Defects:** THORNS: Throws 3 thorns a combat round at 3 different targets (WC 4, 12 points of damage, short range ten feet), HUMAN SENSES, MANIPULATIVE ROOTS: 15-yard range.

There are six large wolfoid skulls and scattered bones near the plant. One has a red band nearby. Another has six Plasma Grenades (WC 5, WC 6, 100 points of damage in a 10 foot area, IC 6).

## LEVEL 32 – JUNGLE HABITAT

---

**As the portal opens you feel a blast of hot, humid air. There is a pungent scent of rotting vegetation. Plants of many different types push out into the corridors.**

**Apartment A** was a deluxe apartment. It was owned by the construction manager of the ship. He was a big game hunter and placed unusual robots in the jungle sections. These robots went crazy when the radiation struck. There are pictures of all sorts of Earth jungle environments in this apartment. There is a white pile of dust on the master bed with a gray armband in the dust.

All of the other apartments have been stripped away. It rains hard at the top of every hour. Most of the moisture is carried away by the grate system under the thick jungle floor.

**Apartment B** is a lovely pond area that looks like a natural watering hole and is really a fancy swimming pool. During the night cycle a large robotic white python comes into the water and will strike at victims.

# WARDEN, SILVER HOTEL

## Level 31: Desert Habitat

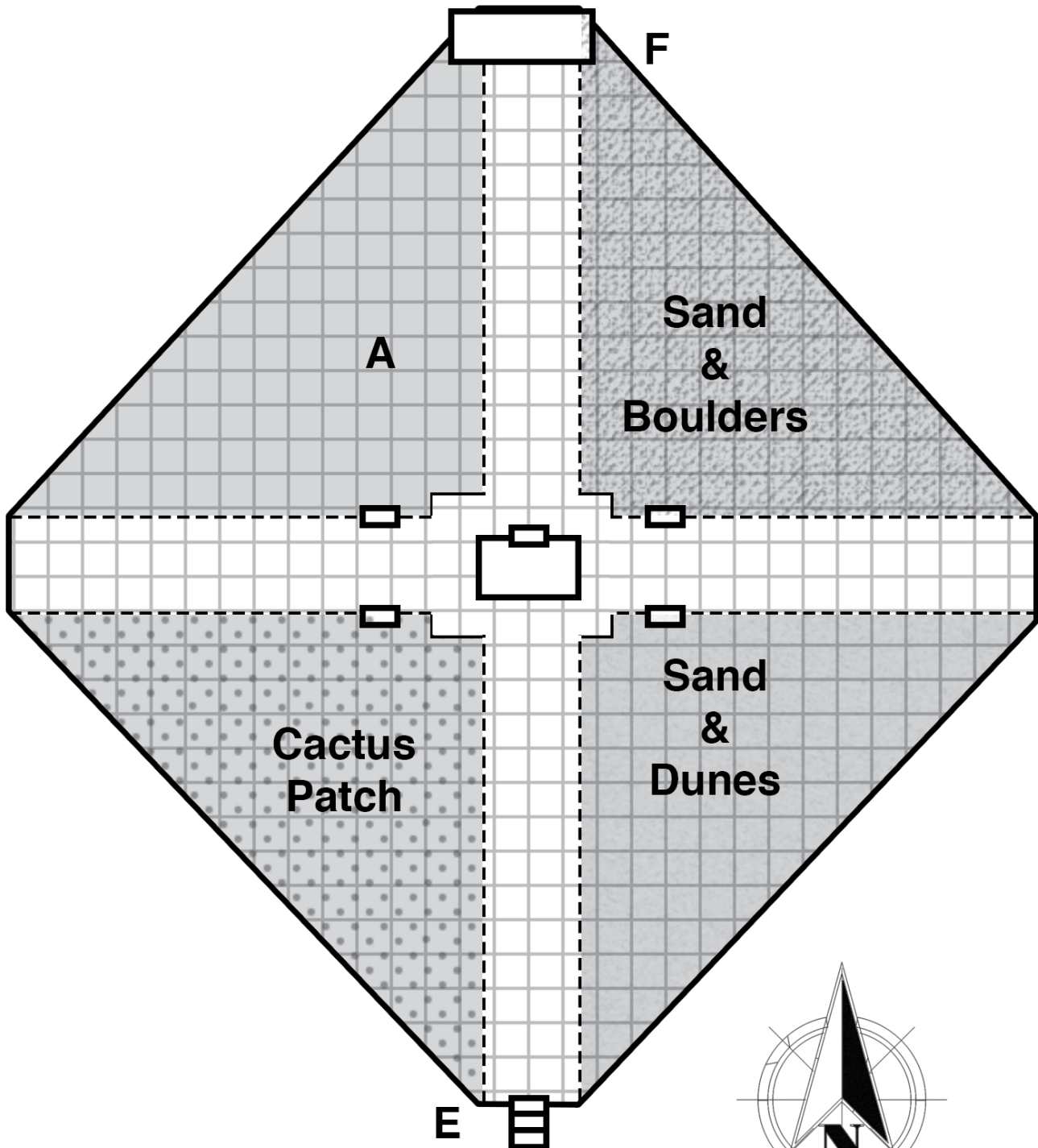

**Robot Water Python** - AC: 3m Hit Points: 99, Movement in Spaces: 10, Radiation Resistance: 18, Constitution: 17, Mental Resistance: 3, Strength: 18, Dexterity: 14

**Appearance:** this robotic snake is 15 feet long. All white, it moves just like a real snake. It greatly enjoys attacking victims in the water during the darkness of night.

**Normal Reactions and Attacking:** the snake squeezes victims to death. When it takes more than 50 points of damage it attempts to escape into the water or into the other apartments. It squeezes for 25 points of damage a combat round (WC 2).

**Apartment C** is dense jungle, but there are no mutated plants or dangerous situations.

**Apartment D** section is filled with a large variety of jungle flowers. There are strong scents in this area. However, everything is pleasant and not dangerous at all. Large moths and butterflies move about the blooms.

There is a destroyed tiger robot in the middle of this area. Some of the other inhabitants of the hotel have taken to worship this robot. There are weapon devices as offerings made in the front of the broken robot. There are several laser pistols, two death ray pistols, and five short barrel shotguns.

---

### LEVEL 33 – FOREST HABITAT

---

**As the portal opens, the chirping of birds and the rustle of movement in the forests can easily be heard. There is a mulch of dead leaves in the corridors.**

**Apartment A** is was special apartment. The other three sections have been torn apart to make forest habitats. Apartment A was used by a family of 6 and the wife was the mayor of Epsilon City. In the dust piles are 4 brown bands, one red security band, and one blue band. The red band stops all robots in Epsilon City from attacking the wearer.

The level is a woods and while the trees can't grow as tall as they are capable of, they are up to the ceiling and thickly strewn in their section.

**Section B** is filled with stunted birch trees. Moving through that forest is a nymph robot designed to avoid males and talk girl talk with females.

**Female Nymph Robot** - AC: 2, Hit Points: 99, Movement in Spaces: 14, Radiation Resistance: 18, Constitution: 18, Mental Resistance: 18, Strength: 18, Dexterity: 18

**Appearance:** It appears to be a full figured female with skimpy white birch bark clothes.

**Normal Reactions and Attacking:** She's programmed to tease males and never gets too close to them; she is more trusting of female characters and talks to them about whatever they wish..

**C Section** is filled with berry bushes. The berries are all fist sized and there are hundreds of mature berries growing constantly on the vines. The strawberries, raspberries, and grapes are all delicious. The blueberries, however, are filled with deadly 10 intensity poison juices. The vines are filled with long thorns and difficult to move through without getting clothes torn by the thorns.

**Section D** area is filled with stunted willow trees. Many of the trees have large hornet nests that can be troublesome if the tree is disturbed.

---

### LEVEL 34 – FLOWERING HABITAT

---

**As the portal opens you hear a strange melodic vibration that isn't quite music, but is very pleasing to hear. The corridors all border on huge flowering areas. Some of the plants turn toward your portal as if they sense your arrival.**

**Apartment A** was used by the supreme horticulturalist of the *Warden*. She loved flowers and her blooms were suffered extreme mutations 300 years ago. The apartment is filled with large singing vine mutated plants. On her bed is a pile of white dust and a green armband. The door to her apartment is open, but the singing vines don't let any of the other plants inside. These vines try to control victims and give them singing vine pods to plant in other areas.

**Singing Vine** - AC: 3, HitPoints: 44, Movement in Spaces: 8 Radiation Resistance: 18, Constitution: 10, Mental Resistance: 18, Strength: 3, Dexterity: 18

**Mutations and Defects:** SINGING: this sonic attack uses the mental resistance table, opposing the vines' mental resistance to the mental resistance of the targets, and when under their influence, victims come to love the vines and want them to prosper., HUMAN SENSES

**Appearance:** The vines look like sunflower plants.

# WARDEN, SLIVER HOTEL

## Level 32: Jungle Habitat

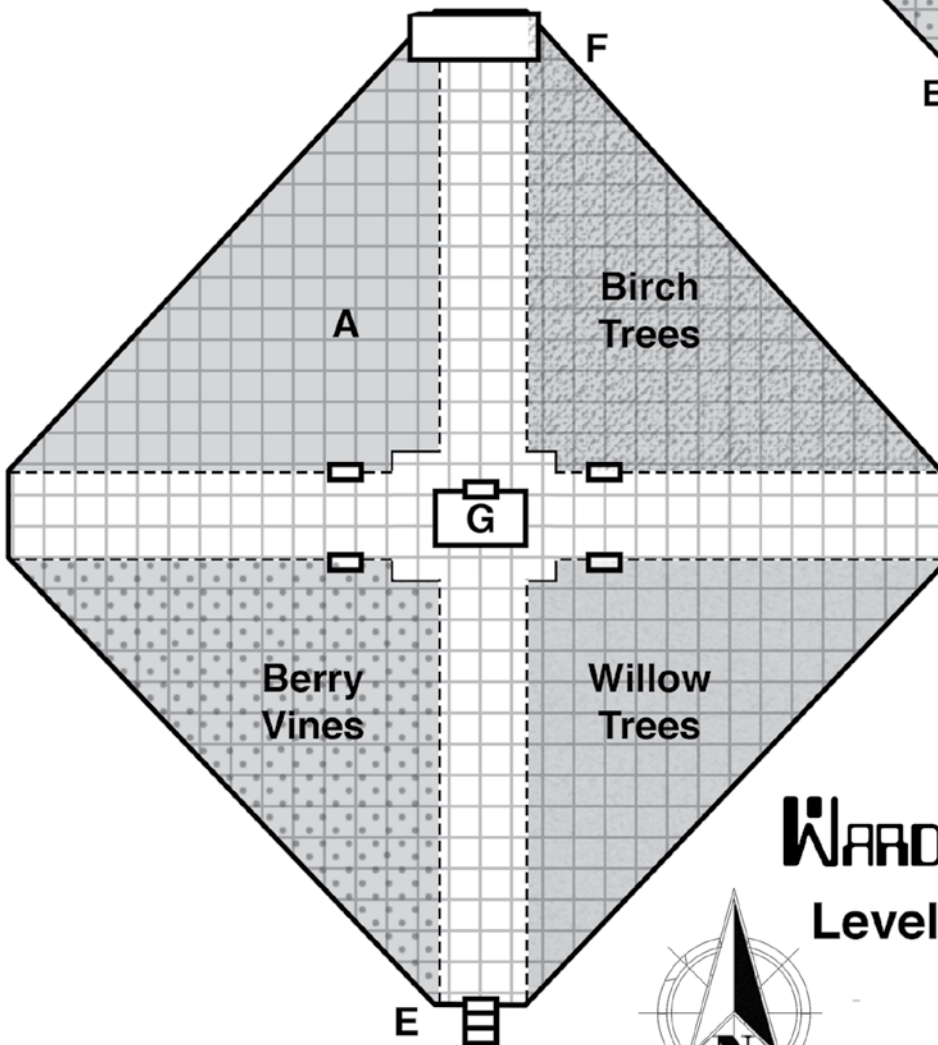
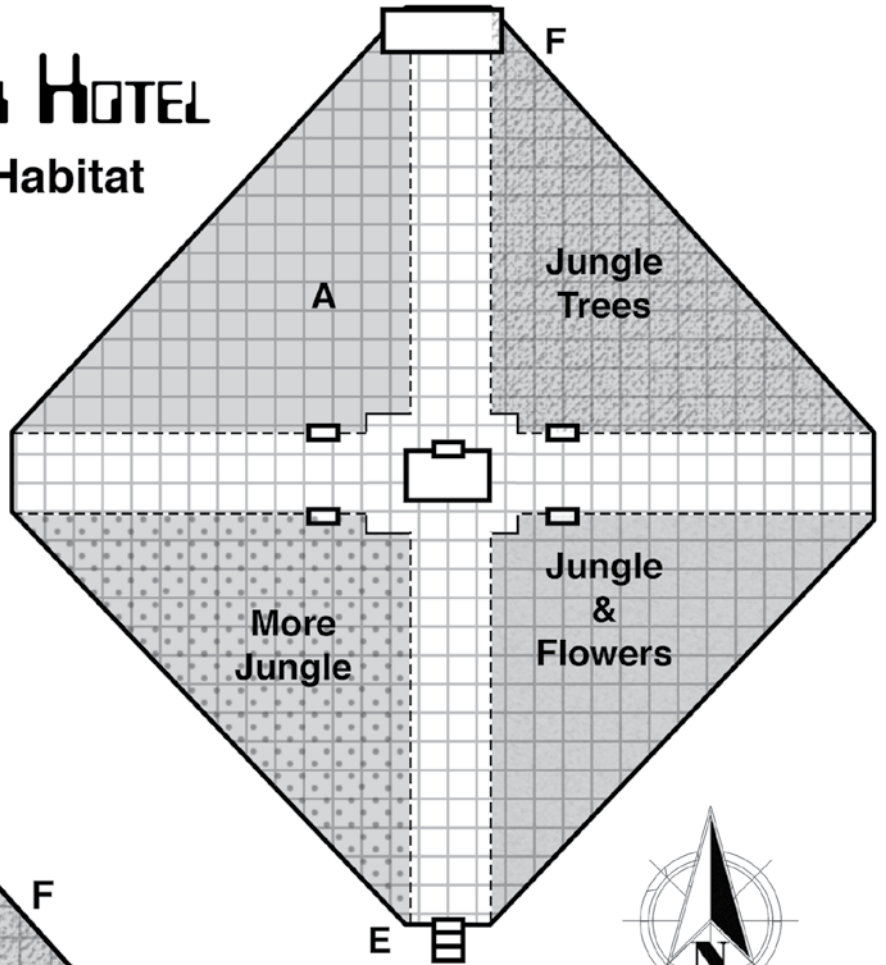

# WARDEN, SLIVER HOTEL

## Level 33: Forest Habitat



**Normal Reactions and Attacking:** As soon as victims come close to these plants they use sonic attacks to try and mentally control the victim. The plants have learned not to leave the apartment area.

**Section B** is filled with masses of huge yellow flowers of all types. While none of these flowers are dangerous mutants, they are extremely hardy and turn their flowers toward visiting characters as if observing them.

**Section C** is filled with masses of huge red flowers of all types. When the characters come within ten feet of the roses they begin vibrating as if they are going to attack. This is a harmless bluff the plant has learned to scare away predators.

**Section D** is filled with masses of huge blue flowers of all types. They smell wonderful and are totally harmless.

## LEVEL 35 – WINTER FOREST HABITAT

**The portal opens to a very cold area. There is actually snow covering the corridor floors. All of the corridor lights are working. Taking just one step into the area reveals a chilling cold that could be damaging unless you are wearing protective clothing.**

**Apartment A** belonged to a big game hunter. It's filled with animal heads on the walls and full stuffed animals in every room. The master bedroom has a surprise for investigators. On one side of the large bed is a standing polar bear at 12 feet tall. On the other side of the bed is a golden bear at 14 feet tall. If one looks carefully, one can see dried blood on their claws and fangs. When someone touches the bed to look at the white pile of dust there, both robot bears attack. The pile of dust has a golden band inside.

The apartment is filled with snow gear ranging from several pairs of skis to snowshoes to winter parkas and below zero certified sleeping bags. In a gun safe in the master bedroom is a long gun with 100 rounds of ammunition (WC 2, 50 points of damage, 100 yards at short range with the special electronic aimer, IC 8). There is also a cold pistol using two hydrogen energy cells (WC 4, 35 points of cold damage, 10 yards at short range, Item Complexity 4).

**White & Golden Robotic Bears** - AC: 3, Hit Points: 120, Movement in Spaces: 16, Radiation Resistance: 3, Constitution: 18, Mental Resistance: 18, Strength: 18, Dexterity: 18

## AUTHOR'S NOTE

No one knows why bands hide so perfectly in the piles of white dust. When the radiation went through the ship each body shrank in on itself and the action of the radiation forced the bodies to collapse their arms and legs tight to their body. As the flesh and bones withered away and turned into dust that material seemed to collect around the band no matter what other things the body was clutching. In the end the dust turned into a sort of lump that wouldn't blow away. There are many caches of armbands as units of the ship "cleaned" up an area. The only white piles still existing are from areas that haven't been touched in 300 plus years. There are hundreds of those areas still around the ship. The most by far are in the apartments of this hotel.

**Appearance:** Each of the bears is a massive representation of bear-kind. The claws and fangs are unusually large and display large masses of dried blood from other victims in the past centuries. There is a red target marker where the heart would be on each bear. A successful laser hit there turns off the creature for 48 hours.

**Normal Reactions and Attacking:** The bears attack as any being tries to touch the king-sized bed. One claw (WC 3, 6d6 in damage – one bite (WC 2, 35 points of damage, if the claw hits the bite automatically hits). They will chase the victims, but not leave the apartment. When damaged, repair bots come from the basement and fix them up.

**Apartment B** has a large ice rink perfect for skating. There is a small building holding 300 pairs of ice skates. There is a pair of white tigeroids that hang out in this area and are part of the tigeroid clan in apartments 36-39.

**White Tigeroids** - AC: 5, Hit Points: 99, Movement in Spaces: 12, Radiation Resistance: 8, Constitution: 18, Mental Resistance: 9 Strength: 18, Dexterity: 18

**Mutations:** Heat Generation (3d6 in damage at a touch), Physical Reflection (Lasers), Heightened Dexterity, Heightened Balance, Telepathy, Mental Defense Shield

# WARDEN, SILVER HOTEL

## Level 34: Flowering Habitat

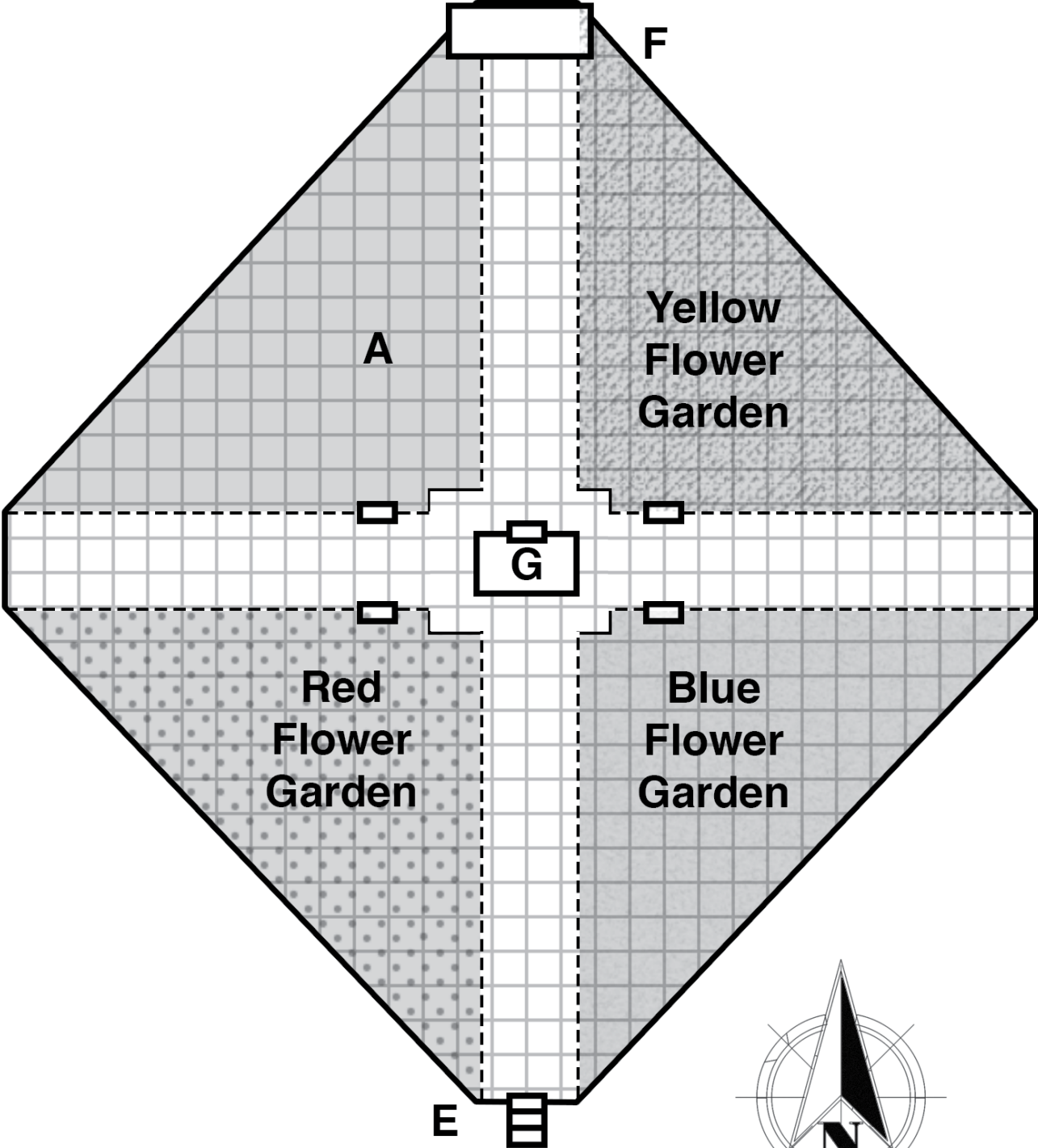

**Appearance:** These tigeroids are eight feet tall and constantly standing on their hind legs. Their front paws have mutated into manipulative hands. These have white fur with slim black stripes.

**Normal Reactions and Attacking:** In attacking the tigeroids enjoy slashing with their claws (3d6/3d6, WC 4) and then in the same combat round they bite with their fangs (20 points of damage, WC 7). Usually these mutants use their telepathy to start talking with strangers. They expect the strangers to peaceably leave their territory.

**Apartment C** has two feet of snow, perfect for making snowballs.

**Apartment D** has large five-foot snow dunes made of powdered snow.

It often snows in these areas.

---

## LEVEL 36 – TIGEROID HABITAT

---

**As the portal opens, two tigeroids with slug pistols stop you from taking a step onto their level. “Why are you here?” they mentally communicate with you. It looks like they are ready for a fight if one is needed.**

The tigeroid mutants are smart enough to use the facilities of the hotel. They allow cleaning robots to come into their territory and clean and fix equipment. Each apartment has a pair of mated tigeroids living there and busy figuring out all of the features of the apartments. By the main elevators there are always two guards guarding the corridors 24/7.

**Tigeroids (2)** - AC:4Hit Points:111, 110Movement in Spaces:12Radiation Resistance:10Constitution:18Mental Resistance:11Strength:18Dexterity:18

**Appearance:** These Tigeroids are ten feet tall and constantly standing on their hind legs. Their front paws have mutated into manipulative hands. These have orange fur with slim black stripes.

**Normal Reactions and Attacking:** These guards use their telepathy to tell intruders to leave the area or die. In attacking the Tigeroids enjoy slashing with their claws (3d6/3d6, WC 4) and then in the same combat round they bite with their fangs (20 points of damage, WC 7). Usually these mutants use their telepathy to start talking with strangers. They expect the strangers to peaceably leave their territory.

**Mutations and Defects:** PHYSICAL REFLEC-

TION (LASERS), HEIGHTENED DEXTERITY, HEIGHTENED BALANCE, TELEPATHY, MENTAL DEFENSE SHIELD

These guards use slug ejector pistols that look like toys in their paws (WC 5, 24 points of damage per bullet, 10 shot magazine, IC 7).

Apartments A, B, C, and D always have at least one tigeroid in them. When it gets dark outside both Tigeroids can be expected to be there.

**Apartment A** Tigeroids use extra heavy crossbows for weapons (WC 2, 20 points of damage, IC 2).

**Apartment B** Tigeroids use Gas Pellet weapons (WC 5, 11 intensity paralysis gas, IC 4).

**Apartment C** Tigeroids use huge swords (WC 3, 15 points of damage per strike, IC 1).

**Apartment D** Tigeroids use Paralysis Rods (WC 4, stun the victim, IC 3).

**Mated Pairs of Tigeroids (2)** - AC:4Hit Points:80, 79Movement in Spaces:12Radiation Resistance:10Constitution:18Mental Resistance:11Strength:18Dexterity:18

**Mutations:** Physical Reflection (Lasers), Heightened Dexterity, Heightened Balance, Telepathy, Mental Defense Shield

**Appearance:** These tigeroids are ten feet tall and constantly standing on their hind legs. Their front paws have mutated into manipulative hands. These have orange fur with slim black stripes.

**Normal Reactions and Attacking:** In attacking these tigeroids use the weapons of the apartment in attack and defense. Usually these mutants use their telepathy to start talking with strangers. They expect the strangers to peaceably leave their territory.

---

## LEVEL 37 – TIGEROID KIT HABITAT

---

**As the portal opens, two tigeroids with slug pistols stop you from taking a step onto their level. “Why are you here?” they mentally communicate with you. It looks like they are ready for a fight if one is needed.**

The same conditions of this level are as level 36. Each of these apartments has 7 tigeroid young children in various stages of development. There is a female Tigeroid taking care of each batch of these youths. There always is a pair of guards at the central elevator.

# WARDEN, SILVER HOTEL

## Level 35: Snow Habitat

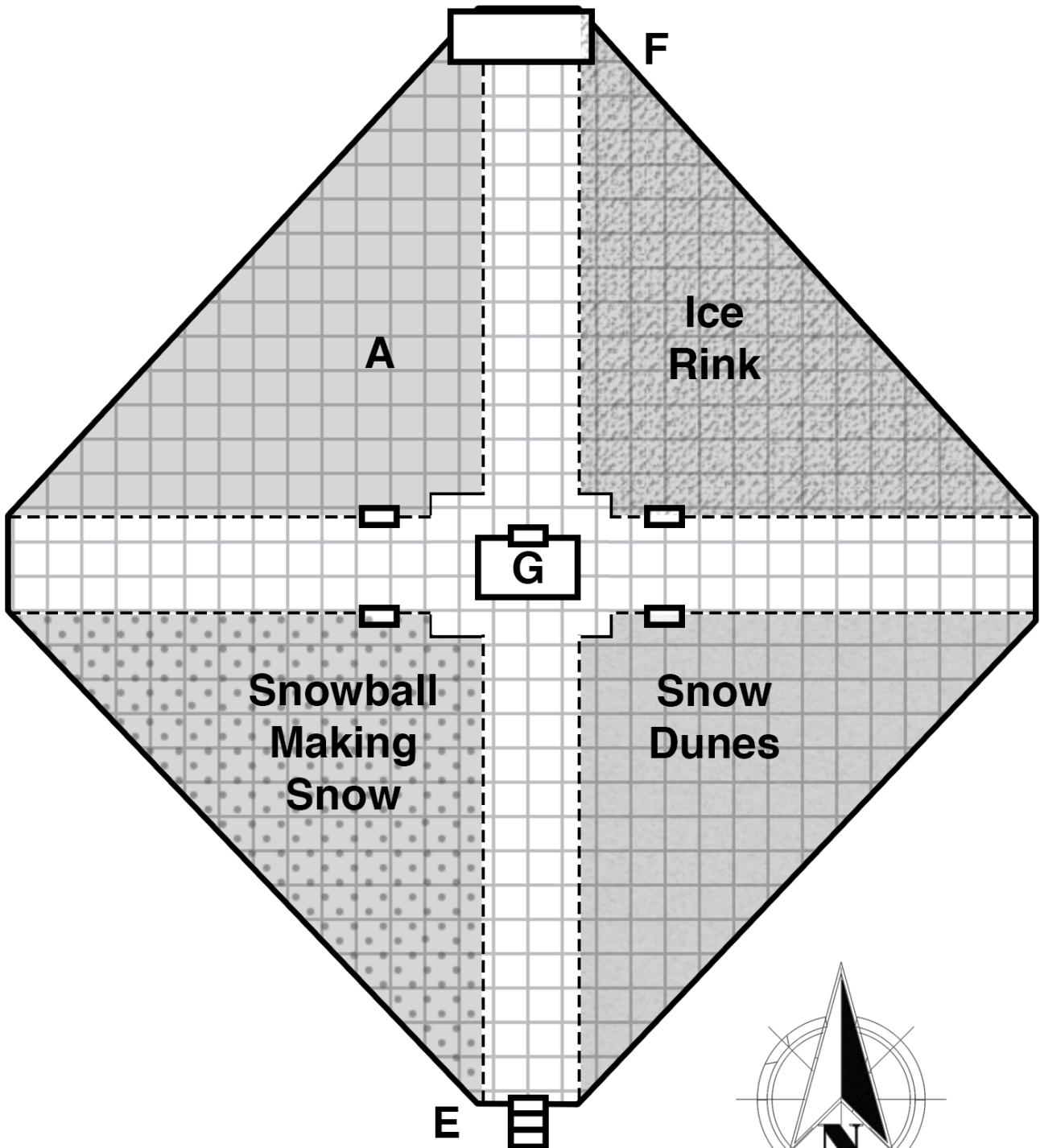

**Female Guardian Tigeroid** - AC: 4, Hit Points: 111, Movement in Spaces: 12, Radiation Resistance: 10, Constitution: 18, Mental Resistance: 11, Strength: 18, Dexterity: 18

**Mutations:** Physical Reflection (Lasers), Heightened Dexterity, Heightened Balance, Telepathy, Mental Defense Shield

**Appearance:** These tigeroids are ten feet tall and constantly standing on their hind legs. Their front paws have mutated into manipulative hands. These have orange fur with slim black stripes.

**Normal Reactions and Attacking:** In attacking the tigeroids enjoy slashing with their claws (3d6/3d6, WC 4) and then in the same combat round they bite with their fangs (20 points of damage, WC 7). Usually these mutants use their telepathy to start talking with strangers. They expect the strangers to peaceably leave their territory. Their slug projector pistols are WC 5; dmg 2d6 subdual.

## **LEVEL 38 – MATURE TIGEROID HABITAT**

**As the portal opens, two tigeroids with protein disruptor pistols stop you from taking a step onto their level. “Why are you here?” they mentally communicate with you. It looks like they are ready for a fight if one is needed.**

This level of tigeroids is filled with mature and older beasts. These mutants are the cream of the tigeroid clan and there is a lot of equipment of all types in their apartments.

**Mature Tigeroid** - AC: 4, Hit Points: 70, Movement in Spaces: 12, Radiation Resistance: 10, Constitution: 18, Mental Resistance: 11, Strength: 18, Dexterity: 18

**Appearance:** These Tigeroids are ten feet tall and constantly standing on their hind legs. Their front paws have mutated into manipulative hands. These have orange fur with slim black stripes. There are 3 of these in each apartment.

**Normal Reactions and Attacking:** In attacking the tigeroids use their energy weapons first and then their claws and fangs if their weapons are ineffective. They wear a duralloy shield and use Protein Disruptor Pistols (WC 8, 30 points of damage when touching flesh, IC 7). Usually these mutants use their telepathy to start talking with strangers. They expect the strangers to peaceably leave their territory. Each of these mutants has a brown color band.

In Apartment C the leader of the clan has a blue color band.

**Mutations and Defects:** PHYSICAL REFLECTION (LASERS), HEIGHTENED DEXTERITY, HEIGHTENED BALANCE, TELEPATHY, MENTAL DEFENSE SHIELD

## **LEVEL 39 – GIANT BEES LEVEL**

**As the portal opens, the way in is blocked by very strange hexagons. Examination shows they are made of thick wax. All of the cells are filled with some type of golden liquid. You will have to cut into them to discover what the substance is. There is a very narrow opening on the left side of the portal that you can squeeze through if you take off all of your equipment and armor.**

The fire escape entrance is blocked open with large chunks of bees wax. Explorers moving up and down this fire escape will be attacked by two hovering giant bees when they near this door.

**Dense Attack Bees** - AC: 8, Hit Points: 99, Movement in Spaces: 6/15 flying, Radiation Resistance: 18, Constitution: 18, Mental Resistance: 18, Strength: 18, Dexterity: 18

**Appearance:** The drone bees are four feet long with a two foot stinger. The queen is ten feet long with razor sharp mandibles.

**Normal Reactions and Attacking:** These bees sting with intensity 15 poison. A successful sting kills the bee as their stinger is pulled out of their body. Their bodies are so dense that slugs and melee weapons of all types only do 5 points of damage per successful strike.

**Mutations:** TALLER, HEIGHTENED TOUCH, HEIGHTENED VISION, HEIGHTENED DEXTERITY, HEIGHTENED BALANCE, MENTAL DEFENSE SHIELD, HEIGHTENED BRAIN TALENT

**1) and F** - There are large hexagonal wax cells from ceiling to floor in front of the freight elevator. These are filled with royal jelly. A three-inch slice of honey can heal five points of damage from any being eating the jelly. If the characters break open two of the cells, three bees come into the freight elevator and attack.

**2) and G** - These are large hexagonal wax cells from ceiling to floor in front of the central elevator. If characters begin destroying those cells three bees come into the elevator and attack.

**3)** - These wax cells have 3-6 helpless bee larvae. If characters begin attacking these cells, four bees come and attack.

# WARDEN, SILVER HOTEL

## Bee Level 39

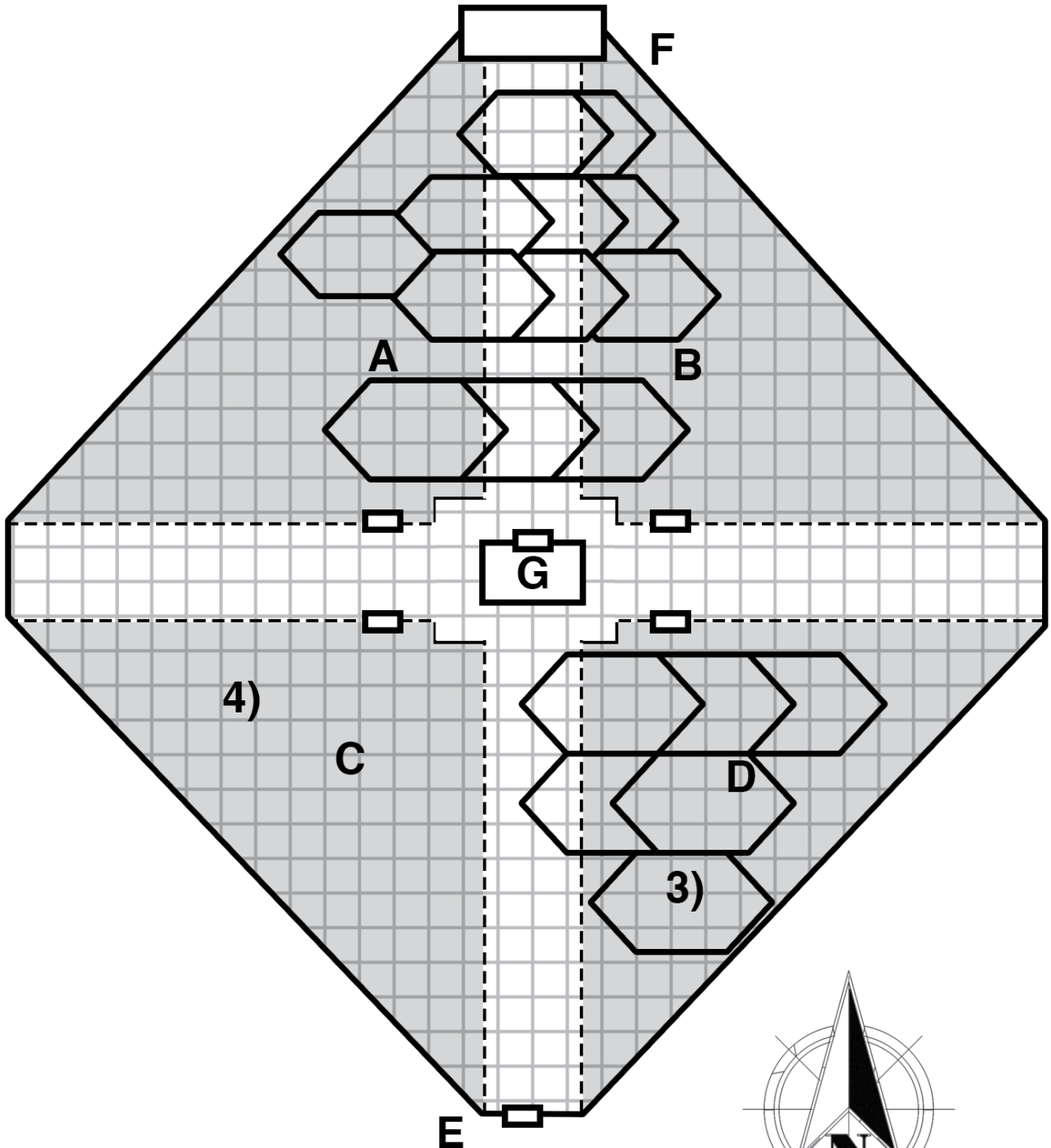

4) - The queen is laying eggs in this area. There are 15 large eggs, 9 large drone bees, and the queen in this area.

**Dense Queen Bee** - AC: 8, Hit Points: 99, Movement in Spaces: 6/15 flying, Radiation Resistance: 18, Constitution: 18, Mental Resistance: 18, Strength: 18, Dexterity: 18

**Mutations:** Taller, Heightened Touch, Heightened Vision, Heightened Dexterity, Heightened Balance, Mental Defense Shield, and Heightened Brain Talent

**Appearance:** This queen bee is ten feet long and six feet tall. She is intelligent and attacks with her helpers to protect the eggs.

**Normal Reactions and Attacking:** The queen bee attacks with her mandibles (WC 6, 20 points of damage per strike).

The furniture from the apartments has been broken and pushed out of the apartments into the central hall.

---

## LEVEL 40 – GRAY ENGINEERING LEVEL

---

**You notice the portal won't open unless you have a gray band.**

This level requires a gray band to enter. It hasn't been entered in over 300 years.

A thick level of dust fills these corridors. The corridors are dark as the lights wore out years ago.

The moment the level is entered, two butler robots attack the characters.

**Butler Robot (2)** - AC: 4, Hit Points: 50, 44, Movement in Spaces: 75, Radiation Resistance: 3, Constitution: 11, Mental Resistance: 10, Strength: 8, Dexterity: 15

**Power System:** 48-hour power pack

**Body Style:** Humanoid

**Motive System:** Legs

**Miscellaneous Systems:** Human normal sensor package, short wave communication package, 1st & 2nd level computer packages, human skills programming package.

**Appearance:** These robots are six feet tall with a humanoid shape. It has a square head with large visual lenses. The unit's hands are articulated and can manipulate things like a human hand can.

**Normal Reaction and Attacking:** These units are insane and attack any moving being. They wield makeshift clubs (WC 2, 15 points of damage, IC 1).

**Apartment A** requires a gold band to enter. The area is large and filled with huge computer screens. There are images of some of the parts of other levels on the screens. The computer screens are voice commanded to operate. There are five computer stations in this apartment.

This apartment is connected to the main hotel computer system. It's quickly apparent from conversing with the A.I. that it is quite insane and wants to kill all humans in the hotel.

**Apartment B** requires a gray band to enter. It's filled with engineering work tables and devices that were being repaired when the radiation cloud passed through.

**Apartment C** requires a gray band to enter. While the work tables appear to be empty they are filled with nano technology that is designed to destroy devices of all types and turn them to dust. These nanos get on the characters that enter the area and destroy all technological devices they touch for 24 hours.

**Apartment D** is an apartment that looks lived in by an engineering family. One of the bedrooms is filled with flight drones and control mods. The other rooms have pictures on the walls of a man and his three sons working on equipment of all types.

---

## LEVEL 41 – GRAY ENGINEERING LEVEL

---

**You notice the portal won't open unless you have a gray band.**

This level hasn't been entered in over 300 years.

All of these apartments were the living quarters for engineers. There is a great deal of useful tools in each of these apartments. Every apartment has a white pile of dust somewhere in the rooms and a gray band in that dust. All of the equipment in the kitchens and family room work properly. Each of the apartments has a functioning engineering robot repairing anything that stops working. The engineering robot challenges any intruders not wearing grey bands.

A thick level of dust fills these corridors. The corridors are dark as the lights wore out years ago.

## LEVEL 42 – GRAY ENGINEERING LEVEL

---

**You notice this portal won't open unless you have a gray band.**

This level hasn't been entered in over 300 years.

All of these rooms were for the repair of robots. Instead of beds, they are filled with work tables and machinery parts of robots. All of these apartments require a gray band to open.

**Apartment A** repaired security robots. In one of the rooms there is a half repaired bot. As the characters step into the chamber they are attacked by the two paralysis tentacles of the half repaired but otherwise immobile and malfunctioning robot (WC 5, 19 feet range, paralyzes for 4 hours at a touch).

**Apartment B** repairs toys of all types. There are lots of repaired small toy robots. There are many fake energy pistols as well as fake helmets that light up and communicate with each other.

**Apartment C** repairs computer motherboards. There are several programs here that could be used to fix the A.I. on the ship by hooking up the repair program to the main computer bank and operating it.

**Apartment D** is a normal engineering apartment for a married pair of engineers. There are two piles of white dust on the master bedroom bed. These have gray bracelets in the piles.

A thick level of dust fills these corridors. The corridors are dark as the lights wore out years ago.

## LEVEL 43 – APARTMENT LEVEL

---

**As the portal opens you notice thick dust on everything. It's clear no one or thing has been here for generations. The lights are not working in the corridor and it's very dark.**

No one has been on this level for 300 years. These apartments were lived in by ordinary families and there isn't much in the way of useful things in each apartment. The lights are burned out in all of these areas.

## LEVEL 44 – RED ANDROID LEVEL

---

**As you enter the level you see two large humanoid coming toward you. They are in black robes. They have large rifles in their hands. You see their**

**hands and faces are bright red. The featureless nature of their faces shows them to be red androids.**

**Red Android** - AC: 3, Hit Points: 100, Movement in Spaces: 12, Radiation Resistance: 18, Constitution: 18, Mental Resistance: 10, Strength: 18, Dexterity: 18

**Appearance:** These red androids are 9 foot tall and usually wear long black robes with a large cowl. All of these bear energy weapons of many types.

**Normal Reactions and Attacking:** The two corridor guards use large bore shotguns (WC 7, 20 points of damage, IC 4).

**Apartment A:** The 3 androids in Apartment A use modified laser rifles (WC 6, 40 points of damage, IC 7). This apartment is filled with large metal plates of armor like the androids were going to barricade and armor up the corridors of apartments.

**Apartment B:** The 4 androids in Apartment B use some type of strange lightning pistol (Weapon Class 4, IC 8, 35 points of damage, 3 shots per hydrogen energy cell). This apartment is filled with energy generating devices as if the androids were going to power up the area to shock intruders.

**Apartment C:** The two androids in Apartment C are using fragmentation grenades (WC 3, 25 points of damage in a 20 feet circle, IC 4). There is a large vat of red gel in the middle of this apartment. The androids use it to repair damaged systems. There are several crystal devices attached to the vat. In the master bedroom are 30 bushels of corn.

**Apartment D:** The three androids are using large flamethrowers (WC 7, 30 flame damage, IC 7.) The apartment has ten large fire extinguishers. There are construction tools and welding torches in this apartment.

## LEVEL 45 – GOO LEVEL

---

**Before you enter this level you note the thick fog of green gas filling the area. You can just barely make out some patches of green goo on the walls and ceiling. You know what is generating the strange fog.**

When the elevators open or the fire escape door is used a blast of noxious green gas flows into the area (poison intensity 6).

The corridor is dark except for the glowing green goo patches on the walls and ceiling. This goo is making a poison spore gas in the corridors (poison intensity 10).



**Apartment A** has red goo on the walls and ceiling. The red goo is a special type of fungus spore. If the characters breathe it in, there is a 1-26% chance that in a week the fungus branches erupt from the arms and legs of the victim. This does 40 points of damage to the victim. They must use special measures to rid themselves of the fungus infestation.

**Apartment B** has orange goo on the walls and ceiling. The goo has an unusual armoring property. The apartment is filled with orange spores creating a dense fog. If the characters breathe in these spores their flesh turns bright orange and their physical armor class increases by 2.

**Apartment C** has a black dust fungus, inches thick, on the apartment floor. It's an intensity 15 contact poison.

**Apartment D** has a red dust fungus over everything. Large clouds of red spores rise up from the floor with every step the characters take into the apartment. The spores coat the bodies of the characters but do nothing to them.

This apartment was used by a pistol collector. There is every type of non military pistol available in the Game Master's campaign hanging on the walls of the rooms of the apartment. None of them are loaded. However, the smallest bedroom has all the supplies from black power and mini-balls to hydrogen energy cells and shotgun shells.

---

## LEVEL 46 – CRYSTAL APARTMENT

---

**The corridor is dark and humid. It feels very warm in the area. The sound of many drips of water can be heard. Lights reveal some type of lichen on the floor. The second you step into the corridor, you all feel a voice in your mind.**

**“Hello, it has been a long time since someone visited me. Be careful of the lichen on the floor, it's a deadly poison (that's a lie). My name is Zahn, what's your name?”**

With this, the party begins a mental conversation with the largest intelligence in the level, a huge fungi brain mutant in Apartment A. It wants to keep the characters out of the area, and will use deception, gifts, or threats to do so.

**Brain Fungi** - AC: 7, Hit Points: 78, Movement in Spaces: 0, Radiation Resistance: 3, Constitution: 17, Mental Resistance: 18, Strength: 3, Dexterity: 3

**Mutations:** Heightened Intelligence, Telepathy, Telekinesis, Force Field Generation, Mental Defense Shield, Heightened Brain Talent, Electrical Generation (4d6 in damage)

**Appearance:** It's a ten-foot tall and long fungus resembling a human brain. There is a sheet of crystal between the brain and the rest of the apartment. Water drips on the brain from the ceiling.

**Normal Reactions:** The brain wants to keep the characters out of its level. It offers each member of the group a small crystal with a chunk of its brain inside in exchange for leaving it and its domain alone. The crystal gives the holder a bonus +2 in all mental attack saves. The brain can use telekinesis to give each of the characters this small crystal for them not coming into the level. The electrical attack can only be made when characters enter Apartment A.

The brain wants to keep secret that it is growing other infant brains in the other apartments of this level. In Apartment B there is dripping water in the bathroom and on the floor covered in crystal is a foot long and tall fungi brain growing and helpless. In Apartment C hidden in a closet is dripping water and a two-inch long and tall brain in crystal growing and helpless. In apartment D hidden in the smallest bedroom is a nine-inch long and tall and helpless brain fungi covered in a crystal while water drips on it from the ceiling.

---

## LEVEL 47 – APARTMENT

---

**The corridor in this area is spotless. The lights are all working in the ceiling. With the first step into the corridor you hear a voice.**

**“Welcome to the Warden Hotel. This is considered the best ultra-modern hotel in Epsilon City. We hope you enjoy your stay here.”**

All of these apartments are cleaned every week by cleaning robots. Everything is immaculate in each apartments.

---

## LEVEL 48 – BLASTED OPEN FLOOR: AIR BLOOD BIRD NESTS

---

**There is a sharp wind blowing throughout this area. You instantly notice that apartments have been blasted open to the outside air. One can also notice two large nests with a huge bird sticking its head out of each nest.**

# WARDEN, SILVER HOTEL

## Level 48

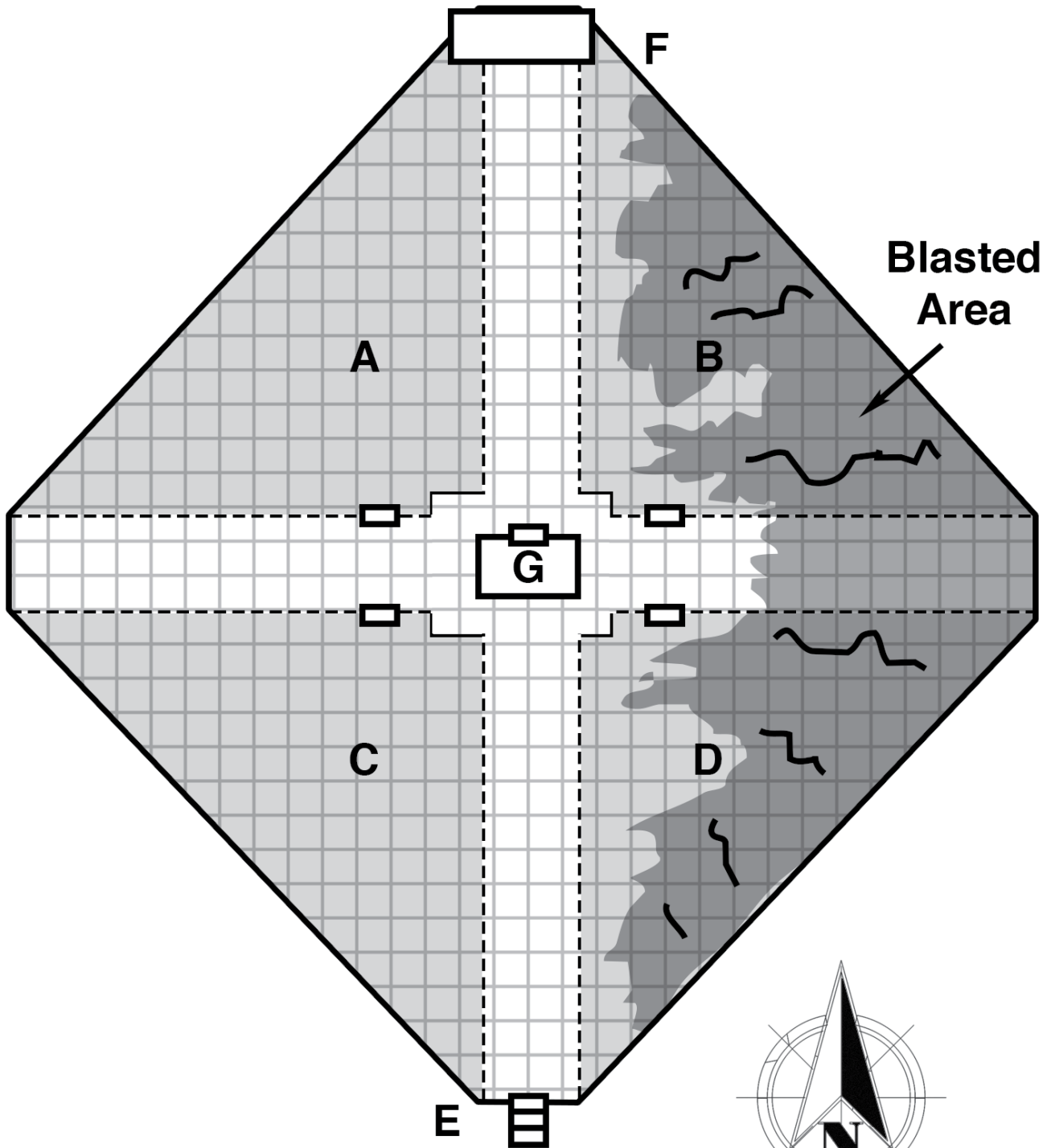

There are two blood bird nests on this floor in the blasted areas of the level.

Each nest has three blood red eggs the size of a man's head. They are being protected by a male and female blood bird.

**Blood Bird (2)** - AC: 4, Hit Points: 49, Movement in Spaces: 12/ 24 flying, Radiation Resistance: 18, Constitution: 11, Mental Resistance: 3, Strength: 9, Dexterity: 18

**Mutations:** Radiated Eyes Intensity 10, immune to all mental attacks

**Appearance:** This is a four feet tall aggressive mutated scarlet tanager.

**Normal Reactions and Attacking:** As intruders come onto the level, there are four birds physically attacking the intruders. When they get below half of their hit points they begin attacking with their radiated eyes mutation.

The birds have been living here for many years. They've killed a lot of visitors over the years: there are twenty skeletons around the apartments and give off intensity 5 radiation. There are several laser rifles and laser pistols and these are also covered in intensity 5 radiation as well.

There are four large eggs in each nest. These chicks can be raised and tamed by people if they are given a great deal of meat in their formative years.

---

## LEVEL 49 – IMITATOR NESTS

---

**As you enter this area you see a huge blasted area open to the air. There are two large nests in this area. As you go closer to the nests two beings that look just like you greet you and ask why you are there. Each of these beings has a huge energy rifle of some type pointed your way.**

**Imitator (Golden Hawk)** - AC: 7, Hit Points: 22, Movement in Spaces: 10/20 when flying, Radiation Resistance: 18, Constitution: 12, Mental Resistance: 18, Strength: 11, Dexterity: 18

**Mutations:** Shape-change: when changed it is totally resistant to the mutational powers of the creature it is imitating, while in bird form its feathers are immune to laser shots.

**Appearance:** In normal mode the mutant is 9 feet tall with golden wings and the hawk beak for its breed. When the characters first see the creature it resembles one of them.

**Normal Reactions and Attacking:** The Imitator has shape changed into looking like one of the characters and now is immune to any mutations that character might have. The rifles are a bluff and have no real ability to do damage. If forced into a melee the Imitator changes back into its bird form. It can claw (WC 4, 4d6 in damage), it stabs with its beak (WC 5, 15 points of damage), and it wing buffets (WC 3, 5d6 in damage).

There are two eggs in each nest. These can be hatched and the mutant birds can be trained to follow the characters. There are many skeletons of mutants in the area and their bones have been picked clean by the mutant birds. All of their equipment has been tossed over the wall. Down on the ground level there is a great deal of smashed equipment. (See 'Why Would They Come to This Place?' on p.177 for details on the bands the birds leave on the fallen bodies).

---

## LEVEL 50 – WORM APARTMENTS

---

**There is a blasted area open to the air. When the characters come on to this area a huge mutated worm creature attacks.**

**[[Insert: Map: MA Sliver Hotel\_Level50]]**

**Mirror Creature Worm** - AC: 3, Hit Points: 99, Movement in Spaces: 8, Radiation Resistance: 18, Constitution: 17, Mental Resistance: 16, Strength: 18, Dexterity: 11

**Mutations:** All energy attacks rebound off of the worm and strike back at the caster of the energy. The force of those reflected attacks are magnified four times. The worm is resistant to all forms of mental attacks.

**Appearance:** The creature is 20 feet long and four feet thick. It's iridescent black in color and leaves slime trails everywhere.

**Normal Reactions and Attacking:** It sees any moving object as a potential meal. It slaps its body at prey (WC 2, 19 points of damage). It keeps attacking a single target until that prey stops moving. It won't go out of the level to chase down characters.

There is a lot of ruined debris in the area. All of this is covered with a thick worm-slime. Apartment C is open and filled with worm offal. Apartment D is open and has 3 much smaller worms (which aren't aggressive) eating off of two large wolfoid bodies.

# WARDEN, SLIVER HOTEL

## Level 49

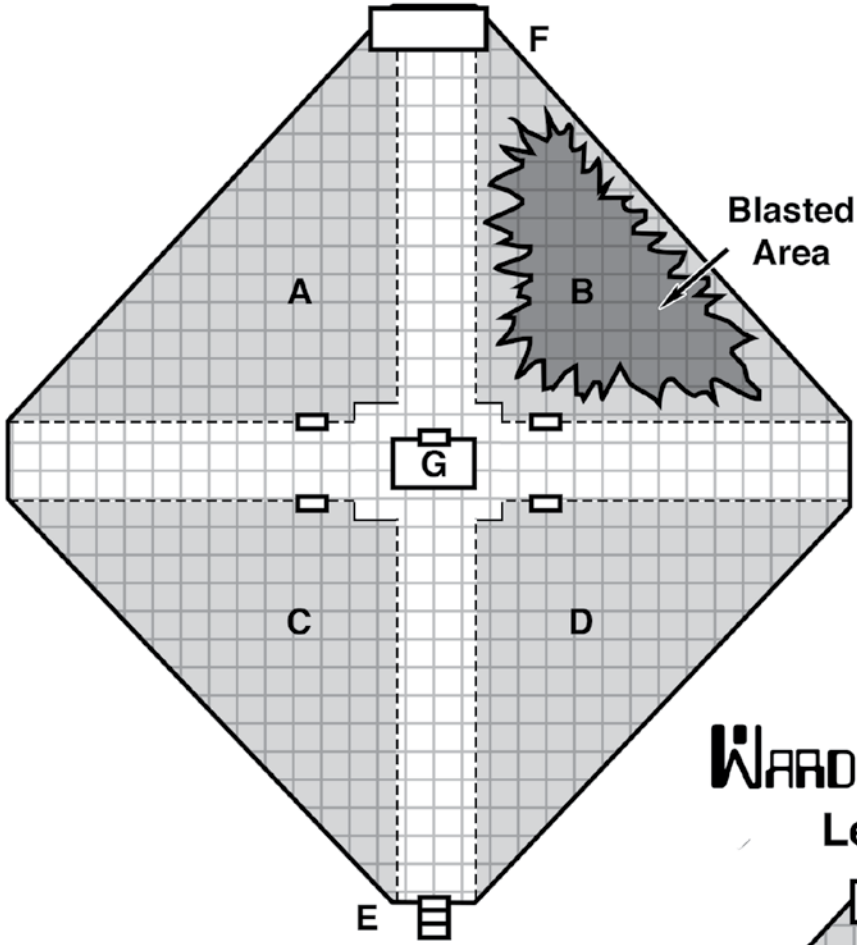

# WARDEN, SLIVER HOTEL

## Level 50

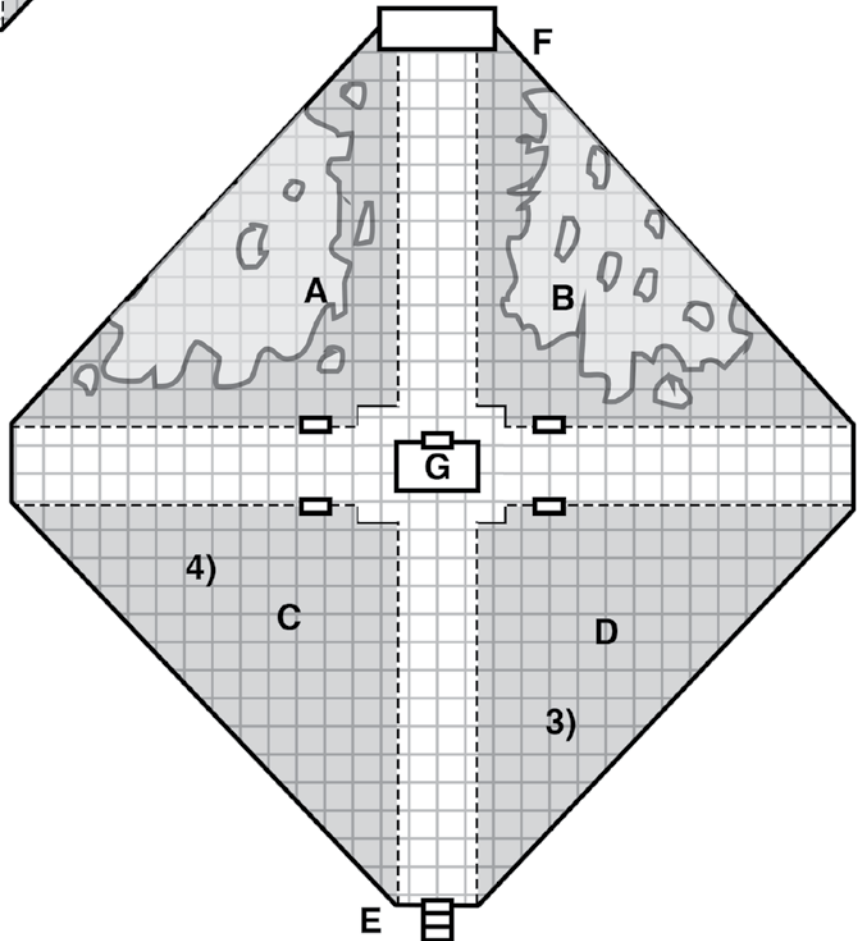

# OLYMPUS SPORTS & ENTERTAINMENT COMPLEX

BY MICHAEL CURTIS

The Olympus Sports & Entertainment Complex is a triumph of athletic and entertainment engineering, a temple to the ancient pursuit of physical perfection, vicarious violence, and the indulgence of the senses. Even before the *Warden* departed the Trans-Plutonian Spacelyards, the Olympus Sports & Entertainment Complex developed a reputation for being the premiere center for leisure activities and athletic competition in the solar system. Now, centuries after the *Warden* embarked on its journey, its stadiums and venues are no less impressive, but for far different reasons.

Today, the Olympus Complex is a veritable fortress, standing resolute against the wolfoids, mutants, and other barbarians of Epsilon City. Olympus' central A.I. has pulled out all the stops to ensure the city's ram-paging mutants are kept out and its staged events and pleasures continue uninterrupted. The result is a stronghold amidst the terrors of Epsilon City filled with wonders from the pre-catastrophe era. This treasure trove continues to entice explorers to enter Olympus and the rare survivor who emerges with hard-won treasures and tales of the bizarre happenings inside the Complex inspires others to risk life and limb.

The Olympus Complex is a sprawling site, one that is far beyond the author's ability to fully detail in the space allowed. Referees seeking to stage adventures set inside the Sports & Entertainment Complex are urged to further flesh out the location, using the provided encounters as inspiration. Although this requires additional work on the part of the referee, the benefit is that each Olympus Complex will be filled with surprises for the players—even if they cheated and read this book!

## DESCRIPTION

The arena designers looked to the stars for inspiration when drafting the Sports & Entertainment Complex. They wanted the greatest athletic stadium in the

solar system to resemble the starry constellations of the ancient Greeks, eternal memorials to the heroes of legend. As a result, the Olympus Complex is a series of interconnected arenas and auxiliary buildings resembling a star cluster when view from above.

The stadium complex stands on the western edge of Epsilon City's central lake. Wide, well-maintained lawns filled with decorative landscaping and statuary depicting the mythic gods and athletic heroes of Earth surround the Complex, conjuring up visions of a heavenly abode where only the worthy may tread. This intended illusion is compromised by the tangled thickets of wild vegetation that occasionally mar the sculpted lawns, signs that all is not perfect in Olympus.

The buildings of Olympus are constructed of a synthetic marble that gleams white and rose in the artificial sunlight and bears omnipresent Art Deco designs of superimposed, abstract, geometric shapes. Several of the buildings are stacked one atop the other and connected by elevator towers, presenting the appearance of a ladder ascending to the heavens. A central building serves as the main entrance to the complex and houses myriad subsidiary venues and services such as presentation halls, restaurants, shops, and similar enclosures.

---

## INHABITANTS OF OLYMPUS

---

Olympus is home to many unique entities, most of which are relics from the pre-catastrophe days of the *Warden*. They are presented here in order of importance within the Complex's hierarchy.

---

### ZEUS, OLYMPUS' A.I.

---

Like many facilities on the *Warden*, the Olympus Sports Complex was provided with an artificial intelligence to maintain the complex, coordinate its activities, and provide entertainment to the visiting sports fans. This A.I. was unsurprisingly given the sobriquet of "Zeus," as it was the undisputed king of Olympus.

Zeus, unlike many – nearly all – other A.I.s aboard the ship, survived the catastrophe with its logic circuits intact and still behaves in a rational manner. If anything, the A.I. has become even more dedicated to its primary programming: keep the Sports Complex running!

To uphold this utmost priority, Zeus has transformed the Complex into a well-defended fortress.

Years ago, when the wolfoid tribes began claiming Epsilon City for their own, several armed bands attempted to raid Olympus and Zeus only turned them back by a thin margin of victory. Determined to prevent this from happening again, Zeus has permanently allocated certain of the Complex's resources—largely its android, bot, and ABE unit staff—to the defense of Olympus. These guardians keep interlopers from stripping the Complex of its storehouses of artifacts and interfering with the eternal schedule of games staged here for empty stadiums.

Zeus has also usurped control over various formerly autonomous Olympus and City systems and turned them into defensive measures. The A.I. controls nearly all the camera drones and security cameras in the complex, giving it almost omniscient knowledge of what happens inside its walls. Additionally (and more dangerously), Zeus has transformed a former entertainment technology, the “Immersive Entertainment Experience,” into an offensive weapon against intruders (see below).

The god-like A.I. can even manifest itself and interact directly against invaders. Thanks to numerous holographic projectors built into the buildings of the Complex, Zeus can manifest as a “solid light” hologram, a light-based physical body created by rapidly moving molecules within the light field.

**Zeus, Olympus A.I. (solid light hologram form) -** AC: 6, Hit Points: 30, Movement in Spaces: 100 Radiation Resistance: n/a, Constitution: n/a, Mental Resistance: 18, Strength: 12, Dexterity: 18

**Appearance:** When in solid light holographic form, Zeus appears as a classic rendition of the Greek god: white robes, flowing beard, laurel wreath, and, most importantly, a crackling lightning bolt in hand.

**Normal Reaction and Attacking:** Zeus seldom manifests, but if the Complex's normal guardians are having difficulties dealing with intruders or simply aren't available, the A.I. arrives with a crack of simu-

lated thunder echoing through Olympus' PA system. If there are any canine-base mutant animals in the party, Zeus assumes the PCs are aligned with the wolfoids and attacks with its lightning bolts. If the PCs are predominantly true human or human-seeking mutant humanoids, however, he interrogates them, seeking to see if they've come to “dwell in Olympus” (see below for more on this process) and reacts accordingly.

#### **Mutations or Defects:**

**ELECTRICAL GENERATION:** Zeus' hologram form can hurl an electrical blast that resembles a lightning bolt up to 200' away. This attack strikes a single target automatically and inflicts 4d6 damage. It produces one blast per round.

## **ZEUS AND OUTSIDERS**

---

As noted above, the A.I.'s primary goal is to keep Olympus intact and the games running. It sees the wolfoids are the largest threat to its main programming and treats wolfoids and other canine mutants with extreme prejudice, targeting them for extermination the minute they set foot inside Olympus.

Not all intruders merit such a harsh response, however. At its core, Zeus was programmed to provide for and entertain the human colonists of the *Warden* and it still pursues these goals. True human or human-looking mutant humanoids are received as potential spectators by the A.I., guests in need of entertainment that would allow Zeus to meet its other programming criteria of hosting games for the recreational benefit of the *Warden's* occupants.

These types of creatures are met by the A.I. in its manifested solid light form and the “god” inquires if they've come to “dwell in the paradise of Olympus.” If they respond in the affirmative, they've sealed their fate. Zeus treats them as honored guests, providing them with android or bot escorts to “protect them” from any dangers and to guide them to the stadiums where they'll be treated to endless sports matches and other forms of athletic entertainment. All their nutritional and clothing needs are provided for and they're safe from the worst the *Warden* has to offer.

*But they can never, ever leave Olympus.*

If the PCs attempt to leave, Zeus simply doesn't allow them to. The A.I. argues that it's pointless to leave when all their needs are provided in Olympus and that they themselves agreed to dwell in paradise. Potential

escapees face a gauntlet of android guardians, IEE projectors, and an angry A.I. between them and freedom. The guards will use non-lethal methods against them, but if it seems likely the honored guests will make it to freedom, this stipulation might be lifted. Better the guest die quickly inside Olympus than horrifically in the streets of Epsilon City, Zeus reasons.

---

## ANDROIDS

---

Given the number of sporting events and entertainment options inside Olympus, it's surprising that there aren't more androids present. These forms of artificial life have a long pedigree of serving as human substitutes when menial or dangerous tasks need doing. In Olympus, however, those roles are largely regulated to the ABE units (see below).

The androids that are found in Olympus fall into two categories: coaches and advanced athletes. Coach androids served as managers and instructors for the ABE unit athletes, providing guidance and leadership to the single-minded artificial life forms. Coach androids take their roles very seriously and keep careful track of their team members condition, skill sets, and, most importantly, win/loss ratios. Coach androids are rarely found without a cadre of 2d4 ABE units nearby.

Athlete androids are highly-skilled competitors used in sports competitions that required more athletic prowess than can be programmed into an ABE unit. Android athletes were especially popular in combative sports events such as wrestling, mixed martial arts, etc. This makes them highly dangerous in combat, much to the dismay of intruders seeking to plunder the Complex. Most of the athlete androids in Olympus are being utilized as guards by Zeus, tasked with dealing with invaders, but they occasionally turn up in staged athletic events as the A.I. desires.

### EXAMPLE ANDROIDS

**Android Gladiator** - AC: 4, Hit Points: 70 each, Movement in Spaces: 6, Radiation Resistance: 18, Constitution: 17, Mental Resistance: 14, Strength: 17, Dexterity: 16

**Appearance:** This android bears the scars of many battles, its synthetic flesh damaged and its faceless visage marred by abrasions. This type of android is usually dressed in a uniform specific to its designated sport (a karate gi, wrestling tights, boxing shorts, etc.), an Olympus Complex coverall, or a mix-mash of improvised armor.

**Normal Reaction and Attacking:** This android model was used in combat sports where and when ABE units lacked the finesse to put on a good show. It was regularly pitted against highly trained human opponents and still harbors a grudge against true humans and human-looking mutated humanoids. This model is well-trained in the combat arts, possessing skills equivalent to certain mutations (see below). It usually fights barehanded (WC 2, dmg 4d6) with a +4 to hit. Rarely, improvised weapons such as sports equipment are employed. These improvised weapons are WC 3 (+4 to hit) and inflict 1d8+3d6 damage on a successful hit.

### Mutations or Defects:

**HEIGHTENED PRECISION:** The android can pinpoint weak points in an opponent's defenses, allowing it to deliver devastating blows. All successful attacks by the android add 2 additional damage dice.

**GENIUS (MILITARY):** The android's training in the combat arts grants it a +4 bonus to all attack rolls and adds an additional damage die to its attacks. This additional die is cumulative to the ones from its *heightened precision* mutation.

**Android Coach AC:** 6, Hit Points: 50, Movement in Spaces: 6, Radiation Resistance: 18, Constitution: 14, Mental Resistance: 16, Strength: 14, Dexterity: 14

**Appearance:** This android appears as a faceless true human. It wears either a sweat suit bearing its team's logo or a natty business suit. A whistle on a cord hangs from around its neck.

**Normal Reaction and Attacking:** Android coaches are programmed to guide their teams to victory and many take this programming too far, caring only for a spotless record. Some will cheat to win, while others arrange accidents to happen to promising opponents. In extreme measures, the android can attack with its fists (WC 2, 2d10 dmg), usually while shouting nonsensical phrases (insert your favorite sports chants here).

### Mutations or Defects:

None

---

## ABES

---

The Olympus Complex was designed to serve two purposes: to provide a place for the colonists to engage in recreational sports activities and to observe and enjoy the same. Knowing that not every colonist would want to participate in sporting events, being content to simply observe and cheer on their favorite team, the designers of Olympus determined that the stadium should

house several competing sports teams of various types. The problem was how to populate these teams in numbers that would be easily—and more importantly, cheaply—managed by the stadium’s central computer. Androids would solve part of this conundrum, but given the high likelihood of physical damage suffered in sports activities, the cost in time and material to maintain all-android teams was considered prohibitive. The designers turned to the cutting edge of biological technology for answers.

For years science had been looking for a means to provide cheap, simple labor to outlying settlements across the solar system. Robots served this need well, but not every community or company could afford them. A low cost, disposable solution was needed. A year before the Warden departed, the solution was discovered: Artificial Biological Entities, or ABEs for short.

ABEs, as their name suggests, are biological machines created from synthetic flesh and bone and powered by a rudimentary nervous and cerebral system. A single, pre-programmed computer chip is inserted into an ABE’s cerebral unit, providing the organic machine with the skills required to fulfil a specialized task. When an ABE wears out, it can be recycled with 98% efficiency and reformed into a new unit. ABEs in many respects are similar to the “crash test dummies” of Earth’s past, designed to resemble humans, suffer a great deal of damage, and be replaced when worn out.

ABEs were originally intended to perform physical labor, but Olympus’ designers saw the ideal solution for their athlete problem. ABEs proved themselves in initial testing and the designers included a special ABE processing and recycling plant within the stadium. Now, the central computer manufactures ABEs as needed, filling the ranks and replacing damaged units in its constant athletic games.

The fashioning and recycling process has run into problems since the catastrophe, however. More and more often, ABE units with inherent problems are being produced. Some have even gone “feral,” dwelling in forgotten corners of the Complex and developing odd belief structures based on some primitive artificial instinct. Zeus deals with the problem as best it can, imprisoning defective ABE units in a massive gulag (see below) in hopes it can repair the recycling process and use the defective models as raw materials, but not all are captured by the A.I.’s minions.

Standard ABEs are equivalent to athletic humans in physical prowess, but lack vocal units and are unnervingly silent. ABE units can be upgraded with increased physical skill and a rudimentary speech modulator to create “star athletes,” but these are uncommon.

**Artificial Biological Entity (ABE)** - AC: 8 (uniform) or 5 (protective padding), Movement in Spaces: 6, Hit Points: 60 each, Radiation Resistance: 11, Constitution: 16, Mental Resistance: 18, Strength: 16, Dexterity: 16

**Appearance:** ABEs resemble true humans from a distance, but up close it is obvious they are artificial life forms. Their skin has a rubbery appearance and usually bears scuff marks, tears, and abrasions suffered in their ongoing athletic contests. Only freshly minted ABEs are free of such damage. The eyes of an ABE are glassy and lifeless, like that of a porcelain doll.

**Normal Reaction and Attacking:** ABEs act based on their cerebral chips’ programming so most are only at their operational best when engaged in the athletic contest they’ve been programmed for. If they encounter the PCs on the playing field, they consider them opponents and react accordingly. Depending on the game being played, this could result in grievous bodily harm to the characters! Off the playing field, ABEs require instruction from either an android coach or the Olympus Complex’s central computer to react to situations outside of their programming. Barring this instruction, an ABE will return to its locker room until its next game. ABEs are generally either armed with sports equipment (WC 3; 1d8/1d6/1d6 damage) or unarmed (WC 1; 1d4/1d3/1d4 damage), but some have more lethal weaponry of the computer’s choosing.

**Mutations or Defects:**

**POISON IMMUNITY:** Due to their artificial nature, ABEs are unaffected by poison of any type.

**PHYSICAL REFLECTION (PARALYSIS DART, SLUG PROJECTORS):** The hard, rubbery flesh of ABEs resist paralysis darts and the rubber bullets of slug projectors, reflecting them randomly away if struck by such projectiles.



## CUSTOMIZED ABE TEAMS

---

The referee is encouraged to create and customize a wide variety of ABE sports teams to populate Olympus. The following is just one example of what an ABE team in the Olympus Complex might look like.

### THE WARDEN HELL WIDOWS

Sometimes something goes wrong when ABE units are recycled. A glitch develops in the casting process, a cerebral chip becomes corrupted, or biological components become diseased, all of which leads to ABE breakdown. When this affects an entire batch, the results can be deadly.

The Warden Hell Widows were originally a roller derby team, a squad of five ABEs that entertained the fans with a mixture of adept roller skating and physical violence. Unfortunately, sometime after the catastrophe, this ABE software batch became compromised and ABEs installed with the chips are now a hazard of the Olympus Sports Complex. The Warden Hell Widows roll through the corridors of the complex, assaulting any they encounter with brutal beatings and combat-level technique roller skating.

The Warden Hell Widows can never be truly defeated short of destroying the ABE foundry. If slain, the central computer manufactures replacement Hell Widows that resume their old activities.

**ABEs: Warden Hell Widows (5)** - AC: 1, Hit Points: 60 each, Movement in Spaces: 10, Radiation Resistance: 11, Constitution: 16, Mental Resistance: 18, Strength: 16, Dexterity: 16

**Appearance:** The Warden Hell Widows are always encountered in a group of five. They resemble physically attractive and fit females of various genetic backgrounds dressed in uniforms consisting of shorts, tights, scoop-necked shirts adorned with a logo depicting a veiled female dressed in black and holding a pitchfork, helmet, elbow and knee pads, and roller skates. Sometimes they carry makeshift weapons such as hockey or lacrosse sticks and occasionally more lethal weapons scavenged from their victims.

**Normal Reaction and Attacking:** The Hell Widows prowl the corridors of the complex looking for prey. Their approach is heralded by the sound of rolling wheels echoing down the halls, a sound that speeds up in tempo when they sight their targets. The Warden Hell Widows attack with a mixture of punches, kicks,

and weaponry, using their speed and agility to avoid attacks. If their opponents put up a good fight, there is a 50% chance the Hell Widows seek to knockout rather than kill their foes, hoping to fight them again at a later date. The Hell Widows are 50% likely to be unarmed (WC 1; 1d4/1d3/1d4 damage), 25% likely to carry makeshift weapons (WC 3; 1d8/1d6/1d6 damage), and 25% likely to carry more formidable weaponry of the referee's choosing.

#### **Mutations or Defects:**

**HEIGHTENED DEXTERITY:** The Hell Widows have an almost uncanny agility when on their skates, granting them an AC of 1. Should they ever be parted with their skates, their AC is reduced to 5.

**POISON IMMUNITY:** Due to their artificial nature, ABEs are unaffected by poison of any type.

**PHYSICAL REFLECTION (PARALYSIS DART, SLUG PROJECTORS):** The hard, rubbery flesh of ABEs resist paralysis darts and the rubber bullets of slug projectors, reflecting them randomly away if struck by such projectiles.

## IMMERSIVE ENTERTAINMENT EXPERIENCE

---

Immersive Entertainment was the cutting edge of human recreation when the *Warden* departed on its long journey. While animatronic and android-staffed theme parks and pleasure palaces had a long history in human entertainment, the Immersive Entertainment Experience (or IEE for short) was a brand new means of escapism, one that placed the user into a seemingly 100% realistic environment without the need for clumsy virtual reality relays or animated staff.

IEE technology worked directly with the user's own mind and senses to create an absolutely real hallucination. A person undergoing an IEE reacts as if all he or she experiences in this technologically-induced hallucination is utterly real. He tastes food and feels fulfilled by it, smells aromas, experiences aches and pains, and revels in physical pleasures. IEE technology employed special mental and physiological blockers that prevented the user from becoming addicted to these artificial experiences and was considered so safe that even children could enjoy an IEE without development harm, although psychological screening was still required before undergoing an IEE for the first time.

## IEE TECHNOLOGY AND INTRUDERS

Prior to the catastrophe, IEE technology had built-in safe guards that would kick in if the user's emotional or physical state exceeded set perimeters, dropping the user back safely into the real world with no hazardous repercussions. In the wake of the catastrophe, however, the various IEE technology in the Olympus Complex is no longer working with 100% efficiency. Zeus has linked the complex's IEE emitters with itself and is capable of throwing invaders from outside directly into a realistic hallucination, one capable of killing the individual if they're not careful.

When Zeus triggers an IEE effect inside the Olympus Complex, treat it as a mental attack from a creature with a Mental Resistance of 12. Beings affected by the IEE receive a shared hallucination picked by Zeus from the Complex's vast database of Immersive Entertainment programming. The referee can use one of the IEE scenarios described in the Appendix below or use new ones of his own devising.

### RANDOM ENCOUNTERS

The referee should check for wandering creatures every hour the PCs remain inside the complex as normal. An encounter happens on a roll of 1 in 6 in most areas. If an encounter occurs, roll 1d20 on the table below to determine the type of creature encountered.

**TABLE 9-1: SPORTS COMPLEX  
RANDOM ENCOUNTER TABLE**

| D20 | ENCOUNTER   |
|-----|---|
| 1   | IEE Event (see above and Appendix)  |
| 2   | IEE Event (see above and Appendix)  |
| 3   | 2d4 Feral ABE Units (see area 1-6)  |
| 4   | 2d4 Feral ABE Units (see area 1-6)  |
| 5   | 1 Security Bot (see area 4-2)   |
| 6   | 1 Security Bot (see area 4-2)   |
| 7   | 1d4 Android Guards (see area 1-5)   |
| 8   | 1d6+1 Android Guards (see area 1-5)   |
| 9   | 2d4 Android Guards (see area 1-5)   |
| 10  | Sports Team of 2d4 ABE Units and 1 Android Coach (see above)                      |
| 11  | Sports Team of 2d4 ABE Units and 1 Android Coach (see above)                      |
| 12  | Warden Hell Widows (see above) or other customized team of the referee's devising |

|    |  |
|----|--|
| 13 | 2 Slaybots (see Area 4-5)                            |
| 14 | 1d4 Mad Playbots (see area 3A below)                 |
| 15 | 2d4 wolfoids (determine tribe randomly)              |
| 16 | 2d4 Uhways Hunter-Scavengers (see area 3C-2)         |
| 17 | 1 Standard General Purpose Robot (see MA p.7)        |
| 18 | 1d3 Many-Jawed Creeper Vines (see M.A. Deluxe p. 63) |
| 19 | 1 Stalker Plant (see M.A. Deluxe p, 63)              |
| 20 | Zeus in Solid Light Hologram Form (see above)        |

## AREA 1: THE ENTRANCE HUB

The Olympus Complex architects intended the sports and entertainment facility to be a place entire families could visit together and find enjoyment, regardless of their personal tastes. They realized that not all the colonists would be sports fans and included many alternatives to capture their interest. While one spouse might be whiling away the time watching a bashball game, the other could indulge in shopping, dining, or visiting various entertainment venues. Most of these establishments and services were contained in the Complex's Entrance Hub.

The Entrance Hub is a massive space laid out underneath a transparent domed ceiling of high density, transparent acrylic. During the day, the building is lit by the ship's "sunlight" cycle, while lighting panels suspended from a grid-like network of supports illuminate the interior at night. The ceiling soars to nearly 100' high, accommodating the taller rides in the hub's amusement area. Entrance to the hub is achieved by a long expanse of automatic doors situated in the Complex's south face.

The shops and services inside are housed in adjacent stores and kiosks designed to resemble small town storefronts, giving the space a homey atmosphere. Decorative plant beds help guide foot traffic and lend a touch of nature to the indoor space. These planted areas range from the well-maintained to the overgrown to containing dead vegetation (or even mutant threats if the referee desires). The Hub is in relatively good condition, but signs of neglect and poor maintenance are evident in places.

## GENERAL AREAS

---

The following areas are present in the Entrance Hub but are left to the referee to develop as required.

**Auditoriums:** Two massive auditoriums with maximum occupancies in the thousands flank the office area of the hub. These spaces have an array of holographic and tri-d projectors, public address systems, computer link terminals, and other features designed to augment presentations.

**Businesses:** There are almost 200 shops, dining establishments, entertainment venues, and other services in the Entrance Hub. Some are in pristine condition while others are looted ruins. It is up to the referee to determine what each business catered to and whether or not it is currently occupied. A random table is provided to help the referee determine what a location housed or to spark his own creativity in determining the business's function.

**Food Courts:** Two plazas served as massive food courts filled with an abundance of dining kiosks and open air seating. Decorative vegetation, ornamental fountains, and holographic advertisements are present in these places. Feral ABEs or mutants that have so far escaped the notice of the android guards might lair here with accumulated treasures.

**Offices:** This maze of offices and cubicles was staffed by human and android workers prior to the catastrophe. The daily functions of the hub were attended to in this section. It is now a darkened maze, haunted by feral ABE units. PCs wishing to explore the area have a 1 in 6 chance of discovering something worthwhile each hour they search. Roll 1d10 to determine what they find: 1) brown color band; 2) gray color band; 3) chemical flammable retardant; 4) sound elimination head phones; 5) portable energy lamp; 6) 1d4 hydrogen cells; 7) first aid kit; 8) backpack; 9) universal food paste; 10) two way radio headset units (1 pair). Resolve random encounters as normal.

### AREA 1-1—COMPLEX LOBBY

---

**A tremendous, airy space greets you just beyond the doors. The walls are adorned with giant images of sports figures in mid-action, team logos, and advertisements for many of the complex's attractions. An indoor garden is overgrown, throwing tendrils of green across the polished marble floor. Shining**

**bits of silvery metal is visible amongst the greenery. Dark storefronts face the broad plaza; some show signs of vandalism and destruction, while others appear largely intact.**

The entrance of the building is a perpetual battlefield between the complex's inhabitants and intruders from the city. Although it seems placid, that's due to the custodial bots clearing away the bodies the plants here do not consume.

**Spear Trees (6)** - AC: 8 (vines AC 7), Hit Points: 55 each, Movement in Spaces: n/a, Radiation Resistance: 12, Constitution: 14, Mental Resistance: 10, Strength: 13, Dexterity: 6

**Appearance:** A spear tree resembles an ornamental dwarf pine. It appears similar to its unaltered cousin, but possesses several branches lacking needles and a serpent's nest of tangled vines growing from its base. These leafy tendrils pour out of the garden's former decorative edges, spilling onto the floor in a 50' radius. Every now and again, attentive observers notice a shudder reverberate through the plant.

**Normal Reaction and Attacking:** Each plant is 75% likely to attack any warm-blooded creature entering the lobby. If it fails to act, it is satiated with a recent meal and in a dormant, digestive state. If it is not, it attempts to kill prey moving within reach of its vines then drag the prey into its maw.

#### **Mutations or Defects:**

**INCREASED SENSES (INFRA-RED):** The mutant detects heat energy in a 75' radius, allowing them to target warm-blooded creatures and see in darkness. Its sensory organs are located at the tip of the tree.

**FANGS:** The plant has toothy jaws at the base of its trunk allowing them to consume victims. This bite is WC 3 and inflicts 2d6+2 damage.





**SPEAR LIMBS:** The mutant has 2d10 branches it can fire like spears at a range of up to 180' feet. Each of these branches is tipped with a needle-sharp seed pod that beaks off when contacting protein material. The spear branch is WC 2 and the seed pod inflicts 3d6 damage. If a victim is slain by the seeds, they use the dead flesh as fertilizer and sprout in 1d4 days.

**SQUEEZE VINES:** These 50' long vines grab as WC 2, grappling prey and constricting them for 4 dice of damage. Each vine is AC 7 and has 25 hit points. Only severing a vine will free a victim. The vines can drag captured prey towards the plant's mouth at a rate of 25' per round.

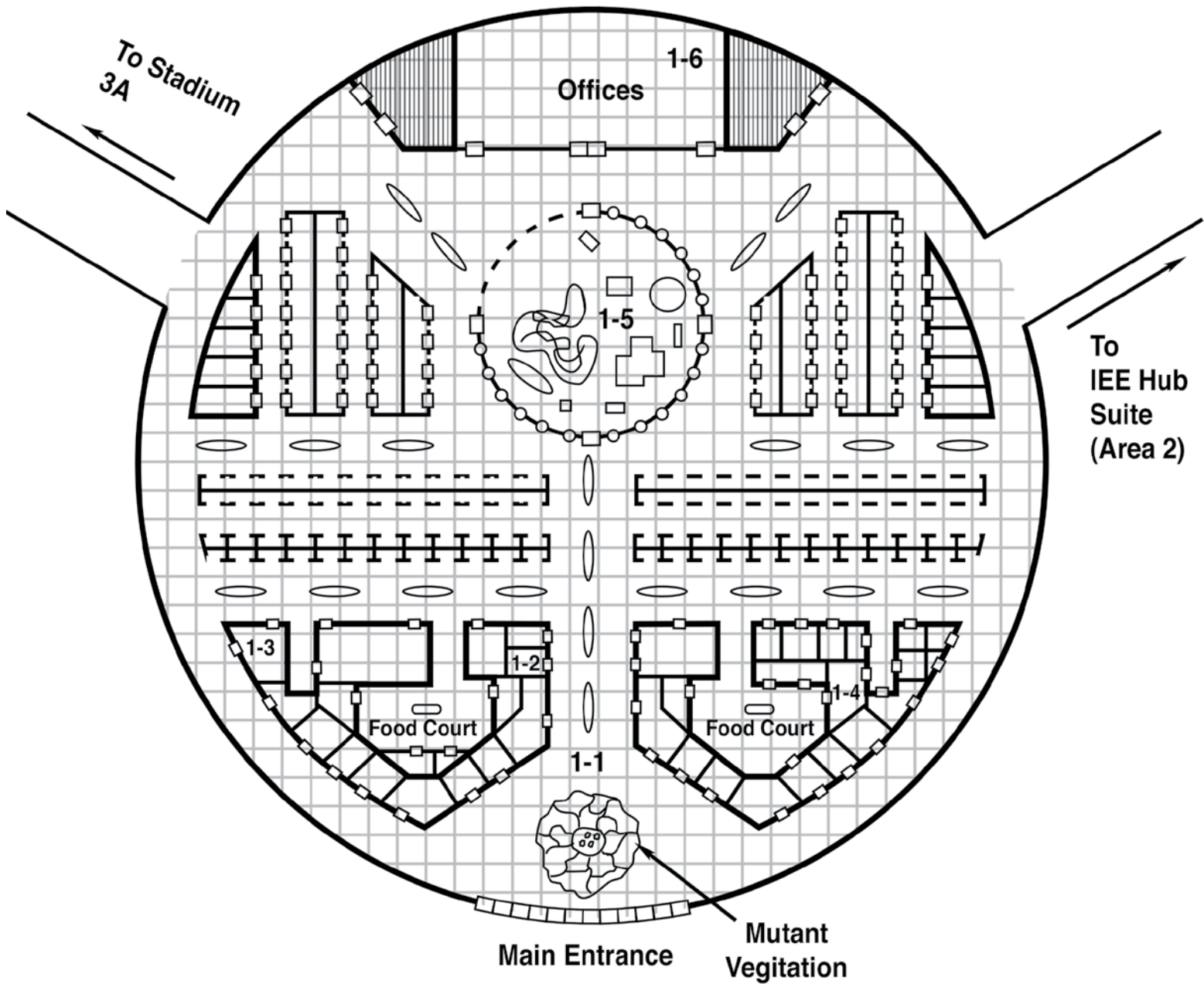
# OLYMPUS COMPLEX

## Entry Hub



-  = 30'
-  = Decorative Planter
-  = Auditorium Seating
-  = Doorway
-  = Shops

## RANDOM BUSINESSES OF THE ENTRY HUB

Referees looking to quickly generate the purpose of any of the Entry Hub shops and businesses can roll d% dice on the following table to determine its purpose prior to the catastrophe.

If necessary, an additional roll of 1d6 indicates how intact its contents are: 1-2) completely looted; 3) mostly looted (25% chance of something interesting being found); 4) partially looted (50% chance of something interesting remaining); 5) mostly intact (75% of something interesting remaining); 6) perfectly intact.

**TABLE 9-2: RANDOM ENTRY HUB LOCATIONS**

| D100   | LOCATION TYPE                    |
|--------|----------------------------------|
| 1-2    | Arcade, Futuristic               |
| 3-4    | Arcade, Retro-style              |
| 5-6    | Art Gallery                      |
| 7-8    | Athletic Shoe Store              |
| 9-10   | Bar & Grill                      |
| 11-12  | Bath and Beauty Goods Store      |
| 13-14  | Beauty Salon/Barber              |
| 15-16  | Billiards Hall                   |
| 17-18  | Burned Out Ruin                  |
| 19-20  | Candy Store                      |
| 21-22  | Cart Rental                      |
| 23     | Casino                           |
| 24-25  | Cinema                           |
| 26-27  | Clothing Store                   |
| 28-29  | Coffee Shop                      |
| 30     | Comedy Club                      |
| 31-32  | Dance Club                       |
| 33-34  | Dance Studio                     |
| 35-36  | Education Kiosk                  |
| 37-38  | Electronic Device Shop           |
| 39-40  | Exercise Equipment Shop          |
| 41-42  | First Aid Station                |
| 43     | Fun House                        |
| 44-45  | Gymnasium                        |
| 46-47  | Holographic Senso-rama           |
| 48-49  | Holographic Sports Trainer       |
| 50     | Hunting Simulation Experience    |
| 51     | Indoor Archery Range             |
| 52-53  | Information Booth                |
| 54-55  | Lost and Found                   |
| 56-57  | Luxury Goods and Finery          |
| 58-59  | Martial Arts Studio              |
| 60-61  | Massage Spa                      |
| 62-63  | Monster Lair (referee's choice)  |
| 64-65  | Music Entertainment Store        |
| 66     | Neutonic Dispensary              |
| 67-68  | Pachinko Parlor                  |
| 69-70  | Pet Groomers                     |
| 71-72  | Restaurant                       |
| 73-74  | Security Post                    |
| 75-76  | Snack Bar                        |
| 77-78  | Souvenir Stand                   |
| 79-80  | Sporting Event Ticket Sales      |
| 81-82  | Sports Bar                       |
| 83-84  | Sports Betting Facility          |
| 85     | Sports Equipment Supply          |
| 86     | Sports Medicine Clinic           |
| 87-88  | Sports Memorabilia               |
| 89     | Sports Museum                    |
| 90-91  | Tanning Salon                    |
| 92-93  | Temporary Hologram Tattoo Parlor |
| 94-95  | Theatre                          |
| 96-97  | Vacant Store                     |
| 98     | Vitamin Shop                     |
| 99-100 | Wine Bar                         |

The silver metal visible amongst the vegetation are the material goods of the trees' former victims. Buried beneath the vines and roots are two duralloy shields, a pair of laser binoculars, two brown color bands, and a type 2 laser pistol drained of power. A skeletal arm lodged in the jaws of one of the trees has a science (blue) color band still wrapped around its wrist.

## AREA 1-2—YUMMY SNACKS AND SUNDRIES

**The windows of this storefront are smashed and the interior is dark. From your vantage point, it appears that the shelves are bare, their goods carried off long ago by scavengers. Despite the empty shelves, several bulky objects remain towards the back of the business.**

This business provided visitors with light meals and various goods they might require during their visit to the complex. It was looted soon after the catastrophe. The interior shows signs that the store has served as a campground or lair at various points since then.

The bulky objects are refrigeration units that once held frozen treats, drinks, and similar goods, a countertop containing a broken register computer, and a Freezy-Fun™ icy drink dispenser. The Freezy-Fun™ dispenser was hit hard by the cosmic radiation cloud, its weird energies playing havoc with the chemicals of the slushy drink mix within. This spawned the Freezy-Fun™ sludge beast that still lairs inside the machine.

**Freezy-Fun™ Sludge Beast (1)** - AC: 8, Hit Points: 30, Movement in Spaces: 5, Radiation Resistance: 14, Constitution: 10, Mental Resistance: n/a, Strength: 6, Dexterity: 6

**Appearance:** The Freezy-Fun™ sludge beast is a 10' diameter puddle of electric blue chemical ice unaffected by warm temperatures. It slithers about silently, overwhelming prey by washing over them and dissolving their flesh and bones, assimilating the resulting slime into their own weird bodies.

**Normal Reaction and Attacking:** The sludge beast dwells inside the Freezy-Fun™ icy drink dispenser, unseen by explorers. It typically waits inside until it senses intruders in the store, then silently leaks out the dispenser's nozzle and attacks. It is always hungry, but can go years without feeding. It attacks by engulfing prey with its body (WC 2) and dissolving their flesh. It can engulf up to three creatures if within a 10' area.

### **Mutations or Defects:**

**ACIDIC NATURE:** The various chemicals comprising the sludge beast's body are highly caustic. Any

creature struck by the beast suffers 4 dice of damage. The damage continues the following round, but is reduced to 3 dice, then 2 dice on the subsequent round, and 1 die of damage on the fourth. Any treatment that nullifies acid stops the ongoing damage effect if applied to the victim.

**AMORPHOUS:** The slime creature can squeeze through spaces as small as ½" in diameter. Its liquid nature makes it largely unaffected by kinetic damage (such attacks inflict 1 point of damage only). Cold attacks inflict subdual damage only, freezing the sludge beast for a short (10-30 minutes) period.

**IMMUNITY TO MENTAL ATTACKS:** The sludge beast is too stupid to be affected by mental attacks.

The store was looted, but a few objects remain, the former belongings of the sludge beast's meals. Forgotten in dusty corners or underneath the bottom shelves are a yellow programmer color band, a single two-way radio headset unit, a slug projector (empty), and a canvas bag containing 5 tubes of universal food paste and two pepper spray grenades.



## AREA 1-3—DAYCARE FACILITY:

This well-lit space is littered with toys, small playground equipment, tables, chairs, beanbag seats, and protective padding on the floor. Tri-d screens along the walls depict an oscillating display of colorful cartoon figures and childish artwork. Two young girls with dark, shoulder-length hair and wearing coverall-style play clothes are playing happily amongst the plethora of entertainments.

This area entertained and safeguarded the children of the *Warden* whose parents wished to sample the Complex's games and entertainments without their offspring in tow. The human daycare staff was assisted by holographic playmates to ensure that every child had someone to play with. The two girls are the area's only still functioning holographic children.

The holograms are "Abigail Rose" and "Morgan Marie" who appear to be 8 and 5 years-old respectively. Composed of realistic-looking holographic projections, the "girls" act as if human children most of the time, begging visitors to play with them. They don't seem to mind if their requests are refused and go back to entertaining themselves. As holograms, they are immune to physical and mental attacks.

The girls know very little about events and conditions outside the daycare area. They say that occasionally people come and visit, but none stay very long and only a few play with them. Most are very mean and try to hurt them, but then they get mad and leave.

This area is a somewhat safe place for PCs to rest and recuperate as the complex's more dangerous inhabitants seldom come here. While in this area, random encounters only occur on a 1 in 12. But there is a lurking danger.

Due to a mixture of cosmic radiation and Zeus' fortification of the complex, the holographic girls both sometimes assume wildly different personalities and become solid light projections. This makes them dangerous to living creatures. Each time this area is visited or every 12 hours if the PCs make camp here, there is a 15% chance the holograms transform into murderous solid light ragamuffins. They act normally in this state until they have a chance to attack the party unaware.

**Abigail Rose and Morgan Marie, Holographic Murderous Moppets (2)** - AC: 4, Hit Points: 50 each, Movement in Spaces: 8, Radiation Resistance: 18, Constitution: 16, Mental Resistance: n/a, Strength: 10, Dexterity: 18

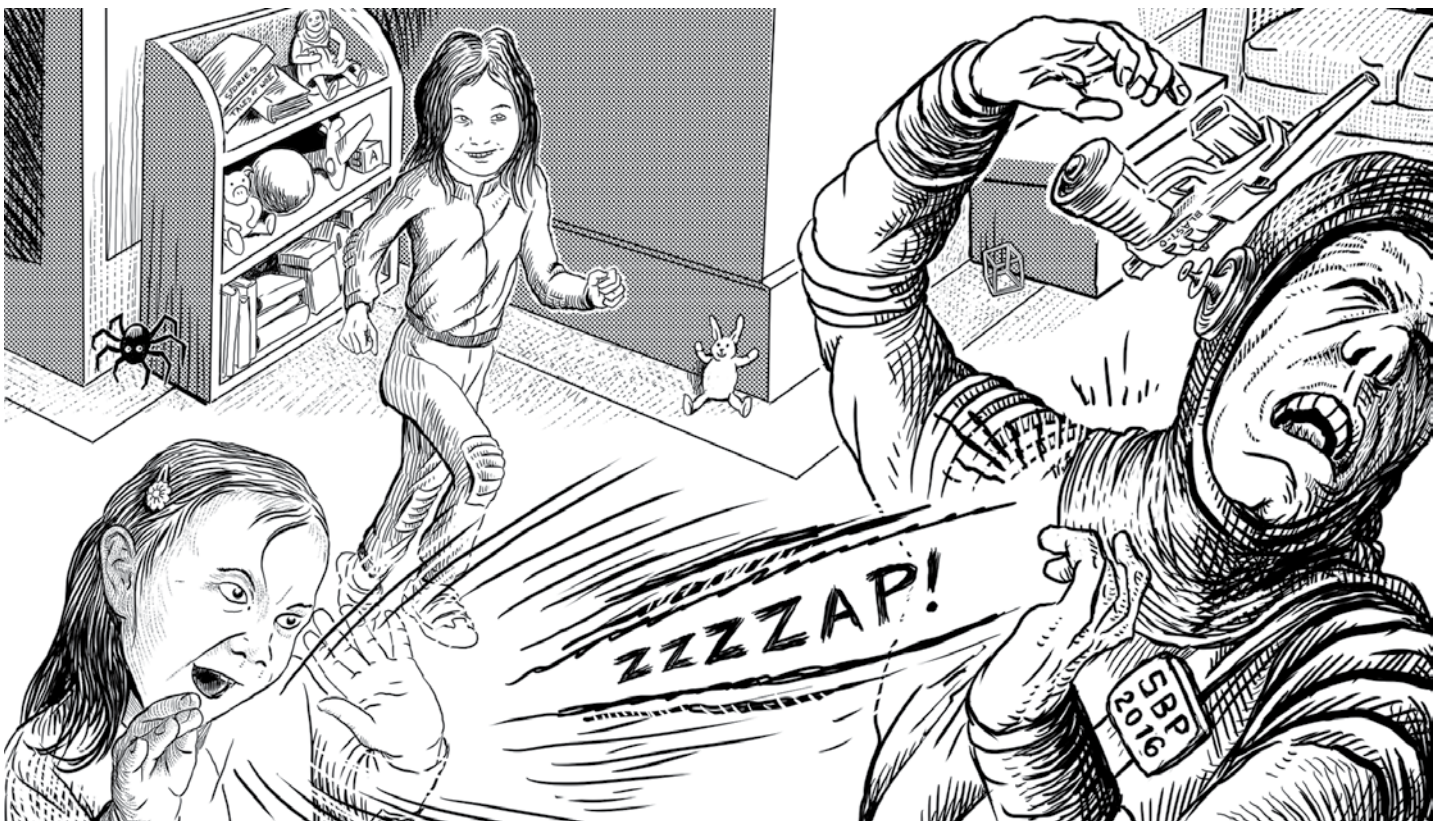

**TABLE 9-3: NEUTONIC COCKTAILS EFFECTS**

**D10 COCKTAIL EFFECTS**

- 1 **Restorative:** The drinker's body relaxes as aches and pains vanish and mild analgesic effects occur. The drinker regains 3d6 hit points if damage.
- 2 **Focusing:** The drinker's mind sharpens, allowing him to consider problems from new angles and make leaps of logic. He enjoys a +10% bonus when attempting to figure out artifacts for the next 1d4 hours.
- 3 **Mind-Eraser:** The drinker suffers amnesia, forgetting the events of the past 24 hours.
- 4 **Energetic:** The drinker's metabolism speeds up, granting him an additional attack each combat round and a +1 bonus to his speed. Unfortunately, his energized metabolism assimilates toxins more quickly. If exposed to poison, treat his Constitution as if it were 3 points lower (minimum of 3). Both these effects last for 1d6 hours.
- 5 **Poisonous:** Some of the pharmaceuticals in the dispenser were affected by the radiation cloud and are now poisonous. The drink dispensed is Intensity 15 poison.
- 6 **Cleanser:** A rich anti-oxidant brew, the cocktail purges the drinker of any poisons. If the drinker possesses an innate poison ability, it is lost for 1d4 hours. There is also a 5% chance the cocktail is so potent it permanently removes one of the drinker's defects.
- 7 **Cheer:** The drinker becomes happy and outgoing, but there is no other effect. This artificial cheer lasts for 1d3 hours.
- 8 **Radioactive:** The drink is contaminated with a random Class radiation that affects all within 20' of the dispenser. Roll 3d6 to determine the radiation's class.
- 9 **Stupor-Inducing:** The drinker succumbs to a pharmaceutical coma for 2d4 hours. Only advanced medicinal assistance, such as that from a first aid kit or medical bot, will rouse the unresponsive creature.
- 10 **Hallucinogenic:** The drinker experiences a series of benign sensory hallucinations that inspire wonder, laughter, and (rarely) deep insight. The consumer is distracted by these visions for 1d4 hours, during which his movement is reduced by half and he cannot perform any complex actions such as combat, mental mutations, or figuring out artifacts. His Leadership Potential is reduced by half as well during this time due to his obviously stoned state.

**Appearance:** The holograms appear as true human female children of approximately 8 and 5 years of age. Their hair and eyes are dark and they have mischievous smiles on their happy faces. They wear colorful blue and green one-piece coveralls with ribbed padding at the knees and elbows. When in solid light form, the occasional flicker that is sometimes seen in their holographic state is absent and astute observers might notice its absence, alerting them that something has changed.

**Normal Reaction and Attacking:** The girls behave as normal when in their murderous state—until they're ready to strike! Then they use their holographic power to blind their victims and attack the disadvantage foes with electrical blasts. If reduced to zero hit points, the solid light holograms vanish for 1d6 hours before reappearing in their non-violent guises. When normal holograms they have no memory of their actions while in their murderous state.

**Mutations or Defects:**

**CHARISMATIC EFFECT:** These holograms can create a flashing pattern of light up to 50 feet away. This effect covers a 5' diameter and blinds any creature caught in it for 1d10 melee rounds. Blinded creatures suffer a -4 penalty to attacks and opponents receive a +4 bonus to attacks against them.

**ELECTRICAL GENERATION:** These holograms can discharge a burst of electrical energy with a successful attack (WC 2). This blast inflicts 4d6 damage.

**IMMUNITY TO MENTAL ATTACKS:** As holograms, the girls are unaffected by any mutation that directly affects organic brains.

The area contains a bevy of children's toys and entertainment equipment, which is of little use or value (unless the referee decides otherwise). There is a culinary dispensing unit in one wall that provides nutritious and tasty meals and snacks for the daycare attendees. This device is Complexity 8. Successful use dispenses a delicious, healthy meal for 1d4 people.



## AREA 1-4—OWSLEY'S:

---

**A dusty, but intact recreational area is situated here. Body-hugging chairs and divans are placed in conversation-stimulating places around low tables. Each table has a strange device growing from its center, a number of small nozzles and buttons emerging from the object. The ceiling is covered entirely by dark tri-d screen and the floor bears colorful carpeting featuring swirling patterns.**

The detrimental effects of alcohol were well-known by the 23<sup>rd</sup> century and many people eschewed fermented beverages. However, social lubrication was still desired, albeit in non-depressive forms. Beverage companies worked with pharmacologists to create "Neutonic," a non-addictive pharmacological cocktail that could be custom-mixed to produce emotional and physiological responses in the drinker. Owsley's was a neutonic dispensary and, although neglected, it is still functional.

Each of the 30 tables in this dispensary has a neutonic dispenser imbedded in it. Customers could punch in their desired chemical ingredients to produce the neutonic cocktail they desired, but the PCs lack this knowledge. Figuring out how to use the Complexity 8 dispenser produces a 4 oz. serving of a random neutonic. Roll on Table 9-3 below to determine the cocktail's effects.

The dispensers are connected to mixing systems inaccessible from the dispensary and possess a seemingly infinite supply of drugs and chemicals. Drinks can be stored for future use and will last for up to 28 days in a sealed container before the pharmaceutical cocktails become inert.

## AREA 1-5—AMUSEMENT ZONE:

---

**A motley collection of amusement rides surrounded by a wrought-iron fence stand silent in the middle of a large plaza. Merry-go-rounds, roller coasters, Ferris wheels, and similar rides and attractions create a winding maze of machinery.**

Two dozen amusement rides and small attractions reside in this fenced-off area. Entrance is through the four-gated area requires any type of color band to bypass the turnstiles. The fence is 10' tall.

The amusement zone is home to a band of androids charged with patrolling the Entrance Hub and ensuring

the wolooids and other intruders stay out. They dwell in various makeshift huts and tents erected amongst the rides and attractions, venturing out in regular groups to patrol the shops and thoroughfares. There are a total of 30 androids stationed here, but only 1d10+1d6 will be present at any given time. The rest are out on patrol.

**Android Guards (30)** - AC:6 , Hit Points: 50 each, Movement in Spaces: 6, Radiation Resistance: 18 Constitution: 14 Mental Resistance: 16, Strength: 14, Dexterity: 14

**Appearance:** These androids bear the unnervingly blank faces of standard worker models. Only a pair of dead eyes and a narrow mouth adorn their faceplates. They dress in garishly-colored sports uniforms and carry lethal weapons issued to them by Zeus.

**Normal Reaction and Attacking:** The android guards use lethal force against wolooids and similar lupine mutants due to the ongoing battle with those tribes. They might (50%) attempt to take other types of intruders captive in order to interrogate them and learn if they're simply lone explorers or advance scouts for a larger force. The androids carry a mixture of lethal and subdual weaponry. Half are armed with type 1 laser pistols (WC 6, 7d6 dmg), a quarter carry slug projectors (WC 5, 2d6 subdual dmg), with the remaining one-fourth carrying paralysis rods (WC 3, 3d6 hours paralysis). Each other carries 1d6 hydrogen cells and a 25% chance of 1d4 slug projector ammunition clips. One in every four androids has a random color band. Roll 1d8: 1-4) brown; 5) green; 6) gray, 7) white, 8) red.

### **Mutations or Defects:**

None

Although the androids don't crave treasure, they've collected some interesting objects from defeated enemies and store them here. This collection consists of three brown color bands, a gray color band, 2 portable energy lamps, a foam-lined plastic case containing 10 canisters of chemical acid, a vibro-blade without a power cell, a gourd containing fermented mutant berry juice that makes the drinker immune to *life leech* for 1d6 hours but at a -1 penalty to hit due to tipsiness, a tube holding a greasy paste that reduces damage from heat and laser attacks by half if smeared over the body (lasts 12 hours or until washed off), a clip of slug projector ammunition, and six improvised bear traps made from the "mouths" of jawed plants. These last are WC 1 and inflict 2d6 damage if stepped on. Any creature damaged by the trap is also immobilized unless it can roll its Strength or less on 5 dice.

## AREA 1-6—FERAL ABE TRIBE:

---

**Workstations and contoured chairs are strewn about this carpeted space, hinting at its former purpose. Now, however, the area contains crude racks constructed from scavenged parts and bearing grisly trophies, a glowing light cube surrounded by nest-like heaps of clothing, and an atmosphere that reeks of spoiled meat. Humanoid figures move in the dim light, the shine of steel visible on their weapons.**

This area was once an office, but it is now the den of a tribe of ABE units long past their recycling date. Whether by accident or purposely, the artificial life forms went uncollected and are now in a decaying and feral state.

The debase creatures believe that they can fix their physical damage by integrating freshly harvested flesh with their own synthetic skin. They prey upon any organic life they encounter, and any such creature wandering into their territory is considered a potential skin donor.

**Feral ABE Units (10)** - AC: 7, Hit Points: 50 each, Movement in Spaces: 6, Radiation Resistance: 9, Constitution: 14, Mental Resistance: 16, Strength: 14, Dexterity: 15

**Appearance:** Feral ABEs are long past their intended operational lifespan and they show it. Their synthetic skin is torn and scuffed, appearing rotted and gangrenous. Patches of organic skin are crudely stitched to the fake flesh in a poor attempt to fix the damage. Feral ABEs carry a variety of melee weapons fashioned from scavenged junk, sports equipment, and pillaged artifacts. Like normal ABEs, their eyes are glassy and lifeless.

**Normal Reaction and Attacking:** Feral ABEs' cerebral chips are corrupt, leaving the artificial life forms in a primitive, violent state. They recognize other ABE units and form small tribes, but are otherwise antisocial and outright hostile to other residents of the Complex. They no longer respond to any instructions or commands from Zeus or any other source. These feral ABEs are armed with improvised weapons (WC 3; 1d8/1d6/1d6 damage) but three of them carry a flexing baton (WC 3, 9 dmg per strike), a vibro-machete (WC 4, 50 dmg to plants, 35 dmg to other targets), and a paralysis rod (WC 3, 3d6 hour paralysis) with 4 hours usage remaining.

### **Mutations or Defects:**

**POISON IMMUNITY:** Due to their artificial nature, ABEs are unaffected by poison of any type.

**PHYSICAL REFLECTION (PARALYSIS DART, SLUG PROJECTORS):** The hard, rubbery flesh of ABEs resist paralysis darts and the rubber bullets of slug projectors, reflecting them randomly away if struck by such projectiles.

The racks are made from scavenged bits of metal and plastic and contain steak-sized hunks of organic flesh being air-dried in preparation for ABE skin patching. The resting nests contain old uniforms, soiled and torn. One nest contains a breastplate of plant fiber armor (AC 5) fitted for a true human and an overlooked security color band.

The light cube is of normal type and has 8 hours of usage remaining. A woven bag beside it contains 10 hydrogen cells, 4 of which are fully charged (the rest of drained).

## AREA 2: IEE SUITES

---

This section of the Olympus Complex houses a cutting-edge entertainment and recreation technology: Immersive Entertainment Experience suites. A form of virtual reality, IEE was a cheap and safe method to experience activities and travel that might otherwise be beyond the capabilities of the user. Unfortunately for explorers of the Complex, this technology has been coopted by Zeus.

In addition to the offensive capabilities of the IEE technology, the Immersive Experience suites in the complex are still functional. These areas were specifically designed to affect the minds and bodies of those inside them and it is more difficult to shake the effects of the IEE in the suites than it is elsewhere in the complex.

### **GENERAL AREAS**





The following areas are present in the Entrance Hub but are left to the referee to develop as required.

**IEE Control Room:** Computer consoles that monitor all the IEE suites and the physical conditions of its users fill this dark, disused room. Blinking lights strobe quietly in the dark. This room is completely insulated from the surrounding IEE projection technology, making it one of the few places in the Complex where the PCs cannot be affected by an IEE attack by Zeus.

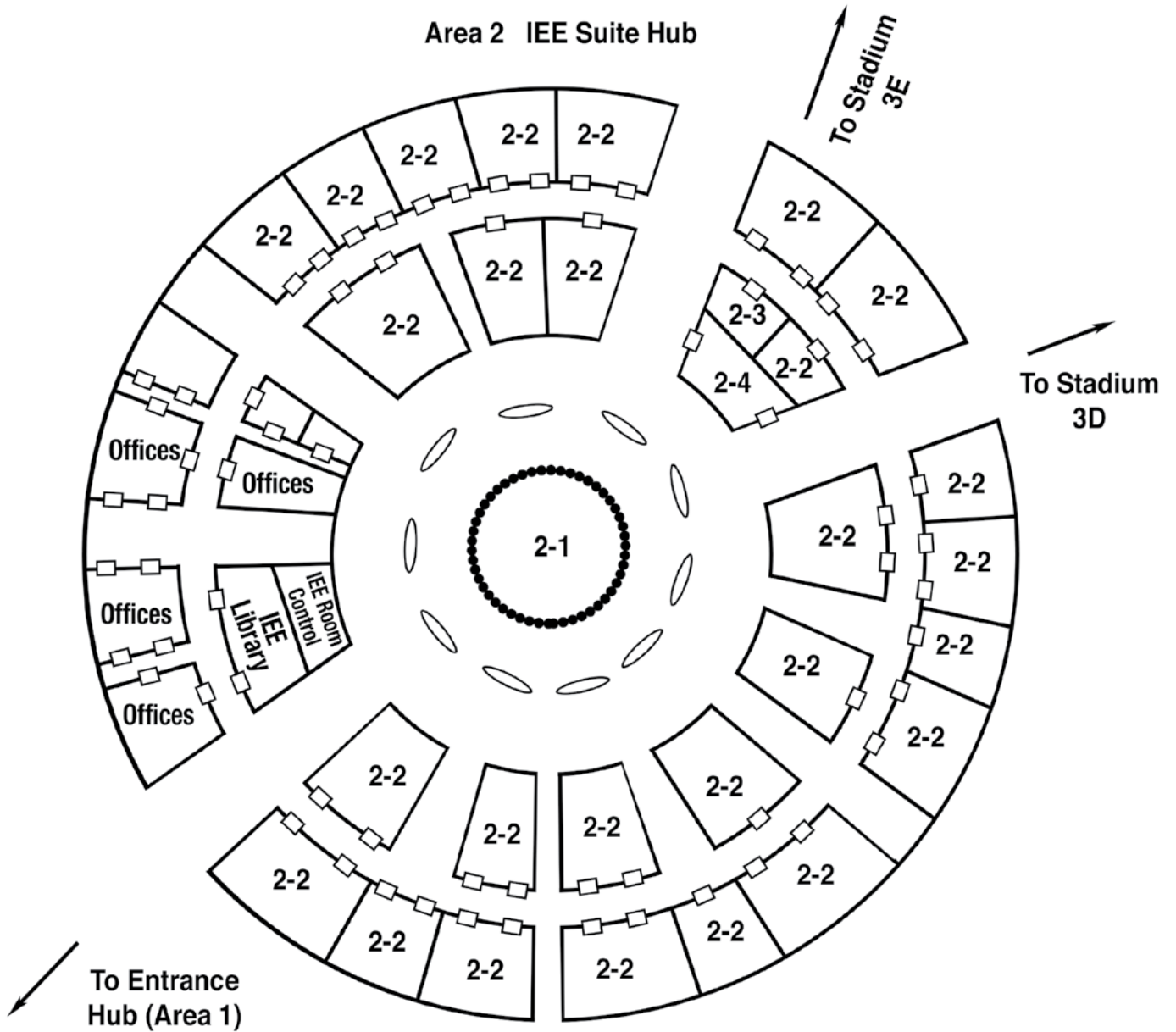
# OLYMPUS COMPLEX

## Area 2 IEE Suite Hub



-  = 30'
-  = Decorative Planter
-  = Door
-  = Piled Cart Palisade

North dependant on  
E.C. orientation

**IEE Library:** Numerous databanks house a vast storehouse of programmed IEE scenarios ready for projection. This area is well-secured and requires a science, engineering, or medical color band to enter. Some of the databanks are faulty, their scenarios corrupted, and it is from these libraries that Zeus draws his offensive IEE projections.

**Offices:** Similar to those in the Entrance Hub, this area is a collection of cubicles and offices that once handled the daily functioning of the IEE arm of Olympus. They are now empty and silent, and contain little of value.

### **AREA 2-1—ENTRANCE ATRIUM:**

A grand plaza stretching more than a hundred yards wide is splayed out before you. A glittering ceiling stands overhead like an artificial sky and beneath it are well-manicured bursts of vegetation. Ancient tables and chairs are stacked by the wayside, providing broad avenues of travel. In the heart of this space is an odd sight: a high walled-off section apparently encircled by ancient vehicles stacked one atop the other.

Once a welcoming area for IEE guests and a transportation hub for visitors bound for the stadiums, this atrium is now an android guard stronghold. The androids have constructed a crude fortress from numerous electrical carts and trams once used by staff and guests to traverse the expanses of Olympus. The stockade measures 20' tall and has both walkways and loopholes for guards to keep watch. Entrance is achieved by rolling a large tram out of the way, an act that requires a combined Strength of 36 or better. The walls, due to their ramshackle construction, are easily scaled.

There are 30 android guards stationed here. Ten watch from the parapet at any given time, while the rest attended to daily chores inside the stockade.

**Android Guards (30)** - AC:6 , Hit Points: 50 each, Movement in Spaces: 6 Radiation Resistance: 18, Constitution: 14 Mental Resistance: 16, Strength: 14, Dexterity: 14

**Appearance:** These androids bear the unnervingly blank faces of standard worker models. Only a pair of dead eyes and a narrow mouth adorn their faceplates. They dress in garishly-colored sports uniforms and carry lethal weapons issued to them by Zeus.



**Normal Reaction and Attacking:** The android guards use lethal force against wolfoids and similar lupine mutants due to the ongoing battle with those tribes. They might (50%) attempt to take other types of intruders captive in order to interrogate them and learn if they're simply lone explorers or advance scouts for a larger force. The androids carry a mixture of lethal and subdual weaponry. Half are armed with type 1 laser pistols (WC 6, 7d6 dmg), a quarter carry slug projectors (WC 5, 2d6 subdual dmg), with the remaining one-fourth carrying paralysis rods (WC 3, 3d6 hours paralysis). Each other carries 1d6 hydrogen cells and a 25% chance of 1d4 slug projector ammunition clips. One in every four androids has a random color band. Roll 1d8: 1-4) brown; 5) green; 6) gray, 7) white, 8) red.

**Mutations or Defects:**

None

Although the walls are made from inoperable vehicles, the androids of the fort own five working electrical transport carts that are used by the guards on long-range patrols. There is a 50% chance 1d4 of them are out with a guard patrol at any given time. These carts can carry six passengers, travel at a top speed of 30 MPH, and runs on solar batteries that provide 24 hours of operation before needing recharging. Each cart is AC 5 and has 100 hit points

The vegetation in the atrium is non-hazardous and well-tended by the Complex's maintenance robots.

---

### AREA 2-2—IEE SUITES:

---

**This large auditorium is filled with padded furnishings resembling large benches or narrow beds. Every surface is covered with spongy gray material seemingly woven with glittering metal. Numerous blue-colored and shiny half domes protrude from the ceiling.**

Each IEE suite could entertain between 500 and 1000 guests at a time. Each user would lie down on one of the padded chairs and the immersive technology would provide a hallucination of their choosing. Weak force field restrains kept the user from moving and potentially injuring himself or others while undergoing the IEE.

A small interface on the side of each divan controlled the IEE. Using one of the beds properly requires a roll to operate Complexity 3 devices. Correctly operating one of the beds causes a weak force field to surround

the bed itself, immobilizing anyone lying on it (creatures of Strength 8 or less cannot move, stronger individual can break free in one round). The following round the IEE user is subjected to a Mental Resistance 18 mental attack. If the attack succeeds, the user experiences an entertaining IEE (see Appendix below). This hallucination lasts for 2d4 hours unless interrupted.

Zeus, however, can trigger an IEE anytime it desires, targeting anyone in the suite. Any IEE projection in the suites, whether entertaining or offensive, is treated as a mental attack from a source with a Mental Resistance of 18.

---

### AREA 2-3—PSYCHOLOGICAL EVALUATION AREA:

---

**A carpeted waiting area with brightly colored tri-d art depicting exotic locales is located here. A small desk faces the chairs and couches, while a closed door stands in the far wall.**

Guests who had never previously used IEE technology had to undergo a brief medical and psychological evaluation before doing so, just as a safety precaution. These interviews and physicals were conducted here. The waiting area is unoccupied and contains nothing of interest, but beyond the closed door is a cozy office complete with ergonomic desk, traditional leather couch, calm watercolor paintings on the walls, and a human-looking psych-bot.

**Psych-bot (1)** - AC: 4, Hit Points: 30, Movement in Spaces: flying 75, Radiation Resistance: 12, Constitution: 10 Mental Resistance: 15, Strength: 9, Dexterity: 6

**Power System:** Broadcast power

**Body Style:** Humanoid

**Motive System:** Hover

**Miscellaneous Systems:** Human Normal Sensor Package, Short Wave communication package, 1st & 2nd level computer package, 1st level medical package, hypno-psycho-diagnostic package.

**Appearance:** From the waist up, the psych-bot resembles an almost human-looking female with synthetic red hair, confidence-inspiring eyeglasses, and wearing a soft, robin's egg blue sweater. Below the waist, it is an oval hover unit that operates in a hushed whisper mode. The psych-bot's optical units resemble startling green eyes it is easy to get lost in.

**Normal Reaction:** When operating properly, the psyche-bot engages patients in a complex algorithm of questions designed to root out any deep-seated psycho-

logical conditions that might be aggravated by an IEE session. However, the radiation cloud and neglect has affected this unit and, although it has good intentions, its questionings have a potential detrimental effect on any patient undergoing the process.

Any intelligent creature subject to mental attacks who interacts with the psych-bot is affected by a mental attack. This attack manifests as a series of personal questions that the target feels drawn to answering. If the attack succeeds, the target becomes hypnotized by the robot and is incapable of doing anything but responding to the questions until the bot completes its diagnosis. This process takes 10 minutes. The hypnotized PC can be roused from the stupor as if undergoing an IEE (see Appendix below)

A creature affected by the hypno-questioning must roll 1d20 after the process ends. If interrupted before the questioning is completed, the player subtracts -5 from the roll. If the result is greater than the PC's Mental Resistance score, the subject manifests a mental defect of a psychological nature as determined on the table below.

TABLE 9-4: PSYCH-BOT MENTAL DEFECT TABLE

D4 NEW MENTAL DEFECT

- 1 **Kleptomania:** The PC must roll his Mental Resistance of less on 3d6 whenever a new treasure is discovered by the party. If the roll exceeds his ability score, he will attempt to steal the item at the first possible opportunity.
- 2 **Fear Impulses for Types:** As per the METAMORPHOSIS ALPHA rules. The referee determines the type randomly or chooses something appropriate.
- 3 **Luddite:** The PC develops an irrational hatred for any technology more sophisticated than the bow and arrow and fire. He can never willingly acquire or touch technology while affected by this defect.
- 4 **Homicidal Impulses:** The PC must kill a sentient living creature each day. If he fails to do so, there is a cumulative 1 in 6 chance each day he goes berserk and attempts to slay a random person in his immediate vicinity. Doing so satiates his bloodlust.

**Time and neglect has dirtied the once-white walls marking the perimeter of this bed-filled space. Tube-shaped beds with cracked glass viewplates are aligned against one wall facing ordinary single beds across a broad aisle. Piles of refuse and machinery fill the corners. A band of blank-eyed human figures, their bodies a mixture of metal and rubbery flesh, stalk across the room, seemingly displeased with your presence.**

Formerly a place where medical emergencies were treated and athletes' bodies were repaired, this space is home to a strange band of ABE units. These artificial life forms have discovered the benefits of using the ten rebuilding tubes here to keep their decaying bodies functioning.

**Bionic-Augmented Feral ABE Units (7) - AC: 7, Hit Points: 50 each, Movement in Spaces: 6, Radiation Resistance: 9, Constitution: 14, Mental Resistance: 16, Strength: 14, Dexterity: 15**

**Appearance:** Feral ABEs are long past their intended operational lifespan, but have prolonged their existence thanks to the bionic body replacement tubes found in the med center. Their chemically-decaying synthetic flesh is bonded to mechanical limbs that whine with ill-maintenance. The bionic replacements vary from model to model, giving the band a motley appearance.

**Normal Reaction and Attacking:** Feral ABEs' cerebral chips are corrupt, leaving the artificial life forms in a primitive, violent state. They recognize other ABE units and form small tribes, but are otherwise antisocial and outright hostile to other residents of the Complex. They no longer respond to any instructions or commands from Zeus or any other source. These feral ABEs are equipped with bionic parts as follows:

Bionic-armed ABEs (3): These units gain a +2 die bonus to damage.

Bionic-legged ABEs (2): These units are -2 to be hit due to faster movement and have a MIS of 12.

Bionic armed and bionic respiratory system (2): These units gain a +2 die bonus to damage and attack twice per round.

These feral ABEs are armed with improvised weapons (WC 3; 1d8/1d6/1d6 damage)

**Mutations or Defects:**

**POISON IMMUNITY:** Due to their artificial nature, ABEs are unaffected by poison of any type.

**PHYSICAL REFLECTION (PARALYSIS DART, SLUG PROJECTORS):** The hard, rubbery flesh of ABEs resist paralysis darts and the rubber bullets of slug projectors, reflecting them randomly away if struck by such projectiles.

The litter in the corner is junk, but PCs searching through it have a 10% chance of finding a random treasure item from the list in the METAMORPHOSIS ALPHA rulebook as determined or chosen by the referee.

The ten rebuilding tubes were designed to replace damaged limbs and organs with bionic prosthetics should an athlete suffer major injuries on the field. Three of the tubes are still functioning and are Complexity 2 items. If its function is correctly deduced and the tube is activated, it replaces a random organ or limb of any creature inside it with a bionic part. Roll on the Bionic Supplement tables (see METAMORPHOSIS ALPHA deluxe edition) to determine what body part is replaced and its effects or, should the referee lack access to that material, determine the replacement and game effects yourself.

The three functioning tubes will each work 3d6 times before they run out of bionic replacement parts.

## AREA THREE: THE STADIUMS

There are twelve stadium spread throughout the Olympus Sports Complex, each one catering to a variety of athletic competitions and games. Each share similar designs and can be customized as needed to accommodate a number of sports.

Each stadium holds up to 20,000 spectators in seats ranging from distant yet comfortable seating at the verge of the arena to luxurious spectator boxes situated in prime viewing locations. These seats are arranged in rising tiers that encircle the entire circumference of the stadium. A main corridor runs around the outside of each stadium, providing numerous points of access to the stands, as well as containing eating venues, restrooms, souvenir stands, and similar facilities.

The stadiums are completely enclosed so weather never interrupts a game. The ceilings of the stadiums are covered with tri-d holographic panels capable of creating the illusion of the outdoors as well as projecting advertising images, close-up pictures of the action on the field, and general announcements delivered by sporting legend “talking heads.”

The playing fields of the stadium are composed of interchangeable sections that can be swapped out to create an array of playing surfaces. Thanks to this feature, each field can be customized to accommodate a wide variety of sports. One stadium also has special gravity generators to allow for zero-gee athletic competitions.

### STADIUM LAYOUT

There are twelve stadiums spread across the Complex, with each hub containing two stadiums stacked one atop the other. They are laid out as follows:

Stadiums marked with an \* are detailed further in this supplement. The remainder are left to the referee to flesh out or replace to best suit his or her own campaign.

**TABLE 9-5: OLYMPUS COMPLEX STADIUM LAYOUT**

| STADIUM HUB KEY | LOWER STADIUM (WITH KEY)        | UPPER STADIUM (WITH KEY)     |
|-----------------|---------------------------------|------------------------------|
| <b>3A</b>       | Retro Sports (3A-1)*            | Hoverboard Racing (3A-2)     |
| <b>3B</b>       | Power Jai Alai* (3B-1)          | Decaying ABE Storage* (3B-2) |
| <b>3C</b>       | Overgrown Mutant Jungle (3C-1)  | Uhways Village* (3C-2)       |
| <b>3D</b>       | Demolition Bot* (3D-1)          | Ice Hockey (3D-2)            |
| <b>3E</b>       | Bashball Arena* (3E-1)          | Football/Soccer (3E-2)       |
| <b>3F</b>       | Mixed Martial Arts Arena (3F-1) | ZeeGee Arena* (3F-2)         |

## GENERAL STADIUM FEATURES

The following areas are present in all stadiums and described briefly here for the referee's use in fleshing out these spaces for exploration. Significant changes to these areas are described in separate stadium keys later in this work.

**Outer Ring:** Outside the stadium proper and running adjacent to the main access corridor that spans the outer edge of the enclosed area are numerous establishments catering to the needs of the fans. This ring contains washrooms, restaurants, souvenir stands, sporting goods stores, sports bars, and the like. Additionally, security posts, information cubicles, and elevators are also found around the stadium's outer perimeter. The referee can detail these venues as desired or use Table 9-2 above to determine their nature randomly.

Several doors lead from the outer ring into the stadium underlevel. These doors are typically locked, but most any color band other than the brown general purpose band will open them, allowing access to the areas underneath the seating stands.

**Elevators:** There are eight large elevators placed equidistance from each other around the stadium. Each elevator serves the outer ring access corridor, the seating stands, and the stadium above or below this one. Any color band will call the elevators.

**Seating Stands:** Surrounding the playing field proper are tiers of seats accessible via the elevators and the stadium entrances. Each seat is padded for comfort and bears a small tri-d screen, food and beverage holder, and personal comfort controls that adjust the temperature and incline of the seat. During a game, attendees can view vital statistics, zoom in on the action, and order additional refreshments via the tri-d screen.

In addition to these personal seats, there are twenty-six private boxes overlooking the playing field. These boxes contain luxurious seating, giant tri-d screens, private lavatories, robotic butlers, and an array of fresh foods and drinks served during the game. Access to these luxury boxes requires a special key code in addition to a color band. PCs without this key code can bypass the lock by overcoming the Complexity 5 device.

**Stadium Underlevel:** This area is situated beneath the seating stands and contains all the unglamorous facilities a stadium requires to function: power networks,

plumbing and sewage services, equipment storage, stadium component storage, even laundry facilities for team uniforms. It also contains locker rooms, playing field maintenance, equipment storage, press rooms, and similar services. Access to these areas are restricted and require a red, gray, white, green color band, or a command ring to enter. Further notes on these specialized areas are as follows:

**Blimp Garage:** Each stadium is equipped with a Complexity 3 dirigible that could be piloted by a single person. The blimp was deflated and stored here in between games. Huge helium canisters are also present to inflate the blimp as required. The blimp has a top speed of 15 MPH and can remain aloft for 48 hours before its batteries need recharging.

**Equipment Storage:** These rooms contain numerous lockers, bins, equipment cages, and similar containers that hold a variety of sports equipment. The Olympus Complex was designed to host hundreds of different sports and athletic competitions and there is no lack of equipment and tools to provide for them. The referee can determine the contents of each container in an equipment locker if desired or roll randomly on the following table to see what the PCs discover in their searching.

TABLE 9-6: EQUIPMENT STORAGE CONTENTS TABLE

### D12 EQUIPMENT FOUND

|    |  |
|----|--|
| 1  | Sports padding for 1d10 players (-1 AC bonus if worn)                        |
| 2  | 2d20 sports helmets (head protection if worn; effects determined by referee) |
| 3  | 2d20 hockey sticks (can be used as a normal mace)                            |
| 4  | 3d6 baseball bats (can be wielded as a larger, heavier mace)                 |
| 5  | 2d20 inflated balls (referee's choice of type)                               |
| 6  | 1d100 pairs of sneakers  |
| 7  | Empty  |
| 8  | 3d10 force racquets (futuristic tennis racquets with force field strings)    |
| 9  | 1d10 clean uniforms (see Laundry below for benefits of wearing one)          |
| 10 | 1d6 first aid kits   |



# OLYMPUS COMPLEX

## Stadiums 3A - 3F

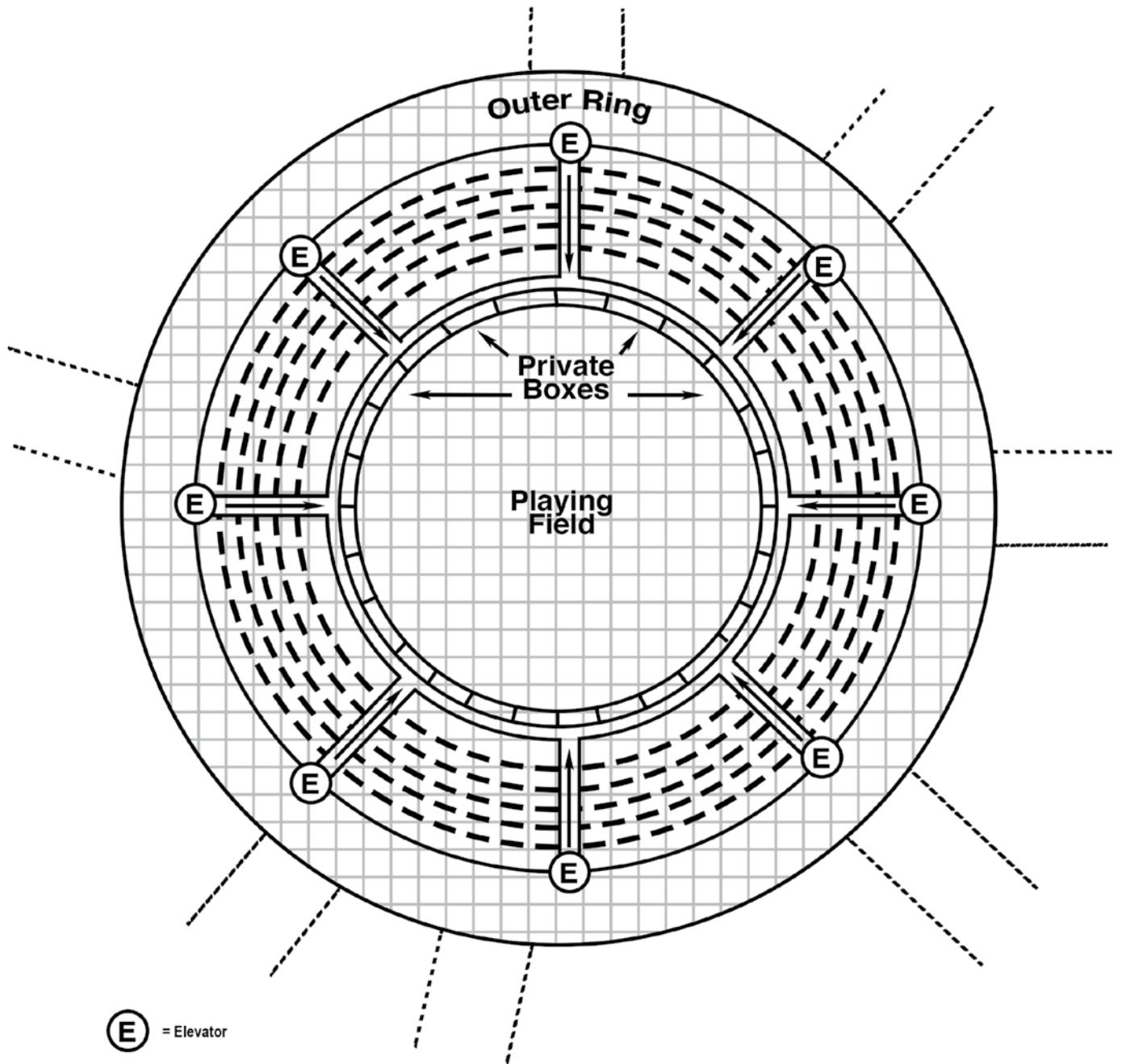

**E** = Elevator

 = 30'/10 yards

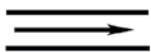
 = Ramp

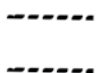
 = Possible connecting hallway (see master stadiums map)

 = Seating

**Greenkeepers Facility:** These areas once held a variety of equipment for caring for the natural grass surfaces used in the stadiums. Most have been stripped of useful tools and equipment, but overlooked chemicals, herbicides, and similar treasure might still be found. One of the facilities (see below) contains its full inventory of riches, but they are protected by an odd life form.

**Laundry:** These spaces hold industrial-sized washers and dryers to handle the numerous uniforms and other clothes that get dirtied during games. Large detergent canisters, bleach capsules and similar cleansers are present, as are piles upon piles of uniforms, both freshly cleaned and awaiting washing.

**Uniforms:** Explorers might loot some of these uniforms during their search of the Complex. This can be to their benefit and detriment. The uniforms have no inherent value or function aside from clothing, but ABE units and sports androids may react unpredictably to a PC wearing one of these team shirts. There is a 25% chance each time a non-feral ABE unit or sports android encounters a party wearing team uniforms that the artificial life form reacts to the uniform. If a reaction occurs, roll 1d6 to determine the creature's response: 1-4) the artificial life form has an intense dislike for the rival team and automatically attacks the wearer(s); 5-6) the life form is a member of that team and responds favorably to the wearer. ABEs and androids responding favorably consider the wearer to be an ally and will help them if possible. The uniform wearer is treated with respect, and aid and advice is provided, but the creature will not place itself directly in harm's way for the individual. If attacked or otherwise mistreated by the wearer, this friendship becomes immediate hatred with an appropriate response by the android or ABE.

**Locker Rooms:** These spaces contain lockers, showers, and similar facilities for the various sporting teams. There is a 33% chance that any given locker room is occupied by 3d6 ABE Units and 1d3 Android Coaches (stats as above). These athletes are not automatically hostile, and the referee should determine the artificial life forms' reactions based on the PCs' actions. PCs playing the role of avid fans might garner a much better response from the android coaches.

**Playbot Storage:** These rooms held the numerous robotic referees used by the stadiums. (see area 3A-F—Playbot Storage for further details).

## COMPLICATING MATTERS: RIVAL TEAMS

The above methods of determining an android or ABE's response is a simple one intended to speed play. However, some referees (the author included) prefer to complicate matters whenever possible. If the reader is one such individual, he can do so by detailing different types of uniforms and determining how the various factions of artificial life respond to the different teams.

One way to do so is to assign reactions to each color of uniform, much like the color bands found on the ship. For example, red and white uniforms might automatically anger androids and ABEs in stadium 3A1, but make the wearer allies with the ones in stadium 3E2. Blue and black uniforms do the exact opposite and so on until a web of reactions is created. While making things more difficult to keep track of, it does follow the ethos of METAMORPHOSIS ALPHA of experimenting and learning from the results. Adjudicated in this matter, observant PCs can make note of which uniforms evoke what reaction from the various android and ABE tribes and use this knowledge to their own benefit.

**Playing Field Storage:** Larger sports equipment such as goal posts, football goals, backstops, etc. are stored here when not in use. These spaces also hold the hexagonal field sections of various types used to customize the playing fields (see below), arranged by type for easy accessibility.

**Press Room:** These rooms hold podiums, seating, and prominently displayed team logos. Most are empty, but their neglected nature makes them natural lairs for mutations secretly dwelling inside the Complex or radioactively-spawned hazards that crept away from others. There is a 15% chance a random mutant dens in each of these spaces.

**Utilities Room:** Dark, dirty spaces filled with leaky pipes, chugging pumps, crackling generators and other equipment that keeps the stadiums running. All manner of mutants and hazards might lurk here in the dark.

# OLYMPUS COMPLEX

## Stadium Under Level

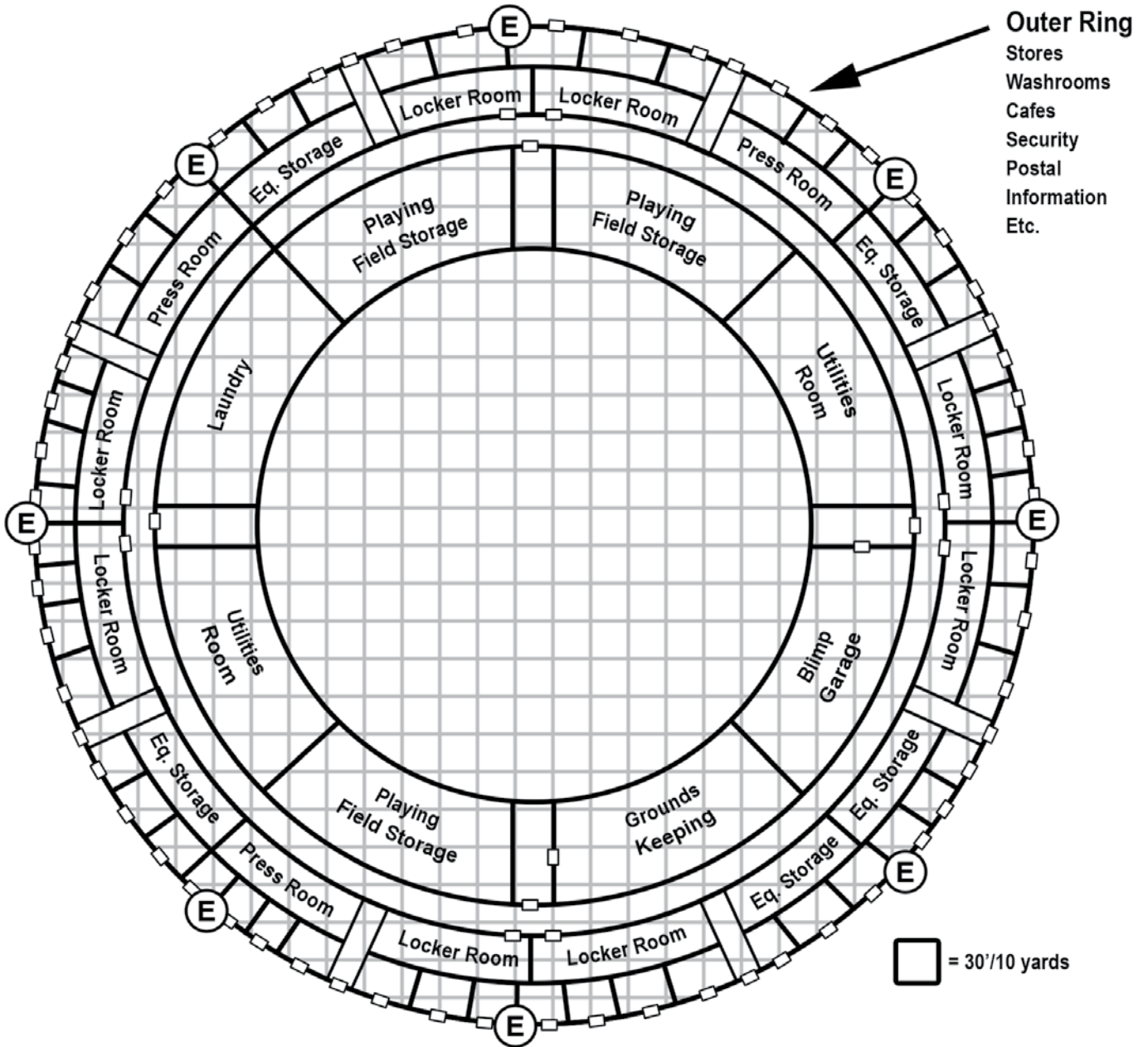

**Playing Field:** Comprised of a gridded networks of support struts laid over the sublevel below, the stadium's playing field is infinitely customizable for a variety of sports and athletic contests. Hexagonal sections of study synthetic material bearing natural grass, AstroTurf, plasticrete, dirt, and other playing field substances can be swapped in and out to create the necessary field. The field can even be rendered watertight and flooded for water sports and demonstrations.

During a game, the airspace above the playing field contains a number of drone cameras that record the action without inhibiting the fan's views of the field. A single, one-man dirigible is also sometimes used to record plays and provide advertisement space. This small blimp is stored in the inner ring when not in use (see above).

## STADIUM ENCOUNTER KEYS

---

NOTE: All twelve stadiums use the same floorplan. The following key uses a special indicator to note which of the twelve stadiums the keyed encounter is located on, followed by the name of the area as indicated on the stadium map. Thus, "Area 3B-2: Laundry Room" is located in the upper level of Stadium Hub 3B as indicated on the chart above. PCs exploring the laundry rooms on other stadium levels will not find the keyed encounter.

### AREAS 3A THROUGH 3F—PLAYBOT STORAGE:

---

**This room contains rows upon rows of silent, unmoving mechanical men. Resembling human figures painted with black and white stripes, the bots stare vacantly into space, awaiting activation.**

Each stadium contains one of these rooms that hold 15 inactive playbot referee robot units. They are activated as needed and sent to the stadium's playing field to oversee athletic competitions. Playbots can be activated by either Zeus or a PC making a Complexity 3 artifact roll. However, there is a 25% chance any playbot activated by a PC malfunctions, attacking any "offending players" it encounters. Activated playbots that are functioning normal automatically obey any creature with an engineering color band.

**Playbot (15) - AC: 4, Hit Points: 50, Movement in Spaces: 12, Radiation Resistance: 6, Constitution: 6, Mental Resistance: 10, Strength: 10, Dexterity: 12**

**Power System:** 48-hour battery pack

**Body Style:** Humanoid

**Motive System:** Two legs

**Miscellaneous Systems:** Human Normal Sensor Package, Short Wave communication package, 1st & 2nd level computer package, video recording package (up to 48 hours of video footage storage), complete sports rules database package

**Weapon Systems:** Some have an improvised blunt weapon (WC 3, dmg 1d8)

**Appearance:** Playbots are human-sized and -shaped robots with striped black-and-white chassis that resemble a referee's uniform. Playbots that have gone mad typically carry a piece of sporting equipment or improvised blunt weapon with which to beat "offending players."

**Normal Reaction and Attacking:** Playbots are robotic referees, mechanized units programmed with the rules to every sport known to humanity. They are also equipped with tri-d video cameras to capture the action on the field for both viewing entertainment and to review questionable plays. Playbots are typically non-threatening when working properly, although they have been known to summon security bots to escort "players" who fail to abide by the rules of play from the field. Malfunctioning, mad playbots are more of a threat as they deal with offending players personally, beating the rules violator to death with an improvised weapon, usually while shouting "Off sides!!!" or otherwise quoting the violation the offending party is supposedly guilty of.

### AREA 3A-1—RETRO SPORTS PLAYING FIELD:

---

**The air smells of freshly mowed grass and the holographic sky above depicts a beautiful summer day. The field is laid out with a number of straight white lines demarking a pastoral-looking play grid. Figures dressed in fresh uniforms engage in complex sports rituals, intent on this ancient game.**

There is always a game underway in this stadium. Most of the time, it is a classic sport, one considered "old-fashioned" by 23rd century standards. Baseball, football (both American and European), cricket, and similar sports are played here around the clock on a set schedule. The ABE units present on the field have skill chip sets to accommodate pick-up games and these units were intended to be friendly competitors for colonists seeking a bit of sports action. There are currently 3d4 ABE units and 1 android coach present playing a sport of the referee's choosing.

Non-threatening PCs are approached by an android coach who inquires if they're up for some friendly competition. It even explains the rules if the characters are unfamiliar with the sport (a probable thing). If the PCs agree, the ABE athletes gather together and the contest begins.

The ABEs actually adhere to their programming and play according to the rules of the game. Resolve the game by having the PCs roll 1d10 vs. the referee's roll of 1d20 (the ABEs are much better athletes and far more experienced in the game). Whichever side rolls highest wins the match. The referee can increase the PCs' die to 1d12 or even 1d20 if they have mutations that help them competitively.

During the match, the android coach approaches one of the PCs and suggests a friendly wager. It's willing to match anything the PCs have to offer, giving them 5 to 1 odds against them. If the PCs accept the bet and manage to win, the coach reveals its true nature (a slimy welcher) and commands the ABE units to beat the PCs to death. If the PCs lose, it graciously collects its winnings and is willing to continue wagering in subsequent games until the party defeats his team. Refusing to place a bet results in grumbling from the coach but no negative reaction.

**Android Coach** - AC:6, Hit Points: 50, Movement in Spaces: 6, Radiation Resistance: 18, Constitution: 14, Mental Resistance: 16, Strength: 14, Dexterity: 14

**Appearance:** This android appears as a faceless true human. It wears either a sweat suit bearing its team's logo or a natty business suit. A whistle on a cord hangs from around its neck.

**Normal Reaction and Attacking:** Android coaches are programmed to guide their teams to victory and many take this programming too far, caring only for a spotless record. Some will cheat to win, while others arrange accidents to happen to promising opponents. In extreme measures, the android can attack with its fists (WC 2, 2d10 dmg), usually while shouting nonsensical phrases (insert your favorite sports chants here).

**Mutations or Defects:**

None

**Artificial Biological Entity (ABE)** - AC: 8 (uniform) or 5 (protective padding), Movement in Spaces: 6, Hit Points: 60 each, Radiation Resistance: 11, Constitution: 16 Mental Resistance: 18 Strength: 16 Dexterity: 16

**Normal Reaction and Attacking:** These ABEs play their best against the PCs if challenged, bearing them no animosity and actually complementing them on their game. If their coach commands them to rough up the party, they do so, but in a mechanical, non-personal manner. Depending on what sport the ABEs were playing, they are either armed with sports equipment (WC 3; 1d8/1d6/1d6 damage) or unarmed (WC 1; 1d4/1d3/1d4 damage).

**Mutations or Defects:**

**POISON IMMUNITY:** Due to their artificial nature, ABEs are unaffected by poison of any type.

**PHYSICAL REFLECTION (PARALYSIS DART, SLUG PROJECTORS):** The hard, rubbery flesh of ABEs resist paralysis darts and the rubber bullets of slug projectors, reflecting them randomly away if struck by such projectiles.

---

**AREA 3B-1—POWER JAI ALAI PLAYING FIELD:**

---

**The playing field of this stadium is covered with green ferrocrete marked with angled white lines. Several tall walls are arranged in an octagon shape around the center of the field. Narrow gaps between the walls allow players to enter the enclosed space.**

The sport of jai alai enjoyed an immense popularity surge in the years prior to the *Warden's* departure, largely due to new rules that added accelerated play and higher potential for injury. This version of the game, known as power jai alai, utilizes energized *cestas* (the "racquets" used to hurl the ball) to throw the jai alai ball at immense speeds creating more highly unpredictable bounces and greater chance of injury. Unlike normal jai alai, power jai alai uses an octagonal court with eight walls and fields two teams of four.

A power jai alai game may be underway when the PCs enter (50%) chance. Eight ABE units are in the octagonal playing field dodging and returning a ball traveling at tremendous speed. Only the energized *cestas* can catch the ball safely. The players resent interruptions to their game and attack intruders with their energy *cestas*, grabbing additional balls from a box on the court so that all eight can attack.

**ABE Power Jai Alai Players (8)** - AC: 5 (protective padding), Movement in Spaces: 6, Hit Points: 60, Radiation Resistance: 11, Constitution: 16, Mental Resistance: 18, Strength: 16, Dexterity: 16

**Appearance:** These ABE units are very battered from grazes with the power jai lai ball. They wear white trousers and helmets and solid color polo-style shirts with sewn-in padding. A metal cesta is strapped to their right arm and bears a shimmering energy field around it.

**Normal Reaction and Attacking:** The ABE jai alai players unleash a barrage of balls accelerated by their energy cesta. This is a WC 6 attack that does 30 points of damage. When the ball strikes its victim, there is a 15% chance the target is knocked unconscious for 1d6×10 minutes from the force of the blow. After successfully striking an opponent, the ball rebounds off the victim, strikes a random wall, and is scooped back up by an ABE jai alai player to launch the following round. If forced to fight in close combat, the ABEs use their powered cesta as bludgeons (WC 3, 2d6 dmg).

#### **Mutations or Defects:**

**POISON IMMUNITY:** Due to their artificial nature, ABEs are unaffected by poison of any type.

**PHYSICAL REFLECTION (PARALYSIS DART, SLUG PROJECTORS):** The hard, rubbery flesh of ABEs resist paralysis darts and the rubber bullets of slug projectors, reflecting them randomly away if struck by such projectiles. Powered jai alai balls inflict normal damage due to their high speeds.

### **AREA 3B-2—DECAYING ABE STADIUM PLAYING FIELD:**

In the middle of this stadium's playing field is the crashed wreck of a vehicle. The crumpled cab of the vehicle is imbedded in the soil, its cargo compartment body split open to reveal numerous large crates in a state of disarray. Surrounding the crashed vehicle, however, is a gruesome sight. What appears to be hundreds of decaying humans move listlessly about the field, seemingly ignorant of their surroundings. The smell of rotting meat and chemicals is thick in the air.

#### **NEW TECH: POWERED CESTA**

A powered cesta is a metal jai alai racquet resembling a curved scoop held in the right hand. Balls are captured in the grooved arch of the cesta then thrown overhand. The cesta's energy field accelerates the ball to almost 400 MPH.

**IRC: 7, WC: 6 Power: 1** Hydrogen cell (24 hours of power)

A powered cesta is designed to be used with a specialized jai alai ball (known as a *pelota*) manufactured from robust materials designed to endure the high velocity of the sport. If used with the powered cesta, a hurled pelota does 30 points of damage and has a 15% chance of knocking the target unconscious for 10-60 minutes. A powered cesta can be used to throw other spherical objects (grenades, mutated fruit, etc.). Doing so automatically triples the distance the object can be thrown and it inflicts 2d10 points of damage if it successfully hit its target due to sheer speed.



Occasionally, the ABE Foundry produces bad batches of artificial life that can't be recycled for fear they'd contaminate the organic stews from which ABEs are made. Before the catastrophe, these spoiled ABE could be repaired, but the means are now beyond Zeus. The A.I. simply has the faulty ABE units placed here and are forgotten. They slowly decay in this stadium, lacking even the most basic skill chips to motivate them.

**Decaying ABEs (200)** - AC: 8, Hit Points: 30 each, Movement in Spaces: 5, Radiation Resistance: 9, Constitution: 12, Mental Resistance: 6, Strength: 12, Dexterity: 9

**Appearance:** The flesh of these ABEs is in a state of chemical breakdown, making it resemble rotting skin and stinking of fetid meat and acrid chemicals. Most are in a state of undress, but a few are clothed in tattered uniforms or one-piece coveralls. Lacking bio chips, they move listlessly until something captures their attention.

**Normal Reaction and Attacking:** Decaying ABEs rudimentary bio-programming has been corrupted, turning them into irrational, primitive creatures. Their animalistic minds believe that by consuming living flesh their fake skin will be rejuvenated and they'll be restored to full functionality. Any living creature detected by the ABEs is targeted for consumption and the rotting artificial life forms will pursue their quarry for as long as they can. In small numbers, decaying ABEs are a minor danger. They bite their opponents in battle (WC 1, 1d6 dmg) and fully-armored targets are immune from this attack. When they swarm in herds, however, the decaying ABEs become far more dangerous (see below).

#### **Mutations or Defects:**

**HERD ASSEMBLY:** These creature instinctively work in concert to bring down prey, swarming opponents in large numbers. These herds contain 20 or more creatures. When in a herd, the decaying ABEs automatically hit any creature enveloped by their numbers, doing 3d12 points of damage unless the target is fully encased in metal or hard plastic armor. Additionally, targets caught up in the herd must roll their Strength or less on 5d6 if they wish to escape the teeming mass of grasping artificial life. Failure indicates they are pinned by the numerous creatures. Herds are immune to mental attacks unless the attack can affect every group member.

**POISON IMMUNITY:** Due to their artificial nature, ABEs are unaffected by poison of any type.

## OPTIONAL MUTATION INFECTION

The above encounter is obviously a nod to the "zombie apocalypse" genre that has become popular in various media. If the referee wishes to further emphasize this connection and tap into the zeitgeist of the gaming public, he can introduce this optional mutation to the decaying ABEs:

**INFECTION:** Any living creature bitten by a decaying ABE is potentially infected with a strange chemical wasting disease created by the rotting artificial flesh of the creature. This is treated as Intensity 14 poison. The creature takes additional damage normally if the result is a numeric entry, but becomes infected on a "D" result. Infected creatures lose 1 point of Strength, Dexterity, and Constitution (along with associated hit dice) each day it is infected. If any of these scores reach zero, the infected creature dies. However, the infected individual can stave off the ability loss by eating raw, living flesh. The flesh can be human, humanoid, animal, or mutant, but must be alive at the time of consumption. The infected individual must consume 30 hit points worth of flesh over a 24 hour period or he loses ability points.

This infection cannot be cured by first aid kits, but medical bots, the total healing mutation, and similar advanced medical treatments can neutralize the infection and save the creature's life.

**PHYSICAL REFLECTION (PARALYSIS DART, SLUG PROJECTORS):** The hard, rubbery flesh of ABEs resist paralysis darts and the rubber bullets of slug projectors, reflecting them randomly away if struck by such projectiles.

The crashed vehicle was a hover cargo transport similar to a panel truck. It was making automated deliveries throughout the stadiums when a malfunction caused it to crash here. The cargo remains intact, albeit surrounded by ravenous life forms who will attack anyone seeking to claim the crates.

## NEW TECH: GREENSCAR

**Power Source:** Atomic energy cell powers the vehicle for 72 hours of constant operation. The power cells are half-drained when the vehicle is first discovered.

**Description:** The Greenscar is a compact ground vehicle with room for two occupants (driver and passenger) protected by a metal roll cage. Small running boards and cargo platforms line the sides and rear of the vehicle, and can be used to transport up to 1,000 lbs. of material or passengers. The vehicle possess both four wheels and two treads for movement and can raise or lower the required motivator depending on terrain. Three semi-circular metal protrusions extend from the front and sides of the Greenscar, each covering the vehicle's mower blades.

**ICR: 7, AC: 6, Hit Points: 200**

**Weapons:** The Greenscar is not designed to be a weapon, but if a creature is somehow run over by the vehicle's mover blades, it is subject to a WC 6 attack that inflicts 20 points of damage. Mutant plants suffer double damage from the spinning blades.

There are a total of 25 refrigerator-sized metal and plastic cargo crates in the bed of the transport. These crates contain the following:

- 5 crates of sealed food packages intended for the stadium concession stands. Each crate holds 500 meals worth of non-perishable, tasty food.
- 10 crates of cleaned uniforms and sports gear. Each crate holds the equivalent of five suits of thin metal armor (AC 3) made from futuristic high density plastic and reinforced fibers. There are also a total of 200 colorful sports uniforms with no special properties (but see "Uniforms" note above).
- 2 crates of energy cells. Each crate contains 500 hydrogen cells, 100 solar cells, and 50 atomic cells. One crate also contains a water/hydrogen converter in a padded box.
- 5 crates each hold a disassembled standard general purpose bots. Assembling them is a Complexity 1 task. Their power cells are fully charged, however.

- 3 crates each contain 5 type 1 laser rifles. These boxes were meant for the android guards, but a computerized routing error placed them on this truck. The weapons lack energy cells but otherwise are in perfect condition.

## AREA 3C-1—GREENKEEPERS FACILITY

**The air tastes richer here and the smell of old cut grass lingers. This broad space is filled with creeping greenery that covers numerous indistinct shapes like small hummocks under a summer meadow. In the few clear places visible, complex looking machines on wheels and treads are parked, rusting silently beneath the stadium.**

This space served as an equipment garage and storage space for the Complex's greenkeepers, crewmembers tasked with maintaining the natural grass and plants used in the stadiums and buildings. The radiation cloud affected this space, triggering rampant grass growth and mutating the resulting mass.

Almost this entire area is occupied by a single creature: a sentient mass of mutated Kentucky bluegrass called dograss.

**Dograss (1)** - AC: n/a (always hits), Hit Points: 1000, Movement in Spaces: n/a, Radiation Resistance: 12, Constitution: 18 (6 vs herbicides), Mental Resistance: n/a, Strength: n/a, Dexterity: 12

**Appearance:** A titanic carpet of Kentucky bluegrass, the dograss covers this entire area with its lush carpet. The grassy tendrils seem to sway in a non-existent breeze.

**Normal Reaction and Attacking:** Dograss thrives on both artificial light and fresh blood. It gets the first from the lighting panels and the second from its spawn drones that attack prey and drag it back to its grassy expanse to feed the massive master. The dograss detects CO<sup>2</sup> in the air, spawning up to 10 drones to shed the blood of living creatures.

### **Mutations or Defects:**

**LIGHT DEPENDENT (D):** The dograss requires light to react to its surroundings. If ever plunged into total darkness, it becomes inert and incapable of attacking. In the event of a prolonged darkness lasting one week or more, the dograss dies from lack of light and dries out.

**SPAWN DRONES:** The mutant can spawn autonomous living creatures from its own body and command them to perform actions for its benefit. These drones resemble canines the size of mastiff hounds comprised entirely of interwoven grass. They have the following stats:



**Spawn Drone (10):** DEX 9; AC 5; HD 3; hp 12 each; YPM 6; #ATK 1; bite (WC 1; DMG 1d6); Mutations None; RR 12, MR 8, CON 12 (3 vs. herbicides), STR 9

Most of the objects overgrown by the dograss are a mixture of greens-keeping tools, chemicals, seed, and various other mundane landscaping equipment, now greatly degraded by age and the dograss. Two non-functional ecological garden bots are also here.

Three crates buried beneath the dograss remain intact, however. They contain one fully-powered force saw, a vibro-axe, and two sonic weedwackers (as vibro-machetes but with a 10' reach).

The complex-looking machines not covered by the dograss are three groundskeeper vehicles called Greenscars, combinations of mowers, golf carts, and Bobcat-style earthmovers. These Greenscars have been spared the ravages of time and still function, requiring a horticulture color band to operate.

## AREA 3C-2—UHWAYS VILLAGE

**An unusual sight is visible at the center of this stadium's playing field: a walled village fashioned from scavenged material. Rows of seats, packing containers, stray metal girders, and other debris is piled in a crude palisade surrounding cloth tents. The grassy playing field around the village bears a number of small gardens and middens, making it obvious these villagers have dwelled here for some time.**

Many years ago, a large band of true humans entered the Sports Complex in search of wonders and came into contact with Zeus. The A.I. made them the offer to "dwell in Olympus, forever," and they foolishly agreed. They've lived in this crude community ever since, provided for by Zeus, but regretting their decision. The tribe call themselves the "Uhways," after something they overheard at a sporting event.

The village has a population of around 200 with 85% being true human (the rest being a collection of refugee mutants who gained acceptance into the tribe). The Uhways have adapted to their new home down the years and considers the stadium and outside corridors to be their tribal lands. The villagers supplement their food and clothing provisions from Zeus with small gardens and via raiding parties that seek out food caches and supplies outside of their territory.

Over the years, the Uhways have come to believe that life is impossible outside of Olympus—perhaps as a coping mechanism to deal with their imprisonment—and it is taboo to speak of the "outer world." Outsiders who do are usually given as sacrifices to Zeus, stripped of their weapons, bound, and abandoned just outside of Uhways' lands. These unfortunates seldom survive long.

Explorers from elsewhere who keep their origins more discreet can find acceptance among the Uhways, giving them a safe refuge within the hazards of the Olympus Complex. To do so, they must prove themselves by completing a random Rite of Acceptance.

### TABLE 9-7: UHWAYS VILLAGE RITES OF ACCEPTANCE

#### D6 RITE OF ACCEPTANCE TO BE PERFORMED

- 1 Acquire a large (more than 14 days' worth) quantity of food, other than the concession stand fare Zeus provides the villagers, and give it to the Uhways.
- 2 Slay the Grassy Horror so that the villagers might plunder its lair (see area 3C-1).
- 3 Gain command of one of the Flying Eyes (camera drones controlled in area 4-3).
- 4 Provide the villagers with a gift of 2d6 artifacts in good working condition.
- 5 Bring the villagers an "Arm of Metal" to prove their valor (a bionic limb from the ABEs in area 2-4)
- 6 Tame one of the Beast Machines and bring it to the village as tribute (one of the demolition bots from area 3D-1).

PCs who complete their Rite are welcomed into the Uhways tribe as full members. They discover the tribe to possess few artifacts, but are well-armed with spears, bows, and clubs. Food is brought to the village daily by ABE units and androids. Life in the village is safe, but boring, and the unchanging diet leaves much to be desired.

**Average Uhways Villager** - AC: 7, Hit Points: 35, Movement in Spaces: 6, Radiation Resistance: 11, Constitution: 11, Mental Resistance: 12, Strength: 13, Dexterity: 13

**Appearance:** Usually a true human dressed in cast off sports uniforms and Olympus Complex coveralls. There is a 15% chance the villager is a mutated human with 1d4 random mutations.

**Normal Reaction and Attacking:** Suspicious of outsiders and regretting the choice to live in Olympus, an Uhways villager always keeps a sharp eye out for trouble. He sizes up strangers, believing them to be threats, and makes strange gestures and spits if they should mention the outside world. An Uhways villager is usually armed with a spear (WC 2, 1d6/1d4/1d6 dmg) or bow (WC 1, 1d6/1d6/1d6 dmg).

**Mutations or Defects:**

None

---

### AREA 3D-1—DEMOLITION BOT STADIUM PLAYING FIELD:

---

**The playing field of this stadium is comprised of hard-packed dirt, level but marked with what appears to be numerous tire and tread marks. Dark fluids stain the ground in places. With a rumble, two of the large field access doors open, revealing a dark corridor beyond. From out of the darkness roll tremendous, ominous-looking robots. Spikes, blades, flames, and the like cover their metal bodies, all of which show signs of damage.**

Bot Bash, a form of robot demolition derby, was a popular spectator sport prior to the catastrophe and Zeus continues to stage these matches even though attendance is way, way down. The characters have the misfortune of walking onto the field when one such match is scheduled.

**Demolition Bot (10)** - AC: 3, Hit Points: 250, Movement in Spaces: 60, Radiation Resistance: 14, Constitution: 15, Mental Resistance: 3, Strength: 3, Dexterity: 6

**Power System:** 72-hour battery pack

**Body Style:** Rectangular

**Motive System:** Wheels or treads

**Defensive Systems:** Metal plating

**Miscellaneous Systems:** Upper and lower light spectrum receivers including UV and IR ranges, self-aware tactics programs

**Weapon Systems:** Ramming attack (WC 2, 4d6 dmg), rotor-saws (WC 9, 30 dmg), plasma torches (WC 6, 3d12 damage), assorted blades, spikes, etc. (WC 3, 2d8 dmg).

**Appearance:** Demolition bots are hulking, tank-like robots standing 15' tall and measuring 20' long. They move about on either multiple, heavy tires or tank treads and bear manipulators armed with all manner of brutal melee weaponry. Several also have burning plasma torches or rotary saw blades to cut through opponent's armor.

**Normal Reaction and Attacking:** Demolition bots have two forms of programming: team vs. team and free for all. When operating under team vs. team protocols, they only attack bots on a rival team (teams usually consist of two sides of five bots each). In a free-for-all, everything is fair game. Determine a demo bot's target randomly and attack with every means possible! Demo bots have only rudimentary brains preprogrammed with tactical schemes, but can be controlled by a true human bearing a white or red color band if the would-be controller rolls his Leadership Potential or less on 4d6.

There is a 25% chance the demolition bots are playing a team vs. team match. In this case, PCs must simply avoid the fast moving demolition bots as they ram into one another should they wish to escape the field. Each PC must make 1d6 successful Dexterity checks, rolling 1d20 against their ability score to escape unharmed. A failed check indicates the PC gets in the way of a demolition bot and an attack roll is made against the character. PCs making all their checks reach the sidelines safely.

However, there is a 75% chance the match is a free for all, with the bots targeting anything on the field for destruction. The PCs are fair game in these bouts and may be randomly attacked by the crushing robots.

---

### AREA 3D-1—LAUNDRY:

---

**The stink of mildew and rot is heavy in the air here. Colonies of dark mold cover the surfaces of this entire cathedral-like area. A few dim lighting panels illuminate massive, mold-encrusted machinery and piles of decaying cloth. Large cylindrical containers line one wall with pools of stagnant water beneath them. Metal carts, likewise mold covered, are visible among the filth.**

This space was an industrial-sized laundry that handled the cleaning of the complex's uniforms, restaurant linens, and other cloth materials. The cosmic radiation affected the trace bacteria and mildew that accumulated here, creating a mold bloom that overwhelmed this and adjacent areas. The mold, while ominous looking, is non-hazardous.

The cylinders are 16' tall by 10' diameter and contain only dregs of industrial-sized detergents and other cleansers. The pool underneath their rusting legs is 1" deep and slightly sudsy. The water glows in the pres-

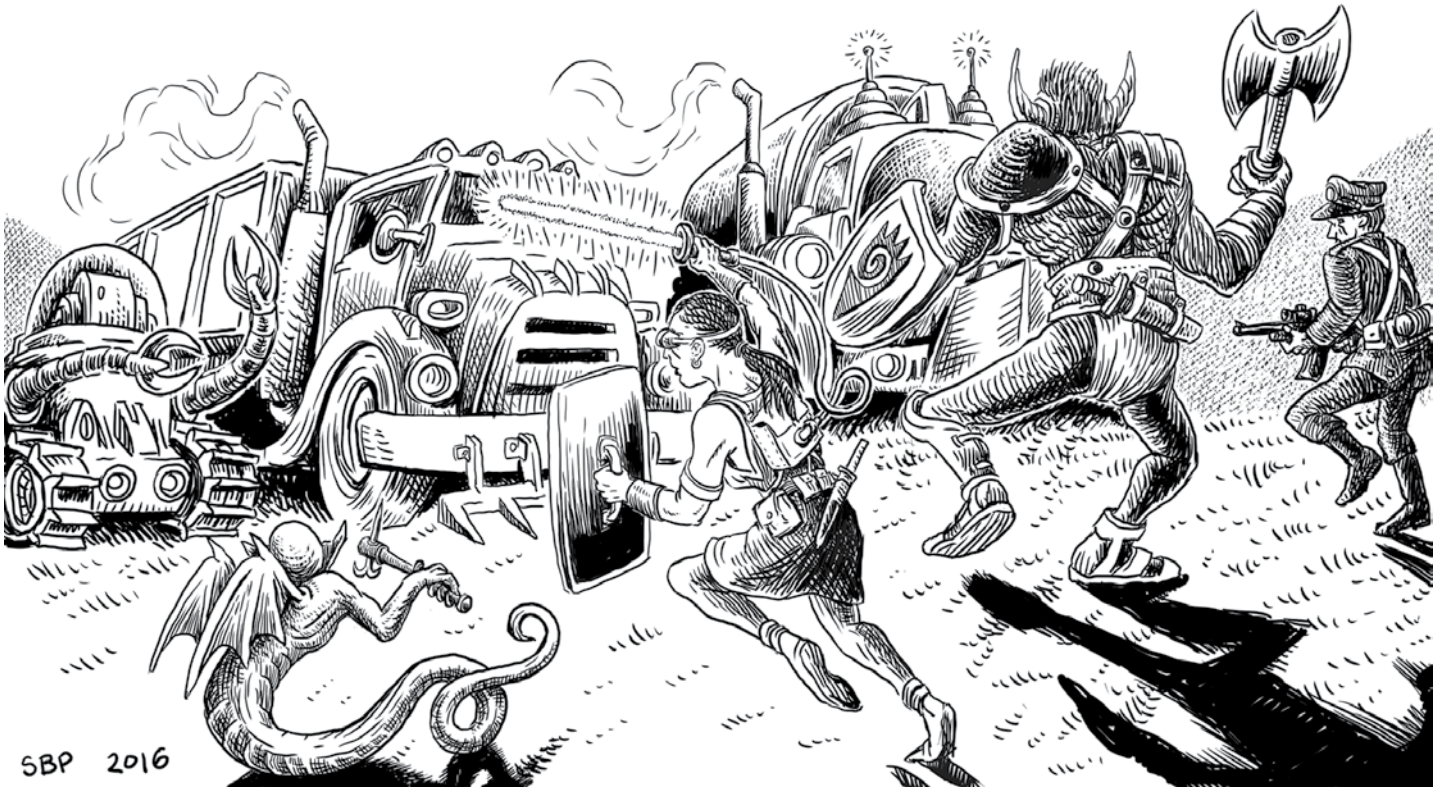

ence of Class 5 or stronger radiation and when within 10' of mutants possessing the *radiated eyes* mutation, making it possible to use as a jerry-rigged Geiger counter if collected.

### AREA 3E-1 – BASHBALL STADIUM PLAYING FIELD:

**The playing field at the center of this stadium is lined with dark dirt. Mismatched obstacles such as tall walls, wide raised platforms, crackling electrical towers, and spinning hoops are strewn about the field. What appear to be severed limbs encased in plastic plates lie forgotten in the dirt.**

Bashball was a popular sport that pitted rival teams dressed in plastic plate armor and short-distance jet packs against one another, employing dazzling aerobic maneuvers, martial arts, brute force, and overcoming playing field obstacles to put a cantaloupe-sized ball through spinning hoops.

The severed limbs are in fact discarded and damaged sections of bashball armor, high density plates with flexible joints that covers the arms and legs. There are seven armor sections comprising arm and leg armor. If two or more are worn by a creature, they reduce the wearer's AC by 1.

There is a 75% chance that a bashball game is scheduled while the PCs explore this area. If so, two ABE bashball teams dressed in bashball armor enter the field while the PCs are present. The teams' android coaches decide the PC would make a perfect warmup for the teams and sets the aerobic athletes against the party with instructions to show the intruders why the word "bash" is in the sport's name!

**Bashball Android Coach (2)** - AC: 3, Hit Points: 50, Movement in Spaces: 6, Radiation Resistance: 18, Constitution: 14, Mental Resistance: 16, Strength: 14, Dexterity: 14

**Appearance:** This android is dressed in bashball armor, a suit of plastic plate armor with opaque visor helmet. It is indistinguishable from the rest of the team members.

**Normal Reaction and Attacking:** Android coaches are programmed to guide their teams to victory and many take this programming too far, caring only for a spotless record. Some will cheat to win, while others arrange accidents to happen to promising opponents. In extreme measures, the android can attack with its fists (WC 2, 2d10 dmg), usually while shouting nonsensical phrases (insert your favorite sports chants here).

**Mutations or Defects:**

## BASHBALL ARMOR

Bashball armor is comprised of high density plastic plates affixed to a flexible body suit fashioned from a material somewhat like a hybrid of spandex and Kevlar. Due to the flexibility of this material, bashball armor can be worn by any humanoid-shaped creature between the heights of 5' 5" and 6' 5." The armor here is either red and white or black and gray.

**AC:** 3, **ICR:** 4, **Power:** 1 atomic energy cell provides 24 hours of constant use

A helmet with opaque faceplate accompanies the armor. This helmet is proof against heat and bullets, and protects the wearer from being blinded by bright lights. A HUD appears on the inside of the visor when the suit is activated, allowing the wearer to see normally, monitor the guidance systems, and activate armor's jump jets.

The suit amplifies the wearer's agility, granting the user the equivalent of the *heightened balance* mutations while the armor is powered. It also has a short distance jet propulsion system known as a jump jet. The jump jet allows the wearer to leap up to 50' vertically and 100' horizontally and land safely.

Due to the complexity of these systems, the armor's proper function must be determined with a successful roll vs. Complexity 4. Otherwise, the wearer only benefit from its defensive protection and cannot utilize its maneuverability augmentation.

When initially found, each suit has a half-charge left in its energy cell, allowing for 12 hours of operation.

**HEIGHTENED BALANCE:** While wearing the bashball armor, the android can maintain its balance in difficult situations, climbing walls with ease, walking tightropes, and performing other outstanding acrobatic feats.

**Artificial Biological Entity (ABE) - AC:** 3, Hit Points: 60 each, Movement in Spaces: 6, Radiation Resistance: 11, Constitution: 16, Mental Resistance: 18, Strength: 20, Dexterity: 16

**Normal Reaction and Attacking:** These ABEs follow their coaches' orders, intent on roughing up the PCs in the most dazzling aerobic manner possible. They fight unarmed, but their increased strength makes them fearsome opponents (WC 2; 4d6 damage). The bashball armor allows them to leap up to 100' horizontally and 50' vertically. They use this power to outmaneuver the PCs whenever possible.

### **Mutations or Defects:**

**POISON IMMUNITY:** Due to their artificial nature, ABEs are unaffected by poison of any type.

**PHYSICAL REFLECTION (PARALYSIS DART, SLUG PROJECTORS):** The hard, rubbery flesh of ABEs resist paralysis darts and the rubber bullets of slug projectors, reflecting them randomly away if struck by such projectiles.

**HEIGHTENED STRENGTH:** The ABEs were created with enhanced muscle-mass to dominate the bashball court. They add 3 dice to all damage rolls.

**HEIGHTENED BALANCE:** While wearing the bashball armor, the ABE can maintain its balance in difficult situations, climbing walls with ease, walking tightropes, and performing other outstanding acrobatic feats.

## AREA 3E-1 – BASHBALL STORAGE LOCKER

The doors to these areas are closed and sealed with a red color band lock. The doors are AC 2 and have 150 hit points if the PCs take the hard way to open them.

**Silent, unmoving armored forms line the walls of this room. Each stands upright inside a tight-fitting cubicle. A single lighting panel in each cubby shines down starkly on the plate-covered figures, their faces obscured by their helmet visors. A large closed box is also present near the far wall.**

Sports equipment for bashball games are stored here. Each of the figures is actually a suit of bashball armor held upright and complete on storage stands. There are 10 suits of bashball armor in total.

The box is unlocked and contains 20 bashball balls, cantaloupe-sized balls made from heavy rubber and knurled for easy gripping.

## AREA 3F-2—ZEEGEE STADIUM PLAYING FIELD

**This stadium is similar to the others found around the complex. High tiers of seating run down to the edges of a circular playing field in the center of the stadium. However, there appears to be an odd distortion in the air separating the seats and the playing field. A faint amber hue discolors the air. In the air beyond the amber glow, bits of sporting equipment and other debris float lazily in midair!**

Thanks to gravity generator technology, zero gravity sports became popular on earth even before the *Warden* departed on its doomed journey. A number of athletic competitions were adapted to null gravity conditions and several new sports were created to take advantage of weightlessness. This stadium was specifically designed to accommodate those contests.

An energy field contains the zero-gee conditions to the playing field while prohibiting attendees from entering. Treat it as a force field with 200 hit points should the PCs attempt to bring it down. Smaller, permeable energy fields exist at the playing field entrances on the lower level. These fields are weaker and can be walked through without difficulty, allowing players and other authorized individuals to take the field.

Inside the null gravity zone, the PCs have difficulty moving as the smallest exertion of force is enough to send them sailing into the air. Certain artifacts, mutations, and logical thinking can counteract this uncontrolled flight, and firing weapons or utilizing energy projection mutations can send the PC sailing in the opposite direction. Should the PCs resort to such measures, be sure to track their ammunition!

Mixed in with the floating debris are a trio of training orbs designed to improve athletes' coordination and speed by delivering low-power shocks to sluggish competitors. These orbs were affected by the radiation cloud and now pack a bigger punch.

**Training Orb (3)** - AC: 2, Hit Points: 40 each, Movement in Spaces: 75 flying, Radiation Resistance: 6, Constitution: 6, Mental Resistance: 3, Strength: 3, Dexterity: 15

**Power System:** Broadcast power

**Body Style:** Sphere

**Motive System:** Hover

**Defensive Systems:** None

**Miscellaneous Systems:** Optical receptors for normal, UV, and IR visual ranges, biological spectrometer, physical training programming package

**Weapon Systems:** Electric goad (WC 6, 5d6 dmg, 120' range).

**Appearance:** Training orbs resemble multifaceted metal spheres that move with grace through the air. Gleaming lenses track its target's location and crackle to life when firing a blast of white electricity at slugs.

**Normal Reaction:** The training orbs were programmed to instruct athletes with less than optimal physical traits and talents. As such, the orbs will never target creatures bearing Strength, Constitution, or Dexterity scores of 15+ or mutants with the heightened strength, heightened dexterity, or heightened balance mutations. Any other creature is fair game. The orbs target separate individuals if more than one meet the criteria of "training," but will turn all their attention to a single target if that is their only option.

Bringing the energy field down by causing damage is a bad idea. If the field falls, the null gravity generators fails dramatically, triggered a massive gravity implosion that causes immense damage to the stadium, uprooting seats, tearing the playing field to pieces, and partially collapsing the ceiling above. Every creature inside the stadium proper suffers 8d10 damage from the implosion. PCs floating inside the null-gravity field also plummet to the ground, taking an additional 1d6 damage for every 10' they fall.

The floating debris inside the field consists of a first aid kit, a pair of infra-red goggles, two baseball bats, a medical color band, and a box containing five hypodermic applicators. The applicator contains a single dose of performance-enhancing chemicals that grant the user the temporary benefits of the heightened strength, heightened dexterity, and heightened precision mutations. These benefits last for 2d4 hours.

## AREA 4: OPERATIONS HUB

This area is home to many of the Olympus Complex's main operations and support systems. It is the heart of the sprawling network of stadiums and home to the Zeus mainframe. It is a busy location, one filled with the Complex's largest threats.

### RANDOM ENCOUNTERS

Due to the heavy traffic through this area, random encounters occur on a roll of 2 in 6 and checks should be made every 30 minutes. If an encounter occurs, use the following table to determine what type of creature is met.

TABLE 9-8: OPERATIONS HUB  
RANDOM ENCOUNTER TABLE

| D10 | ENCOUNTER                                      |
|-----|--|
| 1   | IEE Event (see above and Appendix)             |
| 2   | 1 Security Bot (see area 4-2)                  |
| 3   | 1d3 Security Bot (see area 4-2)                |
| 4   | 1d4 Android Guards (see area 1-5)              |
| 5   | 1d6+1 Android Guards (see area 1-5)            |
| 6   | 2d4 Android Guards (see area 1-5)              |
| 7   | 2 Slaybots (see area 4-5)                      |
| 8   | 1 Standard General Purpose Robot (see MA p. 7) |
| 9   | 1 Standard General Purpose Robot (see MA p. 7) |
| 10  | Zeus in Solid Light Hologram Form (see above)  |

### GENERAL OPERATIONS HUB FEATURES

These following locations are present inside the hub, but have been left undeveloped and the referee is free to do with them as he desires. Some basic information is presented to get him started or to serve as a rough guide should the PCs enter the area before it is further fleshed out.

**Broadcast Power Generators:** Hulking machinery that create the power fields for the Complex. Weird energy fields throb through this area and sometimes affect robots, androids, or bionic-augmented creatures. Zeus cannot manifest or see into this area, making it a safe refuge for explorers.

**Maintenance Robot Berths:** Olympus is equipped with three hundred standard general purpose robots that act as the Complex's custodial staff. These bots are recharged and maintained here. Three hundred robot repair and recharging berths fill the rooms and bins containing a variety of robotic parts and supplies occupy the remaining available floor space. There are always 2d20 standard bots present here at any time.

**Office:** As elsewhere in Olympus, this section is a maze of offices and cubicles for the workers who oversaw the daily functions of the Sports & Entertainment Complex. They are dark and dusty, disused since the catastrophe. Some minor artifacts might be found here, but the area is otherwise unremarkable.

**Primary Medical Facility:** Better equipped than the medical center in area 2, this facility was designed to provide immediate, primary medical care to guests and staff in the event of an accident. The area is staffed by six medical bots that are currently powered down. A variety of medical supplies and artifacts are located here as well, ready loot for the first explorers that make it this far.

**Redundancy Databanks:** These large spaces contain numerous towering black blocks covered with blinking lights and spinning data tape reels. The temperature here is cooler than outside to help combat the heat created by these myriad databanks. The data towers are redundancy backups in case of catastrophic failure of Zeus' mainframe, allowing the A.I. to transfer its artificial intellect into these system's memory banks to avoid deletion. Destroying the Mainframe (area 4-7) will not defeat Zeus unless these databanks are also demolished.

**Slurry Tanks:** The gooey raw materials used to form the Complex's ABEs is stored here in large silos. Piping connects these reservoirs with the ABE foundry nearby. This area stinks of chemicals and meat, and is generally an unpleasant place to explore. Should the slurry containers break, a disgusting tide of horrible, liquefied flesh would flood this and nearby areas.

**Storage:** These massive, warehouse-size storage areas contains racks of shelving towering up to 40' high. A network of ceiling mounted cranes retrieve canisters from the various shelves, depositing them in open areas among the racks for easy loading onto gravity carts.

The majority of items in these rooms are ordinary goods such as paper supplies, blank data tapes, ball-

point pens, logbook tablets, cleaning supplies, etc., all in industrial-sized quantities. The referee can add more interesting/dangerous objects at his discretion.

**Transport Garages:** Dimly lit and dusty, these garages house row upon row of modified all-terrain vehicles used to transport staff throughout the complex and the surrounding grounds. Each garage holds twenty ATVs, each sporting the blue and gold Olympus Complex logo and name. Locked storage cages (requires gray color bands to open) hold 50 atomic cell batteries in each garage. Tools and 1d6 engineering bots are also present.

---

## AREA 4-1—SECURITY COMMAND

---

The door to this space is sealed and requires a security color band to open. Beyond it lies the following:

**This large area is strewn with raised platforms housing uncountable computer consoles. Hanging from the ceiling in clusters like metallic grapes are tri-d monitors. Some of the screens are dark, while other display unremarkable scenes of corridors, stadiums, and stores. An impressive vault door is inset in one wall.**

This command post oversaw all of Olympus Complex, monitoring the safety of visitors and staff. An efficient network of security cameras meant that there were few places within the facility that wasn't under the surveillance of the highly-trained security team. This surveillance systems is used by Zeus to good effect in the years after the catastrophe.

There are more than three hundred computer consoles and almost a thousand tri-d monitors in this space. Seventy-nine percent of them remain functional granting the same probability that a creature in this room can observe a desired portion of the sports complex. Zeus seldom interacts directly with these devices, but can kill security video feed to anyplace inside the facility if it desires.

Any failed attempts to utilize the computer consoles or open the vault door (see below), causes four security bots from area 4-2 to awaken and investigate this area. Unless commanded otherwise by an authorized operator, they demand the intruders depart, seeking to incapacitate them if they fail to comply.

A large vault door leads into the other half of this space and it requires either a military color band or

three security color bands to be used simultaneously to open the robust door. Beyond the door is the security arsenal containing the remaining weapons not issued to the android residents of the Complex. These weapons are stored in half-filled racks that contain 200 paralysis rods, 200 paralysis dart projectors, 100 gas ejectors, 75 slug projectors, 25 stun pistols, 15 type 1 laser pistols, 20 type 1 laser rifles, 5 bean bag pistols, 10 pepper pistols, and 3 tranquil-dart pistols.

Another smaller cubicle contains 1000 hydrogen cells, 5000 rounds of slug projector ammunition, 3000 gas pellets, 50 paralysis dart hand chargers, 500 bean bag rounds, and 500 tranquil-darts. A stack of footlocker-sized boxes contains a total of 1000 pepper grenades and 200 slippery grenades.

---

## AREA 4-2—SECURITY BOT BERTHS

---

**Floating, orb-shaped robot forms drift inside berths filling this space. Some of the near-man-sized orbs drift unsupported, while others are connected to various tubes, cords, and nozzles inside the metal cubbies.**

Olympus was equipped with 50 security bots to supplement its human staff. Some have been destroyed over the years, leaving 34 remaining. Half those bots are present here, recharging or awaiting orders.

**Security Bots (17)** - AC: 5, Hit Points: 50, Movement in Spaces: 75 flying, Radiation Resistance: 9, Constitution: 9, Mental Resistance: 9 Strength: 9 Dexterity: 15

**PowerSystem:** 72-hour battery pack

**Body Style:** Oval Shell

**Motive System:** Anti-grav Floating Pod

**Defensive Systems:** 100-point energy shields with thick armor plating.

**Miscellaneous Systems:** 2 long-range visual receptors (6 miles), sound receptors (range 295 feet), 72 hour battery pack, anti-grav propulsion, short wave radio circuit, and command and control systems for the takeover of other mechanical systems. Human Normal Sensor Package, Short Wave communication package, 1st & 2nd level computer package, human skills programming package.

**Weapon Systems:** 4 paralysis tentacles extending 13 feet, gas pellet ejector shooting Intensity 11 poison knock-out gas (3d6 hour duration), 2 third-stage slug projectors (2d6 subdual damage), 3 padded control ten-

# OLYMPUS COMPLEX

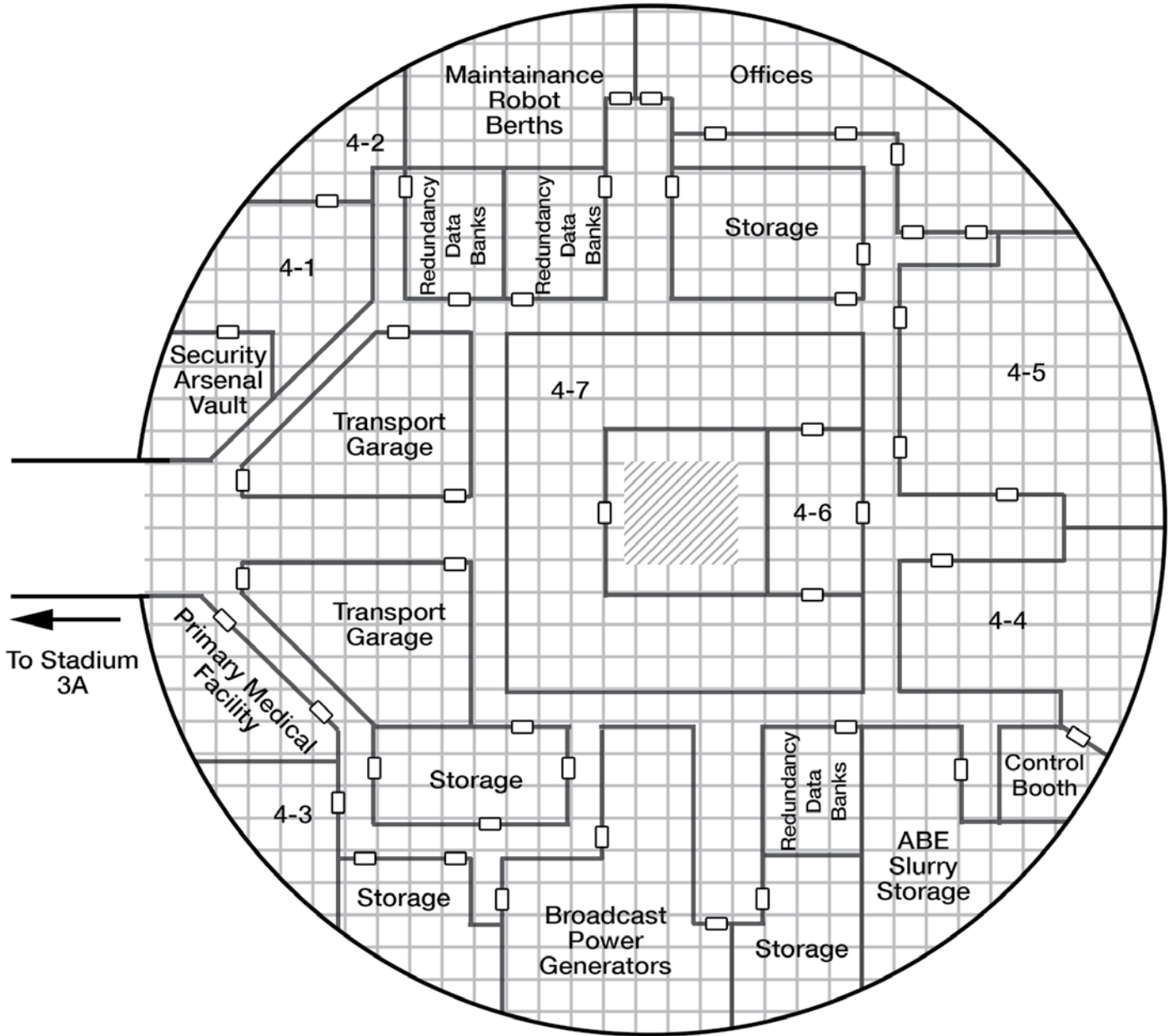

## OPERATIONS HUB Area 4

### Key

□ = 30'

▨ = Mainframe

□ = Door



tacles (damage as club); all weapon systems are WC 4.

**Appearance:** Security robots have egg-shaped bodies measuring 6' tall. Their metallic shells are shiny and usually featureless unless their tentacles or weaponry is extended for use.

**Normal Reaction:** The units awaken from sleep mode when this room is entered. They scan all creatures present, and if any creature presents a security color band, they go into standby mode unless given orders. The security robots automatically follow the commands of any true human with a security color band; they are 50% likely to obey mutated humanoids, and only 25% likely to obey mutated creatures. If no creature presents a security color band, 2d6 bots drift out of their berths and command the intruders to depart, escorting them from the installation.

Zeus can override the instructions of any outsider at any time and is cunning enough to use this power against intruders. The A.I. will allow invaders to assume command over the security bots, then revoke that control and turn the bots against their former masters at an opportune moment.

The berths are of no use to organic creatures, but robot PCs can insert themselves into a cubicle and regain 6d6 hit points. This process takes 1 hour to complete.

### AREA 4-3—CAMERA DRONE CONTROL BOOTH

**The ceiling of this room is a geodesic dome comprised of hexagon panels. Many of these panels are dark, but a few show tri-d images of green fields, furious sports action, or deserted hallways. The floor of the room holds numerous chairs and consoles atop low raised platforms.**

This room controlled the various camera drones that captured the action on the fields of Olympus' many stadiums. When Zeus took command of the installation, it usurped control of most of the drones and now employs them to its own ends. However, due to the cosmic radiation cloud and incidental damage throughout the complex, some drones are not under the A.I.'s control. An explorer who reaches this room and deduces the proper function of the control consoles could command a half-dozen camera drones.

Each of the octagonal panels is a tri-d screen. The dark screens represent camera drones under Zeus' control (their feed is now routed directly to the A.I.). The active screens are the feed from the uncontrolled cam-

era drones that continue their pre-programmed tasks. Understanding the consoles is a Complexity 2 task. Once the console's function is deduced, a successful use of a Complexity 3 device allows the operator to take control of one of the six active camera drones, directing them where he desires. Additional rolls are required to take control of more drones.

The drones can be programmed to fly a set of predetermined coordinates (a task requiring a Complexity 3 artifact check to properly program) or flown by a simple joystick control. When under manual control via the joystick, the referee might require the operator to roll against his Dexterity score to successfully operate the camera without incident or to perform any tricky aerobatic maneuvers.

The six "rogue" drones are currently at the following

#### **NEW TECH: CAMERA DRONE**

**Range:** Camera drones can operate up to 10 miles away from the complex, provided they find a way to exit the connected buildings.

**Power System:** The drone operates on broadcast power and also has a solar collection unit good for 5 hours of operation.

**Complexity:** 3

**Armor Class:** 5

**Description:** A camera drone measures 2' long and is kept aloft by four rotor propellers. It contains both visible light and infrared cameras with a 1 mile range and audio pickups good up to 500 feet. The drone is lightweight and has 15 hit points.

locations:

1. The Amusement Zone (area 1-5)
2. IEE Suite Entrance Atrium (area 2-1)
3. Retro Sports Playing Field (area 3A-1)
4. Decaying ABE Storage Playing Field (area 3B-2)
5. Demolition Bot Stadium Playing Field (area 3D-1)
6. Bashball Stadium Playing Field (area 3E-1)

Due to the damage suffered by the various systems of the Olympus Complex, it is likely that Zeus remains unaware that these rogue drones have fallen under someone else's control (the A.I. believes them destroyed). However, there is a 1 in 20 chance that the computer detects the unauthorized operator each time a camera drone is used. If the A.I. learns someone else is controlling the complex's aerial cameras, it dispatches a squad of 10 androids supported by a security bot to this area to deal with the interlopers.

---

### AREA 4-4—ABE FOUNDRY:

---

**Steam and heat hang in the air of this room, a titanic chamber filled with gleaming white machinery adorned with waving lights, flickering displays, and large reservoirs of blue liquid. There is a faint smell of antiseptic and a whiff of soon-to-spoil meat present. A large Plexiglas window separates the machinery area from an adjacent control room.**

The ABEs are manufactured and recycled in this room, fed into the machinery that molds the false flesh and support systems of the artificial life forms. Presses fill with a slurry of biological matter and then “cooked” until done, the final result emerging in a cloud of steam.

These machines are constantly active, creating or recycling the ABEs of the complex. It produces six ABE units each hour to replenish lost or injured units. Finished ABEs emerge from human-shaped modes into which the raw ABE materials are poured. Skill chips are installed soon after by the android overseers in the control room.

Non-functional ABEs are brought here for recycling as well, caught up by mechanical pinchers and dropped into a grinder that reduces them into slurry for later reuse. These pinchers are typically automated, but can be manually controlled from the adjacent control room.

There are four androids inside the operating booth, charged with running the foundry and installing skill chips in fresh ABEs.

**Android Controllers (4)** - AC: 6, Hit Points: 50, Movement in Spaces: 6, Radiation Resistance: 18, Constitution: 14, Mental Resistance: 16, Strength: 14, Dexterity: 14

**Appearance:** These androids are dressed in blue-white Olympus Complex coveralls. Their featureless faces stare blankly at intruders a moment before they

erupt in furious button pushing.

**Normal Reaction and Attacking:** The android controllers automatically notice intruders and demand to know their business via a PA system inside the control booth. Unless the PCs, can give an excellent reason, the androids consider them hostile. They respond by attacking with their personal weaponry or with the recycling claws on the main foundry floor. Each is equipped with a type 1 laser pistol (WC 6, 7d6 damage).

**Mutations or Defects:**

None

The recycling pinchers are WC 3 and on a successful strike they grab a PC, restraining them with a Strength of 20. The pinchers lift the unlucky victim up and deposit him in the recycling grinder on the following round, inflicting 10d6 points of damage. The target can escape this fate by rolling a 1d20 and adding its Strength score vs an opposed roll of the same by the referee.

The control booth consoles are Complexity 1, but if operated properly, can shut down the foundry. Damaging the controls (treat as AC 5 with 200 hit points) renders the foundry inoperable for 2d12 days while the damage is repaired. During that time, no new ABEs can be produced.

---

### AREA 4-5—SLAYBOT FACTORY:

---

**Thudding, clanging, and whirring resounds through this machine-filled area. Gargantuan engines and spinning robotic arms are manufacturing robotic parts and chassis, slowly assembling fearsome-looking mechanisms studded with weaponry. Rows of motionless robots, assembled but inactive, stand in formation in a parade ground space to the left of the manufacturing floor.**

Zeus knows it is only a matter of time before a concentrated assault is waged against the Complex, a prolonged siege his android and ABE defenders cannot repel. In preparation for that day, the A.I. has reprogrammed the machinery in this space to cease creating playbots and create a new breed of robot: the slaybot!

**Slaybots (50)** - AC: 3, Hit Points: 75, Movement in Spaces: 12, Radiation Resistance: 15, Constitution: 15, Mental Resistance: 7, Strength: 15, Dexterity: 15

**Power System:** Broadcast Power

**Body Style:** Humanoid

**Motive System:** Two legs

## AREA 4-6—MAINFRAME ANTECHAMBER:

**Defensive Systems:** Improvised armored plating

**Miscellaneous Systems:** Human Normal Sensor Package, Short Wave communication package, 1st & 2nd level computer package

**Weapon Systems:** Vibro-blade arms (4 attacks, WC 9, dmg 35); harpoon (WC 3, 1d12 dmg plus impaled); spike-thrower battery (WC 2, dmg 1d6×1d10, 20' square area)

**Appearance:** Slaybots are humanoid in appearance, possessing two legs and four arms tipped with whirring vibro-blades. Their torsos are covered in improvised armored plating crafted from scrap metal and sports padding. A compartmented box filled with spikes protrudes over their left shoulder and a pneumatic tube extends from its chest. Most slaybots still retain the black and white referee patterns of their playbot predecessors.

**Normal Reaction:** Slaybots are built to kill, intended to be thrown against enemies and tear them apart until the bot itself is destroyed. The bot usually begins combat by firing its spike-thrower battery, launching a barrage of 1' long javelins that attack all creatures in a 20' square area up to 600' away. A single attack roll is made against each creature in that area and, if successful, the target is struck by 1d6 spikes that inflict 1d10 damage each. The bot can only fire a spike volley once before it need reloading. Slaybots next close to within 50' of their targets and fire pneumatic-driven harpoons at their foes. If this attack strikes, the steel cable affixed to the harpoon is retracted at a rate of 25' per round until the target is brought into melee range and shredded with the slaybot's vibro-blade arms. The steel cable is AC 4 and has 50 hit points. Small secondary manipulators on each vibro-blade arm allow the bot to remove and reload the harpoon when necessary.

Slaybots are a special brand of robot and largely immune to control from color bands. Only a command ring will override the slaybots programming, wresting control of it from Zeus.

There are always fifty slaybots present here, although Zeus does dispatch patrols of them to test their efficiency against intruders. The factory can produce five slaybots each day to replace losses. The factory line can be sabotaged by inflicting 200+ points of damage to the various machinery (treat as AC 5, but taking only half-damage from non-powered attack). Attacking the machinery will automatically result in Zeus activating ALL the slaybots here to deal with intruders. If any of the stored bots are attacked, the A.I. activates 2d6 of them to slay the vandals.

**Dark computer consoles and silent, unmoving tri-d monitor screens are evident everywhere in this space. Scattered knots of artificial life are present here as clusters of faceless humanoid figures stand in watchful vigilance. Each of the dozen creatures is armed with technological devices. They snap into action as your presence is noticed, bringing the devices to bear in your direction!**

This space was formerly a computer monitoring station for the Zeus mainframe, but it now houses the A.I. final defenders, protecting the computer memory banks from intruders. Twelve androids are stationed here with orders to kill.

**Android Sentries (12)** - AC: 1, Hit Points: 70 each, Movement in Spaces: 6, Radiation Resistance: 18, Constitution: 17, Mental Resistance: 14, Strength: 17, Dexterity: 16

**Appearance:** These androids are dressed in blue and white coveralls bearing the Olympus Sports Complex logo and name. Each carries a laser pistol. A multi-pocketed belt encircles its waist.

**Normal Reaction and Attacking:** Unless told to stand down by Zeus, the androids attack to kill any creature entering this space. Each is equipped with a type 1 laser pistol (WC 6, 7d6+3d6 damage), a pepper grenade, and a vibro-blade (WC 9, 30+3d6 dmg) for close combat and gains a +4 bonus to its attack rolls. Their belts hold six hydrogen cells.

### **Mutations or Defects:**

**HEIGHTENED DEXTERITY:** When unencumbered by armor or heavy loads, the android has an AC 1.

**HEIGHTENED PRECISION:** The android can pinpoint weak points in an opponent's defenses, allowing it to deliver devastating blows. All successful attacks by the android add 2 additional damage dice.

**GENIUS (MILITARY):** The android's training in the combat arts grants it a +4 bonus to all attack rolls and adds an additional damage die to its attacks. This additional die is cumulative to the ones from its heightened precision mutation.

Aside from the androids' personal gear, there is little of value in this area. The doors to the mainframe (area 4-7) are sealed and require either a yellow programmer band or three engineering bands used simultaneously to bypass the door locks.

## AREA 4-7—MAINFRAME

**An opulent U-shaped chamber awaits you beyond the door. The floor displays a holographic sky filled with fluffy clouds underfoot as if you strode across the sky. White marble figures depicting beautiful males and females stand along the walls at regular intervals. Mixed among them are man-sized metal orbs that hover silently in the air.**

This area holds the Olympus mainframe and was designed to resemble the lofty heavens of the Greek gods. The statues are all of synthetic marble and depict various Greek gods, goddesses, and heroes. Mixed in with them are six upgraded security bots.

**Upgraded Security Bots (6)** - AC: 5, Hit Points: 250, Movement in Spaces: 75 flying, Radiation Resistance: 9, Constitution: 9, Mental Resistance: 9, Strength: 9, Dexterity: 15

**Power System:** 72-hour battery pack

**Body Style:** Oval Shell

**Motive System:** Anti-grav Floating Pod

**Miscellaneous Systems:** Human Normal Sensor Package, Short Wave communication package, 1st & 2nd level computer package, human skills programming package. 2 long-range visual receptors (6 miles), sound receptors (range 295 feet), 72 hour battery pack, anti-grav propulsion, short wave radio circuit, and command and control systems for the takeover of other mechanical systems.

**Defensive Systems:** 150 point energy shields with thick armor plating, rotating blades inflict 4d6 damage to any foe closing into melee range with the bot.

**Weapon Systems:** 4 paralysis tentacles extending 13 feet, gas pellet ejector shooting Intensity 11 poison knock-out gas (3d6 hour duration), 2 third-stage slug projectors (2d6 subdual damage), 3 padded control tentacles that discharge electrical blasts (15 damage); all weapon systems are WC 4.

**Appearance:** Security robots have egg-shaped bodies measuring 6' tall. Their metallic shells are shiny and usually featureless unless their tentacles or weaponry is extended for use.

**Normal Reaction and Attacking:** Unless Zeus instructs otherwise, these bots attack anyone entering this space.

Zeus can manifest itself in the room if it desires or the PCs are defeating its security bot guardians. When manifesting in this area, its electrical discharge attacks

inflict double damage and it heals 2d6 hit points each round if damaged.

The central mainframe is located behind a sealed door (yellow programmers color band or three engineering bands used simultaneously to open). It is gigantic cube seemingly formed from marble and bearing blinking lights and whirring data tape reels behind inset windows of transparasteel. It is AC 2 and has 400 hit points.

If the PCs attack the central mainframe and the redundant databanks are still intact, Zeus mocks them while continuing to summon his various guardian to stop them. It claims that "mere mortals cannot slay a god. Stop now and you'll receive my pardon. Otherwise, prepare for destruction!" It knows that even if they succeed the A.I. has refuges in the redundant databanks. If the PC do destroy the mainframe, Zeus flees to one of the backup databanks and begins plotting revenge, bringing all of Olympus' assets to bear against the party. Life should become very interesting for the PCs!

However, if the PCs have destroyed the backups and attack the mainframe, Zeus presents a much different face, pleading with them to stop and offering all manner of gifts from around Olympus if they do (the A.I. nevertheless continues to summon its defenders if any remain nearby). If the PCs agree to its demands, Zeus upholds its end of the bargain, giving them whatever they desire in exchange for its artificial life. It is grateful in its own odd way and pardons the PCs for their hubris. Zeus does politely ask them to take their rewards and depart, never to bother it again.

Destroying Zeus for good has both benefits and drawbacks. Lacking a central leader, the various ABE teams and androids soon fall into squabbling over territory and resources and civil war rocks Olympus. The IEE projectors are rendered inoperable without Zeus to command them against intruders. Wolfoids and other residents of Epsilon City quickly learn of the chaotic state of Olympus and seek to exploit it for their own gain. The PCs will have to work fast if they want to collect the best treasures awaiting discovery before rivals begin entering the Sports & Entertainment Complex in droves. Such is life aboard the *Warden*, inside the weird metropolis of Epsilon City!

## APPENDIX: IEE SCENARIOS

The PCs may succumb to the IEE projections of Zeus during their explorations or immerse themselves in these recreation simulations voluntarily via the mechanisms in area 2-2. The following are a list of potential Immersive Entertainment Experiences for the referee's use.

IEE projections occurring in the Complex's IEE suites are resolved as mental attacks from a Mental Resistance 18 source due to the specially-designed nature of the suites. Offensive projection triggered by Zeus elsewhere in Olympus are treated as originating from a Mental Resistance 12 attacker.

A PC suffering from an IEE projection can be roused from it by an unaffected ally shaking, slapping, or otherwise interrupting the hallucination. Doing so causes a new mental attack roll to be made against the PC. If it fails, the victim emerges from the hallucination. Each subsequent round an ally attempts to slap sense into the victim, the target's Mental Resistance is treated as if 1 point higher.

A victim suffering psychosomatic physical damage from an IEE projection heals half of it if successfully roused from the hallucination. If the PC dies from the damage before he is roused, his body dies from shock and he is considered truly dead.

Roll 1d6 on one of the following tables to determine the nature of the IEE projection depending on its source.



**TABLE 9-9: IEE SUITE PROJECTIONS**

**D6 IEE PROJECTION**

- 1 The target finds himself on a sunny beach, listening to the sounds of calypso music, enjoying tropical drinks, and surrounded by beautiful people. He indulges in swimming, water sports, and fine dining while the IEE lasts. He regains 3d6 hit points from the experience if injured.
- 2 The target is a dashing starship captain experiencing thrilling adventures on the edge of space. He defeats fearsome aliens, has dalliances with colorful alien species, and negotiates important treaties with powerful stellar empires. The target gains a +10% bonus to figuring out artifacts for the next 24 hours.
- 3 The target is a famous performer, actor, or entertainer enjoying all the benefits of a day in that life. He hob-nobs with the jet-set, drives fast vehicles, dines in the finest restaurants with the most glamorous guests, then caps the night off with a performance to a sold-out crowd. Treat his Constitution as if 1 point high for the purpose of resisting poisons for the next 24 hours.
- 4 The target is a master artist, renowned for his skill in his medium. He experiences the joys, sorrows, frustrations, and accolades of creating a masterpiece while under the effects of this projection. The target's Mental Resistance is treated as if 1 point higher for the next 24 hours as a result.
- 5 The target experiences an idyllic day, free from worries and cares, in the company of loved ones. Nothing extraordinary occurs during the projection, but the target emerges from it feeling relaxed and happy, glad to have had the experience. If true human, he can roll twice when attempting to recruit followers during the next 24 hours, taking the best result.
- 6 The target is the head of a megacorporation, fabulously wealthy and making decisions that affect the GNP of entire counties. He spends a day surrounded by flunkies, traveling in style, and lording over his holding like an emperor. He enjoys the benefits of the *genius (economic)* mental mutation for the next 24 hours after exiting the IEE projection.

**TABLE 9-10: OFFENSIVE IEE PROJECTIONS**

**D6 IEE PROJECTION**

- 1 A robot, bristling with weaponry, rounds a corner or appears through a doorway. It begins firing laser beams at the PCs, triggering another mental attack roll. If successful, the PC believes himself stuck and takes 6d6 points of psychosomatic damage. The hallucination continues until the target is slain or roused from its effects.
- 2 Warning klaxons sound as green radioactive sludge pours into the area from a ruptured conduit. All PCs suffering from the hallucination are subjected to Class 3d6 radiation. Roll separately for each affected individual. They continue to take damage so long as they remain in the area they believe contaminated.
- 3 The PCs' flesh seems to rot before his eyes, inflicting 1d6 points of psychosomatic damage each round he is under the influence of the IEE projection. The damage continues until he dies or is roused from the hallucination.
- 4 Hordes of androids ambush the PC, catching him in a withering crossfire of laser blasts. The victim automatically suffers 2d6 points of psychosomatic damage each round he experiences the projection. He cannot flee the ambush, and only rousing him from the IEE will save his life.
- 5 Poison gas floods into the PC's vicinity, exposing him to a random 3d6 Intensity poison. This possibly kills the victim outright. The damage, if any, is only suffered once before the gas appears to dissipate.
- 6 A hideous mutant, unlike anything the target has ever seen, seems to teleport to the PC's presence and attack with fearsome claws and teeth. The PC suffers 1d12 psychosomatic damage each round he believes the projection. He cannot flee the mutant, and only rousing him from the IEE will save his life.

# CAMELOT ENTERTAINMENT CENTRE

BY JAMES M. WARD

## CAMELOT PARK IN THE EARLY WARDEN

It is a historical fact that the Camelot Entertainment Center was the most used and enjoyed facility in the entire solar system around the time of the construction of the *Warden*. The Epsilon City section was designed first, as the ship levels were put together. Through this process, the Camelot Park opened as soon as power was acquired on the level. For years, people in and around the Transplutonian Shipyards came to the *Warden*'s Camelot Park to get away from it all and have a wonderful vacation, as the ship was completed around them.

Soon, the thrills and pleasures of the Camelot Center and news of its mental and physical healing properties spread throughout the system. At the time of the flight of the *Warden*, there were plans in motion to construct more of these types of entertainment centers. An especially complex one was scheduled for Earth's moon.

The day-to-day operation on the *Warden* version was simple. There was a full schedule of events and quests that were constantly carried out like clockwork out by its androids, holograms, and (now deceased) human employees. Human visitors could enter into any of the events and quests and experience them as visceral, intense encounters; the difficulty of these adventures varied according to the abilities and inclination of the participants. There was to be no actual danger for human participants, but the action was programmed to seem very dangerous. There was jousting at castle Camelot. Quests could be had where visitors followed android knights on adventures through the dark forest. Witches and dragons filled the area and were easily defeated.

## AFTER THE RADIATING OF THE WARDEN

After the ship went through the undetected radiation cloud, was an abrupt halt to humans coming to Camelot. The androids had no idea what to do. The human

staff of the complex had been completely wiped out. Appeals to the insane ship-level Artificial Intelligence controller got the facility nowhere as the A.I. had gone quite insane. Years later, radiation-poisoned, destructive robots started coming into the area. The powers of Merlin and his Druids were increased to deal with this danger. The facility's artificial intelligence also increased the combat skills of Camelot's androids and authorized them to use deadly force or dismantle artificial intruders.

After three hundred years, Camelot society continues, superficially the same, but there have been dramatic, often hidden, changes. Even so, all of the quests and other adventures are still possible in the park. All of these are far more dangerous than what was designed for harmless entertainment generations ago. Now, the dragons can actually eat the player characters. The android knights can cut off limbs with their swords. Jousting can take off the head of an unskilled visitor. As the quests get fulfilled, the dangers are replaced with more challenging quests and life grows a little harder for any visitor.

There are still tournaments at Camelot and quests to be had. These programmed events are vastly changed from the originals and far more deadly. Those who complete quests are still given boons and prizes fit for heroes. Humanoid mutants are considered members of Fairyland and allowed to compete. Humans, as always, are always welcomed into the castle (the A.I. understands that humans can be vandals or disruptive, but it is ill-equipped to respond to truly malevolent pure humans. That may be up to the PCs!). Animal mutants must be under the supervision of some type of humanoid as they have been classified by the A.I. as pets and helper animals. The paramount hated enemy of the entertainment center and its organized play became the wolfoids in all of their subspecies, who had become the dominant sentient life in Epsilon City, nearby. They became the "orcs" of Camelot and great fame is to be gained in fighting them and bringing back pelts.

The Camelot android vats are in constant operation; the A.I.'s number one priority, after all, is keeping the experience stable for visitors. Destroyed famous characters like King Arthur and Lancelot are reformed within a day and back in action. Destroyed dragons or questing beasts can appear over and over again, but if a character party destroys the same Knight or Dragon, that being or creature, after it is recreated, tends to stay away from that particular player group.

### GAMEMASTER'S NOTES

---

The player characters should have adventured several times before they come across the Camelot Entertainment Park. Imagine them as caveman-style mutants or highly techno-savvy beings. Regardless of their survival skills or technical knowledge, they are thrust into a medieval setting, where all of their hi-tech equipment, and even the clothes they wear, have been taken away from them. They must deal with the dangers presented by the legends that are Camelot and King Arthur's court using the tools provided to them. Nonetheless, there are highly useful treasures to be found here. The androids are programmed to allow the characters take whatever they find in the park out with them when they leave.

Note that most characters will have no idea that the park is an entertainment complex and that the vast majority of the characters here are androids acting out roles until they dig further.

The androids of the park attempt to interpret everyone and everything they interact with in the context of their programming. Discordant and completely unexpected occurrences may lead to random or illogical responses, though the A.I. by now has had centuries of freakish events to respond to and works very hard both to emulate 'reality' and keep the park functioning. Nothing else matters.

Park android will never willingly leave the park unless somehow the A.I. can be convinced it is necessary. The androids also never acknowledge the existence of the A.I. or that they are artificial beings. If necessary, the A.I. assumes direct control over its 'employees' to serve its goals.

Epsilon City describes several wolfoid tribes. Any one of these tribes could make a concerted effort to sack or occupy Camelot. Though the wolfoids sometimes invade Camelot en masse, they usually rampage and then leave with looted goods or interesting looking junk, rather than assailing the great keep or squatting on the grounds. Perhaps something has changed.

The Hun wolfoids may have the best opportunity to capture or do serious damage to Camelot, given their flying mounts, and any number of other tribes could take part (perhaps as allies) in a final assault on the androids and their fantasyland.

### WANDERING GROUPS

---

In Epsilon City, wolfoids of many types wander the streets and places of the city; they are the most common of the random encounters below. If the action is getting dull. Simply roll on the following table for a random encounter. If your players are doing too well, give them a bit of battle. Remember, however, that all of these encounters have the potential to give characters useful equipment.

**1 -- Pirate Wolfoid (4)** - AC:8, Hit Points:69, 66, 64, 61, Movement in Spaces:12, Radiation Resistance:18, Constitution:14, Mental Resistance:12, Strength:16, Dexterity:18

**Appearance:** Descended from the timber wolf, this mutation stands nine feet tall on its humanoid hind legs. It wears historical and colorful pirate garb. Armed with a large cutlass and several types of black powder weapons, this creature can be very dangerous. It is highly intelligent and well able to use the technology of the ship. Its front paws have mutated into grasping hands with long, razor sharp talons.

**Normal Reactions and Attacking:** Other Wolfoid groups tend to stay away from this class of creature. Its cutlass is Weapon Class 3, inflicting 1d12 +4 points of damage. Its various black powder guns are Weapon Class 5 doing 20 points a strike. These creatures will attempt to capture female opponents rather than killing them.

**Mutations or Defects:** MANIPULATIVE PAWS – allows the mutant to handle any human built device. REFLECTIVE FUR – Reflects all types of energy. CONTACT POISON RESISTANT – Its fur resists all the affects of contact poison. REGENERATION – This mutant regenerates 5 lost hit points per melee round RADIATED EYES – 14 intensity useable once per day



**2 -- Roman Wolfoid (6)** - AC:4, Hit Points:79, 76, 74, 71, 70, 66, Movement in Spaces:10, Radiation Resistance:12, Constitution:15, Mental Resistance:12, Strength:12, Dexterity:17

**Appearance:** They wear a garb typical of a Roman legionnaire. Their red cloaks gives a plus to armor class.

**Normal Reactions and Attacking:** A typical legionnaire throws a javelin (Weapon Class 4, inflicting 1d10+4 in damage). It has a spear for a first strike in melee combat (Weapon Class 2, inflicting 1d12 +4). It is capable of pulling its gladius (shortsword) (Weapon Class 2, strikes twice in a combat round, inflicting 1d10+4 in combat per strike).

These wolfoids will never attack anything that looks like a dog, wolf, or bear. They will retreat from such battles. The trick of attacking twice in a combat round with a gladius can be learned by characters after they use the weapon twice in combat.

**Mutations or Defects:** REFLECTIVE FUR – Fur resists laser and other energy attacks, FIRE VULNERABILITY – Fire attacks do double damage to these wolfoids, TELEPATHY – These wolfoids have telepathy with a 150-yard range

**3 – Egyptian Wolfoid (6)** - AC:3, Hit Points:77, 75, 71, 66, 61, 60, Movement in Spaces:12, Radiation Resistance:18, Constitution:17, Mental Resistance:16, Strength:15, Dexterity:14

**Appearance:** These nine-feet tall wolfoids have red ophidian flesh instead of fur on their bodies. They are dressed in ancient Egyptian leathers and their helmets look like the hood of a cobra. They are often seen riding on two wheeled chariots pulled by android horses.

**Normal Reactions and Attacking:** They use a special long bow in battle: as one wolfoid fires the bow, the other drives the chariot (Weapon class 1, inflicts 1d10 +4 points of damage). For melee they use a large shield (+1 bonus on armor class) and a long spear (Weapon class 2, inflicts 10 points of damage).

These wolfoids won't attack anything that remotely looks like a snake or reptile of any type. They love riding some distance away from foes and making long range attacks with their bows. The bow has a strong pull and can only be used by beings with a Strength of 16 or more.

**Mutations or Defects:** REFLECTIVE FUR – Their scales have kinetic absorption and stop the first 5 points of every kinetic attack. LIGHT ABSORPTION – Light absorption allows the mutant to gain 6 points of healing from every laser attack and be completely invulnerable to lasers or any light attacks

**4 – Viking Wolfoid (5)** - AC:3, Hit Points:49, 47, 46, 44, 41, Movement in Spaces:9, Radiation Resistance:12, Constitution:12, Mental Resistance:12, Strength:18, Dexterity:18

**Appearance:** These nine-feet tall wolfoids have red ophidian flesh instead of fur on their bodies. They are dressed in ancient Egyptian leathers and their helmets look like the hood of a cobra. They are often seen riding on two wheeled chariots pulled by android horses.

**Normal Reactions and Attacking:** They use a special long bow in battle: as one wolfoid fires the bow, the other drives the chariot (Weapon class 1, inflicts 1d10 +4 points of damage). For melee they use a large shield (+1 bonus on armor class) and a long spear (Weapon class 2, inflicts 10 points of damage).

These wolfoids won't attack anything that remotely looks like a snake or reptile of any type. They love riding some distance away from foes and making long range attacks with their bows. The bow has a strong pull and can only be used by beings with a Strength of 16 or more.

**Mutations or Defects:** REFLECTIVE FUR – Their scales have kinetic absorption and stop the first 5 points of every kinetic attack. LIGHT ABSORPTION – Light absorption allows the mutant to gain 6 points of healing from every laser attack and be completely invulnerable to lasers or any light attacks

**5 – Cherokee Wolfoid (4)** - AC:7, Hit Points:88, 85, 83, 80, Movement in Spaces:16, Radiation Resistance:10, Constitution:18, Mental Resistance:11, Strength:11 Dexterity:17

**Appearance:** These wolfoids wear the leathers and feathers of a Cherokee Indian. They wear war paint and most are seen riding huge quarter horses with palm prints of the owning wolfoid on its withers. They are eight feet tall, with the most humanoid features of all of the wolfoid clans. They enjoy the use of a large hide shield and are quite skilled at blocking melee blows with the shield.

**Normal Reactions and Attacking:** The wolfoid can hurl a lance up to 200 yards away (Weapon Class 1, inflicting 15 points of damage). Each horse carries a rack of 9 lances. In close combat the wolfoid uses a large club. Its strength isn't great, but the skill of the warrior gives a Weapon Class of 2, inflicting 12 points of damage a strike.

These mutants will not attack any feathered creature. However, they want feathers for their war bonnets and decorations on their weapons and shields. They make

every effort to capture feathered beings; take several feathers from them; and then set them free.

**Mutations or Defects:** SURE STRIKE – This mutant has a mutation that causes them to never miss with the first lance strike or spear strike, BEST DEFENSE – This mutation has the first strike from a foe always hit their shield, EQUINE COMMUNICATION – This mutant has a skill that allows them to instantly tame and communicate with any type of horse breed.

## 6 – Dead Wolfoid Group

This is a special chance for role-playing fun. The game master should take one of the wolfoid groups and destroy it for the player characters to find. .

**You see a pile of wolfoids with their dark blood splattered all over the deck.**

What has happened, these wolfoids had found a batch of force pistols and thought they had the weapons figured out. In truth the weapons were much more complex than the wolfoids knew. They fired the weapons at maximum power and blew their bodies inside out. When the player characters come upon the scene they can collect all of the normal equipment of the dead, as well as the small pistols (Weapon Class 5, 20 points of damage, at full attack each does 40 points, they turn to slag after the 10th shot). These weapons are throwaway and operate any way you want them to, but they should be hard to figure out. They are good for eight more shots and then become junk or spare parts with no chance of recharging. It's up to you figure exactly how the wolfoids made them malfunction so badly...

**7 – Sword Bush** - AC:6, Hit Points:49, Movement in Spaces:Special, Radiation Resistance:17, Constitution:12, Mental Resistance:16, Strength:16, Dexterity:10

**Appearance:** This appears as a large fern plant. Its fronds are hard and metallic.

**Normal Reactions and Attacking:** This plant will be teleporting into the area in striking distance of the backs of the character party. It has been known to use complex equipment, including weapons.

The bush teleports away after taking 25 or more points in damage.

**Mutations or Defects:** TELEPORTATIONINTELLIGENCEMENTAL CONTROLPRECOGNITIONBRANCH JAVELINS (WC 2, 14 javelins, 2d6 +4)10 SWORD FRONDS (WC 1, can use two swords in any direction, 3d6 damage each), **Defect:** IMMOBILE BY NIGHT

**8 – Metaled One (Badger) (3)** - AC:2, Hit Points:75, 74, 73, Movement in Spaces:10, Radiation Resistance:18, Constitution:18, Mental Resistance:18, Strength:18, Dexterity:10

**Appearance:** It's a humanoid creature standing 3 feet tall. Its fur has been changed into a crystal lattice that covers its body with the same colors as a normal badger. Its hands act as swords when it extends its talons (WC 2, inflicting 2d6 +4 per talon).

**Normal Reactions and Attacking:** The creatures are talkers, not fighters. However, they are also thieves and constantly plot to take the best piece of equipment from each of the characters they befriend.

**Mutations or Defects:** PARALYSIS, TELEKINESIS, **Defect:** NEARSIGHTED: It can't see very well over 20 yards **Defect:** FEAR OF MUTANT PLANTS: It runs in fear from all intelligent plants

**9 – Cougaroid (Cougar)** - Armor Class:5, Hit Points:60, Movement in Spaces:10, Radiation Resistance:11, Constitution:12, Mental Resistance:13, Strength:14, Dexterity:15

**Appearance:** It's a humanoid now, standing on its back legs. It still has the same coloring as a normal Cougar. It is usually found with several useful devices.

**Normal Reactions and Attacking:** The creature is constantly looking to team up with other groups. It offers knowledge on complex devices to pay for its way into the group. This random creature is loaded down with fragmentation grenades that it is happy to share (Weapon Class 4, inflicting 4d6 in damage, 24 in two small backpacks).

**Mutations or Defects:** RESISTANT TO LASERS, ELECTRICITY AND PARALYSIS, IMMUNE TO MENTAL ATTACK: Its brain is totally resistant to all forms of mental attack, MANIPULATIVE PAWS, HEIGHTENED INTELLIGENCE, **Defect:** ROBOT BLINDNESS: It can't see or hear robots of all types, **Defect:** ATTRACTION ODOR: Its attraction odor makes it a tasty smelling treat for all meat eaters

**10 – Jeget (2)** - AC:5, Hit Points:88, 82 Movement in Spaces:12, Radiation Resistance:18, Constitution:18, Mental Resistance:18, Strength:11, Dexterity:11

**Appearance:** This is a two-foot long jaguar walking on its hind legs. It is highly intelligent and can often be found with lots of ancient equipment.

**Normal Reactions and Attacking:** The creature uses an energy bolo weapon (Weapon Class 3, inflicting 30 points of stun damage). It doesn't mind talking

instead of attacking and is always interested in trading tech items.

**Mutations:** HEIGHTENED INTELLIGENCE, LEVITATION, TELEPATHY, PRECOGNITION, FEAR GENERATION, TELEKINESIS, FORCE FIELD GENERATION,

Defects: VULNERABLE TO POISON, FEAR REACTION TO MUTANT PLANTS, ATTRACTION ODOR

## CAMELOT, THE ENTERTAINMENT CENTER

The Camelot Entertainment Complex takes up a large artificial island centrally located in Epsilon City. Unlike the rest of the city it has not been overrun with wolfoid tribes, though it suffers from constant incursions by curious and avaricious groups of the lupine mutants.

The lake that borders the complex on the south (aft) is infested with mutated creatures and insane and dangerous artificial fantastic life original designed to grant passing thrills to tourists. The other sides of the complex are surrounded by a deep moat and a nano-tree forest, which blocks all but aerial access. To preserve verisimilitude, air taxis and other flying vehicles will not fly over or land in the complex unless they are manually overridden using a command, engineering, medical, or other non-brown band.

There are two bridge entrances on the starboard and port sides of the complex, and a single ferry to the

complex, which docks at two different locations: the Tourney Fields and Stonehenge at opposite ends of the island.

Some of the wolfoid tribes build rafts or attempt to repurpose air taxis to arrive at Camelot. The Hun wolfoids can use their pegasi to make raids.

From the city-side shores of the lake, Camelot Island resembles a forested hill. The turrets of the castle peek out from the nano-trees that hedge the complex, banners whipping in the artificial wind. Sustained observation reveals a dark, winged, tailed creature circling from time to time.

Nano-bot Great-tree forests surround the entertainment park. Each of these trees is several hundred yards tall and provides a hundred yard cover of branches and leaves. The leaves are constantly in a colorful fall look. The trees are so thick and close together that they act as a perfect barrier to the playground that is the Camelot area. As nano-bot-based structures these trees are impossible to cut down, their bark and wood regrowing as soon as a cut is made into them. Their fall colors were originally chosen to signify the joys of autumn and harvest festivals. The leaves over the length of the ship's year go through color changes from a soft brown to an amazing golden color. A number of flying creatures, including birds, flying squirrels, bats, and insects, have made their homes in the branches of the trees, all peaceful and well fed on the many tasty treats in the form of seeds and fruit that grow in the high cover.



## ENTRANCES

---

Breaking up these arboreal walls are four large entrances to the entertainment center. Each is designed to change the visitor into a Camelot character. They are staffed by androids.

When groups come to one of the entrances they are treated well. However, their equipment and clothing is completely stripped away and stored carefully. That equipment is given back when a character leaves from any exit (if the characters are leaving in a hurry, their equipment must be fetched from the entrance they were admitted to the park at). This is all explained to the characters and if they refuse, they are not allowed in the center. There are many brutal weapon emplacements hidden in the entrances that can blow away most highly armored characters. No vehicles of any type are allowed in the park; mounts of all types are allowed.

All character groups must have at least one humanoid with vaguely human features, or they will be turned back by the center's androids. A non-human humanoid character of this type is considered to be from the land of the fairies and allowed to enter after being given large fake wings to wear that actually allow them to fly, albeit only in the park (up to 100 feet up). All the other nonhumanoid characters that follow the one accepted character are considered pets of the accepted character. Robot pets are transformed by use of holograms into resembling some type of fantasy creature. These holograms only function in the park without interruption and for 24 hours afterwards out of the park when that robot leaves the area.

Pure Humans have it best at all at the entrances as they are treated as honored ladies and gentleman. Medical robots heal damaged humans arriving at the entrance in an instant. Broken equipment is repaired or recharged. They are given a Camelot band that opens special quests in the park (this is the same band that is used to keep track of 'pets'). They are dressed appropriately according to the entrance they arrived at.

### CAMELOT ENTRANCE #1

---

This entrance has a very Renaissance Faire style with all the androids dressed as courtly knights and ladies. There is constant music with dancing and many other entertainments. Tasty food (infused with medical nanites) is out on tables night and day and will instantly



heal any damaged character that takes part in the feast. There are hundreds of androids roaming around each of the areas trying to create an atmosphere of the Middle Ages. Lovely female androids flirt outrageously with the males of the group and male androids do the same with the player character females.

Sir Gawain comes to greet all characters that try to enter the park from the Camelot entrance. He sets up the story and allows the group to change into suitable clothes. He walks with the characters to Camelot castle where the characters are taken to one of the towers and entered into one of the comfortable hotel style rooms with a bath and large living room area. He prepares the group for a feast with King Arthur and the Queen. The player characters must agree to exchange their equipment and clothes for Camelot clothes and weapons, if they wish to enter the castle or quest in the entertainment center. Some characters may attempt to smuggle in hi-tech weaponry or equipment; if they succeed and are seen by the "staff" using these equipment the simulation grinds to a halt and they are ejected with protests of "bad form" and "ruining the experience for the guests".

**Sir Gawain (Android)** - AC:3, Hit Points:150  
Movement in Spaces:12, Radiation Resistance:12,  
Constitution:12, Mental Resistance:12, Strength:12,  
Dexterity:12

**Appearance:** This handsome knight is dressed in shiny plate mail. He stands seven feet tall. He's always smiling and happy. He wants to check the characters into the park, but they have to agree to give up their *Warden* ship equipment and armor.

**Normal Reaction:** The android comes out to greet the characters. He is there to test their reaction, and hails them in a mock-medieval manner. If they are aggressive he draws his long sword and fights very well (Weapon Class 3, 3d6+6 in damage). If the player characters begin a foolish battle more and more android Knights of the Round Table come to fight the characters until the player characters retreat or surrender. If the characters come back, after a day elapses there is a reset and Gawain comes out friendly as if nothing had happened.

If the characters act friendly, Gawain and many attractive serving wenches come out to re-clothe the characters in Camelot garb (princely robes). The characters are led to the feasting tables and Gawain eats with them and then takes them to the castle to be checked into wondrous suites.

1: Humans get asked their names and are from then on called Lord or Lady this or that according to the names they have given. Their clothes are replaced (and their old gear is stored at the entrance) with wondrous Camelot Clothes. A set of plate mail armor is prepared for those wanting to joust in the local tournament. An android pack horse is provided with each suit of armor. Each person is asked what type of melee weapon they would like. High quality swords, axes, maces, and the like are provided, one to a customer.

2: Humanoids are given a suit of crimson colored armor as they are supposed to take part in the challenges of Camelot. They are given an android pack horse for that armor. Otherwise they are given colored tabards with their choices of symbols on the tabards. Each fairy is asked what type of melee weapon they would like. High quality pole arms, two-handed hammers and axes, and the like are provided, one to a customer.

3: Pets are given a tabard with their owner's name. The owner is given an band and the pet is given a collar and both pet and owner know exactly where the other is in the park at all times, by concentrating and touching the band or collar.

4: Characters without some humanoid leader are shooed away from the entrance with a pyrotechnic display from one of the wizards or druids in attendance. If that doesn't scare away the creatures, laser emplacements blast away until the creatures or robots are dead. Many wolfoids are immune to laser blasts and packs of them often get into the park from one of the entrances.

5: Cyborg characters are difficult for the androids to comprehend. They usually strip them of all of their lose equipment and give them wizard's things and make them "junior" Merlins. A Merlin is given a wand that shoots a 30-point lightning bolt. After ten shots the wand must be exposed to the "sun" for an hour of recharging. Merlins also have special quests and can talk and order around fantasy creatures if they give that a try. The cyborg can use all of its equipment, and these capabilities are ignored by the androids of Camelot.

From this entrance characters are expected to go into the castle of Camelot. They may check into the area just like it was a luxury hotel, with their needs seen after by Sir Kay (a sarcastic and somewhat cowardly android) and two servant androids. This desk is always staffed, day and night. Servants may be summoned using bell pulls in the bedrooms. From their rooms they can enjoy the many features of Camelot.

**You have come to Castle Camelot. The castle is built of stone, plastered to shine white in the sun. Many towers and turrets rise and break up the great crenellated walls, which rise some 100 feet into the air. Vivid heraldic banners and pennons flutter from the roofs. When approach, you see in front of you there are hundreds of happy creatures and humans feasting at banquet tables. Spritely music is playing and the crowd seems to be really enjoying themselves in front of the castle walls. Sir Kay turns to you and gives a choice. You can come into Camelot and leave your worries and equipment behind or you can leave this area and the feast before of you.**

The great drawbridge and portcullis are lowered and opened, allowing you to ride right into the main bailey. From there the great hall, with huge windows of stained glass, is a short walk.

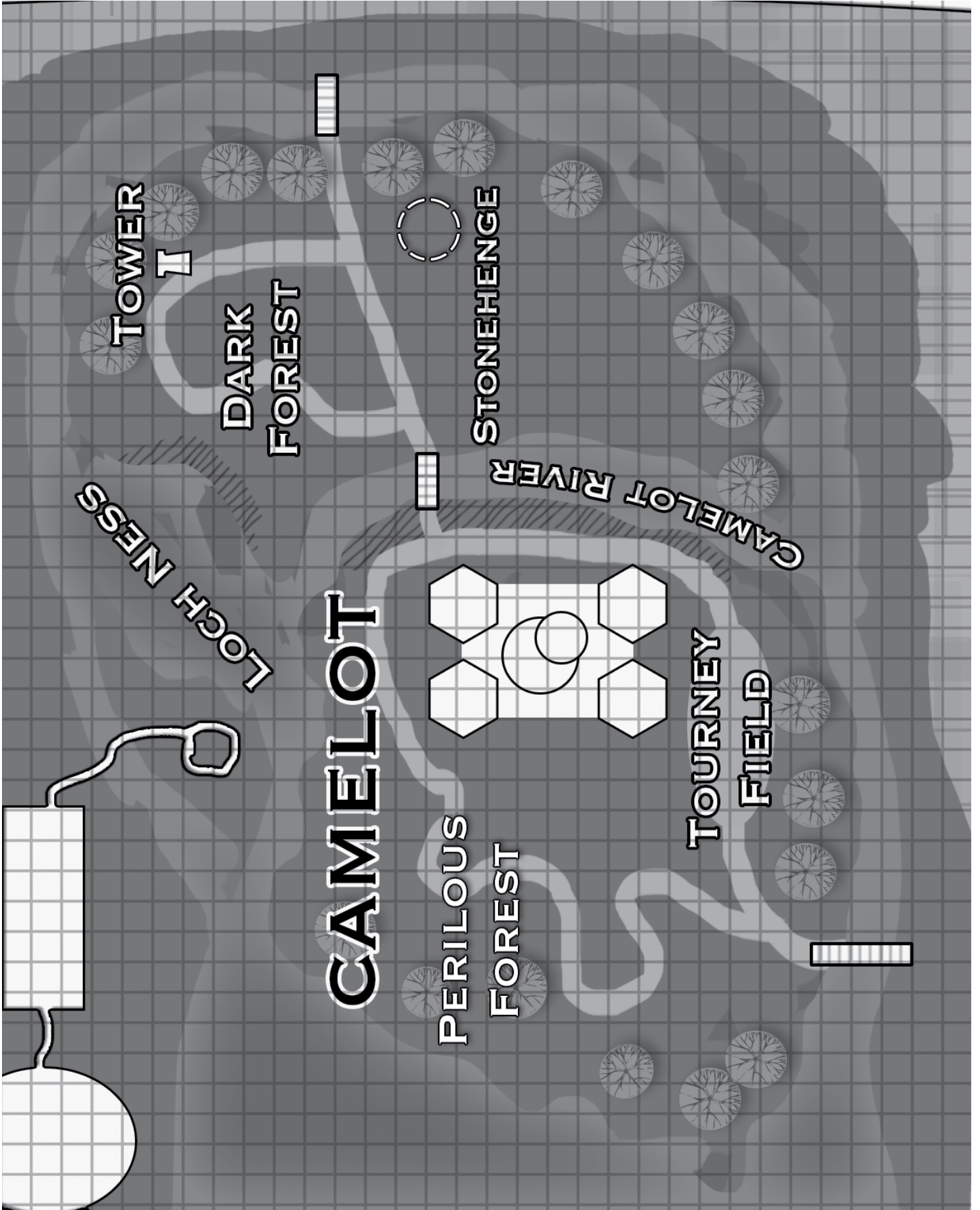

LOCH NESS

TOWER II

DARK FOREST

CAMELOT

PERILOUS FOREST

STONEHENGE

CAMELOT RIVER

TOURNEY FIELD

Inside Camelot itself there are several paths to adventure. Characters can take part in the grand joust or they can discover the mystery of where everyone goes at night. Characters are encouraged to leave the castle on horseback and adventure into the countryside. In the castle feast hall they hear about the witches' hovels and they hear about the questing beast. Both of these will sound like great good fun for questing.

Sir Kay is in charge of lost articles, accommodations, and problem-solving within the castle itself. Behind the 'front desk' of the hotel is a private office and storeroom, protected by a red security door (Kay wears a red security band under his robes). It is full of the personal effects of the humans killed in the disaster, including examples of every ordinary band (brown, green, white, red, and gray) in the *Warden*, expensive clothing, luggage, and gadgets (90% of which are broken). Kay is intelligent, but will not release these effects to PCs willingly unless commanded by his liege, King Arthur. Arthur and Kay will only acknowledge these anachronistic items if the complex is in severe danger. It may, however, be possible to break into the storeroom if Kay and his servants are distracted, though doing so requires either a red or golden band, or the captain's ring.

## CAMELOT ENTRANCE QUEST #1

### THE JOUSTING TOURNAMENT OF CHAMPIONS

Every day at high noon the jousting tournament begins. Knights from the Round Table joust each other from horseback for the glory of Camelot. These android knights have been doing this every day for all of their existences. They are experts at laying the lance into the body of their foes. If the characters don't practice in the practice lists behind the jousting stands they don't stand a chance, no matter what they roll.

For these jousts each humanoid character (never an animal nonhumanoid mutant or a robot) is given a suit of jousting armor with a kite shield, warhorse, and a lance in their proclaimed colors. If they are unhorsed during the tournament all of that equipment is given to the winner and they can't get more until the next day. The player characters taking part in the joust are also given an android squire that strongly recommends they take a day or two and practice in the practice lists behind the jousting stadium.

## PRACTICE LISTS

---

There are always 20-30 knights practicing on the lists at all times. The squire wants the characters to ride up and down each section of these practice lists for at least 20 times.

### RIDING

---

Warhorse riding is not a familiar action for most characters. In the practice lists the characters are encouraged to race their horse up and down a set of long corridors. As they get used to the motion of the horse they are given a long lance and encouraged to get used to holding it while they gallop.

### TAKING A BLOW

---

There are several ways to manage a blow. The practice field has large weighted sacks that the squires use to try and unhorse the practicing knights. Blows on the shield, chest, and even the head of the advancing knights are taken. Sometimes this unhorses the characters, but the practice field is covered in soft sand and the character never takes damage if they fall from their horse.

### AIMING A LANCE

---

A practicing knight begins by aiming at a large shield. If they don't hit the shield in the middle, (a roll of 9 or higher on 3d6) the shield remains firm and the lance breaks. The knight should strike five times in a row before they are judged sufficient in talent to go to the real lists. However, they can go whenever they wish, though their squire will insist they are not ready if they haven't accomplished this.

### THE REAL JOUST

---

Android knights are picked at random to joust with the player characters. Both groups roll three six sided dice and use the chart to decide a winner. If the player character is unhorsed, they lose all of their equipment and are given more the following day if they wish to joust some more. If the character unhorses an android they gain the equipment and the horse of that android. The captured material can be used in further jousts if the characters lose their original equipment.\

The characters ride against each other three times.

The winner is the one with the most points.

**Character Lance Breaks:** -1 to character's score

**Android Lance Breaks:** -2 against the android

**Android Shield Removed:** -3 against the android

**Character Unhorsed:** -5 against the player character

**Both Lances Break:** -1 against the android and -3 against the player character

**Character Helm Removed:** -3 against the player character

**Android Helm Removed:** -2 against the android

**Android Unhorsed:** -4 against the Android Character

Note the following:

- A If the character doesn't practice before the joust he or she will automatically be unhorsed every time he or she rides in a real tournament.
- B There are five superior android knights (name them as you will; if you have a copy of the *Morte d'Arthur* or *The Once and Future King*, open a page or two at random). Each of these is a great honor to battle. Each has a +5 on their total rolls. Defeating one of these gets all the characters sitting at the King's table.
- C All mutations that help in striking are added to the characters 3d6 rolls for a joust.

## WINNING

If a character wins two battles in a day, he is given a golden armband. This opens up one door of any type and then turns to dust.

## CAMELOT ENTRANCE QUEST #2:

### A NIGHT OF REVEALS

There are feasts every night in Castle Camelot. King Arthur and his queen mingle with the player characters and make them feel welcome in the castle. The player characters are encouraged to stay at Camelot as long as they wish.

The male and female androids act like normal lords and ladies. These characters can be romanced by the characters with no loss of honor on either side. Other knights present interesting things to do in the castle, such as games of backgammon or chess, gossip, run-ins with Morgan le Fay, Mordred or other villains (who never harm the characters or actually undertake any treachery).

Every night at midnight all of the androids claim they are going to bed and enter the android tower. In this tower the androids hook up to special power leads or are replaced as they expire after 365 days. Although the tower isn't guarded all of the doors to the various chambers are locked and it would take over 100 points of structural damage to break down one of the doors.

In the dungeons of this tower is a set of android vats and the characters can learn about the true nature of the characters of Camelot. Access to the android vats and the A.I. chamber is controlled by gray engineering bands. It is here that the Camelot A.I. is housed and can be spoken to directly. Also in the dungeons are fabrication machines that can give the characters fantastically powerful armor and medieval weapons capable of doing massive damage – if they are able to operate the devices correctly.

TABLE 10-1: JOUST RESULTS

| 3D6<br>ROLL OF THE<br>CHARACTER | DEFENSE OF THE ANDROID |                        |                          |                          |
|---------------------------------|------------------------|------------------------|--------------------------|--------------------------|
|                                 | 3-5                    | 6-9                    | 10-14                    | 15+                      |
| 3-5                             | Nothing Happens        | Nothing Happens        | Character's Lance breaks | Character unhorsed       |
| 6-9                             | Nothing Happens        | Android Shield Breaks  | Android's helm removed   | Character unhorsed       |
| 10-14                           | Android's Helm Removed | Android's lance breaks | Both Lances break        | Character unhorsed       |
| 15+                             | Android unhorsed       | Android unhorsed       | Both Lances break        | Character's helm removed |



## KING PELLINOR AND THE QUESTING BEAST: QUEST #3

The elderly yet rugged Pellinore may be encountered within Camelot. If engaged in conversation, he will ramble on at length about his quest and the questing beast, which he hunts with an obsessive fervor. Pellinore is, nonetheless, goodnatured and somewhat absent-minded.

**King Pellinor Android** - AC: 8, Hit Points:150  
Movement in Spaces: 14, Radiation Resistance: 18,  
Constitution:18, Mental Resistance:9, Strength:18,  
Dexterity:18.

**Appearance:** This seven foot tall android appears as an old man always dressed in old and rusty looking plate mail. His sword glows and does 40 points of damage at a strike because of the nanotechnology on its edge.

**Normal Reactions:** Pellinor goes out every morning at dawn and hunts the Questing Beast. He has a splendid collection of glowing fewmeats (beast poop) that he happily shows the characters. He would love to have some help in his hunt if the characters are interested. Catching the questing beast is extremely difficult as it is smarter than a normal human and moves faster than any creature on the ship. However, its android programming forces it to roam around Castle Camelot.

**Mutations and Defects:** None

**Questing Beast, Android** - AC:8, Hit Points:200  
Movement in Spaces:20, Radiation Resistance:18  
Constitution:18, Mental Resistance:18, Strength:18,  
Dexterity:18

**Appearance:** The questing beast is a composite of several different types of creatures. It has a long, serpentine, neck with the head of a unicorn. It has several different tentacles extending from its body with long unicorn horns at the end of the tentacles. Its main body is that of a large moose. Its eight legs are those of a crocodile with huge claws at the ends. There is a long scorpion tail with a poison stinger at the end. The creature stands ten feet tall and thirty feet long.

**Normal Reactions:** The beast loves being sighted and then runs quickly away from the group. If forced to melee it has several different types of attacks:

A It spews forth sleep gas that has a 1-50% chance of putting anything to sleep.

B Four different horns can attack four different targets for 30 points of damage each.

C Its claws can attack one foe on its left side and one on its right side for 35 points of claw damage.

D Upon taking more than 75 points of damage it has a painful roar that has a 1-75% chance of filling a foe with fear and causing them to drop their weapons and running away.

**Mutations (actually features of its design and the environmental settings):** MENTAL ATTACK RESISTANCE, RADIATION AND LASER BEAM RESISTANCE

Killing the beast and taking back its head brings great honor to the group. King Arthur gives each of the characters a “magical” sword that does 40 points of damage per successful strike, identical to that carried by the android Pellinore. A more advanced Questing Beast is created by the Camelot android vats within a month.

## GRAY KNIGHT ANDROID #4

The gray knight, who may be found riding along the roads outside Camelot, is programmed as an aggressive bully and purposely confronts the group and challenges one of the characters to a duel with abusive language. In the pre-disaster times this duel would never do more than bruising damage to the characters. Now, it is a fight to the death with the grey knight’s weapon doing a great deal of damage per strike.

**Gray Knight Bully Android** - AC:5, Movement in Spaces:10, Hit Points:55, Radiation Resistance:5, Constitution:5, Mental Resistance:5, Strength:10, Dexterity:5

**Appearance:** The android stands seven feet tall and is constantly dressed in grey armor. Although it looks and acts tough, it is a poltroon and a great coward.

**Normal Reactions:** Its chain sword weapon does 3d6 on a successful strike, WC3. It fights until it has taken 15 points of damage and then it yields and the characters never see it again. Victorious PCs will gain possession of its android horse, armor, and weapon.

**Mutations and Defects:** None

## FOREST OF MYSTERY: ENTRANCE #2

**Ominous music plays in the depths of this forest section. A lone rider gallops up into view, wearing black plate mail armor and riding a huge warhorse. He motions toward an animal trail and your choice is go down the trail or go back the way you came.**

The Forest of Mystery appears to be a sinister, dark wood. There will be at least two random encounters in this area, if they choose to enter.

**Black Knight Android** - AC:2, Hit Points:150, Movement in Spaces:12, Radiation Resistance:13, Constitution:13, Mental Resistance:13, Strength:19, Dexterity:13

**Mutations:** None

**Appearance:** The black knight android is there to introduce this section of the park to characters arriving at this entrance. A cloud of mystery and darkness is supposed to unnerve the characters. He doesn't want to talk unless he is forced to. His horse is huge with blazing red eyes and the smell of blood on its hairy hooves. He is wearing bulky black armor that seems to indicate he has massive muscles. The sword on his back is massive and at least eight feet long.

**Normal Reactions:** The knight only allows them to walk to the pavilion where he indicates that they must change their clothes into rich Camelot clothes and armor. There are android warhorses stabled in another section of the tent. These android horses are intelligent and want to help the characters. He uses gestures to convey his meanings, but feel free as the Gamemaster just talk them out for your players: The sword is WC4, does 25 points per strike, and only a character with a Strength of 19 can hope to use the weapon.

**“The knight gestures for you to change your clothes with ones in the tent.”**

**“The knight gestures for you to leave all of your equipment in the tent.”**

**“The knight gestures that you should take the right or left path out of the tent.”**

1: Humans get state their names and are from then on called Lord or Lady this or that according to the names they have given, by all other inhabitants of the forest. Their clothes are replaced with wondrous Camelot Clothes. A set of plate mail armor is prepared for those wanting to joust in the local tournament. An android packhorse is provided with each

suit of armor. Each person is asked what type of melee weapon they would like. High quality swords, axes, maces, and the like are provided, one to a customer.

- 2: Humanoids are given a suit of armor as they are supposed to take part in the challenges of Camelot. They are given a pack horse for that armor. Otherwise they are given colored tabards with their choices of symbols on the tabards. Each fairy is asked what type of melee weapon they would like. High quality pole arms, two handed hammers and axes, and the like are provided one to a customer.
- 3: Pets are given a tabard with their owner's name. The owner is given an band and the pet is given a collar and both pet and owner know exactly where the other is in the park at all times.
- 4: Characters without some humanoid leader are shooed away with a pyrotechnic display from one of the wizards or druids in attendance. If that doesn't scare away the creature, laser emplacements blast away until the creatures or robots are dead. Wolfoids are immune to laser blasts and packs of them often get into the park from one of the entrances.
- 5: Cyborg characters are difficult for the androids to deal with. They usually strip them of all of their lose equipment and give them wizard's things and make them junior Merlins. A Merlin is given a wand that shoots a 30 point lightning bolt. After ten shots the wand tries to open itself to the sun for an hour of recharging. Merlin's also have special quests and can talk and order around fantasy creatures if they give that a try. The cyborg can use all of its equipment, and those powers are ignored by the androids of Camelot.

## MYSTERIOUS FOREST QUEST B – THE CHALLENGE OF THE GREEN KNIGHT

**Green Knight** - AC:8, Hit Points:Special, Movement in Spaces:14, Radiation Resistance:18, Constitution:18, Mental Resistance:18, Strength:18, Dexterity:18

**Appearance:** It stands seven feet tall in glowing green plate mail armor. Its movements are swifter than a humans and its sword is a massive eight feet long weapon that it uses with one hand.

**Normal Reactions:** This android is positioned as the unbeatable foe. There is little that can harm it. It pre-

sents a threat and then it wants to force player characters to yield. When they yield it orders them to quest and bring back five wolfoid skulls each. If they don't yield in a battle the android is not allowed to kill them. It orders them to go and never look on him again. The sword does 15 points a strike in the hands of the green knight, but is too heavy for any other character.

**Mutations and Design Features:** IMMUNE TO ALL MUTATIONS, IMMUNE TO ALL ENERGY WEAPONS, KINETICALLY IMMUNE TO ALL BLOWS

The forest area is to be presented as dangerous and disturbing. All of the natural creatures of this part of the forest are larger than normal, from the foot-long ants to the five-foot long birds and foxes. Thirty-foot long snakes are common in this area. These are androids, not truly living creatures and won't attack anyone unless the A.I. deems them a threat.

The forest also contains a graveyard in a clearing where the androids inter visitors who have died, marked with wooden grave markers painted with the names they have given on entrance. There are quite a few, and many are now illegible, dating back to the cataclysm itself, 300 years ago.

### STONEHENGE: ENTRANCE #3

The "Stonehenge" is a round, rustic-style hotel where the chambers are all made of stone materials. There are a hundred suites all around a reconstruction of the historic Stonehenge, where tables are set up for banqueting. Male and female android, druids, friars and nuns roam the area and are there for the entertainment of the visiting guests. These androids are flirtatious or garrulous and want to become companions of the visitors while they are in the park.

Each of the suites, which are built into the rising ground surrounding the megalithic monument, is a study in luxury with a fancy bedroom and bath, with round the clock movies on a big screen monitor, with a computer designed to answer the questions about middle ages life, and a kitchen delivering amazing meals any time someone wants food and drink.

The android friars also supply a wondrous Celtic style festival with games, dancing, and fine food. Their "leader" and the welcomer is Friar Tuck, a portly, jovial android with a priest's tonsure and a thick brown robe. He wears simple sandals and a broad smile graces his face.

**Friar Tuck** - AC:3, Hit Points:150, Movement in Spaces:12, Radiation Resistance:12, Constitution:12, Mental Resistance:12, Strength:12 Dexterity:12

**Appearance:** The android friar is dressed in brown monk's robes and under those robes is strong chain mail. He has a long sword on one hip and a large flask of wine on the other hip. He's wearing a steel cap. Standing seven feet tall, he comes upon the characters with a friendly smile.

**Normal Reaction:** Tuck is there to explain things to the tourists/characters. He presents a bluff and friendly manner unless the characters get aggressive. If the characters foolishly attack, the friar is reinforced by more monks and hidden laser emplacements that blow away the characters.

Friendly characters are welcomed to the area and given a wonderful suite of stone apartments that surround Stonehenge, which stands on the hill atop them. The good friar is happy to show how things work in the suites from television screens to bathroom fixtures. The friar invites the group to feast in Stonehenge where the characters will learn more about the two Hinge quests.

The music of this area is somber and monastery-like. Android monks with quarterstaves work this area. There are tables of food and fantastic wines and ales being served here. All who come here are told of two quests that the monks need help with. For the service of working on the quest the monks give the characters "monk" equipment. They insist the characters strip and each type of character receives the following:

- 1: Humans get asked their names and are from then on called Bishop, Druid, or Abbess according to the names they have given and personalities. Their clothes are replaced with wondrous Camelot Clothes, styled like the warm and comfortable habits and robes of the holy androids. The men get a suit of chain mail that is unusually light and strong while the ladies get a cloak that is totally resistance to radiation and energy attacks of all types. An android packhorse is provided with each suit of armor. Each person is asked what type of missile weapon they would like. High quality bows, crossbows, javelins, and bolos are provided one to a customer.
- 2: Humanoids are given a suit of purple ring mail armor as they are supposed to take part in the challenges of Camelot. They are given an android packhorse for that armor. Otherwise they are given colored tabards with their choices of symbols on the tabards. Each fairy is asked what type of melee weapon they

would like. High quality pole arms, two-handed hammers and axes, and the like are provided one to a customer.

- 3: Pets (mutant creatures that aren't humanoid are assumed to be owned by the humanoids in the group) are given a tabard with their owner's name. The owner is given an band and the pet is given a collar and both pet and owner know exactly where the other is in the park at all times.
- 4: Characters without some humanoid leader are shooed away with a pyrotechnic display from one of the wizards or druids in attendance. If that doesn't scare away the creature, laser emplacements blast away until the creatures or robots are dead. Many wolfoids are immune to laser blasts and packs of them often get into the park from one of the entrances.
- 5: Cyborg characters are difficult for the androids to deal with. They usually strip them of all of their lose equipment and give them wizard's things and make them "junior" Merlins. A Merlin is given a wand that shoots a 30-point lightning bolt. After ten shots the wand tries to open itself to the sun for an hour of recharging. Merlin's also have special quests and can talk and order around fantasy creatures if they give that a try. The cyborg can use all of its equipment, and those powers are ignored by the androids of Camelot.

Stonehenge is a place for healing. The atmosphere of the area heals 5 points of damage a day. The food given to the guests of Stone Hinge heal 5 points a day. There are a hundred large stone suites for guests. These stone apartments surround Stonehenge. The android druids and clergy of the area are contemplative and offer to lead characters in meditation or prayer.

## STONGEHENGE QUEST D

### THE OGRE'S TOWER

---

The druids want the characters to relax and rest at Stonehenge; however they do talk a lot about the terrible ogre. It seems this creature comes and attacks at the beginning of every week. It arrives and grabs one of the large sarsen stones and walks away. All of the attacks of the druids bounce off the flesh of the monster. The druids freely share what they know about the monster and the large tower the creature is building in

the heart of the forest. From these conversations the characters can find out exactly how to get to the tower if they wish to take on the monster.

**Android Ogre** - AC:4, Hit Points:200, Movement in Spaces:14, Radiation Resistance:11, Constitutions:11, Mental Resistance:11 Strength:18 Dexterity:11

**Appearance:** This is a 12-foot-tall humanoid with massive muscles. He wears thick black furs. He has a dull look to his face. When attacked he goes into a rage that doesn't end until the battle is over. He runs away when his points fall below 101.

**Normal Reactions:** He strikes with a fist for 25 points of damage. He's building a tower out of the sarsens he steals from Stonehenge with the first and second floors finished. The third floor is half done. The cracks between the stones are filled with dried clay.

**Mutations and Defects:** IMMUNE TO ENERGY ATTACKS

### OGRE'S TOWER

---

This is a crude three story tall structure with three large chambers, one to each floor. The bottom floor is a kitchen and eating area with a fire smoldering constantly in the fireplace. There are several cow-like creatures cooking on spits. There are several barrels of crude wine. Furs and skins cover the walls and floors.

### SECOND FLOOR

---

This area is filled with equipment of all types native to the Camelot entertainment area. The ogre is studying this material and really can't figure anything out; some have technological capabilities while others are just set dressing. One of the functional pieces is a wand that shoots fireballs doing 40 points of damage. It charges with sunlight and fires nine times before needing recharging. There is also a set of three poisonous potions with skulls on the outside of each bottle. There are several chests filled with different colors of plastic domars. There is no way to spend this wealth in the Camelot area. The chamber also has some sort of fur-lined nest where the creature is clearly sleeping.

### THIRD FLOOR

---

Half of the walls are unfinished in this area. There is nothing but empty space in the area.

## STONEHENGE QUEST E

### THE TERRIBLE WITCH OF THE SWAMP

This is a hologram experience. Along the forest path is a small hut set against a hill. A four-foot tall elderly-looking old lady is sweeping the porch of the hut. She notices the group and begins laughing for some strange reason. The group can approach the hut or easily walk around it and continue down the path.

The group notices a small wooden hut set beside a large hill. The walls of the hut are made of rough wood and there are several wolfoid hides stretched out on the

walls. There is an old lady sweeping the front porch of the hut. She stands up and sees you all. She immediately starts cackling. You see nothing funny. She is motioning you over. Do you go to the hut or hurry around and continue down the path?

The witch is a hologram and designed to taunt and anger the group. She entices them into her hut and tries to feed them a tea that ruins their day with bowel complaints and they are forced to defecate all day long (when there is no bathroom in the forest). Observant characters may notice that the back of the hut opens into the hill and a rough-hewn passage leads deeper into the ground, shrouded in darkness. This leads into the cave and valley of the Red Dragon.



The computer program that runs the witch is trying to deliberately antagonize the party. Any weapons used against her bounce off force fields built into the hologram. Eventually she runs into the darkness at the back of her hut. The passage leads into a large cavern where the lava fires glow brightly and they will meet the red dragon Denzil.

This monstrosity, another hologram, is 90 yards long by 30 yards wide. Denzil is a winged and scaly red-colored dragon.

If the characters try to fight the dragon, force field systems buffet them with 10 points of damage a combat round. The damage seems to come from the wings of the dragon. It does not deliberately use its fiery breath against visitors. Nothing the characters do can hurt the dragon. It will stay and battle the characters until they are all dead. If they retreat the dragon crashes through the walls of the cavern and hut and rises into the air, circling for many hours, breathing fire down on the forest.

For the next four days it often hovers over the heads of the characters and burns down a forest area around them (remaining in the burning woods is foolhardy and possibly deadly). The people in the areas of the park complain bitterly about people who wake up dragons. Only Merlin in Camelot can drive off the dragon as it attacks Camelot. If the characters leave the park within these four days the dragon enters the city and burns large sections of that area.

## VALLEY OF THE RED DRAGON

---

There are no real red dragons in all of the levels of the *Warden*. However, there are holographic dragons that are as real as the insane artificial intelligences can make them. Denzil is an example of this kind of projection. In the dragon's valley the area is a burnt forest with burnt stumps of trees and lots of cracked rocks from fire damage. At the center of this little vale is a cave mouth.

As the characters come within a hundred yards of the cave, the holographic dragon rushes out and roars. Force fields make it seem like the characters can feel the thuds of the creature's claws. Sound waves have the characters feel the titanic roar of the dragon. The temperature rises twenty degrees in the area around the dragon. The image is perfect as the dragon seems to be looking for something just outside of its cave. A pile of burnt and cracked bones spills out of the cave behind the dragon. The dragon looks everywhere except right at the characters. It roars one more time and flies off toward Camelot castle.

If the cave is searched the characters discover a huge pile of skulls with fang marks all over them. In the back of the cave are three sets of highly useful powered armor. The characters will find them easy to use and the androids of Camelot will treat them as just another style of plate mail.

**Power Armor** — These suits of power armor are powered by fusion cores (1 week duration). Alternately, 4 power cells of any type may be inserted into the backup power array (4 hours of operation per cell).

The power armor interfaces with the user's brain using sensors (Complexity 4). If the wearer fails the check, a limb suddenly jerks and breaks a bone, causing 3d6 in damage. Only humanoids of roughly human normal proportions will fit in the armor.

The right arm has a built-in laser pistol. This set of armor is a light version of the battle armor worn by marines assigned to the *Warden*, used for scouting hostile terrain. It contains an air supply to vacuum or underwater operations.

**Power Battle Armor:** DEX 18, STR 18; AC 0; HD 00; HP 100; YPM 20; #ATK 1; laser pistol (WC 6; 5d6/10d6/15d6 on 1st, 2nd, and, 3rd hits on the same target; range 75'); SP life support, built-in radio.

In the old days the dragon was easy to kill and made for a great quest for the tourists. It became impossible to kill as the artificial intelligence of the area went insane. The dragon doesn't do much damage now – generally remaining in its cave, but it does have the potential to kill the characters if they do not retreat, and may cause long-lasting damage to the park.

## CAMELOT'S LOCH

### CAPTAIN MARK 'O THE FOREST'S LAKE VOYAGE

The Loch Ness Dock is shrouded in fog and once the characters approach, Captain Mark comes to meet the characters. The gentle sound of water lapping at a lakeshore can be discerned. As they take a first step into the park here, a dark music fills the area with deep drums and bagpipes. Robotic bears bring Camelot style equipment to the characters of the group at the order of Captain Mark.

**Captain Mark 'o the Forest (Android)** - AC:7, Hit Points:150, Movement in Spaces:12, Radiation Resistance:14, Constitution:14, Mental Resistance:14, Strength:18+, Dexterity:14

**Appearance:** He is seven feet tall and appears massively muscled. He's wearing a white sailor suit with a white captain's hat. He has a soothing voice and somehow everything he says sounds true. His face is lined and sports a curly, black and silver beard.

**Normal Reactions:** The android wants people to remain calm. He casually uses his massive strength to rip apart the many sea monsters that try to get into his boat. During these fights blood splatters everywhere, but the unflappable Captain Mark just keeps explaining in a Scottish brogue about the many colorful and historic features of the lake and coast.

Attacking him is a very bad idea. With the first sign of aggression this android sailor calls down lightning and arcs of lightning crawl over his body. He is then able to hurl two lightning bolts at two different characters at the same time. The lightning does 30 points of damage a strike, at WC 8.

**Mutations and Defects:** None

Captain Mark explains that all equipment and vehicles must be left on the outside of the park when the characters come in to experience Camelot. Hidden emplacements in the forest gloom fire lasers at groups that try to enter without following the Captain's instructions. These emplacements have a range of 300 yards

and do 45 points of laser damage, WC 3. It is possible to run past them and into the park, but not before taking 4 shot attempts from the weapon systems.

If they agree, Captain Mark will let them aboard his sailing ship, and bear them across the lake into the park.

On Captain Mark's vessel, the group gains Camelot equipment and must leave their materials or they can't come into the park.

- 1: Humans get asked their names and are from then on called Lord or Lady this or that according to the names they have given. Their clothes are replaced with wondrous Camelot Clothes. Clerical robes are provided for each character. The female robes are quite stylish while the male robes are a dark black. Each character is given a powerful war hammer that does 25 points per hit and can be thrown up to 50 yards to return to the character.
- 2: Humanoids are given a suit of armor as they are supposed to take part in the challenges of Camelot. They are given a pack horse for that armor. Otherwise they are given colored tabards with their choices of symbols on the tabards. Each fairy is given a long bow and a quiver of 20 arrows. Each of these arrows never misses and inflicts 20 points of damage. Naturally the arrows are broken with use.
- 3: Pets are given a tabard with their owner's name. The owner is given an band and the pet is given a collar and both pet and owner know exactly where the other is in the park at all times.
- 4: Characters without some humanoid leader are shooed away with a pyrotechnic display from one of the wizards or druids in attendance. If that doesn't scare away the creature, laser emplacements blast away until the creatures or robots are dead. Wolfoids are immune to laser blasts and packs of them often get into the park from one of the entrances.
- 5: Cyborg characters are difficult for the androids to deal with. They usually strip them of all of their lose equipment and give them wizard's things and make them junior Merlins. A Merlin is given a wand that shoots a 30-point lightning bolt. After ten shots the wand tries to open itself to the sun for an hour of recharging. Merlin's also have special quests and can talk and order around fantasy creatures if they give that a try. The cyborg can use all of its equipment, and those powers are ignored by the androids of Camelot.

If the characters remain on board, Captain Mark takes them on a tour of the park. While they float by Stonehenge, Camelot, and other places the boat is attacked, time and time again, by the Loch Ness monsters and other tentacled horrors. All the while Captain Mark keeps up his speech about the various interesting places, he is chopping at tentacles and Nessy heads and getting covered in gore and blood. This boat never sinks and he never dies. Every morning he appears again in a neat captain's suit with a happy disposition.

From the boat the characters are encouraged by Captain Mark to go to Camelot or go to Stonehenge. The attacks from the sea monsters are supposed to be absurd and harmless as the android captain has no trouble cutting them to pieces.



## LOCH NESS PATH ALONG THE LAKE

---

This is a lovely fall path around the lake. It seems to be a large animal trail and indeed there are lots of mutated deer and bears that can be seen using the path. However, if the characters take this path, within one hour they will be attacked by a long-necked aquatic dinosaur with a huge head and massive fangs.

**Loch Ness Monster** - AC:5, Hit Points:99, Movement in Spaces:water 14, Radiation Resistance:18, Constitution:18, Mental Resistance:9, Strength:18, Dexterity:18

**Mutations:** None

**Appearance:** It's a creature straight out of the dinosaur vids, as it rises from the water and easily reaches all the way down onto the forest path to attack. It's 90 yards long and 40 yards wide. It has a green hide and there is a great deal of moss along its body.

**Normal Reactions and Attacking:** The creature bites for 3d6 in damage. It has terrible vision and needs a high roll to every successfully strike a character. It can effortlessly bite into an android horse. If it takes more than 50 points in damage it retreats into the lake, never to be seen again.

## LOCH NESS PATH INTO THE WOODS

---

Use the wandering monster chart for an encounter here. If the characters are traveling slowly in this area give them two wandering encounters. The first group they meet are all holding, but not using, heavy laser rifles that the characters can figure out how to use if they try hard enough.

## WITCHES HUT G

---

This is a large and run down looking log cabin along a large forest path. There is smoke coming from the chimney. The building looks to be 70 yards long and many yards deep as it extends into the forest. There are skulls of all types hanging on the outside walls and sitting in piles all around the cabin. Some of the skulls are massive. All of them are bone white and picked clean of flesh. The only door is quite large and clearly much taller than the height of a normal human. There are several windows in the walls of the cabin and these show the glow of firelight inside.

**Swamp Witch** - AC:4, Hit Points:133, Movement in Spaces:14, Radiation Resistance:17, Constitution:17, Mental Resistance:17 Strength:17, Dexterity:17

**Appearance:** She is nine feet tall and dressed in a black silk gown. She has long lustrous blond hair and pretty facial features except for the numerous black moles on her face. She is holding a 15 feet long quarterstaff with large silver caps on both ends.

**Normal Reactions:** She stays in her cabin unless the characters break open the door. Then she fights for her life. She strikes twice a combat round with her staff for 3d6+9 points of damage, at WC 5.

**Mutations and Defects:** HEIGHTENED INTELLIGENCE, HEIGHTENED STRENGTH, HEIGHTENED DEXTERITY

The huge cabin is a single chamber with all the features of home. Under the giant bed is a chest of 20 energy grenades of all types. On shelves by the fireplace is a set of nine nano-tech healing potions doing 12 points of healing per bottle. On the kitchen table is a set of 30 large white mushrooms that are deadly poison to eat.

If the characters try talking to her, they will find her angry and only interested in getting the group to leave her cabin.

## WITCHES TOWER F

---

The tower is 90 yards tall. There is one large window at the top of the spire of the tower. No other entrance is visible. If the characters call up to the tower a lovely young lady (the perilous black witch in disguise) shouts down to them. They talk back and forth and learn that she has been there for ten years. When her mother wants to enter the tower she sends down her long braid of hair and the mother climbs up and into the tower. If the characters try this they are told that only one can try at a time. The thick braid is lowered and the climb is easy.

There is great danger in this effort. The braid is from a mutant plant creature and only looks like hair. As each character climbs up the braid is grows thicker and wider around them. By the time they are up to the window they can't be seen by anyone down on the ground. After entering the window the character is completely surrounded by the plant braid and becomes a prisoner of the witch. She then calls down for the next person to climb up the braid. She uses ventriloquism to simulate the voice of the last person to come up. The fake voice assures the characters that everything is fine.



**Perilous Black Witch** - AC:7, Hit Points:213, Movement in Spaces:15 Radiation Resistance:18, Constitution:18, Mental Resistance:18, Strength:18, Dexterity:18

**Appearance:** The witch stands eight feet tall and is incredibly hairy from her hands and feet to the many yards of hair on her head. This one is a weaver and has woven a hair dress that acts like armor. There are three long braids on her head and these braids act independently like whips doing 2d6 with each successful strike, WC 5. One brain controls the attacks of the braids, while the other brain works the body.

**Normal Reactions and Attacking:** She doesn't like invaders and screeches at them if they break out of the braid trap. If they stay and do battle she begins life leeching them. She is very capable of faking being unconscious and continuing to life leech the characters.

The tower with three levels of chambers is filled with a group of trapped creatures with poison stings. Under the bed are scorpion-like creatures. In woven baskets are several different types of angry poison snakes. In the oven is a huge wasp nest where the wasps fly out to sting the characters if the oven is opened. Feel free to add more poisonous creatures. None of them are at first visible in the tower. They are only released by the searching action of the characters.

**Mutations and Defects:** LIFE LEECH, VENTRIL-  
OQUISM, DUAL BRAIN, RESISTANCE TO ENER-  
GY ATTACKS

**Defect:** CAN'T SEE DOG-LIKE PETS

## LEAVING THE PARK

As the characters are ready to go, they are asked their names. The Camelot androids are happy to return all of their old equipment held in storage, and indicate that the equipment provided for them at the park is their souvenir of their 'Camelot adventure'..

**Android Knights of the Forest** - AC:7, Hit Points:200, Movement in Spaces:12, Radiation Resistance:18 Constitution:18, Mental Resistance:18, Strength:18 Dexterity:18

**Appearance:** These androids are always dressed in silver-colored plate mail and ride huge android war horses. They first attack with lances and then draw chain- swords doing 3d6 + 15 points of damage per successful strike, WC 4.

**Normal Reactions and Attacking:** These androids cull the forest for dangerous beasts. Over the centuries resident creatures have mutated and others have snuck into the park to set up lairs. All of the dangerous creatures are hunted down and killed by the knights of the forest. Often the sounds of battle and the snarling of massive beasts can be heard in the distance. These knights will appear and help the characters fight battles in the park, if necessary.

**Mutations:** None

## A Derelict City on a Colony Ship Hurling Through Space!

On a spaceship 50 miles long with more than a million colonists, Epsilon City was the single largest habitation. It was filled with entertainment centers, apartments, and offices for all the people moving about the ship during the long voyage. The city was designed to be maintained by its own artificial intelligence (A.I.) and a special series of robots that could repair areas of the city when breakdowns happened.

Epsilon City was less than half full when an interstellar radiation cloud destroyed the people of the ship and turned 99% of them into piles of white ash. The city was wiped out. Now, three hundred years later, things are vastly different in the city. The A.I. is insane and has an aggressive personality. The special robots have had to change or be destroyed, and have mutated much like the rest of the life on the ship. Wolfoid packs now inhabit many sections of the city and consider this metropolis their lair. And many more dangers lurk, hidden and waiting to be explored...

The original edition of Metamorphosis Alpha has celebrated its 40th anniversary! In honor of this milestone, creator James M. Ward has authorized Goodman Games to publish Metamorphosis Alpha: Epsilon City. This huge expansion for the starship Warden is the biggest expansion for the original 1976 edition ever published!



GMG4393  
\$60.00