

Standoff at Sandfell Sea Fort

By
Malrex



Eerie lights? Strange noises? Ships are sailing blind into the rough shores of the Bay of Saurvorn. Why is the light out at Lokrom's Beacon? Will the party find clues to a murderer? Or is there something more sinister at stake.

An OSR adventure for Levels 4-7.



Standoff at Sandfell Sea Fort

Author/Maps/Layout: Malrex

Editor: A.P. Klosky

Cover Art: Publisher's Choice Stock Art ©Rick Hershey/Fat Goblin Games

Backcover Artist: Dean Spencer

Interior Artists: Some artwork © 2018 Dean Spencer, used with permission, all rights reserved. Public Domain, Images on pg. 6, 10, 12, 13, 17, and 19 are by Thomas Novosel

www.patreon.com/thomosnovosel), Patrick E. Pullen, Publisher's Choice Stock Art ©Rick Hershey/Fat Goblin Games, Some artwork copyrighted by Robert Hemminger, used with permission, William McAusland, Nathan Atterbery, Maciej Zagorski of The Forge Studios, and Joe Calkins. All artwork is copyrighted by the artists!

Author's Note

I had some fun with this one. I wanted a sea adventure without the usual sahuagin as the focus....and luckily I had some great art to inspire me! I want to thank Nathan Atterbery for providing the art and name of the Ghuhudan. I love his style of artwork. I also found Thomas Novosel's patreon and wow!! Lots of art that takes me out of the box. If you are into art, I recommend you check out what he is up too.

www.patreon.com/thomosnovosel

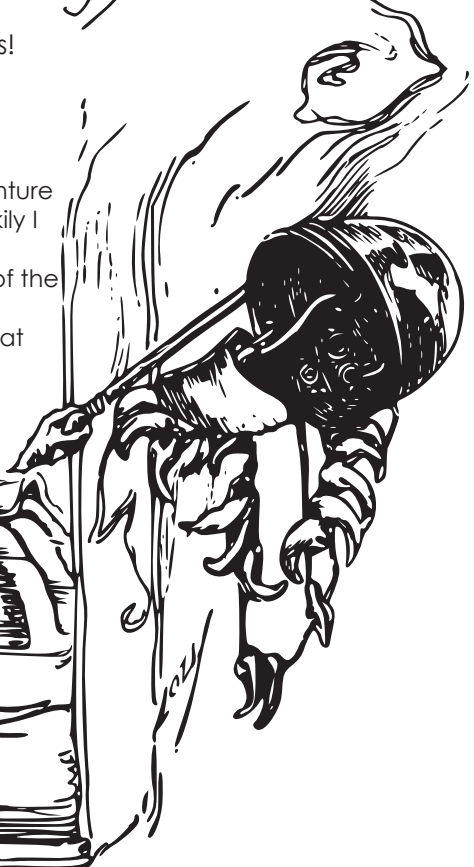
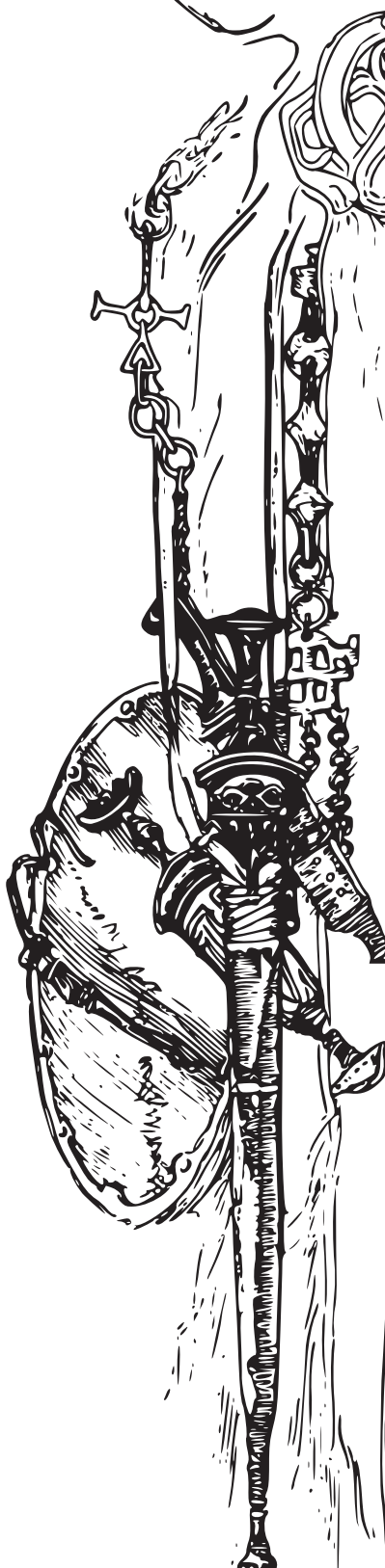

Standoff at Sandfell Sea Fort

Introduction: Lokrom's Beacon has been extinguished for more than a week. Without warning from the beacon, ships have struggled to navigate the rough coast of the Bay of Saurvorn. In fact, one ship, The Jolly Merchant, crashed along the shoals a few nights ago, its captain raving about strange lights and a crew possessed! While a rescue party departed to help survivors and recover lost goods three days ago, Lord Dremens of Mjova wants to hire a party to check on the lighthouse.



Artist: Dean Spencer

Summary: The warden of Lokrom's Beacon was murdered by a tribe of Histrix, who were angered by the light shining upon their new dwelling, the old Sandfell Sea Fort. However, during the assault, they shattered a sea captain's old magic bottle which contained an angry air elemental. However, most of the Histrix managed to escape with their lives.

Meanwhile a tribe of peaceful Ghuhudan has floated into the Sandfell Sea Fort territory on floating kelp beds, latching themselves to a reef. Seeking a new home to rebuild, the Ghuhudan have settled on the idea of inhabiting the sea fort. However, as negotiations have failed and their reef-perch grows more precarious, the Ghuhudan grow desperate for resources. The Histrix raided their village, taking several prisoners, and the Ghuhudan recently retaliated by sending in a war party to free their family members, but the outcome is unknown.

Nearby, the ship known as the Jolly Merchant is actually a pirate ship called The Red Tempest, now run aground on a reef. Earlier, these pirates had great luck salvaging from sunken ships surrounding the unlit lighthouse. However, the Red Tempest now has a huge hole near the keel and continually gets bombarded by waves. The ship lies next to the cavern home of a rare Crown of Thorns starfish which has begun using its *Domination* ability to create slaves from the hapless pirates. A disheveled band of Red Tempest pirates have escaped to dry land, currently debating on a course of action (**Area #4**).

GM's Notes: Histrix and Ghuhudan are in the New Monster section in back of the adventure. Random encounters are a 1 or 2 on a d10 every 6 turns. See the Bay Encounters Table and the Seashore/Land Encounters Table.

Adventure Hooks:

1. Lord Dremens of Mjova hires the party to investigate the lighthouse, offering them 150 gp each. He also supplies a small drakkar and 5 sailors (level 0) for the journey.

Continued

Roll	Bay Encounters
1	Storm. Choppy waters. 35% veer off course if on water, lose 1d6 hours of time.
2	(6) Histrix Patrol: AC 4, Move 9 (land) 12 (swimming), HD 5, hp 33 ea, THACO 15, Attack 1 (by weapon), MR 25%, Size M, Morale 15, XP 975 ea. Special: Project Force, Inertial Barrier abilities. Each Histrix have tridents or spears, daggers, 8 sp, and 9 gp. These Histrix attempt to loudly jab a hole in a small drakkar or sailing vessel.
3	(1d2+1) Giant Crab: AC -2, Move 12, HD 6, hp 38 ea, THACO 15, Attack: 2 claws (1d6 +2 damage), Size L, Morale 15, XP 650 ea. Fighting over a drowned, dead sailor corpse for lunch.
4	(2d6) Shark: AC 6, Move 24 (swimming), HD 4, hp 26 ea, THACO 17, Attack 1 (bite 2d4), Size L, Morale 8, XP 175 ea. These sharks swim near the boat, attacking anything that falls overboard.
5	(2d4) Seals: AC 7, Move 3, 18 (swimming), HD 1, hp 8 ea, THACO 20, Attack 1 (bite 1d4), Size M, Morale 6, XP 35 ea. These playful seals swim and bark around the boat for awhile before swimming off.
6	Floating wreckage. A keg of wine (75 gp), debris and spliced rope.
7	(2d8) Tritons: AC 5, Move 15 (swimming), HD 3, hp 18 ea, THACO 17, Attack 1 (by weapon), MR 90%, Size M, Morale 13, XP 650. Equipped with tridents, spears, and daggers. These tritons watch the ship from a distance.
8	(1d4) Scrag: AC 2, Move 3, 12 (swimming), HD 6+1, hp 38 ea, THACO 13, Attack 3 (2 claws 1d4, bite 1d8+8, Size L, Morale 15, XP 1,400. These scrag await an opportune time to attack.

Roll	Seashore/Land Encounters
1	(1d2+1) Giant Crab: AC -2, Move 12, HD 6, hp 38 ea, THACO 15, Attack: 2 claws (1d6 +2 damage), Size L, Morale 15, XP 650 ea. Fighting over a drowned, dead sailor corpse for lunch.
2	Storm, freezing rain and wind. 25% to get hypothermia unless cover is sought.
3	(6 + 1d6) Bandits: AC 5, Move 12, Lvl 4 Warrior, hp 30 ea average, THACO 17, Attack 1 (by weapon), Size M, Morale 9, XP 175. Rag tag band equipped with rusted chainmail, longswords, battle axes, and longbows. Each have 1d12 sp, 1d6 gp. They are scattered about a campfire, some sleeping. Attempt to negotiate a 'safety fee' of 25 gp each for safe passage.
4	(1d3) Griffons: AC 3, Move 12, fly 30 (MC 3), HD 7, hp 44 ea, THACO 13, Attack 3 (2 claws 1d4, bite 2d8), Size L, Morale 11-12, XP 650 ea. These hungry griffons are searching for any type of food. One is completely soaked from attempting to dive bomb a seal.
5	(1d12) Wild Boar: AC 7, Move 12, HD 3, hp 17 ea, THACO 17, Attack 1 (3d4 damage), Size M, Morale 10, XP 120 ea. These boar are in a foul mood, finding meager food. They attack to protect their young (3 piglets).
6	(2d4) Bugbears: AC 5, Move 9, HD 3+1, hp 20 ea, THACO 17, Attack 1 (slam 2d4 or by weapon, Size L, Morale 11-13, XP 120 ea. They got a total of 52 gp, and a ruby 100 gp that they are taking to another tribe to trade for a female for their chief. If they can offer prisoners instead of the ruby, all the better.
7	(2d6) Giant Sea Iguanas: AC 5, Move 12, HD 3+1, hp 16 ea, THACO 17 Attack 1 (bite 1d8+1), Size L, Morale 10, XP 175. Special: On a natural 20, bite does double damage. These iguanas feed along the shallow reefs and seashore. They attack giant crabs on sight. They defend themselves if attacked.
8	(1) Donkey: AC 7, Move 12, HD 3, hp 19, THACO 17, Attack 3 (2 hooves 1d3, bite 1d6), Size M, Morale 5-7, XP 65. This donkey escaped the rescue party. It has a week of iron rations, 2 waterskins, a healer's satchel, a silver flask of rum (25 gp), 50' rope, and a shovel. It keeps running from rescuers...a pain in the ass.

2. Vorkas, the general store owner, offers the party 50 gp each to obtain any supplies from the run around Jolly Merchant (Red Tempest).

3. Meeples, the half-crazed survivor of the Red Tempest, is mostly belligerent, but speaks of strange lights and a fearsome beast in a cave that took control of the crews' minds!

4. The Jax family worries about their missing patriarch. They can only offer shelter and meals for the party if they investigate the lighthouse, but they offer the use of their small rowboat for free.

5. Larangos, a powerful mage of the far off Darkcrest Tower, has offered the party 500 gp to obtain the brain of a Histrich for research. He has heard a small tribe may be located at the Sandfell Sea Fort.

6. Pretty Maura of Mjova, devastated by her son's decision to sail off with pirates offers an emerald (250 gp) for his capture and return. She believes that pirates regularly patrol the bay and have shanghaied her son.



Artist: Dean Spencer

The Bay of Saurvorn

1. **Mjova:** Once a bustling border trade town, Mjova has been reduced to a ramshackle fishing village as larger cities drew greater population and wealth. Several buildings are boarded up and run-down, while the remaining folk have relied on fishery as a livelihood. Lokom's Beacon is the only important thing sea-farers care about when nearing Mjova, and ships usually only port for emergencies or a rare supply run. Desperation for resources has led to a wary truce with a number of pirates, making Mjova a safe harbor for the lawless men if they stay discreet.

Important Establishments:

- **The Lobster's Whiskers:** Mjova's only Tavern, is run by Gilroy, a hefty, balding fellow who is handy with a club. He likes a quiet crowd with no disruptions. Usually 1d8 patrons at all times, +10 at night (most are pirates). Kilroy and his twin brother Serak are the town drunks, frequently found arguing or fist fighting in or near the tavern. Check rumor table, roll 1d4 times.

- **Dawn's Pearl:** Mjova's general store, owned by the skin-flint Vorkas. A weasel looking man with greasy hair, Vorkas is known for his steep prices and his disdainful gaze.

Roll	Rumor
1	I thought the lighthouse was working again, but the glow of light was past the lighthouse. It was a clear night, and the lights shifted from a light purple, to eerie green!
2	Calos swears he saw the biggest crab he has ever seen along the coast to the east. He yapped at me sayin he would use the shell for a hut or some such nonsense. Hmm, funny thing, I haven't seen him around lately.
3	I think the lighthouse is haunted. I took a rowboat out there, but the water got too rough. But I heard the weirdest moaning sound I've ever heard!
4	Don't let em fool ya. That Jolly Merchant ship...yeah, it ain't no merchant ship. It's a band of pirates!
5	I saw a naked woman swimming in the bay just the other day! Not sure how she wasn't freezing. She looked like she was crying. Was the strangest thing. She bolted off swimming and I lost track of her.
6	Lord Dremens ordered the lighthouse to be shut off. He thinks Port Hollowane will send us money to turn it back on!
7	I heard Captain Grome pays off pirates so that they don't cause a ruckus in town.
8	The Sandfell Seafort was abandoned awhile back. The tides kept coming in and flooding it. Darn fools built it too close to the sea!

- Mjova Fort:** Lord Dremens, the nominal ruler of Mjova, is a fair, grim man who does his best to keep his people safe. While his garrison is small—only 10 soldiers (each level 1 warriors), Dremens is proud of his station and his town. Proud Dremen is often accompanied by his captain, Grome, a grizzled veteran who enjoys telling old war stories, especially after a pint or two of ale in The Lobster's Whiskers.
- The Deep's Glow:** A homely inn run by the middle-aged Evelyn, rates at The Deep's Glow run 1.5x the regular price. Evelyn likes to gossip, but has a heart of gold, often letting homeless individuals stay for free, if needed. Most often, though, her inn is empty. Check rumor table, roll 2 times.
- Other Buildings:** Mjova has only the barest of other businesses. The rest of the village features candle store, leather-worker, fishing supply shop, boat builder, blacksmith, and bait shop. A fair number of stray cats wander the muddy streets.

2. Lokrom's Beacon: Slender, dark, and storm-stained, Lokrom's Beacon squats on a barnacle covered rock outcropping, defiant towards the crash of violent waves that surround it. Ocean mist drenches a rickety dock, which extends into the chaotic turmoil of the sea. A steep staircase hugs the rocky cliff as it winds its way towards the lighthouse's base. See **Appendix A: Lokrom's Beacon.**



3. Bloody Sands: Here, sand forms a long beach with rolling dunes covered in scrubby beach grass. Shells, pebbles, wooden debris, and bits of garbage litter the beach and small crabs scatter and dive into their holes.

- Three giant crabs make their home amongst the dunes and are eager for an opportunity for fresh food. They are near the wagon.
- A wagon, a half-eaten horse, and bits and pieces of decapitated men from the rescue party are scattered about the beach. Amidst the bodies and the wagon, supplies include: iron rations, blankets, various mundane weapons, waterskins, 150' of rope, a bundle of bandages, and 21 sp.
- Walking near the shore gives a 25% of finding a watertight scroll tube containing a scroll of wizard spells: Level 6: *Invisible Stalker*, Level 5: *Feeblemind*, and Level 3: *Water Breathing*.

Monster: (3) Giant Crab: AC -2, Move 12, HD 6, hp 44, 40, 36, THACO 15, Attack: 2 claws (1d6 +2 damage), Size L, Morale 15, XP 650 ea.

4. Pirates: A rowdy-looking and disheveled band of men and women whoop and yell at the sight of the PCs, waving their arms above their heads. The band immediately starts running towards the PCs.

- Their excitement may be taken as an attack, but they immediately dive for cover and/or try to defuse the situation.
- This misfit band of people is at their wits' end. They are part of the pirate crew of The Red Tempest. Surprisingly, they like their captain due to their success and want her back. She has been dominated by the Crown of Thorns Starfish (see **Area #5**).
- The pirates attempt to talk, trick, manipulate and/or intimidate to get the party to rescue their fellow 'merchants', and they are willing to lead the way to the location. One burly lug named 'Silver Tooth' does most of the talking (*dim-witted, rough, yet cautious*).

Monster: (7) Pirates: AC 8, Move 12, Level 3 Warriors, hp, 28 (Lug), 24 x 5, 22, THACO 18, Attack: by weapon, Size M, Morale 9-11, XP 120 ea. Equipped with cutlasses, daggers, and belaying pins.



Artist: Thomas Novosel

5. Crown of Thorns: A rough and rocky section of beach with scattered rock outcroppings that tirelessly get pounded by waves. A cog style ship leans on its side continually getting bashed by waves that have the ship pinned against the jagged rocks. A sizable rock outcrop has collected a bit of sand about it, with a cave that leads inside. See **Appendix B: Crown of Thorns**.

6. Land...Shark?: Sandy soil, scrub brush, and a few windswept trees seem to stretch for miles. The PCs can hear a slight rumbling noise which seems to be getting closer. A fin breaks the surface nearby...

- The party has 1 free round to react before the bullette is upon them.

Monster: (1) Bullette: AC -2/4/6, Move 12, 3 burrowing, HD 9, hp 58, THACO 11, Attack 3 (3d6, 3d6, 4d12), Size L, Morale 13, XP 2,000.

7. Ghuhudan Village: A huge kelp entwined 'island' floats, lashed to a few protruding rocks. Kelp with wooden pole reinforcements serves as 7 small huts. Wooden poles with strange glass balls stand scattered across the kelp island. Bulky creatures resembling humanoid elephant seals wander about, many carrying fishing poles.

- The Ghuhudan gather to greet the party. They are very cautious and consist of 5 families, mainly females, children and the elderly. Only a handful of young, male Ghuhudan protect the village.
- The glass balls emit a light purple light at night, but cast an eerie green light if the village is under attack. These lights can be seen from the lighthouse by night.
- The Ghuhudan leader is old with thickly calloused skin. If treated with respect, he tells the party:

1. They floated here and were attacked by the Histrix. Histrix are a type of sea-horse people living in the sea fort, who took many Ghuhudan family members as prisoners during a recent raid.

2. Angered, they sent in a war party to recover their family members. It has been two days since the war party was sent and they have not received any word.

3. They wish to lay claim to the fort and live there peacefully, as the cliffs provide bird nests and eggs are a delicacy.

4. He believes the Histrix attacked the "Great Light" (Lokom's Beacon) about a week ago.

- The Ghuhudan offer a bag of pearls (500 gp) for the party's help to recover their family members from the Histrix. One Ghuhudan, Mirounga, accompanies the party if desired. An older female presents a robe made of lacquered shells to a random spellcaster in the party (provides AC 8, but loud), as well as a **Potion of Water Breathing** for each party member.

Monster: (8) Ghuhudan: AC 6, Move 9, 18 (swimming), HD 4, hp 27 average, THACO 17, Attack 1 (by weapon), Size L, Morale 11, XP 270 ea. Equipped with gaff hooks, daggers, and spears.

(4) Ghuhudan Guards: AC 6, Move 9, 18 (swimming), HD 6, hp 42 (leader), 37, 35, 34, THACO 15, Attack 1 (by weapon), Size L, Morale 13, XP 420 ea. Equipped with gaff hooks, daggers and spears.

Mirounga: AC 6, Move 9, 18 (swimming), HD 4, hp 29 THACO 17, Attack 1 (by weapon), Size L, Morale 13, XP 270. Equipped with a gaff hook, dagger and a spear. *Angry, stubborn, fearless, and loyal. He doesn't hold the line....he IS the line.*

8. A Plea: Above the lapping of waves, sobbing and whimpering can be heard amongst the exposed, seaweed covered reefs.

- An injured mermaid rests near the reef. Desperate, she attempts to talk to the party. If Mirounga is with the party, she attempts to fly while Mirounga licks his chops.
- She claims she is scared of the human town, and the Ghuhudan tried to eat her, but she seeks assistance. Her lover, Narius, was captured by the Histrix three days ago and she begs the party to enter the fort to free him. She provides a shell necklace as proof for her lover that the party are friends if they decide to help.

Monster: Velmous, the Mermaid: AC 7, Move 1, 18 (swimming), HD 1+1, hp (4) 8, THACO 19, Attack 1 (dagger 1d4), Size M, Morale 10, XP 35.

9. Sandfell Sea Fort: This old sea fort is tucked inside an eroding cliff face. A sandy stairwell leads up to an exposed platform with three solid doors embedded in the cliff. A short sandy swath of beach is nestled below the platform. Please refer to **Appendix C: SandFell Sea Fort** and the Sandfell Sea Fort map.

Appendix A: Lokom's Beacon

GM's Note: There are no wandering encounters while inside the lighthouse. Perceptive characters notice drag marks near the lighthouse (Histrix tracks). See Lokom's Beacon map.

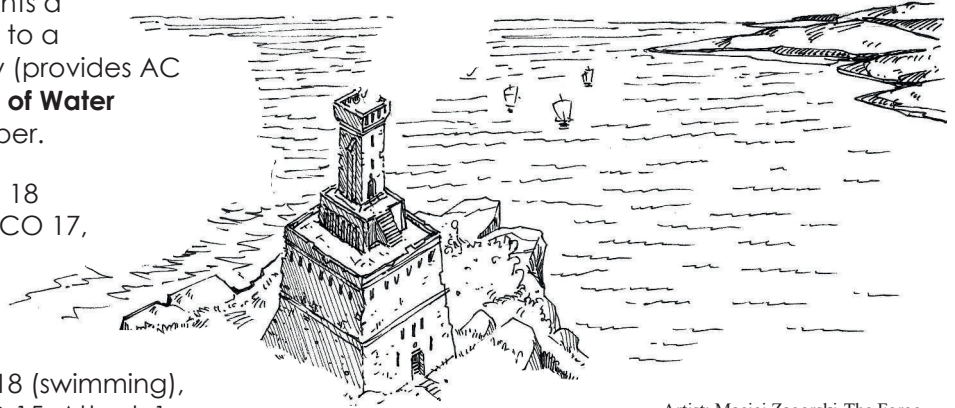

Artist: Maciej Zagorski-The Forge

1. Larder: Drag marks enter/leave through the door here. The rusty metal door opens into a spacious room filled with random crates and, barrels filled with miscellaneous supplies such as rope, lanterns and lantern oil. A messy eating area with spilt, now-moldy porridge is in the northeast corner. An impressive carving of a huge sea snake swirls its way up to the next floor in the form of a spiral staircase.

- Besides the supplies, there is a small keg of brandy that could fetch 150 gp.

2. Bunk Room: This spartan bunkhouse contains a simple bed with a wooden wardrobe.

- From this room, the party can hear moaning and whistling from wind upstairs.
- The wardrobe contains a waterproof sealskin poncho, a bunch of musty clothes and two pairs of boots. A silver dagger (200 sp) is thrust inside one of the boots.
- The diary of Borgrek Jax lies under a pillow. Besides day-to-day ramblings, several passages near the end that discuss strange lights by the old Sandfell Fort. The colors range from a light purple to an eerie green. Borgrek shifted the beacon upon the area, but the lights stopped glowing and he wrote that there were 'booming noises erupting from the area' (the Ghuhudan). The Jax family will pay 25 gp for the diary's return.

3. Rec Room: A whirlwind of fluttering papers, books, maps, and ash dominates the center of this cramped room, obstructing both vision and hearing. Two glowing yellow orbs flare in the middle of the mini-tornado and the whistling sound becomes a low moan.

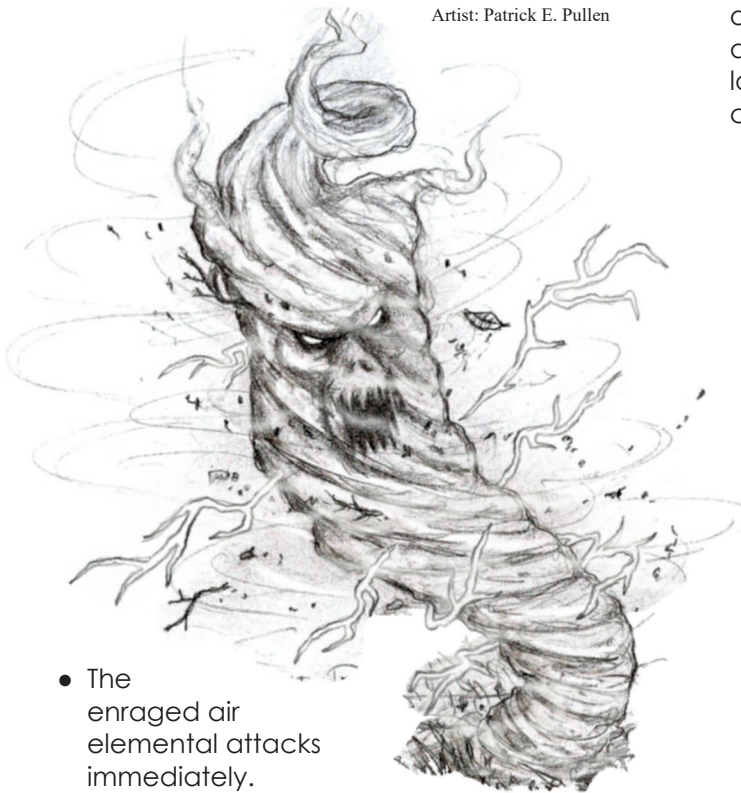

Artist: Patrick E. Pullen

- The enraged air elemental attacks immediately.
- Most of the papers consist of sea charts, star constellations and random sea maps.
- The books cover subjects such as boats, fishing, underwater critters, and seafood cooking recipes. There are a few famous books- 'Captain Reefclaw's Guide to Seamanship' (75 gp), and "Lydia Snoose's Guide to Rope Usefulness" (300 gp). Those spending an uninterrupted week reading Lydia Snoose's manual and practicing its techniques can gain the Rope Use non-combat proficiency as a bonus.
- **Secret Compartment:** The fireplace contains a shifting metal plate half-covered by ash. Under the plate, a soot-stained, sealskin pouch contains 45 cp, 23 sp, 117 gp, and 2 pearls (125 gp each).
- Once the air elemental is slain, the PCs might find a broken bottle glass scattered in with the paperwork. A labeled piece of glass states "Ol' Cap Shiftywalk's Sailing Advantage." The Histrix knocked over the bottle releasing the elemental.

Monster: (1) Air Elemental: AC 2, Move 36-fly (MC 1), HD 8, hp 54, THACO 12, Attack: Buffet 2d10 damage), Size L, Morale 15, XP 4,000. Special: whirlwind, +2 or better weapons to hit.

4. Murder Scene: Tiny crabs dart away from a bearded man's corpse, which lies crumpled in a pool of congealed blood near the stairwell. A dagger with a fish shaped handle lies next to the nearby wall. A low table sits nearby, covered with papers.. The stairs continue upward to a trap door.

- The corpse is that of Borgrek Jax. He died of piercing wounds (spears, tridents) and looks to have been dead for more than a week.
- The dagger has remnants of red, scaly skin and dark stains of blood (Histrix skin). The blade is incredibly sharp and well crafted (provides a +1 to damage only).
- The papers on the desk contain ship names, including a list of known pirate ship names (50 gp reward if taken to nearby Port Hollowvane). There is also a book of doodles.



Artist: William McAusland

5. The Beacon: A trapdoor opens up from the top of the staircase. Pillars hold up a ceiling as the room is open to the elements. The room contains angled mirrors from the floor and the ceiling which face a closed 3' diameter metal sphere in the center of the room. Handles protrude from the sphere for easy opening. The crashing waves of the tumultuous sea below send misty vapors throughout the chamber.

- Lifting the sphere shows an impressive rune-lined glass sphere containing a living globe of light that immediately brightens when exposed to outside. The trapped will-o-wisp flees if the glass sphere is broken.

Monster: (1) Will-o-the-Wisp: AC -8, Move fly 18 (MC 1), HD 9, hp 63, THACO 11, Attack: shock 2d8, Size S, Morale 17, XP 3,000. Special: magic immunity.

Appendix B: Crown of Thorns

GM's Note: Refer to the Crown of Thorns Starfish Lair map. At the sandy beach and ship, the party runs into patrolling pirates on a 1 or 2 on a d10, rolled every 3 turns. Pirate patrols consist of 3 to 5 pirates. There are a total of 20 dominated pirates in the area, one of which is Maura's son, Elgrik. The pirates are dominated by the Crown of Thorn's starfish, which used its special ability *Domination* (see New Monster).

Monster: Pirate: AC 9, Move 12, Level 3 Warriors, hp 25 average, THACO 18, Attack 1 (by weapon), Size M, Morale 9-11, XP 120 ea. Equipped with cutlasses, daggers, and belaying pins.

1. The Red Tempest: A gaping hole of twisted wood lies open near the keel. Water weighs down the cog and it rests on top of the shallow rocks but continually rocks under the unrelenting waves. A painted, wood-carved prow resembles a mermaid with a tangle of red hair surrounding a face set in a sneer. A sign hangs limply from the ship's side, that says 'The Jolly Merchant', although clearly visible under it, says 'The Red Tempest'.

- The ship is half submerged, with the hold carrying floating garbage, supplies, four drowned pirates, and several curious fish. Submerged hammocks make it easy to get tangled while moving about the area.
- The captain's quarters has been mostly rummaged and looted for the Crown of Thorns starfish by the pirates. However, a golden candlestick (50 gp) and a necklace of pearls (250 gp) can be found if searched.
- Typical sailing items can still be found on deck (ropes, pails, sails, etc.).

2. Guards: A narrow cave opening leads into the tall rock outcropping. Barnacles and patches of seaweed cling to all the rocks and tide pools are abundant, separated by slivers of sand peninsulas.

- Three dominated pirates are guarding the cave entrance and attack intruders on sight.

Monster: (3) Pirates: AC 9, Move 12, Level 3 Warriors, hp 25 average, THACO 18, Attack 1 (by weapon), Size M, Morale 9-11, XP 120 ea. Equipped with cutlasses, daggers, and belaying pins.



Artist: Rick Hershey

3. Loot Grotto: A cave opening leads out to the sea. A wealth of sea life inhabits the rocky bottom of the grotto. Starfish, anemones, sea urchins, multi-sized fish and crabs amble along the bottom and sides. Various coins are scattered and submerged in the grotto. Four men dump crates and chests of coins into the water.

- There is a total of 1,500 cp, 2,000 sp, 300 gp, and 222 pp littering the bottom of the grotto. Recovering these coins takes a significant amount of time.
- Any fighting in this chamber brings 8 more pirates in 1d3+1 rounds.

Monster: (4) Pirates: AC 9, Move 12, Level 3 Warriors, hp 27 average, THACO 18, Attack 1 (by weapon), Size M, Morale 9-11, XP 120 ea. Equipped with cutlasses, daggers, and belaying pins.

4. Crown of Thorns Starfish Lair: Sand covers the floor of the cave. A huge, multi-armed purple and dark blue starfish grips a stone outcrop along the southern part of the chamber. Thorn-like spines cover its upper bulk and it sprawls over a 10' radius area with 20 arms. Kegs and crates of goods are scattered through the chamber and a few pirates mill about, moving things from one area to other, as if decorating.

- The starfish immediately attempts to dominate someone chosen at random if it is not at its maximum 20 people. It further orders the pirates to defend it from attack.

- See pirate loot table below for the contents of the crates.

Roll	Loot
1	Crate full of netting
2	Crate full of rigging tackle
3	Crate has 3 bolts of silk (50 gp ea).
4	Small wooden box full of multi-colored dyes (300 gp).
5	5 casks of rice
6	12 tanned skins in a huge chest worth 25 gp ea.
7	Crate full of coils of 50' silk rope
8	Box full of glass marbles (worthless)
9	Chest full of herbs and medical supplies. There are 2 Potions of Healing .
10	Crate with straw and water damaged paintings.
11	Crate full of sacks of sugar (34 lbs).
12	Box full of lantern oil (15 bottles).

- Upon the rocks before the starfish are stacks of 9 emeralds (45 gp ea), 5 piece of jade (25 gp ea), and 3 amethysts (50 gp ea) intermixed with colorful shells and a school of colorful fish.
- Eating the entire brain of this particular starfish increases Charisma by 1 point permanently.
- If the starfish is slain, the pirates become free of their mental domination and fight to keep their loot (including the coins in **Area #3**) if there is unsuccessful negotiation. Any pirates from **Area #4 (Bay of Saurvorn)** that traveled with the party sides with their old pirate crew. However, if the party decides not to take the pirate's loot and moves on, Captain Swales stops the party and offers a blue feather from her hat, claiming she will give them free passage to wherever they desire if it's presented to her at a later date.

Monster: Remaining Pirates: AC 9, Move 12, Level 3 Warriors, hp 25 average, THACO 18, Attack 1 (by weapon), Size M, Morale 9-11, XP 120 ea. Equipped with short swords, cutlass, daggers, and belying pins.

Captain Evalyne 'The Fierce' Swales: AC 6, Move 12, Level 5 Warrior, hp 44, THACO 16, Attack 3/2 (cutlass 1d8 +1 to hit, +3 damage), Size M, Morale 15, XP 270. Equipped with sapphire **Earrings of Protection +2**. *Long red hair, comely, blue feathered hat, demanding, strict, but congratulates often on work well done.*

Crown of Thorns Starfish: AC 4 (body) 6 (arms), Move 3, HD 10, hp 73, THACO 11, Attack N/A, Size L, Morale 16, XP 2,000. Special: Anytime the body is hit in melee, thorns deliver 1d4 damage to the attacker. See New Monster.

Appendix C: Sandfell Sea Fort

GM's Notes: The role of the tide in this adventure is up to the GM. Potentially, the platform (**Room #1**) can be relatively dry, though during high tide the sea may be 2-3' deep on the platform, which means **Room #2** is filled with water. All doors in the dry section are half-rotted, faded, and some even have dead barnacles on them. All 'doors' in the wetted portions are composed of kelp curtains. There is a 25% that the party is spotted entering the fort by those stationed at **Area #12** causing the Histrix to be on alert, difficult to surprise, and camouflaged to ambush the party.

Wandering Encounters: For every 6 turns, a 1 or 2 on a d10 signifies a wandering encounter.

Roll	Encounter
1	(2) Ghuhudan: AC 6, Move 9, 18 (swimming), HD 6, hp 11 (44), 15 (38), THACO 15, Attack 1 (by weapon), Size L, Morale 13, XP 420 ea. These injured Ghuhudan move away from 3 slain Histrix.
2	(4) Histrix: AC 4, Move 9 (land) 12 (swimming), HD 5, hp 37, 35, 34x2, THACO 15, Attack 1 (by weapon), MR 25%, Size M, Morale 15, XP 975 ea. Special: <i>Project Force, Inertial Barrier</i> abilities. Each Histrix has 1d12 sp, and 1d20 gp. These blood-thirsty Histrix seek revenge on Ghuhudan within their halls. They immediately attack.
3	A loud splashing noise echoes through the caverns and tunnels, then fades away.
4	(1d3) Scraggs: AC 2, Move 3, 12 (swimming), HD 6+1, hp 38 ea, THACO 13, Attack 3 (2 claws 1d4, bite 1d8+8, Size L, Morale 15, XP 1,400. These scraggs drag half a Histrix behind them creating a disgusting trail.
5	(2) Histrix: AC 4, Move 9 (land) 12 (swimming), HD 5, hp 32 each, THACO 15, Attack 1 (by weapon), MR 25%, Size M, Morale 15, XP 975 ea. Special: <i>Project Force, Inertial Barrier</i> abilities. Each Histrix has 1d12 sp, and 1d20 gp. These 2 are furious with each other over an escaped captive (Old Karl) and very distracted. They go to blows with each other in 1d6 rounds.
6	Old Karl (AC 10, hp 4), a fisherman from Mjova. Ambushed and captured, he just escaped his 2 arguing Histrix captors over who got to eat him. Old Karl keeps mumbling that he will never eat clam chowder again. If taken back to Mjova, he offers 50 gp (all he has) and a treasure map to the party.

1. The Platform: Sandy, barnacled stairs lead to a broad platform 10' off the ground with three solid doors. Bits of driftwood, seaweed and other debris are scattered about the platform.

- The northern and southern doors are easy to open. The central door is rusty and requires a successful Open Doors to open.

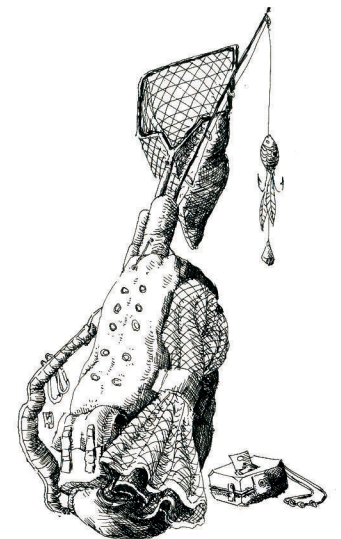

Artist: Thomas Novosek

2. Tide Trap: A series of steep stairs lead to a spacious chamber with sand swept floors and bits of moist seaweed. A rusty steel box sits atop a stone pedestal in the northern alcove.

- **Trap:** Pressure plates near the stone pedestal activate if the box is tampered with, closing two portcullises: one at the room's entrance and one in the hallway between the two stairs. The two portcullises need a successful Bend Bars/Lift Gates to open (or magic). Otherwise, the rising of the tide floods the room and eventually (1 hour to fill room) drowns anyone within it.
- The steel box contains a ship in a bottle and a wand with the inscription: '*Happy Sailing*'. It is a **Wand of Wind Wall** (7 charges).

3. King's Grotto: A short set of slippery stairs lead to a wondrous sea cave grotto. Cracks in the cliff wall to the northwest provide natural light to illuminate the chamber. Coral and rocks fill the bottom of the room, with water flooding the entire room. Colorful sea life occupy nooks and crannies of the coral, and rocks and fish flit through miniature rock arches, caves, and patches of kelp. A lazy current seems to be coming from the western side of the room.

- Water is between 10' to 30' deep in this chamber, with the deeper portion in the southern portion of the room.
- Following the current reveals a hidden entrance by kelp, which leads out to sea.
- Anyone attempting to climb the stairs to **Room #4** is attacked by a hungry Sand King Crawler (see New Monster).
- Fighting near the stairs to **Room #4** has a 25% chance of attracting the resting Ghuhudan that fearlessly join the party against the creature in 1d4 rounds.

Monster: Sand King Crawler: AC 2, Move 6, 18 (swimming), HD 8, hp 60, THACO 13, Attack 3 (2 claws 2d8, bite 3d8), Size H, Morale 14, XP 2,000. Special: Swallows prey whole on a natural 18 or higher.

Treasure: Inside the creature is a morganite embedded bracelet (300 gp), a platinum ring (50 pp), a half decomposed Histrix, and a statuette shaped as a beautiful siren with an inscription of **Shriller** on the bottom.

Shriller

Shriller is a stone statuette shaped as a beautiful siren lying on her back against a reef. Once per day, **Shriller** can be 'armed' and for all intents and purposes, acts as an *Alarm* spell for 8 hours, emitting a dreadful scream when enemies approach.

4. The Resistance: This room smells of sea stench and dead animals. Several corpses of sea horse creatures lay flayed open and scattered about the room. A hoarse and raspy breathing, rag tag group of 'walking elephant seals' sit against the wall, bloody, and exhausted.

- 3 uninjured and 4 injured Ghuhudan have barricaded themselves in this room in this room after their recent forays against the Histrix. They look happy to see Mirounga if he is with the party.
- They know **Rooms #4-6** and have been fighting to enter **Room #8**. They are not aware of **Room #7**.
- They plan to take their injured back to their village. If treated unfairly by the party, Mirounga leaves to join his family. If healed, they offer to help the party.

Monster: (7) Ghuhudan: AC 6, Move 9, 18 (swimming), HD 6, hp 48, 44, 42, 15 (38), 10 (43), 5 (33), THACO 15, Attack 1 (by weapon), Size L, Morale 13, XP 420 ea. Equipped with gaff hooks, daggers and spears. One carries a trophy—a headband made with shells and rubies (300 gp).

5. Massacre: The room is full of congealed blood, guts, and the stench of death mixed with old, dry seaweed. Five Ghuhudan, pierced in several areas by weapons, lie scattered about the floor from their death throes. Dark ichor stains the path leading through the door to the east, as if something(s) were dragged through the doorway. The walls have painted murals of sea life, sailing ships, and islands. A table rests against the south wall with old, faded sea charts.

- One mural shows the sea fort when first constructed long ago, immaculate and set against a solid cliff, with a narrow harbor for 1-2 ships.

6. Storage: Broken bits of wood, glass, debris and rubbish litter the floor. A strange lantern filled with water and two orangish glowing jellyfish teeters on an upturned keg. The lantern emits unusual dancing shadows against the walls.



Artist: Thomos Novosel

- The lantern is common among Histrix and emits light 10' radius underwater. The jellyfish are harmless.
- Nothing else of value.

7. Secret Relaxation Room: Dry and dusty, this room has been unused for quite some time. A plush, comfortable chair squats in the center of the room, facing the south wall next to a huge, 6' tall conch shell on a wooden stand. A mirror covers the entire south wall.

- Once someone sits in the chair, the entire mirror erupts into a scene of sea life, acting like a window looking into the sea or aquarium. The shell begins to slowly build up tempo of a dull roar of the ocean.
- Sitting in the chair for a turn, causes the individual to fall asleep in total relaxation. 4 hours in the chair acts like a full night's sleep and the user may regain spells and heal wounds as if they had rested for the full night.

8. Three Pillars: Stairs leading up to this room have three dead Ghuhudans splattered and disemboweled across the floor. A message is scrawled on the wall with the Ghuhudan's blood 'Die Sea Slugs'. The door requires a successful Open Doors check.

Loose furniture topples over as the door squeals open. The room has 3 ornate pillars carved to look like jellyfish at the ceiling with sprawling tentacles reaching the floor. A knocked over copper brazier (50 gp, 35 lbs) sits in the middle of the pillars, coal scattered about the floor.

- 5 Histrix are camouflaged here, lying in wait to ambush the party.

Monster: (5) Histrix: AC 4, Move 9 (land) 12 (swimming), HD 5, hp 37, 34, 33x2, 29, THACO 15, Attack 1 (by weapon), MR 25%, Size M, Morale 15, XP 975 ea. Special: *Project Force*, *Inertial Barrier* abilities. Each Histrix has 15 sp, and 12 gp.

9. Secret Den: Stairs lead up to a dry, dusty chamber with a stout, ale-stained table in the middle surrounded 6 plush chairs. Half the table is covered in maps and scrolls. On the south wall is a stuffed sea-snake with enormous, sharp teeth with spindly fins. Two axes are mounted on the eastern wall with a round shield in the middle. A tattered dark blue banner with an upside down golden trident and five silver, squiggly lines representing waves hangs on the west wall. A moth-eaten blue rug covers most of the stone floor.

- The maps show most of the coast, the shallows, and major towns.
- One map depicts a treasure map. It leads through a swampy canyon, near a village called Kharazan, has notes on some sort of Bone Cult, and provides a description of a magical helmet known as **Vornskaar**.
- The banner holds an ancient magic and is known as **Oddgeir's Banner**. A bard or sage may know the history of the heraldry.
- The axes and shield are mundane, but still functional.

Oddgeir's Banner

Oddgeir refers to an ancient people that lived along the coast on the Harokian Islands. Excellent seamen, they dominated their territory. Their symbol was an upside down golden trident and five silver, squiggly lines representing waves on a dark blue background. While the Oddgeir people and culture were completely wiped out by a tsunami hundreds of years ago, some legends say parts of their city and remnants still stand underwater.

The banner still holds an ancient magic. When flown on a ship and the command word 'Aegir, Begone!' is spoken, the banner repels sea creatures, much like a *Protection vs. Evil* spell of the same name and protects everyone onboard the ship for one hour. This power can be summoned twice a day.

The Flooded Halls

GM's Note: All hallways and **Rooms #10-#21** (minus **Rooms #12** and **#18**) are completely filled with water and underwater rules apply. An abomination known as a Coral Golem continuously roams the passages in a circuit including **Room #10, #16, #17, and #19**. It attacks anything that is not a Histrix and bigger than 3' tall.

The Coral Golem resembles a 4' tall dwarf, complete with coral beard and seaweed clinging to random bits of rusted armor. It brandishes a harpoon.

Artist: Thomos Novosel



Coral Golem: AC 0, Move 6, HD 8, hp 60, THACO 13, Attack 1 or 2 (**Harpoon +1** 2d4 +3 to attack rolls, or 2 fists 1d8 +2 damage), Size M (4' tall), Morale 17, XP 2,000. Special: Paralysis, can't leave water, need +1 magic weapons to hit.

The Coral Golem uses its **Harpoon +1**, until targets enter melee range. It then begins to pummel with its fists. Each successful hit with its fists, the victim must make a save vs paralysis or be paralyzed for 1d4 rounds from the coral's tiny tentacles. The Coral Golem never leaves the water. Fighting the Coral Golem in its usual circuit has a 50% chance to attract nearby Histrix.

10. Alcoves: Several alcoves line the passage, each bearing a golden statue including a golden octopus, shark, mermaid, and a trident impaled into the ground. Barnacles, sea anemones, starfish and other sea life cling to the walls, floor and ceiling. Luminous jellyfish drift offering a faint glow throughout the passage.

- Each statue is worth 200 gp, and weigh approximately 30 lbs. each. The trident statue rests in front of the secret door.

Continued

- A school of barracuda enjoy the alcoves as their territory and attack those moving down the passage.

Monster: (9) Barracuda: AC 6, Move 12 (swimming), HD 2, hp 12 ea, THACO 19, Attack 1 (bite 2d4), Size S, Morale 12, XP 65 ea.

11. Guardroom: Kelp lines the walls like banners and several luminescent jellyfish float near the ceiling with thin, dangling tendrils. A decrepit table missing two legs lays against the east wall. Four Histrix are here, fashioning coral tipped spears and an impressive turtle shell shield.

- Bits of coral and weapon-making materials.
- Turtle shell functions as a medium shield, but on a natural 20, it breaks.

Monster: (4) Histrix: AC 4, Move 9 (land) 12 (swimming), HD 6, hp 46, 44, 42, 38, THACO 15, Attack 3/2 (by weapon), MR 25%, Size M, Morale 15, XP 975 ea. Special: *Project Force*, *Inertial Barrier* abilities. Each Histrix have tridents, daggers, 23 sp, and 3 gp. One guardsmen wears a silver armband (40 gp).

12. Peepholes: The crashing of waves gives a weird echo in this passageway.

- 2 Histrix are stationed here at all times, completely bored and have a 75% of sleeping while on duty.
- The secret doors are visible from the inside, but hidden on the outside.

Monster: (2) Histrix: AC 4, Move 9 (land) 12 (swimming), HD 5, hp 36 ea, THACO 15, Attack 1 (by weapon), MR 25%, Size M, Morale 15, XP 975 ea. Special: *Project Force*, *Inertial Barrier* abilities. Each Histrix have tridents, daggers, 8 sp, and 8 gp.

13. Kelp: The chamber is dark and full of floating kelp.

- The kelp obstructs vision to 3'.
- Lurking within the kelp are the pets of the high priestess: 2 large moray eels. They use the kelp to their advantage biting at random targets, and ducking back into the kelp. They bite every other round using this tactic. Characters fight at a -4 due to the kelp, reduced -2 if using small weapons (daggers, etc.).

Monster: (2) Moray Eels: AC 6, Move 12 (swimming), HD 5, hp 40, 34, THACO 15, Attack 1 (bite 3d6), Size L, Morale 11, XP 270 ea.

Treasure: Each eel has a collar of pearls around its neck (350 gp ea).

14. High Priestess Chambers: 50% chance high priestess is here or will be in **Room #21**. Kelp curtains act as a 'door' to this room. A thick, kelp bed lies in the northeast corner tucked inside a giant open clam shell. Several glowing jellyfish float near the ceiling, giving the room a dull glow. A smaller, closed clam shell sits next to the bed.

- The High Priestess attempts to flee immediately through the secret door to **Room #15** or **Room #13** depending on which way the party enters.
- The small clam acts as a chest. Inside is a silver coronet embedded with emeralds and pearls (1,500 gp), a trio of platinum arm bracelets (100 pp ea), garnet earrings shaped like jellyfish (75 gp), a ceremonial, shark handled dagger (50 gp), 200 sp, and 532 gp.

Monster: Syngnath, the High Priestess (Histrix): AC 4, Move 9 (land) 12 (swimming), HD 9, hp 64, THACO 11, Attack 1 (**Keelhauler** 1d8 +3 attack rolls), MR 25%, Size M, Morale 15, XP 3,000. Special: *Project Force*, *Inertial Barrier* abilities. Syngnath wields **Keelhauler**, a dagger, 42 gp, and 17 pp.

Spells: Level 1: *Animal Friendship (sea)*, *Cure Light Wounds*, *Entangle*, *Pro. From Good*, *Fear*, *Sanctuary*
Level 2: *Charm*, *Enthrall*, *Hold Person*, *Silence 15'* radius, *Wyvern Watch* **Level 3:** *Dispel Magic*, *Snare*, *Spike Growth*, **Level 4:** *Animal Summoning I (sea)*, *Free Action* **Level 5:** *Cure Critical Wounds*

Keelhauler

Keelhauler is a bizarre spear created from fused coral and barnacles and acts as a **Spear +2**. Kelp twine serves as hand grips. On a successful attack roll of 18 or higher, **Keelhauler** stuns opponents for 1 round, unless a successful saving throw vs. paralyzation is made. However, the paralyze ability only functions underwater. If **Keelhauler** is kept outside of water for over a day, it disintegrates into a fine reddish powder. Immersing **Keelhauler** in seawater for one full turn keeps the spear from disintegrating.

15. Guards: Sparsely furnished, this room contains two piles of kelp and a few barnacle hooks on the walls.

- This is the quarters of the Syngnath's bodyguards. They spar each other if not on alert.

(2) Histrix Bodyguards: AC 4, Move 9 (land) 12 (swimming), HD 7, hp 50 ea, THACO 13, Attack 3/2 (trident 1d6+1, +2 to attack rolls), MR 25%, Size M, Morale 16, XP 1,400 ea. Special: *Project Force*, *Inertial Barrier* abilities. Each Histrix has tridents, daggers, 20 gp, and 5 pp.

The Grotto

GM's Notes: The Grotto covers **Rooms #16, #17, and #21**. These areas are a place of wonder—luminescent jellyfish float everywhere, colorful starfish, sea urchins, anemones cling to rocks, floors, and walls, and mussels, barnacles and clams are scattered throughout. Multi-colored fish swim in and out and between rocks and seaweed. Anyone attempting to walk barefoot through this area suffers 1d3 damage per round. The water ranges in depth from 10' to 20' deep. The Coral Golem patrols through **Room #16** and **#17**.

16. Jellyfish Grotto: The northwest corner of this immense chamber has a massive collection of colorful jellyfish with long, dangling tendrils floating from floor to ceiling which block vision beyond a few yards. A sizable turtle swims gently by, searching for food through the multi-colored hued rocks and coral. The grotto continues off to the east.

- The jellyfish are stun jellies; anyone swimming through the area or tunnel beyond need to make a saving throw vs. paralyzation or be stunned for 1 turn and take 1 hp of damage per turn as the jellyfish slowly feed.
- Next to the entrance of the tunnel, on the cavern's floor is a staff with an octopus head carved on its top and tentacles interwoven into the shaft. The staff is magical and repels jellyfish (giant varieties get a saving throw at +4), allowing access through the tunnel and to the sea beyond.

17. Histrix Grotto: Seahorse humanoids frolic and swim about this breathtaking grotto. Luminescent jellyfish float about the room and a variety of fish swim about, creating a kaleidoscope of colors and a feeling of tranquility. Kelp has been gathered into beds in different areas of the underground reef.

- There are a total of 13 Histrix in this room. 8 Histrix immediately attack. 3 males attempt to flee through **Room #16** and out the tunnel as they are carrying eggs. 1 Histrix attempts to flee to **Room #21** to warn the others who arrive in 5 + 1d6 rounds.

Monster: (8) Histrix: AC 4, Move 9 (land) 12 (swimming), HD 5, hp 30 ea, THACO 15, Attack 1 (by weapon), MR 25%, Size M, Morale 15, XP 975 ea. Special: *Project Force*, *Inertial Barrier* abilities. Each Histrix have tridents or spears, daggers, 12 sp, and 2 gp.

18. Pirate Loot: A jagged, 20' high cliff leads to a dry platform. A skeleton lies against the wall, connected to it by dry seaweed and algae. A cobwebbed chest lies next to the skeleton.

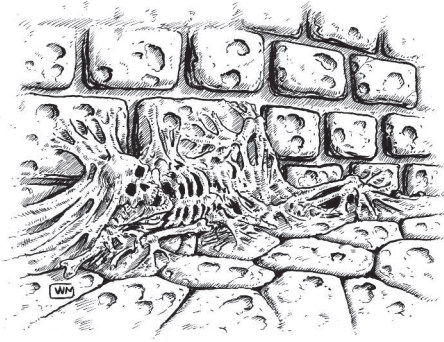

Artist: William McAusland

- The cliff has numerous dry handholds and does not require a roll to climb.
- **Trap:** The chest has a poison needle trap. Save vs. poison or take 15 damage.
- Inside the chest is a splattering of coins, 400 cp, 322 sp, 200 ep, and 112 gp. A small leather sack holds 5 ametrines (75 gp ea) and a gold bracelet inscribed 'To my beloved Darla' (130 gp). Three potions are tucked in amidst the coins: **Healing**, **Water Breathing**, and **Oil of Impact**.
- A scroll case holds the damaged remains of a Captain's Log.

19. Shells: The floor of this chamber is covered in a variety of shapes, sizes, and colored shells. The walls have murals of underwater scenes with merfolk and different sea creatures. Three Ghuhudan corpses lay on the northwestern chamber's floor, where one Histrix is sucking out the insides of a fallen Ghuhudan through its snout. Several other Histrix are huddled over a section of the seafloor near the middle.

- The Histrix have created a battle map of the dry areas of the sea fort (**Areas #4-6 and #8**) to strategize against the Ghuhudan.
- The Ghuhudan corpses have been punctured in numerous places and their insides devoured by the Histrix.

Monster: (5) Histrix: AC 4, Move 9 (land) 12 (swim), HD 5, hp 30 ea, THACO 15, Attack 1 (by weapon), MR 25%, Size M, Morale 15, XP 975 ea. Special: *Project Force*, *Inertial Barrier* abilities. Each Histrix have tridents or spears, daggers, 1d12 sp, and 1d4 gp.

20. Prisoners: Rusty shackles line the walls of this chamber. Clumps of seaweed and small fish dart before several different humanoids chained to the walls. A large, red colored Histrix wearing a gemmed mask is engaged in torturing a limp, barely-conscious sahuagin.

Monster: (1) Jailor (Histrix): AC 4, Move 9 (land) 12 (swimming), HD 8, hp 55, THACO 13, Attack 3/2 (spear 1d8 +3 to attack rolls), MR 25%, Size M, Morale 15, XP 1,400. Special: *Project Force*, *Inertial Barrier* abilities. The jailor has a spear, a dagger, 24 gp, 3 pp, and a citrine embedded mask (300 gp).

- Prisoners include: 5 drowned Ghuhudan, 1 half-dead sahuagin (hp 2), and 2 tritons (Jinnis and Khonvos) AC 5, HD 3 hp 7 (19), 10 (17).
- The tritons want to flee the sea fort, but if healed, could be talked into helping the party.
- If characters are captured, they are brought here (and will drown unless they have a way to breathe).

21. Grotto of Ceremonies: *If the Histrix moved to Room #17 during an alarm, this area may be relatively empty except the merman. If no alarm has sounded, Syngnath has a 50% to be here, conducting the sacrifice alongside Sarellis.*

A massive grotto with a dry platform, 10' high, runs along the east wall. On the platform, lies a stone slab. A squirming merman lies atop it, fighting against his shackles, while one seahorse humanoid raises a ceremonial dagger. Several seahorse humanoids gather below the platform, their heads above the water's surface to watch the proceedings.

The merman is Narious, Velmous's lover, and will be grateful if rescued.

- A chest lies on the platform, against the east wall. It holds ceremonial items and include a silver platter (25 gp), 3 ceremonial daggers (10 gp ea), a strange hat made from a manta ray, and a pouch with **Dust of Dryness**.

Monster: (5) Histrix: AC 4, Move 9 (land) 12 (swimming), HD 5, hp 33 ea, THACO 15, Attack 1 (by weapon), MR 25%, Size M, Morale 15, XP 975 ea. Special: *Project Force*, *Inertial Barrier* abilities. Each Histrix have tridents or spears, daggers, 8 sp, and 9 gp.

(1) Acolyte Priestess, Sarellis (Histrix): AC 4, Move 9 (land) 12 (swimming), HD 5, hp 37, THACO 15, Attack 1 (by weapon), MR 25%, Size M, Morale 15, XP 975 ea. Special: *Project Force*, *Inertial Barrier* abilities. *Daughter of Syngnath, Sarellis wants to take her mother's position as leader one day.* Sarellis is equipped with a spear, **Bracers of the Squid**, and 27 gp, 14 pp.

Spells: Level 1: *Bless*, *Command*, *Cure Light Wounds*, *Darkness*, *Faerie Fire*, **Level 2:** *Aid*, *Hold Person*, *Silence 15' Radius*, *Spiritual Hammer*, *Withdraw*, **Level 3:** *Magical Vestment*

Bracers of the Squid

These bizarre bracers seem to be made of rubbery, purple tentacles that wrap around the wearer's wrists. When the wearer concentrates, the tentacle can lash out up to 12', grasping outcroppings like a whip, or using its hundreds of miniature suction cups to stick to hard surfaces. The tentacles can support up to 400 lbs. of weight and could be used to swing from treetops or swing over pits, climb walls, or disarm foes. The bracers can also be used as a whip, dealing 1d3 damage and potentially entangling the target, much like a regular whip. If both are used at the same time, then the wearer fights at -2/-4. Delivering 15 damage to a tentacle severs it and destroys a bracer.

Conclusion

Successfully clearing out the Histrix leads the Ghuhudan to happily move into the dry areas of the sea fort. They live peacefully with the nearby town of Mjova and may even set up trade.

If Narious and Velmous are reunited, they thank the party profusely. They offer a medallion shaped as a dolphin (50 gp) and claim it can be used to summon a dolphin to help in times of trouble.

The residents of Mjova will be happy to hear of the events and plan to send a new lighthouse warden to Lokom's Beacon. If the party helped the crew of the Red Tempest, most of the pirates lingering about town will demonstrate a grudging respect for the party. If it's learned that the party killed the crew, other pirates may seek revenge.

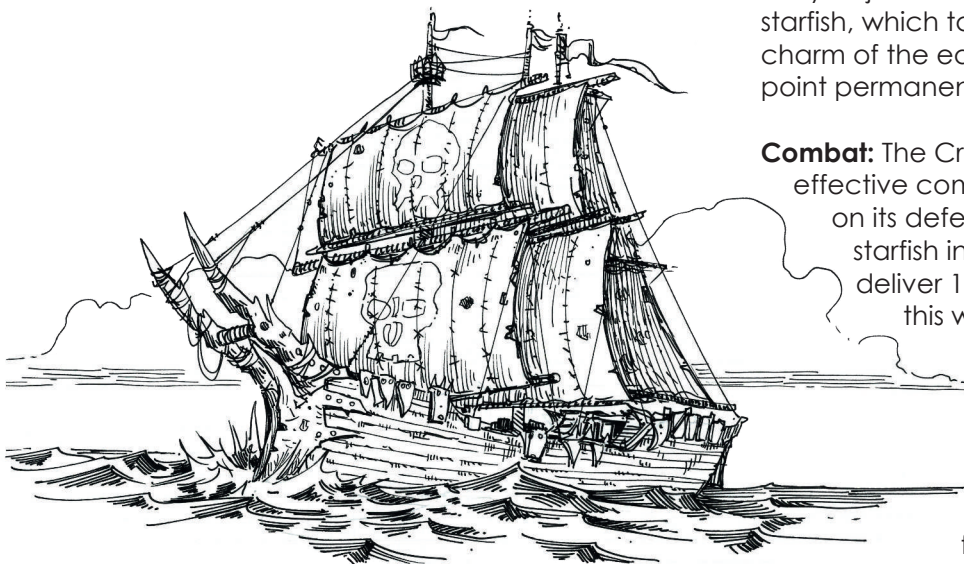

Artist: Maciej Zagorski-The Forge

New Monsters

Crown of Thorns Starfish

Climate/Terrain: Ocean, sea coasts, bays, coastal beaches

Frequency: Very Rare

Number Appearing: 1

Organization: Solitary

Activity Cycle: Any

Intelligence: 11-12

Treasure: A (lair)

Alignment: Neutral Evil

Armor Class: 4 (body) 6 (arms)

Movement: 3

Hit Dice: 10

THACO: 11

Attack: N/A

Saving Throws: as 10th+ level Fighter

Special Traits: Domination, regeneration

Magic Resistance: 0%

Size: L

Morale: 15-16

Experience: 2,000

The Crown of Thorns Starfish is a multi-armed, thorn covered, purplish to dark blue starfish that can have up to 20 arms (https://en.wikipedia.org/wiki/Crown-of-thorns_starfish#Description). They can become large, covering a 10' radius. They move by using their prehensile arms and grasping the seafloor bottom or rocks. They are carnivorous, preying on fish, barnacles and other sea life but consume food very slowly. The Crown of Thorns Starfish enjoys dominating humanoids and fish to act as its slaves and servants. Most often, it controls others to deliver food and to surround it with shiny objects. Rumors tell that eating the brain of the starfish, which tastes awful, increases the natural charm of the eater, increasing their Charisma by one point permanently.

Combat: The Crown of Thorns is too slow to be an effective combatant and, in melee, relies on its defensive mechanisms. Anyone striking the starfish in melee releases venomous thorns that deliver 1d4 damage. A foe taking damage this way must also make a saving throw vs poison is needed or take an additional 1d6 damage. The starfish's most potent ability is its *Domination* ability, which works identically to the wizard's spell. The starfish focuses on ranged attackers first with its *Domination* ability.

However, it can only control as many individuals as it has arms. Each arm has 10 hp before becoming severed, which releases an individual. The Crown of Thorns regenerates one arm per day, up to its maximum of 20 arms.

Histrix

Climate/Terrain: Ocean, sea coasts, bays, coastal beaches

Frequency: Rare

Number Appearing: 1d12

Organization: Tribe

Activity Cycle: Any

Intelligence: 13-14

Treasure: D (lair), M (individual)

Alignment: Neutral to Chaotic Evil

Armor Class: 4

Movement: 9 (land) 12 (swimming)

Hit Dice: 5+

THACO: 15

Attack: 1, by weapon

Saving Throws: as 5th+ level Fighter

Special Traits: Camouflage, some psionic ability

Magic Resistance: 25%

Size: M

Morale: 15

Experience: 975

Histrix are a race of sea dwelling creatures that look like man-sized seahorses. They have two scaly arms and webbed hands that can grip weapons and tools. Histrix have no legs, but rather slither on their elongated, serpentine bodies and prehensile tails. Their bodies are completely covered with tiny thorns with dark tips which surround the forehead forming a natural coronet. Their nose is a long and tapered snout with one or more thin white lines. The color of their bodies is markedly variable and can match their surroundings over time. There have been rumors of black Histrix, but they seem to be extremely rare. Histrix favor adorning themselves in jewelry made of all varieties of gemstones and seashells.



Artist: Thomas Novosel

Histrix males carry and brood their eggs in a ventral brood pouch. When fully grown, the pups emerge from the pouch and evolve in complete autonomy. Histrix usually serve a female leader, usually a priestess, and guard her to the death. Histrix seek reefs, coral, and underwater grottoes as their lairs. While Histrix understand common languages, they use telepathy in their own language, occasionally making strange trumpeting noises while in combat..

Combat: Histrix favor spears and tridents in combat, as they are easier to wield underwater. Histrix are very intelligent and use terrain to their advantage as well as working together against their enemies. Histrix are able to use their tail to attach themselves to rocks or seaweed to be able to fight upside down or withstand currents while fighting. Anyone grappling with a Histrix receive 1d3 damage per round from their thorns. While Histrix have a camouflage ability, it takes at least 1 turn for their coloration to change. If prepared and camouflaged, they have a 60% to be hidden and may attack with surprise. Histrix also possess limited strange powers that resemble psionics, however they are limited to *Telepathy*, *Project Force* and *Inertial Barrier* with notable differences. Their *Project Force* has a maximum range of 100 feet, deals 1d8+2 damage, can be their only action for that round, and can only be used 3x per day. The *Inertial Barrier* looks more like a water bubble and only covers the caster. The *Inertial Barrier* can be used 3x per day and it lasts for 6 +1d4 rounds.

Ghuhudan

Artist: Nathan Atterbery

Climate/Terrain: Ocean, sea coasts, bays, coastal beaches, reefs

Frequency: Uncommon

Number Appearing: 1d12

Organization: Tribe

Activity Cycle: Any

Intelligence: 8-10

Treasure: B (lair), O (individual)

Alignment: Neutral Good

Armor Class: 6

Movement: 9 (land), 18 (swimming)

Hit Dice: 4+

THACO: 17

Attack: 1, by weapon

Saving Throws: As 4th+ level Fighter

Special Traits: +2 vs. cold attacks

Magic Resistance: N/A

Size: L (8')

Morale: 11

Experience: 270



Ghuhudan are strange, bulky, creatures which resemble humanoid elephant seals. Average Ghuhudans can grow up to 8' tall and weigh over 1,300 pounds. Their coloration ranges from black, to dark brown, to a pale gray. Ghuhudan communicate in their own language, which sounds like sea lions. However, they also are able to inflate their proboscises, creating a series of deep intimidating sounds for warnings or in combat. Ghuhudan are able to speak a broken Common that can be difficult for some to understand.

Ghuhudan are peaceful and a passive race that tend towards isolation, living along rocky shores and in sea caves. They are hunter/gatherers, enjoying fishing as well as treating themselves to bird eggs which they find a delicacy. Ghuhudan have also learned a technique of weaving huge strands of kelp together to create floating 'islands'. These islands take an extraordinarily amount of effort and time to build but are very buoyant and surprisingly sturdy. Small groups of adventurous families make floating islands and use them to drift in the sea, fishing as they go, in search for their next tasty bird egg hunting ground. Aquatic by nature, Ghuhudan can hold their breath for 2 hours underwater.

Combat: Although peaceful, Ghuhudan are fearless and defend themselves, their kin, and homes ferociously when threatened. Due to this fierce nature, Ghuhudan receive an extra +1 to all attack rolls. They favor daggers and gaff hooks (1d6 damage) in combat, which they often make from barnacles, shells, and other natural materials. Their tough, calloused skin provides a natural AC 6. Ghuhudan prefer to fight in water where they have more maneuverability.

Sand King Crawler

Climate/Terrain: Ocean, sea coasts, bays, coastal beaches, reefs

Frequency: Very Rare

Number Appearing: 1

Organization: Solitary

Activity Cycle: Any

Intelligence: 2-4

Treasure: D

Alignment: Neutral

Armor Class: 2

Movement: 6 (land), 18 (swimming)

Hit Dice: 8

THACO: 13

Attack: 3 (2 claws 2d8, and bite 3d8)

Saving Throws: As 8th+ level Fighter

Special Traits: Swallow whole

Magic Resistance: 0%

Size: H (20')

Morale: 14

Experience: 1,400

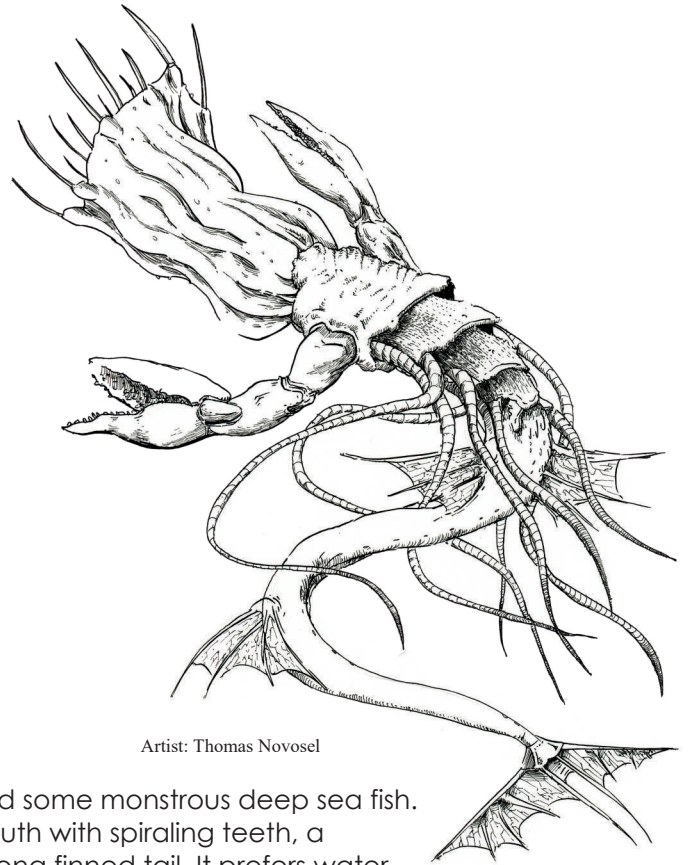

Artist: Thomas Novosel

This strange beast looks like a combination of a crayfish and some monstrous deep sea fish.

A Sand King Crawler has a hood-like head with a huge mouth with spiraling teeth, a heavily armored mid-thorax with tentacle 'feelers', and a long finned tail. It prefers water with a depth of 100' but has also been known to bury itself in beaches as it waits for prey to come close. A Crawler's 'feelers' help it feel vibrations on the sand or water movements when in water, so the Crawler is very difficult to surprise. An agile swimmer, it prefers eating seals and other larger sea life though Crawlers are not known to be terribly picky. The rumor of a Sand King Crawler attacking small vessels is not unheard of. Any accumulated treasure from its victims is usually found inside it, as its stomach acids are very slow to digest meals.

Combat: A Sand King Crawler's mouth is elastic and acts almost like a net, spreading open revealing spiral rows of razor sharp teeth, before clamping closed on its target. On a natural attack roll of 18 or better, the Crawler has a chance to swallow its prey. Crawlers tend to prefer to bite would-be prey, using their claws to hold prey in place and bring them closer to its maw.

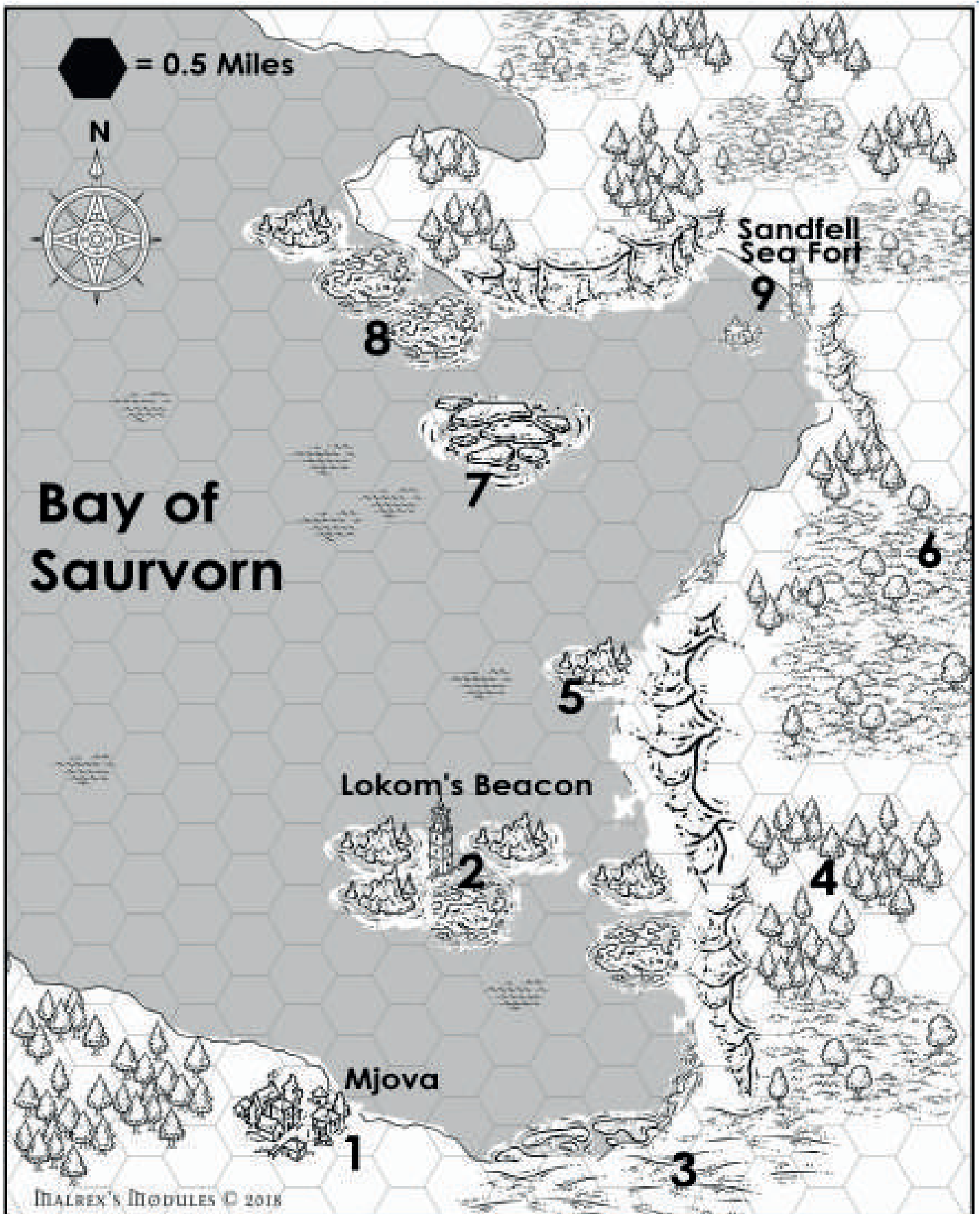

LOKOM'S BEACON

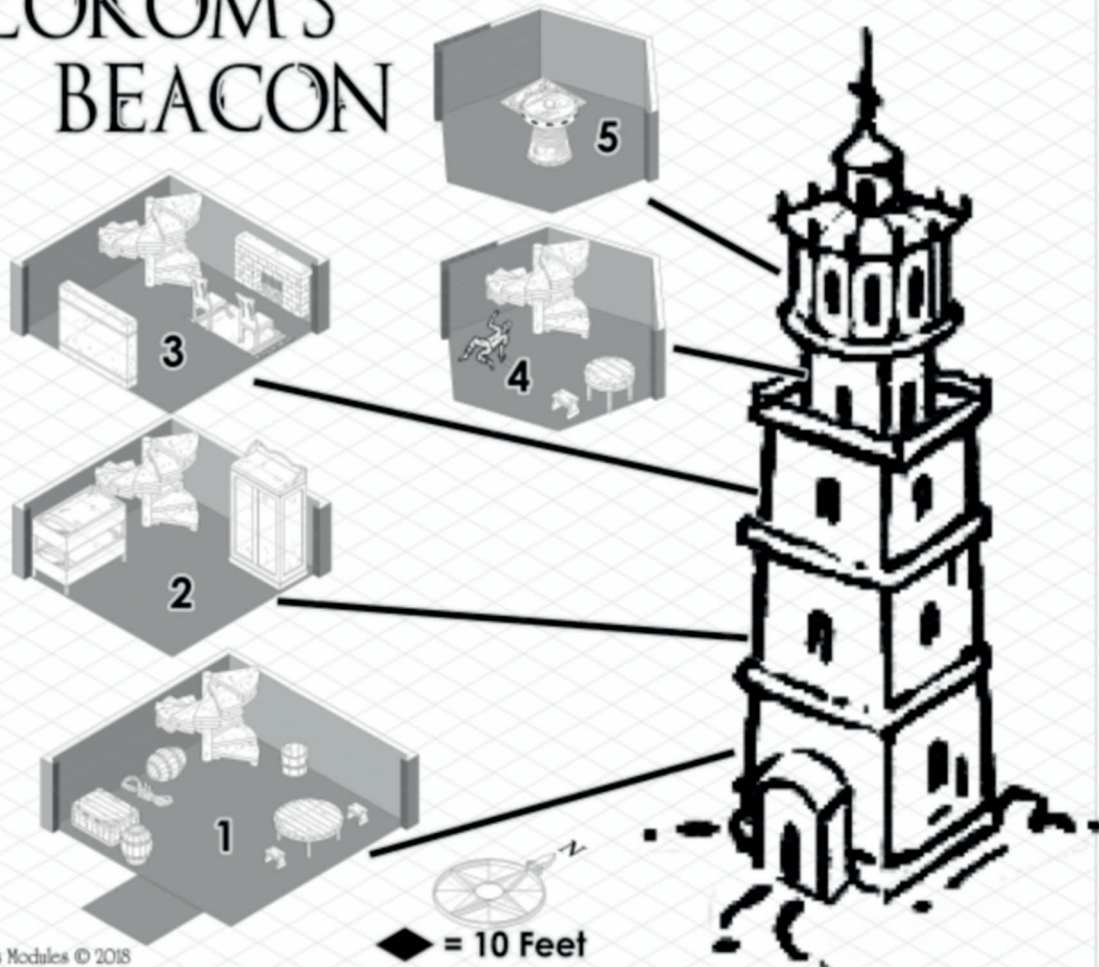

Malrex's Modules © 2018

CROWN-OF-THORNS STARFISH LAIR

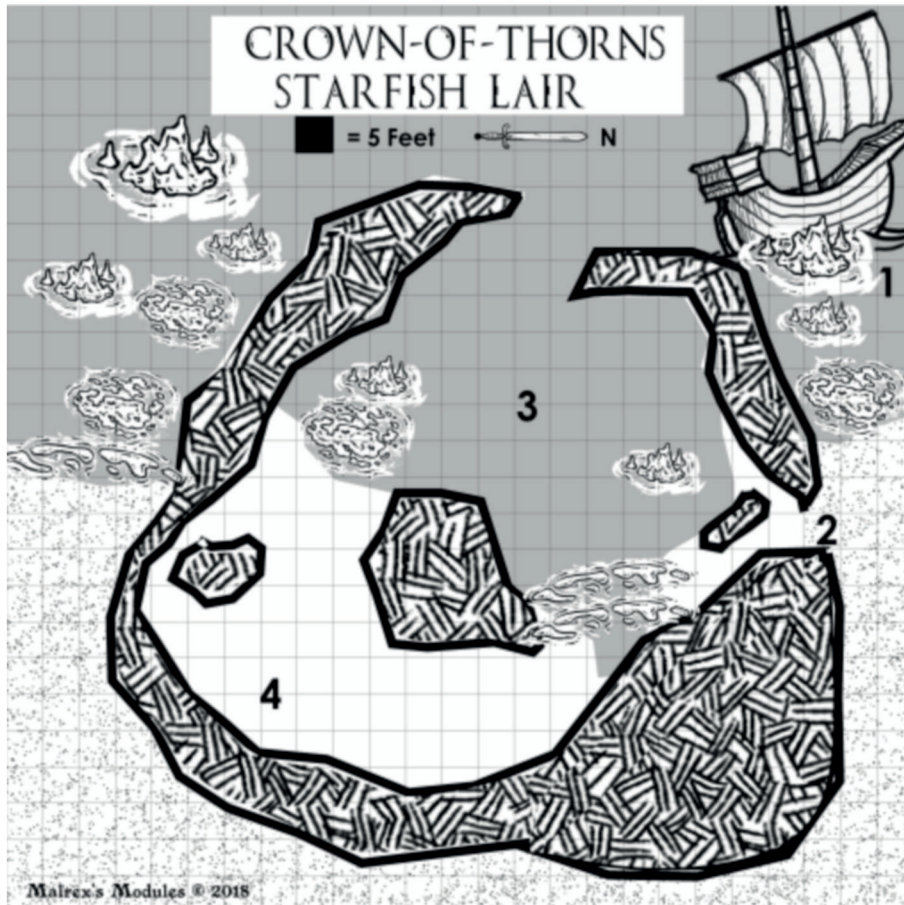

Malrex's Modules © 2018

The Jolly Merchant (a.k.a. The Red Tempest)

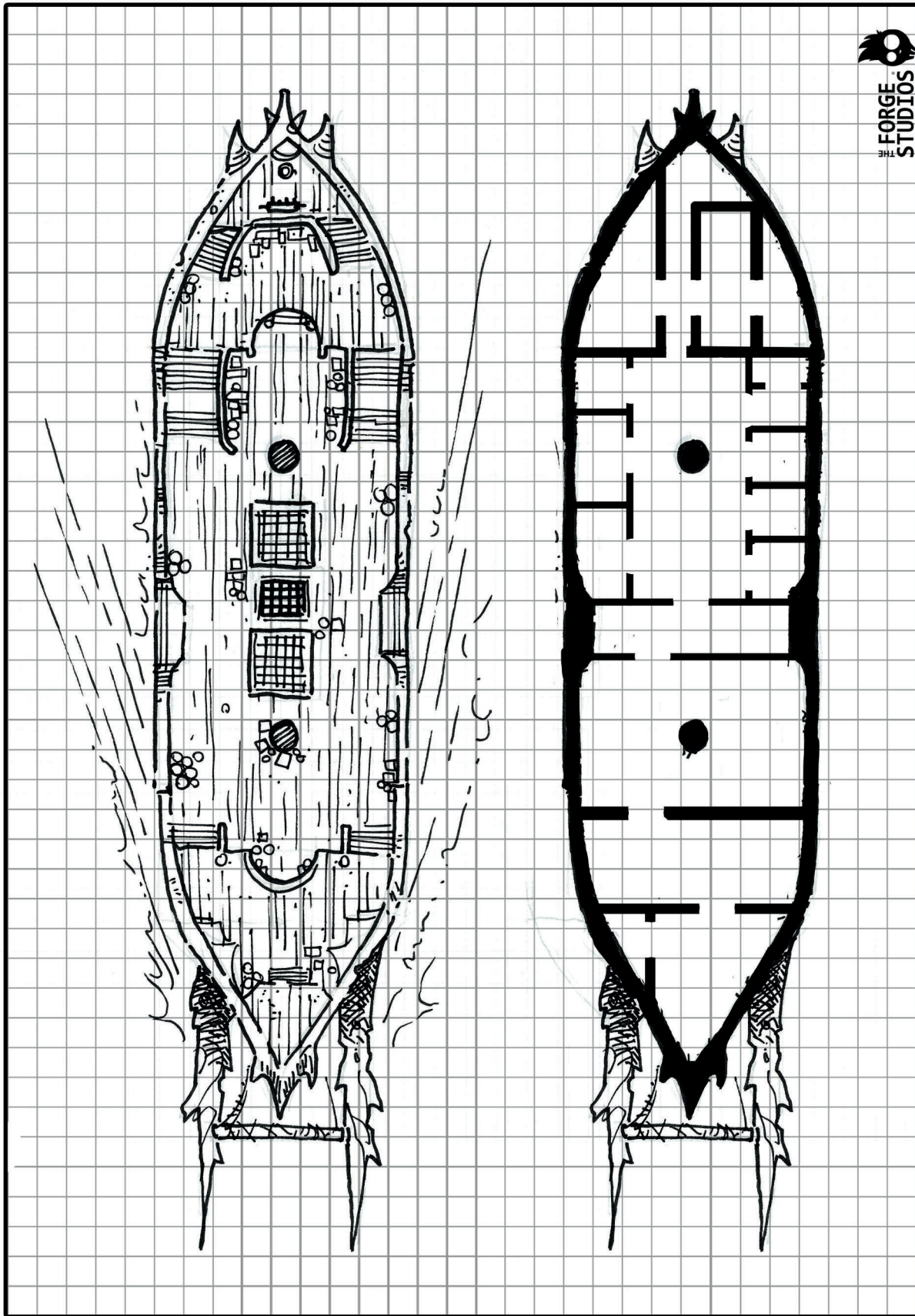

Each hex = 3 Feet

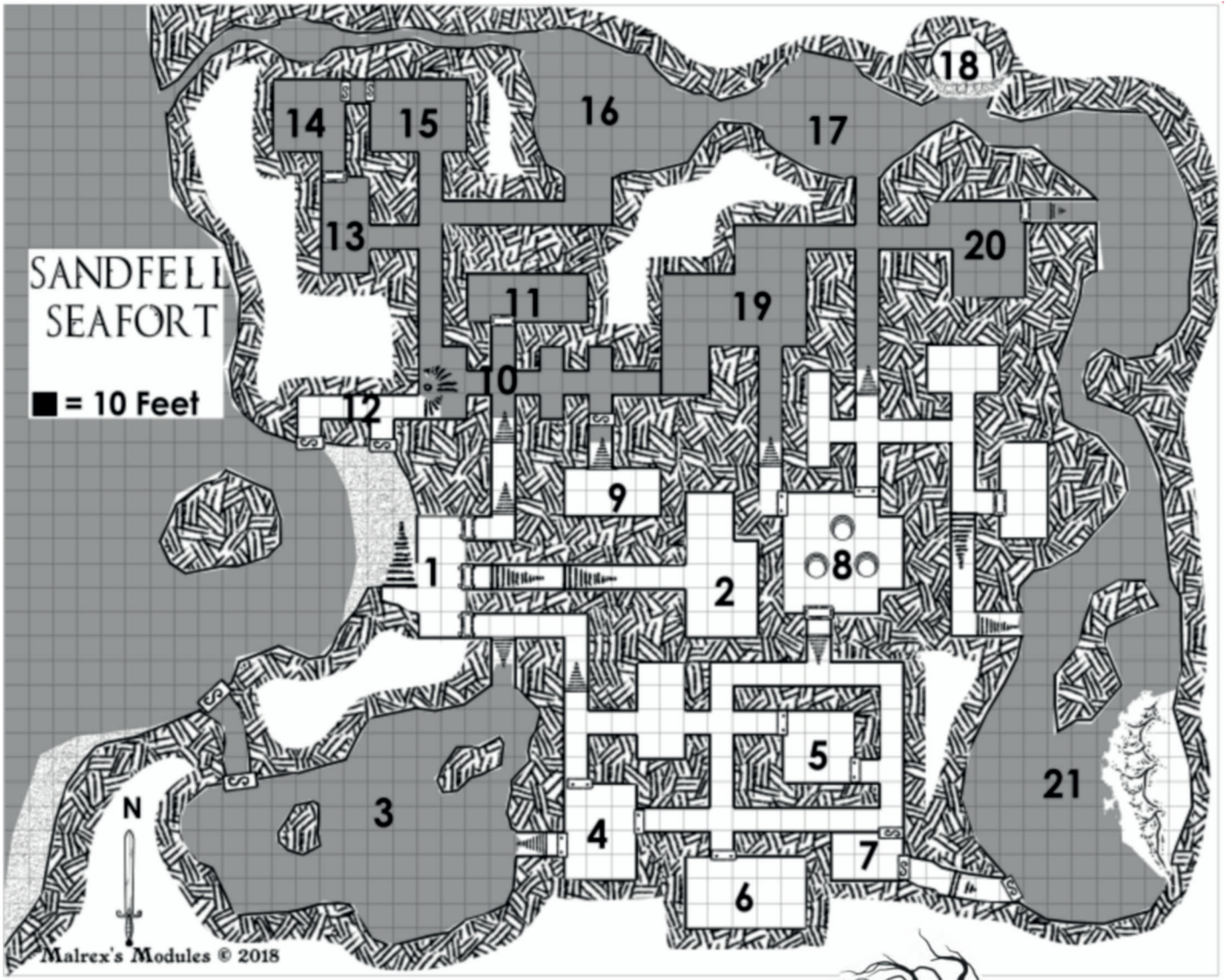

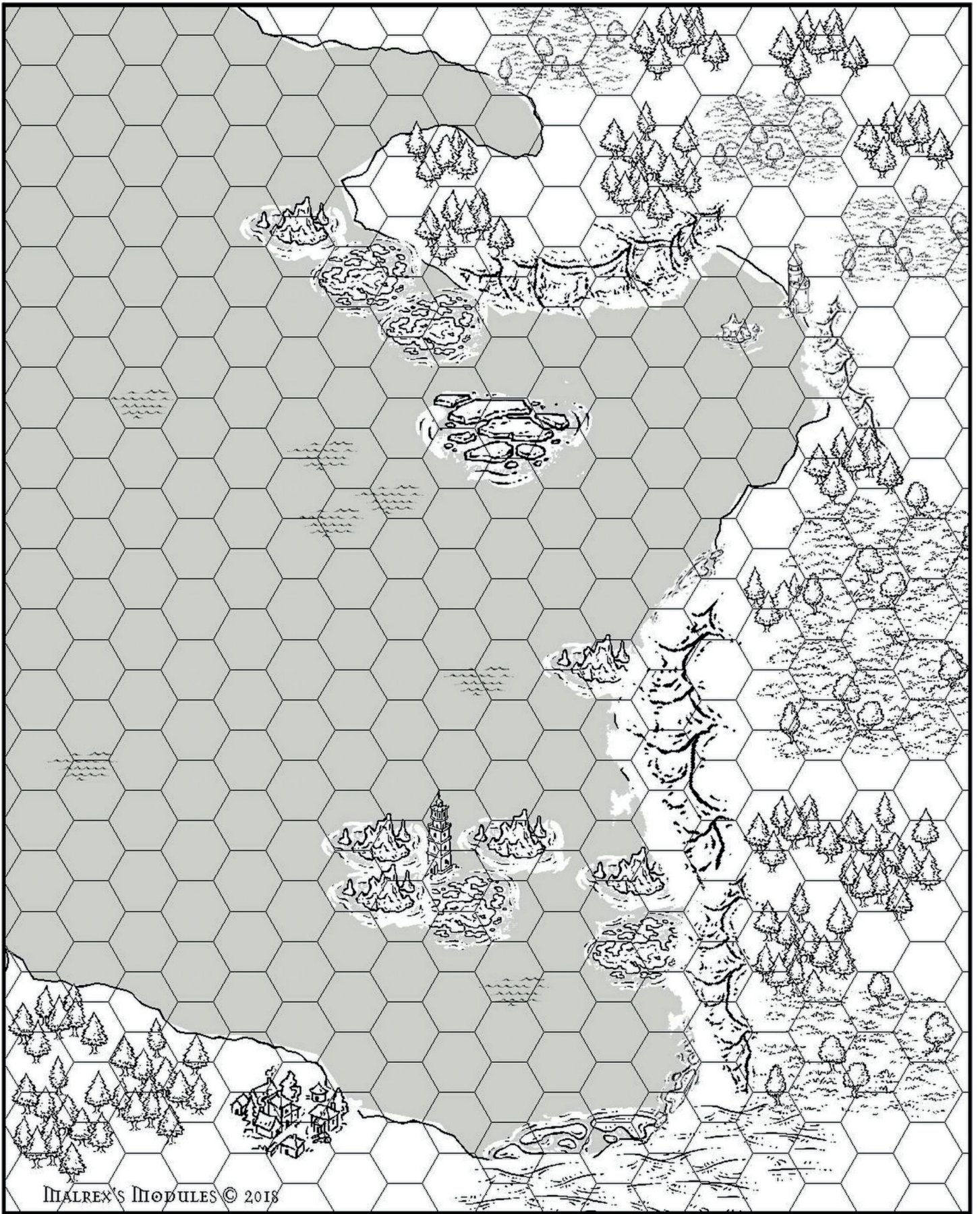

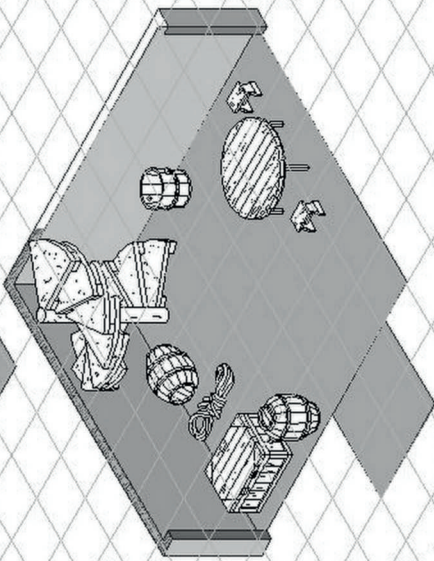
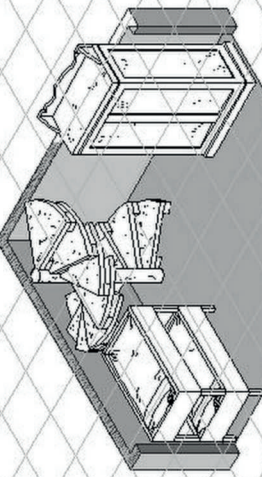
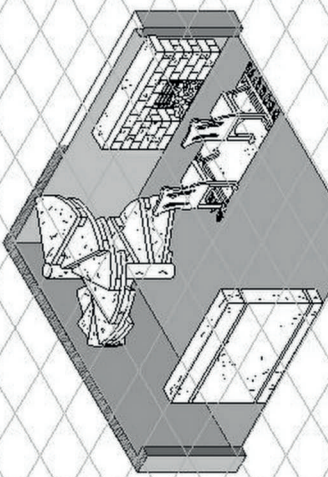
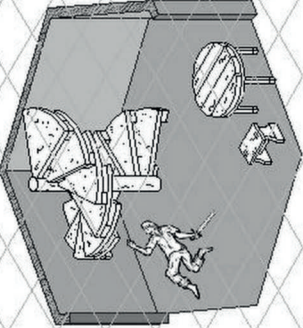
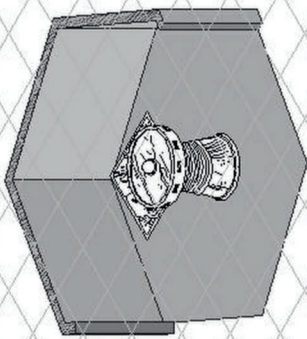
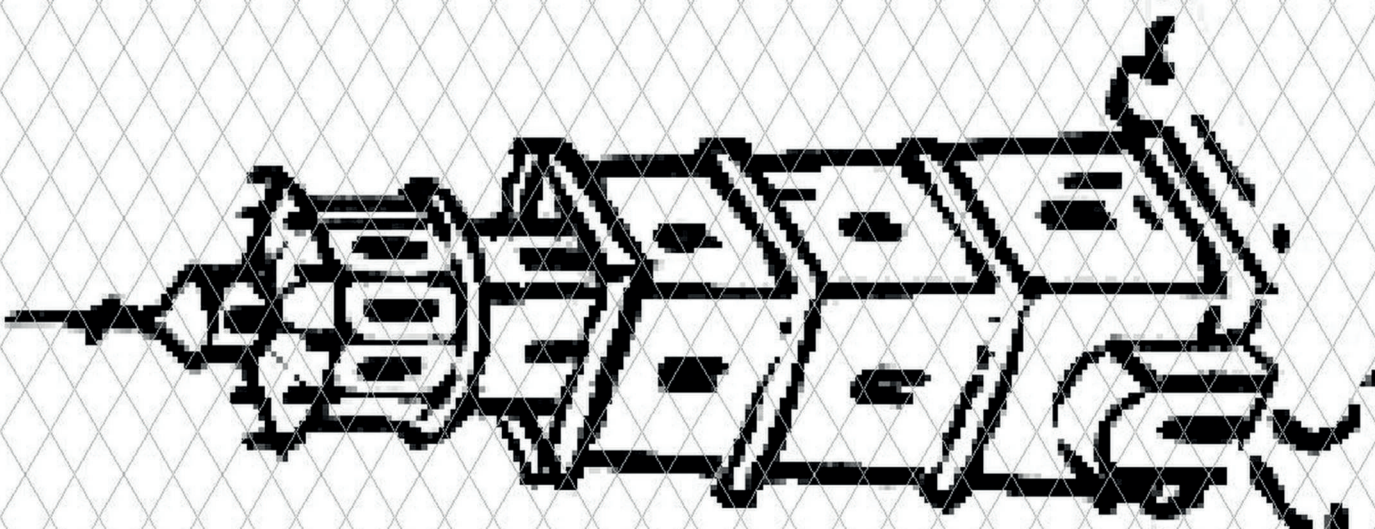

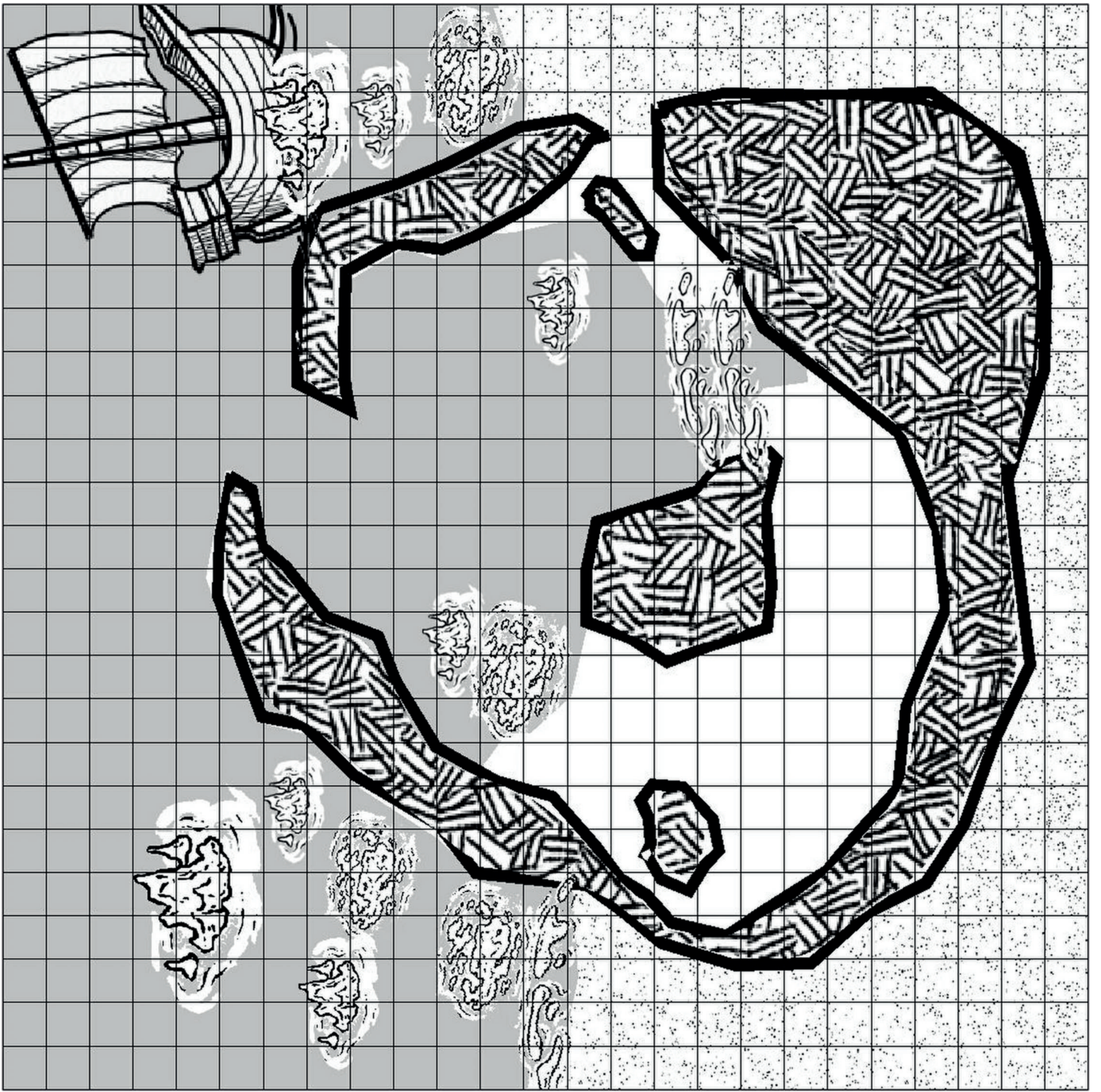

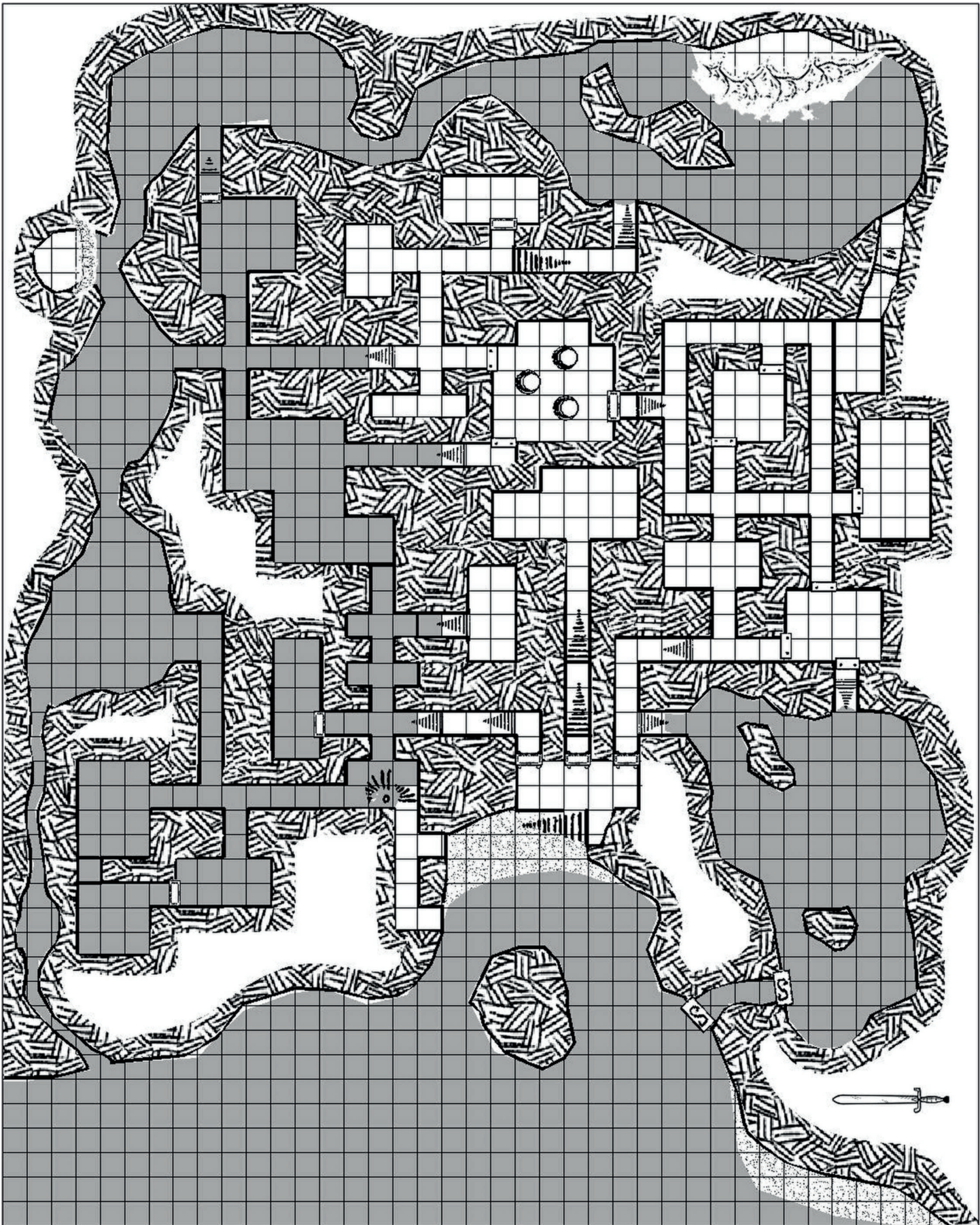

LEGAL

No portion of this document, Standoff at Seafell Se Fort, can be published, sold, or duplicated in any format without the express written permission from Aaron Fairbrook "Malrex" and The Merciless Merchants © 2018.

Product Identity: The following items are designated Product Identity, as defined in Section 1(e) of the Open Game License Version 1.0a, and are subject to the conditions set forth in Section 7 of the OGL, and are not Open Game Content: all trademarked items, all artwork and diagrams, dialogue, plots, storylines, locations, characters, logos, and trade dress. Items previously designated as Open Game Content or are in the public domain do not fall under this designation of Product Identity.

Open Content: Except for material designated as Product Identity (see above), the game mechanics of this game product and are Open Game Content, as defined in the Open Game License version 1.0a Section 1(d). No portion of this work other than the material designated as Open Game Content may be reproduced in any form without written permission.

OPEN GAME LICENSE Version 1.0a

The following text is the property of Wizards of the Coast, Inc. and is Copyright 2000 Wizards of the Coast, Inc ("Wizards"). All Rights Reserved.

1. Definitions:

- (a) "**Contributors**" means the copyright and/or trademark owners who have contributed Open Game Content;
- (b) "**Derivative Material**" means copyrighted material including derivative works and translations (including into other computer languages), potation, modification, correction, addition, extension, upgrade, improvement, compilation, abridgment or other form in which an existing work may be recast, transformed or adapted;
- (c) "**Distribute**" means to reproduce, license, rent, lease, sell, broadcast, publicly display, transmit or otherwise distribute;
- (d) "**Open Game Content**" means the game mechanic and includes the methods, procedures, processes and routines to the extent such content does not embody the Product Identity and is an enhancement over the prior art and any additional content clearly identified as Open Game Content by the Contributor, and means any work covered by this License, including translations and derivative works under copyright law, but specifically excludes Product Identity.
- (e) "**Product Identity**" means product and product line names, logos and identifying marks including trade dress; artifacts; creatures characters; stories, storylines, plots, thematic elements, dialogue, incidents, language, artwork, symbols, designs, depictions, likenesses, formats, poses, concepts, themes and graphic, photographic and other visual or audio representations; names and descriptions of characters, spells, enchantments, personalities, teams, personas, likenesses and special abilities; places, locations, environments, creatures, equipment, magical or supernatural abilities or effects, logos, symbols, or graphic designs; and any other trademark or registered trademark clearly identified as Product Identity by the owner of the Product Identity, and which specifically excludes the Open Game Content;
- (f) "**Trademark**" means the logos, names, mark, sign, motto, designs that are used by a Contributor to identify itself or its products or the associated products contributed to the Open Game License by the Contributor
- (g) "**Use**", "**Used**" or "**Using**" means to use, Distribute, copy, edit, format, modify, translate and otherwise create Derivative Material of Open Game Content.
- (h) "**You**" or "**Your**" means the licensee in terms of this agreement.

2. The License

This License applies to any Open Game Content that contains a notice indicating that the Open Game Content may only be Used under and in terms of this License. You must affix such a notice to any Open Game Content that you Use. No terms may be added to or subtracted from this License except as described by the License itself. No other terms or conditions may be applied to any Open Game Content distributed using this License.

3. Offer and Acceptance

By Using the Open Game Content You indicate Your acceptance of the terms of this License.

4. Grant and Consideration

In consideration for agreeing to use this License, the Contributors grant You a perpetual, worldwide, royalty-free, non-exclusive license with the exact terms of this License to Use, the Open Game Content.

5. Representation of Authority to Contribute

If You are contributing original material as Open Game Content, You represent that Your Contributions are Your original creation and/or You have sufficient rights to grant the rights conveyed by this License.

6. Notice of License Copyright

You must update the COPYRIGHT NOTICE portion of this License to include the exact text of the COPYRIGHT NOTICE of any Open Game

Content You are copying, modifying or distributing, and You must add the title, the copyright date, and the copyright holder's name to the COPYRIGHT NOTICE of any original Open Game Content you Distribute.

7. Use of Product Identity

You agree not to Use any Product Identity, including as an indication as to compatibility, except as expressly licensed in another, independent Agreement with the owner of each element of that Product Identity. You agree not to indicate compatibility or co-adaptability with any Trademark or Registered Trademark in conjunction with a work containing Open Game Content except as expressly licensed in another, independent Agreement with the owner of such Trademark or Registered Trademark. The use of any Product Identity in Open Game Content does not constitute a challenge to the ownership of that Product Identity. The owner of any Product Identity used in Open Game Content shall retain all rights, title and interest in and to that Product Identity.

8. Identification

If you distribute Open Game Content You must clearly indicate which portions of the work that you are distributing are Open Game Content.

9. Updating the License

Wizards or its designated Agents may publish updated versions of this License. You may use any authorized version of this License to copy, modify and distribute any Open Game Content originally distributed under any version of this License.

10. Copy of this License

You MUST include a copy of this License with every copy of the Open Game Content You Distribute.

11. Use of Contributor Credits

You may not market or advertise the Open Game Content using the name of any Contributor unless You have written permission from the Contributor to do so.

12. Inability to Comply

If it is impossible for You to comply with any of the terms of this License with respect to some or all of the Open Game Content due to statute, judicial order, or governmental regulation then You may not Use any Open Game Material so affected.

13. Termination

This License will terminate automatically if You fail to comply with all terms herein and fail to cure such breach within 30 days of becoming aware of the breach. All sublicenses shall survive the termination of this License.

14. Reformation

If any provision of this License is held to be unenforceable, such provision shall be reformed only to the extent necessary to make it enforceable.

15. COPYRIGHT NOTICE

Open Game License v 1.0a Copyright 2000, Wizards of the Coast, Inc.
System Reference Document Copyright 2000-2003, Wizards of the Coast, Inc.; Authors Jonathan Tweet, Monte Cook, Skip Williams, Rich Baker, Andy Collins, David Noonan, Rich Redman, Bruce R. Cordell, John D. Rateliff, Thomas Reid, James Wyatt, based on original material by E. Gary Gygax and Dave Arneson.
Labyrinth Lord™ © 2007-2009 Goblinoid Games; Author Daniel Proctor
Labyrinth Lord™ Advanced Edition Companion © 2009-2010 Goblinoid Games; Author Daniel Proctor
OSRIC™ Chapter I Copyright 2006-08 by Stuart Marshall. Additional authors: Trent Foster, James Boney, Vincent Fruge, Chris Hopkins, Robert Ross, Jeremy Goehring, Mike Davison, Daniel Proctor, B. Scot Hoover, Chris Cain, Bill Silvey, Floyd Canaday, Mathew James Stanham.
For Gold & Glory, Copyright 2014, Justen Brown
Standoff at Sandfell Sea Fort, Copyright 2014, "Malrex"--Aaron Fairbrook

Malrex's Modules



COME STEAL THE DEAL!!

If you enjoyed this adventure, please consider supporting me on Patreon. One new OSR ruleset adventure per month for only 1\$. You can also see the creative process on Instagram @Malrexmodules. Thanks for your support!

<https://www.patreon.com/malrexmodules>

Also....

Check out The Merciless Merchant products at DrivethruRPG.

<https://www.drivethrurpg.com/browse/pub/11180/The-Merciless-Merchants>

Or get the best deals at our own store: [Themercilessmerchants.com/shop](https://www.themercilessmerchants.com/shop)



“Standoff at Sandfell Sea Fort” is an adventure for use with the For Gold & Glory ruleset, a retroclone of 2nd edition of the world’s most popular roleplaying game. For Gold & Glory are trademarks of Justen Brown. This work is not affiliated with Justen Brown. This product is easy to convert for any of the old school rulesets of the OGL v1.0a.

