

in the second half of the twentieth century, the great powers compete for military supremacy on the world stage. a team of misfits—dreamers, fighters, and government lab rats who have fallen out of the bottom of society—are reborn as soldiers of fortune navigating a web of intrigue and conspiracy. perhaps your prime minister has been psychically attacked in his sleep. perhaps your top scientists have disastrously opened a gate to another dimension. perhaps your enemies are on the cusp of perfecting robotic superweapons, astral projection, or biological warfare. for the right price, those misfits can help.

when you're all out of options, it's time to call...

# FIST

## FREELANCE INFANTRY STRIKE TEAM

## CREDITS

**writing, design, and layout by**  
b. everett dutton

**design consulting by**  
dominik kirsten-parsch

**typefaces provided by**  
florian karsten typefaces (space grotesk), OSP-foundry (univers else), URW type foundry (microgramma)

**schematics provided by**  
john titor, uxoinfo, heroicrelics, and the numrich corporation

**tested by**  
brooke schnoor  
mike tarnowski

**inspired by**  
avery alder's "simple world"  
chris p. wolf's "offworlders"  
hideo kojima's "metal gear solid"  
john harper's "world of dungeons"  
stephen j. cannell and frank luppo's "the a-team"  
arnold drake, bob haney, and bruno premiani's "doom patrol"

**licensed under**  
CC BY 3.0 US (<https://creativecommons.org/licenses/by/3.0/us/legalcode>)

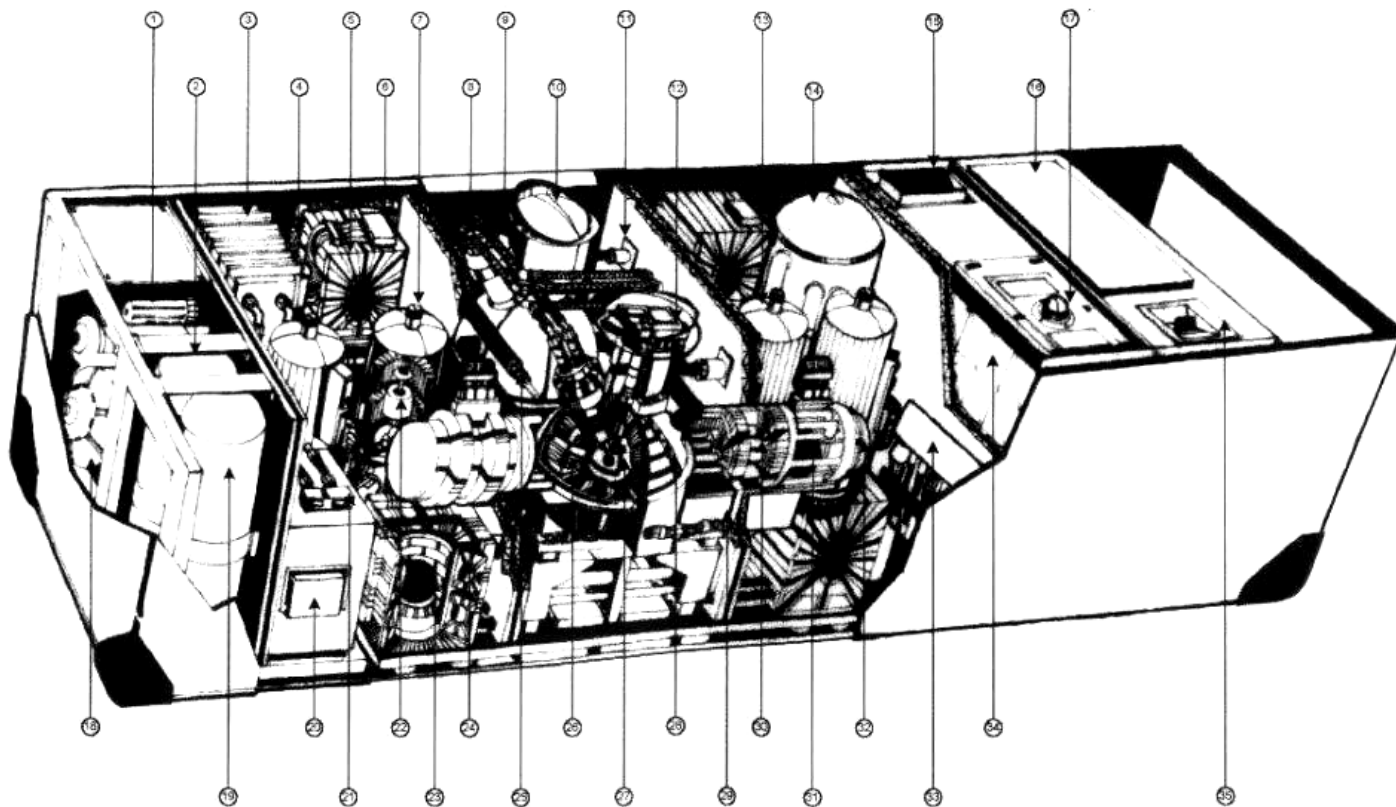

## PLAYERS

### getting started

necessary items for play and play as a conversation, p. 1

### making mercs

an explanation of traits and creating a character, p. 2

### rolling the dice

risky actions and rules of engagement, p. 5

### ongoing play

mission structure and character advancement, p. 6

## REFEREE

### referee guide

notes on referee operations, p. 7

### quality fiction

notes on the theater of the mind, p. 8

### custom content

quick reference guide for ludomechanical engineering, p. 9

## SUPPLIES

### character sheet

reusable information form for FIST operatives, p. 10

### traits index

list of known traits for FIST operatives, p. 13

### roles index

list of known motives for FIST operatives, p. 16

# GETTING STARTED

necessary items for play  
to play FIST, you'll need:

- this rulebook
- two to six other people
- at least two six-sided dice (also called "2D6")
- copies of the character sheet for each player, p. 10
- communal copies of the traits and roles indexes, p. 13-16
- paper and pencils

## play as a conversation

FIST functions like a conversation between the players and the referee. the referee narrates the story, environments, and characters the players are interacting with. the players respond by asking the referee for details, talking to characters they encounter, and narrating their own actions. when a player does something risky, the referee will tell them how to roll the dice to find out what happens next.

FIST doesn't have formal turns split up into a certain amount of actions. players will take turns talking amongst each other and to the referee, but mostly in the same way they would in a normal conversation. in FIST, it's okay to let things flow naturally—the game is meant to be fun, quick, and abstract. sometimes, you'll be in the spotlight describing something cool, complex, or confusing. other times, you'll step out of the spotlight to let other players do the same.

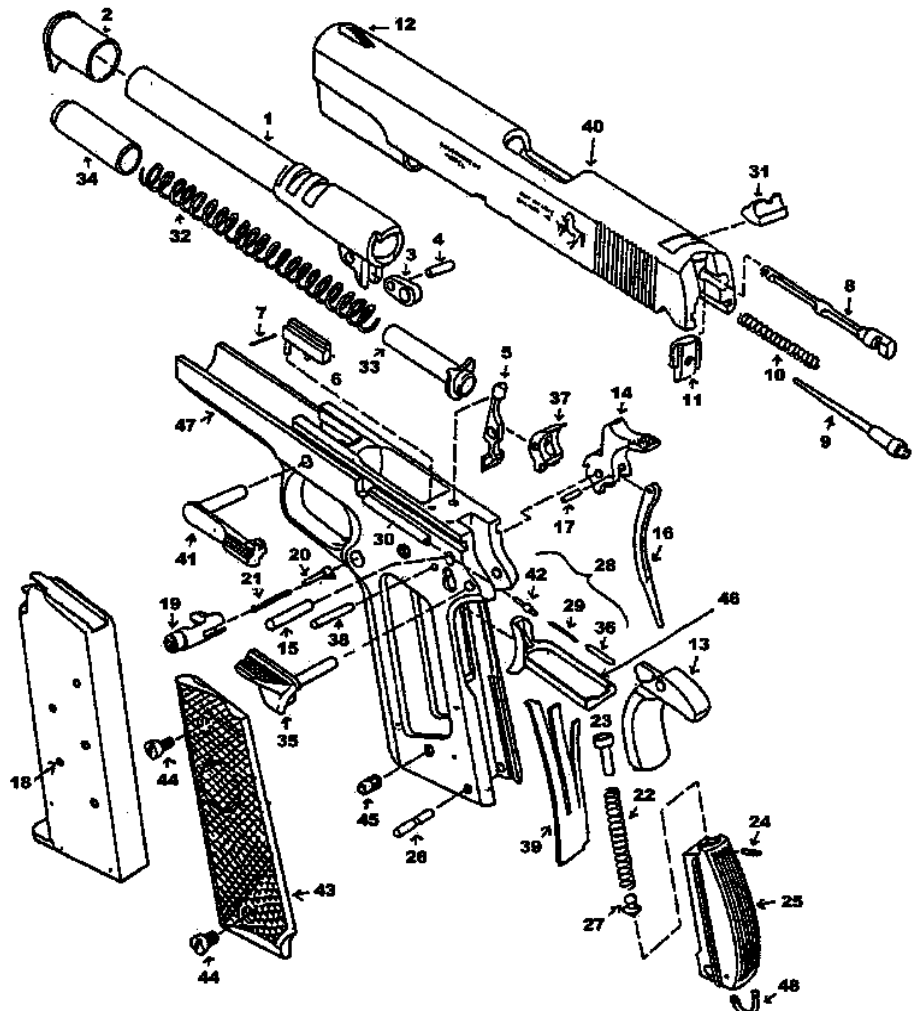

# MAKING MERCs

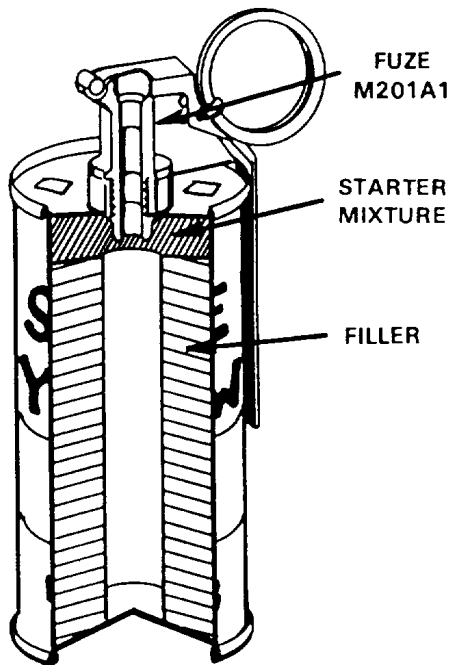

## an explanation of traits

traits are the building blocks of FIST characters. each trait grants you three things: a special skill or benefit, an item for your inventory (like a weapon or tool), and a modification to your stats (like your attributes or HP). picking a handful of traits generates a complete character. when a character advances, they gain another trait—it's like adding on another building block that makes them more complex or powerful.

## creating a character

you belong to a legendary rogue mercenary unit called FIST. you are a soldier of fortune who doesn't fit into modern society. you are one of the little guys, caught up in the death and destruction of pointless proxy wars and oppressive establishments. you may also be someone who can turn into a ghost or control bees with their mind. the paranormal secrets of the cold war are your bread and butter, and you fight for your life as you make ends meet alongside others like you.

### 1. procure a character sheet (p. 10).

prominently featured on the character sheet are your character's attributes: FORCEFUL, TACTICAL, CREATIVE, and REFLEXIVE. an attribute represents a character's skill level when approaching a related challenge. a higher number means a higher chance of success when using that attribute.

### 2. pick two traits from the traits index (p. 13).

record your chosen traits on your character sheet. keep the traits index on hand for reference.

### 3. fill out your ATTRIBUTES, INVENTORY, ARMOR, and HP.

all your attributes start at 0. calculate what they are after picking two traits, and write them all down.

all characters start with an optional Pistol (1D6 damage) in their inventory. fill the rest of your inventory with any items your traits gave you. you can always carry as many items as you want, but you can only equip one weapon at a time.

all characters start with 0 ARMOR. if one of the items in your inventory grants an ARMOR bonus, you can wear it and set that as your ARMOR instead of 0. if you get better armor later on, you can wear that instead, but you can only wear one thing at a time—ARMOR doesn't stack.

all characters have MAX HP equal to  $12 + \text{FORCEFUL} + \text{REFLEXIVE}$ . fill in your MAX HP. HP stands for "hit points", and represents how much you can get hurt before dying.

### 4. choose a role from the roles index (p. 16)

your role is something your character always wants to do. you can't choose a role someone else already has.

### 4. choose a codename.

pick a codename for yourself that fits who you are and what you do. also, pick a real name, but never tell anyone what it is—not even the referee—until you have the perfectly intimate and dramatic moment.



23 OCTOBER 1962

MEMORANDUM FOR : DIRECTOR [REDACTED]  
CENTRAL INTELLIGENCE AGENCY

FROM : AMBASSADOR [REDACTED]  
UNITED NATIONS

SUBJECT : "FIST" CUBAN INTERVENTION UNIT MEMBER DATA  
INTEL FILE NO. [REDACTED] - [REDACTED]  
CODENAME: "PREMADE EXAMPLE CHARACTERS"

**1. "HAMMURABI"**

FORCEFUL: 0      TACTICAL: 2  
CREATIVE: 0      REFLEXIVE: 0  
HP: 12/12      ARMOR: 1  
ROLE: ICON  
TRAITS: DISGUISE, TACTICIAN  
INVENTORY:  
PISTOL (1D6 DAMAGE),  
BULLETPROOF VEST (1 ARMOR),  
NIGHT VISION GOGGLES

There is an unsubstantiated rumor that "Hammurabi" was at one point a celebrated military commander in the service of the [REDACTED] government, and only went into mercenary work after being framed for someone else's crime. However, I have yet to find any service record matching his profile.

**2. "RED FOX"**

FORCEFUL: 0      TACTICAL: 0  
CREATIVE: 0      REFLEXIVE: 1  
HP: 13/13      ARMOR: 1  
ROLE: AVENGER  
TRAITS: CYBORG, DUELIST  
INVENTORY:  
EXOSKELETON (1 ARMOR),  
BEAM KATANA (1D6+1 DAMAGE)

"Red Fox" is a highly effective Kenyan swordfighter equipped with advanced Soviet bionics. Major General [REDACTED] of the British Army is responsible for the death of her family during the Mau Mau Uprising. Reports indicate that many of her seemingly arbitrary decisions are in fact part of a grand and intricate plan to enact vengeance.

15 MARCH 1953

MEMORANDUM FOR : MR. [REDACTED]  
DIRECTOR, FEDERAL BUREAU OF INVESTIGATION

FROM : LT. CMDR. [REDACTED]  
SECRETARY, DEPARTMENT OF DEFENSE

SUBJECT : DATA ON "FIST" SOLDIERS INVOLVED WITH LEAKING  
INTEL FILE NO. [REDACTED] - [REDACTED] ON PROECT RAINBOW  
CODENAME: "MORE PREMADE EXAMPLE CHARACTERS"

### 3. "DRUNKEN MONKEY"

FORCEFUL: 0      TACTICAL: 0  
CREATIVE: 0      REFLEXIVE: 1  
HP: 13/13      ARMOR: 0  
ROLE: WILDCARD  
TRAITS: KARATE, LUSH  
INVENTORY:  
HAND WRAPS (1D6+1 DAMAGE),  
LIQUOR BOTTLE (1 USE PER SESSION)

[REDACTED] is a Japanese martial arts master who gained widespread notoriety, and the nickname "Drunken Monkey", after several altercations with police while wandering China. He is far more dangerous when intoxicated.

### 4. "DOCTOR GHOST"

FORCEFUL: 0      TACTICAL: 0  
CREATIVE: 0      REFLEXIVE: 1  
HP: 14/14      ARMOR: 1  
ROLE: CRUSADER  
TRAITS: MEDIC, PROJECTION  
INVENTORY:  
FIRST AID KIT (3 USES PER SESSION),  
FLOWING GARMENT (1 ARMOR)

Doctor [REDACTED] was stationed at a MASH unit in Korea until receiving a Section 8 discharge and returning home. The Doctor (gender unclear) seems to have developed an intense interest in the occult writings of Aleister Crowley and apparently was involved in an intimate relationship with Mr. Jack Parsons before his death. Stay alert: "Doctor Ghost" does not engage in combat, but can become a non-corporeal spirit entity at will.

# ROLLING THE DICE

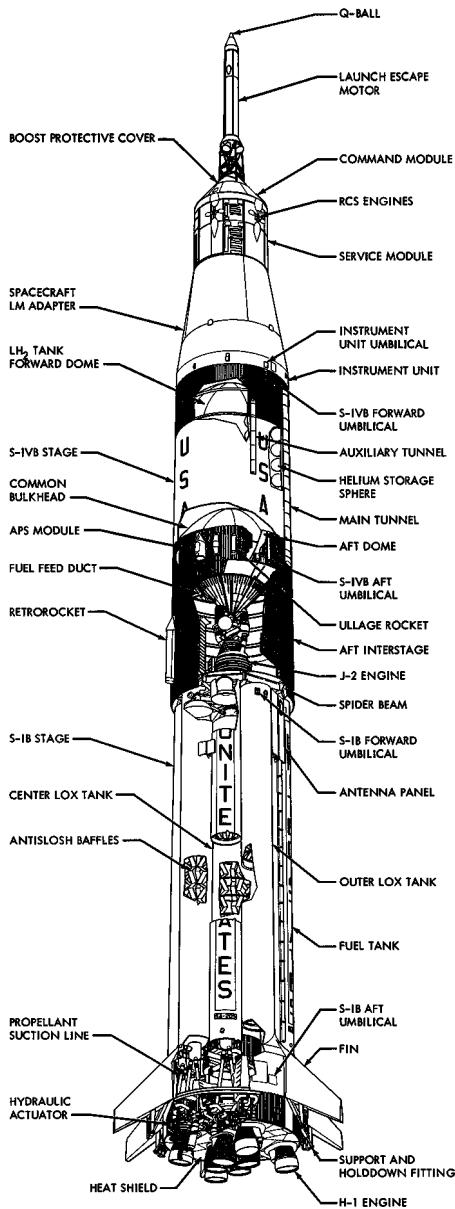

## risky actions

when you do something risky—that is, any action where the outcome is uncertain—you roll the dice to find out what happens. you don't need to roll the dice when it's something the character could easily accomplish, and you shouldn't roll the dice when it's something completely impossible.

### 1. choose an attribute.

the referee will ask you which of your attributes you're using, or they might decide for you if the answer is unclear. the referee will also tell you some of the possible outcomes of your action, so you know what you're up against.

ROLL +FORCEFUL for displays of strength, like kicking in doors, using clunky, powerful weapons, or intimidating others.

ROLL +TACTICAL for intellectual actions, like maintaining a disguise, hacking into a database, or operating machinery.

ROLL +CREATIVE for expressions of will, like persuasive speeches, off-the-cuff bluffing, or psychic manipulation.

ROLL +REFLEXIVE for dexterous movements, like dodging bullets, using precise weapons, or parrying enemy attacks.

### 2. roll the dice.

roll 2D6, add them together, and add the attribute you're using. the total determines your degree of success. no matter what happens, the referee always narrates how fictional situation changes. it never stays the same.

6 OR BELOW: your roll is a failure. you don't do what you wanted to do, and things go wrong somehow.

7 TO 9: your roll is a partial success. you do what you wanted to, but with a cost, compromise, or complication.

10 OR ABOVE: your roll is a success. you do exactly what you wanted to do, without any additional headaches.

DOUBLE SIXES: your roll is a critical success! you do exactly what you wanted to do, with a spectacular added bonus.

the referee never has to roll the dice, only the players do. the referee narrates things that are about to happen and the players roll to avoid or counter them.

## rules of engagement

attacking works the same as doing anything else risky. roll the dice to see if you succeed, and if you do, deal the damage listed for your weapon. if you're being attacked, roll the dice to avoid, counter, etc., and take damage if you fail.

if you take damage, subtract it from your HP. if you take damage while wearing armor, subtract the ARMOR bonus from the damage dealt. if your HP drops to 0, you're dead.

there are no saving throws in war, my friend.

# ONGOING PLAY

## mission structure

FIST campaigns are framed as a series of missions. sometimes, the missions fall into an overarching plot or grand conspiracy. other times, they're just one-off jobs. periodically, the mission might be unpaid and done for a personal reason, like squaring off with an old nemesis or doing something you should have done a long time ago.

player characters start each mission at full health with all limited-use items fully refilled and gear already equipped.

there is no currency system in FIST, so paid jobs are just a framing device—don't restrict what kinds of missions you're willing to take based on what pays well and what doesn't.

## character advancement

characters advance when they act according to their role. for instance, a CRUSADER advances if they behaved ethically during the course of a mission.

if a character advances, they can choose another trait at the beginning of the next session and narrate how they gained that trait to add some personal flavor. for instance, a player who chose the ILLUSION trait could explain that they used a sensory deprivation tank to activate latent psychic abilities, or that they constructed a swarm of holographic projection drones to do their bidding.

remember to re-calculate your ATTRIBUTES and MAX HP when you advance.

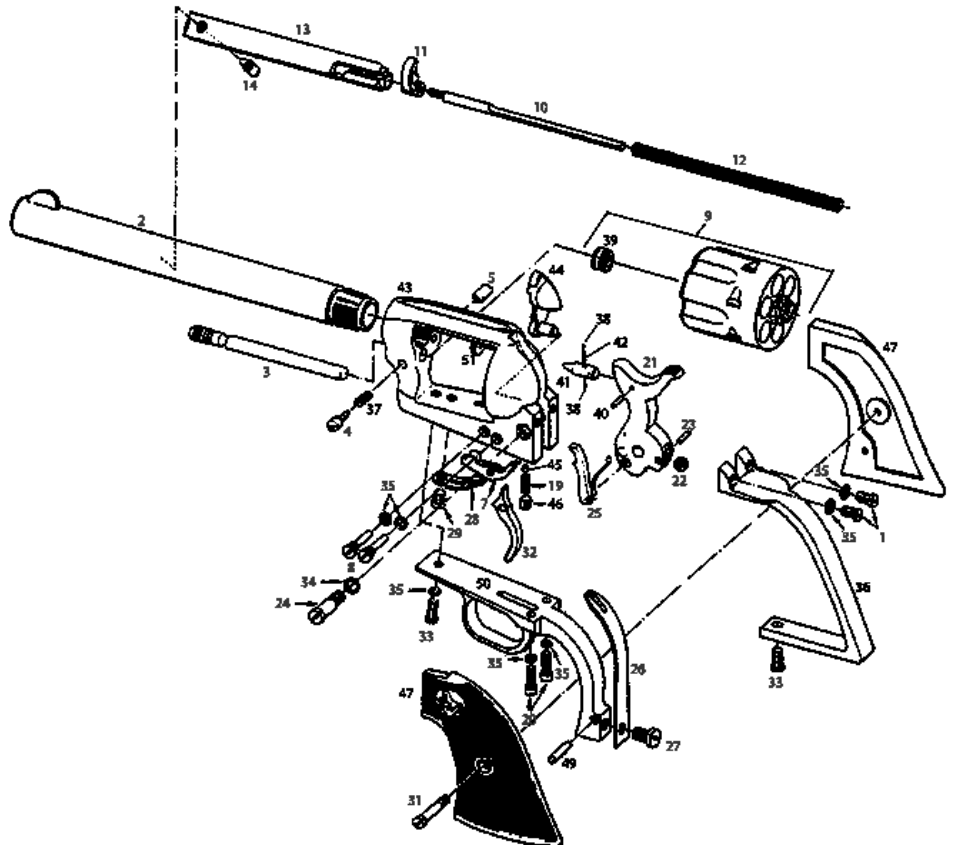

# REFEREE GUIDE

## notes on referee operations

instead of playing a mercenary, you fill in the story, environments, and characters the unit will interact with. FIST functions like a conversation between the players and the referee. you narrate the situation, a player responds with their reaction and possibly rolls the dice, and you respond in turn with how the scenario has meaningfully changed in a way that follows logically from the fiction. you have three goals to keep in mind while you have this conversation.

### 1. supply cold war intrigue and paranormal excitement.

the soviet union is harnessing a portal to another dimension to gain the edge against the west. a pharmaceutical corporation is breeding a mind-controlling fungus to sell to the central intelligence agency as a biological weapon. a rogue cell of mercenaries is developing a massive robotic superweapon to pawn off to the highest bidder. excite your players with grand conspiracies and strange phenomena beyond the fringes of scientific thought.

### 2. never stop the action.

always keep things moving, and never stop pushing the players forward. challenge them, and always keep the mission one wrong move away from failure. be a fan of their characters, and create opportunities for them to be to cool. above all, follow the rule of fun before the rules as written.

### 3. play to find out what happens.

outline the events you want the players to experience, and the people you want them to engage with. note oncoming dangers and their consequences if left unchecked. then, look at all your ideas through crosshairs, and be ready to improvise based how the dice and players steer the story.

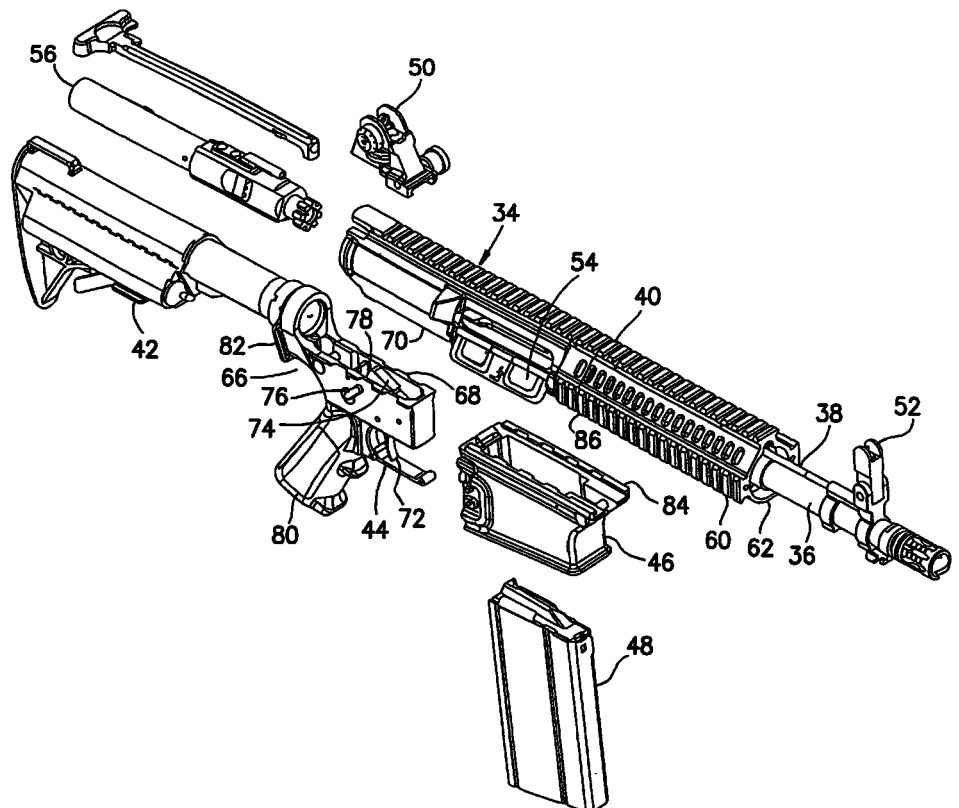

# QUALITY FICTION

## notes on the theater of the mind

FIST games are about telling an engaging story, not creating an accurate simulation of a fictional situation. there are several ideas to keep in mind while using FIST to tell a story,

### 1. respond to the dice.

rolling the dice is the key mechanism to propel the story. when a player rolls a failure, it doesn't just mean they didn't get what they wanted—it's the referee's opportunity to inflict a negative consequence that still changes the situation, letting the characters "fail forward". when a player rolls a success, a new challenge should appear that follows logically from how their actions changed the situation. most of the time, the players will roll partial successes, so you should always be thinking of downsides to good plans, bittersweet victories, and difficult compromises.

### 2. plan around the characters.

a lot of the game mechanics require specific fictional situations to function correctly, and you should design your missions to be conducive to those mechanics. if you have a TELEKINETIC character who controls water, you probably shouldn't set your missions in a desert, unless doing so would make things more interesting and engage that character more. if you have a character who fills the PUNK role, you should provide them with establishments to dismantle and oppressed peoples to fight for. challenge your players, but give them ample opportunities to shine.

### 3. ask questions and use the answers.

FIST explicitly states that it is set during the cold war, the characters are part of a legendary group of mercenaries, and the paranormal is both real and immediately relevant. everything else is left up to interpretation. engage your players in the world by letting them flesh out the setting alongside you.

in the process of character creation, some things about the world may be defined naturally—someone whose character fills the role of AVENGER will define who wronged them, giving you a character to use as a recurring on- or offscreen villain. someone who has the XENO trait will probably elaborate on their alien species, giving you an interesting new faction to insert as a third party in certain missions. continuously ask your players questions about the world that their characters would reasonably know the answers to, and use those answers when planning the specifics of your next mission.

### 4. adjudicate trait abilities fairly.

some traits in the game are vaguely defined or leave a lot of room to make a game breaking, too-powerful character. let your players do cool things—if a character with the AKIMBO trait wants to dual wield a sword and a rocket launcher, let them, because that's cool—but keep things fair for the other players, too. conversely, don't cheat the players out of being cool or powerful. let them be legendary mercenaries. if the function or scope of a trait is unclear, you have the final say, but never be afraid to open a dialogue at the table. there is no downside to a fun "what-if" conversation.

# CUSTOM CONTENT

## quick reference guide for ludomechanical engineering

FIST includes a premade mission (p. 12), but you can use this reference guide to create your own content.

### 1. creating enemies.

for more specific designs, try tweaking these templates based on the armor and weapons listed in the traits index.

civilians, animals (2 HP, 0 ARMOR, 1D6 damage)  
soldiers, security guards (3 HP, 1 ARMOR, 1D6 damage)  
heavy troopers, gov. agents (6 HP, 1 ARMOR, 1D6+1 damage)  
strong paranormal entities (8 HP, 2 ARMOR, 1D6+2 damage)  
enormous monstrosities (12 HP, 3 ARMOR, 2D6 damage)

### 2. creating weapons

useful if the characters lose their personal weapons and must procure weapons on-site.

light weapons (pistols, knives). 1D6 damage. concealable.  
medium weapons (rifles, shotguns, swords). 1D6+1 damage.  
heavy weapons (RPGs, gatling guns). 1D6+2 damage.

here are some modifications to add to weapons found on-site, or to a personal weapon as an advancement reward.

armor-piercing rounds: ignores ARMOR bonus completely.  
incendiary rounds: deals an extra 2 damage to those nearby.

tranquilizing rounds: knocks enemy unconscious at 0 HP.

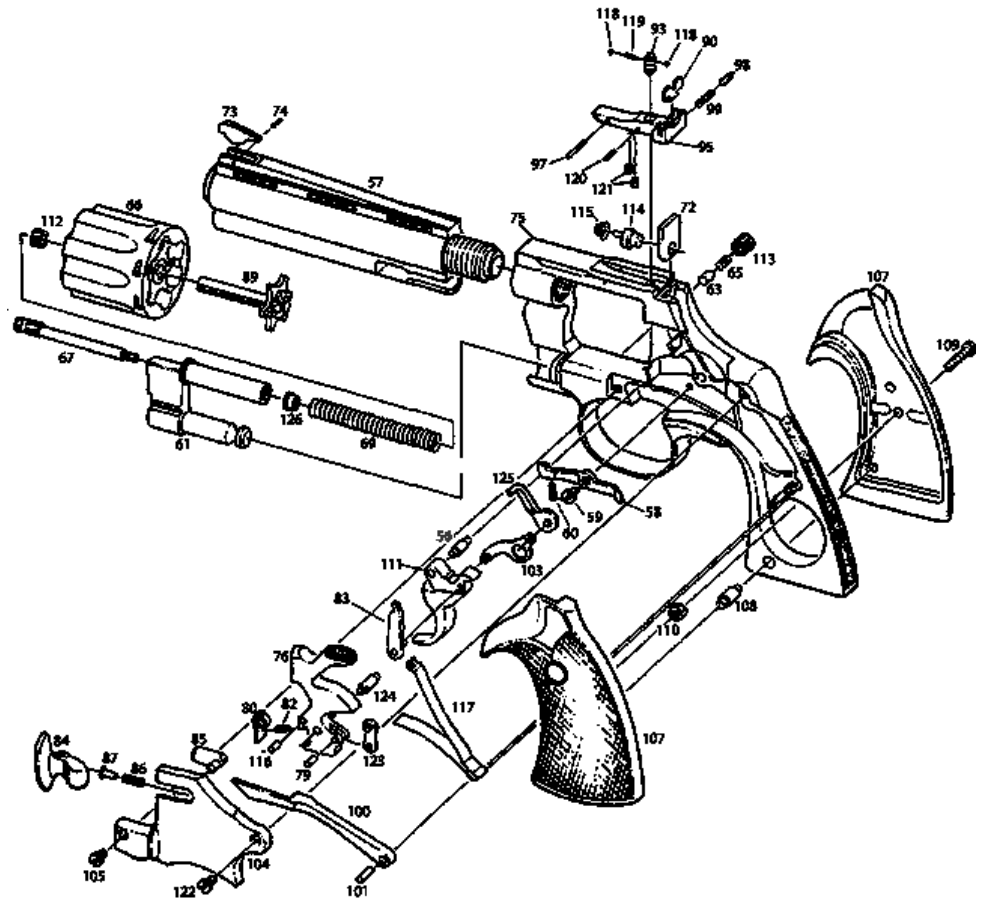

TO: DIRECTOR [REDACTED]  
CYCLOPS INTELLIGENCE DIVISION  
GLOBAL SHADOW GOVERNMENT

FROM: [REDACTED]  
CYCLOPS RESEARCH OPERATIONS

SUBJECT: FIST MEMBER DATA  
CODENAME: "CHARACTER SHEET"

1. CODENAME:

2. ATTRIBUTES:

FORCEFUL:	TACTICAL:
CREATIVE:	REFLEXIVE:

3. ROLE:

4. TRAITS:

5. INVENTORY:



21 MAY 1983

TO: DIRECTOR [REDACTED]  
CENTRAL INTELLIGENCE AGENCY  
UNITED STATES OF AMERICA

FROM: DIRECTOR [REDACTED]  
CYCLOPS INTELLIGENCE DIVISION  
GLOBAL SHADOW GOVERNMENT

SUBJECT: NEW FIST RECRUITS, INTEL FILE NO. [REDACTED] - [REDACTED]  
CODENAME: "CHARACTERS FOR EXAMPLE MISSION"

1. "HALBERD"

FORCEFUL: 1      TACTICAL: -2  
CREATIVE: 0      REFLEXIVE: -2  
HP: 11/11      ARMOR: 3  
ROLE: REPENTANT  
TRAITS: ARMORED, BERSERKER, HEAVYWEIGHT,  
VETERAN  
INVENTORY:  
POWER ARMOR (2 ARMOR)  
GATLING GUN (1D6+2 DAMAGE)  
SHOTGUN (1D6+1 DAMAGE)

"Halberd" is a Vietnam War veteran who was discharged after [REDACTED] permanently fused him with his experimental armor. He is a nearly unstoppable force and is unstable after a traumatic experience with killing POWs.

2. "GRAY MAULER"

FORCEFUL: 1      TACTICAL: 0  
CREATIVE: 1      REFLEXIVE: 1  
HP: 14/14      ARMOR: 1  
ROLE: SCHOLAR  
TRAITS: INTERROGATION, SNEAK, XENO  
INVENTORY:  
KNIFE (1D6 DAMAGE)  
CAMOFLUAGE FATIGUES (1 ARMOR)  
LASER PISTOL (1D6+1 DAMAGE)

We suspect "Gray Mauler" is a survivor of the crash which occurred in [REDACTED] New Mexico, thirty years ago. They seem preoccupied with learning political secrets. They are extremely difficult to maintain a visual on; remain alert.

16 AUGUST 1983

TO : ██████████  
FIST COMMANDING OFFICER

FROM : ██████████

SUBJECT : ██████████ MISSION OUTLINE  
CODENAME: "EXAMPLE MISSION"

### 1. TACTICS

A Burkinabé contact has hired FIST to investigate an abandoned factory on the Ghanaian border which he believes is being occupied and operated by French Colonial stragglers. Eyewitness reports tell of a strange, sweet odor in the surrounding area and several missing civilians. FIST is tasked with investigating and, if necessary, neutralizing the French Colonial forces.

The players begin outside the factory, which is surrounded by savannah that offers little cover. Nightfall is several hours away. The factory has several viable entrances being guarded by SOLDIERS (3 HP, 1 ARMOR, 1D6 DAMAGE), the most heavily protected of which is the loading bay. Infiltration is a fitting task for Gray Mauler, who can use SNEAK to infiltrate and then find a way in for Halberd.

### 2. ESPIONAGE

Once inside, the players find a makeshift laboratory where English-speaking scientists are discussing the artificial flesh eating parasite with which they will infect and weaken the Burkinabé populace, allowing France to begin a full-out recolonization effort. During an INTERROGATION, they will reveal they work for CYCLOPS, the intelligence division of the global shadow government (fulfilling the SCHOLAR role for Gray). The players can also find a makeshift holding cell and free prospective test subjects by using HEAVYWEIGHT (fulfilling the REPENTANT role for Halberd). They can also find the loading bay, which is filled with trucks containing stable parasite samples. The factory halls are periodically patrolled by HEAVY TROOPERS (3 HP, 2 ARMOR, 1D6+1 DAMAGE).

### 3. ACTION

When the players complete their investigation of the factory, they will hear sudden screaming in the loading bay. If they go there, they will find that the French soldiers have disturbed the stable parasite samples and been fused into a WRITHING MASS OF FLESH (16 HP, 3 ARMOR, 2D6 DAMAGE). If the players do not choose to investigate the screaming or choose to evacuate the loading bay, the monster will barrel down the hallways after them in an attempt to absorb them. The monster will be easier to fight due to Halberd's ARMORED, BERSERKER, and VETERAN traits. The players may also observe that the monster has no interest in absorbing Gray Mauler due to their XENO trait. The mission is complete when the players have destroyed, neutralized, or imprisoned the monster.

# TRAITS INDEX

**AKIMBO:** you can wield any two weapons at once, but your accuracy is decreased. when you deal damage, roll 2D6 using the more powerful weapon and take the higher die.  
- submachine gun x2 (1D6 damage), -1 to attacking

**ARMORED:** you are fused with a cumbersome suit of powered armor that you cannot remove. once per session, you can completely ignore damage dealt to you.  
- power armor (2 ARMOR), -2 REFLEXIVE

**BERSERKER:** if you rush into combat with no precaution or pre-planning, your first attack will deal double damage.  
- gatling gun (1D6+2 damage), -2 TACTICAL

**CHARM:** you can always manipulate anyone else into doing what you want, but you will have to make a sacrifice or maintain a difficult lie—the referee will tell you how.  
- combat tuxedo (1 ARMOR), +1 CREATIVE

**COMMANDO:** you take +1 to damage rolls during a fight with an extremely large opponent, but -2 to damage when you aren't fighting alone.  
- rocket launcher (1D6+2 damage), +1 FORCEFUL

**CYBORG:** you have augmented superhuman agility. you can reroll one damage die—dealing or receiving—once per fight.  
- exoskeleton (1 ARMOR), +1 REFLEXIVE

**DISGUISE:** you can disguise yourself as anyone as long as you have a reasonable amount of prep time; however, your cover will be blown if you either speak, move quickly, or get hurt—the referee will tell you which.  
- bulletproof vest (1 ARMOR), +1 TACTICAL

**DRUID:** you thrive in nature and wither in combat, drained by the bloodshed and metal. you can understand the thoughts of animals, and ask them to tell you things or do things for you—though they will not always comply.  
- medicinal herb (+1D6 HP, one use), -2 MAX HP

**DUELIST:** you take +1 to damage rolls during a fair fight with a single opponent. you take another +1 to damage rolls if you attempt to intimidate, taunt, or seduce that opponent.  
- beam katana (1D6+1 damage), +2 melee damage

**FIEND:** you utilize amphetamines to enhance your focus. when you have a second free, you can pop some pills and take +2 to your next TACTICAL roll.  
- pill bottle (one use), -2 MAX HP

**HACKER:** if you have a reasonable amount of prep time, you can attempt to gain control of any computer or electronic machine by rolling the dice +TACTICAL.  
- energy drink (+1D6 HP, one use), +1 TACTICAL

**HEAVYWEIGHT:** you can tear through most inanimate obstacles with ease. if it's something really tough, like solid concrete or metal, it will be more difficult and complicated—the referee will explain how.  
- shotgun (1D6+1 damage), +1 FORCEFUL

# TRAITS INDEX

**HYPNOSIS:** you are in a permanent state of self-hypnosis which maximizes your efficiency in combat but suppresses your sense of self. any time you roll the dice, you can reroll one die. you cannot speak.

- nutrient slurry (+2D6 HP, one use), -2 CREATIVE

**ILLUSION:** you can attempt to manipulate another person into hallucinating anything of your choice by rolling +CREATIVE. rolling higher creates a more believable illusion.

- whip (1D6 damage), +1 CREATIVE

**IMPROVISE:** you can improvise a weapon from common objects to instantly kill a single enemy once per session.

- garotte wire (1D6 damage), +1 CREATIVE

**INTERROGATION:** you can lock an unsuspecting enemy in a chokehold and ask them one question, which they will always answer truthfully before trying to escape.

- knife (1D6 damage), +1 FORCEFUL

**KARATE:** you can silently knock any enemy unconscious, but they might make noise or wake up at an inconvenient time—the referee will tell you the downside.

- hand wraps (1D6 damage), +1 REFLEXIVE

**LUSH:** you prefer to fight at least half in the bag. when you have some free time, you can down a few shots and take +2 to your next FORCEFUL roll.

- liquor bottle (one use), -2 MAX HP

**MEDIC:** with prep time, you can heal anyone for 1D6 HP.

- first aid kit (three uses per session), +1 MAX HP

**MUTANT:** you are mutated and sickly. at the beginning of each session, you must drop one skill you already have and take a new one instead, recalculating your attributes and HP.

- gas grenade (1D6+2 damage, one use), -2 FORCEFUL

**PUPPETMASTER:** you can implant a command in someone's brain by rolling the dice +FORCEFUL. if you succeed, they have no choice but to follow it.

- strappy leather harness (1 ARMOR), +1 FORCEFUL

**PROJECTION:** you can project your spirit from your body to view any faraway place remotely, as long as your physical body is somewhere completely safe. you can also cheat death once per session by abandoning your body, but you will be stuck in spirit form until it gets medical attention.

- flowing garment (1 ARMOR), +1 REFLEXIVE

**PYROMANIAC:** you are burned all over from repeated exposure to fire. if there is something flammable nearby, you can always ignite it.

- molotov (1D6+2 damage, one use), -2 MAX HP

**SHARPSHOOTER:** if you name a specific body part, possession, or component of something you're attacking with a ranged weapon, you will always hit, disabling that part rather than dealing damage.

- revolver (1D6+1 damage), +1 REFLEXIVE

# TRAITS INDEX

**SNEAK:** if you hold still in a good hiding spot, no one will see you until you make your presence known. you can also easily fit into small containers like barrels and carboard boxes.  
- camouflage fatigues (1 ARMOR), +1 REFLEXIVE

**SMOKER:** you are addicted to nicotine. when you have some downtime, you can calm your nerves with a cigarette and take +2 to your next REFLEXIVE roll.  
- cigarette case (one use), -2 MAX HP

**SNATCHER:** you are an alien poorly puppeteering a technically dead human body. you kill with a touch. if you do not consume one human brain without anyone finding out once per session, you will melt into a puddle and die.  
- life-draining fingertips (2D6 damage), -2 MAX HP

**SNIPER:** if you have prep time, the enemy is unaware of your presence, and you remain stationary, you can roll 3D6 to attack and use the best two dice. if you succeed, you deal the maximum damage for your weapon.  
- sniper rifle (1D6+1 damage), +2 ranged damage

**SUPPLY:** you know secret frequencies and can use your radio to get any item delivered in a pinch. however, there will be a catch, like an inconvenient pickup spot or a fault with the item—the referee will tell you what.  
- radio (three uses), +1 TACTICAL

**SYNTHETIC:** you are human-like android. your positronic brain can make thousands of calculations per second. you take 1D6 damage when exposed to water.  
- experimental railgun (1D6+2 damage), +1 TACTICAL

**TACTICIAN:** if you explain an elaborate plan of action to the unit, all partial success rolls count as total success rolls while the plan is being executed—until someone rolls a failure, at which point the plan falls apart catastrophically.  
- night vision goggles (can see at night), +1 TACTICAL

**TELEKINETIC:** you have telekinetic control over any one substance of your choice - it could be something simple like water or metal, or something more esoteric like blood or flies. you have a unique accessory, such as a mask or a pendant, which you channel your power through. if this psychic amplifier is damaged or lost, you are no longer telekinetic until you repair or replace it.  
- psychic amplifier, +1 CREATIVE

**TRIPPER:** you are a hallucinogen enthusiast. when you have some time to relax, you can drop a tab to expand your consciousness and take +2 to your next CREATIVE roll.  
- acid tab (one use), -2 MAX HP

**VETERAN:** whenever you enter a new area, you can ask the referee if there is hidden danger, and get an honest answer.  
- assault rifle (1D6+1 damage), +1 ARMOR at all times

**XENO:** you do not look, think, or act like a human. you are clearly an alien, and cannot blend into groups of humans.  
- laser pistol (1D6+1 damage), +1 CREATIVE

# ROLES INDEX

## **AVENGER**

describe someone who wronged you, and what they did.

advance if something you did during this session brought you closer to exacting your revenge, or defeated someone who is wronging others in the same way.

## **CHESSMASTER**

describe what you plan to do with absolute power.

advance if something you did brought you closer to holding a position of extreme power over a large group of people.

## **CRUSADER**

describe an ethical ideal you hold dear that is difficult to achieve.

advance if something you did during this session aligned with that ethical ideal, even though it made your life harder.

## **GLADIATOR**

describe a warrior you admire and aspire to emulate.

advance if you fought and bested a powerful enemy using only the most honorable of tactics during this session.

## **ICON**

describe how you want to go down in history.

advance if something you did during this session brought you closer to becoming a world-famous legend, or ensured a group of people would never forget your name.

## **PUNK**

describe an oppressive establishment that hurt you

advance if something you did during this session helped brutally and decisively smash that establishment, or meaningfully helped people who are also being oppressed by that establishment.

## **REPENTANT**

describe a shameful and horrible decision from your past.

advance if something you did during this session made up for your sins in a major, meaningful way.

## **SCHOLAR**

describe the esoteric and obscure subject you are most curious about.

advance if something you did during this session brought you closer to unlocking the secrets of that subject.

## **WILDCARD**

describe your primary vice or source of pleasure, such as money, romance, or pain.

advance if you got your fix during this session in a way nobody, including yourself, expected.

**END TRANSMISSION**