

**KEO3-08**

# **A Little War: Prelude**

## **A One-Round D&D LIVING GREYHAWK<sup>®</sup> Keoland Regional Adventure**

Version 1.0

**by Kevin Lawson**

Forces are mustering in the shadows of the Jotens under the command of a mysterious Suel mage. Towns in the county of Cryllor have been threatened; the village of Kilm has been razed. Now, savages raid the farmlands of the Good Hills Union. Questions must be answered. Who is this mysterious leader? What is the source of the raiders? And just how much is Pemlo's stock actually worth? An adventure for APL 2 – 12. This module is the second in the *Good Hills Gone Bad* series that began with KEO2-08 *Pemlo's Lambic*.

Based on the original DUNGEONS & DRAGONS<sup>®</sup> rules created by E. Gary Gygax and Dave Arneson and the new DUNGEONS & DRAGONS game designed by Jonathan Tweet, Monte Cook, Skip Williams, Richard Baker, and Peter Adkison.

This game product contains no Open Game Content. No portion of this work may be reproduced in any form without permission of the author. To learn more about the Open Gaming License and the d20 system license, please visit [www.wizards.com/d20](http://www.wizards.com/d20)

DUNGEONS & DRAGONS, D&D, GREYHAWK and RPGA are registered trademarks of Wizards of the Coast, Inc. LIVING GREYHAWK is a trademark of Wizards of the Coast, Inc. ALL RIGHTS RESERVED. This scenario is intended for tournament use only and may not be reproduced without approval of the RPGA Network.

## Introduction

---

This is an RPGA® Network scenario for the Dungeons & Dragons® game. A four-hour time block has been allocated for each round of this scenario, but the actual playing time will be closer to three and a half hours. The rest of the time is spent in preparation before game play, and scoring after the game. The following guidelines are here to help you with both the preparation and voting segment of the game. Read this page carefully so that you know and can communicate to your players the special aspects of playing an RPGA scenario.

## Preparation

---

First you should print this scenario. This scenario was created to support double-sided printing, but printing it single sided will work as well. There is enough room along the inside margin to bind the adventure, if you desire.

Read this entire adventure at least once before you run your game. Be sure to familiarize yourself with any special rules, spells, or equipment presented in the adventure. It may help to highlight particularly important passages.

When you run an RPGA D&D adventure we assume that you have access to the following books: the *Player's Handbook*, the *Dungeon Master's Guide*, and the *Monster Manual*. We also assume that you have a set of dice (at least one d4, d6, d8, d10, d12, and d20), some scrap paper, a pencil, an RPGA scoring packet, and your sense of fun. It is also a good idea to have a way to track movement during combat. This can be as simple as a pad of graph paper and a pencil, as handy as a vinyl grid map and chits, or as elaborate as resin dungeon walls and miniatures.

Instruct the players either to prepare their characters now, or wait until you read the introduction, depending on the requirements of the scenario as described in the introduction.

Keep in mind that you must have at least three players (not counting the DM), for the game session to be a sanctioned RPGA event. As well, you cannot have more than six players participating in the game.

Once you are ready to play, it is handy to instruct each player to place a nametag in front of him or her. The tag should have the player's name at the bottom, and the character's name, race, and gender at the top. This makes it easier for the players (and the DM) to keep track of who is playing which character.

The players are free to use the game rules to learn about equipment and weapons their characters are carrying. That said, you as the DM can bar the use of even core rulebooks during certain times of play. For example, the players are not free to consult the *Dungeon Master's Guide* when confronted with a trap or hazard, or the *Monster Manual* when confronted with a monster.

Some of the text in this scenario is written so that you may present it as written to the players, while other text is for your eyes only. Text for the players will be in gray boxes. It's strongly recommended that you paraphrase the player text instead of reading it aloud. Some of this text is general and must be adapted to the specific situation or to actions of the player characters.

## Scoring

---

After the players have completed the scenario or the time allotted to run the scenario has run out, the players and DM score the game. The RPGA has three ways to score its games. Consult your convention coordinator to determine which method to use for this scenario:

1. No-vote scoring: The players write their names and RPGA numbers on the scoring packet grid. You fill in the top of the grid. That is all. No one is rated. This method is used for people who are just playing for fun.
2. Partial scoring: The players rate the game master and the scenario on their player voting sheet, and provide personal information, but don't vote for other players. The game master rates the scenario and completes personal and event information, but does not rate the players as a team or vote for players. This method is used when there is no competition, but the event coordinator wants information on how the game masters are performing, or the game master wants feedback on his or her own performance.
3. Voting: Players and game masters complete the entire packet, including voting for best player. If this method is used, be sure to allow about 15-20 minutes for the players to briefly describe their characters to the other players, and about 5-10 minutes for voting. This method is used when the players want to know who played the "best" amongst the group, or when the adventure is run in tournament format with winners and prizes.

When using voting, rank the players in order of your voting choice while they are completing their forms, so that you are not influenced by their comments on your abilities. It's a good idea to have the players vote while

you determine treasure and experience awards for the scenario.

After voting, give the Scoring Packet to your event coordinator.

This is a LIVING GREYHAWK Adventure. As a LIVING adventure it is expected that players bring their own characters with them. If players do not have a LIVING GREYHAWK character generated, get a copy of the current LIVING GREYHAWK character generation guidelines, and a character sheet from your convention coordinator or the RPGA Web site, and then have any players without a character create one. Once all players have a LIVING GREYHAWK character, play can begin.

Along with the other materials that you are assumed to have in order to run a D&D game, it is also recommended that you have a copy of the LIVING GREYHAWK *Gazetteer*.

### Living Greyhawk Levels of Play

Because players bring their own characters to LIVING GREYHAWK games, this adventure's challenges are proportioned to the average character level of the PCs participating in the adventure. To determine the Average Party Level (APL):

1. Determine the character level for each of the PCs participating in the adventure.
2. If PCs bring animals that have been trained for combat (most likely being war horses, dogs trained for war), other than those brought by virtue of a class ability (i.e. animal companions, familiars, paladin's mounts, etc) use the sidebar chart to determine the number of levels you add to the sum above. Add each character's animals separately. A single PC may only bring four or fewer animals of this type, and animals with different CRs are added separately.
3. Sum the results of 1 and 2, and divide by the number of characters playing in the adventure. Round to the nearest whole number.
4. If you are running a table of six PCs, add one to that average.

By following these four steps, you will have determined the APL. Throughout this adventure, APLs categorize the level of challenge the PCs will face. APLs are given in even-numbered increments. If the APL of your group falls on an odd number, ask them before the adventure begins whether they would like to play a harder or easier adventure. Based on their choice, use either the higher or the lower adjacent APL.

APL also affects the amount of experience you may gain at the end of the adventure. If your character is three character levels or more either higher or lower than the APL this adventure is being played at, that character will receive only half of the experience points awarded for the adventure. This simulates the face that either your character was not as challenged as normal, or relied on help by higher-level characters to reach the objectives.

	Mundane Animals Effect on APL	# of Animals			
		1	2	3	4
CR of Animal	1/4 & 1/6	0	0	0	1
	1/3 & 1/2	0	0	1	1
	1	1	1	2	3
	2	2	3	4	5
	3	3	4	5	6
	4	4	6	7	8
	5	5	7	8	9
6	6	8	9	10	
7	7	9	10	11	

Note: LIVING GREYHAWK adventures are designed for APL 2 and higher. Three or four, or sometimes even five 1<sup>st</sup>-level characters may find difficulty with the challenges in a LIVING GREYHAWK adventure. If your group is APL 1 there are three things that you can do to help even the score.

1. Attempt to create a table of six 1<sup>st</sup>-level characters, or try to enlist higher-level characters to play at that table.
2. Advise characters to buy riding dogs to help protect them, and fight for them. All riding dogs are considered trained to attack. PCs who want their dogs to attack must succeed at a Handle Animal or Charisma check (DC 10). Failure indicates that the animal will not attack that round. This is a free action (spoken command) that may be attempted each round. If an animal loses half or more hp in a single round it flees, unless another check is successful.

### Time Units and Upkeep

This is a standard one-round Regional adventure, set in Keoland. Characters native to Keoland pay one Time Unit per round, all others pay two Time Units per round. Adventurer's Standard Upkeep costs 12gp per Time Unit. Rich Upkeep costs 50gp per Time Unit. Luxury Upkeep costs 100gp per Time Unit.

## Adventure Background

---

Since the conclusion of the Greyhawk Wars, marauders from the Jotens have beset the Western counties of Keoland. Savage tribes of orcs have extended their range, plaguing mining and farming communities in Cryllor, Flen and the Good Hills. Military reconnaissance has brought word that giants and giant kin have led certain well-organized war bands.

In CY589, one such war band razed the halfling village of Kilm. In response, Countess Allita Elgarin of Flen charged her son, the Lord Elgarin, with the task of discovering the source of the raiders. Lord Elgarin and his men never returned and the raiders' base has not been discovered.

In CY591, bands of orcs beset caravans on the western trade routes of Cryllor. With the aid of a group of adventurers and the Crylloran military, the stronghold of the orcs was discovered and its power broken (as described in KEO 1-02 *A Little Reconnaissance*). This victory was not enough to stem the tide of savages. Conflict continues to rage in the foothills of the Jotens, and the Lady Regent of Cryllor has commissioned a new force, dubbed the "Mountain Lions," to fortify Cryllor's western defenses.

Despite these efforts, humanoids and still less savory creatures have been able to elude the Keoish forces, sacking settlements, taking prisoners and burning croplands. Some have ventured as far as Crookhollow in the Good Hills (as described in KEO 2-08 *Pemlo's Lambic*).

There have been hints that a Suel mage is guiding these attacks and aiding the brutish orcs and giant kin to elude Keoish forces. This has not been verified. His identity remains a mystery.

In Crookhollow, a group of self-appointed "Guardians of the Highlands" have gathered. They worry the Kingdom has been slow to act; they wish to know the true nature of the threat from the west; and they want retribution for the massacre at Kilm. Their goals mirror those of the Countess of Flen. All they need now are some reliable adventurers willing to undertake a deadly mission on their behalf.

## Adventure Summary

---

Terrible forces have gathered in the shadow of the Jotens under the leadership of a Suel mage named Gwier Dreng. They are poised to attack the western counties of Keoland. In the past, the denizens of the mountains rarely rallied together: conflict between tribes kept them apart and individual, poorly organized

bands of raiders proved little challenge for Keoland's military. Things have changed. Gwier Dreng has united the humanoid tribes and giant kin using fear to bind them to his will. The Suel mage and the Lords to whom he swears fealty are mighty and terrible. Gwier Dreng plans to use this force to rectify crimes against his family and to reclaim his ancestral lands.

Pemlo Penchant, the venerable halfling brewmaster of Crookhollow and erstwhile adventurer, was one of the first to recognize the threat. In frequent travels through his beloved highlands he spied strange and deadly creatures roaming far from their mountain haunts. When prudent (and often when not) Pemlo challenged the interlopers, sending some fleeing and some to their graves. His efforts to rouse the local authorities to arms, however, have not met with success. The elders of Crookhollow believe the troubles stem from a brief and transient period of unrest brought by the wars against the giants in Sterich and Geoff.

Close calls in recent encounters led Pemlo to realize that he's no longer in his prime, so he turned to others for aid. Last year, Pemlo manipulated a group of adventurers into rooting out some of the creatures that had taken up residence near Crookhollow (see KEO 2-08 *Pemlo's Lambic*). Since then, he has gathered stalwarts of the Good Hills together as "Guardians of the Highlands." This group's purpose is to discover whoever or whatever is driving the monsters into the highlands. To achieve this, the Guardians once again turn to adventurers visiting Crookhollow for aid.

**Encounter 1:** The scenario begins at the Roc's Feather. Despite the troubles, Pemlo's brewery, "A Penchant for Drink," has had a banner year. The brewmaster invited all shareholders in the business to attend. Word of the meeting spread, prompting many speculators and party crashers to attend, including a few adventurers with full purses. Pemlo offers to repurchase outstanding shares and attendees may purchase shares at the going rate.

**Encounter 2:** After the meeting, Pemlo invites the PCs out for a nightcap. He tells tales about Crookhollow and recent adventures along the way. PCs are encouraged to do likewise - the grander the tale the better.

**Encounter 3:** Along the (rather circuitous) way, Pemlo leads the party to an old ruin. The "ruin" is actually a shrine to Brandobaris, the halfling god of thieves and adventure. This night, it is being used as a meeting place for the Guardians of the Highlands. If Pemlo is convinced that the PCs can help the Guardians, he solicits their aid.

Attempts to divine the identity or identities of those behind the raids have met with failure, but the

Guardians have not exhausted their resources. Padder Slipstone, a priest of Brandobaris and one of the Guardians, wishes to invoke a “Trial of Brandobaris.” This ritual will set Brandobaris’ chosen (halflings, adventurers) on a quest in the service of the halfling people and adventure. This Trial is a test of an adventurer’s mettle. It may be undertaken once in a person’s life and never leaves those that undergo the trial unscathed. Pemlo’s hope is that, if the PCs truly embrace the mission of the Guardians and undergo the trial, they will bring back a means to defeat the enemies of the Good Hills.

**Encounter 3:** The PCs undergo the ritual and are transported into a dark sewer. The magic of the trial places the PCs in Baelefract Keep where Gwier Dreng was born. After the death of the former Count of Cryllor, wizards in the employ of Ignaz Manz interdicted the keep. Now, the only access into the Keep is through the drainage system, a tight squeeze for creatures larger than tiny size. The magic of the Trial also shrinks the party, but this should not be obvious to them. In order to penetrate into Count Dreng’s sanctum and achieve their objective, the PCs must negotiate the perils of the drain, including flooding and (giant) rats.

**Encounter 4:** Within the sanctum, the PCs encounter the Ghost of Count Haight Dreng. In order to resolve the trial, the ghost must be defeated or convinced that the PCs are not his enemies and have the power to lay Lord Dreng to an eternal rest, reunited with his bride. The Ghost leaves behind a crumpled ledger page. This may lead the PCs to the County of Cryllor. Once the PCs retrieve the page they are transported back to the Guardians.

**Encounter 5:** The Guardians of the Highlands identify the ledger page. It was taken from the Chronicle of Cryllor, a record kept by the rulers of Cryllor. The Chronicles are preserved in the Archives of Cryllor. The Guardians believe this volume holds the information they require. Why else would Brandobaris have sent them to the keep? They ask the PCs to retrieve the Chronicle by any means.

**Encounter 6:** The PCs travel to the city of Cryllor and attempt to gain access to the archives. By diplomatic means, this is an almost impossible task. The Archivist is aware that the Chronicle records the final days of the Dreng family, the former royal family of Cryllor, and that access to these tomes is only granted to members of the Manz family or the Secretary of the Lady Regent. Barring tremendous favor with the Lady Regent, conventional access is impossible, but the PCs may obtain the Chronicle by utilizing the forgotten entrance provided by the Guardians.

**Encounter 7:** The PCs encounter a ghostly librarian within the Archives called a Copy Wight – a creature with which no adventurer has yet crossed swords.

**Encounter 8:** On their journey back to Crookhollow, the PCs encounter a strange pair on the road: an ettin and a Suel man dressed in green. Strewth lost his mate to adventurers one year ago. He now seeks revenge for her murder. The man in green is an emissary from Gwier Dreng, the Green Warlock. Gwier “had a sense” that the PCs carried something of value to him. The PCs and the Emissary may bargain over the Chronicle. In the course of this encounter, Strewth attacks the PCs and the Emissary is knocked unconscious. They PCs may find that the Emissary also carries information about the Green Warlock’s battle plans that could prove very useful to the Guardians of the Highlands.

**Conclusion:** Between the Chronicle and the emissary’s messages, the nature of the menace from the Jotens becomes clear. Armed with this news, the Guardians must now find a way to foil the errant Suel Lord’s plans. Pemlo happily rewards the PCs with more shares in the brewery.

It is also possible that the PCs were captured or surrendered after attempting to gain the Chronicle by force of arms. If this is the case, they are interrogated, and depending upon their actions under questioning and favor with the powers of Cryllor they may be released or imprisoned for a time. If the PCs are particularly imprudent in their confrontation with the agents of Cryllor, they may be executed.

## Preparation

In order to run all encounters smoothly and eliminate the need to ask to examine character records during play, it is suggested that certain information is requested of the players before the scenario begins. Collecting STR, DEX, AC, encumbrance (including what gear is typically carried), ranks in Swim and Balance and any adjustments due to armor and equipment will be helpful in running **Encounter 3**. In addition, the DM should ask each player to list her PCs favors; pay particular attention for PCs with the Favor of either the Lady Regent of Cryllor, her secretary, or Constable Merla Henning. (The first two favors could be obtained in KEO1-02 *A Little Reconnaissance*; the latter in KEO1-05 *All That Glitters* and/or KEO3-06 *Chain Reaction*). These favors will become important in the final encounter of the adventure.

## Introduction

The nobles of Keoland trace their ancestry back thousands of years to the Suel and Oeridian diaspora. They pride their pioneering ancestors on civilizing Keoland, the oldest of the New Kingdoms and forget the ancient peoples who worked the rich land of the Good Hills long before the founding of the original Suel Empire. Gnome, dwarf, halfling and even the human Flan delved deep, worked the land and lived in harmony long before the Great Migration. Those strange folk of the Hills are there still. Their civilization is unbroken. City folk and valley dwellers consider the Good Hills a queer place.

The people of the Good Hills are more familiar with arcane magic and more trusting of it, unlike in other provinces of Keoland. Strangers are more apt to find welcome than in the bustling cities. Even during troubling times, there is respect among the races -- though certainly gnomes, dwarves, Halflings and men have their differences -- most live in discrete communities.

And this is where you find yourselves. Your travels of late have brought you by winding highroad and by-road from the earnest dwarf town of Curget in the south through the glittering gnome village of Plim's Delve and finally to the halfling enclaves of the north-west. Travelers on the road warn you to be on your guard. Trouble's afoot in the prosperous highlands of the halflings. Things haven't been right since the savages sacked Kilm, they say. But since you're here now, you might want to stay. Pemlo's sent out notice on the four winds of some kind of party down at the Roc's Feather in Crookhollow. The halfling brewmaster might be a worse sot than Bucknard and older than "Old Squinty" himself<sup>1</sup>, but he's lively and the drink's sure to be fine.

Shareholders of "A Penchant for Drink" will receive a notice of the upcoming meeting carried by a messenger along the High Road (see Player Handout One).

### Encounter One: Shareholder's Meeting

The Roc's Feather, smack in the center of Crookhollow, has a capacity crowd tonight. It is

<sup>1</sup> This is a slang term for Vecna. Keoland is a very superstitious land, and mentioning the (real) name of the Whispered One in public is ill advised!

the windows. Inside, the halfling crowd is sprinkled with gnomes and a few dwarves for good measure. This event was held for shareholders of Pemlo's brewery, but it seems anyone craving a good ale muscled their way in -- unless all of them are shareholders. If that is the case, the stock being traded at the bar is probably worthless. Two nervous gnomes are desperately trying to sell shares as they watch their equity in the brewery sucked dry by the crowd of thirsty halflings.

The crowd here is seeking good food, drink and cheer: solace from recent troubles in the Hills. This is an opportunity for the PCs to meet and introduce themselves. It is also an opportunity for any gifted performers to shine. The crowd loves music. In fact, the atmosphere gives a performer a +2 circumstance modifier to her Perform check. Any performer choosing to make a perform check and exceeding a DC of 14 + (2 x APL) will be approached by Arl Buttermead (the proprietor) and given a bottle of Ole '68, a treasured brew of Lambic that's held up over the years. When drunk, the brew grants a PC a morale bonus equivalent in effect to the (1<sup>st</sup> level) bardic Inspire Courage ability but lasts for 10 minutes.

If PCs have not met Pemlo before, he will make an effort to come over and introduce himself. Pemlo was once an adventurer, but he claims to have retired from that profession long ago to pursue the true love of his life: fine ale. He spins grand (and unbelievable) tales of his youthful exploits that are spiced with imagination to a degree that anything he says could be considered a lie. The brewmaster appears to be a halfling of advanced age, but fit. PCs that have met him before will note that his hair is a bit thinner and his movement less agile. His purpose tonight is to disclose profits for the past year and buy back shares from current shareholders. If PCs have met Pemlo before, he will acknowledge them with a wink and a wave from across the room, promising to talk to them after the meeting.

At the bar, shares in the brewery are trading hands. Two gnome investors in the company [Trimble and Gimble], concerned that Pemlo is running the company into the ground, are selling. They are asking 75 gp per share, but they'll go as low as 45 gp in response to exceptional haggling. Pemlo has not informed the gnomes of his intent to repurchase shares at 75 gp (see below).

Taking advantage of a momentary lull in the chaos, Pemlo bashes his tankard on the bar and clears his voice to address the crowd. "AHM! Welcome friends, Crookhollowe'ens and, most importantly, shareholders in the brewery. How could it be that there are so many

shareholders here tonight? I must be gettin' senile. I only remember sendin' out 10 invites."

At that remark, the two gnome speculators at the bar blanch and break off their haggling. Pemlo continues, "I haven't seen so many creatures crammed in such a small place since I met that pilgrimage of Wastriggi outside the public outhouse in Gradsul. Anyway, I suppose you're wondering how business has been. With apologies to my gnome friends Trimble and Gimble over yonder, I must tell ye it's been a great year. Good King Kimbertos has a full cellar and that last lot of Lambic may have been the best since '68. I'm willing to buy any outstanding shares for 75 gp a share. M'boy Pasty will show you the books if you need to see them. That's all. So, let's set this business behind us and put this bar to its proper uses. Now Arl, open the taps."

If PCs wish, they may purchase shares above the rate that Pemlo offers from other shareholders. No more than 30 shares will be available and those will go to the highest bidder among the PCs.

**Development:** Pemlo will invite capable PCs for a nightcap at his home during the festivities, leading to **Encounter 2**. Note that Pemlo is looking for adventurers suited to undergoing the Trial of Brandobaris (see Encounter 3). He knows that this will place PCs in mortal danger, so it is not necessary that he like them, but he should respect their abilities. If, for some reason, a PC directly offends him or convinces him that they are unworthy of his trust (this does not necessarily exclude a thief or a rogue – he is a follower of Brandobaris, after all), Pemlo will not extend an invitation to that PC. The PC may tag along without an invitation or her comrades may make a Diplomacy check (DC 15 with appropriate circumstance modifiers at the judge's discretion) to encourage Pemlo to invite her, however.

## Encounter Two: Nightcap

After an evening of celebration, there can be little doubt that Pemlo's reputation as a brewmaster without peer is well deserved. As the last of the resident wee folk slip into a drunken slumber, and the last of the speculators have left, old Pemlo approaches. "The taps've run dry. What d'ye say, time to retire? Join me for a nightcap back home?"

Pemlo leads interested PCs out of the Feather and into the cool night air. Fog is rolling into the valley. All the stores and shops are closed, but PCs may wish to Gather Information from the small number of souls out and about. They may also note the reaction of the

townfolk to Pemlo. A Sense Motive check (DC 14) reveals that they feel uncomfortable or disdainful around Pemlo. This will not prevent them from taking his companions' money, however, it might be tougher for the PCs to haggle with them.

As they walk, Pemlo asks the PCs if they have had any excitement recently. PCs are encouraged to offer a tale of their adventures - the grander the tale the better. Take this as far as time and the party's inclination to roleplay permits. Pemlo loves to hear and to share shaggy-dog tales. He'll try to top any that are presented. If the party engages in these shenanigans, Pemlo is positively inclined toward them.

**Development:** Pemlo leads the PCs toward the shrine of Brandobaris. PCs will notice that the group is nowhere near the brewery or Pemlo's home. Give the PCs a chance to question Pemlo. He blunts questions with "Follow me. You're interested in a little adventure, aren't ye?" If they refuse to follow or, Yondalla forbid, misconstrue his evasiveness and attack him, resolve the encounter and end the module.

If Pemlo is attacked near the shrine of Brandobaris, the action is an affront to sanity and the halfling deity: Guardians of the Highlands subdue the party (don't bother or entertain running the combat; simply address it "off-screen" as the Guardians later release them, sans any gold carried, in the Moors).

Along the way, Pemlo will talk about the creatures he has seen in the area ("heavily armed orcs, great big wolves, giant ogres with three arms and three heads") and, if the PCs played *Pemlo's Lambic*, what they encountered in that scenario and comment, "Unfortunately, it's gotten worse."

Pemlo leads you down a winding path. The night is cool and damp. A mist rising from Sliver Creek has begun to blanket the valley. Finally, Pemlo stops. Before you, crumbling ruins of halfling earthworks are limned in fog suffused with moonlight. The dirt road gives way to worn paving stones that lead through an arch barely tall enough for a human. Pemlo turns to the party and gestures for you to step through the archway.

Do what you can to make the PCs apprehensive about passing through the archway. Pemlo waits for the party to enter. If asked where this leads, he responds simply, "Adventure." This is a shrine to Brandobaris, halfling god of thieves and adventurers. The archway radiates abjuration and transformation magic. It does not detect as good or evil. If the PCs delay in passing through the arch, he will say under his breath, "If walking through an arch gives 'em pause, perhaps they're not the men I thought they were." Should they delay a half-minute or

more, Pemlo will tell them, “I think now that this path is not for you. Let’s get that drink I promised.” After that, it requires a Diplomacy check (DC 12 + APL) to convince him that they are indeed the PCs he is looking for. Any PC may aid the roll and the judge may grant circumstance bonuses based on convincing role-playing. If they do not proceed through the archway, the PCs eventually return to an inn – at which point, the adventure is over for them.

Once the PCs issue though the archway, those that have been keen to watch Pemlo should be given Spot and Listen checks. Spot checks of (DC 12 + APL) or better will notice him reach into a pouch and throw a pinch of powder on the ground as he crosses the threshold. This is silver dust, an offering to his god. Those that make a Listen check (at the same DC) hear him say, “May the leading edge strike my foe” in the halfling tongue. A worshiper of Brandobaris, or a Knowledge: Religion check (DC 18) will identify the phrase as a common invocation to Brandobaris.

The path leads through mounds of earth to a circular clearing covered with mist. A low wall encloses the space. This, perhaps, was once a courtyard fallen into disrepair. An orchard has grown close to the ruin and overshadows a section of the wall. You notice another path at the opposite end of the courtyard and, in the distance, another archway.

Once everyone is in the courtyard, Pemlo reveals why he brought the PCs here.

Pemlo clears his voice. “I don’t mean to be melodramatic, young folk, but something bad is coming to the Good Hills. That’s why I brought you here tonight. This is an ancient shrine to The Whisper in the Night. With your help, the magic of this place may help us find out who or what is sending monsters into the Hills.”

As Pemlo says this, cloaked figures of various heights and builds step from the shadows of the orchard. The first of the figures draws back his hood. He is a middle-aged halfling man. He speaks in a gravelly voice. As he comes closer, you notice a scar corded around his neck. “We call ourselves the Guardians of the Highlands. The magic of this place has been used to test followers of the Whisper. Once in a man’s life, those of His ilk may undergo a Trial. Should he succeed, he is granted an answer, a clue to point the way, a gift, a means to realize his dreams. Should he fail, the consequences may be dire, for the Trial is a mortal one. You are followers on the Whisper’s path. Will you undergo the Trial?”

The hooded halfling is Padder Slipstone. He is a priest of Brandobaris. The Whisper in the Night is, of course, another name for Brandobaris. A worshiper of the god will know this, and a Knowledge: Religion check (DC 15) will reveal this. Pemlo walks over to the other shadowy Guardians while Padder Slipstone continues addressing the PCs.

The PCs will likely have questions. Padder Slipstone will answer them. He will give truthful answers to questions about the purpose of the Guardians and the attacks that made them aware of the threat. Other questions he will answer playfully or with a question of his own. He is evasive about the identities of his fellow Guardians. Specific questions likely to be addressed follow:

**Who is the Whisper in the Night?** “He is my guide. He hides behind the moon. He is the shunned protector of my people and patron of people like you. He is the double-edged knife blade.” [He is Brandobaris, and, after this description, a Knowledge: Religion check (DC 13) reveals this and the fact that Brandobaris is the halfling god of thieves and adventurers. He has a shady reputation, even among halflings.]

**Who are you?** “I am Padder Slipstone, a follower of the Whisper.”

**What exactly are you trying to accomplish?** “Attempts to divine what is behind the raids have met with failure. Pemlo’s hope is that, if the PCs truly embrace the mission of the Guardians and undergo the Trial, they will return with information or a tool that will help the people of the western counties defeat their foes from the Jotens.”

**How do you know that there is “something bad coming?”** “There have been many bad omens. Since marauders from the Jotens razed Kilm, attacks have continued with less severity but greater frequency. They are organized and we believe many prisoners have been taken, possibly as slaves, possibly as food. We don’t know.”

**What is this trial?** “The Trial is a test of an adventurer’s mettle appropriate to a particular place and time. It may be undertaken once in a person’s life and never leaves those that undergo the trial unscathed. This ritual will set one of Brandobaris’ chosen (halflings, adventurers) on a path to achieve their desires.”

**What happens to those that succeed?** “They are rewarded. The trial changes them.”

**What happens to those that fail?** “Some die, many are changed by the experience and wish they had died.



Their dream is ever out of reach, until they are redeemed.”

**What is that scar around your neck?** “This? This is a mark of stupidity. The wise man knows whom to trust. I was not wise, and nearly hanged for it. Fortunately, the favor of my master was with me. Luck is a blessing of the Whisper.” [The scar is a strangulation wound from the hangman’s noose.]

If the PCs *detect magic*, this courtyard and the archway, several items and two small figures (there are six in all, including Pemlo and Padder) can be identified as magical. If they *detect evil*, none of the Guardians registers as such. If they *detect good*, two figures, including Pemlo, and a tree overhanging the wall detect as good.

**Development:** At this point, Padder asks the PCs once and for all if they will undergo the Trial. It is possible that they refuse. Certain characters (lawful, suspicious of magic, mistrustful of demi-humans, opposed to Brandobaris and his followers, etc.) may be disinclined to aid the Guardians. If so, Pemlo will explain that their help could mean the difference between peace and war in the Good Hills, and that they could save many lives. If a PC continues to balk, Pemlo accepts that PCs decision and moves on to other members of the group. He won’t beg a PC to go, nor will he think ill of a PC that initially decides against going and subsequently changes her mind. The adventure is over for any PC that decides against continuing. (At the DMs option, a PC could aid in the second part of the module, when the PCs head for Cryllor; the PC gets XP only for the portions of the module in which they were physically present and contributing to the success of the party).

If a PC is unredeemably boorish and insulting to Pemlo and company and the other PCs choose to undergo the Trial of Brandobaris, there is little recourse for that PC but to wait until the others return. Padder Slipstone will not perform the ritual for such a character.

The exact stats for the Guardians are not relevant or needed by the DM; if a fight ensues, all of them will blend seamlessly into the shadows and leave the PCs. The adventure is over for this party of ham-handed PCs!

## Encounter Three: Baelfract Keep

Padder Slipstone asks the PCs to gather around him in a circle. He opens a leather pouch strung to his belt and pulls out a small jar and paintbrush, then asks each of the PCs to step forward in turn. In the halfling tongue

he chants a prayer to Brandobaris to guide the way and paints a silver dagger (the symbol of Brandobaris) on their skin in a place exposed to the moonlight. The paint burns like acid and the wound issues a few drops of blood before clotting. Padder comments, “He IS the double-edged knife. This is a reminder.”

As the priest conducts the ritual, the fog thickens in the courtyard, diffusing the light of a waxing Luna and crescent Celene. The soft white light sets the shadowy archway at the other end of the courtyard in stark contrast. Padder addresses you again in his gravelly voice. “You must pass through that arch, then your trial will begin. Keep your goal in mind as you go through. Discover who or what is behind the attacks.”

As you move toward the archway, Pemlo shouts, “Wait a moment!” and runs over to you. “I promised ye a nightcap.” He pulls out a flask and passes it among you. “I took the same path a lifetime ago and I’d do it again if I could. Here’s what I learned about the Whisper during my trial: He’s a trickster, but in the end he sets ye on the right path. When the Trial’s done, he’ll bring ye back.” After a sip from Pemlo’s flask, a warm and tingly feeling spreads from your belly all the way to your fingers and toes. It fills you with confidence to face the challenge ahead.

The archway is four feet wide by six feet high. PCs must pass through it to undergo the Trial. Ask each PC what their goal is as they pass through. If it does not match, to great extent, the consequences are described in the **Development** section of *Area Two*.

The PCs are transported into a dark sewer. The trial has placed them in Baelfract Keep where Gwier Dreng, leader of the enemy forces was born. After the death of the former Count of Cryllor, Gwier’s father, the keep was interdicted by wizards in the employ of Count Manz, the new ruler of Cryllor. The Keep also possessed wards of its own, for in his advancing years Count Dreng was possessed with deep paranoia. Now, access can only be had through the drainage system, a tight squeeze for creatures larger than Tiny size. The magic of the Trial also has shrunk the party, but this should not be obvious to them.

As you continue through the archway, the stonework changes. Worn gray paving stones give way to almost seamless, slick, dun-colored masonry. Luna winks out, leaving you in darkness.

The PCs are in a drain with no light source. This should not be obvious to them. Medium sized characters have been shrunk to Diminutive size. Small characters have been shrunk to Fine size. The effects of the shrinkage are (from a game mechanic standpoint) minimal.

Creatures in *Encounter Three* are scaled to account for the size difference, and the small areas in which the PCs find themselves are proportionally indicated in the maps. There are a few things about which the DM must be aware, however:

- This magic comes from Brandobaris and cannot be dispelled by any means available to the PCs at this time.
- A dwarf may make a search check on this stonework assisted by Stonecunning. A DC 16 check will reveal the grain in the stonework to be unnaturally large. Alternatively, a Search check made against the stonework allows a separate Int check (DC 16) to notice the same thing.
- Note that spells (and other visible spell effects that are fixed in size), from the PCs perspective, seem to be enlarged here. Do not bring this to the PCs attention. Simply indicate what they can see when asked. Remember, the relationship between something's real size and its perceived size to the PCs perception is 5:1.

The will of Brandobaris will not allow the PCs to pass out of the Keep once this threshold is crossed. This is a Trial, and the PCs have chosen to take it. Thus, they cannot leave except through failure or the completion of their goals. If the PCs look behind them, they will not see the arch or the courtyard in Crookhollow. Rather, they stand immediately before a precipitous drop down a narrow metal shaft. (This is a downspout!)

### **Area 1. Blame it on the Rain**

The PCs come to a shaft up. The shaft appears to end 60' above before continuing horizontally.

The difficulty of the climb increases by APL. At higher APLs, the stone is covered with slime. Have the PCs make five Climb checks (DC 20 + APL free-climb; otherwise set DC as noted in the skill's description in the *Player's Handbook*) if they do not bypass the climb using other means. Only use the first roll in the set. If they fall, roll 1d6 of subdual damage for falling. If they question why only one die of damage was rolled, indicate they fell during the initial part of the climb.

DM Note: Despite the size change, falling damage is not reduced in the game; this is the reason behind the smaller amount of damage (since the PCs are actually only falling one fifth of the height they perceive). Don't let PCs falling damage work to allow them to discern that they have been reduced in size – if need be, assume they make the rest of their climb checks regardless of the roll.

Keep careful track of the amount of time the PCs take to climb, and remember that each time a PC “takes twenty” on a skill check, two minutes (twenty rounds) or more has passed!

Two minutes after the first PC reaches the top of the shaft, the sound of distant thunder is heard. One minute (ten rounds) later, a rumbling in the tunnel is heard. The passage is about to be flooded with rainwater. PCs have four rounds to act before encountering the torrent. The flood continues for ten rounds. (If PCs have made it to *Area Two* at this point, they will be safe)

*PCs at the top of the shaft in the passageway* that have not made specific (and possible) efforts to secure themselves must make a pair of Balance checks (DC 10 + APL of the adventure). Success on both rolls indicates the PC has found a good point from which to hold steady, and no further checks are required. Failing one check indicates that the PC has been swept off her feet – her Balance check's DC in the following round is increased by +2. If a PC fails both checks in a single round, they are blown off their feet and swept over the edge. If the PCs have anchored ropes, *immovable rods*, or something else that the PCs might be able to grab for as they fall, allow a Reflex save (DC 15 + APL) to arrest their plummet.

*PCs in the shaft* must make Climb checks (DC 13 + APL) to retain their footing or grip and keep from being swept down the shaft. (Remember that some PCs may be safe because they are flying, levitating or whatnot) PCs that are knocked loose fall for 1d6 subdual damage and will find that they have been swept to the downspout (see below).

*PCs swept or falling into the downspout* will find that while the narrow shaft is not wide enough for them to be forced through by the rain, their occlusion of the shaft causes the area to flood. All PCs present must make a Swim check (DC 20) or suffer the effects of such a failed check as described in the *Player's Handbook*. (Note that the churning water should be considered “Stormy Water” with a DC 20 check, and as such does not allow PCs to “take ten” on a check.) Each round a PC in the downspout fails a swim check, the pipe is considered occluded. For each round the pipe is occluded, add one round to the duration of the flood. Remember, without occlusions, the flood should last ten rounds.

DM Note: Because of the threat of drowning, this encounter is treated as a hazard with an EL equal to the APL of the adventure.

**Development:** Add urgency to the situation with the sound of thunder and the threat of rain and flooding.

PC's should be encouraged to proceed quickly to **Area 3**.

### Area 2. Rats!

There are two levels to this room. On the lower level, several drainage pipes converge. The higher level provides passage to Count Dreng's sanctum and contains (from the PC's perspective) titanic rats. There is a fifteen-foot climb (PC perspective) from the lower level to the higher.

When the PC's ascend to the higher level, read the following:

Rats of immense proportion occupy this chamber. They are several times your size, their eyes are filled with fire and cruel tusks jut from their lower jaw. They advance, salivating, starving, and eager for a snack. From where you stand, you feel the heat and stench of their breath.

---

### APL 2 (EL 2)

**Dire Rats (3):** See *Monster Manual* page 64.

---

### APL 4 (EL 4)

**Dire Rats (Advanced, 2HD) (3):** See *Appendix One*.

---

### APL 6 (EL 6)

**Dire Rats (Advanced, 3 HD) (4):** See *Appendix One*.

---

### APL 8 (EL 8)

**Dire Rats (Advanced, 6 HD) (3):** See *Appendix One*.

---

### APL 10 (EL 10)

**Dire Rats (Advanced, 6 HD) (5):** See *Appendix One*.

---

### APL 12 (EL 12)

**Dire Rats (Advanced, 6 HD) (8):** See *Appendix One*.

Note that at APL 8 and above, these rats transmit deadlier disease than their lesser fellows, and do so by touch. (See the *Dungeon Master's Guide* for rules on diseases)

APL 8: Slimy Doom - Fort save DC 14; APL 10 - Fort save Blinding Sickness: DC 16; APL 12: Demon Fever - Fort save DC 18.

**Tactics:** Two rats will advance, while the others delay until all PC's have acted. The rats will attempt to bull's rush any PCs they can from the upper level to the lower level, whereupon the rat will attack others remaining in

the upper portion of the chamber. Only if/when all PCs have been knocked down below will the rats attack them there.

Use of powerful area of effect spells will ensure the Count is not flatfooted when encountered. Remember, area of effect is unchanged by the reduction effect. When the PC targets a vertex, the effect springs forth from that spot, apparently five times larger than normal.

**Development:** PC's may proceed out of the rat holes in the crumbling wall and into the anteroom detailed in *Encounter Four*. If powerful spells were cast that exceed the dimensions of the drainage system, the vibrations have alerted Count Dreng. From this point on, treat him as though he is in combat. He will not be flatfooted and will have circumstance modifiers affecting PC Diplomacy checks. PC's that did not have the Guardians' interests at heart when they pass through the arch fall into a comatose sleep until their comrades return and have a dagger branded on their skin where Padder Slipstone painted the symbol of Brandobaris. Consequences are listed on the AR. Resume play with this PC in *Encounter Five*.

---

## Encounter Four: Meeting the Count

---

The rats have dug holes through the crumbling wall that lead to the anteroom (Area 3). Each minute a PC is out of the confines of the drain, she increases one size category. Within three minutes, the character increases to full size. Until that time, for simplicity, treat the character as if they were under the influence of a **Reduce Person** spell.

**Consult DM Aid Two:** Map of the Sanctum of Lord Dreng.

### Area 3: The Anteroom.

You emerge from the tunnels into a massive hall. Double doors on either side must be 50' tall. It would take a storm giant to reach the doorknobs. Lightning strikes illuminate colossal moldering furniture. You feel dizzy for a moment, but it passes -- perhaps vertigo brought on by the bizarre proportions of the room. A second flash glints off of a gargantuan statue wearing half-plate and armed with a glaive towering far overhead.

The dizzy spell is actually a sign that the reduction effect is wearing off. PCs may explore this well-appointed sitting room. There is little of interest to adventurers save the armor suit and glaive, though a relevant Craft or Knowledge: Local (Metaregion One)

check (DC 13) can identify the furniture is of Crylloran make and once of fine quality.

If a PC moves quickly, she can make it under the door into Count Dreng's sanctum. Otherwise, the PC's must figure out a way to open the door, bypass it or wait until they have grown at least to small size. The doors are locked. The other door opens to a bare wall devoid of a secret door – Brandobaris wants the PCs to finish their task, after all, and not explore the keep.

**Wooden Doors:** 2 in. thick; hardness 5; hp 20; AC 5; Break DC 22. Open lock DC 15.

**Development:** If the PCs rest here, the Ghost of Count Dreng will manifest in this room on a random watch and attack. Allow the PCs on guard a Spot check to avoid surprise.

#### Area 4: The Sanctum of Count Dreng

Count Haight Dreng ruled Cryllor before Ignaz Manz, the current ruler, became Count [Manz has been incapacitated by a mysterious illness and the Lady Regent, Lady Lora Manz rules in his stead]. Tragedy after tragedy befell the Count, taking each of his daughters and his young wife. Finally, Gwier, his son and named heir, left the County called to a life of adventure, never to return. Months after his departure word came to Haight Dreng of Gwier's death in the Jotens. Count Dreng, inconsolable, died soon after, reputedly of a broken heart.

The motto above the double doors within the sanctum ["We will remain" – in Ancient Suel] suggests the party's present location and related information to a PC with a Bardic Knowledge or relevant skill check (Knowledge: Nobility & Royalty of DC 13, or Knowledge: Local [Metaregion One] at DC 18 will do). A successful check will provide additional information, as follows:

This is likely Baelefract Keep on the Dreng ancestral lands, near the borders of the Good Hills and the County of Flen. It was magically sealed off after Count Haight Dreng's death. Word spread that the former Count was a practitioner of dark magicks, which eventually turned on those he loved and on himself last of all. The Keep has been abandoned since.

The spirit of the Count has not abandoned it, however. He was convinced there was a conspiracy against him until the day he died and will not rest until the crimes against the Dreng family are brought to light. Count Dreng clutches in his dead hand a clue to the crime and to the identity of the leader of the forces from the Jotens, his son Gwier (whose death was greatly

exaggerated). It is a page from the Chronicle of Cryllor, the official record kept by each ruler of the County.

The ghost knows and at the same time does not know he is dead. It assumes all that trespass here are traitors that have come to kill him and seize power.

In order to resolve the Trial of Brandobaris, the ghost must be defeated (the likely path to victory) or convinced that the PCs are not his enemies and that they have the power to bring his enemies to justice and lay him to his eternal rest, reunited with his bride (an unlikely, but possible path to victory).

If PCs have the presence of mind to attempt Diplomacy with the ghost of Count Dreng, he must first be convinced he is dead (DC 12 + APL) and second, convinced that the PCs are not "out to get him" and capable of bringing to light the conspiracy against his family (DC 20 + APL). Modify rolls appropriately due to the circumstances. Obvious or apparent agents of Cryllor or the Good Hills will receive a –2 modifier. If any of the PCs have taken the armor or glaive from **Area 3**, assess and additional –2 penalty. Obvious or apparent worshippers of Kelanen will receive +2. Suel nobles (or those appearing like they could be, with Suel features) receive +2. Clerics of Kelanen get +4.

Lightning from the passing storm illuminates this chamber through narrow twenty-foot tall windows spaced evenly about the perimeter. The crest of Keoland on the opposite side of the room marks it as the sanctum of a lord of Keoland. The vaulted ceiling reaches forty feet into the air. Above the doorway through which you entered the crest of Cryllor is emblazoned. Below it, words are inscribed in Ancient Suel. A large table and ornate chairs dominate the center of the sanctum. Bookshelves ring the room. The very air here seems to reek of hatred and fear. A single skeleton, clad in moldering, once-fine robes, sits on a grimy throne. A yellowed piece of parchment remains clutched in its bony right hand.

The creature in this room will manifest when at least one PC has advanced more than thirty feet into the room.

The mouldering bones crackle and spark and a luminous form rises, wailing, from the decay. "Thieves and assassins! You sneak into my sanctum for your bounty and my life. I assure you death is all that awaits you!"

#### All APLs (EL Varies)

**The Ghost of Lord Dreng:** hp varies; see *Appendix One*.

**Description:** The Ghost wears the spectral clothes of a high-ranking Keoish noble. About his neck is a medallion of office (Cryllor). It appears his face is blackened and swollen (a DC 15 Heal check will identify this as the effect of poison). The Ghost emanates a spectral light and exudes waves of hate and fear. He wears the rich jewelry of a noble befitting his station.

**Tactics:** This can, and should, be a difficult combat at all APLs.

**APL 2:** The ghost will manifest and move close to a PC that resembled him in life (in order of preference: male, human, Suel, mage) then use the malevolence ability to try to possess him. If successful, he will use the inhabited body to attack until it falls, then move on to possess the next. An attempt to parley, while all PCs obviously hold all attacks, accompanied by a DC 15 Diplomacy check will momentarily stay his attack.

**APL 4:** Same as above, but he will first cast *mage armor* and attempt to hit enemy fighters with *ray of enfeeblement*. If applicable, make an arcane spell failure check casting spells once he possesses a body.

**APL 6:** The ghost will first cast *blindness* on two foes (starting with fighters) then continue with spells against foes with sight, preferring *magic missile* and *blindness* to *ray of enfeeblement*. An attempt to parley, while all PCs obviously hold all attacks, accompanied by a DC 21 Diplomacy check will momentarily stay his attack.

**APL 8:** The ghost passes through the floor and casts *mage armor*, *Longstrider* and *resistance* upon itself before engaging. It follows this by casting *web* on PCs standing between anchor points, and then follows with *blindness*, malevolence and *vampiric touch*. An attempt to parley, while all PCs obviously hold all attacks, accompanied by a DC 24 Diplomacy check will momentarily stay his attack.

**APL 10:** It will sink and cast personal enhancement spells, as noted above. The ghost will then rise from the floor and issue a frightful moan. It will note spell effects on characters that remain and cast *dispel magic* (targeted or area as seems reasonable). It will then cast *bestow curse* (using the curse option of a 50% of victim inaction), followed by the tactics used above.

**APL 12:** Same as above, but it will also cast *see invisibility* and *improved invisibility* on itself when it buffs. It will not use *blindness* unless the *invisibility* is dispelled. When in the sanctum, it will always hover out of standard combat range. It will attempt to *feblemind* spellcasters, then open up with area of effect damage spells. While invisible, the ghost will

make certain to move immediately after casting, so as not to allow the origin of its spells to betray its location.

**Treasure:** Unless PCs are looting the room when fighting or talking with the Ghost, the only treasure they are able to retrieve is the medallion of office. If they do loot, they can retrieve several valuable books (50 gp x APL). At APL 12, the items possessed by the ghost can be retrieved (see *Appendix One*).

**Development:** If slain (again), the Ghost sobs: “Murderers ... I knew your master Ignaz would send you. Now I die and this once proud realm falls into darkness.” Once Lord Dreng’s spirit dissipates, it leaves behind a crumpled ledger page, documenting the last days of his life.

If his assistance is won with Diplomacy PCs find his memories are mainly of Count Manz, who he hates. He remembers that when he died, he seized a vital piece of paper from an equally important book of equal importance. He motions to his remains and tells the PCs to take the page, and passes along his medallion of office. He asks them to leave it on the grave of his son. With that, he disappears.

Once the PCs retrieve the page they are transported back to the shrine of Brandobaris.

## Encounter Five: Return to the Guardians

---

Once the page is retrieved from the Ghost, the magic of the Trial returns the party to the courtyard. Those that were found wanting (drowned, trapped in Area 2, or slain by the creatures of Baelefract Keep) return changed. They are under the effect of a permanent *reduce person* spell and the painted silver dagger has been etched upon their skin (refer to the AR) – reminders of their failure. The deceased have a *raise dead* bestowed upon them, though they suffer loss of XP and 950 GP as normal (over the course of the next few days, PCs will discover it is missing – taken by Brandobaris himself! If a PC does not have sufficient funds, the PC will find as close to the total in coin [not items] has been taken).

This is an opportunity for the Guardians and the party to compare notes. If given the opportunity to examine the document they retrieved, Padder Slipstone is able to identify it as a page from the Chronicle of Cryllor, a record kept by the rulers of Cryllor that documents Crylloran policy, meetings with dignitaries, treaties, etc. These records are preserved in the Archives of Cryllor. The document has a mark that identifies the volume and is presented in *Player Handout Three*.

Though the document and the encounter may lead PCs to suspect foul play in Count Dreng's death, it is not in itself the information the Guardians sought. Padder Slipstone believes more information might be gleaned from the rest of the volume, which can only be obtained from the County Archives in Cryllor.

When the Guardians mention Cryllor and Count Manz, they do so with obvious distaste. Relations between the Good Hills Union and the County of Cryllor have been strained for many years, and the Count has threatened to take control of their kinfolk's land in the Little Hills.

**Development:** It is again decision time for the PCs. The Guardians will ask the PCs to journey to Cryllor to retrieve the Chronicle, urging them that the information contained there might bring an end to the threats against the Good Hills. Pemlo will urge that "the Trickster set ye on a path, and ye'd best be off to see it through." The adventure ends here for PCs that won't continue; the DM should calculate GP and XP for their participation up to this point.

## **Encounter Six: The Library**

---

If the PCs accept the mission, they must travel to the city of Cryllor and attempt to gain access to the archives. The trip will take a few days along a well-used road, during which nothing will trouble the PCs.

### **Acquiring the Tome via Influence:**

By diplomatic means, this is an almost impossible task. Allow a PC to make a Knowledge: Nobility and Royalty check (DC 15). Explain to any PCs that successfully make the check of the procedure involved below; they may find that they are unable to do or provide what is required of them, and could save them the needless expenditure of influence points on an unachievable goal.

First, PCs must gain an audience with the Lady Regent. The PCs can expend a single point of influence with the Lady Regent's secretary, Delana (gained in KEO1-03 *A Little Reconnaissance*) to do so. Alternatively, Constable Merla Henning could be asked to write a letter of introduction for the heroes; this would require spending two influence points with her (gained in KEO1-05 *All that Glitters* and KEO3-06 *Chain Reaction*).

Once the PCs have gained an audience, the Lady Regent must be swayed. A total of number of influence points with the Lady Regent of Cryllor equal to the number of PCs in the adventure may allow access to the archive. (Note: It doesn't matter whether one, some or all of the PCs are asking for access to the tome – this number is set) Alternatively, each PC can make either a

Bluff or Diplomacy (not both) check (DC 20 + APL of the adventure), with each success reducing the amount of influence points needed to gain access by one per successful check. The DM is encouraged not to make this a strictly mechanical process – instead, roleplay the PCs attempting to gain audience.

If successful, the PCs will bypass *Encounters Seven* and *Eight*, but the PCs should still be awarded experience as if they overcame these encounters. (Indeed, by eliminating the need to go through them, they have, and it would be grossly unfair to penalize players for coming up with a solution that did not involve acquisition of the book by force or theft!) Proceed to *Encounter Eight*.

If the PCs cannot muster the necessary influence, they are politely – but firmly – rebuffed.

### **Acquiring the tome via force:**

Disastrous. Consult *Appendix One* for details on the guard contingents around the library. An assault on the library will bring guard contingents to battle intruders. The initial guards will attempt to subdue the PCs; if any of their number are slain or magically disabled, they stop and begin trying to *kill* the PCs. One squad of guards (as listed below) will show up every minute until the PCs are stopped. Merla Hennig, constable of Cryllor, will join the third squad of guards. Check the AR for the ramifications of this decision. Also note that this does not exclude these ham-handed PCs from having to deal with the encounters inside the library!

### **All APL's (EL 8)**

**Crylloran Guardsmen, War2 (8):** hp 18; see *Appendix One*.

**Constable Merla Henning, Rog4/Wiz2:** hp 24; see *Appendix One*.

### **Acquiring the tome via guile or intimidation:**

The Archivist (see Area 2) controls access to the Restricted Archives. He holds the keys. It is possible to Bluff or Intimidate him into providing access to the Restricted Archives. Under no circumstances can he be convinced to grant access to the Special Archives by such means. DCs for success are 16 + APL.

PCs may also attempt to charm the Archivist to gain his assistance.

If the PCs employ these means and they fail, he will call for help. This will result in the same consequences as if they attempted to **acquire the tome via force**.

### **Acquiring access using Gather Information:**

There is an alternate route into the Restricted Archive. It was dug during a renovation of the Archives by an unfortunate contractor by the name of Owent Lugs. Lugs was “convinced” to make the modification by an underworld figure who needed access to records kept by Cryllor’s Constabulary. After concluding the renovations, Lugs dropped off the face of Oerth.

PCs can discover this information with a skill check DC 14 + APL. Membership in a Keoland thieves’ guild or the Alleyway Defenders gain this information automatically (provided that they ask of course).

In this tunnel, there is a bricked up alcove. If PCs investigate, they find the decomposed body of Master Lugs. The tunnel leads to the secret door in the Restricted Archive indicated on **DM Aid 3: Map of the Archives**.

### Area 1: The Archives

City residents and officials can easily point the way to the Archives. The Archives were built centuries ago and expanded under Count Manz’ rule.

The County Archives were built in the classical style centuries ago. It is more in character with the architecture of Nirole Dra, constructed of white marble shot with gray, stout pillars supporting the inverted V of the roof and the imperial lion of Keoland ever present in elements of design. Two great maned marble beasts guard the main entrance. More ominously, a detachment of Crylloran militia is also stationed outside.

Within, the Archives contain a rare trove of information, serving as library, clerical hall and repository of public record. Access to the books of the archives is a wonder to modest citizens of Cryllor (though the literati of Gradsul and Greyhawk would find it a dry and quite limited collection).

If the PCs ask, any librarian can point them to the Restricted Archives, where the volumes of the Chronicle are kept, though they advise, “You will need the permission of the Archivist to be admitted. Lucky for you, his office is right outside.” A short distance away down a corridor just off the main entrance the PCs find the office of the Archivist. Across from open doorway (there is no door) is the gate leading to the Restricted Archives.

### Area 2: Office of the Archivist

Among the public officials of Cryllor, the Archivist is perhaps the most anti-social. Play him as a disgruntled and unhelpful civil servant. He does not wish to be bothered with requests for common documents. Those requiring special care and oversight are to be declined

at all costs, unless they come from the highest-ranking officials of the County. He has been instructed by Darvis Albrect, a special functionary of the Secretary of the Lady Regent that no one under any circumstances, save the Secretary, the Lady Regent or Count Manz himself, are to be permitted access to the Chronicle. He is aware that the Chronicle, specifically the volume the PCs are interested in, records the final days of Dreng family rule in Cryllor. The Dreng Family ruled Cryllor for centuries before Count Manz came to power. He is unaware that the Chronicle might contain information indicating a plot against the deceased Count Dreng.

PCs are unlikely to gain conventional access to the restricted archives, though it is possible (see above). Once within the Restricted and Special Archives, the PCs must find and retrieve the Chronicle.

A guard contingent (see above) checks in with the Archivist every ten minutes.

### Area 3: The Restricted Archives

The PCs must overcome two additional obstacles once they get past the Archivist.

#### The Gate and Grill

A gate screened by grillwork protects the Restricted and Special Archives. The Gate is made of steel and is locked. Sound will carry through the grillwork quite easily. PCs must be sensitive about the noise they make lest guards and patrons be alerted.

**APL 2 – 4: Lock:** 1 in. thick; hardness 10; hp 10; AC 5; Break DC 26; Open Locks DC (16 + APL). **Gate and Grillwork:** same as above (cannot Open Lock).

**APL 6 – 8: Lock:** 2 in. thick; hardness 10; hp 20; AC 5; Break DC 32. Open Locks DC (20 + APL). **Gate and Grillwork:** same as above (cannot Open Lock).

**APL 10 – 12: Lock:** 3 in. thick; hardness 20; hp 30; AC 5; Break DC 38. Open Locks DC (24 + APL). **Gate and Grillwork:** same as above (cannot Open Lock).

#### The Portal

Pangle Stoone of the NAW was retained by Count Manz to set this ward. The gnomish arcane trickster had some fun in completing his contract, much to the chagrin of the Archivist. He crafted a classical doorway, with fluted pillars of marble framing the sides and classical relief work bearing a frieze and human bust at the top. Stoone found the Archivist a trifling bore and chose to immortalize this librarian’s profound superfluity in the marble bust. It resembles the Archivist and wears a foolish look on its face. When first encountered, the bust looks down upon trespassers seemingly poised to speak. The door itself is secured

with a non-magical lock (Open Lock DC as for the gate above) and an *arcane lock* (with a caster level equal to APL + 3). The portal radiates *abjuration*, *conjuration*, *enchantment*, *illusion* and *transformation* magic. If it has not already occurred to an individual examining the door, a successful search check will indicate that the door operates on some common command. Once commanded to "speak," the bust animates. Note that the bust responds to verbal commands and cannot read lips, so a *silence* spell will prevent the bust from responding.

The magical portal has a sense of humor -- feel free to ham this part up. For instance, if the PC speaking to the bust is whispering commands in the hopes of activating it, the bust will animate and say in an uncomfortably loud voice, "MY PLEASURE. WHY ARE YOU WHISPERING?" The voice is that of the Archivist, the tone that of a simpleton. The bust will respond to four commands: **Speak**; **Silence**, which mutes the sound, though the lips can be read if a PC has the required skills; **Quiet**, which forces the bust to speak in a whisper; and **Shhh**, which functions the same as Quiet.

Once activated, the bust will converse inanely with the PCs until asked to be let through the door, whereupon it says, "Oh, you want to hear the riddle for the day? [it looks closely at each of the PCs] Answer and pass:"

"You can find us in darkness but never in light. We are there in daytime but absent in night. In the deepest of shadows, we hide in plain sight. What am I?"

The answer is "the letter D" or just "D". Give the players *Player Handout Four*. After asking the riddle, the bust will start making clock noises or humming the theme to Jeopardy. Give the PCs one minute to come up with the answer. There is no penalty for answering incorrectly; the statue will just continue humming or ticking. If they remain in the restricted archives and have not given the correct answer after one minute, the following occurs:

- An area of effect *dispel magic* is triggered throughout the restricted stacks [Caster level equal to APL +3].
- All creatures in the restricted stacks must save against a *hold monster* spell [DC 16]. The spell lasts a number of rounds equal to the APL of the adventure.
- The bust begins to sing, loudly. This will alert the guards at the entrance to the archives (sonically), the Archivist and other Crylloran authorities (telepathically). The Archivist (if not incapacitated) and one detachment of militia (two if the PCs are followed after trying to speak with

the Secretary) will report in two minutes. If the PCs do not surrender or flee, this will continue as if the PCs tried to acquire the Tome via force.

The portal may also be opened with successful disable device and open lock checks, or simply broken.

**APL 2 – 4: Portal:** 4" thick masonry; hardness 8; hp 60; AC 5; Break DC 30; Disable Device DC (20 + APL); Open Locks DC (20 + APL).

**APL 6 – 8: Portal:** 1' thick hewn stone; hardness 8; hp 180; AC 5; Break DC 40; Disable Device DC (24 + APL); Open Locks DC (20 + APL).

**APL 10 – 12: Portal:** 3' thick hewn stone; hardness 8; hp 540; AC 5; Break DC 50; Disable Device DC (28 + APL); Open Locks DC (20 + APL).

If the disable/open checks fail or if the door is attacked (or walls, ceiling or floor of the private archive), the effects above will be triggered immediately. Spells that affect (*disintegrate*, *passwall*), pass through (magically or physically; such as *clairaudience* or *prying eyes*) or otherwise allow scrying or passage through the portal must overcome the portal's SR of (15 + APL).

**Exception:** Ethereal creatures may pass freely into and out of the private archive.

**Development:** Depending upon play to this point, if any alarm has been triggered, guard detachments will respond.

## Encounter Seven: The Copy Wights

The PCs encounter a guardian that has been bound to service within the Archives, an ethereal spirit called a Copy Wight (see *Appendix Three*). The spirit has been charged to aid servants of the ruling house of Cryllor and to ward the archives from unauthorized individuals.

Beyond the portal, you find a large hall of black marble filled with row upon row of tall bookcases of iron and mahogany standing upon feet of delicate iron scrollwork. The cases are inscribed with a strange code, apparently indicating the types or categories of books they hold. As the hall is very dimly lit, it is difficult to tell the size of the restricted archive. One thing is certain: finding the Chronicle could take awhile.

The light in this room is magical. It is linked to pressure on the floor and will illuminate a 20' radius appropriate for reading around individuals standing on the floor.

Fitzhugh (see below) [and his cohort, Crickneck. Depending on APL] is alerted to the presence of the party by the library lights and/or a commotion. He will



allow them to find the tome they pursue and perhaps aid them in locating it (judge's discretion), querying them along the way about their identity and purposes. However, if the party is particularly intimidating, he will choose to hide in the stacks. He's a bit timid. If the party is approachable he will ask if he can be of service and may talk about how dreary and backward this Archive is. It is all tax rolls, political ledgers and official correspondence. He would much prefer fiction. Fitzhugh wanted to be a pirate, but his master told him to forget about that nonsense. After all, who ever heard of a Copy Wight pirate? Fitzhugh wishes one day to take a position in Greyhawk where they care about the Arts.

Before the party retrieves the Chronicle, Fitzhugh will abide by the terms of his service and attempt to prevent the PCs from taking it (unless they convince him they are agents of the Manz family – a Bluff of [DC 20 + APL]) or at least delay them until reinforcements arrive.

If the party kills Fitzhugh, he strives for drama and humor in his final words. He'll do a ridiculously drawn-out "death scene" ("Goodbye, cruel world!"). The DM is encouraged to act out the scene for comedy.

Histrionics concluded, the spirit thanks them for relieving him of this dreary duty in godforsaken Cryllor, his life measured away in teaspoons. Feel free to embellish the pathos. Finally, he mentions that he heard a good position was opening in Greyhawk soon and he wanted to submit his resume. As an outsider, Fitzhugh cannot be killed on this plane, and may indeed return to meet the PCs in a week's time.

#### **Creatures:**

Fitzhugh [and Crickneck, depending on APL] resembles a thin old man wearing spectacles, a charcoal vest and knickers. He has wispy silver-blue hair that floats about his head like a halo. In fact, his whole body is slightly luminescent. He moves nimbly, generally appearing to walk on the ground, though the lights of the room do not follow him and, at times, he may pass through the bookcases, walls, etc. Fitzhugh can fly, but rarely does so. His demeanor is that of a nervous scribe, but his inner child wishes he were a pirate. PCs with a nautical background – *especially* Dread Pirates – will see him fawning over them. Crickneck is the naysayer and pessimist, who makes it a point to always knock down whatever aspirations Fitzhugh has (accusing him of "putting on airs for the guests!")

---

#### **APL 2:**

**Fitzhugh: Copy Wight Apprentice:** 10 hp; see Appendix 3.

**Tactics:** He will ensorcell the restricted archives with Labyrinthine Confusion to delay the party, cast *sleep* on the fighters and try to disable spellcasters with *touch of idiocy*. At this level he will not employ hit and run tactics (such as using incorporeality to escape into solid objects).

---

#### **APL 4:**

**Fitzhugh and Crickneck, Copy Wight Apprentices:** 10 hp; see Appendix 3.

**Tactics:** same as APL 2.

---

#### **APL 6:**

**Fitzhugh, Copy Wight Scribe:** 30 hp; see Appendix 3.

**Tactics:** He will cast *mage armor* on himself before addressing any PCs. He may lead with *deeper slumber* before using touch attacks and use ethereality to his advantage, moving in and out of the stacks.

---

#### **APL 8:**

**Fitzhugh and Crickneck, Copy Wight Scribes:** 30 hp; see Appendix 3.

**Tactics:** Same as APL 6.

---

#### **APL 10:**

**Fitzhugh, Copy Wight Master:** 50 hp; see Appendix 3.

**Tactics:** At this APL, Fitzhugh is more sly. He may ask the PCs if he can be of help, then move to retrieve the Chronicle by moving through the stacks (ethereally). If he believes he is unseen he will scribe a *symbol* of sleep (APL10) or a *symbol* of stunning (APL12) on the Chronicle before calling them to its location. The first PC touching it will activate the *symbol*, unless she is taking precautions. In combat, Fitzhugh will use *mass suggestion*, stating that the PCs might want to find a good book to read while they are here. If all else fails, a Master Copy Wight can order a *greater unseen servant* (present at all times) to topple bookcases on the PCs. To do so, the servant must make a DC 15 strength check. It is considered to have a Strength of 6. Depending on the location, one toppled bookcase may drop others like dominos. PCs must make a DC 15 reflex save or take 3d6 damage and be pinned. It

requires a DC 20 strength check to free oneself from a toppled bookcase.

## **APL 12:**

---

**Fitzhugh and Crickneck, Copy Wight Masters:** 50 hp; see Appendix 3.

**Tactics:** same as APL 10.

**Development 1:** If the party was considered approachable and talked with Fitzhugh, this may not be the last they see of him (even if they killed him) because for Fitzhugh, death is just the beginning of the next chapter. When the PCs open the chronicle, a note falls out. It is written in a fine hand:

It took your hand to get me sacked;  
You might think I'd not wish you well.  
Adventure this position lacked:  
Alas, it was a job from Hell.  
  
Now freed, what can I offer you?  
No gold have I, nor sword to fight.  
But need a scribe? Call "P. Fitzhugh"  
When you require a Copy Wight.  
  
-P. Fitzhugh, *Forger Extraordinaire*

He may be of help to the party in *Encounter Eight*, making a duplicate of the Chronicle for the emissary.

If PCs retrieve the Chronicle and wish to read it, doing so requires 5 minutes. When they read it, give them *Player Handout Five*.

**Development 2:** Depending upon the duration of this encounter and their method of escape, they may be beset by the guards of Cryllor. If burglary of the Archives is discovered, the Crylloran authorities respond by setting guards to deal with the criminals. As in *Encounter 6*, Merla Hennig, constable of Cryllor, will join the third squad of guards. The response is driven by the Secretary to the Lady Regent and her special assistant, Darvis Albrect, a wizard of some ability. Determine xp and consequences for this encounter using the guidelines below:

**Clean Escape:** If the PCs obtained the Chronicle and escaped without detection, note this and award full XP for the encounter.

**Escaped but Identified:** PCs that can be identified have a warrant issued for their arrest. See the Adventure Record; the PCs gain the **Wanted** status (see the Adventure Record). Award half XP for this encounter for such PCs.

**Surrender:** Merla Hennig interrogates the PC about her actions. If the PC uses influence with Crylloran

authorities and is cooperative, she is imprisoned for 2 TU, fined half of the GP cap for the APL and released with a warning. If the PC uses no influence, double the TU penalty, and the PC is **Banished** (see the Adventure Record). In all cases, if the PC cannot afford the fine, add 6 TU to the sentence. However, award full XP – the PCs' cooler heads prevailed, and they did not resort to violence.

**Captured after Resistance:** If the PC resisted, double all penalties and TU costs listed above. Award ½ XP for the "Escaping cleanly from the Agents of Cryllor" item in the Experience Point Summary. In either case, the PCs will be **Banished** (see the Adventure Record).

**Killed a Citizen of Cryllor:** If the PC **kills** (not just injures or incapacitates) any of the Crylloran citizens (excluding the Copy Wights) and escapes, a warrant is issued against her for apprehension and execution. *This applies ONLY to the PC that dealt the killing blow.* The PC gains the **Wanted** status (see the Adventure Record). If the PC is captured, has no influence or favors to mitigate their capital crime (one of Power Rank: Noble or better; contact the Keoland Triad for details), and is not a noble of Keoland, she is summarily executed. Other PCs that were accomplices in the crime are **Banished** (see the Adventure Record).

If the PC condemned to death (or any other PCs in her party) uses influence points of at least Power Rank: Noble, she receives a stay of execution. Spending one point yields a life sentence; two points a 104 TU sentence. Each point of influence spent thereafter on the PCs behalf by any PC at the table reduces the sentence by 13 TU. Award no XP for encounters 7 and 8, or the "Escaping cleanly from the Agents of Cryllor" item in the Experience Point Summary. The PC is fined as if she was captured and resisted.

Note: If other PCs escape to Crookhollow, Pemlo may use his influence with the King to have the sentence reduced. The King's influence will reduce the sentence from death to 104 TU's; subsequent influence point expenditures may be made by the PC or his companions as noted above.

Depending on the consequences of their actions, the PC may or may not participate in *Encounter Eight*.

## **Encounter Eight: The Odd Couple**

---

While the adventurers travel from Cryllor to Crookhollow, they encounter a strange pair: an ettin and a suel man in green robes. The two are talking, looking for something or someone. The man is the

Emissary of the Green Warlock. He is a dead ringer for descriptions of Gwier Dreng (but don't all Suel mages look alike?). The ettin is named Strewth, he is the mate of an ettin named Ysl, slain by adventures in Tumbledown Delve last year (see KEO2-08, *Pemlo's Lambic*). To facilitate his traveling on Keoish roads, the Emissary (an illusionist) has rendered Strewth *invisible*. Gwier Dreng was told by a very reliable source that a party of adventurers carrying information close to his heart could be found in this area. Gwier dispatched his Emissary along with Strewth as a bodyguard to negotiate with the adventurers and obtain this information. When Strewth heard they were going to meet "adventurers" alarm bells went off in his heads. This simple-minded creature thinks any adventurers might be the ones that slew his "darlin," and he is hard-pressed to contain his rage.

The Emissary is not aware of the exact nature of the information the adventurers carry. He does know the following issues motivate Lord Dreng, and may be connected with the "information": Gwier Dreng is motivated by perceived injustices against his family, he believes himself the rightful ruler of the western counties of Keoland and that he believes his father was murdered by Ignaz Manz. If asked how the Emissary found the PCs, he tells them "a wise seer informed Lord Dreng that you might be here."

Have the PCs and the agents of the Green Warlock make Spot and Listen checks and give them the opportunity to respond appropriately. If the PCs "get the drop on the pair" and succeed at Listen checks, they will hear:

**Emissary:** "No. We are just here to talk to them. They carry information close to Lord Dreng's heart."

**Strewth (Unseen voice, unless the PCs can detect invisibility):** "I tink dey're da ones dat killed 'er. Oh my poor darlin! When I find 'em, I'll kill 'em."

**Emissary:** "Calm down, Strewth. It is extremely unlikely that they are the ones. We will just talk to them ..."

The Emissary and Strewth will not attack the PCs at a distance. If the two groups close and parley, read the following:

On the road, fifty yards from you, a man can be seen. He is dressed in fine green robed trimmed in scarlet. His complexion is fair, hair blond, eyes blue. His manner is haughty, yet refined. The man addresses you, "Hail, travellers! I come as an Emissary from Gwier

Dreng. Lord Dreng has informed me that you hold information that he seeks."

A short distance away, PCs can spot the Emissary's horse (DC 10).

---

### APL 2 (EL 3):

---

Strewth, two headed ogre: 29 hp; see *Monster Manual* p. 199. (Identical to a standard ogre in all respects except appearance)

---

### APL 4 (EL 6):

---

Strewth the Ettin: 65 hp; see *Monster Manual* p.107.

---

### APL 6 (EL 9):

---

Strewth the Ettin, Bbn2/Ftr1: 112 hp; see *Appendix One*.

---

### APL 8 (EL 11):

---

Strewth the Ettin, Bbn2/Ftr1/Rog2: 126 hp; see *Appendix One*.

---

### APL 10 (EL 13):

---

Strewth the Ettin, Bbn2/Ftr2/Rog3: 159 hp; see *Appendix One*.

---

### APL 12 (EL 15):

---

Strewth the Ettin, Bbn2/Ftr2/Rog5: 175 hp; see *Appendix One*.

Give the PCs three rounds to interact with the emissary, and then read the following. Alternatively, the ettin will attack if a PC reveals the knowledge of his presence.

Appearing out of nowhere is a two-headed giant, its horrible faces contorted with ill-suppressed rage. "Dere dem I tell ya!" The Emissary tries to calm the giant, but its rage is unquenchable. "Murderers!" it's heads bellow in four tongues. "Ya killed my lil' darlin!" The giant swats aside the Emissary as he charges you.

**Tactics:** The Emissary is unconscious lying on the ground. He will not wake for 10 minutes unless Strewth or the PCs wake him. Strewth will rage (if able) and rush into combat. The ettin will be adjacent to wherever the emissary fell. Depending on how quickly (or even if) the PCs closed the gap with the emissary, Strewth may have the adventurers within arm's reach, or he may have to charge to engage them.

### Development:

Gwier Dreng sent out his Emissary not only to obtain information from these adventurers, but to communicate with the agents preparing the way for his

army. On his horse can be found a saddlebag containing letters to his lieutenants (two examples can be found in Player Handout 6) and a saddlebag containing gold (payment for the adventurers in exchange for the information). The letters contain a great deal of information about the Green Warlock's army and orders for commanders. This could be precisely what the Guardians of the Highlands need to prevail.

If the PCs can duplicate the documents or copy the information without disturbing the seals, the forces of the Good Hills gain great advantage against the encroaching army of the Green Warlock. This can easily be done if the PCs summon Fitzhugh by calling his name (see **Special Encounter: Copy Wight**, below).

If the documents are noticeably tampered with and/or the Emissary is detained, Gwier Dreng is alerted and no advantage is gained. These consequences will affect the Interactive: Crookhollow Blues at UNY-CON 2003.

When the Emissary awakes, he surveys the battlefield and comments to the PCs, "Alas, poor Strewth. I should have seen it coming. Anger management always seems to be a problem with the barbarians. [looks at the PCs] Dear, dear. He really had it is for you. I hope Strewth's uncle doesn't find out about this. His uncle is the REALLY nasty one."

By this time, the PCs should have figured out that reports of Gwier Dreng's death were greatly exaggerated and that Gwier Dreng and the Green Warlock are one and the same. They may, however, conclude that the Emissary IS the Green Warlock. Whatever they do, the Emissary will not attack. Play the Emissary as suspicious if PCs act strange or guilty. He is loathe to disclose more information than necessary about his master and will deny that he is this Green Warlock (he denies even knowing the name, but he's lying) and that there is a warrant out for his arrest. He is a simple messenger. If pressed, the emissary casts Lord Dreng's actions to this point in the most positive light and insinuates that the Crylloran authorities have forced his hand.

He will proceed to negotiate with willing PCs over their information. In exchange for the information he will offer each PC involved a reward (25 gp x APL now and a like amount will delivered to them within a week). If the PCs use call of Fitzhugh, one copy of the Chronicle can still be delivered to the Guardians of the Highlands. There are several possible outcomes of this encounter:

**The PCs apprehend the Emissary:**

He gives no information to the party. Award no experience. He carries some coin (25 gp x APL per PC) on his horse.

**The PCs give the information contained in the Chronicle or a facsimile thereof:**

He concludes the abovementioned deal. Each PC involved receives the favor of Gwier Dreng.

**The PCs give the emissary Count Dreng's medallion of office:**

The emissary concludes the deal as above, but, when a messenger delivers the second payment, he also carries a set of rosewood boxes for the PCs. They are laden with gems and jewels – an amount equal to (125 x APL) gp. **BE SURE TO DEDUCT THIS REWARD FROM THE ADVENTURE RECORD IF THE REWARD WENT UNEARNED BY THE PCS.** To calculate how many gp an individual player loses for this missed opportunity, divide the above amount by six and subtract that from the listed maximum gp earned for the adventure.

## **Special: Calling on Fitzhugh**

This encounter is triggered if the PCs summon Fitzhugh by calling his name.

For a moment it is quiet, then a figure materializes out of the air. It is the spirit librarian from the archives. He seems to stand taller now and appear somewhat less nervous. It seems he couldn't be happier about the loss of his position in Cryllor. "Thank you for releasing me from that dreary Archive. Nothing there but fodder for accountants. Anyway, I'm off to Greyhawk. Positions are opening all the time, they say. Wait a moment! You didn't call for conversation, did you? Do you have need of my skills?"

Fitzhugh will speak with the PCs as long as they wish. They may ask him what he knows of the Chronicle, to which he answers, "It is a record, sometimes a personal record, of the ruler of Cryllor. It's probably the juiciest material in the Archives. For the most part, the Chronicles document diplomatic meetings, trade agreements and tax levies, but here and there you find journal entries, family arguments and intrigues. Quite interesting. Some entries in the latest volume were, how do you say it? Steamy!"

He is able to reproduce any documents the PCs present down to fine detail, forging even wax seals. When no longer needed he thanks the PCs again and vanishes.

*Fitzhugh cannot be summoned once the PCs have completed the module.* He's employed in the Library of Greyhawk at that point.

## Conclusion: Return to Crookhollow

---

Pemlo and Padder Slipstone celebrate the PCs return with or without the Chronicle, but they are particularly interested in any information regarding the Green Warlock's army. Pemlo recognizes Gwier Dreng's name and indicates that he remembers the man, but says no more at this time. As the heroes recount their tales laughter can be heard outside the door of the Roc's Feather. The voice is rich and vaguely familiar. When a character opens the door she finds no one there, only a single clear halfling footprint in the dirt.

Regardless of their success, Pemlo grants 5 shares of stock to each of the adventurers. If a PC hadn't purchased it in KEO2-08, Pemlo offers the PCs his skiprock. If they returned with information from the Emissary, Pemlo uses influence with the King to reduce the penalties incurred by PCs in Cryllor. During future adventures in the Good Hills, PCs are considered safe from the Crylloran authorities.

The Guardians make a number of items available to the PCs (the *Longtooth*, *Halfling's Exit* and Quick-Escape Armor) as well as offer their goodwill.

### The End

## Experience Point Summary

---

### Encounter Three

Surviving the flooding passage:

APL2 60 xp; APL4 120 xp; APL6 180 xp; APL8 240 xp; APL10 300 xp; APL12 360 xp.

Defeating the rats:

APL2 30 xp; APL4 30 xp; APL6 30 xp; APL8 90 xp; APL10 90 xp; APL12 90 xp.

### Encounter Four

Defeating/laying to rest the ghost and gaining the page of the Chronicle:

APL2 120 xp; APL4 180 xp; APL6 240 xp; APL8 300 xp; APL10 360 xp; APL12 420 xp.

### Encounter Seven

Defeating the Copy Wight(s):

APL2 90 xp; APL4 150 xp; APL6 180 xp; APL8 240 xp; APL10 270 xp; APL12 330 xp.

Escaping cleanly from the Agents of Cryllor\*:

APL2 90 xp; APL4 180 xp; APL6 240 xp; APL8 270 xp; APL10 360 xp; APL12 420 xp.

Note modifications to the xp award in the **Developments** section of **Encounter 8**.

### Encounter Eight

Defeating Strewth:

APL 2 90 xp; APL 4 210 xp; APL 6 270 xp; APL 8 330 xp; APL 10 390 xp; APL 12 450 xp.

### Story Award

Copying the Emissary's missives without alerting him:

APL2 45 xp; APL4 65 xp; APL6 90 xp; APL8 110 xp; APL10 135 xp; APL12 155 xp.

### Total possible experience:

APL2 450 xp; APL4 675 xp; APL6 900 xp; APL8 1,125 xp; APL10 1,350 xp; APL12 1,575 xp.

## Treasure Summary

---

During an adventure, characters encounter treasure, usually finding it in the possession of their foes. Every encounter that features treasure has a "treasure" section within the encounter description, giving information about the loot, coins, and magic items that make up the encounter's treasure.

The loot total is the number of gold pieces each character gains if the foes are plundered of all their earthly possessions. Looting the bodies takes at least 10 minutes per every 5 enemies, and if the characters cannot take the time to loot the bodies, they do not gain this gold. If you feel it is reasonable that characters can go back to loot the bodies, and those bodies are there (i.e., not carted off by dungeon scavengers, removed from the scene by the local watch, and so on), characters may return to retrieve loot. If the characters do not loot the body, the gold piece value for the loot is subtracted from the encounter totals given below.

The coin total is the number of gold pieces each character gains if they take the coin available. A normal adventuring party can usually gather this wealth in a round or so. If for some reason, they pass up this treasure, the coin total is subtracted from the encounter totals given below.

Next, the magic items are listed. Magic item treasure is the hardest to adjudicate, because they are varied and

because characters may want to use them during the adventure. Many times characters must cast *identify*, *analyze dweomer* or similar spell to determine what the item does and how to activate it. Other times they may attempt to use the item blindly. If the magic item is consumable (a potion, scroll, magic bolts, etc.) and the item is used before the end of the adventure, its total is subtracted from the adventure totals below.

Once you have subtracted the value for unclaimed treasure from each encounter add it up and that is the number of gold pieces a characters total and coin value increase at the end of the adventure. Write the total in the GP Gained field of the adventure certificate. Because this is a Regional scenario, characters may spend additional Time Units to practice professions or create items immediately after the adventure so this total may be modified by other circumstances.

L = Looted gear from enemy; C = Coin, Gems, Jewelry, and other valuables; M = Magic Items.

L: Looted gear from enemy

C: Coin, Gems, Jewelry, and other valuables

M: Magic Items (sell value)

#### Encounter Four

APL 2: L: 0 gp; C: 333 gp; M: 125 gp

APL 4: L: 0 gp; C: 500 gp; M: 125 gp

APL 6: L: 0 gp; C: 667 gp; M: 125 gp

APL 8: L: 0 gp; C: 833 gp; M: 125 gp

APL 10: L: 0 gp; C: 1000 gp; M: 125 gp

APL 12: L: 0 gp; C: 1000 gp; M: 292 gp

#### Encounter Eight:

APL 2: L: 4 gp; C: 42 gp; M: 0 gp

APL 4: L: 4 gp; C: 83 gp; M: 0 gp

APL 6: L: 4 gp; C: 125 gp; M: 193 gp

APL 8: L: 29 gp; C: 167 gp; M: 193 gp

APL 10: L: 29 gp; C: 208 gp; M: 193 gp

APL 12: L: 3 gp; C: 250 gp; M: 386 gp

#### Total Possible Treasure

APL 2: L: 4 gp; C: 375 gp; M: 125 gp - Total: 504 gp

APL 4: L: 4 gp; C: 583 gp; M: 125 gp - Total: 712 gp

APL 6: L: 4 gp; C: 792 gp; M: 318 gp - Total: 1114 gp

APL 8: L: 29 gp; C: 1000 gp; M: 318 gp - Total: 1347 gp

APL 10: L: 29 gp; C: 1208 gp; M: 318 gp - Total: 1555 gp

APL 12: L: 3 gp; C: 1250 gp; M: 678 gp - Total: 1931 gp

#### Special

**Shares in A Pendant for Drink:** The PC has purchased and/or been gifted with shares in A Pendant for Drink. The player may sell or hold these shares; the price varies with time. These and any other shares may be sold anytime during this adventure for 75 gp apiece. Note the transaction on the lines below. Shares may only be sold in Keoland scenarios in which such a sale is specifically allowed.

\_\_\_\_\_ Prior held shares PLUS

\_\_\_\_\_ Shares bought PLUS

\_\_\_\_\_ Shares given to PC by Pemlo MINUS

\_\_\_\_\_ Shares bought (at 75 gp each) EQUALS

\_\_\_\_\_ Final shares remaining

**Banished:** You have been banished from the County of Cryllor. This PC may not take part in any adventure that takes place in the County of Cryllor. During adventures that take place partially in Cryllor you may not participate in the parts that occur in Cryllor.

**Wanted:** You have evaded the authorities of Cryllor for now. You are now considered Hunted in Keoland. There is a reward for your capture – Dead or Alive.

**Longtooth:** This weapon is highly prized by wee folk (gnomes and halflings) that journey out in search of adventure. As a free action, the wielder may command the *Longtooth* to transform into a Small dagger, short sword or longsword. In all forms, it retains a +1 bonus. (Frequency: Regional) (Caster Level 5<sup>th</sup>, *Prerequisites:* Craft Magical Arms and Armor, *enlarge person*, *reduce person*; *Market Price:* 5,315 gp)

**Quick-Escape Armor:** (from the *Arms and Equipment Guide*) This armor uses special buckles, straps and releases so it can be removed in mere moments. As a standard action, the wearer pulls and twists on a special lock, located on the shield-side hip, which causes the armor to fall away. Each lock is unique in operation, making it difficult for anyone other than the owner to undo, especially in the middle of a battle. A Disable Device check (DC 30) is required for someone other than the wearer to release the armor in combat. If the attempt is made while the wearer is not in combat, then the DC is 15. The quick-escape extra must be included

during the creation of the armor, which must be of at least masterwork quality. It takes twice as long as normal to put on quick-escape armor. (Frequency: Regional) (*Market Price*: as base armor +300 gp)

**Pemlo's Skiprock:** This halfling skiprock (see *Sword and Fist*) acts as a +1 *returning* weapon. Once per week, the wielder of Pemlo's skiprock can cast *cat's grace* (3<sup>rd</sup> level caster) on himself. This may only be done within ten rounds of hitting and damaging an opponent with the skiprock. A PC may only own one Pemlo's Skiprock; its appearance here represents another offer by Pemlo to offer it for sale to a PC. (Frequency: Regional) (*Caster Level*: 7<sup>th</sup>; *Prerequisites*: Craft Magic Arms and Armor, *telekinesis*, *cat's grace*; *Market Price*: 8000 gp)

**Goodwill of the Guardians:** Your recovery of the Chronicle of Cryllor is deeply appreciated by the Guardians. They offer to share with you some of their "tricks of the trade." A PC may expend this item (mark an X through this item on the Adventure Record) to gain one-time access to any single feat from the *Song and Silence* book.

#### **Ole '68:**

This special brew of Pemlo's Lambic grants a +1 morale bonus on saving throws against charm and fear effects and a +1 morale bonus on attack and weapon damage rolls. The effect lasts for 10 minutes. The bottle has three draughts left. Place an X through each of the circles as the draughts are consumed: O O O

#### **Mark of Brandobaris:**

The PC has a dagger-shaped silver-black tattoo imprinted on their forearm (even chance for either arm). This mark has two effects. First, this PC is under the permanent effect of a *Reduce Person* spell. An *Atonement* spell cast by a cleric of Brandobaris may remove the effect. (NOTE: If a PC cleric does this for this PC, the player of the PC cleric MUST contact the Keoland Triad for confirmation). Otherwise a *Limited Wish*, *Wish* or *Miracle* spell will remove the mark. If/when the mark is removed, place an X through this AR item.

## **Items for the Adventure Record**

### **Item Access**

---

APL 2:

*Longtooth*

Quick-Escape Armor

Pemlo's Skiprock

APL 4:

APL 2 Items

*Brooch of Shielding*

APL 6:

APL 2 & 4 Items

Large *morningstar* +1

Large heavy pick

Large hide armor

APL 8:

APL 2, 4, & 6 Items

Masterwork large heavy pick

APL 10:

APL 2, 4, 6 & 8 Items

APL 12:

APL 2, 4, 6, 8 & 10 Items

*Cloak of Charisma* +2

Large heavy pick +1

## DM Aid One: Map of Baelfract Keep Drainage System

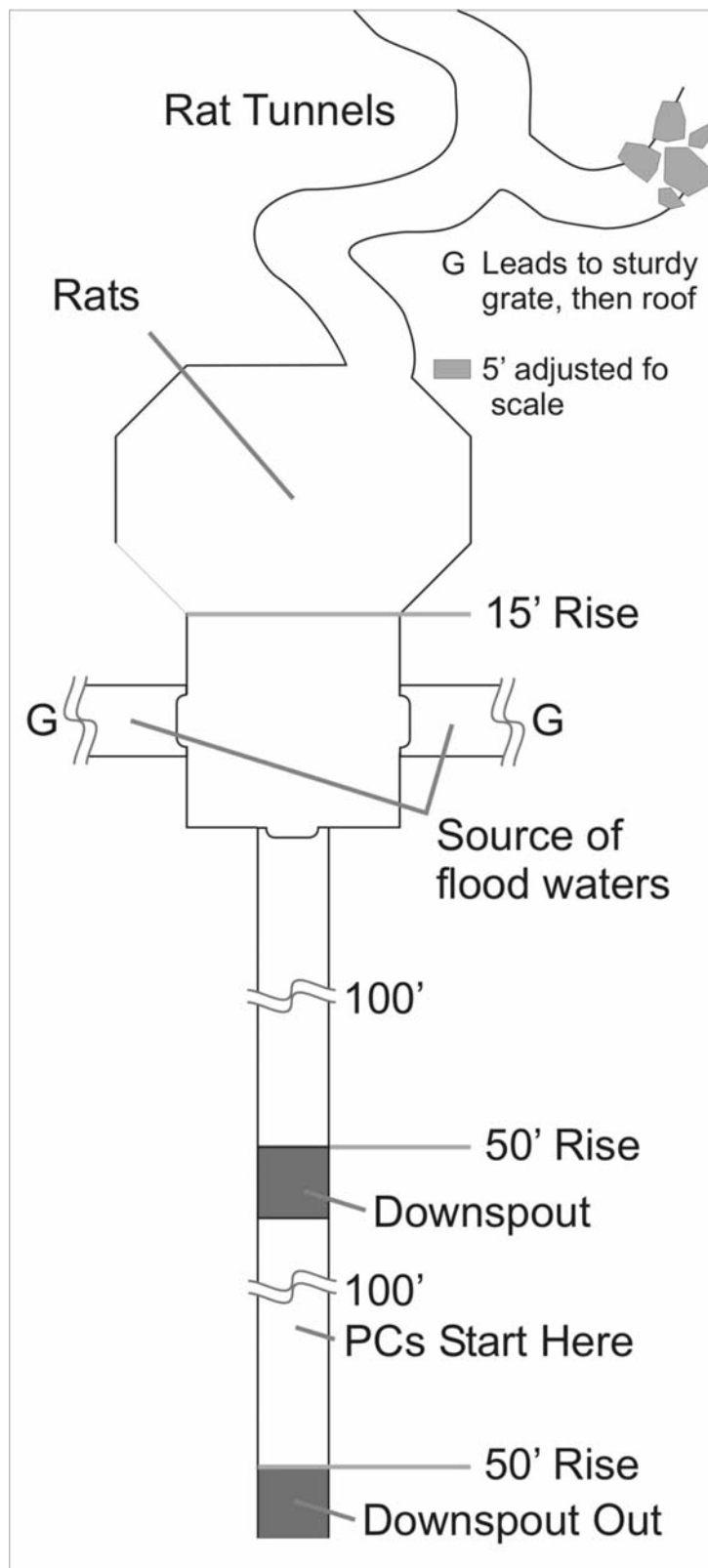



## DM Aid Two: Count Dreng's Inner Sanctum

---

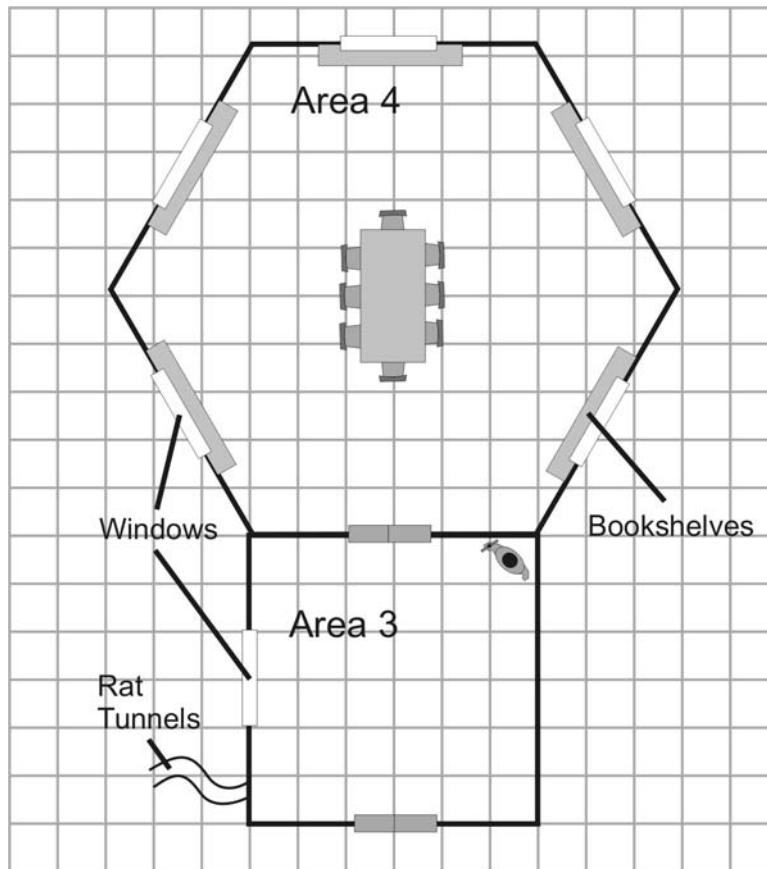

## DM Aid Three: The Archives

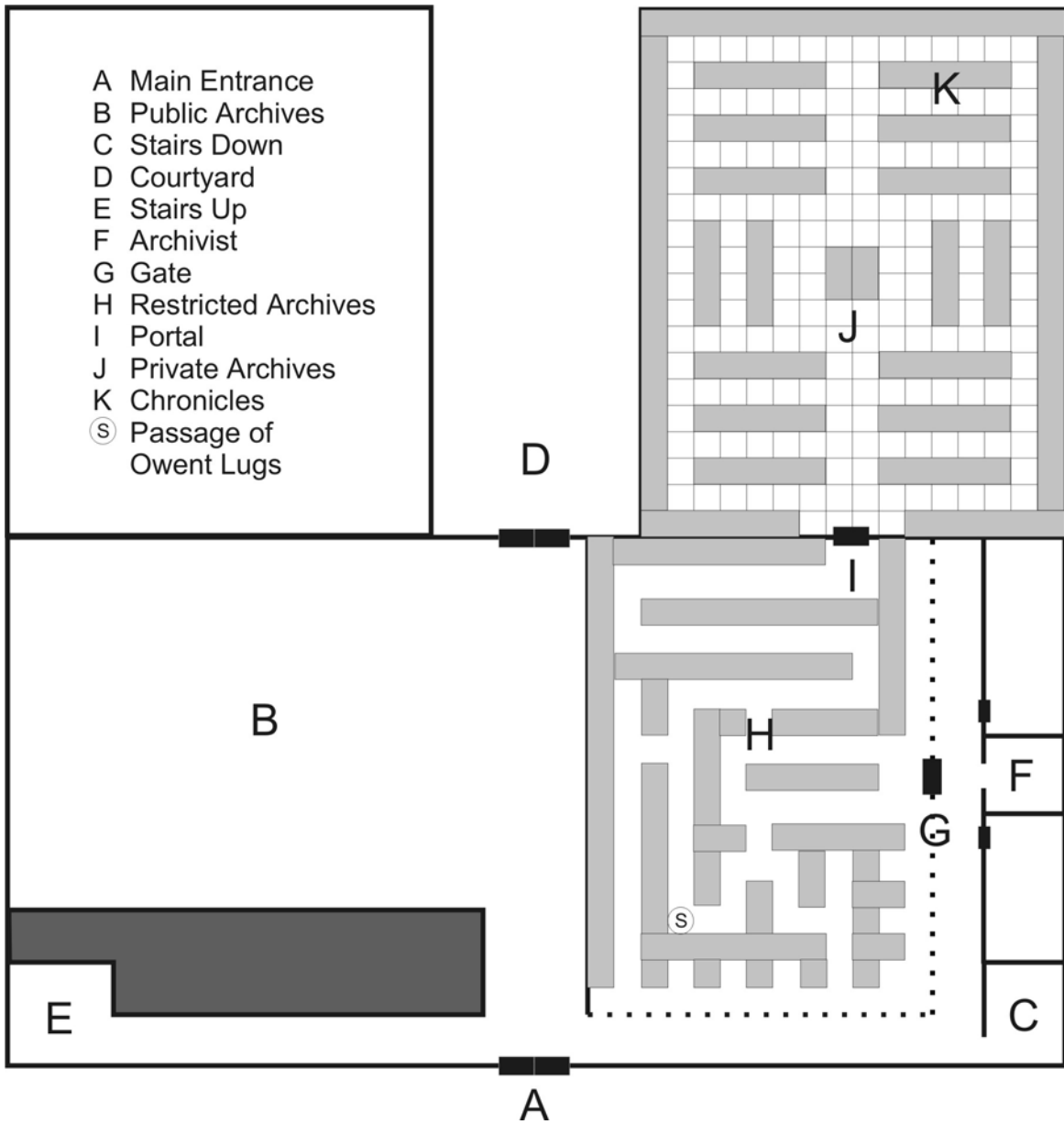

# Appendix One: Stat Blocks by APL

## All APLs

---

### Encounter 6 & 8:

**Crylloran Guardsman, Male Human War 2:** Medium Humanoid; HD 2d8+4; hp 18; Init +1; Spd 30' (6 squares); AC 17 (Flatfooted 16, Touch 11); Atk +4 melee (1d8+2, longsword) or +3 missile (1d8, light crossbow); AL LN; SV Fort + 5, Ref + 1, Will + 0; STR 14, DEX 12, CON 14, INT 10, WIS 10, CHA 10.

Skills & Feats: Gather Information +1, Intimidate +4, Listen +2, Ride +6, Spot +4. Alertness, Combat Reflexes.

Possessions: Light crossbow, 20 bolts, longsword, chain shirt, heavy steel shield.

**Merla Hennig:** Female Human Rog4/Wiz2: Medium Humanoid; HD 4d6+2d4; hp 24; Init + 7; Spd 30' (6 squares); AC 18 (Flatfooted 15, Touch 14); Atk +6 melee (1d6+1, rapier) and +3 melee (1d4, dagger) or +7 missile (1d8, longbow); SA Sneak Attack +2d6; SQ Evasion, Trapfinding, Uncanny Dodge; AL LN; SV Fort + 1, Ref + 7, Will + 5; STR 10, DEX 16, CON 10, INT 15, WIS 12, CHA 12.

Skills & Feats: Concentration +4, Decipher Script +4, Diplomacy +3, Disable Device +5, Disguise +3, Escape Artist +4, Gather Information +5, Hide +9, Jump +2, Knowledge: local (Metaregion One) +9; Listen +6, Move Silently +9, Open Lock +7, Ride +4, Search +5, Sense Motive +3, Spot +5, Tumble +12, Use Magic Device +5, Wilderness Lore + 2. Ambidexterity, Expertise, Improved Initiative, Two-Weapon Fighting, Weapon Finesse.

Spells Prepared (4/3; DC 12 + spell level): 0 - *Detect Magic, Detect Poison, Light, Read Magic, Resistance*; 1st - *Change Self, Longstrider, Shield, True Strike*.

Possessions: +1 *Keen rapier*, masterwork dagger, longbow, mithral shirt, masterwork thieves' tools, *Ring of Protection +1*; *Scroll of Whispering Wind, Scroll of Web, Scroll of Resist Elements, Scroll of Locate Object, Scroll of Mirror Image, Scroll of Knock, Scroll of Invisibility*.

## APL 2:

---

### Encounter 4:

**Count Dreng's Ghost, Male Ghost Ari3:** CR 4; Medium Undead; HD 3d12; hp 29; Init +5; Spd fly 30 (6 squares; perfect); AC 16 (Flatfooted 15, Touch 16); Atk +3 melee (1d3, touch, only against ethereal foes); SA: Malevolence (Will, DC 20), Manifestation; SQ: Rejuvenation; +4 Turn Resistance; AL N; SV Fort +1, Ref +2, Will +4; STR 10, DEX 12, CON -, INT 13, WIS 12, CHA 20.

Skills & Feats: Bluff +5, Hide +8, Diplomacy +5, Knowledge: arcana +3, Knowledge: history +3, Knowledge: local (Metaregion One) +3, Knowledge: nobility +3, Knowledge: religion +3, Listen +15, Perform +5, Ride +3, Search +8, Sense Motive +3, Spot +15, Swim +2. Improved Initiative, Toughness, Weapon Focus: touch.

Languages: Common, Ancient Sueloise, Keoish, Draconic.

Possessions: Assorted jewelry (2000 gp)

## APL 4:

---

### Encounter 3:

**Dire Rats (Advanced, 2HD):** Small Animal; HD 2d8+2; hp 11; Init +3; Spd 40 ft (8 squares), climb 20 ft (4 squares); AC 15 (Flatfooted 12, Touch 14); Atk bite +5 melee (1d4 + disease [filth fever]); SA Disease; SQ Low-light vision, scent; AL N; SV Fort +4, Ref +6, Will +4; STR 10, DEX 17, CON 12, INT 1, WIS 12, CHA 4.

Skills & Feats: Climb +11, Hide +8, Listen +4, Move Silently +4, Spot +5, Swim +11. Alertness, Weapon Finesse.

### Encounter 4:

**Count Dreng's Ghost, Male Ghost Ari3/Sor2:** CR 6; Medium Undead; HD 5d12; hp 41; Init +5; Spd: fly 30' (6 squares; perfect); AC 20\* (Flatfooted 15, Touch 16); Atk +4 melee touch (1d6); SA: Corrupting Touch,

Malevolence (Will DC 20), Manifestation; SQ: Rejuvenation; +4 Turn Resistance; AL N; SV Fort +1, Ref +2, Will +7; STR 10, DEX 12, CON -, INT 13, WIS 12, CHA 21.

Skills & Feats: Bluff +5, Hide +8, Concentration +4, Diplomacy +5, Knowledge: arcana +3, Knowledge: history +3, Knowledge: local (Metaregion One)+3, Knowledge: nobility +3, Knowledge: religion +3, Listen +16, Perform +5, Ride +3, Sense Motive +3, Spot +16, Swim +2. Improved Initiative, Toughness, Weapon Focus: touch.

Languages: Common, Ancient Sueloise, Keoish, Draconic.

Spells Known (Sor 6/5; DC 15 + spell level): 0 -- *Dancing Lights*, *Detect Magic*, *Mage Hand*, *Ray of Frost*, *Read Magic*; 1st -- *Mage Armor*, *Ray of Enfeeblement*.

Possessions: *Brooch of shielding* (50 hp remaining), assorted jewelry (3000 gp).

\* Included pre-cast *mage armor* spell.

---

## APL 6:

### Encounter 3:

**Dire Rats (Advanced, 3HD):** Small Animal; HD 3d8+3; hp 16; Init +3; Spd 40 ft (8 squares), climb 20 ft (4 squares); AC 15 (Flatfooted 12, Touch 14); Atk bite +6 melee (1d4 + disease [filth fever]); SA Disease; SQ Low-light vision, scent; AL N; SV Fort +4, Ref +6, Will +4; STR 10, DEX 17, CON 12, INT 1, WIS 12, CHA 4.

Skills & Feats: Climb +11, Hide +8, Listen +5, Move Silently +4, Spot +5, Swim +11. Alertness, Weapon Finesse.

### Encounter 4:

**Count Dreng's Ghost, Male Ghost Ari3/Sor4:** CR 8; Medium Undead; HD 7d12; hp 53; Init +5; Spd: fly 30' (6 squares; perfect); AC 20\* (Flatfooted 15, Touch 16); Atk +4 melee touch (1d6); SA: Corrupting Touch, Malevolence (Will DC 20), Manifestation; SQ: Rejuvenation; +4 Turn Resistance; AL N; SV Fort +2, Ref +5, Will +8; STR 10, DEX 12, CON -, INT 13, WIS 12, CHA 21.

Skills & Feats: Bluff +5, Concentration +8, Diplomacy +5, Hide +8, Knowledge: arcane +3, Knowledge: history +3, Knowledge: local (Metaregion One) +3, Knowledge: nobility +3, Knowledge: religion +3, Listen +17, Perform +5, Ride +3, Sense Motive +3, Spot +17, Swim +2. Improved Initiative, Lightning Reflexes, Toughness, Weapon Focus: touch.

Languages: Common, Ancient Sueloise, Keoish, Draconic.

Spells Known (6/7/4; DC 15 + spell level): 0 -- *Dancing Lights*, *Daze*, *Detect Magic*, *Mage Hand*, *Ray of Frost*, *Read Magic*; 1st -- *Mage Armor*, *Magic Missile*, *Ray of Enfeeblement*; 2nd -- *Blindness/Deafness*.

Possessions: *Brooch of shielding* (50 hp remaining), assorted jewelry (4000 gp).

\* Included pre-cast *mage armor* spell.

### Encounter 8:

**Strewth the Ettin, Bbn2/Ftr1:** Large Giant; HD 10d8+1d10+2d12+39; hp 112; Init +6; Spd 40 ft; AC 21 (Flatfooted 19, Touch 11); Atk +19/+14 melee (2d6+10, 19-20/x2, *large morningstar* +1) and +18/+13 melee (1d8+9, large heavy pick); Face/Reach 10'/10'; SQ: Darkvision 90' Rage\*, Uncanny Dodge; SV Fort +15, Ref +5, Will +5; AL NE; Str 28, Dex 14, Con 17, Int 8, Wis 10, Cha 8.

Skills & Feats: Listen +10, Search +2, Spot +8, Survival +4. Alertness, Combat Reflexes, Improved Critical (*morningstar*), Improved Initiative, Iron Will, Power Attack.

Possessions: *Large morningstar* +1, large hide armor, dead rat.

\* When raging, Strewth gains the following: Str +4 (and +2 to hit and damage), Con +4 (and +26 hp), and a +4 morale bonus to Will saving throws.

## APL 8:

---

### Encounter 3:

**Dire Rats (Advanced, 6HD):** Medium Animal; HD 6d8+12; hp 39; Init +3; Spd 40 ft (8 squares), climb 20 ft (4 squares); AC 14 (Flatfooted 11, Touch 13); Atk bite +10 melee (1d4+2 and disease [slimy doom]); SA Disease; SQ Low-light vision, scent; AL N; SV Fort +7, Ref +8, Will +5; STR 14, DEX 16, CON 14, INT 1, WIS 12, CHA 4.

Skills & Feats: Climb +13, Hide +7, Listen +5, Move Silently +4, Spot +5, Swim +13. Alertness, Weapon Finesse, Weapon Focus (Bite).

### Encounter 4:

**Count Dreng's Ghost, Male Ghost Ari3/Sor6:** CR 10; Medium Undead; HD 9d12; hp 65; Init +5; Spd: fly 30' (6 squares; perfect); AC 21\* (Flatfooted 16, Touch 17); Atk +6 melee touch (1d6); SA Corrupting Touch, Malevolence (Will DC 21), Manifestation; SQ: Rejuvenation; +4 Turn Resistance; AL N; SV Fort +3, Ref +6, Will +9; STR 10, DEX 12, CON 8, INT 13, WIS 12, CHA 22.

Skills & Feats: Bluff +5, Concentration +11, Diplomacy +5, Hide +8, Knowledge (arcana) +3, Knowledge (History) +3, Knowledge (Local) +3, Knowledge (Nobility) +3, Knowledge (Politics) +3, Listen +19, Perform +5, Ride +3, Sense Motive +3, Speak Language +2, Spot +18, Swim +3. Improved Initiative, Lightning Reflexes, Silent Spell, Toughness, Weapon Focus: touch.

Languages: Common, Ancient Sueloise, Keoish, Draconic.

Spells Known (6/7/6/4; DC 16 + spell level): 0 -- *Dancing Lights*, *Daze*, *Detect Magic*, *Mage Hand*, *Ray of Frost*, *Read Magic*, *Resistance*; 1st -- *Longstrider*, *Mage Armor*, *Magic Missile*, *Ray of Enfeeblement*; 2nd -- *Blindness/Deafness*, *Web*; 3rd -- *Vampiric Touch*.

Possessions: *Brooch of shielding* (50 hp remaining), assorted jewelry (5000 gp).

\* Included pre-cast *mage armor* spell.

### Encounter 8:

**Strewh the Ettin, Bbn2/Ftr1/Rog2:** Large Giant; HD 2d6+10d8+1d10+2d12+45; hp 126; Init +6; Spd 40 ft; AC 21 (Flatfooted 19, Touch 11); Atk +21/+16 melee (2d6+10, 19-20/×2, *large morningstar +1*) and +20/+15 melee (1d8+9, large masterwork heavy pick); Face/Reach 10'/10'; SA: Sneak Attack (+1d6); SQ: Darkvision 90', Evasion, Rage\*, Trapfinding, Uncanny Dodge; SV Fort +15, Ref +8, Will +5; AL NE; Str 28, Dex 14, Con 17, Int 8, Wis 10, Cha 8.

Skills & Feats: Listen +13, Search +2, Spot +11, Survival +4, Tumble +7. Alertness, Combat Reflexes, Improved Critical (Morningstar), Improved Initiative, Iron Will, Power Attack, Weapon Focus (morningstar).

Possessions: *Large morningstar +1*, large hide armor, large masterwork heavy pick, dead rat.

\* When raging, Strewh gains the following: Str +4 (and +2 to hit and damage), Con +4 (and +30 hp), and a +4 morale bonus to Will saving throws.

## APL 10:

---

### Encounter 3:

**Dire Rats (Advanced, 6HD):** Medium Animal; HD 6d8+12; hp 39; Init +3; Spd 40 ft (8 squares), climb 20 ft (4 squares); AC 14 (Flatfooted 11, Touch 13); Atk bite +10 melee (1d4+2 and disease [blinding sickness]); SA Disease; SQ Low-light vision, scent; AL N; SV Fort +7, Ref +8, Will +5; STR 14, DEX 16, CON 14, INT 1, WIS 12, CHA 4.

Skills & Feats: Climb +13, Hide +7, Listen +5, Move Silently +4, Spot +5, Swim +13. Alertness, Weapon Finesse, Weapon Focus (Bite).

### Encounter 4:

**Count Dreng's Ghost, Male Ghost Ari3/Sor8:** CR 12; Medium Undead; HD 11d12; hp 77; Init +5; Spd fly 30' (6 squares; perfect); AC 21\* (Flatfooted 16, Touch 17); Atk +7 melee touch (1d6); SA Corrupting Touch, Frightful Moan (Will DC 21 or panicked 2d4 rounds), Malevolence (Will DC 21), Manifestation; SQ: Rejuvenation; +4 Turn Resistance; AL N; SV Fort +3, Ref +6, Will +10; STR 10, DEX 12, CON 8, INT 13, WIS 12, CHA 22.

Skills & Feats: Bluff +6, Concentration +14, Diplomacy +6, Hide +8, Knowledge: arcane +3, Knowledge: history +3, Knowledge: local (Metaregion One) +3, Knowledge: nobility +3, Knowledge: religion +3, Listen +20, Perform +6, Ride +3, Search +8, Sense Motive +3, Spot +20, Swim +2. Improved Initiative, Lightning Reflexes, Silent Spell, Toughness, Weapon Focus: touch.

Languages: Common, Ancient Sueloise, Keoish, Draconic.

Spells Known (6/7/7/6/4; DC 16 + spell level): 0 -- *Dancing Lights, Daze, Detect Magic, Flare, Mage Hand, Ray of Frost, Read Magic, Resistance*; 1st -- *Longstrider, Mage Armor, Magic Missile, Ray of Enfeeblement, True Strike*; 2nd -- *Blindness/Deafness, Invisibility, Web*; 3rd -- *Dispel Magic, Vampiric Touch*; 4th -- *Bestow Curse*.

Possessions: *Brooch of shielding* (50 hp remaining), assorted jewelry (6000 gp).

\* Included pre-cast *mage armor* spell.

### Encounter 8:

**Strewh the Ettin, Bbn2/Ftr2/Rog3:** Large Giant; HD 3d6+10d8+2d10+2d12+68; hp 159; Init +6; Spd 40 ft; AC 21 (Flatfooted 19, Touch 11); Atk +23/+18/+13 melee (2d6+10, *large morningstar* +1) and +22/+17/+12 melee (1d8+9, 19-20/x4, large masterwork heavy pick); Face/Reach 10'/10'; SA: Sneak Attack (2d6); SQ: Darkvision 90', Evasion, Rage, Trapfinding; Uncanny Dodge; SV Fort +18, Ref +8, Will +6; AL NE; Str 28, Dex 14, Con 18, Int 8, Wis 10, Cha 8.

Skills & Feats: Intimidate +1, Listen +16, Search +2, Spot +11, Survival +4, Tumble +11. Alertness, Blind-Fight, Combat Reflexes, Improved Critical (heavy pick), Improved Initiative, Iron Will, Power Attack, Weapon Focus (morningstar).

Possessions: *Large morningstar* +1, large hide armor, large masterwork heavy pick, dead rat.

\* When raging, Strewh gains the following: Str +4 (and +2 to hit and damage), Con +4 (and +34 hp), and a +4 morale bonus to Will saving throws.

## APL 12:

---

### Encounter 3:

**Dire Rats (Advanced, 6HD):** Medium Animal; HD 6d8+12; hp 39; Init +3; Spd 40 ft (8 squares), climb 20 ft (4 squares); AC 14 (Flatfooted 11, Touch 13); Atk bite +10 melee (1d4+2 and disease [demon fever]); SA Disease; SQ Low-light vision, scent; AL N; SV Fort +7, Ref +8, Will +5; STR 14, DEX 16, CON 14, INT 1, WIS 12, CHA 4.

Skills & Feats: Climb +13, Hide +7, Listen +5, Move Silently +4, Spot +5, Swim +13. Alertness, Weapon Finesse, Weapon Focus (Bite).

### Encounter 4:

**Count Dreng's Ghost, Male Ghost Ari3/Sor8:** CR 12; Medium Undead; HD 14d12; hp 95; Init +5; Spd fly 30' (6 squares; perfect); AC 23\* (Flatfooted 18, Touch 19); Atk +7/+2 melee touch (1d6); SA Corrupting Touch, Frightful Moan (Will DC 23 or panicked 2d4 rounds), Malevolence (Will DC 23), Manifestation; SQ: Rejuvenation; +4 Turn Resistance; AL N; SV Fort +6, Ref +7, Will +11; STR 10, DEX 12, CON 8, INT 13, WIS 12, CHA 25.

Skills & Feats: Bluff +7, Concentration +16, Diplomacy +7, Hide +9, Knowledge: arcana +3, Knowledge: history +3, Knowledge: local (Metaregion One) +3, Knowledge: nobility +3, Knowledge: religion +3, Listen +22, Perform +7, Ride +3, Search +9, Sense Motive +3, Spot +22, Swim +2. Great Fortitude, Improved Initiative, Lightning Reflexes, Silent Spell, Toughness, Weapon Focus: touch.

Spells Known (6/8/8/7/7/5; DC 17 + spell level): 0 -- *Dancing Lights, Daze, Detect Magic, Disrupt Undead, Flare, Mage Hand, Ray of Frost, Read Magic, Resistance*; 1st -- *Longstrider, Mage Armor, Magic Missile, Ray of Enfeeblement, True Strike*; 2nd -- *Blindness/Deafness, Glitterdust, Invisibility, See Invisibility, Web*; 3rd -- *Dispel*

*Magic, Lightning Bolt, Slow, Vampiric Touch*; 4th -- *Bestow Curse, Improved Invisibility, Solid Fog*; 5th -- *Cone of Cold, Feeblemind*.

Possessions: *Cloak of charisma +2, brooch of shielding*, assorted jewelry (6000 gp).

\* Included pre-cast *mage armor* spell.

#### **Encounter 8:**

**Strewth, Ettin, Bbn2/Ftr2/Rog5**; Large Giant; HD 5d6+10d8+2d10+2d12+76; hp 175; Init +6; Spd 50 ft; AC 21 (Flatfooted 19, Touch 11); Atk +24/+19/+14 melee (2d6+10, 19-20/×2, large *morningstar* +1) and +23/+18/+13 melee (1d8+10, 19-20/×4, large *heavy pick* +1); Face/Reach 10'/10'; SA: Sneak Attack (3d6); SQ: Darkvision 90', Evasion, Rage\*, Trapfinding; Uncanny Dodge; SV Fort +18, Ref +9, Will +6; AL NE; Str 28, Dex 14, Con 18, Int 8, Wis 10, Cha 8.

Skills & Feats: Intimidate +1, Listen +22, Search +2, Spot +14, Survival +4, Tumble +19. Alertness, Blind-Fight, Combat Reflexes, Improved Critical (Heavy Pick, Morningstar), Improved Initiative, Iron Will, Power Attack, Weapon Focus (morningstar).

Possessions: *Large morningstar +1*, large hide armor, *large heavy pick +1*, dead rat.

\* When raging, Strewth gains the following: Str +4 (and +2 to hit and damage), Con +4 (and +38 hp), and a +4 morale bonus to Will saving throws.

---

## Appendix Two: Cryllor

---

### Cryllor

*County of Cryllor, Pop. Gnomes 2,639; Halflings 1,668; Dwarves 5,221; Half-orcs 982; Humans 76,988*

**Background:** Cryllor is one of Keoland's wealthiest and most strategically powerful provinces. The county stretches along the banks of the Javan, in a fluvial valley cut by the river between the Good Hills and the Little Hills which border the lands of the Yeomanry League. The walled city of Cryllor (pop. 8,400), whose western district opens onto the banks of the Javan, is the fourth largest in the kingdom, after only Gradsul, Flen, and Niole Dra.

House Bazrial, the ruling House of Cryllor, is one of the ancient Suelese houses of nobility. Since the founding of Keoland some 900 years ago, Bazrial has always been one of the noble houses, although it is more prominent now than it was in many times passed. Bazrial has been the ruling house of this region for 500 years. However, the Manz family has not traditionally been the ruling family within the house. The house has undergone many internal struggles and changes, as one family or another came to the fore as a previous line died out. The Manz family only became the ruling family of House Bazrial 25 years ago, when the last of the Dreng family died and Ignas Manz, a powerful and wealthy mercenary captain who headed a cadet branch of the house, spread around enough money in the Council of Niole Dra to get his family recognized as the head of the house.

Recently, Count Ignas has suffered a very severe illness, confining him to bed and rendering him unable to attend to the business of the County. At 69, he is not old enough for dangerous diseases to be expected, but he is certainly less healthy than he used to be. The unusual ailment shows no signs of abating, and there are some who predict that he will never recover. A few weeks into his illness, his eldest child, Lora, sought and received a declaration from the Council of Niole Dra that she could act in his stead as Lady Regent until he either recovered or she inherited the formal title of Countess.

**Commerce:** The city and its wealthy Suel lord benefit strongly from the river traffic and trade that passes just outside his walls on the road connecting Niole Dra to Longspear. Additionally, riches are drawn from the lower Good Hills, most of which find their way to the markets of Cryllor.

**Politics:** The counties of Flen and Cryllor have been rivals for centuries, but while the rulership of Flen has been relatively stable over that time, the lordship of Cryllor has changed hands many times. Count Manz has long harbored the desire to annex the rich lands in the Little Hills, but has garnered no support to do so. He has made it clear that any alliance with Flen depends upon it. The western half of the province of Cryllor, referred to as the trans-Javan, extends from the western bank of the river to the foothills of the Jotens and the Little Hills. This land was recently acquired during the Greyhawk Wars, when forces of the count marched across the river, ostensibly to secure his lands from invasion from the Jotens. In so doing he has provoked the Yeomanry by mining the foothills of the Littles in abrogation of long-standing treaties. Many dwarves, gnomes and halflings suffer as second-class citizens. There are several reasons for this. First, many of those that sought refuge in Cryllor were demi-humans. The predominantly human populace does not distinguish between the natives and the refugees in the ghettos. Second, Cryllorans are particularly provincial in their views on magic. Possibly only the folk of Shelspring Barony enjoy a good witch-burning more. Many of the demi-humans are magical by nature and therefore not to be trusted. As a result of Crylloran mistreatment of their guildsmen, and their kinfolk in Cryllor and the Little Hills, the people of the Good Hills Union harbor great animosity toward Cryllor and its rulers.

### Notable People:

Ignas Manz, Count of Cryllor

Lora Manz, Lady Regent of Cryllor

Lady Delana, Secretary to the Lady Regent

Darvis Albrect, Special Functionary for the Secretary to the Lady Regent

Merla Hennig, Constable of Cryllor responsible for investigations



### **Gathering Information:**

Information is frequently traded in the Inns of Cryllor. Some prominent businesses appear below:

**The Unicorn's Crown.** Located in the Old City; a large wood and stone structure with a gold crown on a sign with a green background, The Unicorn's Crown is considered one of the best Inns of the city. A full menu of items from breakfast, lunch and dinner are available.

Proprietor: Vincent Ramblev.

Other notables: Terrel Gantle, bartender. An excellent source for information on the local nobility.

**The Falling Star.** Located in the Merchant's Quarter, the Falling Star is the largest Inn within the city. A sign with a gold star surrounded by 8 other smaller stars is displayed prominently in front of the mammoth wood building. This inn is reknowned for catering to adventurers and high end mercenaries.

Proprietor: Sir Amos Laishneigh.

Other notables: Lauren Laishneigh, Sir Amos' daughter. A valueable contact for adventurers and available mercenaries.

### **The Dead Dog Tavern**

Located in the Refugee Quarter, this sturdy wooden building is distinguished among the other ramshackle huts that surround it. A mostly intact sign of an inverted black dog gives little indication of the purpose of the dwelling.

Proprietor: Gerret, a man of questionable background with connections to professionals that do not hang a shingle outside their door.

Other notables: Meat, human bouncer. Rona Overhelm, waitress.

## Appendix Three: Copy Wight (New Monster)

---

### Copy Wight Apprentice

#### Small Outsider (Extraplanar)

**Hit Dice:** 2d8 (10 hp)

**Initiative:** +4

**Speed:** (20 ft. manifested or on home plane/30 ft. fly (perfect) incorporeal)

**Armor Class:** 16 (+4 Dex, +2 deflection), touch 16, flat-footed 12

**Attack:** +6 unarmed melee (1d2-2) or +6 touch (see SA below)

**Full Attack:** same as above

**Space/Reach:** 5 ft./5 ft.

**Special Attacks:** Spells, Touch of Idiocy/Touch of Enlightenment (3/day)

**Special Qualities:** Incorporeal, Copy Tome, Labyrinthine Confusion, Summon Tome

**Saves:** Fort +3, Ref +9, Will +5

**Abilities:** Str 6, Con 10, Dex 19, Int 16, Wis 14, Cha 14

**Skills:** +4, Craft (Bookbinder) +8, Decipher Script +12, Forgery +13, Hide +6, Listen +7, Move Silently +6, Search +8, and Spot +7.

**Feats:** Scribe scroll, Spell Focus: Enchantment, Weapon Finesse: Unarmed.

**Environment:** Libraries

**Organization:** Individual or Scriptorum (2-6)

**Challenge Rating:** 3

**Treasure:** Books

**Alignment:** Neutral

**Description:** Copy Wights are extraplanar spirits whose purpose in life is to preserve and protect knowledge. They are phantasmal creatures resembling adult humans, though small (3' tall) and thin with wispy white or light blue hair. They generally shrink from human contact, preferring the company of books and aspire to service in ever-greater storehouses of knowledge. Copy Wights may be summoned and bound into service by great wizards and bards who treasure their assistance in research.

**Combat:** Copy Wights are guardians of the libraries they inhabit. As such, they shun combat unless the library and its contents are threatened or creatures attempt to plunder the library's resources without permission. Weak combatants, they attempt to preserve the integrity of the library using subtlety. Once aware of intruders, they will create a zone of Labyrinthine Confusion, then attempt to disable opponents by silencing spellcasters and sleeping warriors, using incorporeality to the best of their ability. Their intent is to subdue their opponents until reinforcements arrive and minimize damage.

**Copy Tome (1/day):** Once per day, an apprentice may copy any non-magical document. The copy resembles the original and should be treated as a forged document made with a Forgery skill check of 20. Copy wights are not able to apply this ability to spell books, Boccob's Blessed Books and the like. Use of this ability requires 10 minutes after which the creature must rest for 1 hour.

**Labyrinthine Confusion (1/day):** In an area of up to 600 sq. ft., the Copy Wight may cast a zone of confusion. Where there are choices of direction, such as at corridor intersections or selecting the proper aisle in a library, a minor confusion-type effect functions, making it 50% probable that creatures other than the Copy Wight believe with conviction that they are going in the opposite direction than the one they actually chose. This is an enchantment, mind-affecting effect. Casting time: standard action. Duration: 3 hours or until discontinued by caster. Saving Throw: Will (DC 18). Spell Resistance: Yes.

**Summon Tome (3/day):** The Copy Wight may draw upon the resources of the library it inhabits. This ability functions like the Bardic Knowledge ability. Using a standard action, the creature may cause a book containing information relevant to a particular topic or question to appear in its hand. It may then make a Knowledge check

with a + 9 bonus and consult the Bardic Knowledge table (PHB p. 28) to determine the information gleaned. Actually consulting the summoned tome requires 1 minute.

**Touch of Idiocy/Touch of Enlightenment (3/day):** As a touch attack, a Copy Wight may use Touch of Idiocy as a standard action. Conversely, the spirit may aid another creature in its studies with a burst of enlightenment, granting a 1d6 bonus to the target's Int, Wis and Cha for a period of 30 minutes.

**Spells:** The following spells are usable 3 times/day as a 3<sup>rd</sup> level caster. Arcane Lock, Comprehend Languages, Dancing Lights, Light, Mending, Open/Close, Sleep, Silence, Unseen Servant.

**Skills:** A Copy Wight has a + 4 racial bonus to Decipher Script, Forgery, Listen, Search, and Spot.

### Copy Wight Scrivner

#### Small Outsider (Extraplanar)

**Hit Dice:** 6d8 (30 hp)

**Initiative:** +5

**Speed:** (20 ft. manifested or on home plane/30 ft. fly (perfect) incorporeal)

**Armor Class:** 17 (+5 Dex, +2 deflection), touch 17, flat-footed 12

**Attack:** +10 unarmed melee (1d2-2) or +10 touch (see SA below)

**Full Attack:** +10/+5 unarmed melee (1d2-2) or +10 touch (see SA below)

**Space/Reach:** 5 ft./5 ft.

**Special Attacks:** Spells, Touch of Idiocy/Touch of Enlightenment (6/day)

**Special Qualities:** Incorporeal, Copy Tome, Labyrinthine Confusion, Summon Tome

**Saves:** Fort + 6, Ref + 15, Will +11

**Abilities:** Str 6, Con 10, Dex 20, Int 16, Wis 14, Cha 14

**Skills:** Concentration +8, Craft (Bookbinder) +12, Decipher Script +14, Forgery +15, Hide +11, Knowledge (Literature) +7, Knowledge (History) +7, Knowledge (Planes) +7, Listen +9, Move Silently +11, Search +12, and Spot +9.

**Feats:** Scribe scroll, Spell Focus: Enchantment, Weapon Finesse: Unarmed +1 feat

**Environment:** Libraries

**Organization:** Individual or Scriptorum (2-6)

**Challenge Rating:** 6

**Treasure:** Books

**Alignment:** Neutral

**Description:** As above.

**Combat:** As above

**Copy Tome (2/day):** Once per day, an apprentice may copy any non-magical document. The copy resembles the original and should be treated as a forged document made with a Forgery skill check of 20. Copy wights are not able to apply this ability to spell books, Boccob's Blessed Books and the like. Use of this ability requires 10 minutes after which the creature must rest for 1 hour.

**Greater Unseen Servant (6/day):** As Unseen Servant, but capable of moving 40 lbs. Duration 1 hour/use.

**Labyrinthine Confusion (2/day):** In an area of up to 900 sq. ft., the Copy Wight may cast a zone of confusion. Where there are choices of direction, such as at corridor intersections or selecting the proper aisle in a library, a minor confusion-type effect functions, making it 50% probable that creatures other than the Copy Wight believe with conviction that they are going in the opposite direction than the one they actually chose. This is an enchantment, mind-affecting effect. Casting time: standard action. Duration: 3 hours or until discontinued by caster. Saving Throw: Will (DC 19). Spell Resistance: Yes.

**Summon Tome (6/day):** The Copy Wight may draw upon the resources of the library it inhabits. This ability functions like the Bardic Knowledge ability. Using a standard action, the creature may cause a book containing information relevant to a particular topic or question to appear in its hand. It may then make a Knowledge check with a + 9 bonus and consult the Bardic Knowledge table (PHB p. 28) to determine the information gleaned. Actually consulting the summoned tome requires 1 minute.

**Touch of Idiocy/Touch of Enlightenment (6/day):** As a touch attack, a Copy Wight may use Touch of Idiocy as a standard action. Conversely, the spirit may aid another creature in its studies with a burst of enlightenment, granting a 1d6 bonus to the target's Int, Wis and Cha for a period of 60 minutes. This ability may be used once per round.

**Spells:** At will as a 7<sup>th</sup> level caster: Dancing Lights, Light, Mending, Open/Close. 6 times/day as a 7<sup>th</sup> level caster: Comprehend Languages, Mage Armor, Silence. 3 times/day as a 7<sup>th</sup> level caster: Arcane Lock, Deeper Slumber, Sleep, Tongues.

**Skills:** A Copy Wight has a + 4 racial bonus to Decipher Script, Forgery, Listen, Search, and Spot.

### Copy Wight Master

#### Small Outsider (Extraplanar)

**Hit Dice:** 10d8 (50 hp)

**Initiative:** +5

**Speed:** (20 ft. manifested or on home plane/30 ft. fly (perfect) incorporeal)

**Armor Class:** 18 (+5 Dex, +3 deflection), touch 18, flat-footed 13

**Attack:** +14 unarmed melee (1d2-2) or +14 touch (see SA below)

**Full Attack:** +14/+9 unarmed melee (1d2-2) or +14 touch (see SA below)

**Space/Reach:** 5 ft./5 ft.

**Special Attacks:** Spells, Touch of Idiocy/Touch of Enlightenment (9/day)

**Special Qualities:** Incorporeal, Copy Tome, Labyrinthine Confusion, Summon Tome

**Saves:** Fort + 9, Ref +20, Will +16

**Abilities:** Str 6, Con 10, Dex 20, Int 16, Wis 14, Cha 16

**Skills:** Concentration +12, Craft (Bookbinder) +14, Decipher Script +16, Forgery +17, Hide +15, Knowledge (Literature) +7, Knowledge (History) +7, Knowledge (Planes) +7, Knowledge (Politics) +7, Knowledge (Nobility) +7, Knowledge (Arcana) +7, Listen +12, Move Silently +15, Search +15, and Spot +12.

**Feats:** Scribe scroll, Spell Focus: Enchantment, Weapon Finesse: Unarmed. +2 feats

**Environment:** Libraries

**Organization:** Individual

**Challenge Rating:** 10

**Treasure:** Books

**Alignment:** Neutral

**Description:** As above

**Combat:** As above.

**Copy Tome (3/day):** Once per day, an apprentice may copy any non-magical document. The copy resembles the original and should be treated as a forged document made with a Forgery skill check of 20. Copy wights are not able to apply this ability to spell books, Boccob's Blessed Books and the like. Use of this ability requires 10 minutes after which the creature must rest for 1 hour.

**Greater Unseen Servant (6/day):** As Unseen Servant, but capable of moving 60 lbs. Duration 1.5 hour/use.

**Labyrinthine Confusion (3/day):** In an area of up to 1350 sq. ft., the Copy Wight may cast a zone of confusion. Where there are choices of direction, such as at corridor intersections or selecting the proper aisle in a library, a minor confusion-type effect functions, making it 50% probable that creatures other than the Copy Wight believe

with conviction that they are going in the opposite direction than the one they actually chose. This is an enchantment, mind-affecting effect. Casting time: standard action. Duration: 9 hours or until discontinued by caster. Saving Throw: Will (DC 21). Spell Resistance: Yes.

**Summon Tome (9/day):** The Copy Wight may draw upon the resources of the library it inhabits. This ability functions like the Bardic Knowledge ability. Using a standard action, the creature may cause a book containing information relevant to a particular topic or question to appear in its hand. It may then make a Knowledge check with a + 9 bonus and consult the Bardic Knowledge table (PHB p. 28) to determine the information gleaned. Actually consulting the summoned tome requires 1 minute.

**Touch of Idiocy/Touch of Enlightenment (9/day):** As a touch attack, a Copy Wight may use Touch of Idiocy as a standard action. Conversely, the spirit may aid another creature in its studies with a burst of enlightenment, granting a 1d6 bonus to the target's Int, Wis and Cha for a period of 30 minutes.

**Spells:** At will as an 11<sup>th</sup> level caster: Dancing Lights, Light, Mending, Open/Close. 9 times/day as an 11<sup>th</sup> level caster: Comprehend Languages, Mage Armor, Silence. 6 times/day as an 11<sup>th</sup> level caster: Arcane Lock, Deeper Slumber, Sleep, Tongues. Once/day as an 11<sup>th</sup> level caster: Symbol of Sleep, Mass Suggestion, Symbol of Stunning.

**Skills:** A Copy Wight has a + 4 racial bonus to Decipher Script, Forgery, Listen, Search, and Spot.



Notice to Shareholders in  
A PENCHANT FOR DRINK

A meeting will be held on Moonday, 17th Ready'reat at the Roc's Feather in Buckshold to conclude business of the past year and prospects for the year to come. Food and drink will be provided exclusively to Shareholders. Financial advisors M. Trimble and J. Gimble of Pindangoogly Investments have informed the proprietors of Penchant Co. that free Lambic will seriously impact the brewery's profits. This letter entitles the bearer to one tankard full of Lambic on the 17<sup>th</sup>.

P. Penchant

## Player Handout #2: Wanted Posters

---

<p><b>Wanted:</b> <b>The Low Road Bandit</b></p>  <p>Elf-blooded ruffian leads notorious gang of thieves wanted by the Good Hills Militia. Reward posted by Artin Billows, Buckshold</p>	<p><b>Wanted:</b> <b>The Green Warlock</b></p>  <p>Pale, blonde-haired man of average height wanted dead or alive. Last seen in the western Good Hills. Known practitioner of forbidden magics. Extremely dangerous. Contact Meria Hennig, Constable, Cryllor. 1000 lion reward posted for information leading to his capture.</p>
---	--

*Drink Pemlo's Lambic  
the draught of Kings*

Player Handout #3: A Tattered Page

---

Your line must be so

When the last son falls, so falls the crown.  
Shield of the West, You must remain."

But they have all been taken from me. My beloved Gwaeddan.  
My poor brave boy. All of my hopes rested with him.  
They will be coming for me soon. I will be next and the  
Dreng name with me. Fools and cowards.

CR VOL. 123



**THE RIDDLE OF THE PORTAL:**

**YOU CAN FIND US IN DARKNESS BUT NEVER IN LIGHT.**

**WE ARE THERE IN DAYTIME BUT ABSENT IN NIGHT.**

**IN THE DEEPEST OF SHADOWS, WE HIDE IN PLAIN SIGHT.**

**WHAT AM I?**

## Player Handout #5: The Chronicle of Cryllor

---

Excerpts appear below:

### **541CY**

Ah, I remember when I first saw her on that hunting trip near Baelefract. She was young and beautiful and I was old and fallen ill with fever after 3 days in the damp highlands. I do not what Gwaeddan saw in me, but I am thankful it was not the infirm old man I appeared. That woman has changed my wife, Kelannen willing, will give me a worthy heir. Gillick still thinks me a doddering fool for trusting her...

---

What a glorious day! Only a handful of the lords were in attendance. Manz, Wilfrick, Thale, the King's man. Many in the Council still question my sanity publicly when the matter is really purity of blood. Purity! It will tear us apart. They could not be allowed to spoil Gwaeddan's wedding day.

---

Perhaps a holiday is what we need. Gwaeddan is growing large with child. In her delicate condition she does not need to hear the catcalls from the rabble or the invective at court. In more settled times I would have Kelson quartered for his comments about "the maid" ruling the court. Baelefract is beautiful this time of year and we have not been there since Gwaeddan first caught my eye. It will calm my nerves.

---

Trusted Manz visited today. I am glad to have him attending court on my behalf. He is so unlike the prancing slanderers that pass for lords or Cryllor. He brought news of a loss to the Crylloran Court. Lord Kelson suffered a tragic accident while riding. Send lilies.

---

Since taking my father's seat, the Dreng prophesy has haunted me. Today a shadow has been lifted from my mind. Gwier is born. A beautiful boy of clear eye and powerful lung. How he raged! Never content out of his mother's arms.

---

My heart is light. The Dreng name, the County and the Empire have a bright future.

A quick scan of this heavy volume reveals it to be a formal record of state. Deeper in the tome, you find marginalia with greater and greater frequency: mad scribbles of Count Dreng, last ruler in his line, as he sank deeper into the embrace of paranoia. Over a span of sixteen years, many tragedies befell the Count, starting with the death of the Countess, his wife of many years. There are moments of hope and happiness documented too: finding love late in life in Gwaeddan, a Flan country girl; and the birth of his first son, Gwier. These moments are lost in a flood of misfortune: the deaths of his daughter; political unrest in Cryllor; the death of his wife, and finally the death of his son, Gwier, in the Jotens. The news of his death apparently broke the Count's sanity once and for all. His entries end with the torn page whose match you hold. The rest of the volume is filled with paranoid ravings. The Volume is closed with the twin seals of Valdin Thule, Special Consul to the King and Ignaz Manz, Count-elect of Cryllor.

Nothing more can be gleaned without a great deal of scrutiny.

## Player Handout #6: Missives from the Emissary

---

Sealed messages from the saddlebag of the Emissary:

Three are represented below. There are a dozen in total.

**1. Sealed scroll with a green “G” seal. Text below is translated from orcish pictograms.**

Querm,

Prove you strength and ferocity to me. There is a bridge across the Javan a half-day run north of the town of Kilm, proud battlefield of your tribe. Seize it and hold it one moon hence. The many tribes will use this bridge to take food from the Lion.

The One Eye will smile. The bladders of his enemies will empty in fear.

Brother in Blood,

G

**2. Fine quality envelope sealed with a green “G.” Text below is translated from Ancient Sueloise.**

My good friend Golfin,

The Filbolg clan of the Black Cedar Pass have been uncooperative. They threaten the flank of our forces. As none of the lesser giants were members of the debate team back at the Academy, I have need of your skills. Use diplomacy to smooth things over with Chief Brodabinang and promise what you must, but gain free passage for our forces. Once Buckshold is secured we can resolve matters with the Filbolgs once and for all. If you require bodyguards, retain them at the “guardpost.”

G

**3. This message is sealed with plain black wax in a non-descript envelope titled “Wild Hare.” The characters are Common.**

fimrgvssolsppsasrxlviiviehcviexqiixfvsvxivlsshekirxxshmwgywwjexisjipkevrmam  
ppwirhwtigmjmgwqerdamppepperhqcjexlivviwxexpewxmrlmwkvezi