

KEO1-06

EVIL IN THE WOODS

A One-Round D&D LIVING GREYHAWK[®]

Keoland Regional Adventure

Version 1

ROUND 1

by Jeffrey Cuttler

The Dreadwood Forest has never been a more dangerous place to be. Horrible monsters are ransacking caravans, villages are being raided and people are disappearing. Is it business as usual near the Dreadwood Forest or is there something else, some other evil in the woods? An adventure for characters level 1-6.

DUNGEONS & DRAGONS, D&D, GREYHAWK and RPGA are registered trademarks of Wizards of the Coast, Inc. LIVING GREYHAWK is a trademark of Wizards of the Coast, Inc. Scenario detail copyright 2001 by Wizards of the Coast, Inc. ALL RIGHTS RESERVED. This scenario is intended for tournament use only and may not be reproduced without approval of the RPGA Network.

This is an RPGA® Network scenario for the Dungeons & Dragons® game. A four-hour time block has been allocated for each round of this scenario, but the actual playing time will be closer to three hours. The rest of the time is spent in preparation before game play, and scoring after the game. The following guidelines are here to help you with both the preparation and voting segment of the game. Read this page carefully so that you know and can communicate to your players the special aspects of playing an RPGA scenario.

PREPARATION

First you should print this scenario. This scenario was created to support double-sided printing, but printing it single sided will work as well. There is enough room along the inside margin to bind the adventure, if you desire.

Read this entire adventure at least once before you run your game. Be sure to familiarize yourself with any special rules, spells, or equipment presented in the adventure. It may help to highlight particularly important passages.

When you run an RPGA D&D adventure we assume that you have access to the following books: the *Player's Handbook*, the *Dungeon Master's Guide*, and the *Monster Manual*. We also assume that you have a set of dice (at least one d4, d6, d8, d10, d12, and d20), some scrap paper, a pencil, an RPGA scoring packet, and your sense of fun. It is also a good idea to have a way to track movement during combat. This can be as simple as a pad of graph paper and a pencil, as handy as a vinyl grid map and chits, or as elaborate as resin dungeon walls and miniatures.

Instruct the players either to prepare their characters now, or wait until you read the introduction, depending on the requirements of the scenario as described in the introduction.

Keep in mind that you must have at least four players (not counting the DM), for the game session to be a sanctioned RPGA event. As well, you cannot have more than seven players participating in the game.

Once you are ready to play, it is handy to instruct each player to place a nametag in front of him or her. The tag should have the player's name at the bottom, and the character's name, race, and gender at the top. This makes it easier for the players (and the DM) to keep track of who is playing which character.

The players are free to use the game rules to learn about equipment and weapons their characters are carrying. That said, you as the DM can bar the use of even core rule books during certain times of play. For example, the players are not free to consult the *Dungeon Master's Guide* when confronted with a trap or hazard, or the *Monster Manual* when confronted with a monster.

Some of the text in this scenario is written so that you may present it as written to the players, while other text is for your eyes only. Text for the players will be in gray boxes. It's strongly recommended that you paraphrase the player text instead of reading it aloud. Some of this text is general and must be adapted to the specific situation or to actions of the player characters.

SCORING

After the players have completed the scenario or the time allotted to run the scenario has run out, the players and DM score the game. The RPGA has three ways to score its games. Consult your convention coordinator to determine which method to use for this scenario:

1. No-vote scoring: The players write their names and RPGA numbers on the scoring packet grid. You fill in the top of the grid. That is all. No one is rated. This method is used for people who are just playing for fun.
2. Partial scoring: The players rate the game master and the scenario on their player voting sheet, and provide personal information, but don't vote for other players. The game master rates the scenario and completes personal and event information, but does not rate the players as a team or vote for players. This method is used when there is no competition, but the event coordinator wants information on how the game masters are performing, or the game master wants feedback on his or her own performance.
3. Voting: Players and game masters complete the entire packet, including voting for best player. If this method is used, be sure to allow about 15-20 minutes for the players to briefly describe their characters to the other players, and about 5-10 minutes for voting. This method is used when the players want to know who played the "best" among the group, or when the adventure is run in tournament format with winners and prizes.

When using voting, rank the players in order of your voting choice while they are completing their forms, so that you are not influenced by their comments on your abilities. It's a good idea to have the players vote while you determine treasure and experience awards for the scenario.

After voting, give the Scoring Packet to your event coordinator.

This is a LIVING GREYHAWK Adventure. As a Living™ adventure, it is expected that players will bring their own characters with them. If players do not have a LIVING GREYHAWK character generated, get a copy of the current LIVING GREYHAWK character generation guidelines, a character sheet, and a LIVING GREYHAWK log sheet from your convention coordinator or the RPGA Web site, and then have any players without a character create one. Once all players have a LIVING GREYHAWK character, play can begin.

Along with the other materials that you are assumed to have in order to run a D&D game, it is also recommended that you have a copy of the LIVING GREYHAWK Gazetteer.

DETERMINING AVERAGE PARTY LEVEL (APL)

Because players bring their own characters to LIVING GREYHAWK games, this adventure's challenges are proportioned to the average character level of the PCs participating in the adventure. To determine the Average Party Level (APL):

- 1) Determine the character level for each PC participating in the adventure.
 - 2) If PCs bring animals that have been trained for combat (most likely war horses, dogs trained for war), other than those brought by virtue of a class ability (i.e., animal companions, familiars, paladin's mounts, etc.) use the following chart to determine the number of levels you add to the sum above. Add each character's animals separately. A single PC may only bring four or fewer animals of this type, and animals with different CRs are added separately.
- | CR | 1 | 2 | 3 | 4 |
|-------------|---|---|---|---|
| 1/4 and 1/6 | 0 | 0 | 0 | 1 |
| 1/3 and 1/2 | 0 | 0 | 1 | 1 |
| 1 | 1 | 1 | 2 | 3 |
| 2 | 2 | 3 | 4 | 5 |
| 3 | 3 | 4 | 5 | 6 |
| 4 | 4 | 5 | 6 | 7 |
- 3) Sum the results of 1 and 2, and divide by the number of characters playing in the adventure—round up.
 - 4) If you are running a table of six PCs, add one to that average.

By following these four steps, you will have determined the APL. Throughout this adventure, APLs categorize the level of challenge the PCs will face. APLs are given in even-numbered increments. If the APL of your group falls on an odd number, ask them before the adventure begins whether they would like to play a harder or easier adventure. Based on their choice, use either the higher or the lower adjacent APL.

APL also affects the amount of experience you may gain at the end of an adventure. If your character is three character levels or more either higher or lower than the

APL that this adventure is played at, that character will receive only half of the experience points awarded for the adventure. This simulates the fact that either your character was not as challenged as normal, or relied on help by higher-level characters to reach the objectives.

Note: LIVING GREYHAWK adventures are designed for APL 2 and higher. Three or four, or sometimes even five 1st-level characters may find difficulty with the challenges in a LIVING GREYHAWK adventure. If your group is APL 1 there are three things that you can do to help even the score.

- 1) Attempt to create a table of six 1st-level characters, or try to enlist higher-level characters to play at that table.
- 2) Advise characters to buy riding dogs to help protect them, and fight for them. All riding dogs are considered trained to attack. PCs who want their dog to attack they must succeed at a Handle Animal or Charisma check (DC 10). Failure indicates that the animal will not attack that round. This is a free action (spoken command) that may be attempted each round. If an animal loses half or more hp in a single round it flees, unless another check is successful.
- 3) A group of APL 1 adventurers who desire an extra hand can "enlist an iconic." The stats for the 1st-level versions of Tordek, Mialee, Lidda and Jozan are given at the end of each adventure. The group may pick one of these characters to joint them on this adventure. The DM controls that NPC.

If you are using a 591 CY adventure (campaign year 1) that uses the old APLs, assume that the APL multiplied by 2 is the APL suitable for that encounter.

IS IT A FULL MOON?

Since the hazards of lycanthropy are a current part of the LIVING GREYHAWK campaign, it may be necessary to determine if this adventure takes place during a full moon. For game purposes, the full moon lasts three days of each month. For a given scenario that does not state the phase of the moon, roll 1d10 before play begins. On a result of 1, the first day of the scenario is a night of the full moon (roll 1d3 to determine where in the sequence of three nights it falls).

LIFESTYLE

At the beginning of every scenario, each PC is required to pay upkeep costs matching the level of lifestyle they wish to maintain. The lifestyles, and the effects that each has on play, are:

Destitute: You have no living space, and must carry all your gear everywhere. You eat poor quality food. You wear a peasant outfit, your only change of clothes.

Poor: You sleep in poor accommodations, and eat poor quality food. You wear a peasant outfit, and have two sets of clothing.

Common: You have common lodgings, and eat common quality food. You have normal clothing for your profession (adventuring); nothing fancy. You probably have two or three sets of clothing.

High: You stay in good quality lodgings, and eat good quality food. You wear anything in value up to 100 gp outfits, and generally buy a new set of clothing every two weeks.

Luxury: You have luxurious accommodations (twice the cost of good accommodations), and you eat excellent foods. You can throw a banquet for your friends every day, and frequently do. You wear clothing up to the value of noble's outfit, and buy a new set of clothes every week.

Lifestyles come with bonuses or penalties to Diplomacy, Intimidate, Disguise, and Bluff skill checks. These penalties, shown below, should be applied at the DM's discretion, and can sometimes backfire—for example, a PC with a poor lifestyle would not have a penalty when talking to a beggar, but would when talking to a city official. A PC with a high lifestyle should have a penalty when dealing with a group of street thugs, where a PC with a destitute lifestyle might not.

DMs are encouraged to role-play these reactions whenever possible.

Lifestyle Cost	Skill Modifier	
Destitute	14 sp	-2
Poor	43 sp	-1
Common	12 gp	0
High	250 gp	+1
Luxury	500 gp	+2

ADVENTURE SUMMARY AND BACKGROUND

STORY – ANCIENT HISTORY

When the Gods were young, and still unsure of their power, a cleric of an ancient evil rose to prominence. This cleric, Thestos, enslaved man and humanoid alike and forced their fealty to the evil power that he served. This nameless, dark power fueled his loyal cleric's abilities and together they began to cut a swath of terror and carnage across the areas now called Geoff, Sterich and Keoland. Their reign of terror was short lived. As they began to destroy the Dreadwood Forest an ancient guardian began to stir. Native people and creatures of the Dreadwood were inspired to fight back. Protectors of the Forest began to hunt Thestos and his forces, following their trail of death and destruction. Although Thestos had dark divine power coursing through his body, he was out of his

element among the natural, and unnatural, defenders of the Dreadwood. The battle was fierce and bloody, the ancient evil did not let his vassal go easily, but in the end Thestos was brought low. Try as they might, the Protectors of the Forest were unable to destroy the body of the evil cleric. They used fire, cold and acid all to no avail. Faced with this dilemma, the Protectors of the Forest decided to deeply bury the body within the Dreadwood where they could watch it and prevent any evil that it could cause. Thestos lay dormant for a millennium, waiting for the right time to surface and once again ravage the realm of man . . .

STORY – RECENT HISTORY

The Free City of Greyhawk is a spectacular, dizzying city of delights where a body might find all that it craves and desires. Such is the case with Naxalon Fenn, a cleric in the service of the death-god Nerull. While studying ancient texts within the great libraries of Greyhawk, a page of ancient text dislodged itself from the binding. Naxalon quickly picked up the piece and tucked it inside his robe for fear that he would be punished and banned from the library. Naxalon quickly made his way back to his lodging fearing that he might be stopped at anytime. Safely tucked away in his room, Naxalon looked at the piece of text that had caused him so much grief. As he inspected the page, he noticed that it seemed to be two pieces craftily bound together. Much to his surprise and delight, the secret page revealed a map showing a portion of what seemed to be the Dreadwood forest in Keoland. The markings on this map seemed to Naxalon to indicate that a great relic of Nerull's power lay beneath the Dreadwood forest.

Eager to please his god, and increase his own power, Naxalon gathered together a band of adventurers to investigate, as he described it, the "treasure" map. This group included a half-orc Barbarian, human fighter, human mage and a half-elven rogue. Together they made their way from the Free City of Greyhawk down the coast of the Woolly Bay slipping between the Suss Forest and the Drachensgrab Hills until they could reach the Jewel River. From there they journeyed down the river to where it meets the Azure Sea and followed the coastline, passing Gryrax, until they reached Gradsul. Gathering supplies and information, the group made their way to the Dreadwood in search of the "treasure".

The Dreadwood was not hospitable to these adventurers but eventually they made their way to the burial marker shown on their map. After deciphering the riddle, the marker opened up revealing a rough tunnel that led deep into the bowels of the earth. Following the tunnel, the cleric of Nerull and his band of adventurers discovered a crypt covered with strange, ancient markings of power. Upon opening the crypt, the group looked upon the body of Thestos, a body that seemed untouched by the ravages of time. It was the last sight they would ever see. A sudden, powerful necromantic force erupted from Thestos, ripping through the underground chambers and spilling upwards into the forest area surrounding the burial marker. This area

became even more dark, twisted and evil than it had been before. Trees and plants became sickened, poisoned and thorny. Distorted animals stalked with aggressive natures. While below in the crypt chambers one person was still standing, Naxalon Fenn- Cleric of Nerull. It seems that Thestos had plans for the cleric. Thestos was to use Naxalon Fenn the way he had been used by his dark and unholy deity. Naxalon was to help unleash an army of undead to ravage the Dreadwood and beyond. The band of adventurers that accompanied Naxalon began to rise as zombies and started to roam the countryside. These zombies kidnapped hapless villagers, sometimes children and brought them back to Thestos to be turned into zombies or skeletons. Naxalon Fenn was being fed a portion of Thestos's dark power and was beginning to crave it more and more. His spells were more powerful, he felt stronger and this dark power seemed to form a "protective" cocoon around him. "This is a treasure indeed!" Naxalon thought to himself. How wrong he is!

ADVENTURE SYNOPSIS

A necromancer finds a treasure map that leads him to the dead body of a powerful evil cleric buried in the Dreadwood. The necromancer finds the body and (accidentally) unleashes some of its power. Animals and plants become distorted, sick and evil in the area. Animals become mutated and aggressive. The band of adventurers who helped find the body are turned into zombies and ghouls by the Evil Cleric's body. These ghouls and zombies venture forth in the night and have been stealing people from the villages for the necromancer's experiments and to be added to the undead force.

Encounters

- Characters meet in Gradsul and hear rumors.
- PCs are paid by the Caravan and guard it across the Dreadwood OR PCs go ahead, on their own, to investigate the rumors from Encounter 1.
- Meet the Rhennee and the Old Woman who tells fortunes. (Dependent on choice from Encounter 2)
- Stay over at the small town of Oakroot. (with or without Caravan)
- Rescue girl from zombies and ghouls in well. Find treasure.
- Townspeople tell PCs that a group of adventurers traveled through recently. They talked about going into the Dreadwood to find treasure. One of the local scouts can guide them.
- PCs investigate the Dreadwood. Attacked by Owlbear(s) as they near the Crypt.
- Find Crypt of the Evil Cleric. Solve puzzle/riddle or find some other way into Crypt.
- Enter Crypt and battle zombies, ghouls and Necromancer fueled by the power of the Evil Cleric. Find Treasure.
- Interact with Dreadwalkers after the battle.

INTRODUCTION

Players are drawn to the port city of Gradsul for various reasons. It could be the end point of an adventure for some, seeing off a church dignitary or friend on a safe sea voyage. PCs are possibly coming in from a sea voyage themselves. Whatever the reason, they are in Gradsul at the same time and at the same tavern during a local holiday dedicated to Procan. The holiday asks Procan for prosperous fishing during the upcoming season. Find out if the players are coming together or in separate groups. Find out whom the groups will consist of.

ENCOUNTER 1: THE BAR

You find yourself in Gradsul, a bustling port city of tremendous proportions located on the western shores of the Azure Sea. The city streets are alive and filled with energy because the Fishing Festival of Procan is in full swing. The streets are filled with people drinking, dancing and generally enjoying the festival and the good tidings that it brings. You find yourself jostled by many people in the crowded streets as you try to find a meal and a room. Street vendors entice you with their wares but suddenly you see a tavern that looks inviting. A large crowd of people has just left the tavern. Surely there is room enough for you to find a meal, a drink or even lodging. Dodging in and out through the crowd, you head toward the Red Belly Inn.

The PCs find themselves at the Red Belly Tavern in the port city of Gradsul. A local holiday called the Fishing Festival of Procan is being observed and the local watering holes are filled to bursting. If "forced" to meet each other, make PC introductions by seating them at the same table. When the PCs order, have the waitress mess up the order and only bring enough for one or two of the players or bring out the wrong order as a role-playing hook. Have the waitress never hear their calls for service or simply say "I'll be right there!" and never show up.

Development: During their time in the tavern the players hear of three adventure hooks:

- Caravans are being raided by monsters on the road from Gradsul past the Dreadwood Forest. (true)
- Adults and children have been disappearing from nearby villages over the past month. (true)
- Strange wanderers are in the far south and west areas outside the city and are stealing children to train and use them as thieves. (false).
- A huge Green Dragon lives in the Dreadwood Forest. (false . . . I think)

At this point the PCs should take the "bait" for one, or more, of these hooks. If they don't take any of the hooks, send them back to the farm to milk the cows! They are not cut out to be heroes.

If the PCs choose to Gather Information (DC 15), or slip a 10gp bribe to Bovo the Bartender, they find out the following:

- There is a Caravan heading out on the western road tomorrow. Grifo is the man in charge of the Caravan and he is looking for some bodyguards. Go to Encounter 2.
- The missing people came from villages to the west of the city. Go to Encounter 3.
- Strange people in wagons have been sighted on the roads outside the city. There is an old woman among them that can see the future. Go to Encounter 3.

ENCOUNTER 2: THE CARAVAN

The caravan is being formed near the western gates. A feeling of activity and excitement shows in everything you see. Horses and wagons are being tethered together while other people are loading up wagons. There are two groups of people at the head of the caravan. They seem to be in a heated discussion.

The people at the front are Grifo the caravan leader and a band of adventurers. Grifo is crafty and greedy. He is not evil or completely dishonest but he will look for every advantage at every opportunity. Grifo is in negotiations with the adventurers for caravan duty. Grifo's other caravan was raided along the Dreadwood and he lost most of his cargo. This caravan must go through or he will be in debt to some very nasty people. One of the adventurers (Tanca) survived the caravan raid. Tanca was the only one from his former adventuring comrades to live. He is now arguing for more money for his current group of adventurers. Tanca is angry with Grifo because he believes that Grifo knew about the dangers and did not warn them. Tanca now wants revenge for the death of his friends from the beasts that killed them and also from Grifo for lack of disclosure. The group he is with now are not his friends, just some brutish thugs he gathered together so that he could exact revenge. An Owlbear attacked Tanca's group as they passed by the Dreadwood on caravan duty.

Grifo will try to hire the PCs to guard the caravan for the same amount of money (30 gold per person) he is offering to Tanca's group. If pressed (Intimidation, Charm or whatever), Grifo will offer the PCs the amount Tanca was asking for (50 gold per person). He does this to snub his nose at Tanca because he was unable to guard the first caravan. Tanca will hate the PCs and will seem threatening. Tanca will make some vague reference to the "Boogey Beast" (Owlbear). He will back down from a fight immediately. **DO NOT ALLOW THIS TO ESCALATE INTO A FIGHT!!!**

The cargo is salted fish, clothing and silks. The caravan is heading to the town of Quadpoint.

Go to Encounter 4.

☛ **Grifo:** Male human Exp3.

ENCOUNTER 3: THE STRANGERS

Riding to the South will not produce any type of encounter. Riding to the West will. PCs can ride along the road and should be encouraged to do so as it will be much quicker than walking. Horses can be purchased as in the Players Handbook. A few days of riding pass without any incidents of note until night time of the 7th day. After the evening meal, two wagons begin to head toward the PCs direction.

The people in the wagon are the land wandering Rhennee commonly called Attloi by their fellows. Rhennee are exceptionally rare in Keoland and those few are found only up north in the Duchy of Dorlin. This group has wandered south for their own cryptic reasons, though fate has conspired to have them cross the path of the players.

As the evening begins to fade into night, the distant sounds of horses can be heard.

Appropriate checks can be made to discover information .

The first wagon has two drivers with loaded crossbows. Inside there are four other olive-skinned males in colorful garb with short swords.

The second wagon also has two drivers with loaded crossbows. Inside there is one man w/short sword, one young woman, one old woman and five young children.

Two brightly colored wagons, each drawn by two horses, clang and clatter their way toward your camp. Olive skinned men drive the wagons and look to have crossbows at their side. They stop their wagons 100 feet before your camp. One of the drivers dismounts and begins to walk toward your camp.

The men in the wagons are opposed to this meeting but the matriarch of the clan, the "Old Woman", was insistent. The Old Woman feels the sense of destiny that surrounds the PCs and the evil that they will confront. She wants this "evil in the woods" to be vanquished and that is the only reason why she is willing to help the PCs with a fortune telling.

"I am Stilgo, leader of these men behind me. You have been "invited" to join us for the evening." He pauses, "The Old Woman wants to see you. All of you . . ."

Before any of you can form the questions racing through your mind, Stilgo turns and begins to walk back to the Wagons and pauses, he calls out "I wouldn't want to be the one who keeps her waiting" and he continues to make his way back to the wagons.

The PCs that go to the wagons will see several men sitting to one side of the fire speaking among themselves. They do not appear to be overly friendly. Closer to the fire

there is a young woman, Lana, and several children tending to the evening meal. Some of the children are playing. The young woman is trying to watch both the evening meal and the children.

Just outside of the firelight sits a shadowy figure who motions the PCs to come closer.

“I am Tula, the one called the Old Woman. I have the gift of the ‘Sight’. I see many things, things others cannot. I see your group has a role in the web of destiny. Tell me what has transpired thus far.”

Allow PC explanations and questions for a short time.

The Old Woman is proud and will not brook disrespect about her people or her powers. She will cast the “Curse of the Old-Woman” on PCs that ridicule anyone from the clan and/or insinuate anything about child stealing. (False Rumor from Encounter One)

The Old Woman lurches up from her seated position and speaks in a strange, low voice “Step forth, one by one into my wagon. I will use my gift to aid each one of you.” With that she moves toward one of the wagons.

She will be offended by those that do not accept her offer of a fortune telling. If the people who refuse her offer do not do so in a most “diplomatic” way, they will receive the “Curse of the Old-Woman”. Those that have their fortune told will receive the “Boon of the Old-Woman”.

They will also receive one of the following fortunes:

1. “fur and feather” guards the resting place of evil.
2. Ancient evil rests below the ground. Careful, or you may serve it willingly.
3. Evil offers the avenue for it’s own defeat.
4. Beyond the Veil is the true evil.
5. Forest protectors hold many secrets.
6. The Blessed Blade of an Evil Man will free the forest.

After the fortune telling, the Old Woman is too tired to speak. She falls into a magical sleep. If asked, Lana will tell the PCs that the Old Woman will sleep for the next ten-day after using her “Gift”.

The men will not engage in conversation nor do they have any information.

Go To Encounter 4

☞ **The Old Woman, Tula:** Female human Sor5/Vetha2.

☞ **Lana:** Female human Sor3.

☞ **Stilgo:** Male human Ftr4.

☞ **Rhennee Men (7):** Male human War1.

☞ **Rhennee Children (5):** Male and female humans Com1.

ENCOUNTER 4: OAKROOT

The days pass by uneventfully.

Ahead you see a small village.

The Village of Oakroot is on the outskirts of the Dreadwood. It is at the point where the Road and Dreadwood are nearest each other. There are approximately 200 people in Oakroot. There is a Center Square with a pavilion. There are some basic shops here as well as the Sapling Inn.

Note: If the PCs went to Encounter 3, mention that the Caravan from Gradsul is in Oakroot to refresh supplies.

A few hours after dinner the frantic cry of a woman can be heard.

“They have stolen my baby!!! Somebody help me!!!”

Outside a woman, Syl, is sobbing. She will tell the PCs that smelly, moldy men just took her daughter and climbed down a well on the east side of the village. She chased after them but couldn’t catch them. They weren’t at the bottom of the well when she got there They had disappeared.

If the players decide to help the woman, go to Encounter 5.

If the players refuse to help the woman, go to Encounter 7.

ENCOUNTER 5: THE WELL

The Well is easy enough to find with Syl leading the way. The well is about 50 feet deep. It is a simple stone well with a bucket and pulley.

A – The top of the well is unremarkable at first glance. There appears to be no where anyone could have gone once they climbed into the well. However, a careful search will reveal a switch just below the top of the well.

☛ **Secret Door:** Search (DC22).

The switch makes a platform slide out a few feet down from the lip of the well and a secret passage is revealed. The steps lead down 100 feet and levels out into a 10-foot wide corridor leading East.

The corridor leads East to B and branches off South to a corridor that leads to C.

B – The door to this room is unlocked.

Opening the door, you see a 20-foot by 30-foot room with a door in the south corner of the east wall. The room is bare, with no furnishings.

A number of humanoids are standing around in the room. At first you wonder if they are simply unaware of your

presence, but they suddenly turn as one and lurch toward you. As they do, a stench of death rolls off of them making your stomachs turn.

There is a secret door in the south wall that leads to D.

🔍 **Secret Door:** Search (DC22).

Creatures: A number of Zombies mill about the room.

APL 2 (EL 3)

👉 **Zombies** (4): hp 16 each; see *Monster Manual* page 191.

APL 4 (EL 4)

👉 **Zombies** (6): hp 16 each; see *Monster Manual* page 191.

APL 6 (EL 6)

👉 **Large Zombies** (6): hp 29 each; see *Monster Manual* page 191.

Tactics: The zombies will shuffle forward and attack mindlessly. The ghouls in B1 will hear any combat and prepare to ambush the players. If any players break through the zombies and try to flank them, the ghouls will jump out from behind and flank the player in return. In this case, a Listen check (DC 17) is required to avoid being caught flat-footed by the ghouls.

B1 –

Opening the door reveals a 10-foot by 10-foot side room, as barren as the main room.

If the ghouls did not join the melee in B, add the following:

The stench of death is magnified in this small room. As you peer in, the source becomes apparent as several thin, reeking creatures, with filth caked claws leap at you from the darkness.

Creatures: Several ghouls stay here. They don't like to mingle with the Zombies so they stay in this room.

APL 2 (EL 2)

👉 **Ghouls** (2): hp 13 each; see *Monster Manual* page 97.

APL 4 (EL 3)

👉 **Ghouls** (3): hp 13 each; see *Monster Manual* page 97.

APL 6 (EL 4)

👉 **Ghouls** (4): hp 13 each; see *Monster Manual* page 97

Tactics: If the ghouls do not ambush the party during the battle in B, they will leap at them as soon as they enter

this room. A Spot check (DC 17) is required to avoid being caught flat footed.

C –

A 30-foot long passage leads down to a pair of double doors.

Development: The doors are locked.

🔍 **Wooden Doors:** 2 in. thick; hardness 5; hp 20; AC 5; Break DC 25; Open Lock DC 22.

D – If the players enter from the north:

The double doors swing open revealing a 10-foot by 30-foot room. Another set of double doors stands 10 feet across from you.

If the party enters from the secret door on the east:

A 10-foot wide room stretches out 30 feet in front of you. Halfway along the north and south sides, double doors stand closed.

A number of humanoids are standing around in the room. At first you wonder if they are simply unaware of your presence, but they suddenly turn as one and lurch toward you. As they do, a stench of death rolls off of them making your stomachs turn.

Development: Both sets of double doors are locked. The east and west walls both have secret doors in them.

🔍 **Wooden Doors:** 2 in. thick; hardness 5; hp 20; AC 5; Break DC 25; Open Lock DC 22.

🔍 **Secret Doors:** Search (DC20).

Creatures: More zombies stand guard here.

APL 2 (EL 3)

👉 **Zombies** (4): hp 16 each; see *Monster Manual* page 191.

APL 2 (EL 5)

👉 **Zombies** (8): hp 16 each; see *Monster Manual* page 191.

APL 3 (EL 6)

👉 **Large Zombies** (6): hp 29 each; see *Monster Manual* page 191.

E. – Strange carvings and writings are on the walls of this wide hallway. They depict a black formless creature with yellow eyes sitting under a beautiful tree. There are skeletal hands reaching up from the ground. At the far end of the corridor another set of double doors bars your way.

F –

The secret doors leads to a winding passage that ends in blank wall. Halfway along the passage, a door leads off to the west.

Development: A secret door can be located at the end of the passage.

🔍 **Secret Door:** Search (DC20).

Development: The side door leads to a corridor west. Two doors lie along the corridor, one to the north and one at the end. If the door to the north is opened, read the following;

The door is unlocked and opens on a 10 foot by 20-foot room. A foul stench wafts out as you open the door.

Despite the ominous stench, the room is unoccupied. Several shelves within are filled with rotting foodstuffs.

F1 –
The door to this room is both locked and trapped.

🔨 **Wooden Doors:** 2 in. thick; hardness 5; hp 20; AC 5; Break DC 22; Open Lock DC 22.

🦋 **Poison Needle Trap:** CR 2; +8 melee (1+ greenblood oil poison); Search (DC22); Reflex save (DC20) avoids; Disable Device (DC20).

Greenblood Oil: Injury (DC13); Initial Damage: 1 Con; Secondary Damage: 1d2 Con.

Having finally defeated the door, you look inside and see a 10-foot by 20-foot room with a small box on the floor.

The box is open, and contains a small store of treasure.

Treasure: 500 gp, two rubies at 100 gp each; Silver Masterwork Dagger

G –
*A circular room, 20 feet in diameter opens before you. In the center of the room is a crude altar covered in old bloodstains. A dagger sits on top of the altar.
A lone zombie lurches toward an opening in the south wall. In its hands, it carries the girl from the village, dead or unconscious.*

Development: A secret compartment (Search roll DC 20) contains an unholy symbol. A Knowledge (Religion) check at DC 20 will reveal it as a symbol of Nerull.

Creatures: One zombie carries the missing girl toward the tunnel leading into the woods.

🧟 **Zombies (1):** hp 16; see *Monster Manual* page 191

H –
A twisting tunnel leads from the well off to some unknown destination.

Development: If the PCs follow the tunnel – Go To Encounter 7.

If not, Go to Encounter 6.

ENCOUNTER 6: THE BARTENDER AND THE SCOUT

The townspeople are very happy that you've done a good deed for the town (whether it was saving the girl OR fighting the orcs).

An older man with a hobbled leg walks up to your group. Behind him is a young boy dressed in animal pelts.

“My name's Tekel. I tend bar at the Sapling Inn. Many thanks for your help, drinks are on the house for you guys!!! By the way, there was a group like yours, adventurers I mean, that was in town a few weeks ago. They said they were heading into the Forest to find some sort of treasure.”

He motions to the boy.

“They hired Silent Wolf to help them find their way. He took them a way in but stopped at a certain point. It didn't feel right to him.”

Tekel moves closer as does Silent Wolf:

“I think they got something to do with all the funny stuff that's been going on.”
Silent Wolf nods in agreement.

Development: Silent Wolf will gladly take them to the spot where he left the other group of adventurers if they ask him. Silent Wolf is a human Ranger. He is unable to speak for some reason, which obviously he can not discuss.

🐺 **Silent Wolf, male human Rgr4.**

ENCOUNTER 7: THE OWLBEAR

*The forest is strangely quiet. The trees and plants are dark, black and filled with decay. The canopy is dying, and light is streaming down to the forest floor. But the ground layer isn't thriving the way it should. No new plants are springing up with the suddenly abundant light. There is also a peculiar silence in the air. Even the insects appear to be gone, as none are swarming you as they normally would at this time of year.
Suddenly, a piercing shriek rips the air, and a furry, clawed nightmare leaps upon you.*

As the party moves through the Dreadwood, either following the trail from the well or following the mute ranger Silent Wolf, the owlbear that has been plaguing the region attacks them. At APL 4 there are two owlbears, and at APL 6 there are four.

Creatures: One or two owlbears.

APL 2 (EL 4)

🦉 **Owlbear:** hp 47; see *Monster Manual* page 148.

APL 4 (EL 6)

🦉 **Owlbear** (2): hp 47 each; see *Monster Manual* page 148.

APL 6 (EL 8)

🦉 **Owlbear** (4): hp 47 each; see *Monster Manual* page 148.

ENCOUNTER 8: THE RIDDLE

After a hike through the decaying woods, a worn path shows between two trees. The path twists and turns, and after a few minutes you see a very small clearing ahead. There is some kind of marker in the middle.

If Silent Wolf is with the party, he will point at the marker to indicate this is where he left the other party. He will then turn and head back down the trails.

Development: The marker is a tombstone above the Crypt of Thestos. Upon it is a riddle that allows entry to the crypt below. If the riddle cannot be solved, the party can search for the secret door instead. However, it is trapped, and opening the lock without answering the riddle will trigger the trap.

🔒 **Secret Door:** Search (DC 30), Open Lock (DC30).

🦋 **Acid Spray Trap:** CR 1; +10 ranged (2d6); Reflex save (DC 20) avoids; Search (DC 20); Disable Device (DC20).

Riddle

Water and Earth
They mix together

It sounds like that above

When you know
The word will flow

Then place it in the Glove

ANSWER:

Water and Earth
They mix together
(Mud)

It sounds like that above
(The answer rhymes with mud)

When you know
The word will flow
(say BLOOD out loud)

Then place it in the Glove

(A stone hand emerges from the tombstone. It is open, palm up. Must put drops of blood into palm for door to unlock.)

The steps lead down to Encounter 9.

ENCOUNTER 9: THE CRYPT OF THE EVIL CLERIC

Development: Due to the cursed nature of this place, all turn checks against the undead are made at a –2 penalty.

A –

The stairs lead down to a 10-foot by 30-foot antechamber with murals on the wall depicting an army of undead, razing villages, killing people and destroying temples of good. There is a door is on both the east and west walls.

Development: There is a secret door on the south wall opposite the entrance. The switch can be found on the upraised arm of a villager being slaughtered in one of the murals.

🔒 **Secret Door:** Search (DC22).

B –

A 20-foot by 15-foot guardroom with a sturdy door on the south wall.

Development: The door is locked. If the party is delayed in opening it, the undead in D will have joined Naxalon Fenn in M.

🔒 **Wooden Doors:** 1 in. thick; hardness 5; hp 10; AC 5; Break DC 18; Open Lock DC 20.

C –

A 20-foot by 15-foot guardroom with a sturdy door on the west wall.

Development: The door is locked. If the party is delayed in opening it, the undead in J will have joined Naxalon Fenn in M.

🔒 **Wooden Doors:** 1 in. thick; hardness 5; hp 10; AC 5; Break DC 18; Open Lock DC 20..

D –

A locked door bars your passage forward.

🔒 **Wooden Doors:** 1 in. thick; hardness 5; hp 10; AC 5; Break DC 18; Open Lock DC 20.

Development: When the party has opened the door, read the following;

As the door opens into a 20-foot by 20-foot guardroom, a horde of animated skeletons turns and charges you.

Note: If the party went through rooms B and J first, these skeletons will not be here, having joined Naxalon Fenn in M.

The door on the south wall is locked like the first door.

Creatures: A pack of Skeletons stand guard here.

APL 2 (EL 2)

☞ **Skeletons** (3): hp 6 each; see *Monster Manual* page 165.

APL 4 (EL 4)

☞ **Skeletons** (6): hp 6 each; see *Monster Manual* page 165.

APL 6 (EL 6)

☞ **Skeletons** (10): hp 6 each; see *Monster Manual* page 165.

E –

A small bloodstained altar sits in the middle of this 10-foot diameter room. A dagger sits on the Altar.

Development: A secret door is on the east wall.

🔑 **Secret Door:** Search (DC20).

F –

The passageway twists and turns, and ends in a sturdy door like the others throughout this tomb.

Development: The door at the end of the passage is a false door.

G –

A locked door bars your passage forward.

🔨 **Wooden Doors:** 1 in. thick; hardness 5; hp 10; AC 5; Break DC 18; Open Lock DC 20.
When the door is opened, read the following;

This 20-foot by 10-foot room is covered with murals of undead armies. A door lies opposite the one you entered, and another is in the middle of the south wall.

Development: The door to the south is locked. If the party tries to open either door, the ghouls from H attack them.

H –

This side door opens onto a 10-foot by 10-foot guardroom. A pack of ghouls pours out and attacks you as you deal with the door.

Development: If the players are opening the door to I, the ghouls attack them from behind. Otherwise they simply charge them as the party reveals their den.

Creatures: A pack of ghouls waits here for the party to enter.

APL 2 (EL 2)

☞ **Ghouls** (2): hp 13 each; see *Monster Manual* page 97.

APL 4 (EL 3)

☞ **Ghouls** (3): hp 13 each; see *Monster Manual* page 97.

APL 6 (EL 6)

☞ **Ghouls** (4): hp 13 each; see *Monster Manual* page 97.

Tactics: The ghouls will attack if disturbed or if the door to I is opened.

I –

You open the door and reveal a 10-foot by 20-foot room. In the center, a palpable wave of Evil radiates from an open sarcophagus. Inside it, the warped and desiccated body of what might have been a man lays exposed.

Aura of Evil: Anyone entering the room must make a Will save (DC16) or run away for 2d4 rounds.

The body of Thestos will mentally call the rest of the undead to help him against the adventurers. Any undead not already destroyed will answer the call.

The body can *only* be destroyed if it is stabbed through the heart with one of the three daggers found at the altars either in Oakroot or here in the Crypt. This would be the “Blessed Blade of an Evil Man” that the Old Woman makes reference to in Encounter 3.

If the PCs are unable to destroy the body, Thestos will have zombies transport his body through the Secret Door. He will guide them to another hidden complex in the Dreadwood where he can be concealed once again.

If the PCs do destroy the body, the rest of the undead will fall, inert, to the ground.

If the PCs destroy the undead and bring the body to the surface, Vaylenn Moonchild and the Dreadwalkers will be waiting. They will take care of the body.

J –

Creatures: 4 skeletons and 2 ghouls are stationed here.

ALL APL (EL 3)

☞ **Ghouls** (2): hp 13 each ; see *Monster Manual* page 97.

☞ **Skeletons** (4): hp 6 each; see *Monster Manual* page 165.

Tactics: The ghouls will lurk in the northern alcove until the party is engaged with the skeletons and then attempt to surprise them.

K –

A small chamber with a narrow corridor lies behind the secret door.

Development: If the party files down the corridor, read the following:

As you enter the corridor, the floor suddenly gives way beneath you.

This pit is 20 feet long, so up to 4 players could drop into it. If the party comes this way, the undead from both E and J will be with Naxalon Fenn in M.

☞ **Pit Trap (20 ft. deep):** CR 1; no attack roll necessary (2d6); Reflex save (DC20) avoids; Search (DC20); Disable Device (DC20).

L –

A 5-foot wide corridor stretches into the darkness past the pit. Far ahead, and unholy light flickers like a beacon of death.

Development: Players will only be able to pass down this corridor in single file. Note the marching order as it will have a significant effect on combat in the main altar room.

M –

You enter a circular room over 30 feet across. Near the north end, an altar to some unspeakable being rises out of the floor as though thrust from below by some massive force. A bloodstained dagger sits upon the altar.

A man is standing at the far end of the chamber as you enter. He turns, and speaks unholy syllables, unleashing a wave of foul energy.

Note: Depending on which way the party entered, there will be undead waiting in the room. Adjust the above description to include them.

This is the main altar room. Unlike the other altars, this one is dedicated to some unknown being, not Nerull. A Knowledge (Arcana), (Geography), (Local), or (Religion) check (DC25) will reveal that it is something forbidden by Keoish law, but no positive identification will be possible.

Creatures: Naxalon Fenn is at the main altar. Undead from E or J will be with him depending on which way the party went.

☞ **Naxalon Fenn:** See NPC summary in the Appendix.

CONCLUSION

When the PCs emerge from the Crypt, Vayllen Moonchild and the group of Dreadwalkers will arrive sent here by their superiors to investigate the temple. The PCs already beat them to it.

You see a group of figures in green and brown cloaks riding toward your group.

An elf strides forward, his face stern and set.

“Hail and well met good people. It looks as though you may have an interesting tale to tell. Let us hear it and we will tell you one in return.”

He motions to the others, and they move up to listen as the players speak.

Vaylenn will listen closely to the player's story. He will ask any questions you feel appropriate to elicit all information about what the players discovered in both the well and the temple. He will ask if all undead and any humans were slain. He will also ask if the party talked with any of the humans, and what if anything was said.

Warning!

The Dreadwalkers have full authority in Keoland to imprison or execute anyone dealing with Forbidden magic. The body of Thestos, and indeed the very existence of the crypt is covered by these laws. Players that refuse to cooperate or become difficult will be given one chance to change their ways. After that, they will be imprisoned and all treasure from this adventure confiscated. They will be held for 4 TU while magic is used to interrogate them and confirm their actions and intentions. If anyone wishes to protest further, the Dreadwalkers will have them executed.

Vaylenn will also want to examine all items taken from the well and the crypt. He will insist on taking the daggers found on the altars as well as the holy symbols. If the party has cooperated fully, he will give them the full *Player's Handbook* value (not half) for them. If the party was only partially cooperative he will only offer the standard half value for them. If they were uncooperative, he will confiscate them and threaten them with imprisonment if they persist.

When the players have finished with their story Vaylenn will tell them that the Dreadwalkers are charged with making sure places like this are kept secret. He asks that the players all swear not to reveal what they found here under any circumstances. Anyone that refuses will not be eligible to receive the Influence point from the Dreadwalkers. (Note: The Dreadwalkers do understand duty. Anyone who is obligated to report their actions will be given some leeway. This includes people who are squiring to the Knights of the Watch who will still have to swear only to report and encounter with the Dreadwalkers and have their superiors confirm this by contacting the Dreadwalkers. It will also allow clerics to make general reports to their superiors, but they may not discuss the details.)

After the stories have been exchanged, Vaylenn bids the PCs goodbye. The PCs can now return to Oakroot and the caravan for the second part of the adventure.

The End

EXPERIENCE POINT SUMMARY

To award experience for this adventure, add up the values for the objectives accomplished. Then assign the discretionary roleplaying experience award. The roleplaying award should be given for consistent character portrayal and contribution to the fun of the game. You can award different roleplaying amounts to different characters.

Award the total value (objectives plus roleplaying) to each character.

Encounter Fiv

Killing the zombies in B & D	25 xp each
Killing the ghouls in B1	25 xp
Defeating the trap in F1	25 xp
Saving the girl	25 xp

Encounter Seven:

Killing the owlbears	50 xp
----------------------	-------

Encounter Eight:

Solving the riddle	25 xp
--------------------	-------

Encounter Nine:

Destroying the skeletons in D	25 xp
Avoiding the trap at K	25 xp
Destroying the ghouls in H	25 xp
Destroying the undead in J	50 xp
Destroying the body of Thestos in I, Or delivering it to the Dreadwalkers	50 xp
Defeating Naxalon Fenn in M	75 xp

Total experience for objectives	450 xp
Discretionary roleplaying award	0-50 xp
Total possible experience	500 xp

TREASURE SUMMARY

Player characters may keep items from the scenario that are listed on the treasure list below or which meet the following conditions:

The item must be non-magical and specifically listed in the text of the adventure (e.g armor on foes). If it is not listed in the text, the characters cannot keep it. Items of this nature can be sold for 50% of book value, or recorded on a log sheet.

Animals, followers, monsters, henchmen, and so forth (any living being, basically) may not be kept from a scenario for any reason unless the treasure summary lists the being specifically. It is okay for the player characters to form relationships with NPCs, but these will not be certified and cannot bring material benefit to the character. Contacts (sources of extra information) must be specifically certified.

Theft is against the law, but may be practiced by some player characters. Items which are worth more than 250 gp that are of personal significance to the owner (including family heirlooms), and all magical items, will be discovered in the possession of the character by one means or another. The character must return the item and pay a fine equal to three times the value of the item stolen. In addition, the PC caught receives campaign-decided penalties for being known as a thief. For other stolen items which meet the criteria in #1 above, use your judgment and the circumstances within the game to determine whether a PC thief gets away with the theft or not.

Any item retained according to these rules, which does not have a certificate, will not ever have a certificate issued for it.

The campaign staff reserves the right to take away any item or gold acquired for things that it later finds unreasonable but which were allowed at the time.

Encounter Three

- Boon or Curse of the Rhennee +2 or -2 on all saves for the next three adventures.

Encounter Five

- 500 gp
- two rubies at 100 gp each
- Silvered Masterwork Longsword (375 gp)
- Unholy symbol of Nerull (1 gp)
- Dagger (special) (2 gp)

Encounter Nine:

- light mace (5 gp)
- large steel shield (20 gp)
- chain mail shirt (100 gp)
- belt pouch (1 gp)
- unholy symbol of Nerull (1 gp)

Conclusion

- Adjusted value for the special daggers and the unholy symbols
- Influence: Influence Point with Dreadwalker

DM'S AID 1: NPC COMBAT STATS

MAJOR NPCS

➤ **Naxalon Fenn, male human Clr5:** Medium-size humanoid (human); HD 5d8+16; hp 44; Init +4; Spd 30 ft.; AC 17 (touch 11, flat-footed 16); Atks +4 melee (1d6+1, light mace); AL NE; SV Fort +6, Ref +2, Will +7; Str 12, Dex 12, Con 14, Int 10, Wis 16, Cha 12.

Skills and Feats: Concentration +10, Diplomacy +10, Knowledge (religion) +5, Heal +7, Spellcraft +3; Combat Casting, Improve Initiative, Spell Focus (necromancy).

Possessions: light mace, large steel shield, chain mail shirt, belt pouch.

Spells prepared (5/5/4/3; vane DC 13 + spell level): 0th - *detect magic, light, cure minor wounds, purify food and drink, mending*; 1st - **cause fear, divine favor, doom, bane, entropic shield*; 2nd - *bull's strength, *death knell, hold person, spiritual weapon*; 3rd - *contagion, deeper darkness, *magic circle against good*

*Domain spell. *Domains:* Death (Death touch 1/day. Make a normal melee touch attack. Roll 5d6 for damage. If this at least equals the targets hit points it dies.); Evil (cast Evil spells at +1 caster level.)

Notes: The Evil Cleric, Thestos, is giving Naxalon a portion of his power. His spells will act as if cast by a 7th level cleric, evil spells as 8th level cleric.

DREADWALKERS:

➤ **Vayleran Moonchild, male elf Rgr5:** Medium-size humanoid (elf); HD 5d10 +5; hp 39; Init +4; Spd 30 ft.; AC 18 (touch 14, flat-footed 14); Atks +8 melee (1d6+2/19-20, short sword), +9 ranged (1d8/x3, longbow); SA - Favored enemy (giants +2, beasts +1); AL NG; SV Fort +5, Ref +5, Will +3; Str 14, Dex 18, Con 12, Int 10, Wis 14, Cha 8.

Skills and Feats: Hide +12, Move Silently +12, Spot +10, Wilderness Lore +10; Weapon Focus (short sword), Point Blank Shot, Track, Two-Weapon Fighting, Ambidexterity.

Possessions: Short sword, chain mail shirt, backpack, cloak, waterskin x2, belt pouch, bedroll.

Spells Prepared (1, base DC = 12 + spell level): 1st - *entangle*.

➤ **Dreadwalkers, male elf War3 (5):** Medium-size humanoid (elf); HD 3d8 + 3; hp 21; Init +7; Spd 30 ft.; AC 18 (touch 12, flat-footed 16); Atks +6 melee (1d8+2/19-20, longsword), +6 ranged (1d8/x3, longbow); AL CG; SV Fort +5, Ref +3, Will +1; Str 14, Dex 16, Con 12, Int 13, Wis 11, Cha 10.

Skills and Feats: Climb +8, Jump +8, Listen +3; Weapon Focus (longsword), Improve Initiative

Possessions: Longsword, chain mail shirt, large steel shield, backpack, cloak, waterskin x2, belt pouch, bedroll.

➤ **Silent Wolf, male human Rgr4:** Medium-size humanoid (elf); HD 4d10+10; hp 38; Init +2; Spd 30 ft.; AC 16 (touch 12, flat-footed 14); Atks +6 melee (1d8 + 2/19-20, longsword), +7 range (1d8/x3, longbow); AL CG; SV Fort +6, Ref +4, Will +2; Str 14, Dex 16, Con 14, Int 10, Wis 12, Cha 10.

Skills and Feats: Hide +10, Move Silently +10, Spot +8, Wilderness Lore +8; Weapon Focus (longsword), Off-hand Parry, Track, Two-Weapon Fighting, Ambidexterity.

Possessions: Longsword, chain mail shirt, large steel shield, backpack, cloak, waterskin x2, belt pouch, bedroll.

Spells Prepared (1, Save DC - 12 + spell level): 1st - *entangle*.

ENCOUNTER 2

➤ **Grifo:** Male human Exp3.

➤ **Drivers:** Male human Com1.

ENCOUNTER 3

➤ **The Old Woman, Tula:** Female human Sor5/Vetha2.

➤ **Lana:** Female human Sor3.

➤ **Stilgo:** Male human Ftr4.

➤ **Rhennee Men (7):** Male human War1.

➤ **Rhennee Children (5):** Male and female humans Com1.

Map I: Evil Cleric Crypt

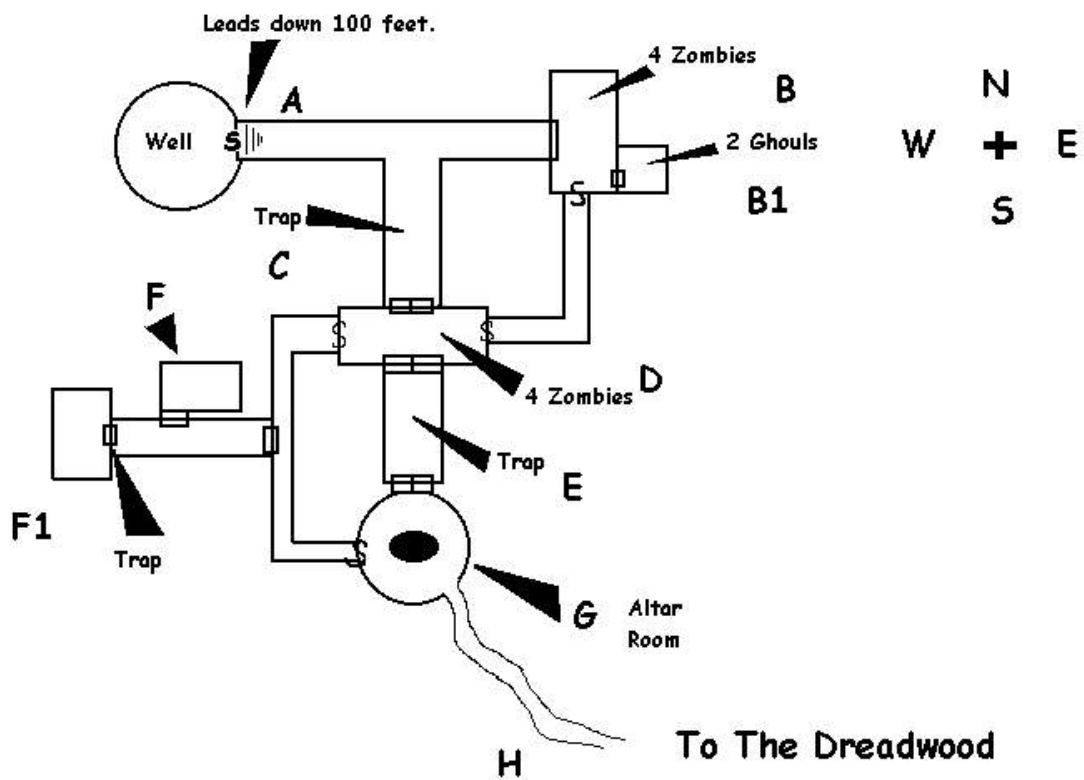

Map #2: Oakroot Zombie Well

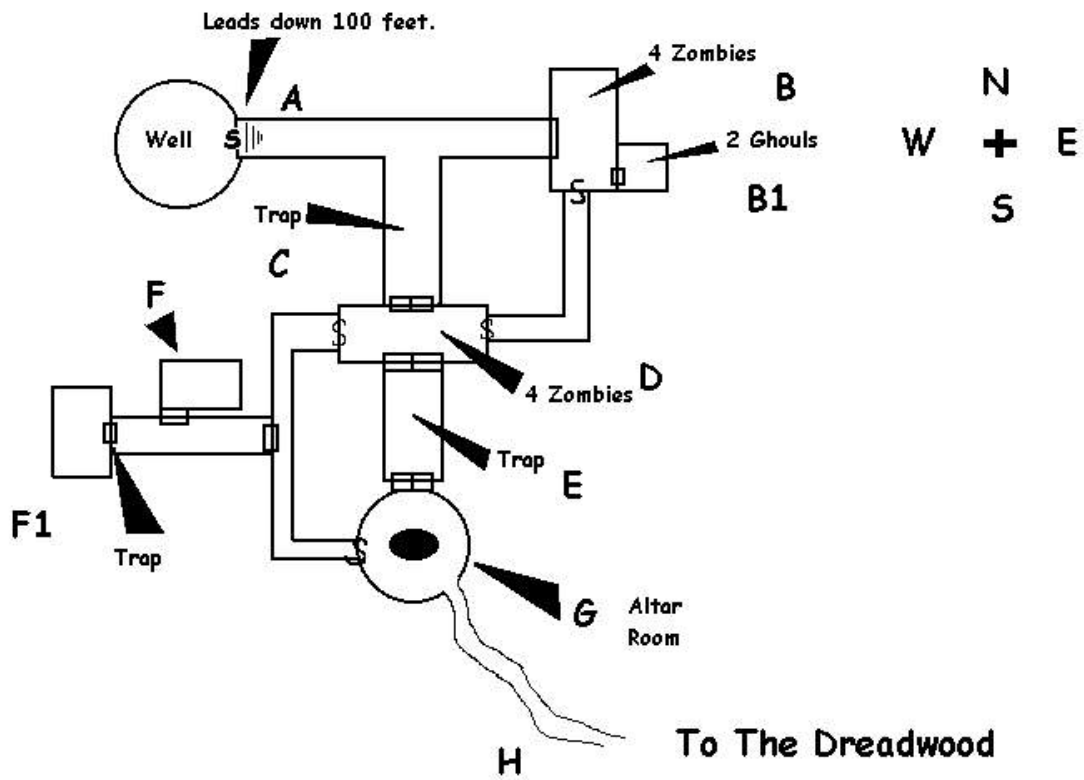

KEO1-06

EVIL IN THE WOODS

A One-Round D&D LIVING GREYHAWK[®]

Keoland Regional Adventure

Version 1

ROUND 2

by Jeffrey Cuttler and Sean Duff

An evil orc warlord threatens the safety of the local town you just saved. Can you save this sleepy village twice in the same week? An adventure for characters level 1-6.

DUNGEONS & DRAGONS, D&D, GREYHAWK and RPGA are registered trademarks of Wizards of the Coast, Inc. LIVING GREYHAWK is a trademark of Wizards of the Coast, Inc. Scenario detail copyright 2001 by Wizards of the Coast, Inc. ALL RIGHTS RESERVED. This scenario is intended for tournament use only and may not be reproduced without approval of the RPGA Network.

This is an RPGA® Network scenario for the Dungeons & Dragons® game. A four-hour time block has been allocated for each round of this scenario, but the actual playing time will be closer to three hours. The rest of the time is spent in preparation before game play, and scoring after the game. The following guidelines are here to help you with both the preparation and voting segment of the game. Read this page carefully so that you know and can communicate to your players the special aspects of playing an RPGA scenario.

PREPARATION

First you should print this scenario. This scenario was created to support double-sided printing, but printing it single sided will work as well. There is enough room along the inside margin to bind the adventure, if you desire.

Read this entire adventure at least once before you run your game. Be sure to familiarize yourself with any special rules, spells, or equipment presented in the adventure. It may help to highlight particularly important passages.

When you run an RPGA D&D adventure we assume that you have access to the following books: the *Player's Handbook*, the *Dungeon Master's Guide*, and the *Monster Manual*. We also assume that you have a set of dice (at least one d4, d6, d8, d10, d12, and d20), some scrap paper, a pencil, an RPGA scoring packet, and your sense of fun. It is also a good idea to have a way to track movement during combat. This can be as simple as a pad of graph paper and a pencil, as handy as a vinyl grid map and chits, or as elaborate as resin dungeon walls and miniatures.

Instruct the players either to prepare their characters now, or wait until you read the introduction, depending on the requirements of the scenario as described in the introduction.

Keep in mind that you must have at least four players (not counting the DM), for the game session to be a sanctioned RPGA event. As well, you cannot have more than seven players participating in the game.

Once you are ready to play, it is handy to instruct each player to place a nametag in front of him or her. The tag should have the player's name at the bottom, and the character's name, race, and gender at the top. This makes it easier for the players (and the DM) to keep track of who is playing which character.

The players are free to use the game rules to learn about equipment and weapons their characters are carrying. That said, you as the DM can bar the use of even core rule books during certain times of play. For example, the players are not free to consult the *Dungeon Master's Guide* when confronted with a trap or hazard, or the *Monster Manual* when confronted with a monster.

Some of the text in this scenario is written so that you may present it as written to the players, while other text is for your eyes only. Text for the players will be in gray boxes. It's strongly recommended that you paraphrase the player text instead of reading it aloud. Some of this text is general and must be adapted to the specific situation or to actions of the player characters.

SCORING

After the players have completed the scenario or the time allotted to run the scenario has run out, the players and DM score the game. The RPGA has three ways to score its games. Consult your convention coordinator to determine which method to use for this scenario:

4. No-vote scoring: The players write their names and RPGA numbers on the scoring packet grid. You fill in the top of the grid. That is all. No one is rated. This method is used for people who are just playing for fun.
5. Partial scoring: The players rate the game master and the scenario on their player voting sheet, and provide personal information, but don't vote for other players. The game master rates the scenario and completes personal and event information, but does not rate the players as a team or vote for players. This method is used when there is no competition, but the event coordinator wants information on how the game masters are performing, or the game master wants feedback on his or her own performance.
6. Voting: Players and game masters complete the entire packet, including voting for best player. If this method is used, be sure to allow about 15-20 minutes for the players to briefly describe their characters to the other players, and about 5-10 minutes for voting. This method is used when the players want to know who played the "best" among the group, or when the adventure is run in tournament format with winners and prizes.

When using voting, rank the players in order of your voting choice while they are completing their forms, so that you are not influenced by their comments on your abilities. It's a good idea to have the players vote while you determine treasure and experience awards for the scenario.

After voting, give the Scoring Packet to your event coordinator.

This is a LIVING GREYHAWK Adventure. As a Living™ adventure, it is expected that players will bring their own characters with them. If players do not have a LIVING GREYHAWK character generated, get a copy of the current LIVING GREYHAWK character generation guidelines, a character sheet, and a LIVING GREYHAWK log sheet from your convention coordinator or the RPGA Web site, and then have any players without a character create one. Once all players have a LIVING GREYHAWK character, play can begin.

Along with the other materials that you are assumed to have in order to run a D&D game, it is also recommended that you have a copy of the LIVING GREYHAWK *Gazetteer*.

DETERMINING AVERAGE PARTY LEVEL (APL)

Because players bring their own characters to LIVING GREYHAWK games, this adventure's challenges are proportioned to the average character level of the PCs participating in the adventure. To determine the Average Party Level (APL):

- 5) Determine the character level for each PC participating in the adventure.
 - 6) If PCs bring animals that have been trained for combat (most likely war horses, dogs trained for war), other than those brought by virtue of a class ability (i.e., animal companions, familiars, paladin's mounts, etc.) use the following chart to determine the number of levels you add to the sum above. Add each character's animals separately. A single PC may only bring four or fewer animals of this type, and animals with different CRs are added separately.
- | CR | 1 | 2 | 3 | 4 |
|-------------|---|---|---|---|
| 1/4 and 1/6 | 0 | 0 | 0 | 1 |
| 1/3 and 1/2 | 0 | 0 | 1 | 1 |
| 1 | 1 | 1 | 2 | 3 |
| 2 | 2 | 3 | 4 | 5 |
| 3 | 3 | 4 | 5 | 6 |
| 4 | 4 | 5 | 6 | 7 |
- 7) Sum the results of 1 and 2, and divide by the number of characters playing in the adventure—round up.
 - 8) If you are running a table of six PCs, add one to that average.

By following these four steps, you will have determined the APL. Throughout this adventure, APLs categorize the level of challenge the PCs will face. APLs are given in even-numbered increments. If the APL of your group falls on an odd number, ask them before the adventure begins whether they would like to play a harder or easier adventure. Based on their choice, use either the higher or the lower adjacent APL.

APL also affects the amount of experience you may gain at the end of an adventure. If your character is three character levels or more either higher or lower than the

APL that this adventure is played at, that character will receive only half of the experience points awarded for the adventure. This simulates the fact that either your character was not as challenged as normal, or relied on help by higher-level characters to reach the objectives.

Note: LIVING GREYHAWK adventures are designed for APL 2 and higher. Three or four, or sometimes even five 1st-level characters may find difficulty with the challenges in a LIVING GREYHAWK adventure. If your group is APL 1 there are three things that you can do to help even the score.

- 4) Attempt to create a table of six 1st-level characters, or try to enlist higher-level characters to play at that table.
- 5) Advise characters to buy riding dogs to help protect them, and fight for them. All riding dogs are considered trained to attack. PCs who want their dog to attack they must succeed at a Handle Animal or Charisma check (DC 10). Failure indicates that the animal will not attack that round. This is a free action (spoken command) that may be attempted each round. If an animal loses half or more hp in a single round it flees, unless another check is successful.
- 6) A group of APL 1 adventurers who desire an extra hand can "enlist an iconic." The stats for the 1st-level versions of Tordek, Mialee, Lidda and Jozan are given at the end of each adventure. The group may pick one of these characters to joint them on this adventure. The DM controls that NPC.

If you are using a 591 CY adventure (campaign year 1) that uses the old APLs, assume that the APL multiplied by 2 is the APL suitable for that encounter.

IS IT A FULL MOON?

Since the hazards of lycanthropy are a current part of the LIVING GREYHAWK campaign, it may be necessary to determine if this adventure takes place during a full moon. For game purposes, the full moon lasts three days of each month. For a given scenario that does not state the phase of the moon, roll 1d10 before play begins. On a result of 1, the first day of the scenario is a night of the full moon (roll 1d3 to determine where in the sequence of three nights it falls).

LIFESTYLE

At the beginning of every scenario, each PC is required to pay upkeep costs matching the level of lifestyle they wish to maintain. The lifestyles, and the effects that each has on play, are:

Destitute: You have no living space, and must carry all your gear everywhere. You eat poor quality food. You wear a peasant outfit, your only change of clothes.

Poor: You sleep in poor accommodations, and eat poor quality food. You wear a peasant outfit, and have two sets of clothing.

Common: You have common lodgings, and eat common quality food. You have normal clothing for your profession (adventuring); nothing fancy. You probably have two or three sets of clothing.

High: You stay in good quality lodgings, and eat good quality food. You wear anything in value up to courAPL's outfits, and generally buy a new set of clothing every two weeks.

Luxury: You have luxurious accommodations (twice the cost of good accommodations), and you eat excellent foods. You can throw a banquet for your friends every day, and frequently do. You wear clothing up to the value of noble's outfit, and buy a new set of clothes every week.

Lifestyles come with bonuses or penalties to Diplomacy, Intimidate, Disguise, and Bluff skill checks. These penalties, shown below, should be applied at the DM's discretion, and can sometimes backfire—for example, a PC with a poor lifestyle would not have a penalty when talking to a beggar, but would when talking to a city official. A PC with a high lifestyle should have a penalty when dealing with a group of street thugs, where a PC with a destitute lifestyle might not.

DMs are encouraged to role-play these reactions whenever possible.

Lifestyle Cost	Skill Modifier	
Destitute	14 sp	-2
Poor	43 sp	-1
Common	12 gp	0
High	250 gp	+1
Luxury	500 gp	+2

Adventure Summary and Background

This portion of the module will take place after the PCs have taken care of the threat from the evil temple. As the PCs return from there, victory in the evil temple a second problem presents itself to Oakroot. The second half of this module is strictly a dungeon crawl with variable options to solve. A powerful orc warlord will now have free reign of the region with out the zombies to quell his lust for conquest. The PCs will be asked by both the Dreadwalkers and the town of Oakroot to deal with the threat.

As the PCs return from the temple to the sleepy town of Oakroot a caravan that was pulling into town comes under attack.

Encounter I: The Caravan is Under Attack!

As you return from your journey with the young girl in tow. A man runs into the Center Square and yells. "The village is under attack. The west side! Orcs! Orcs! Orcs! The west side!" He continues to run and yell out the same message.

Give PCs a moment to react then read the following

The west side of town rings out with the sounds of battle. The Caravan is being attacked from the front and the back. You can see a (description depends on APL PCs play at.) two groups of humanoids at the front AND the back of the Caravan. Workers are attempting to defend themselves, but several already lie still on the ground. What do you do?

Each group depends on APL.

At APL 2, there are no ogres and there are two bands of six orcs attacking the caravan. At APL 4 its a single ogre attacking the lead of the wagon paired with one group of six orcs, the rear guard consists of just six orcs. At APL 6 there is an ogre with each group of six orcs.

In 4 combat rounds, a group of Dreadwalkers enters the fight.

Suddenly a group of figures in green and brown cloaks enter the area of the fight. They swarm out of the Forest and attack the orcs and ogres.

They go after the group that the PCs are not handling. If the PCs split up, make the Dreadwalkers split as well.

After the battle is over, the Dreadwalkers regroup and address the PCs. An Elven male strides forward. Dressed in greens and browns, he wears leather armor with a pair of short swords by his side and a longbow strapped to his back. Silver hair frames a stern face with silver eyes.

"I am Vaylenn Moonchild, leader of the Dreadwalkers in this area." Bowing slightly a look of recognition of your group as the heroes that defeated the evil cleric he chuckles and speaks "You beat us to it again. Your help was appreciated in destroying these foul enemies of the forest. However, I'd like to know your intentions in our Forest."

He waits for the PCs to respond. In the middle of the PCs explanations he abruptly turns and suddenly barks "You" and points at one of the PCs. "Speak truly! Are you Friend or Foe of the Forest?" He waits for a reply and points again "And you?" He asks all the PCs if they are friend or foe. If any of the PCs says "Foe" Vaylenn will glare at all the PCs, spit on the ground and motion to the Dreadwalkers. They ride off into the forest.

Then the PCs will be asked by the town to save them from the orc threat. And the favor of the Dreadwalkers will be removed.

If they say "Friend" Vaylenn smiles for a moment and continues to speak.

"The Dreadwood is no place for the unwary. The ancient evil, you just defeated is not the only terrible foe that has arisen within this section of the Dreadwood of late. An Orc Warlord is very close by. He is waiting and plotting against all of us. The evil cleric always kept them within the forest; a sort of balance of power, if you will, keeping the orcs deep within the Dreadwood, but the caravan attack shows that with the temple and undead removed the tribe will become bolder. Our travels take us far and wide and we cannot be everywhere at once. We now need to take the body of Traxus to one of our bases for our leaders to deal with. Perhaps you could put a stop to the warlord.

Creatures:

APL 1

👉 **Orcs** (12): hp 4; see *Monster Manual* page 146.

APL 2

👉 **Orcs** (12): hp 7; see *Monster Manual* page 146.

👉 **Ogre** (1): hp 26; see *Monster Manual* page 144.

APL 3

👉 **Orcs** (12): hp 7; see *Monster Manual* page 146.

👉 **Ogre** (2): hp 26; see *Monster Manual* page 144.

Encounter 2: The Towns Request for Help!

After the battle the townspeople of Oakroot will appear.

Returning from dealing with the evil priest and his undead minions as well as rescuing the caravan from the orc assault to the small town of Oakroot, you are greeted with a hero's welcome. A young boy steps forward to tell a poem of your heroics, while blushing maidens wave and give coy smiles to the male members of the group. A small feast is held in your honor as pheasant and venison are served with a strong honey mead. All in all a very pleasant surprise, and a welcome rest after the days events with the cleric and his evil temple.

As the feast winds down a old man clears his throat and turns to you. "Ahem, you have done much for my people these past few days. The town of Oakroot no longer fears constantly since your arrival, you the great heroes that you have become to us. But, we fear you may have sealed our doom with the defeat of the Orc raiding party on the caravan. You see we know that they were merely part of a much larger tribe of orcs within the woods. I fear that this band will come and extract vengeance upon our small village for defeating their numbers. So I ask you this last request, before you all leave. Could you drive the orcish threat to this village away, or destroy them so that we all can live at peace.

Mortimer, the one townsfolk who drew the short straw and was the one who had to ask the PCs is who this fellow is. He is a nervous farmer and he knows the town has nothing to offer the adventurers in monetary reward. The

raids that the orcs have made have already cost them a good deal extra in having to hire caravan guards.

Mortimer said that he and the village had taken a vote and any of the stolen goods that the PCs could find at the cave would be there's as right of the adventure. All the people in the village are worried about is the threat of a vengeful attack being led by the orc's leader. Mortimer is not stupid though, and he knows the things that may peak the adventurer's interest. Rumor has it that Kiol the Insolent, the leader of the orc band wields a magical heavy mace.

Appeal to the heroic nature of the characters, in either case no reward will be offered the PCs. If they demand payment the Dreadwalkers will handle the situation delaying their trip to Niolo Dra and the event will end for the Player characters.

In either case the PCs route to the orc complex will be fairly straightforward. Directions to the general area will be provided and the orcs have never made secrets of hiding from sight, never fearing the Villagers of Oakroot.

Encounter 3: Orc Bashing Dungeon Crawl!

This part of the module can go numerous ways based on what the PCs do to eliminate the threat as they see fit and appropriate. These orcs are a war like band but they know defeat when they see it. If faced with overwhelming odds, they might surrender and leave the area. Play the orc band intelligently not as dumb enemies with no sense of tactics. Sound of battle will attract orcs from elsewhere in the complex. An orc patrol going missing for several hours after they are due back will draw attention, and force a double sized patrol to go out and look. Overall there are 43 orcs at the complex. Eighteen warriors, 12 female orcs, and 5 children. The woman orcs will be treated as noncombatants, unless the children are threatened or attacked.

The Orc Complex

The Patrol- At all times a four-orc squad is on patrol of the forest surrounding the cave. See standard orc statistics in the appendix for details. The orc patrols go on four-hour patrol rotations. If the PCs take a patrol out and do not act before the patrol is due back the orcs will be on full alert in the cave complex. PCs may be surprised by the patrol if not taking careful preparations. Have each side roll a spot check. The side with the higher spot will see the other first. Each patrol has a horn that they will blow that will alert the complex. The patrol will try and deal with PCs themselves first before blowing the horn. The second one of the orc drops if no PC has they will use the horn and flee back to the cave.

Each of the following patrols are broken down by APL. Complete combat stats are located in the appendix.

APL 1

👉 **Orcs** (4): hp 4 each; see *Monster Manual* page 146.

APL 2

➔ **Orc Warriors, mix male and female orcs Ftri (3):** hp 8 each, see Appendix. -

➔ **Orc Barbarian, male orc Bbn2:** hp 20; see Appendix.

APL 3

➔ **Orc Barbarian, male orc Bbn2 (24):** hp 20; see Appendix.

A. The Entryway.

Read the Following if the Complex was not yet alerted.

In front of you a large cave mouth opens from the side of the hill. Smoke and light can be seen coming from inside. A large picket line of crossed spears blocks the entrance and it seems a pair of orcs stand guard bored occasionally glancing out at the forest.

Read the following if the complex is on alert.

Coming to a clearing in the dense forest you can see it has been purposely done. At the other end of the clearing is a large cave with light and smoke coming from its mouth. Across the large entrance is a picketed spear wall, behind it many orcs look out on the clearing occasionally shouting out something in Orcish.

If any PC speaks orc they are saying "Patrol Check in. Patrol what is happening." If an orc from the patrol escaped, the orcs will be calling out taunts and curses toward the PCs.

The entrance to the cave system is fairly easy to spot, the orcs have cleared out a one hundred foot area around the entrance to assure them sight of any incoming enemy. The cave is blocked by a five-foot high spear wall, which will offer the orcs behind it firing arrows, a 25% cover bonus. PCs that charge this will be forced to either climb over, where they will take 2 hp of damage and be denied their Dex bonus against attacks by the orcs behind the wall. At all times there will be two orcs standing duty behind the wall. It only takes five rounds for the whole of the Complex to be alerted and move toward the defense of the cave. The cave mouth is large enough for four orcs to stand abreast and fight. Those guarding the cave and in the front rank will be using longspears, and have a reach attack against any party member charging the entrance. Four longspears are kept at the entrance for use by any orc assigned this duty.

Kiol will hold back until the line is breached at which point he will step forward to engage and attempt to breach the gap, while Grunic casts spells from the rear of the cave.

PCs that can bypass the guards or take them before they can send off the alarm will face a very surprised cave system, unprepared for a breach.

PCs will come up with numerous ways to draw out the guards. None short of a charm or suggestion will cause them to leave. They fear their chieftain to much to disobey his orders.

B. The Main Guard Room

Coming past the guard entrance, you come into a room full of junked weapons and scraps of armor. There are exits east and west of this fifty by forty foot cave. Many crude cave paintings dominate the walls showing Orcs defeating elves in a large battle.

Here is where the orcs place their weapons and armor. Javelins and rusted and ill treated weapons line the walls, as well as piles of ill-fitting armor looted from caravan guards. The orcs in the complex do not keep their spare weapons upon them; instead they leave them at this post. If the PCs can get past the gate guard without alerting the complex they will find a lone orc female in hear whose job it is to help outfit the orcs with the proper equipment. She is old and unarmed but intelligent and will negotiate to save her own life. If she sees the PCs she will scream for help. If captured or threatened in anyway with a weapon, she will hold her tongue and attempt to negotiate her freedom.

Weapons and armor taken from here will hold no value due to the poor quality they have been kept in.

C. Shaman's Chambers

Coming into a smaller cave at the end of a tunnel you can see many more of the crude painting you had seen in the entryway. Varied skulls hang from twine from the ceiling giving the room a ominous feel. A small altar along with a bowl of blood lies in the center. A small pile of hay covered by a old wool blanket sits in one corner and could only be a bed of some kind.

In all 13 skulls hang from the ceiling, ten are human skulls and three are elven. The altar is one to Gruumsh, the orc god. If the PCs have gotten here before the alert they will find Grunic here along with three orc females attending him. Grunic will immediately sound the alarm if able to. Any of the orc women if given a chance will also scream out in request of help.

D. The Main Living Area.

Rounding a corner in the cave system you come to a large cave strewn with rubbish and straw mattresses. Many of the crude drawings that dot the walls are soot covered from the unventilated fires within the room.

If the PCs make it here before causing the complex to go under alert they will find the remaining orc warriors in here. Who will immediately respond and attack. They will have a +1 morale bonus to hit in this area as they are defending the home. The female orcs along with the children will run to the exit and collapse the tunnel behind them, as they will quickly realize that they are in trouble.

PCs that search the cave after the combat is dealt with will find 53 gold pieces, and 210 silver pieces in mixed, though mostly Keoish coinage.

E. Treasure Room.

Stepping around a tunnel you see a heavily locked and chained grate. Beyond the grate you can see a room stuffed with all manner of goods. Many of the goods bear marks of trading companies you have seen on the road in previous days. It would indeed appear you have found the orcs that have been raiding caravans of late.

There are two simple locks to pick (DC 18, DC 16) to open the gate. The gate itself is Hardness 20 with 20 hp made of a strong and thick iron. The chains that circle the gate keeping it closed are hardness 10 hp 10. Inside are a lot of the stolen goods from the missing caravans. There is all manners of stolen foodstuffs (2 Kegs of BlackBeak Ale from Curget, 1 Cask of Wine from the Vineyards in the County of Nume Eor. One box full of Salted beef, another barrel full of hard tack biscuits, and yet another with pickled herring.) There are bolts of normal cloth as well as one bolt of silk. A large wagon with one detached wheel (a Craft (Carpentry) check (DC 12) using the tools can fix this. It can then be loaded with the goods for transport back to Oakroot). There is a collection of fine carpentry tools and a set of large cogs that obviously belong to a mill crank. In all there is 2600 pounds of mundane type treasure. If the PCs can manage to get it back to Oakroot they can receive two hundred and fifty gold pieces for the goods, which were originally meant to make it to the town. PCs will be able to realize this due to a bill of lading still upon the side of one of the crates.

F. Kiol's Cave.

The cave you now peer in is lavish compared to the rest of what you have seen. Carpets lie across the cave floor, while tapestries of various orc victories adorn the wall. There is even a down mattress on a brass frame, full of lace pillows.

Kiol as chieftain has always taken all of the treasure he has seen fit to take, and all this room is what he deemed as his treasure. Being unquestionably the strongest and best warrior among the tribe he never had a challenge of living soft in these surroundings. The two women kept in the prison cells were often brought in here for his entertainment. One told him of the joys of things human, and convinced him to decorate like this.

If PCs manage to get here without setting any alarms or alerting Kiol with the sounds of Battle they are an impressive group indeed. And they will find Kiol alone reading a book, sitting in a high-backed chair.

If the PCs search the room they will find beyond the decorations 12 platinum pieces and 26 silver pieces in a small sack underneath his pillow. If PCs wish they may also return the furniture with them to Oakroot.

ENCOUNTER 4: OH BABY!

G. The prison cell and the collapsed cavern.

Coming to the end of this tunnel you can see that it stops abruptly at a cave in. To your left however is a prison cell

bearing two attractive humans, kept in the garb of Ketite harem girls. One is obviously pregnant.

These two women Hunnie and Runa were captured nearly one year ago and have been slaves to Kiol ever since. One in fact is eight months pregnant with his child (now you know where all the half orcs come from). One, Runa, will be utterly relieved at the freedom provided by the PCs. The other's, Hunnie's, first concern will be Kiol. She will want to know what the PCs have done with him, and if told he has been killed she will break down hysterically crying. Either way before the PCs and the freed woman exit the cavern she will know what happened. The cause of the shock will cause her to go into labor early. The woman will need assistance in giving birth, as an orc baby is larger than a normal human child. (A Heal check (DC 12) will help with the labor.) If there is a lot of time left with the event, and it is suitable for the table, this will be a great roleplaying event for PCs. Lying before them will be many, many bodies of defeated orcs, meanwhile there will be a birth going on in their midst. This could be a lot of fun to play up, so as a DM roll with it and describe what you feel would be appropriate to the maturity level of your table. Use some of the following sayings to add a bit of realism (the author has been through two of these with his wife so he has an idea what they would say.)

**Ow, it hurts please do something help!*

**You killed the father, now you're responsible for its upbringing! (to the most charismatic male)*

**Get away from me before I rip your head off.*

"OWwwwwwww."

Be creative and have fun, do not be overly graphic or disgusting with this encounter. It's a useful roleplaying tool but if no PC is enjoying it, give a brief Heal check and describe the event quickly. From here the PCs are free to return to the town of Oakroot as heroes.

Encounter 5: Oak Root Boys!!!

Returning from the orc complex with two freed slaves and a half-orc infant you cannot wait to find a midwife to stop the crying baby. Having to place the new mother on the back of the wagon loaded with stolen goods. The town hears your coming long before they see you, and a group of curious onlookers come out to see what that wailing cry is coming from the woods. Seeing you leading a wagon back loaded with the stolen goods. A cry of joy goes up from the town only causing the infant's cries to increase.

Eventually a middle-age woman comes running out of the crowd and escorts the mother and new baby to her home. Leaving you in the middle of a rural farming community getting thanked immensely for your actions. The mayor

approaches and makes a announcement "From this day forward you will be forever known as Oak Roots Heroes." with that a cheer goes up and the celebration begins....

At this point the two rounds of evil in the woods is over. Only roleplaying the stories of the orc complex remains. PCs should be loaded down with orcish gear that can be sold in the town. The townsfolk will hope the heroes will give back the stolen goods as most of it will have no value to them anyway.

Experience Point Summary

To award experience for this adventure, add up the values for the objectives accomplished. Then assign the discretionary roleplaying experience award. The roleplaying award should be given for consistent character portrayal and contribution to the fun of the game. You can award different roleplaying amounts to different characters.

Award the total value (objectives plus roleplaying) to each character.

Encounter One

Defeating the caravan raiders 50 xp

Encounter Three

Clearing the Orc Complex 375 xp

Encounter Four

Saving delivering mother 25 xp

Total experience for objectives 450 xp

Discretionary roleplaying award 0-50 xp

Total possible experience 500 xpp

Treasure Summary

Player characters may keep items from the scenario that are listed on the treasure list below or which meet the following conditions:

The item must be non-magical and specifically listed in the text of the adventure (e.g armor on foes). If it is not listed in the text, the characters cannot keep it. Items of this nature can be sold for 50% of book value, or recorded on a log sheet.

Animals, followers, monsters, henchmen, and so forth (any living being, basically) may not be kept from a scenario for any reason unless the treasure summary lists the being specifically. It is okay for the player characters to form relationships with NPCs, but these will not be certified and cannot bring material benefit to the character. Contacts (sources of extra information) must be specifically certified.

Theft is against the law, but may be practiced by some player characters. Items that are worth more than 250 gp that are of personal significance to the owner

(including family heirlooms), and all magical items, will be discovered in the possession of the character by one means or another. The character must return the item and pay a fine equal to three times the value of the item stolen. In addition, the PC caught receives campaign-decided penalties for being known as a thief. For other stolen items which meet the criteria in #1 above, use your judgment and the circumstances within the game to determine whether a PC thief gets away with the theft or not.

Any item retained according to these rules, which does not have a certificate, will not ever have a certificate issued for it.

The campaign staff reserves the right to take away any item or gold acquired for things that it later finds unreasonable but which were allowed at the time.

Encounter Five

- +1 Heavy Mace.
- Heroes of Oak Root. For rescuing the village of Oak Root from multiple threats they have named you town savior.

Appendix 1 Combat Summary

Note- All orcs speak only Orc and Goblin. PCs unable to speak these languages will not be able to question the orcs. Kiol and Grunic both speak common and elven as well as orcish and goblin.

APL 2: ORC COMPLEX

➤ **Kiol the Insolent, male orc Ftr3:** CR 3; Medium-size humanoid (orc); HD 3d10+6; hp 28; Init +0; Spd 20 ft.; AC 17 (touch 10, flat-footed 17); Atks +7 melee (1d8+4/19-20, +1 heavy mace); SQ Darkvision 60 ft., light sensitivity; AL CE; SV Fort +5, Ref +1, Will +1; Str 16, Dex 10, Con 14, Int 9, Wis 10, Cha 12.

Skills and Feat: Spot +5, Listen +4, Hide +2, Intimidate +4; Dodge, Power Attack, Cleave.

Possessions: +1 heavy mace, chainmail armor, large steel shield.

➤ **Grunic Darkeye, male orc Clr2:** CR 2; Medium-size humanoid (orc); HD 2d8+2; hp 18; Init +4; Spd 30 ft.; AC 11 (touch 9, flat-footed 11); Atks +3 melee (1d8+1/x3, longspear); SA Spells, rebuke undead; SQ spontaneous cast of inflict spells, darkvision 60 ft., light sensitivity; SR Nil; AL CE; SV Fort +4, Ref -1, Will +5; Str 12, Dex 8, Con 12, Int 14, Wis 14, Cha 8.

Skills and Feats: Bluff +4, Concentration +6, Heal +6, Knowledge (religion) +3, Sense Motive +4; Combat Casting, Weapon Focus (longspear).

Spells Prepared (4/3+1; base DC = 12 + spell level): 0—*cure minor wounds* (x2), *detect magic, light*; 1st—*cause fear* (x2), *protection from good**, *magic weapon*.

* Domain Spells; Deity: Gruumsh; Domains: War (gain Martial Weapon Proficiency [longspear] and Weapon focus [longspear]) and Evil (cast evil spells at +1 caster level)

Possessions: Leather armor, longspear, wooden holy symbol of Gruumsh.

APL 4: ORC COMPLEX

➤ **Orc Warriors, mix male and female orc Ftr1:** CR 1; Medium-size humanoid (orc); HD 1d10+1; hp 8; Init +0; Spd 20 ft.; AC 15 (touch 10, flat-footed 15); Atks +4 melee (1d8+2, battle axe); SQ Darkvision 60 ft., light sensitivity; AL CE; SV Fort +3, Ref +0, Will -1; Str 15, Dex 10, Con 12, Int 9, Wis 8, Cha 8.

Skills and Feats: Spot 5, Listen 4, Hide 2; Alertness, Weapon Focus (battleaxe).

Possessions: Hide Armor (flea infested, no merchant would purchase), large wooden shield, battleaxe.

➤ **Orc Barbarians, mix male and female orcs, Bbn2:** CR 2; Medium-size humanoid (orc); HD 2d12+4; hp 20; Init +1; Spd 30 ft.; AC 16 (touch 11, flat-footed 15); Atks +6 melee (1d8+3/x3, battleaxe); SA Rage; SQ Darkvision 60 ft., light sensitivity; AL CE; SV Fort +5, Ref +0, Will -1; Str 16, Dex 12, Con 14, Int 9, Wis 8, Cha 8.

Skills and Feats: Spot 5, Listen 4, Hide 2. Alertness.

Possessions: Hide armor (flea infested, no merchant would purchase), large wooden shield, battleaxe.

➤ **Kiol the Insolent, male orc Ftr4:** CR 4; Medium-size humanoid (orc); HD 4d10+8; hp 35; Init +0; Spd 20 ft.; AC 17 (touch 10, flat-footed 17); Atks +9 (1d8+6/19-20, +1 heavy mace); SQ Darkvision 60 ft., light sensitivity; SR Nil; AL CE; SV Fort +6, Ref +1, Will +1; Str 16, Dex 10, Con 14, Int 9, Wis 10, Cha 12.

Skills and Feats: Spot +5, Listen +6, Hide +5, Intimidate +4; Dodge, Power Attack, Cleave, Weapon Focus (heavy mace), Weapon Specialization (heavy mace).

Possessions: +1 heavy mace, chainmail armor, large steel shield.

➤ **Grunic Darkeye, male orc Clr4:** CR 4; Medium-size humanoid (orc); HD 4d8+4; hp 28; Init +4; Spd 30 ft.; AC 11 (touch 9, flat-footed 11); Atks +5 melee (1d8+1/x3, longspear) SA Spells, rebuke undead; SQ spells, spontaneous cast of inflict spells, darkvision 60 ft., light sensitivity; SR Nil; AL CE; SV Fort +6, Ref 0, Will +7; Str 12, Dex 8, Con 12, Int 14, Wis 16, Cha 8.

Skills and Feats: Bluff +4, Concentration +8, Heal +6, Knowledge (religion) +3, Sense Motive +4; Alertness, Combat Casting, Weapon Focus (longspear).

Spells Prepared (4/4+1/2+1; base DC = 13 + spell level) 0—*cure light wounds* (x2), *detect magic, light*; 1st—*cause fear, cure light wounds* (x2), *protection from good**, *magic weapon*; 2—*bull's strength, endurance, spiritual weapon* (longspear)*.

* Domain Spells; Deity: Gruumsh; Domains: War (gain Martial Weapon Proficiency [longspear] and Weapon focus [longspear]) and Evil (cast evil spells at +1 caster level)

Possessions: Leather armor, longspear, wooden holy symbol of Gruumsh.

APL 6: ORC COMPLEX

➤ **Orc Barbarians, mix male and female orcs, Bbn2:** see above (APL 4)

➤ **Kiol the Insolent, male orc Ftr6:** CR 6; Medium-size humanoid (orc); HD 6d10+12; hp 48; Init +0; Spd 20 ft.; AC 17 (touch 10, flat-footed 17); Atks +9 (1d8+6/19-20, +1 heavy mace); SQ Darkvision 60 ft., light sensitivity; AL CE; SV Fort +6, Ref +1, Will +1; Str 16, Dex 10, Con 14, Int 9, Wis 10, Cha 12.

Skills and Feats: Spot +5, Listen +6, Hide +5, Intimidate +7; Dodge, Power Attack, Cleave, Great Cleave, Alertness, Weapon Focus (heavy mace), Weapon Specialization (heavy mace).

Possessions: +1 heavy mace, chainmail armor, large steel shield.

➤ **Grunic Darkeye, male orc Clr5:** CR 5; Medium-size humanoid (orc); HD 4d8+4; hp 38; Init +4; Spd 30 ft.; AC 11 (touch 9, flat-footed 11); Atks +5 (1d8+1/x3, longspear); SA Spells, rebuke undead; SQ spells, darkvision 60 ft., light sensitivity; AL CE; SV Fort +6, Ref 0, Will +7; Str 12, Dex 8, Con 12, Int 14, Wis 16, Cha 8.

Skills and Feats: Bluff +4, Concentration +8, Heal +6, Knowledge (religion) +3, Sense Motive +4. *Feats:* Combat Casting, Alertness, Weapon Focus (longspear).

Spells Prepared (4/4+1/3+1/2+1; base DC = 13 + spell level): 0—*cure light wounds* (x 2), *detect magic*, *light*; 1st—*cause fear*, *cure light wounds* (x2) *protection from good**; *magic weapon*; 2nd—*bull's strength*, *hold person*, *endurance*, *spiritual weapon* (longspear)*; 3rd—*prayer*, *wind wall*, *magic circle against good**.

* *Domain Spells;* Deity: Gruumsh; *Domains:* War (gain Martial Weapon Proficiency [longspear] and Weapon focus [longspear]) and Evil (cast evil spells at +1 caster level)

Possessions: Leather armor, longspear, wooden holy symbol of Gruumsh.

MAP #1: ORC COMPLEX

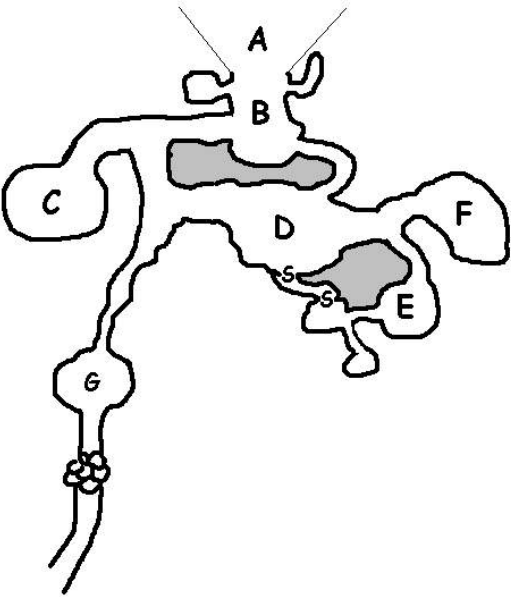

To the Dreadwood Forest

ENLISTING THE ICONIC

☞ **Tordek, male dwarf Ftr1:** CR 1; Medium-size humanoid (dwarf); HD 1d10+3; hp 13; Init +1; Spd 15 ft.; AC 17 (touch 11, flat-footed 16); Atks +4 melee (1d10+2/x3, dwarven waraxe), or +2 ranged (1d6/x3, shortbow); SQ Dwarven traits; AL LN; SV Fort +5, Ref +1, Will +1; Str 15, Dex 13, Con 16, Int 10, Wis 12, Cha 6.

Skills and Feats: Climb +0, Jump +0; Exotic Weapon Proficiency (dwarven waraxe), Weapon Focus (dwarven waraxe).

Possessions: Traveler's outfit, scale mail, large wooden shield, dwarven waraxe, shortbow, quiver with 20 arrows, backpack with waterskin, 1 day trail rations, bedroll, sack and flint and steel.

☞ **Mialee, female elf Wizr:** CR 1; Medium-size humanoid (elf); HD 1d4+3; hp 7; Init +3; Spd 30 ft.; AC 13 (touch 13, flat-footed 10); Atks +0 melee (1d6, quarterstaff), or -6 melee (1d6, quarterstaff) and -10 melee (1d6, quarterstaff), or +3 ranged (1d6/x3, shortbow); SQ Elven traits; AL N; SV Fort +0, Ref +3, Will +3; Str 10, Dex 16, Con 10, Int 15, Wis 13, Cha 8.

Skills and Feats: Concentration +4, Knowledge (arcane) +6, Listen +3, Search +6, Spellcraft +6, Spot +3; Scribe Scroll (virtual), Toughness.

Spells Prepared (3/2; base DC = 12 + spell level): 0—*daze, ray of frost, read magic*; 1st—*mage armor, sleep*.

Spellbook: 0—all of them; 1st—*charm person, mage armor, magic missile, sleep, summon monster I*.

Possessions: Traveler's outfit, quarterstaff, shortbow, quiver of 20 arrows, backpack with waterskin, 1 day trail rations, bedroll, sack, flint and steel, 10 candles, map case, 3 pages parchment, ink and pen, spell pouch, spellbook.

☞ **Lidda, female halfling Rogr:** CR 1; Small humanoid (halfling); HD 1d6+1; hp 7; Init +7; Spd 20 ft.; AC 16 (touch 14, flat-footed 13); Atks +1 melee (1d6/19-20, short sword) or +4 ranged (1d8/19-20, light crossbow), or +1 melee (1d4/19-20, dagger) or +5 ranged (1d4/19-20, dagger); SA Sneak attack +1d6; SQ Halfling traits; AL CG; SV Fort +2, Ref +6, Will +1; Str 10, Dex 17, Con 13, Int 14, Wis 10, Cha 8.

Skills and Feats: Climb +6, Disable Device +6, Gather Information +1, Hide +11, Jump +6, Listen +6, Move Silently +9, Open Locks +7, Search +6, Spot +4, Tumble +7, Use Magic Device +1; Improved Initiative.

Possessions: Explorer's outfit, leather armor, shortsword, light crossbow, 10 crossbow bolts, dagger, Backpack with waterskin, 1 day trail rations, bedroll, sack, flint and steel, thieves' tools hooded lantern, 3 pints of lantern oil.

☞ **Jozan, male human Clr1:** CR 1; Medium-size humanoid (human); HD 1d8+2; hp 10; Init -1; Spd 20 ft.; AC 15 (touch 9, flat-footed 15); Atk +1 melee (1d8+1, heavy mace), or -1 ranged (1d8/19-20, light crossbow); SA Turn Undead 4/day 2d6+2; AL NG; SV Fort +4, Ref -1; Will +4; Str 12, Dex 8, Con 14, Int 10, Wis 15, Cha 13.

Skills and Feats: Concentration +6, Heal +6, Listen +4, Knowledge (religion) +0, Spellcraft +4, Spot +4; Alertness, Scribe Scroll.

Spells Prepared (3/2+1; base DC 12 + spell level); 0—*detect poison, guidance, read magic*; 1st—*bles, protection from evil**, *shield of faith*.

* Domain spell; *Deity:* Pelor; *Domains:* Good (good spells cast at +1 caster level) and Healing (healing spells cast at +1 caster level).

Possessions: Cleric's vestments, scale mail, large wooden shield, heavy mace, light crossbow, 10 crossbow bolts, backpack with waterskin, 1 day of trail rations, bedroll, sack, flint and steel, wooden holy symbol (sun disk of Pelor), 3 torches.