

DUNGEONS & DRAGONS

# GAZETTEER

OFFICIAL GAME ACCESSORY

## The Northern Reaches

by Ken Rolston

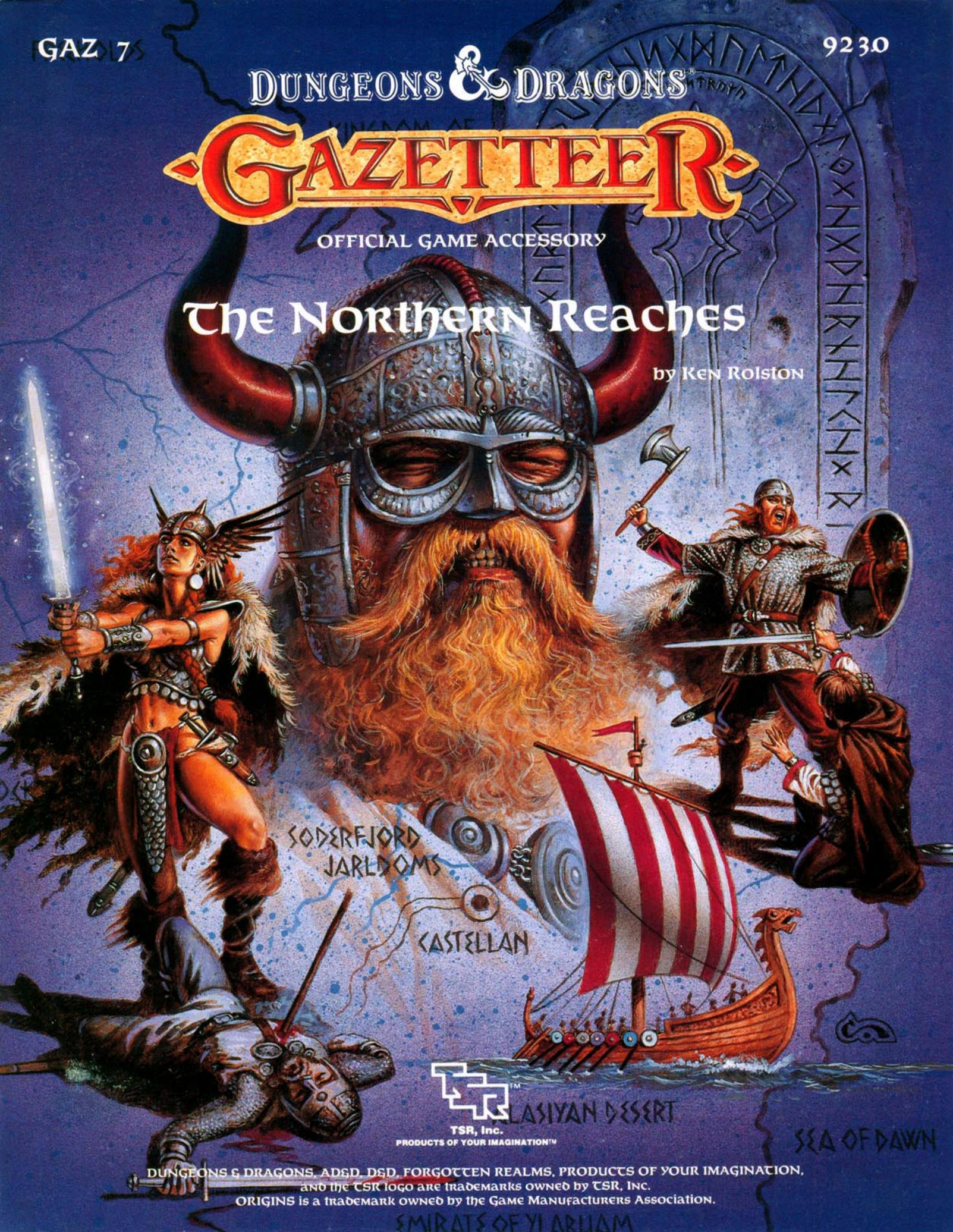

SODERFJORD  
JARLDOMS

CASTELLAN



TSR, Inc.  
PRODUCTS OF YOUR IMAGINATION™

ASIYAN DESERT

SEA OF DAWN

DUNGEONS & DRAGONS, AD&D, D&D, FORGOTTEN REALMS, PRODUCTS OF YOUR IMAGINATION,  
and the TSR logo are trademarks owned by TSR, Inc.  
ORIGINS is a trademark owned by the Game Manufacturers Association.

EMIRATE OF YI ABHAM

# Falun Cavern DM Map

Scale: 1 inch = 300 feet



**Artifact Recovery**  
 Location marked E, D, or M may contain gnomish artifacts. See Artifact Tables on page 44.

E = Easy  
 D = Difficult  
 M = Miraculous

Gnome Cult Sanctuary ↑

- upper level
- middle level
- lower level
- free-standing gnome structures

## English-to-Gnomish Alphabetic Replacement Code

a	п	h	н	o	з	v	u
b	г	i	!	p	н	w	□
c	в	j	л	q	г	x	р
d	≡	k	>	r	г	y	≡
e	u	l		s	:	z	L
f	†	m	L	t	l		
g	€	n	≡	u	ll		

# GAZETTEER

OFFICIAL GAME ACCESSORY

## The Northern Reaches

by Ken Rolston and Elizabeth Danforth

### Table of Contents

#### DM BOOK

Introduction .....	2
History of the Northern Reaches .....	4
Geography of the Northern Reaches .....	7
Nations of the Northern Reaches .....	9
Ostland .....	9
Vestland .....	14
The Soderfjord Jarldoms .....	18
Non-Human Races .....	23
Court of Cnute .....	32
Adventures .....	37
Falun Caverns .....	37
Otkel's Stead .....	47
The Jarl's Hall .....	57
Campaign Notes .....	60
Adapting Gazetteers to AD&D® Campaigns .....	64

#### PLAYERS BOOK

What Everyone Knows .....	1
Northlands Society .....	4
Creating Northman Player Characters .....	9
Clerics in the Northern Reaches .....	24
Power Runes .....	29
Falun Caverns Player Map .....	32

#### Credits:

Design: Ken Rolston, Elizabeth Danforth  
Editing: Elizabeth Danforth  
Product Manager: Bruce Heard  
Coordinators: Karen S. Boomgarden, Bruce Heard  
Cover Artist: Clyde Caldwell  
Interior Artist: Stephen Fabian  
Graphic Design: Stephanie Tabat  
Cartography: Dave Sutherland, Dennis Kauth  
Typography: Kim Janke and Betty Elmore  
Playtesters: Mike Doolittle, Dick Garner, Anna Harmaty,  
    George Johnson, Paul Rini, Dave Stephens, Martin  
    Wixted, Mark O'Green

AD&D, DUNGEONS & DRAGONS, D&D, FORGOTTEN REALMS, WORLD OF GREYHAWK, and BATTLESYSTEM are registered trademarks owned by TSR, Inc.

PRODUCTS OF YOUR IMAGINATION and the TSR logo are trademarks owned by TSR, Inc.

Distributed to the book trade in the United States by Random House, Inc., and in Canada by Random House of Canada, Ltd. Distributed to the toy and hobby trade by regional distributors. Distributed in the United Kingdom by TSR UK Ltd.

This module is protected under the copyright laws of the United States of America. Any reproduction or other unauthorized use of the written material or artwork herein is prohibited without the express written permission of TSR, Inc.

©1988 TSR, Inc. All Rights Reserved. Printed in U.S.A.

TSR Inc.  
POB 756  
Lake Geneva,  
WI 53147 USA



TSR UK Ltd.  
The Mill, Rathmore Road  
Cambridge CB14AD  
United Kingdom

ISBN 0-88038-573-1

9230

# Introduction

*"The Northman is without peer in courage and might of arms. None can question our glory and honor, and none shall stand against us in battle."*

Onund Tolundmire, Priest of Odin

*"Look, furriners say we're just barbarian pirates... axe-wielding homicidal maniacs who like to get together with friends, guzzle gallons of mead, and yowl moronic battle chants. I say... beats cleaning fish!"*

Dwalinn the Dwarf

## The Gazetteer

This sourcebook describes the Northern Reaches of the D&D® Game Known World for use in fantasy roleplaying campaigns. This package is designed primarily for Basic and Expert play. In this package are the following goodies:

- a 64-page DM Book, a DM's eyes-only description of the history, lands, peoples, legends, and nasty monsters of the Northern Reaches, with campaign adventure settings and scenarios.
- a 32-page Player Book, offering a player's-eye view of the Northern Reaches campaign, and containing new rules, a new system to create Northland characters, and a new rune magic system.
- a 22" × 34" full-color foldout map, printed on one side with a map of the Northern Reaches and the nations' capitals, and on the reverse with the layout of a Northman's hall and stead.
- 4 full-color inner covers, designed to be cut up and assembled as 3-D buildings for the jarl's hall layout.

## Is This The Vikings Or What? —

Sure, this is the Vikings. We've adapted them to the fantasy-adventuring of the D&D® game, borrowing cheerfully from the rich historical and mythological lore of the Vikings.

But this is not a historical Viking setting—that wouldn't be appropriate for most adventures. For one thing, an abundance of magic is commonplace in the D&D game, while in Viking history, mortals didn't see a lot of magic. For

another thing, this is a fantasy roleplaying game, not a historical roleplaying game.

So we give you plenty of Viking flavor, but don't confuse this flavor with the historical or legendary Vikings. For those who enjoy more historical detail, we've given you a list of swell references that we like, below. Use these to enhance the sense of reality in your games to the level that suits you.

## How to Use the Gazetteer

**PC Book:** Read this first for a quick overview of the campaign from a player's perspective. Players can read the PC Book without restriction.

The first section, "What Everyone Should Know About the Northern Reaches," introduces you to the essentials of Northland geography and culture. The second section, "Creating Northman Player Characters," provides procedures, tables, and notes on creating Viking-type player characters. The third section, "Clerics in the Northern Reaches," describes the special role of clerics in the Northlands, and provides rules for a new clerical magic system—"rune magic."

**DM Book:** This is a DM reference on the Northern Reaches.

The first section, "History of the Northern Reaches," outlines the history and geography of the three principal D&D® game world Northland nations: Vestland, Ostland, and the Soderfjord Jarldoms.

The second section, "Non-Humans in the Northlands," gives details on dwarves, giants, gnolls, and trolls. It also introduces the new humanoid race of the Modrigswerg—the moulder dwarves.

The third section details the Northland adventures for this setting. It covers the nations' capitals and also the adventure scenarios taking place elsewhere.

The final section, "Campaign Notes," describes how to develop your own Northern Reaches campaign. Several important settings for Northman adventures are elaborated.

Technically, the DM Book should be read by DMs only. Practically, if a DM

plans to design his own adventures in this setting, or develops only a few of the scenario ideas suggested here, players can probably read the DM Book without spoiling the campaign. Players—check with your DM, who should be able to excerpt what you can safely read. If he or she plans to run any scenarios from this book, do yourself a favor and don't spoil the suspense by reading other sections.

**Materials:** The inner covers are printed with the roofs and walls of a variety of buildings such as would be found in a Northlands setting. These cardboard buildings are meant to be chopped up and glued together so you have a collection of 3-D Viking-style buildings to use during a game or just to be amused by. Set them up on the fold-out map of the Jarl's Hall and Stead for a game. Further descriptions accompany the scenarios elsewhere in this book.

## Your Guides on this Tour

Four Northern Reaches natives are your narrators throughout this Gazetteer, both in the DM Book and in the Player Book. Knowledgeable, widely-traveled, and well-connected, these four characters speak with authority and charm to DMs about those elements of Northern Reaches life ideal for gaming. They are also NPC voices to speak to players, introducing native and foreign travelers to topics and places of interest to adventurers. Sometimes their views are ill-considered opinions and sometimes they can provide an insight to the Northern life that no foreigner could imagine.

Each character represents a different element of Northern Reaches culture.

- Helfdan Half troll, the classic hero—warrior, raider, trader, sea captain, and roughneck. Helfdan is our guide to the down-to-earth world of farm and stead, longboat and shieldwall, clan loyalty and love of war.
- Onund Tolundmire, itinerant priest of Odin—skald, entertainer and moralist, runereader and student of the tales of men and gods, of histories of this world and the next. Onund is our guide to the northern character as revealed in the histories of

men, monsters, and gods of the Northern Reaches, and to the role of the D&D® game cleric in this setting.

- Saru the Serpent, the “white” sorcerer—scholar and world-traveler, student of ancient races and cultures, trader and collector of rare artifacts. Saru is our guide to the magics and mysteries of the Northern Reaches, to the cultures and treasures of the Elder Races, and to the role of the magic user in the Northlands.

- Dwalinn the Dwarf—adventurer, philosopher, and tavern lout, skilled fighter, craftsman, liar, and cynic. Dwalinn is our guide to the shady side of the larger settlements, and to the dangerous borderlands and wildernesses of the Northlands’ hill and mountain regions.

There are other voices you’ll hear. Olaf the Taverner, for example, speaks for the thousands of practical residents of this region who want nothing to do with adventuring or adventurers. He regards most adventurers’ tales with skepticism, discounting ninety percent of it as snowdreams and troll dung.

On the other hand, most common folk believe uncritically in gods and heroes. The older and more often-repeated a legend, the more likely they are to regard it as truth, no matter how incredible.

As you get to know and love these NPCs, you’ll see how they can play an important part in your Northern Reaches campaign. Use them as NPC informants and contacts in your scenarios. Players love familiar characters, who also give the campaign coherency by acting as transitional elements between scenarios.

### Suggested Readings

Wise up. Where do you think we game designers get our neat ideas? From history and books about ancient cultures we get—free!—from the public library! We’ve included things we think will provide you with lots of exciting adventures, but no scenario book, including this one, even begins to cover everything you could adapt into a super game. If this subject interests you, and you’d like to play other games in a Viking-type setting, you won’t be wasting your time doing a little extra reading.

Ideas for good games practically leap off the pages of good library books!

We include the Dewey Decimal numbers for the books used for this Gazetteer. Hot tip: Go browse on the shelves where these numbers are found. The 948 section is particularly rich in big, lavishly illustrated picture books. Don’t steer clear of the juvenile books (the ones marked with a “J”) just because they’re in the children’s section. They’re well-illustrated (usually in color), quick reading, and lurid—lots of dead guys, bones and tombs, weapons, monsters, magic, and other neat stuff. Sound familiar? Just what we gamers and game designers are interested in, too!

### Books

*The Vikings*, Michael Gibson, Wayland Documentary Series. (J948.02) Quick read, good introduction to the Vikings.

*The Vikings*, Modern Knowledge Library, Warwick Press, Robin Place. (J948.02) Same as above, but with more pictures and less text.

*Growing Up with the Vikings*, Amanda Purves. (J948.02) A rather vague but fast look of everyday Viking life.

*The Viking Warrior*, Martin Windrow. (J948.02) Great color illustrations.

*The World of the Vikings*, Ole Klindt-Jensen and Svenolov Ehren. (948.031) Brilliant illustrations and neat narrative tidbits. Gives a real sense of place. My favorite.

*The Northmen*, Thomas Froncek. A Time-Life book. (913.031) As usual, lots of great pictures and drawings, including an account of modern-day reconstruction of an ancient homestead, a lot of neat treasures and common items, and tastefully ghastly treatments of the mummies of human sacrifices they found in Danish bogs.

*The Vikings and Their Origins*, David Wilson. (914.8031) Readable, with some useful floor plans of buildings, aerial photos of fort sites, and so on.

*The Northern World*, edited by David Wilson. (948) Covers the whole ancient history of Northern Europe, with nice bits on Celts and Slavs. Good pictures.

*The Viking World*, James Graham-

Campbell. (948.02) Good photos of the wild land. Detailed treatment of longships. Good diagrams and photos of treasures and art. Organized in readable chunks.

*Gods and Heroes from Viking Mythology*, Brian Branston. (J293.13) Super color illustrations, dramatic text. Tells about the mythological gods and their world, and gives a great sense of heroic Viking character through these mythic figures.

*Hrolf Kraki’s Saga*, and *The Broken Sword*, Poul Anderson. Two works of fiction that describe the flavor of this Northern world better than most. Look for these under “A” for Anderson, usually in the science fiction section.

### Other D&D® Game Products

These are official D&D game fantasy adventures in Northern Reaches settings.

*Curse of Xanathon* (X3), Doug Niles. A 32-page D&D® Expert adventure, set in the mountains of Vestland.

*Crown of Ancient Glory* (X13), Steven Bourne. A 64-page D&D Expert/Companion adventure dealing with the ruling dynasty of Vestland.

There are other excellent and well-researched sources. Seek them out.

“My name is Yon Yohnson,  
I come from Wisca Fjord,  
I work in a viking horde there.  
When I raid the seas,  
The people I seize,  
They ask me my name and I say..”  
(repeat endlessly)  
Northmen’s traditional drinking chant

# History of the Northern Reaches

Although modern history of the Northlands belongs to the human and humanoid races, the giantish and goblinoid cultures have been established in the hill and mountain regions for twenty-seven centuries. Only in the last three centuries has the Vestland region achieved any security from troll and giant raiders. In Soderfjord, kobold and hill gnoll clans still prey on frontier homesteaders and threaten the all-important trade routes.

**Retreating Ice Sheets:** The disastrous obliteration of the Blackmoor culture caused an axial tilt that shifted global climate patterns, causing the continental glaciers to recede from the regions now occupied by the nations of the Known World. At this time, the islands of Ostland and the lowlands of Vestland and Soderfjord were submerged.

**Humanoid Migrations:** After 1710 BC, three waves of migrations brought the ancestors of the current humanoid populations out of the frozen north. They migrated slowly into the recently-revealed hills and mountains of modern Rockhome and the Northlands.

The first wave brought the hill gnolls—primitive and unprepossessing country cousins of the giant races. Driven out of the north by the more aggressive and better-organized trolls and giants, the hill gnolls settled throughout the highlands of modern Rockhome and the Northlands. Lacking weaker or stupider opponents, the hill gnoll clans fought one another for the scarce resources of this new and barren land.

The second wave included the various sub-races of trolls: the common root troll (the standard troll described in the D&D® Expert rules); the uncommon earth troll (a larger, more durable, less intelligent troll); the rock troll (a slow, powerful, and unusually peaceable species); and the giant troll (generally thought to be extinct in this region). The troll clans settled mostly in the western hills of modern Vestland.

Legends say that the troll races are among the oldest living things on the

planet. Because of their close connection to the earth, the sedentary earth, rock, and giant trolls have been known to “go to sleep”—to become immobile and indistinguishable from the earth and rock where they rest.

The giants were the third wave, primarily hill giant and stone giant clans, with sizable minorities of the other well-known giant sub-races like the fire and frost giants. These clans settled predominantly in the mountains of eastern Rockhome. Scattered clans inhabit the western highland borders of Vestland and the Jarldoms, and the Hardanger Range bordering Soderfjord and the Emirates of Ylaruam.

In addition to these better-known giant sub-races, the Rockhome and Northland mountains are also the refuge of many of the more remarkable giants, called “great giants.” Reputedly, these beings may grow over twenty feet tall, and they are possessed of powerful magical abilities, including shapeshifting, spellcasting, runemagics, and the use of powerful artifacts. They are said to be capable of challenging the Immortals themselves to personal combat. Fortunately, these aristocrats of giantdom show little interest in the affairs of men, and are only encountered by the most persistent and intrepid adventurers.

**Early Human Settlements:** Around 2000 BC, early Bronze Age peoples came to the Northland islands and to the coastal lowlands from the region of modern Norwold. They brought with them primitive agricultural methods and cultural traditions, but they were also skilled seamen and fishermen. Most of the Northland lowlands and islands are good for agriculture, though the land is rugged and infertile along the northern coast, and covered with forests and marshes along the southern mainland and the off-shore islands.

Most communities were very small, ruled by a petty chieftain who was likely to be chosen for his strength of arm and his fighting abilities. Most villages “communicated” only through raiding and warfare. From the very beginning, the

Northman had to be as skilled with his weapons as with the tools of his trade. The survival of every community depended on the warrior skills of each individual member.

The Northlands fell under Nithian domination around 1000 BC. The Nithians themselves showed little interest in these lands with their cool, wet climate, and they avoided the highland wildernesses out of fear of the hill gnoll and troll clans. While a few trading posts were established along the fjords and rivers, many Northlanders’ only connection with the empire was when they or their kin were taken as slaves and transported to the Nithian Empire. When the empire collapsed in 500 BC, the few traces of Nithian culture in the Northlands faded within a decade.

Early Northland cultures practiced shamanistic and rune magics, but it was the Nithians who brought the formal spellcasting sciences to this region. That remains their only lasting contribution to the area. With the disappearance of the Nithians, spellcasting in the Northlands stagnated, a primitive and obscure art for another ten centuries.

**Dwarven Cultures:** Relatively little is known of the early history of the Modrigswerg dwarven culture of the Northlands. Known as “moulder dwarves” by their western cousins in Rockhome, legend says that these dwarves were driven out of the Rockhome region for breaking ancient clan traditions against trafficking with spellcasters and alchemists. Said to be a cursed people, their name is now associated with madness and evil.

Less social than Rockhome dwarves, the Modrigswerg prefer to live in small family units, or as isolated hermits. They are known for the quality of their stonework, jewelry, and weaponsmithing. Their superb physical craftsmanship combines with the secret arts of dwarven craft-magic to produce marvelous artifacts. However, the moulder dwarves are considered greedy and malevolent at worst, greedy and mischievous in general, and shy and antisocial at best.

As is typical in dwarven cultures, Northland dwarves are extremely conservative in traditions and customs, but uninterested in tales or histories. Further, the Modrigswerg are not inclined to be chatty about their past. Consequently, very little is known about these demihumans, and tracing the origin and fate of legendary artifacts is a formidable task.

Modrigswerg are said to be particularly long-lived, even for dwarves, although the madness associated with the clan leads many of them to their own destruction. Clans and families generally remain in the same dwellings for centuries. There are no acknowledged kings or clan leaders, and there is little communication between underground homesteads. Families and small clans may live within five miles and not speak to one another for hundreds of years.

The Northlands are also home to numerous Rockhome emigres, accounting for approximately two percent of the total population in the Northern Reaches. Most of these dwarven immigrants have arrived within the past four centuries. Rockhome emigrants are generally accepted as native Northlanders, although there still remains a considerable prejudice against dwarves in many rural and conservative communities.

**The Tragedy of the Northland Gnomes:** Little remains of the ancient Northland gnomish culture. One may mark its traces by the vast labyrinthine corridors of their underground cities, now occupied by kobolds. Moreover, curious artifacts are occasionally taken from the bodies of kobold raiders—artifacts of ancient and curious gnomish design.

The gnomes apparently came to the Northlands from the Altan Tepe mountain range around 2500 BC. They successfully co-existed with the other humanoid races because the underground passages of the tunnel complexes were too small for gnolls and trolls to enter. Relations with the Modrigswerg clans were distant, formal, and occasionally acrimonious by dwarven accounts, but some trade occurred, as evidenced by a multitude of

ancient gnomish artifacts in the moulder dwarves' treasure troves.

In 490 AC, several waves of kobolds were driven into the region from the west, fugitives from the armies of Rockhome. Never a numerous race, the gnomes were greatly outnumbered by the more prolific kobolds. Moreover, the gnomes lacked a substantial military tradition. Within just a few decades, the aggressive and warlike kobold clans had exterminated all but a few fleeing refugees. The subterranean farms, mines, and tunnel cities were occupied by the kobold conquerors.

For decades, the kobold races have kept to themselves in their underground fastnesses, apart from occasional warrior raids. The human nations of the Known World take little note of their affairs. However, the recent increase in kobold raiding in southern Soderfjord may be a sign that this situation is changing.

**The Rise of the Ostland Sea Pirates:** Early in the fifth century A.C., a handful of war leaders rose to prominence along the coasts of Noslo and Kalslo Islands. Uniting small communities into larger war clans by conquest, marriage, and diplomacy, these barbarian chieftains battled each other constantly, each seeking to extend his control over the region. These warrior chiefs developed the art of mobile seaborne warfare, and extended the practice of raiding to include more distant targets along the coasts of modern Ylaruam and Norwold. These leaders gradually became more powerful, more militarily organized, and more wealthy.

Finally, one king rose above the others. After a series of decisive battles, Cnute of Zealand was declared King of Ostland in 478 AC. His ascent was assisted by the shrewd diplomatic skills of his wife, Gudrid, and by the foreign sorcerers enlisted by Gudrid and her advisors.

Cnute and Gudrid were ruthless but effective monarchs, welding the quarrelsome Northern clans into a single nation of sea-roving warriors. The descendants of their dynasty still hold the thrones of modern Ostland and Vestland.

**The Sons of Cnute:** In the early sixth century, Cnute's three youngest sons—Eirik, Sven, and Hrafn—led a series of expeditions to colonize the region of mainland now known as Vestland. The sons of Cnute establishing settlements along the coast, and as far inland as Rhoona on the Vestfjord River. They also founded towns well into the hill country near Landersfjord.

With these communities as their bases, the sons of Cnute solidified their father's rule over the lowland regions. They also led raids into the hill country against the troll and giant populations. For this alone the sons of Cnute were welcomed, more often greeted by the local clans as protectors than as conquerors.

When Cnute died in 526, rule of Ostland passed to Cnute's eldest son, Brand, who remained a puppet of Queen Gudrid until her death in 552. Brand and his descendants continued to grow in power through raids and piracy, while the younger sons of Cnute remained on the mainland, earning a reputation for heroism and leadership against the multitudes of hostile humanoid raiders. They encouraged craftsmanship and trade in the growing mainland towns, and protected landowners from trolls and giants, and from the raids of the Ostlanders.

**The Kingdom of Vestland:** The royal house of Cnute, while technically the protector of the Vestland region, treated the mainland as a rich treasure house to be pillaged for the gain of the rulers alone. The monarchs took the wealth, giving little in return.

In 604 AC, Ottar the Just refused to pay the increasingly burdensome tribute demanded by his cousin, King Finnbogi of Ostland. Ottar spoke for all the jarls of Vestland, and every jarl on the mainland stood by him, also refusing to deliver their tribute. The outraged king of Ostland sent his jarls against the rebellious Vestlanders, and the young nation endured a decade of punitive raids wreaking great havoc up and down the coast of Vestland.

Direct opposition led to the Ostlanders' seige of Norrvik. The seige ulti-

## History of the Northern Reaches

mately failed. In 614, the ships of Ottar and his allied jarls trapped the beseiging forces in the Battle of Bridenfjord. King Finnbogi was captured and forced to sign a treaty acknowledging the sovereignty of the new Kingdom of Vestland. Ottar was promptly crowned the first King of Vestland.

**The Soderfjord Jarldoms:** A poor land of marshes and rugged coasts, plagued by gnoll, kobold, and Ostland raiders, and the frequent misrule of many petty jarls, Soderfjord is the weakest and most backward of the Northland nations. Soderfjord's jarls have always been quick to sell one another out to the highest bidder, and reluctant to risk their own resources to protect a neighbor. Consequently, the hills and mountains of Soderfjord are dangerous wildernesses, seldom traveled by men. Caravans on the Overland Trade Route must look to their own guard escorts for protection.

In 950 AC, the regions' jarls met at the Council of Soderfjord where, after much bickering and scheming, the Nordhartar Defense League was formed. This body is comprised of all the jarls of Soderfjord, who meet every six months to consider laws and affairs of state.

The League has signed mutual defense treaties with Ylaruam and Vestland, hoping to discourage Ostland's policy of ignoring its clans' raids on Soderfjord. However, neither Ylaruam nor Vestland wishes to risk a war with Ostland, so the raids continue while Ostland's official position is to politely disavow knowledge of such raids.

Ylaruam and Vestland have also agreed to aid Soderfjord in making the Overland Trade Route safe for caravan traffic. Vestland and Ylaruam contribute to mercenary expeditions organized by the Defense League—expeditions to patrol the trade route, to pursue raiders into the hills and mountains, and to locate and destroy gnoll and kobold strongholds.

**Historical Note:** For this and other D&D® game Gazetteers, the present time is 1000 AC. **Crown of Ancient Glory** (X13), a D&D® Expert adventure set in

Vestland, takes place a century and a half after the time period of this Gazetteer. Vestland has become progressively more modern and feudal, like the Grand Duchy of Karameikos. The worship of the Northman pantheon has waned among the noble and middle classes, and been supplanted by the growing influ-

ence of the Ruthinian faith, a lawful and civilized religion. The Trollheim hills have been pacified and colonized. With the removal of the troll nations as a buffer state, relations between Ethengar and Vestland have become strained, and border raids by both nations have become commonplace.

---

## Historical Timeline of the Northern Reaches

---

- 3000 BC:** The Great Rain of Fire. Blackmoor culture obliterated; planet tilts on its axis, causing ice sheets to recede from D&D® Game Known World.
- 2500 BC:** Gnomes and dwarves enter the region and settle in hills and mountains as continental ice sheets recede.
- 2000 BC:** First human settlements in coastal and island lowlands.
- 1700 BC:** Giants, trolls, and gnolls are driven south into the Northern Reaches in successive waves of migration.
- 1500 BC:** Modest Bronze Age human cultures in eastern lowlands. Sophisticated gnomish and dwarven cultures co-exist with primitive giantish clans in western uplands.
- 1000 BC:** Human cultures conquered and enslaved by Nithian Empire.
- 500 BC:** Nithian Empire collapses. Weak mainland human tribal cultures at mercy of giantish clans.
- 490 BC:** Kobold clans driven into uplands from the west. Kobolds overrun and exterminate gnomes, and occupy their subterranean kingdoms.
- 0 AC:** First Emperor of Thyatis crowned.
- 400 AC:** Ostland raiders range south to Thyatis and north to Norwold. Mainland tribes victimized by sea raiders and giantish clans.
- 478 AC:** Ostland united under King Cnute the Bold.
- 500 AC:** Sons of Cnute colonize mainland. Troll and giant raids discouraged by punitive expeditions.
- 614 AC:** Ottar the Just defeats King Finnbogi of Ostland in Battle of Bridenfjord, establishes Kingdom of Vestland. Ostland continues to raid southern mainland coasts. Vestland pursues trade with Alphatian and Thyatian colonies in D&D® Game Known World.
- 950 AC:** The Nordhartar Defense League is formed at the Council of Soderfjord, creating the Soderfjord Jarldoms. Treaties with Vestland and Ylaruam aid Soderfjord in securing Overland Trade Route through Castellan and challenge Ostland to desist coastal raiding. Ostland in turn allies with Thyatian Empire.
- 1000 AC:** Vestland is a modern nation and a strong, independent trading partner with the nations of the Known World. Ostland is a powerful, independent ally of Thyatis, aggressive and belligerent, barbaric in culture and religious practices. Soderfjord is a weak alliance of feuding minor jarls, victimized by giantish clans and Ostland pirates.
- 1150 AC:** The deaths of High King Maramet of Vestland and his sole heir throw the nation into political turmoil. The Sorona, the enchanted crown of Vestland, is sought by various factions hoping to claim the throne.
- 1200 AC:** Embassies of Republic of Darokin and Desert Nomads court Northern nations' alliance in the Great War. (See modules X4 and X5.)



# Geography of the Northern Reaches

The landscape of the Northern Reaches is a tilted plane sloping down from the high southwestern mountains to the low northeastern coast and offshore islands. The climate ranges from a cool, moist, maritime-temperate climate along the coast, to a cold subarctic climate in the higher elevations of the southern and western mountain ranges.

About one-fourth of the land is suitable for agriculture, most of it in the Ostland Islands and along the mainland coasts, rivers, and fjords. Another one-quarter of the land is only suitable for grazing, primarily in the mainland interior and foothills. Half of the land is raw wilderness entirely unsuitable for human habitation. The wilderness includes regions of rugged alpine, dense forest, and marshy terrain.

## The Mountains

The Makkres Range of Rockhome forms the western border of the Northland region. The spine of this range, rising to several peaks over 15,000 feet high, presents a formidable wilderness barrier to east-west travel, broken only by the Vestfjord and Nordesfjord valleys.

The Hardanger Range forms the rugged southern border of the Soderfjord Jarldoms. These sandstone and limestone mountains form a ridge wall up to 10,000 feet high, with individual peaks rising to 13,000 feet. This wall is broken in the west only at Jotunvalk Pass along the Overland Trade Route, where the caravan road passes for thirty miles through a series of 7,000-foot high passes and rugged alpine valleys.

**Climate:** The Makkres Range and the Hardanger Range have a cold alpine climate: a very cold fall, winter and spring, followed by a short, mild summer. Heavy snowfalls are expected from early fall through late spring; even in summer, terrible mountain storms may threaten travelers with a foot or more of snow.

**Terrain:** With their rugged peaks, vast glaciers, steep slopes, and rocky valleys, the Makkres and Hardanger Ranges are

not suitable for human habitation. The rugged terrain and harsh climate make travel extremely difficult and dangerous. Many parts of this region are underlain by limestone honeycombed with natural caverns—ideal terrain for dwarves, kobolds, giants, dragons, and other intelligent, non-human races.

The mountains are believed to hold great mineral resources. Extraction and transportation of mineral wealth in such rugged terrain, and through the territories of hostile non-human natives, is prohibitively expensive and dangerous.

**Population:** Human population is fewer than one person per square mile. A few folk tend isolated trade posts and way-stations along major caravan routes, and individual trappers and adventurers travel the wilderness. The extent of the non-human population is unknown; estimates suggest 5-10 kobolds or more per square mile in some regions, with scattered giant and dwarven residents.

## Hill Country

The high hills of Trollheim form the western half of Vestland. The naked granite domes and the wind-swept heathlands of the high moors rise above the dark, wooded valleys of this region.

The grass-swept high plateau and the wooded foothills of the Makkres Range run from Rhoona in the northwest to the

Castellan Valley in the southeast, sloping into the forest and lowland marshes of the coastal plateau.

The Gnollheim hills run north from the foothills of the Hardanger Range to the Soderfjord Great Marsh region and east to the spectacular 500-foot high cliffs of the Ostfold Scarp along the seacoast.

**Climate:** The Northland hill country has a cold, temperate, humid climate with cold winters, a cool to moderate spring and fall, and warm summers. Precipitation in the north is moderate; in the west and south, the precipitation is moderate to heavy, with heavy snowfall in the winter and violent thunderstorms in the summer. The Trollheim hills are swept year-round by high winds, creating treeless high moors and dense woods in sheltered hollows.

**Terrain:** In the Trollheim hills, the terrain rolls with steep slopes and rocky outcrops dropping into narrow, wooded valleys. Soft, wet turf and low bogs make travel in the lowlands difficult. Human travelers are forced to keep to the barren high ground where they are easily spotted from troll watchposts.

The foothills of the Makkres and Hardanger Mountains are rocky and inhospitable, broken by many steep-sided ravines, valleys, and cliffs. Some areas are marginally suitable for raising sheep. The non-human nomadic herder cultures like the



## Geography of the Northern Reaches

hill gnolls are better suited for the terrain.

Vestland and Soderfjord encourage settlement of these regions with land grants. Farming and grazing lands are limited, and hostile non-human residents vigorously defend their prior claims.

**Population:** Human population is fewer than one person per square mile, concentrated along river valleys and the lands bordering the plateau region. Non-human population is undetermined; estimates suggest fewer than five trolls per square mile in the Trollheim hills, five to ten gnolls per square mile in the Hardanger foothills, and scattered giant and dwarven residents.

### The Coastal Plateau

The eastern half of Vestland, the northern coast of Soderfjord, and virtually all of the Ostland islands are part of a broad coastal plateau. The land varies between 100 and 300 feet above sea level, sloping abruptly to the sea and down the deep river valleys.

Founded on a durable bedrock resistant to erosion, this plateau offers poor to indifferent soil for agriculture. Good farmland is scarce, generally found only in the river valleys and in narrow strips along the coast. The land is, however, generally suitable for grazing.

**Climate:** The plateau's climate is temperate and humid, with a cold winter, a mild spring and fall, and a hot summer. Precipitation is substantial year-round; most winter precipitation falls as snow.

**Terrain:** This rolling, rocky plateau is covered with scattered forests, woodlands, and grassy plains. Ninety percent of the Northland's population is found in the river and coastal valleys, where farming can be supplemented by fishing. Towns are few and small except for the major trade centers. Most people live in scattered farming and fishing communities.

**Population:** Human population ranges from 5-10 persons per square mile in forest regions, to over 20 people per square mile along the great river valleys and near the large trading towns.

### The Great Marsh

The Great Marsh is at the heart of the Soderfjord Jarldoms, a wild region with little to recommend it.

**Climate:** The Marsh has a temperate, humid climate, with cold winters, a moderate spring and fall, and warm summers. There is moderate year-round precipitation, falling in winter as snow.

**Terrain:** This region of small lakes, meandering streams, wooded swamps, and scattered islands of high ground is subject to severe flooding during the spring and summer. The land is useless for agriculture. Wildlife is abundant, and fur-trapping is a marginal occupation. Travel is easiest by ski in the winter when lakes and streams are frozen.

**Population:** Human population does not exceed five persons per square mile. Non-human population is negligible, with occasional reports of red or black dragons.

### The Rivers

The Northland's deep river valleys cut through every part of the country. Shallow-draft Northman longships range deep inland along these rivers, making waterways the primary channels of travel and communication in the Northlands.

Two rivers—the Vestfjord River and the Landersfjord River—cut through the Makkres Range to the west, reaching far into the Great Lakes region of Rockhome. These rivers are broad highways into the mainland, easily navigable as far as Rhoona on the Vestfjord, and to the town of Landersfjord on the river of the same name. Beyond these points, the rivers are swift-flowing, rocky, and treacherous. Longships and rafts with a bold crew and captain may pass through the Vestfjord Gap throughout the summer and early fall.

In the south, several great rivers drain the alpine glaciers of the Hardanger Range, beginning as violent cataracts in the mountain and hill country, then becoming wide meandering rivers as they flow through the marshy lowlands of

Soderfjord toward the sea.

### Native Flora and Fauna

**Plant Life:** The plateau country in its wild state is a mixture of conifer and broadleaf forest with patches of open grassland. Much of this area is currently under production as cropland and pasture. Crops include barley, rye, oats, and assorted root vegetables.

In the Trollheim hills, the high moors are covered with low, hardy heather, while ash and yew dominate the groves of the sheltered dales.

A portion of the plateau country and most of the hill country is covered by a mixed conifer-broadleaf forest. These virgin forests are dense wildernesses, only broken by thick stands of undergrowth, and low, boggy areas that impede travel.

The slopes of the Makkres and Hardanger Ranges are covered with conifer forests. Most places the forest floors are clear of undergrowth, but travel is sometimes impeded by dense thickets of hardy shrubs and wind-thrown jumbles of tree trunks. At higher elevations, only sparse alpine and sub-alpine vegetation can be found.

**Mammals:** Domestic species include horses, cattle, sheep, goats, dogs, and cats. Rats, wild dogs, and deer are common near settled areas; boars, elk, brown bears, wildcats, and occasional packs of wolves are found in the mixed forests. In the southern foothills, nomadic gnoll clans herd the mountain sheep and the great bison. Deer, elk, wolves, bear, and mountain lions are more numerous in the mountain regions.

**Birds:** In the mountain regions, hawks are popular pets; wild eagles are common in the mountain forests.

**Reptiles:** The only large reptiles of the Northlands are the cold drake—occasionally reported in the Hardanger Range—and the red and black dragons which are sometimes sighted in the Great Marsh.

**Marine Life:** The kraken and the greater sea serpent are an occasional threat to shipping in Northland waters.

# Nations of the Northern Reaches

The political boundaries of Ostland, Vestland, and Soderfjord as depicted on maps are polite fictions. Over half of the western and southern hills and mountains that are claimed by Vestland and Soderfjord are in fact uninhabited by humans. In many cases, the territories are firmly controlled by various non-human clans.

Neither are the districts of the Northern Reaches "nations" in the modern sense. Only Ostland has a strong central government, and that is maintained only through the monarch's ruthless application of military force, his actions supported by the powerful priest class. Vestland's king has great prestige and is a strong leader in military affairs, but Vestland's jarls retain considerable authority within their own domains. The only form of "centralized government" in Soderfjord is the Nordhartar Defense League, which meets only two weeks a year and spends most of that time arguing over who sits where at the conference table.

Finally, any fair account of the Northern Reaches must consider the importance of the regions' non-human cultures. While human cultures dominate trade, economics, communications, and warfare in the Northern Reaches, as is common throughout most of the D&D® Game Known World, the non-human cultures are too important to overlook. Individually and on their own ground, the older races have proved more than a match for the humans, blunting the humans' expansion of their frontier. Further, the prospect of a hostile non-human army organized under a single charismatic leader is a threat to all nations of the Known World.

## Ostland

**GOVERNMENT:** The Northlands cultural tradition has continued in this region unbroken for three millennia, since the earliest human settlers came here around 2000 BC. Early Bronze Age cultures evolved into the original Northlanders first on the Ostland islands. For this reason, Ostland is the most traditional of the Northern cultures, retaining many of the

best and worst features of the Northlands' barbarian heritage.

**Cultural Continuity:** In their earliest history, the Northman clans living on the Ostland islands were too primitive and disorganized to present a threat to a civilized nation, so the Nithians showed little interest in the islands. On the mainland it was a different story: the local cultures were depopulated, demoralized, and obliterated by Nithian conquest, disease, and slaving. Unlike much of the mainland, the Ostland islands offered decent soil for farming; thus, from 500 BC to 500 AC, Northland culture remained stable and healthy only on the offshore islands.

**The Rise of the Zealanders:** During those fifteen centuries, the Northmen were an undistinguished assortment of barbarian clans. Each clan fought with every other clan, generally for sport and loot, and occasionally in minor wars of conquest. No clan leader held sway over more than a fraction of the Northern tribes at any one time.

Then, late in the fifth century AC, a powerful Zealand clan consolidated power through a combination of strength in war and shrewdness in diplomacy. This clan established the first widely acknowledged king of Ostland, Cnute Bearchest. Cnute's power proved strong enough that the royal house eventually established itself as a clan within a clan—

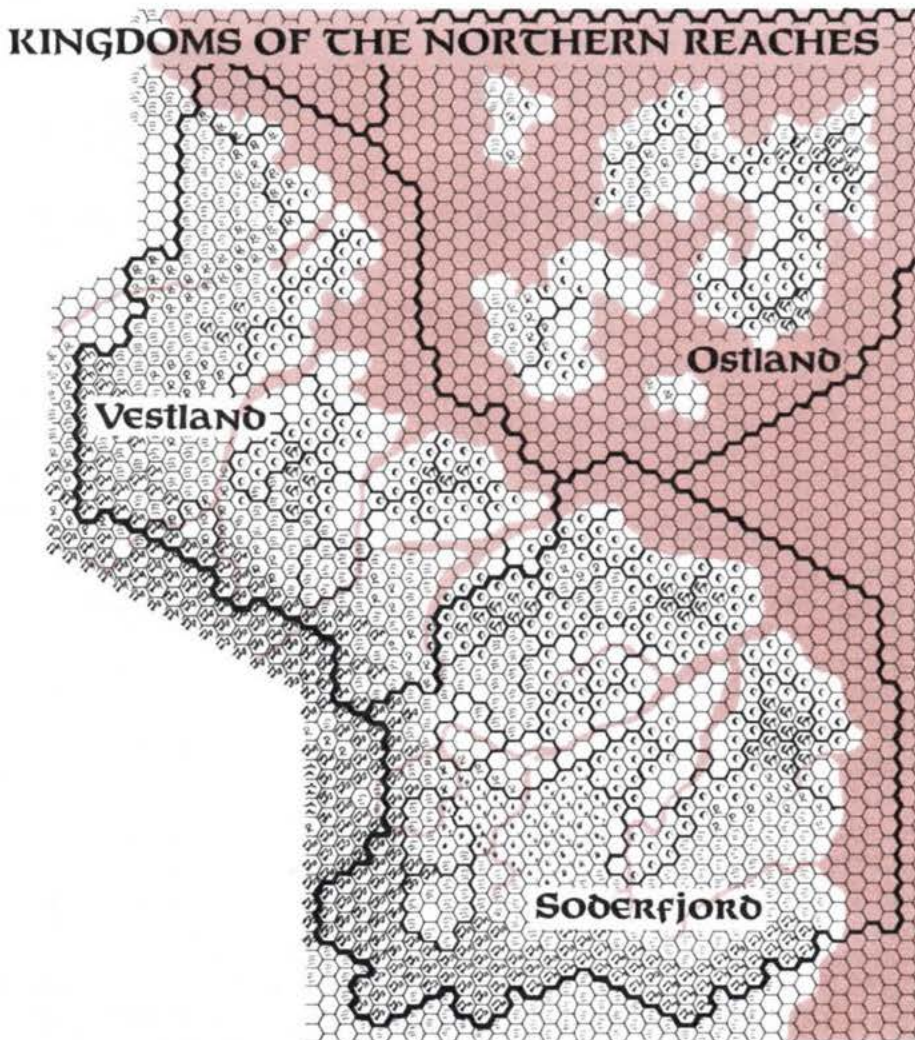

## Nations of the Northern Reaches

the royal Cnute clan, within the noble and honored Zeaburg clan.

Cnute was a powerful warrior and a competent general, with a sure grasp of both land and sea tactics that exploited his people's skill with the longboat. Gudrid, the new queen of Ostland, was every bit as shrewd a diplomat and counselor as her husband was a warrior. They established the pattern that was to sustain their dynasty and nation.

**The Secret of the Cnute Clan Success:** The Cnutes have always relied on strong leadership as the core of their power. In hereditary monarchies, this is sometimes an uncertain prospect. The royal offsprings may be idiots or weaklings, or they might marry for romance or lust rather than for political advantage.

The Cnutes exploit the practice of fosterage, rather than relying solely on succession by birth. The finest young nobles of all the Ostland clans are invited to live in Zeaburg in the Royal Compound, where they form the King's Royal Court and Personal Guard (known collectively as the "Royal Household"). From this hand-picked assemblage, the ruler of Ostland finally selects and adopts his successor, although it is often a natural-born child of the monarch who is chosen. In any case, the heir is considered just as much of "royal blood" as if he or she were born of the king and queen.

The Court of Cnute also attracts many adventurers and young nobles with poor prospects of inheritance. Those who distinguish themselves in some way—in contests, in heroic feats, or through skald-enhanced reputations—are occasionally offered the hospitality of the Royal Clan. Once in the Royal Court and Personal Guard, the chances of personal and political advancement are good.

**The King and Queen:** Ten years ago, the then-current rulers of Ostland, King Hord Dark-Eye and Queen Rhora Anlafsdottir, were typical Cnute Clan monarchs. Hord was in his prime, a fearsome fighter, a veteran of many adventures and pirate raids, and an experienced general. He led several of his warbands as allied troops

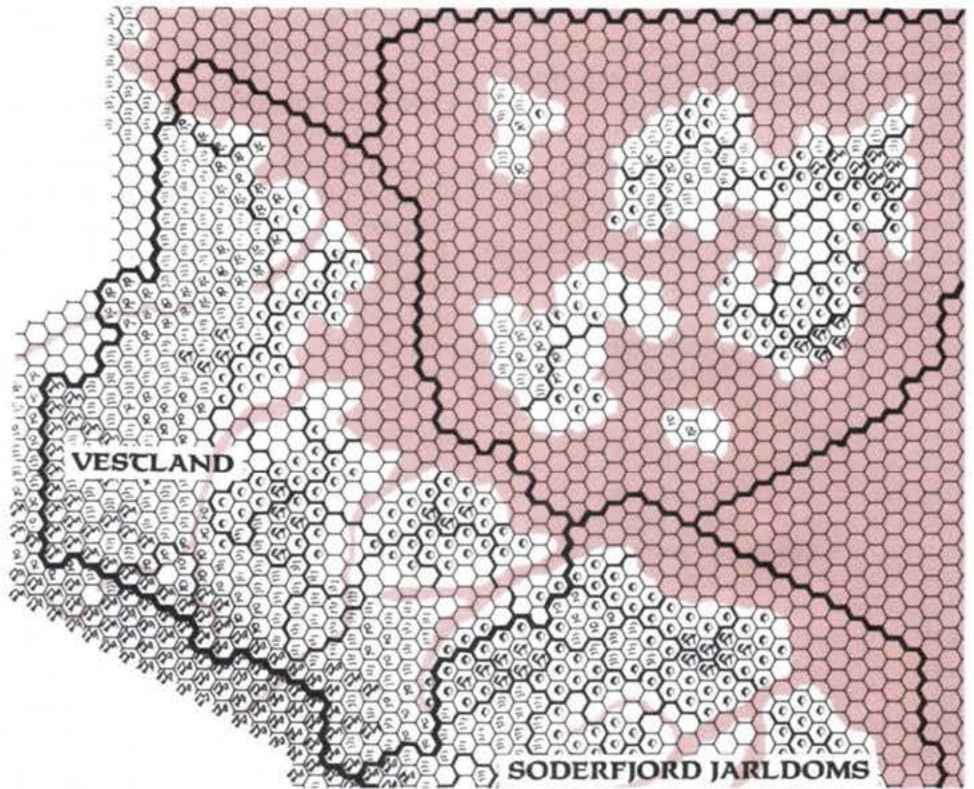

(“mercenaries” would be more accurate) for Thyatis in Norwold campaigns.

But Hord hoped to raise his own child to his throne—an acceptable route when a child proved worthy, but not something a Cnute monarch could plan for. However, Rhora died in childbirth, with the child lost as well, and Hord's interest in rule waned.

In his depression, King Hord's political power began to slip into the hands of the powerful priests of Odin. Recently a new player has entered the political game: the king's new young wife, Queen Yrsa, whose vision promises unprecedented change to Ostland as she consolidates her power.

**The Royal Household:** The king's Personal Guard is a 900-man elite brigade, comprised of the finest nobles and warriors of Ostland. The Brothers of the King, the king's twenty-man honor guard, are the hand-picked cream of this crop. These warriors are often in the main hall at royal feasts, and they enjoy the king's total protection. This makes them, practically speaking, above the law.

No more arrogant or scornful group of

warriors are you likely to find anywhere in the Northlands. Thirty percent of this force is female, proud warrior-women who have proven their mettle. The king fancies having Valkyrie shield-maidens, in imitation of Odin All-Father.

The Queen's Court boasts the finest skalds, fairest maidens, shrewdest scholars, and craftiest schemers in the Northlands. There is endless shuffling for position as alert nobles and courtiers seek to understand and get close to the popular young queen.

**The Ravenguard:** These warriors and priests dedicated to Thor are the constant companions of the king. These men, known commonly as berserkers, submit themselves to spell-induced madness in combat.

Berserkers are generally arrogant bullies, moody and unpredictable, and liable to pick fights with any who will not humble themselves before the Blessed Warrior of Thor. There has been no love lost between the Brothers of the King and the Ravenguard. Drunken assaults, homicide, and long-term blood feuds are common.

## Nations of the Northern Reaches

### Kingdom of Ostland: Dominions and Major Settlements

Hex #	Domain Area	Pop. sq. mi.	Major Settlement/Pop.
1.	Vestpont	360	6000
2.	Sumarland	375	3000
3.	Ringmark	330	3500
4.	Hammersholm	275	4000
5.	Noslosford	470	7000
6.	Vithesford	250	2200
7.	Thorholm	250	1500
8.	Aland	195	2000
9.	Varmgard	500	12000
10.	Haltimark	220	7000
11.	Havardholm	220	2000
12.	Suddmore	275	2500
13.	Steingard	390	2400
14.	Romaland	220	3500
15.	Fallersholm	385	9000
16.	Zeamark	415	20000
17.	Hedmark	275	2100
18.	Gotland	525	6000
19.	Osterlo	195	1400
20.	Sognesholm	360	2000
21.	Ostmanland	610	8000
22.	Kalsloviki	695	8000
23.	Oland	635	9000
24.	Kunslo	495	2000
	<i>Total</i>	8920	126100

**The Priesthood of Odin and Thor:** The worship of these Immortals in Ostland is established law, and the priests wield much power. The king is closely counseled by the high priest of Odin, Asgrim the Bowed, who has his own staff of high-level clerics. Queen Yrsa is also assigned a priestly advisor, but she adeptly circumvents his efforts to control her. Each clan's chief jarl has a priest to advise him "on spiritual matters."

The churches of Odin and Thor in Ostland maintain many of the dark, brutal pagan practices of the Northman traditions—practices long ago abandoned elsewhere. Ritual torture and even human sacrifice are still practiced in Ostland. The disapproval of foreigners has forced the government and the priesthood to disavow knowledge of these practices as a matter of policy.

### Ostland's Policies

The king places no restrictions on his jarls regarding raids carried out in foreign lands. He even turns a blind eye to occasional raiding for sport among the Ostland domains if the victim is out of favor at court.

Exploration and colonization of lands to the east and north is encouraged. The rulers provide funding for expeditions to the Isle of Dawn, to the southern archipelagos, and to Norwold.

Ostland's indifference to the piracy and raiding of its clans has strained relations with virtually every nation in the North. Vestland, Soderfjord, Ylaruam, and Norwold are all displeased with the Ostland pirates who raid their shores and flee to safe havens in their home islands. However, none of these nations wishes to risk war with Ostland, a strong nation of warriors with the finest navy in the

North. Further, in response to efforts by Vestland and Soderfjord to unite in common interest against Ostland, King Hord has signed a number of treaties with Thyatis, and has allied himself with the emperor in his war against the Alphatian colony of Norwold.

### Society

**The Jarls:** Although there are many powerful and wealthy clans in Ostland, the king retains his authority by taking the finest sons and daughters for his Royal Household. Cnute Clan authority is absolute.

Within individual clans and dominions, the principle of a leader's absolute authority is universally recognized: the jarl's word is law. Questioning authority is likely to result in beatings, slavery, confiscation of property, or death, although recent judgements by Queen Yrsa have mediated some of the worst brutalities.

**Freemen and Thralls:** There are no democratic traditions in Ostland. Freemen are generally farmers and fishermen. They own their land and boats at the jarl's sufferance; their wealth and happiness are directly related to the value of their service to the jarl.

Slavery is legal and common in Ostland. Those born of thralls remain thralls. A jarl may declare a freeman enslaved for any offense, and prisoners of war are made thralls, distributed by the jarl as one of the spoils of war.

### Geographical Notes

**Noslo Island:** The soil is fertile. Spring, summer, and fall are mild. In the harsh winter, violent sea storms threaten shipping, livestock, and shelters. The produce of the good growing lands is augmented by an abundance of fish and good harbors from which to sail. The island is densely populated and most land is under cultivation except for scattered wetlands. The population is dispersed in village-sized clan and family settlements. Despite its agricultural abundance, Noslo Island's culture and technologies are relatively backward by

## NATIONS OF THE NORTHERN REACHES

D&D® Game Known World standards.

**Zeaburg:** The capital of Ostland is home to the Court of Cnute, currently ruled by King Hord Dark-Eye and Queen Yrsa the Young. The Royal Compound itself is surrounded by twenty clan halls, the winter residences of the Great Clans of Ostland. Noble hostages (male or female) remain in residence year-round. (Greater detail on the Court begins on p. 32.)

Approximately one-quarter of the town's population are soldiers, support staff, and camp followers residing in the barracks of the King's Personal Guard. Also within the barrack walls are the Royal Treasury and the Royal Granaries.

Another quarter of Zeaburg's population is associated with the Court or the Great Clan winter residences. The remainder of the town's population aggregates in farming and fishing villages.

Zeaburg is a wealthy but somewhat backward capital. The rich are very rich, the poor are very poor, and the merchant and craftsman middle-class is almost non-existent. Foreign visitors are restricted to a visitor's compound unless they are guests of the royal family. The compound is closely supervised by the king's Personal Guard.

**Zeafort:** Surrounded on three sides by marshy ground, and on the fourth side by the wide shingle where the army's longships are beached, Zeafort is ideally situated for defense and for swift embarkation for offensive raids and campaigns. Built in the last century by the Cnute dynasty, Zeafort is a fortified town where the three brigades of Ostland's standing army are garrisoned.

Three large fortresses, each with sixteen longhouses, are the homes of the Raven, Wolf, and Dragon brigades. Associated with each fortress is an annex—a small fortified town in its own right—where support staff and camp followers live.

The Raven, Wolf, and Dragon brigades have seen frequent action as allies of the Thyatian Empire in their wars with Alphatia, campaigning in the Alphatian colonies of Norwold and the Isle of Dawn. The officers and men of these bri-

gades are veterans with superior morale, and are fiercely loyal to the king.

The War Machine information (as developed in the *D&D® Companion Rules*) for these brigades is as follows:

Unit Name: Army of Ostland  
Type of Unit: Regular Division  
Number of Units: 1  
MV 4, BR 102  
Personnel: 882  
Troop Class: Good  
Special Ability: Can cross ocean hexes (not lakes or rivers) at normal movement rate and can land on any coastal hex not occupied by an enemy unit. All troops are berserkers; they never check morale and always fail discipline checks.  
Division Commander: F9 (CB +1)  
Deputy Division Commander: F8  
Heroes: 6 F15, 6 C8  
Unit 1: 120 elite F3 human infantry, swords and spears, 3 Sergeants (F4), 1 Captain (F5)

**Kalslo Island:** Most of the island is edged by a narrow band of fertile coastal lowland punctuated by fine harbors. Along the western peninsula, unwelcoming rocky seacliffs face seafarers. The interior of the island is a rugged, stony upland suitable only for grazing sheep.

Kalslo's clans are proud and independent, and carefully watched for signs of conspiracy or treason by agents of the royal house.

The official cults of Odin and Thor are less honored here than the cult of Frey/Freyja. Priests maintain several ancient monasteries in the interior and along the bleak western seacliffs. The sacred burial grounds of the early Ostland kings are scattered along these seacliffs. The tombs are guarded by the monasteries, by arcane wards and enchantments, and by the spirits of the restless dead.

**Ostmanhaven:** A rough trading and fishing port, Ostmanhaven welcomes foreigners and adventurers—unlike most Ostland ports.

The lower town offers the same modest shacks, seedy taverns, warehouses, and

markets typical of small ports throughout the world. Natives domesticated giant rats to keep the ordinary rodents under control. Two-legged rats of the human variety also present a serious pest problem, and strangers are advised to keep a sharp eye on their property.

In the upper town are the clan halls of the Ostman clans. The buildings are dwarf-crafted stone well situated on the hills overlooking the bay. The Ostmans have become wealthy from the profits of their merchant fleets. The Ostmans swell their treasuries by piracy, and it's said that the prosperous criminal population of the lower town is organized for the convenience of the Ostman lords.

The Ostmans have never been troubled by the traditional Northman fear and contempt for sorcery. Three clanheads were themselves wizards, and several of the potential heirs of the current clanhead have trained at the Uppsala College of Magic at Norrvik.

Ever at odds with the Cnutes, numerous Ostman nobles have been outlawed for treason. Twice in the last century the Ostman clans rose in rebellion against the Cnute dynasty; twice the rebellions were brutally and efficiently suppressed by the Cnute kings.

**Osterlo and Kunslo Islands:** With almost no arable land, the inhabitants of these rocky islands live from the sea. The people hunt whales and sea serpents in tiny open boats, and are said to be among the finest, most courageous sailors in the Northern Reaches.

Outsiders and foreigners are not welcomed; the Osterlo and Kunslo clans confine their hospitality to kin and friends. Visitors are told to leave, and are attacked if they fail to comply. When threatened with force, the islanders respond with sullen and uncommunicative obedience.

### CURRENT EVENTS

The situations described below are meant to suggest possible adventures to the DM who wishes to create his or her own Ostland-based scenarios.

**The Isle of Dawn Colonies:** Encouraged by Thyatian Imperial representatives, and in spite of threats by the Council of Alphatia, King Hord has authorized the settlement of seven colonies on the northwestern coast of the Isle of Dawn. Three colonies are already established; the other four are in the planning and outfitting stages. With reports of gold and silver discovered in this region, the House of Cnute is ever more eager to move ahead with the program.

Life in the colonies is expected to be dangerous but profitable. Apart from the considerable challenge of the Isle of Dawn's bizarre wildlife, peculiar climate, and hostile humanoid races, the powerful sorcerous agents of the Alphatian Empire and their loyal servants are expected to oppose the establishment of these colonies. Fortunately, most of Alphatia's energies are directed elsewhere at the moment, though that condition might change at any time.

**DM Note:** This is a blank check for sea voyages and wilderness adventures. Any exciting adventures that don't fit your current campaign setting can be stuck off on this isolated island continent.

### **The Contrary Ostman Clans:**

Almost every faction in the North is interested in the fortunes of this small clan. Ostland's enemies wish to heighten the friction between the Cnute dynasty and the Ostmans, weakening the nation overall. Those supportive of national unity would see them reconciled with the ruling monarchs or eliminated.

Asgrim the Bowed has advised the king to abolish the Frey/Freyja monasteries on Kalslo and confiscate their lands and property. With the monasteries out of the way, Hord could establish himself as protector of the tombs of the ancestral Ostland kings—and clandestinely plunder those tombs for the treasures they conceal.

Yrsa's spies have informed her of this plan, which she opposes. She may not work directly against the scheme, but she counsels Hord against overt actions that would divide the nation.

The monasteries have been informed of their peril, and have petitioned the

cult's patriarchs for aid. The monasteries have also sought the assistance of the Ostman nobility, who are loyal Frey/Freyja followers and the traditional defenders of the monasteries.

Some of Hord's jarls have offered to remove the annoying Ostman clans permanently, in return for Kalslo Island as clan domain. Yrsa would work to avert a civil war that would endanger more promising programs like Hord's alliance with Thyatis, and the colonization program. She also has made it clear, through her agents, that the Ostman jarls will be better advised to make common ground with her growing power base than to start an internal war the royal house is quite capable of finishing.

So far, Hord has not answered the jarls who propose this scheme, but certain of his older counselors have secretly encouraged these aggressive jarls to take matters into their own hands. A younger Hord would have acknowledged the exterminators of the Ostman clans as their rightful successors, once the deed were done. The older Hord now on the throne is more capricious, and Yrsa's growing power leaves some counselors unsure of which way to jump.

Finally, several times in the past decade the Ostmans have sent agents to the King of Vestland and to the war leader of the Jarldoms, offering to rebel against the Cnute king if Vestland and the Jarldoms would offer military and diplomatic support. Vestland has consistently rejected these entreaties. The Jarldoms' war leader, Ragnar, has recently agreed to such an offer, subject to his approval of a workable plan and a timetable.

An adventure set here must answer several questions: can the Ostmans trust Ragnar to give the support he promises, or might he leave the Ostmans to fry in their own juices? Can they hope that Vestland will join the fight if they see an opportunity to chastise Ostland? Or is there room for negotiation with the young queen, whose real strength is untested, banking their support now for her protection to come?

The Raven, Wolf, and Dragon brigades, combined with the Personal Guard, comprise an army of 3600. King

Hord can also call on five to ten thousand men from the nobles, guards, and levies of the subject clans. Against such a force, the Ostmans haven't a chance, as evidenced by the bloody suppression of their previous revolts.

But if some brigades were busy fighting elsewhere for Thyatis, if Ragnar delivers a brigade or two of his troops, and if Hord Dark-Eye were taken by surprise, such a rebellion might work. With Vestland's aid, success is even likely.

**DM Note:** The plots and counterplots of the Ostmans, the Cnutes, and their followers can frame an entire campaign of political intrigue, or set up isolated adventures centering around smaller elements of these plots. Consider the following episodes that might be isolated adventures or part of a larger campaign:

- A PC cleric, a follower of Frey/Freyja, is sent in disguise to Ostmanhaven to deliver a parcel (a cult relic and magical device) to a certain party. That individual, disguised as a thief and pirate, is actually a henchman of the Ostman clan chiefs.
- Marked by King Hord's men as possible agents of the Ostmans, the PCs are pursued and attacked as King Hord's agents try to discover the PCs' role in the growing conspiracy.
- The PCs are rescued or contacted by agents of Ragnar, who wish to use them as couriers. Yrsa's agents intervene, portraying Ragnar as an outsider intervening in another nation's internal politics—and presenting Yrsa as the force of Ostland's future, able to enrich those who stand by her now.
- Hearing of Hord's plans to confiscate and plunder the monasteries and ancient tombs, the PCs are sent to aid the Frey/Freyja clerics, and to enlist the aid of the restless dead who guard the tombs of the ancient sea-kings.
- Pretty soon, agents of Vestland, Ostland, the Ostmans, Queen Yrsa, Thyatis, Alphatia, the various cults, and the Continental Insurance Company begin to line up in the halls outside the PCs' rooms, waiting their turn to scheme with or whack on the increasingly bewildered PCs. The choices the PCs make might just change the face of Ostland forever!

## NATIONS OF THE NORTHERN REACHES

### Vestland

**GOVERNMENT:** Vestland is a modern monarchy, with a strong feudal aristocracy. An influential middle-class is developing the urban economy, and a proud military tradition, based on a well-trained yeoman militia, defends the country.

**Ostland Forebears:** Though a few barbarian clans survived the Nithian occupation of Vestland, the mainland was essentially unsettled when Ostland colonists arrived in the sixth century AC. Cnute's sons and their followers found a harsh country with scarce agricultural land, threatened by troll tribes in the north and giants raiding in the west. For decades these Ostlanders joined with the local tribes to secure their frontiers from monstrous attacks.

**Ottar the Just:** For over a century the Vestland colonies remained under the rule of the Ostland kings. However, the greedy demands for tribute and the casual indifference to requests for aid against the trolls and giants eventually drove the Vestland jarls to declare their independence.

Ottar the Just, a descendant of Eirik Cnute, led the Vestlanders in rebellion. Ottar's forces—a motley group of jarls and frontier freemen—were no match for the Ostland armies in a straight fight, but in defense of their homes and steads, the Vestlanders were formidable indeed. Frustrated by the staunch resistance of the rebels, King Finnbogi of Ostland launched an ill-conceived invasion. Denied supplies by Vestland raiders, Finnbogi's campaign stalled, then turned into disaster at the Battle of Bridleford where a bold raid captured the king and many of his allied jarls.

The descendants of King Ottar continue to rely on a strong yeomanry defending Vestland's security. Vestland is accurately regarded as weak in offensive military capability, but its Home Guard is exceptionally effective patrolling its frontier borders and discouraging Ostland pirates and raiders.

Further, the Vestland kings of the

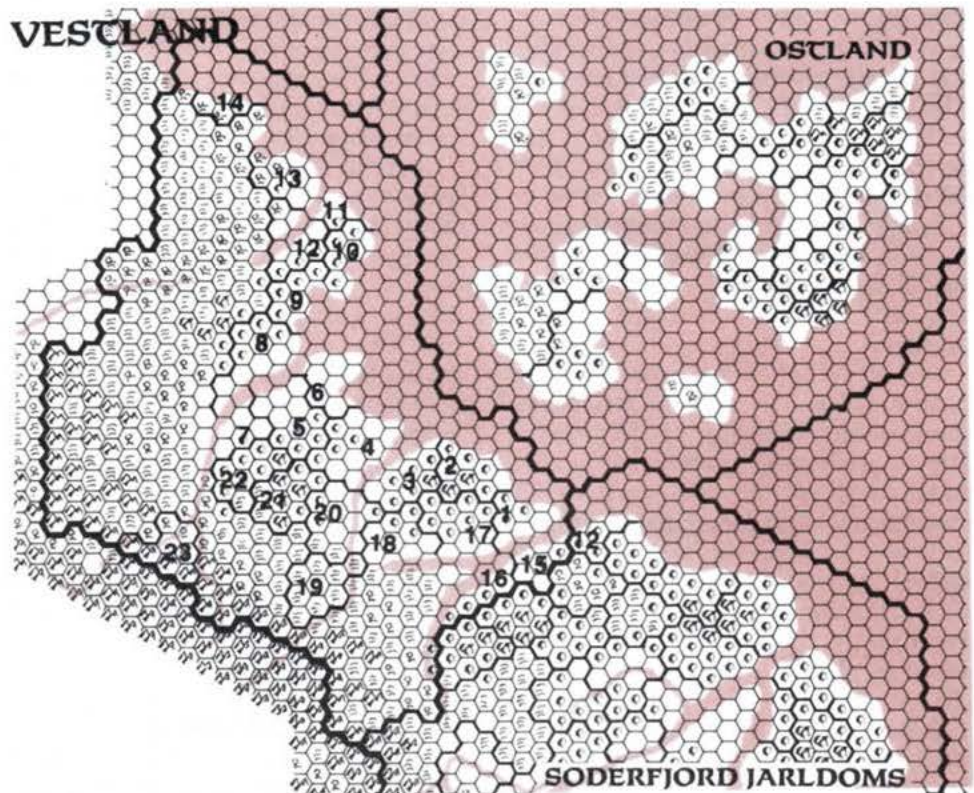

House of Ottar have pursued government and social policies which have made Vestland a growing economic power in the North. Support of craft guilds and foreign commerce have made Vestland wealthy. Its townsfolk are as happy and prosperous as may be found in the Known World, and many craftsmen, farmers, and fishermen benefit from the high prices their goods earn in local and foreign marketplaces. Vestland's open society has also encouraged an influx of foreign settlers (most notably, Rockhome dwarves), enriching Vestland's culture and technology.

**The King and the Royal Council:** King Harald Gudmundson is advised by a council of royally-appointed figures representing the nation's significant interest groups: the nobles, the craftguilders, the trade merchants, the freeholders, the cult of Frey/Freyja, and others. To maintain the goodwill and cooperation of a people traditionally vigorous in defending their rights, the king must be fair when selecting the represent-

atives, and prudent to acknowledge the Council's interests and advice in policy matters.

This is the practical model for most town governments in Vestland, where the mayor is selected by the king or a local jarl, and a council is selected to represent local interest groups. In rural and frontier areas, the clan leader and his subordinate jarls are the authority.

**The Home Guard:** The Home Guard is a sort of police force established and funded by the king, with three responsibilities: protecting the coasts from raiders; patrolling the frontier borders against monster raids; and training and drilling the local militias. Poorly-paid, undermanned, and dependent on local communities for food and support, service in the Home Guard is regarded as the duty of every young Vestlander—and an opportunity for travel and adventure.



## NATIONS OF THE NORTHERN REACHES

### Kingdom of Vestland: Dominions and Major Settlements

Hex #	Domain	Area sq. mi.	Pop.	Major Settlement/Pop.
1.	Hostmore	165	3000	Hostpork, 1000
2.	Valgard	305	3000	
3.	Grosfold	415	7000	
4.	Marsfjord	360	9000	Dremmen, 2500
5.	Sveamark	525	25,000	Norrvik, 9000
6.	Fosterhead	195	5000	
7.	Ranviki	275	6000	Bergen, 2000
8.	Falsterholm	385	7000	Namsen, 1000
9.	Fynmark	250	5000	Sudorn, 1500
10.	Jamtford	250	3000	
11.	Namahed	165	4000	Tromso, 2000
12.	Verfjord	335	5000	
13.	Skansiscost	415	7000	
14.	Norrland	125	5000	Dovefell, 2500 Seaforth Tower (X13)
15.	Hrutmark	250	2000	
16.	Bornbank	235	3500	Vanger, 1000
17.	Brandholm	555	4000	
18.	Hennesdalir	470	6000	Helega, 2500
19.	Landersfjord	445	10,000	Landersfjord, 5000
20.	Haverhold	500	12,000	Haverfjord, 4000
21.	Uplands	500	7000	
22.	Hallmark	445	7000	
23.	Rhoona	500	12,000	Rhoona, 5000
24.	Wilderness	13,000 +	1000	
	<i>Total</i>	<i>21,065 +</i>	<i>161,000</i>	

**Vestland's Policies:** As mentioned above, crafts and trade (both local and foreign) are encouraged. The House of Ottar has also supported the study of classical spellcasting. The only College of Spellcasting in the Northern Reaches is in Norrvik, but standard apprenticeships are common elsewhere. Spellcasters are common in small towns. Witchery and other, more primitive magical arts are practiced mainly in the borderlands and rural communities.

The kings in Norrvik have long encouraged settlement of the Trollheim hills, but only recently has King Gudmundson been able to support expeditions and border garrisons in the area. The trolls are organizing in response, putting Vestland on the defensive.

Concerning its relations with other nations, Vestland maintains cordial political and trade relations with Soderfjord,

Ylaruam, Ethengar and Rockhome. Some factions favor an alliance with Soderfjord against Ostland to discourage Ostland raiding. Currently, the king is avoiding open conflict with Ostland.

### Society

**The Jarls:** In the urban areas, Vestland's aristocracy has gracefully resigned its position of power for a position of wealth and honor. In rural and frontier areas, the jarls remain the unquestioned authority in the clans, though abuses of authority are unusual.

**Freemen and Thralls:** Free merchants and crafters control much of Vestland's wealth, and thus they wield considerable influence. Craft and merchant guilds are very powerful in the towns. Vestland's farmers and fishermen are a proud and independent lot, honored and respected by the clan leaders.

Slavery is illegal and immoral in Vestland. The urban poor live wretched lives, as they do elsewhere, but the rural poor are cared for by their community and by the cult of Frey/Freyja.

**Dwarves in Vestland:** Many young dwarves have settled in Vestland communities to provide artisan skills. Their skills are in demand, and they can grow prosperous outside the rigid clan system of Rockhome.

However, there are also many outcasts in the dwarven quarters of larger towns, where the toughs work as laborers—when they take a regular job at all. Drinking problems are common. Some dwarves hire out as mercenaries or bodyguards, or they drift into the underworld cultures. Among the ignorant and uncouth there is much prejudice against dwarves, who are perceived either as greedy and rich, or violent and uncouth.

### Geographical Notes

**NORRVIK:** The capital of Vestland is the most cosmopolitan town in the Northern Reaches. A large modern city on the Vestfjord River, Norrvik has vigorous trade and craft centers, a great secular and magical college, and a large dwarven quarter.

**Vestfjord:** This broad waterway leads from the ocean through the Makkres Mountains to the Rockhome interior. The river is navigable year-round by most vessels as far as Rhoona. Beyond Rhoona, the river is navigable only in the summer and early fall, and then only by skilled raftsmen or by the occasional longship.

**The Overland Trade Route:** This road connects the Vestland ports and southern trade routes with Rockhome, Ethengar, and the west. In Vestland, the road is well-patrolled by the Home Guard, but is not entirely free of bandits. Giants are occasionally encountered along the road west of Rhoona and near the border with the Jarldoms, but otherwise the route is pleasantly free of monstrous peril.

In settled areas, there are numerous

## Nations of the Northern Reaches

small inns along the road. Small groups of travelers are often welcome in private dwellings, but local people are less generous with their hospitality than in other regions of the Northern Reaches, because of the heavy traffic along this road.

In the borderland and wilderness areas of the western and southern hills, there are shelters for caravans and travelers. The shelters are maintained at regular intervals along the road, and some are fortified. A few of these shelters are garrisoned by the Home Guard, but most are untenanted. Many shelters are protected by cult shrines, where powerful protective runes have been inscribed for the use of itinerant clerics.

**RHOONA:** This busy, dirty frontier town on the Overland Trade Route is an important port for trade goods. Caravans move through Rhoona on their way to and from Rockhome and Ethengar in the west, and along the road to the major ocean trade routes in the east. Rhoona is also a common starting point for treasure-hunting expeditions into the Makkres Mountains.

The head of the Rhoona clan styles himself as a 'duke' after the southern fashion, and maintains a lavish, courtly lifestyle in a dwarf-built palace on a hill overlooking the town. The palace is as yet only partially complete, often delayed by the Duke's distressed treasury, but it is said to be protected by various complex traps engineered and built by dwarves. Construction on the building continues erratically.

Most of Rhoona's large dwarven population resides in the quaint and squalid section called "Old Town." Old Town has more than twenty taverns, and the local breweries produce better-than-average quality lager and ale. On days when the dwarven construction workers at the Ducal Palace get paid, Old Town swarms with strong, cheerful rock-choppers with a powerful thirst for suds. Old Town sees more than its share of drunken dwarven brawls, and the thugs and lowlifes gather as thick as the skull of a hill giant.

Rhoona's Ethengarian district is populated mostly by merchants who deal in horses and goats, and by the nomads who

bring their livestock to Rhoona for sale and trade. The Ethengarian district is said to be a hotbed of evil schemes and intrigue, with the rumors centering around the Cretia cult temple and its clerics.

(The town of Rhoona is treated in detail in *The Curse of Xanathon (X3)*, a D&D® Expert Adventure module.)

**TROLLHEIM:** The high granite moors and rugged wooded valleys of Trollheim have been occupied by trolls for centuries. For the last three decades, King Harald and the Royal Council have encouraged settlement in this area, under the Trollheim Homesteading Acts.

The Homesteading Acts originally seemed to be a simple standard procedure one might follow to develop the wild lands. The king and Council began by conferring a land grant to an eager entrepreneur, who got the title of "duke" and owed loyalty directly to the king. The new duke would send in an armed expedition to drive away the resident trolls and, as soon as possible, build a fort that doubled as the ducal residence.

Unfortunately, the dukes generally failed to occupy or garrison the forts, and few were persistent or effective in keeping the trolls out of their new dominions. Settlers who moved into these regions, clearing land for their sheep farms and building fortified steads, often found themselves unprotected from troll raids.

Worse yet, after three decades of ruthless extermination by the humans, a small but dangerous minority of trolls is now beginning to catch on to the art of modern warfare against human foes. Isolated steads are assaulted by well-led troll raiders. Before neighbors or Home Guard garrisons can rally in defense, the raiders have destroyed the stead and slaughtered its inhabitants, then withdrawn into the back country where they can easily elude trackers.

The disastrous failure of the Trollheim Homesteading Acts is a scandal and embarrassment to the king and the Council. The ducal titles and land grants have been rescinded, and charges of treason have been brought against the most negligent entrepreneurs. The royal treasury has been opened to fund expeditions

to pursue troll raiders all the way to their hideouts. Units of the Home Guard have been dispatched to occupy, rebuild, and garrison the former ducal estates.

**SUDORN:** This seaside community is the market town for the whole north coast of Vestfjord Bay. Clan warfare decimated the population of this region in the eighth century AC and feelings still run hot in the area. Blood feuds are common, even drawing in casual travelers who unwittingly slight a touchy clansman.

In the hills to the northwest are the shattered remains of several clan halls and monasteries. Isolated shrines in the region, falling into ruin, bear unfamiliar runes of unknown origin. Natives to the area believe these sites to be haunted, and everyone has a tale to offer.

Trolls, mostly absent from this region for the last four centuries, have been sighted more frequently, scouting near remote lowland steads. As yet, no raids have occurred, but the farmers in the area are nervous and have requested a detachment of the Home Guard be brought in as a precaution.

**TROMSO:** This community centers around the clan seat of the powerful Namahed clan, a clan which claims to bear elven blood. The Namahed clan is ruled by Eyvind the Odd, priest of Odin. He is so called for his vaunted powers of the Sight, and for the fits and trances during which he receives his visions. The ruling family has a new clan hall, built in stone by dwarves, with tunnels leading back into the cliffs above the town.

Tromso is the major depot and outfitting point for expeditions headed up the Nordesfjord into troll country.

**DOVEFELL:** This is a small but prosperous fishing and whaling village. The hills to the south are rich in minerals, but the rough terrain and the menace of trolls prevent exploitation of the resources.

**HAVERFJORD:** This bustling town is an important trading center on the Overland Trade Route. The political climate is touchy. Recent decisions by Leif the Lean,

## Nations of the Northern Reaches

clanhead of Haverhold, are alienating Bifurr Mim (the dwarven mayor), the town Council, and unsettling the wealthy merchants of the town.

Leif admires the conservative values of the Ostlanders, and seeks closer ties with the Ostman clan of Noslo Island. He has offered his daughter in marriage to a young scion of that clan.

Now Haverfjord is experiencing a crime wave, brought on by a well-organized crime network that has sprung up in this previously sleepy town. The local folk blame it on the closer relations growing between the Haverhold clan and the Ostman clan and the populace is pressuring the mayor and Council to protect them, since the clanhead will not. Merchants know the shady reputation of the Ostman clans, and see pirate raids increasing on local shipping. They are becoming reluctant to move their goods through the area, to the detriment of all.

**VANGER:** This muddy market town serves the southern shore of the Landersfjord River. Sovereignty of this region has been disputed by Vestland and the north-border clans of the Jarldoms.

Ragnar the Stout, war leader of the Jarldoms, desires no conflict with Vestland at this time, but the clanheads of Haltford, Boddergard, and Hillgard covet the neighboring domains of Hrutmark and Bornbank, and they willfully disregard Ragnar's authority.

These clanheads stir up trouble with the Bornbank clan, hoping to spark a border war. Then the clans would call on Ragnar for troops, confident that the war leader would help them rather than risk losing the support of the other jarls of Soderfjord.

**LANDERSFJORD:** This frontier and trade town on the Overland Trade Route is also a deep-water port on the Landersfjord River. Arnulf Burison, head of the Landersfjord clan, is also the mayor of the town. Arnulf has encouraged wealthy merchants and adventurers to build rich manors in town with the promise of cheap dwarven labor and engineers, and building stone made easily available

through the deep-water port. Modern in his views on sorcery, Arnulf has a number of skilled wizards on retainer, and is himself a famed adventurer and giant-killer.

Arnulf's dream is to build a city to rival Norrvik in wealth and sophistication. To that end, he seeks to found a college of magic, with a collection of tomes and artifacts to rival the library of Uppsala College in Norrvik. Arnulf and a group of wealthy backers (merchants, adventurers, and cult temples) are buying noteworthy spell books, tomes, scrolls, and magical items for top prices.

Accommodations and services in town are abundant, and varied in cost and quality. Expedition outfitters are well stocked, and some will recommend guides available for backcountry adventuring. A message service and expedition clearinghouse, located at the Council Hall, offers counseling and choice rumors for treasure-hunters.

### CURRENT EVENTS

These events are intended to serve as a framework on which a DM may develop his or her own Vestland adventures.

**TROLLHEIM:** The lands affected by the Trollheim Homesteading Acts lie in the easternmost section of hill country between Dovefell in the north and Namsen in the south. These lands have been partially mapped and settled, though in the last decade many settlers have left their steads or been driven out by troll raids. The hill country west of these lands is uncontested troll country, largely unexplored.

Warriors, spellcasters, and other adventurers are sought for service in the Home Guard. Units for the protection of this region are being formed in Sudorn and Tromso. Enlistees are promised a substantial cash enlistment bonus and a land grant in Trollheim at retirement. Short-term enlistments for cash are also available.

Mercenary units are being hired on a single-mission basis for operations and campaigns in this region. Interested captains must meet with Eyvind the Odd in

Tromso, or with Rurik Sturlason in Sudorn—these jarls coordinate the overall campaigns in the king's name. Eyvind and Rurik have royal funds available for payment and outfitting of mercenary units. Missions include scouting the frontier and pursuing troll raiders into the back country.

**VANGER:** Rotolf Kalfson of Bornbank clan has warned Guthorm Brittle-Bone of Soderfjord's Boddergard clan that any further raids by men of Boddergard will be regarded as an act of war. Rotolf has sworn in a message delivered to Guthorm, "If provoked again, I will pursue your cowardly dogs to the door of your Hall."

Rotolf is hiring mercenaries, and accepting freemen into his service as clan warriors. Men accepted as clan warriors are officially adopted into the Bornbank clan, and entitled to the obligations and hospitality of its hearths. Rumor indicates that Rotolf is not being fussy about accepting outlaws, clanless men, or foreigners into his service and clan.

**LANDERSFJORD:** Arnulf Burison has offered a reward for the recovery of two enchanted headposts, carved with runes and decorated in gold and silver, taken from the death ship of an ancient royal tomb. The headposts disappeared from Oland's Rest, an Odin monastery in the hills west of Landersfjord, where they had been taken for study. The posts were reportedly sacred to Odin, and bore rune variants previously unknown.

## NATIONS OF THE NORTHERN REACHES

### SODERFJORD JARLDOMS GOVERNMENT

For the past three centuries the Soderfjord region has been divided into a number of minor nations, each ruled by a powerful clan. From time to time, one jarl would overrun several neighboring lands and proclaim himself king, whereupon the other jarls would get together and thump the living daylights out of the self-proclaimed king. Then the jarls would fight among themselves a bit until everybody was very tired. In the end, things were pretty much the way they began, only lots of people were dead, and plenty of villages and farms were burned to the ground.

For variety, a few Ostland jarls would sail over occasionally, kill a lot of people, burn villages and farms, and proclaim themselves kings. Then they would steal everything they could load in their boats, and sail back to Ostland while the Soderfjord jarls were arguing about who was entitled to lead their noble kin in defense of their homeland.

After several centuries of this sort of warfare and devastation, the nobles of Soderfjord realized that their only hope lay in some more effective form of cooperation.

**The Nordhartar Defense League:** At the Council of Soderfjord in 950 AC, representatives of the most powerful clans of the region signed the Treaty of Allied Dominions, forming the Nordhartar Defense League. Those who signed, and their descendants, are sworn to answer the summons of the "war leader" (chosen by a Council of the Great Jarls) in the defense of the lands of the treaty-signers. In the past half century, the successors of the signers have on the whole remained loyal to the League.

The war leader has broad powers to compel cooperation in matters concerning the defense of Soderfjord against external aggressors (like Ostland pirates) and internal threats (like unruly clans, raiding monsters, and bandits threatening the Overland Trade Route). He has no other official powers.

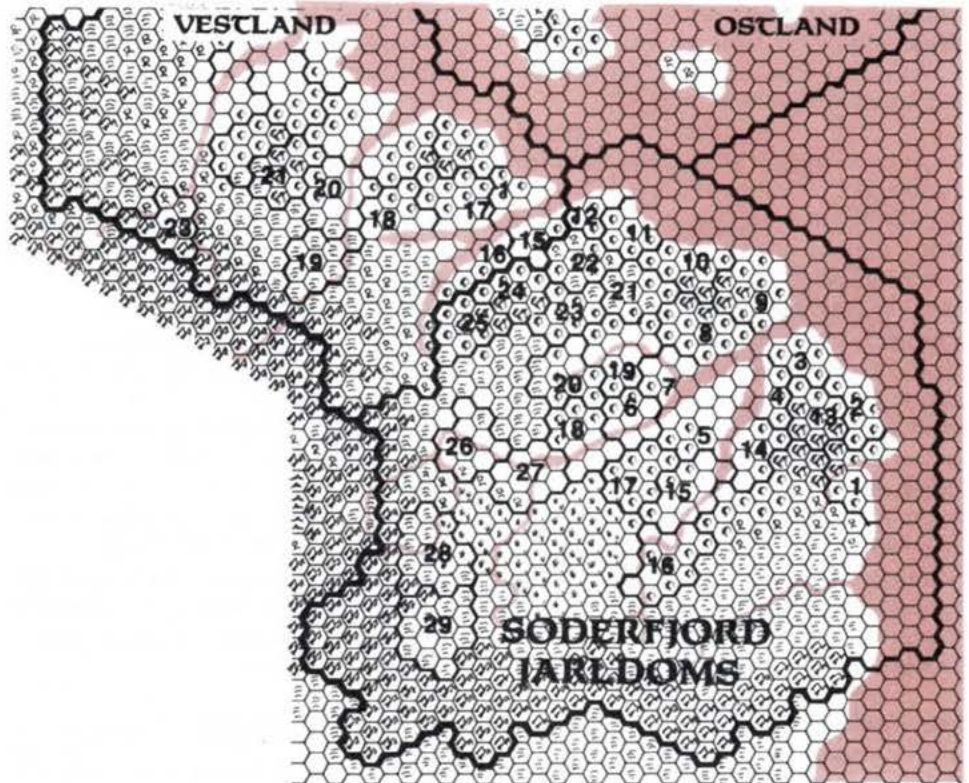

The Council, comprised of the ruling jarls of all the dominions of Soderfjord, meets twice a year to select or confirm the war leader, and to discuss other matters of national defense. The Council also has the power to discuss and ordain laws concerning Soderfjord and its people, but it has no authority to enforce those laws. The jarls and the clanheads remain the only recognized authorities in Soderfjord's various dominions. Law and justice depend on the power, character, and will of the local jarl.

The motivations of Ragnar the Stout, the current war leader, are both ambitious and patriotic. He enjoys the wealth and power of his position, but he also believes that the Jarldoms must become a modern, unified nation in order to avoid being swallowed up by Ostland and Thyatis. He is willing to employ any means—persuasion, diplomacy, or despotic ruthlessness—to achieve his aims.

**The Freedom Brigades:** Established, organized, and supervised by the war leader, these units are a loosely orga-

nized militia. Each brigade is a group of sub-units organized under a single jarl. Some brigades from the larger settlements receive regular militia training, but most are nothing more than the commanding jarl's retainers and the battle-trained freemen from his region. Politics between the Brigades are fierce and disruptive but, thanks to the Northlanders' warrior traditions, the Brigades are moderately effective in combat.

**Policies of the Soderfjord Jarldoms:** The people of Soderfjord still honor the democratic principle of the *thing*, a Northman tradition. The *thing* is an annual or semi-annual public gathering where any freeman is invited to speak out in favor of laws or policies concerning local or national affairs. No laws can be established without unanimous agreement of those in attendance, and there are no provisions except social pressure for enforcing those laws which are established.

## NATIONS OF THE NORTHERN REACHES

### The Soderfjord Jarldoms: Dominions and Major Settlements

Hex #	Domain	Area sq. mi.	Pop.	Major Settlement/Pop.
1.	Olvasfjord	415	5000	Wilmik, 2000
2.	Suddland	335	3500	
3.	Hordamark	275	6000	
4.	Heddesfjord	220	8000	
5.	Soderfjord	555	18000	Soderfjord, 7000
6.	Vithesfeld	335	8000	
7.	Bergholm	305	2000	Dorna, 2000
8.	Vastergard	525	9000	
9.	Rogaviki	500	6000	
10.	Vandermark	360	7000	
11.	Haltford	195	6000	Morden, 3000
12.	Borkmark	140	2500	
13.	Moderfeld	390	1500	
14.	Oberbeck	275	2500	
15.	Rurrland	610	2000	
16.	Ozurfold	610	1500	Whiteheart, 750
17.	Gudholm	500	5000	
18.	Hedden	500	15000	Backwater, 3500
19.	Dealand	555	2000	
20.	Hadmark	555	3500	
21.	Highland	445	5000	Highhold, 2000
22.	Hillgard	445	4000	
23.	Ranholm	445	2500	
24.	Hodderland	445	2500	
25.	Boddergard	500	3000	Ranwood, 1000
26.	Otterland	555	1500	
27.	Gretmarsh	525	2000	Sortfeld, 500
28.	Nordcastel	775	8000	Snowvale, 2000
29.	Castellan	775	15000	Castellan, 6000
	Wilderness	18000 +	3000	
	<b>Total</b>	<b>31065 +</b>	<b>160500</b>	

The *thing* is a respectable form of primitive democracy, but it is poorly equipped to cope with the problems of a modern nation. Thus, Soderfjord remains a nation of lofty, admirable principles—and primitive, ineffective government.

Little is done in Soderfjord as a whole to encourage the internal affairs of trade or industry. Its people are traditionally independent and self-reliant in craftsmanship and the skilled trades (including spellcasting). As with all else, the local jarls make local choices.

One cooperative effort being attempted is the Sodervirk. The Sodervirk is a defensive wall under construction in the southeast hill region to protect settlers from the hill gnolls tribes.

Under-funded, the Sodervirk is a political nightmare. The local dominions are expected to pick up the costs, provide the labor, and garrison the forts that should be built every four or five miles along the wall. Few clans are interested in this dubious privilege, and only Jarl Vandrad Horikson of Ozurfold has made any headway with the project.

**DM Note:** This would be a tough but exciting spot for a Dominion Grant to be given to a D&D® Companion noble.

Soderfjord is widely viewed as the “doormat” of the Northern Reaches. A young nation with a weak government and a history of divisive internal politics and warfare, the Jarldoms can do little to dispell this impression. Many jarls and clans are under the open or secret influ-

ence of various factions in Vestland, Ostland, and other nations—nations that treat Soderfjord with a certain skepticism and distrust.

Soderfjord's closest ally is Vestland, though Ylaruam maintains friendly relations to protect its trade interests. Ostland is openly scornful, permitting its clans to raid Soderfjord without restraint. The Court of Cnute has shown no intention, however, of planning conquest or invasion.

### Society

**The Jarls:** The presence of many individually powerful and uncooperative clans and ruling jarls make for complex and bitter politics. Blood feuds and unlawful raiding are common, and many legal disputes between clans remain unresolved.

**Freemen and Thralls:** The common freeman enjoys a greater respect here than in Ostland or Vestland. Freemen tend to honor the authority and politics of their clan leaders, particularly where inter-clan disputes are concerned. Even in towns, the clan is still a strong social bond and obligation.

Slavery is illegal, and it is dishonorable to claim ownership of another person. Nevertheless, a few powerful jarls hold their households in virtual slavery, through the intimidation of housecarls and bully-boys. Such jarls are despised, but interference by the war leader or by other jarls would be unlawful, and would risk confrontation with these powerful, ruthless nobles and their warriors.

### Geographical Notes

**Soderfjord:** This sprawling, squalid town has an excellent river harbor and an unsavory reputation. Soderfjord is guarded by Ragnar's Fort, a fortified island in the river opposite Soderfjord Beach, the Jarldoms' primary trade center.

Ragnar's Fort is the sometime residence of Ragnar the Stout, war leader of the Jarldoms, and commander of Ragnar's Brigade, a 900-man unit garrisoned at the fort. The Council of Soderfjord meets in the fort twice a year.

## Nations of the Northern Reaches

**The Nordhartar Defense League:** As war leader of the Jarldoms, Ragnar the Stout also has the power to muster three other 900-man units from the Great Clans of Soderfjord, as established under the Treaty of the Nordhartar Defense League. These units are obligated to assemble at forts in Morden, Backwater, and Castellan within three days of receiving the summons. Unfortunately, only the fort at Castellan is complete. Construction of the other two forts has been delayed because of insufficient funds. Furthermore, problems of communication, transport, and internal politics make it doubtful that the units of the Defense League could operate successfully in defense of the Jarldoms, much less in an offensive war.

**Castellan:** Castellan is a clean, modern, well-run town, dominated by trading and commercial interests. These interests support Ragnar the Stout, the Council of Soderfjord, and the nationalist principles they stand for, believing that Soderfjord's future lies in becoming a modern trading nation.

Castellan more resembles a mountain town of Karameikos or Glantri than a Northland settlement. The newly-built fort is of dwarven design, with square stone walls rather than the palisaded circular ramparts common in Northland forts. A few wealthy merchants and most of Dwarftown live in stone buildings, and the rest of Castellan's population lives in timber and plank buildings with slate roofs, rather than the thatched roofs commonly found elsewhere in the Northern Reaches.

In custom and lifestyle the Castellans are more cosmopolitan than most Northmen. Dwarves are a large minority, and Ylari faces are a common sight. The caravan district offers pleasant accommodations to fit all purses, and several Ylari, Rockhome, and Northland trading companies maintain offices here.

In addition to regular caravan traffic coming through the Jotunvalk Pass and along the Overland Trade Route, Castellan also welcomes adventurers and treasure-hunters bound for the Makkres

and Hardanger mountain wildernesses. The fabled subterranean kingdoms of the gnomes are powerful lures for those seeking magical artifacts, despite the savage, ruthless kobold tribes said to guard those treasures. The mountains to the west and north of Castellan are also home to fierce giants and the reclusive Modrigswerg, two likely prospects for those seeking adventure and plunder.

**The Snowvale Valley:** A green and fertile upland valley, Snowvale also provides excellent grazing. The section of the Overland Trade Route through this valley is secure and well-patrolled, but the mountains rising east and west above the valley are kobold country.

**Jotunvalk Pass:** Subject to violent weather and too rugged to patrol effectively, this is the most dangerous fifty-mile stretch of the Overland Trade Route. Caravans commonly take on extra guards in Castellan and Cinsa-Men-Noo (Ylarium) for the trip through this pass. Hill giants, kobolds, and common bandits are the most common intelligent menaces. When bad weather forces a caravan to camp in the pass, monstrous predators of various species present an even greater threat.

**The Overland Trade Route:** This vital land trade route is patrolled in Soderfjord by mercenary units funded and supervised by the war leader. Nonetheless, bandits and non-human raiders are a constant threat. Patrols generally include four to ten fighters, and clerics of 1st-3rd level.

In the lowlands and settled regions, these patrols are a moderately effective deterrent to bandits. In wilderness regions like Jotunvalk Pass and the Great Marsh, patrols are encouraged to avoid encounters wherever possible, and they are forbidden to pursue bandits, raiders, or monsters beyond the caravan road. The morale and training of these patrols is unreliable, and they have been known to abandon travelers to their fates when confronted by superior numbers or sorcery.

**The Great Marsh:** These vast, sparsely-inhabited wetlands south of Backwater are dotted with isolated islands of fertile farmland. Yet even the best roads are almost impassable in the spring rainy season, and inhabitants are rare.

The natives of surrounding settlements tell tales of witches, demons, and horrible beasts lurking beneath the surface of the dark swamp waters. The Marsh Road, a one-lane road of parallel logs laid through the swamp, is ordinarily considered safe by day, but there are only four overnight shelters along the route, over ten miles apart. These shelters are fortified and garrisoned. Camping in the swamp outside of these shelters is considered foolhardy.

See "Travel on the Overland Trade Route," page 62-63, for more details about the route and its shelters.

**The Coastal Plains:** The High Coastal Plains are a grassy plateau along the northeastern seacoast of the Jarldoms, suitable for farming and grazing. The Southern Coastal Plains are somewhat more rocky, but otherwise similar. Low cliffs drop sharply into the sea, making it difficult for ships to land except at occasional coves along the coast. Local lookouts are often stationed at the accessible coves, and when raiders do come, the populace gets a warning and some time to prepare. The region is therefore partially protected from sea-reavers' raids.

The clans in these regions are poor, proud, and belligerent. Feuds, vengeance raids, and small wars are common here, and the people hostile and ungenerous. With several centuries' history of clan warfare, these people now depend only on their blood kin for all support and aid. There is little hope of these clans uniting for abstract principles, to become a single nation under a central leader.

Ragnar has encouraged Halfden Greybeard of the Haltford clan to bring the High Plains clans under his control, by force or diplomacy. Ragnar is skeptical of Halfden's loyalties, but considers him the most promising candidate to draw the clans together.

## NATIONS OF THE NORTHERN REACHES

Ragnar himself seeks to unite the Southern Coastal clans under his own Soderfjord clan's dominion, if he can maintain his hold on the title and powers of war leader at the same time. Only his considerable charisma and diplomatic skill will give him a fighting chance to bring these quarrelsome clans together.

**Saltfjord and Otofjord Rivers:** Half of the Jarldoms' population lives in the narrow, fertile lowland valleys along these great rivers. The clan leaders of this region are more or less supportive of Ragnar, the Council of Soderfjord, and the principles of the Treaty of the Nordhartar Defense League.

**The North Border Clans:** The Haltford, Boddergard, and Hillgard clans offer scant loyalty and support to the war leader and the Council of Soderfjord. These strong clans feel they have little to gain by close association with the clans of the High Coastal Plain and the Snowvale Valley. Guthorm Brittle-Bone, the shrewd and opportunistic leader of this political power group, cares little for the vision of the Jarldoms as a modern nation. His maneuvers are planned to satisfy his own political ambitions, which include annexation of the lands of the Vestland Bornbank clan.

**The Hardanger Mountain Range:** This exceptionally hostile alpine

region is uninhabited by humans. The Northland gnome culture inhabited natural limestone caverns and artificial underground habitations in this region for several millennia, only to be exterminated by invading kobold tribes around 490-300 BC.

The present tenants of these underground complexes, the kobold successors, have scavenged among the artifacts and technologies left by the gnomes, producing a remarkably high level of culture for such primitive humanoids. For centuries, there has been little contact between the Northland human culture and the Hardanger kobolds, but recent developments suggest that that situation is about to change.

**The Gnollheim Hills:** This high plateau is scored throughout by deep, winding, V-shaped river valleys. The flat hilltops, rising to two and three thousand feet above sea level, are covered with mixed grassy meadows, and scrub and pine forests. Dense growth covers the steep valley sides, right down to the rocky streambeds of the fast-moving watercourses.

This rugged terrain is inhabited by the nomadic hill gnoll tribes. In the summer, the mountain goat herds graze the high pastures; in the winter, when snow covers the high plateau, the gnolls drive their livestock into the low valleys on the northern and western margins of the region.

Relations between the gnoll tribes and the human settlers of the Whiteheart Valley have never been friendly. Attacks on settler steads have been frequent, and punitive raids are made, in turn, into gnoll territory. Construction of the Soderfjord along the edge of the gnolls' traditional winter pasturage has pitted the humans against the gnolls in a struggle for control of these lands.

The Soderfjord itself, a partially-completed stone-and-earth wall along the eastern edge of the Whiteheart Valley, stretches for thirty miles through former gnoll pasturelands. The eighteen small border forts, only six of them complete, are undermanned and of dubious tactical value against the gnolls, who prefer brief raids to open confrontation. In retrospect, many feel that the wall has done more to provoke the hostility of the gnoll tribes than to ensure the security of the Whiteheart settlers.

**The Ostfold Scarp:** The Gnollheim hills and the Hardanger Range meet the ocean in a series of spectacular 300 to 500-foot sheer cliffs that run from the Ylari border in the south, to the Stone River in the north. Broken only by the deep gorge of the Angesan River, these sea-cliffs are scalable only by sorcery or unthinkably risky mountaineering.

One section of cliffs, thirty miles south of the mouth of the Angesan, is marked with vast panels of hieroglyphs engraved



## NATIONS OF THE NORTHERN REACHES

into the black, durable cliff face. The scale of this undertaking is magnificent, with some sections of engravings over two-hundred feet wide. Antiquarian experts suggest that these markings may represent the recorded history of some long-dead civilization. In fact, the hieroglyphs are Nithian histories, and the cliffs are the burial district for the middle dynasties of the Nithian Empire. The entrances to the tombs are concealed by engineering and sorcery, although keys leading to the location of the various tombs may be deduced from the hieroglyphic inscriptions.

At present, the key to translation of these hieroglyphs is lost, and attempts at magical translations have been to no avail. The Rosetta Stone to unlock the meaning of these glyphs may be discovered in ancient Nithian ruins scattered along the eastern coast of this continent, from the islands of Ierendi to the Alphanian colony of Norwold.

### CURRENT EVENTS

Enterprising DMs should use the events outlined below as frameworks on which to build their own adventures in the Soderfjord Jarldoms.

**The Witch-Queen of Hel:** The best known legend of the Great Marsh is that of the Curse of Carrah, the Witch-Queen, an ever-living servant of the Queen of Hel and master of the Paths of the Dead.

Carrah cruises the waters of the swamp at night in her *faeting* MarshFire, with her four undead serving men at the oars. She searches for brave volunteers to walk the Paths of the Dead with her in search of her lost husband, Dunedhel. Dunedhel, an elf, also served the Queen of Hel, but he strayed from the Path and became lost in the icy otherworld of Niflheim. Carrah offers the Gift of Knowing to any who will aid her.

Carrah is said to appear to any who call her name at the dark of the moon while standing on the Red Rock, a well-known local landmark, a lump of red sandstone rising above the swamp in the foothills

south of the caravan route.

Gudrun Goat-Shoe, fifth son of Hakon Bloodaxe, a Hedden clan noble in the Personal Guard of Ceowulf War-Tooth, clan chief of the Hedden, has disappeared. His brothers admitted that they had mocked his courage. In challenge, Gudrun had dared them to join him calling Carrah at the dark of the moon. The brothers thought Gudrun jested, but Gudrun was apparently serious. He took his arms and armor and was last seen south of Backwater heading down the road into the Great Marsh.

Gudrun is thought a bit fey (particularly in his fascination with witchery and enchantments), but his father was loyal, even to his least son. Hakon sent Gudrun's four brothers out with a scolding, and with orders to find their little brother and bring him back home. Hakon scoffed at the common superstitions about the Witch-Queen, but his other four sons have failed to return after two weeks, and now Hakon is deeply frightened.

Hakon and his lord Ceowulf have publicly announced a 10,000 gold piece reward for the recovery of his sons, dead or alive, and privately they have appealed to the godar (priests) of Odin and Thor for champions who would seek out the missing sons.

**The Snowvale Valley:** Recent raids by kobold wolf-riders have prompted the local clanheads and the Castellan Town Council to hire specialists to track these raiders to their lairs, to exterminate them or hurt them sufficiently to discourage future raids. Two teams have already failed: one team failed even to track the riders, and the other team disappeared in the hills east of Snowvale.

The Snowvale leaders have now hired Vigfus the Red, a cruel and ill-reputed outlaw, to head up a group of kobold hunters. Ruthless and profane, Vigfus is nonetheless considered a gifted tracker and wilderness fighter. "I gets dogmen 'cause I thinks like dogmen," Vigfus explains. Critics add that he acts and smells like the dogmen, too. Vigfus is hiring adventurers for his kobold-hunting

expedition. He offers little coin up front. Instead, Vigfus contracts for substantial percentages of any spoils won.

Consequently, Vigfus entices mostly inexperienced or desperate adventurers into his service. Vigfus is little concerned. "Don't matter. Dogmen is wimps, one on one. Just gots to know dogmen, and nobody knows 'em like I knows 'em."

**Gnollheim Hills:** Men have often speculated on the source of the fine silver ornaments commonly worn by gnoll chieftains. Recently a group of adventurers returned from an expedition up the Angesan River into the Hardanger Range, where they found substantial deposits of silver. These adventurers have secretly approached Ragnar the Stout with their evidence, and have offered him a share of the workings of the deposits in return for funding a more substantial prospecting expedition, and for political protection of their corporation once mining has begun.

Unfortunately, one of the members of the original expedition is secretly a Loki cult member, and he has revealed the location of the site to his cult superior. This information has been passed on to the highest levels of the cult, where plans are being discussed for jumping the claim in order to enrich the cult. Three plans are currently under discussion:

- Infiltration of any Ragnar-supported expedition with Loki plants;
- Immediately dispatching a Loki expedition to the deposit, there to work the silver while waiting to ambush any later expedition; or
- Allowing a Ragnar-supported expedition to proceed to the deposits, shadowed by a Loki team who will wait until the Ragnar expedition has done its work. The cultists would then eliminate the group and steal the fruits of its labor.

Neither the Ragnar and Loki groups are well informed about the local dangers of the upper Angesan region— dangers which include monstrous wildlife, gnoll tribesmen, and kobolds whose tunnels reach into the vicinity of the silver deposits.



# NON-HUMAN RACES

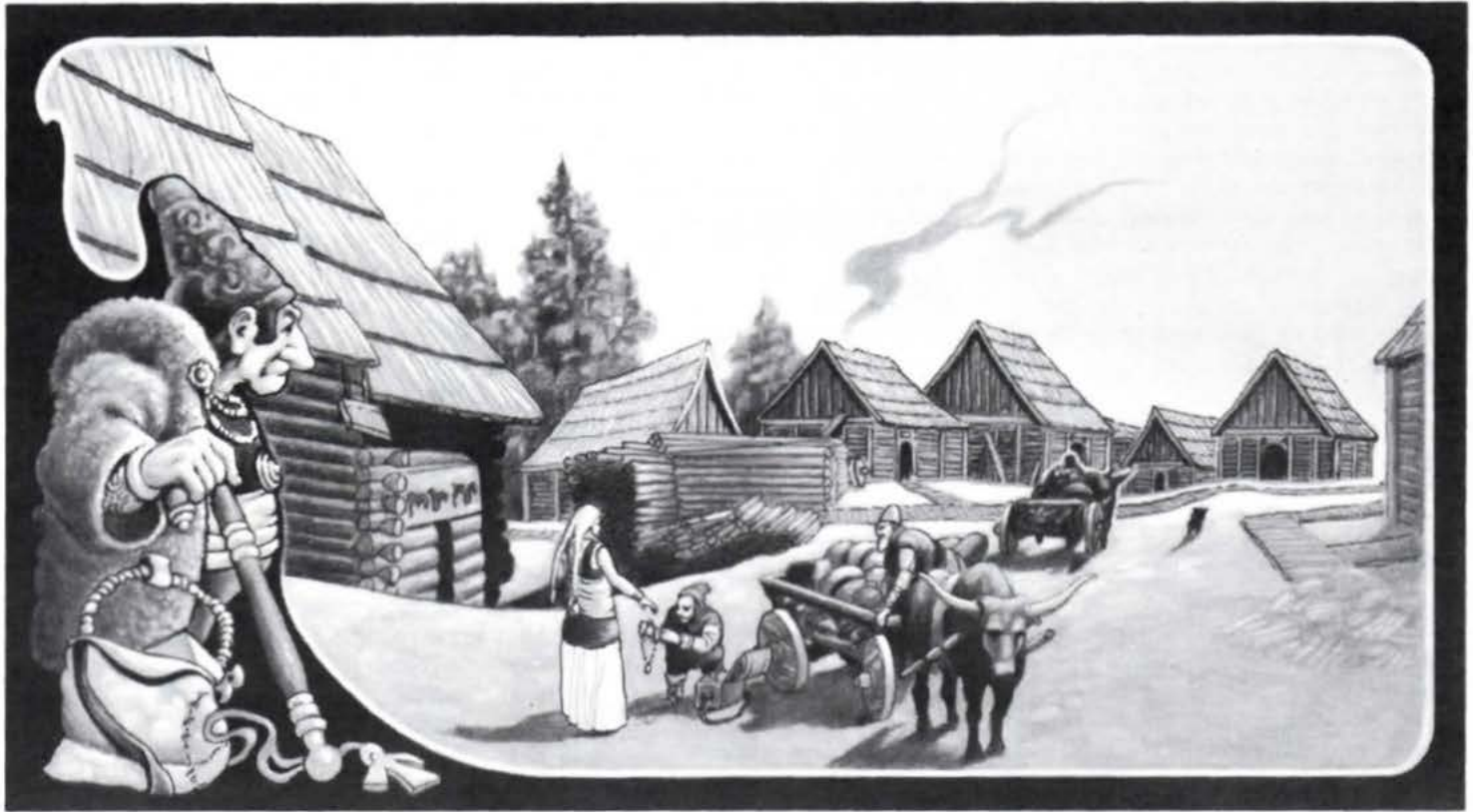

## Dwarves

"Dwarves? We got dwarves a-plenty here, all over the place. Nasty little beggars, but clever with metal and stone.

"Now, I've got no beef with most of them—they work and earn their bread like fate-fearing folk—but some of them are a rum lot. And when they've had a few too many, they can be real sensitive, and they've got few enough compunctions about splitting a man in half with those great axes they're so fond of.

"Mo-drig-whadja-say...? Oh. Rotten dwarves. Pfeh. Just kids' stories, like pixies and fairies. Live up in the mountains with the giants and make 'em magical spears that c'n crack mountains in half. Sure. A load of crap, if you ask me."

Olaf the Taverner

Dwarves are the most numerous of the non-human races in the Northern Reaches. They represent a substantial minority of the population—from one percent in rural and wilderness regions, up to five percent in larger settlements.

There is deep prejudice against dwarves in some parts of the Northern Reaches. In larger towns, dwarves often keep to their own communities—called the *gemeinschaft* by dwarves, the ghetto by Northlanders. In smaller communities, and in some city establishments, there are businesses which may refuse to serve dwarves. This is particularly true of taverns, where drunken dwarves often bring violence and destruction.

The most numerous and best known are the Rockhome emigres—emigrants or descendants of emigrants from Rockhome who have settled in the Northern Reaches as craftsmen, adventurers, vagrants, and ne'er-do-wells.

Less numerous and less well-known are the Modrigswerg—the rotten dwarves—a clan expelled from Rockhome centuries ago. The Modrigswerg settled in the remotest regions of the Makkres and Hardanger Ranges.

### The Rockhome Emigres

Rockhome dwarves proudly state that for

centuries their government has sent out dwarves to explore and settle the Known World. This statement is misleading. Only about ten percent of the dwarves who leave Rockhome are adventurers with funding. The majority are just ambitious young dwarves searching for excitement (adventurers), opportunity (young craftsmen) or they are outcasts, driven from Rockhome by law or social pressure.

**Adventurers:** There is no shortage of monsters, treasures, or perilous deeds to be done in Rockhome, but many dwarves seek adventure in the outside world. There they find opportunities to cooperate with other races, finding a particular interest in those races skilled in magical technologies.

A young dwarf remaining in Rockhome to seek adventure can expect to serve a long apprenticeship guided by older, wiser, and methodically cautious dwarven heroes. Given the great life expectancy of dwarves, and the strength of dwarven traditions and social conventions, the elder dwarves consider this to

## NON-HUMAN RACES

be only sensible. Only in the outside world among the Younger Races can a young dwarf be accepted as a peer in an adventuring or mercenary party.

Further, dwarven adolescence is a difficult and trying period for the young and for their elders, more so since dwarven adolescence lasts for several decades. During this period, the youngsters are called Troubled Youth. The young dwarves tend to be aggressive, violent, and resentful of authority. They resent the rigid clan structure, and are eager to see the world they've heard about. They dream of places a dwarf can make a lot of money bashing orcs and goblins, not wasting his life apprenticed to some old codger.

There is a tradition among dwarves that the Troubled Youth journey forth from their homes to learn common sense—and to blow off a little youthful energy. Thus the young dwarves are away from home during their most rebellious and destructive years, and are exhausted and grateful for the quiet and security of the clan hearth when they return from their adventures.

Originally the Troubled Youth went off to bother other dwarven communities. With the opening of the Known Worlds to dwarven travel, young dwarves now spend their adolescent years disrupting someone else's culture—a situation much to the elders' liking. The Troubled Youth (who more often refer to themselves as the Young Punks) also find this quite acceptable.

**Young Craftsmen:** Another important class of dwarven emigrant, the young craftsmen leave the rigid apprenticeship structures of dwarven culture to make their way in the human world, confident that their skills and fine workmanship will earn them good money. Indeed, dwarven crafts are much in demand throughout the world—dwarven jewelers, armorers, and artificers usually name their own prices. However, this easy money comes at a cost.

Many carefully guarded secrets are taught only to those who remain in the clan and apprenticeship structure. Though dwarven crafts in the Known

World are generally superior to those of other races and cultures, locally-made goods are usually inferior to the work of Rockhome dwarves. Thus, the finest dwarven crafts are Rockhome imports. Wealthy and powerful patrons recruit Rockhome craftsmen and engineers for important mining, tunneling, and construction, leaving others to hire local dwarven "experts."

**Outcasts:** Some dwarves never outgrow being Troubled Youths. Some are temperamental, intolerant of the smothering burden of dwarven tradition. Others are spoiled by wealthy families. As in all cultures, some become criminals through nature or circumstance.

In Rockhome, the sentence of Denunciation and Banishment is a common judgement for non-violent crimes, or for well-to-do offenders. Dwarves can conceive of no greater hardship than being physically and emotionally cut off from home, clan, and kin.

Convicted offenders are conducted under guard to a border and sent off with a kit roughly equivalent to that of a beginning D&D® character. Ethengar and Ylaruam are generally hostile to foreigners, but by contrast Vestland and Soderfjord are quite tolerant. Many of the banished leave Rockhome at the Vestland border along the Vestfjord or Landersfjord River gaps.

Finally, a dwarf may be expelled from his clan for societal reasons like lack of deference to elders, or refusal to marry as directed by the clanhead. Life in Rockhome as a clanless dwarf is very difficult. Other clans are reluctant to accept expelled dwarves. The Wyrwarf clan isn't very fussy, but it's a tough pill for proud dwarves to swallow. Many hit the road for the outside world, where loss of clan status is less stifling.

It is this class of emigrants that gives dwarves in the Northern Reaches a bad name. Some make their living by hiring out as temporary laborers or guards in mercantile districts or with caravans. Others make their living by less honest means, and a few manage to leech off the meagre charity to be had from the dwarven communities. Alcoholism is common

among the outcasts, and they have a reputation in the lower class urban districts for public drunkenness and violent crime.

### The Modrigswerg

The Modrigswerg are an ancient clan of dwarves exiled from Rockhome for pursuit of forbidden lore, and traffic with dark powers. Only the gnomes are their peers as artificers, but the Modrigswerg are said to be cursed by the Darkness, condemned forever to suffer distrust, treachery, and madness.

### History

Onund Tolundmire: *"I doubt whether the history of the Modrigswerg is known in detail to any but the Immortals or to the eldest dwarven loremasters. This story I've pieced together from legends and rumors, and even Dwalinn can't add much.*

*"Centuries ago, a small Rockhome clan called the Modrigswerg conspired with dark elves, and with priests of the Father of Demons—this last, an obscure cult worshipping Immortals of the Sphere of Entropy, and identified with various modern dark cults, depending on who you talk to. This conspiracy sought to bind the powers of life and magic into devices which might be used to conquer and rule the world. A common enough fantasy, but within the grasp of such a foul alliance.*

*"The dark elves brought the secrets of life and its rulership. The Father of Demons cultists brought the rituals of summoning and binding otherworldly powers. And the dwarves brought knowledge of metalworking and mechanisms.*

*"Accounts of the league's failure differ. In some, the Immortals interfered. In some, dwarven heroes stormed the league's citadel and slew the leaders. In some, the confederation destroyed itself with treachery and betrayal.*

*"The fates of the dark elves and the cultists do not concern us here. The Modrigswerg were judged by the other dwarven clans to be tainted with evil. The*

Modrigswerg elders were executed for their crimes, and the entire clan was Denounced and Banished, the name of the clan to be struck forever from the annals of dwarvenkind. It was then that the Modrigswerg came to be called the 'rotten', or 'moulder' dwarves.

"No legends tell of the exodus of this clan banished from Rockhome. We know from giantish tales that the exiles eventually moved into caverns and tunnels deep beneath the wildest lands of the Makkres and Hardanger Ranges.

"Then the Modrigswerg were cursed of the Darkness. Tales of the cursing vary enormously, but the behaviors brought on by the Curse are well established.

"First, the rotten dwarves became utterly solitary and anti-social. Most live alone or in tiny family groups, with great distances separating households. Even family members rarely communicate with one another. Outsiders, whether dwarves of other clans or humans, are unwelcome; they are avoided if possible, ambushed and slain if convenient.

"Second, the Modrigswerg are plagued by fits of madness and irrationality. They are all treacherous and unpredictable. Whether this is the fault of the Curse, a side-effect of their social isolation, or a result of trafficking with dark powers is a matter of conjecture."

Dwalinn: "Look. This 'curse' business don't enter into it. You sit around alone in the dark eating slugs and mushrooms for a couple of centuries, and see if you ain't just the picture of mental health!"

### Way of Life

Much of the information about the rot dwarves is given here in theoretical terms. The purpose is to let DMs develop their own aura of mystery around these strange beings. What possibilities aren't actually used can be given to PCs as rumors and red herrings.

**Contact with Outsiders:** Because of their unpredictability and their hostility toward visitors, the Modrigswerg are approached by very few. The giantish races deal with them for arcane devices, and powerful wizards seek them out as

engineers and craftsmen for towers and dungeons. Bold entrepreneurs deliver cargoes of provisions at remote mountain meetings, where they are paid in gold and gems. Adventurers seek out the Modrigswerg to steal their treasure, or to purchase the artifacts the rot dwarves hoard in their hidden tunnels.

**The Wealth of the Moulder Dwarves:** The Modrigswerg are artists, skilled workers in silver and gold which they mine deep beneath their subterranean dwellings. They work skillfully-cut precious stones, particularly diamonds and rubies, into their jewelries and devices. These gems are also taken from their own mines, or are brought by giants and Immortals as payment for work done, or as raw materials for a desired project.

As valuable as these raw materials may be, they are of less interest than the fabulous and bizarre artifacts the Modrigswerg create in their cavern workshops. Even the Immortals prize their workmanship, most particularly Immortals from the Sphere of Entropy, who generally have little gift for craft or enchantment but an endless appetite for devices of command and destruction.

The Modrigswerg made the spear *Gunghir* for Odin, the spear which never misses. They made *Skipblade*, Frey's enchanted ship which always finds a favorable wind, and which folds like a handkerchief to be placed in a pocket. They also crafted for Frey a golden boar, whose bristles sparkle to provide light, upon which Frey may ride over sea and air, day or night. Thor's famous hammer *Mjollnir*, that always strikes, destroys, and returns to his hand, is of Modrigswerg craftsmanship. Thor's wife Sif is said to wear golden hair crafted by the Modrigswerg, a gift given in recompense for a prank by Loki the Trickster.

Mortal followers of these Northland Immortals may be loaned these magnificent devices when engaged in a great quest. Thus, these devices may play a part in the adventures of many Northland heroes.

The Modrigswerg also deal with less exalted customers. Great sorcerers and heroes, particularly those questing on the

Path of Immortality, come to the Modrigswerg to purchase arcane items made with skill and subtle cunning. The moulder dwarves charge extravagantly for their services. For example, a *warhammer +5 of flying*, available in Glantri for 25,000 gold coin, could cost 35,000 gold or more. They refuse all but the most challenging and unique projects. ("A ring of protection? Pfeh. Anybody can do one of those...") They charge high prices in part because they refuse to work with anything but the finest materials, provided from their own inventory, or required from the purchaser as a condition of accepting the project.

The Modrigswerg are also masters of the engineering specialty of dungeon trapping. Again, the Modrigswerg consider themselves artists, not exterminators, and always prefer bizarre, complicated, and expensive designs over the simple, efficient, and practical. Even when a pit trap would do, the rot dwarves install sliding walls, counterweights, hair-triggers, false doors, and spring-loaded gimcracks. Dungeon traps of illogical but elegant complexity are usually of Modrigswerg design. Only the wealthiest of evil wizards and dark lords can afford the moulder dwarves' services. The reclusive Modrigswerg hate to travel, and charge even more exorbitantly than usual for house calls.

Dwalinn the Dwarf: "I don't want to count how many times I've found myself dangling by one ankle from a wire loop, sliding down a track toward some glittering mechanical marvel. And too many times I've heard a partner say, 'Hey, Dwalinn—Modrigswerg work!'"

**Lifestyle:** Like all dwarves, the Modrigswerg are extremely traditional and conservative. There is a right way to do things—their way—and no other way is acceptable. Since the Modrigswerg have been isolated from the mainstream of dwarven culture, their language and customs will seem archaic to modern dwarves. For example, few Modrigswerg speak Common, or any tongue but an archaic form of Dwarvish. They also

## NON-HUMAN RACES



speaking dialects of Gnomish, Goblin, and Kobold; those who deal with the Hardanger kobolds may be somewhat fluent in Kobold.

**DM Tip:** Speaking old-fashioned English, something quasi-Shakespearean with thee's and thou's, can suggest the old-fashioned dwarven dialect and improve the flavor of the game.

Other dwarven traits and traditions remain common among the Modrigswerg. Most wear colorful garments, and consume vast quantities of

indifferently prepared food. They proudly hang their ornamental weapons, armor, and heirlooms; homes have fine stonework and engravings. The rot dwarves are fiercely protective of personal property, greedy for gems, jewelry, and mineral wealth—all for their own satisfaction since visitors are such a rarity.

The Modrigswerg honor dwarven traditions in queer and eccentric ways. For example, the rock engravings and runescritps decorating the tunnels of one Modrigswerg individual are exceptionally

detailed and fantastic, full of distinctly un-dwarflike curves and flourishes. Another Modrigswerg always wears every bit of jewelry he owns: dozens of pendants, silver and gold wrist bands, and rings on every finger joint. Nonetheless, no matter how bizarre or insane, most Modrigswerg behavior can be interpreted as an exaggeration or perversion of an honored dwarven tradition.

Like most dwarves, rot dwarves are not picky eaters. Most of their food is purchased in great quantities from non-human races or from trusted human allies who have proved able to keep a secret. The rot dwarves have adapted to infrequent food supplies primarily through the technology of processed food being put by. Various foodstuffs are boiled together in great vats, forming a sort of stew, which is then sealed in metal canisters. Such "canned" food is said to be nourishing, but tasteless.

Rot dwarves have also borrowed from the kobolds the practice of cultivating molds and mushrooms underground, and maintaining herds of semi-domesticated cavern creatures for fresh meat. Some Modrigswerg freeze foods, employing arcane refrigeration technologies. Some purchase magical food-providing devices from enchanters.

The world knows little of the personal lives of the Modrigswerg. They dislike meeting their clients in person, whether giants, wizards, or adventurers. They prefer to work through agents or through messages carved in Auld Dwarf runes on rock slabs. When the rare meeting is arranged, it is always in a secure place remote from the dwarf's home—in an unused cavern, or on a remote peak.

Modrigswerg are, by their own assessment, obsessive workers. They make no distinction between work-for-hire, hobbies, and play, throwing themselves into every project with the same obsessive, uncritical enthusiasm. As with all the Elder Races, they need little sleep and are capable of working for days without a break.

The Modrigswerg suffer periods of extreme depression, often accompanied by alcoholism and self-destructive behav-

ior. Legend links this to the Curse; most dwarves feel it is a natural consequence of the moulder dwarves' perverse isolation from family and kin.

Like other dwarves, the Modrigswerg set great store by memorization of family trees and oral clan histories, but they are extremely reluctant to reveal them to outsiders. Those experienced in dealing with the moulder dwarves say they earned limited trust and respect from the Modrigswerg by being knowledgeable about their own family trees and about the ancient history and culture of the dwarves. Those with poor memories earned the dwarves' contempt.

The Modrigswerg are exceptionally long-lived, even for dwarves, although suicide accounts for many deaths among these mad dwarves. Historical records show that some individuals are at least four hundred years old, and certain dwarves speak of events over six centuries past as though they had been eyewitnesses. Still, reports of immature dwarves are rare. Tales link their infertility to the Curse, but it may simply be Modrigswerg selfishness and an obsession with privacy.

**Worship of the Immortals:** The moulder dwarves evidently follow the dwarven tradition that clerics do not reveal themselves to outsiders, if indeed they have clerics at all. The Modrigswerg do not venerate Kagyar the Artificer, Denwarf Dwarffather, or any other traditional Immortals or heroes.

There is only conjecture as to which Immortals the Modrigswerg now serve, if any. Legends say that the Modrigswerg were cast out of Rockhome for worshipping the Father of Demons; it may be supposed that some still maintain this cult, or a similar one. Another consideration is that the Modrigswerg are known to deal with the Lords of Entropy. Though one need not worship the Entropic Immortals to deal with them, knowledge of their rituals is necessary for safety, and oaths of loyalty are commonly demanded for the services these beings render. (DMs should pick what best fits their own campaigns.)

### Trades, Crafts, and Sciences —

In general, the Modrigswerg have maintained the same skills and lore they had when they were banished. They are adept in metalsmithing, gold- and silversmithing, armoring, weapon-making, gemcraft, sculpting, engraving, engineering, mining, geology, metallurgy, and other disciplines usually associated with dwarves. Their practices are, if anything, archaic and out-of-date. Some cave-dwelling practices of the kobolds have been adapted to dwarven use. The rot dwarves also occasionally receive ancient gnomish artifacts from trade with the kobolds, and thereby are introduced to novel applications of known principles. Otherwise, the Modrigswerg are not noted for their ingenuity or originality.

*"A dwarf never had an original idea. As Anlaf the Poet says:*

*'Dwarves are stone-headed:*

*'Strong thoughts, but old as the hills,*

*'As light, witty, and frolicksome.'*

*"Gnomes, now, they're the ones to get crazy ideas. Not dwarves. What's new and ingenious, and made by dwarves, comes from the giants and wizards who hire them. Plenty of bad ideas there, and rot dwarves all too eager to bring them to life for a generous sum."*

Saru the Serpent

**Craftmagic:** Notwithstanding their lack of originality, the Modrigswerg have mastered two disciplines not practiced by any other dwarven culture—the life-bindings of the dark elves, and the artificers' crafts associated with the Lords of Entropy. These two disciplines, combined with conventional dwarven skills, enable the Modrigswerg to create unique devices.

**Dark Elven Life-Binding Rituals:** These rituals involve the sacrifice of a living creature in order to bind some element of its essence into an inanimate object or another living being. When applied to an enchanted object, the life essence confers upon its user a power or special ability associated with the being sacrificed to create it. When applied to

another living creature, the life essence may produce the effect commonly known as shapeshifting, or may confer the senses and abilities of the creature sacrificed.

*"Obviously you wouldn't call this 'white' or 'good' magic. Not many would object to killing a couple of chickens to enchant a sword, but then, who would want a sword with the abilities of a chicken?"*

*"Three principles make these magical practices most objectionable. The more intelligent and powerful the creature sacrificed, the more valuable the artifact. And, the greater the quantity of life sacrificed, the more powerful."*

*"Finally, larger artifacts require a greater volume of life—a principle most distressing, since giants are the primary customers for such creations!"*

Saru the Serpent

**The Artificers' Crafts:** Conjunction spells, like *conjure elemental* and *invisible stalker*, imply transportation of a being from another plane of existence, generally for a limited time, and against the wishes of the being summoned. Craftmagics, on the other hand, involve bargaining with or purchasing a period of service from the conjured being, with the terms of service and payment determined in advance. The conjured being enters into the agreement voluntarily (except at the highest level of craft proficiency), and therefore must be convinced that the experience will be profitable or "fun" in some sense.

Other-planar beings with short lifespans are unwilling to offer substantial periods of service, making the expense, difficulty, and risk involved with conjunctions senseless. Outer Plane beings like elementals, efreet, and djinn are sometimes willing to bargain for long service, and the Lords of Entropy may bargain for the service of their minions, who have little say in the matter.

**DM Note:** Life-binding rituals are strictly NPC magical abilities, generally associated with evil villains. PCs won't get access to these abilities except through magical items, and even then PCs should regard them as "cursed" and evil, rather than useful treasures.

## NON-HUMAN RACES

A DM should remember, however, that the fantasy tradition is full of good heroes and heroines carrying tainted, powerful magical devices. They possess these only to keep them away from the bad guys, or to use in desperate circumstances where evil must be fought with evil. (Frodo with the One Ring, Morgaine with Changeling, and Elric with Stormbringer are three literary examples that come to mind.) Characters bear these items reluctantly, and use them only at direst need, fearful of the consequences of the use of these evil devices. The items described below can be used—judiciously!—if play balance is kept on an even keel.

### Examples of the Modrigswerg's Craft

**Micro-Golems:** These devices are extraordinarily expensive, requiring thousands of miniature parts hand-crafted from rare alloys and fitted with patient, painstaking care. Golems follow their owner's orders, and are often used by sorcerers and alchemists as an extra pair of hands for close work. Others have been purchased as intelligent operators of complex traps and security systems.

**The Ring of the Nine Svartalven:** This ring was crafted by the masters Brokk and Sindri as a wedding gift for a Great Giant's wife. The ring is three feet in diameter, solid gold, decorated with gems and enameling. Into the ring are bound the life-forces of nine dark elf sages.

The ring is fashioned to resemble a dark elf grasping his toes in his outstretched hands, bent backwards into a ring. When summoned by name, the spirit of a summoned dark elf responds as the gold forms into a likeness of his face. The eyes and mouth of the golden face move as if alive, but the rest of the dark elf figure remains solidly formed as a ring.

The nine dark elf sages are each masters of a specific arcane discipline:

- Harmacar*—the lore of intelligent swords
- Angalomē*—sorcerous metalcraft

- Vanistar*—lost magical arts
- Eldalomē*—dark elven royal histories
- Menelo*—planar travel
- Sindaya*—the lesser Immortals of the Sphere of Entropy
- Lossemir*—cold-based spells and enchantments
- Mornanor*—necromantic spells and enchantments
- Fesar*—life-binding rituals

The ring was given to the giant's wife in the hopes that she would develop an interest in these disciplines. The wife was unimpressed, and the ring lay forgotten among her other gifts, until it was stolen by an adventurous thief.

The ring is now in the possession of King Hord Dark-Eye of Ostland, who has had it made into a table which he keeps in his treasury with numerous other oddities. Neither the original thief nor King Hord have any notion of the ring's function, save that it is magical. The ring is useless without the names of the spirits bound into the ring, even if its function became known. Only the giant and his wife, and Brokk and Sindri who made the ring, know those names.

**DM Note:** A device of such power and evil is most appropriate as the focus of a campaign quest or as the subject of a quest on the Path to Immortality. It is also an example of the cheerful indifference of Modrigswerg craftsmen to the hideous processes involved in the manufacture of their items, since nine dark elves had to be sacrificed to create this artifact.

**The Spear of Giant-Slaying:** When thrown, these three-foot javelins grow to twenty feet in length, and unerringly strike for the eye of a giant.

Most Modrigswerg boast of owning one or two of these devices, but in fact there are relatively few of them in existence, and most are owned by the Immortals of the Northlands pantheon. Modrigswerg assert ownership of these spears largely as a deterrent against treachery by giant clients. But moulder dwarves will also cheerfully sell bogus Spears of Giant Slaying at fabulous prices (but what a discount!) to naive adventurers.

**The Barnyard Puzzle Maze:** This elaborate trap/puzzle/security system was designed for an eccentric Immortal of the Sphere of Energy as a test for those on a hero quest. The maze is a sequence of passages and physical puzzles that can only be negotiated through the clever use of shapeshifting magical devices scattered throughout the maze. These devices permit questors to transform themselves into a variety of small common creatures like chickens, frogs, fish, hummingbirds, and snakes. Each problem the maze presents can be solved through the use of the peculiar talents of a different animal species. The object of the maze system is to find the magical device which can transform the questors back into their original forms and thereby exit the maze.

The physical location of this maze is in a small outer plane. Access is usually by invitation from the Immortal. However, the dwarves also created a permanent gate disguised as a treasure chest—a chest which DMs can put in a dungeon hallway, lying where a previous party of adventurers opened it. Encounters with these unsuccessful puzzle-solvers can be an amusing embellishment on the maze's original design.

**DM Note:** A final word about these artifacts. Inexperienced or power-crazed gamers may be more fascinated with the powers of such devices than the negative effects of their evil nature. Ideally, your gaming group will not fall into this trap, but if you anticipate this sort of response, be prepared to remove these artifacts from the campaign. Here are two ways to take gross, evil magical devices from trigger-happy PC heroes.

- A bigger bad guy comes along and takes the devices from the PC. If Frodo had gotten too carefree using the Ring, Sauron would have found him in a jiffy; that would have been the end of Frodo.
- The devices themselves may seek a more appropriate owner. Intelligent items have a way of betraying their owners when the prospect of a better master appears. "Oh, no, master, no danger down here. No sirree. But boy, do I detect treasure!"

## The Trolls

Almost nothing is known about the history of trolls in the Northern Reaches. Under aggressive questioning, troll prisoners reveal nothing—the fact is, they show no concept of history whatsoever.

Giants arriving in the Northern Reaches around 1600 BC found the trolls already present, and they were not impressed. Recorded human contacts with trolls date back to the third century BC, when primitive barbarian tribes wandered into the Trollheim hills and were eaten. Subsequent contacts have scarcely been more rewarding.

**Culture:** Despite their legendary hankering for human flesh, trolls actually eat anything. Apparently rocks and metals take longer to digest than organic foods, and they are not pleasing to the troll palate. Plant matter, whether vegetables or tree stumps, is acceptable. But for a quick treat, trolls relish human flesh. This adaptable diet permits trolls to live anywhere, above or below ground.

Troll wounds and injuries heal at a remarkable rate. This regenerative ability makes playful activity peculiarly aggressive by human standards. Troll youngsters think nothing of popping the arms or legs off their playmates, and the victims show no ill-will for such mistreatment, as the effects don't last.

As a result, trolls appear virtually fearless to humans. Although trolls do feel pain, it only makes them uncomfortable rather than terrifying them. Trolls who have experienced fire or acid may display an intense fear of these phenomena because they cause injuries that do not heal. Trolls do not seem to fear magic, other than fire magic, apparently because they are too dim-witted to understand its effects.

Trolls are powerful, fierce, but unimaginative fighters. They are barely conversant with the notion of tools, but they do learn to use improvised weapons like tossed rocks and tree-limb clubs in their various games and sports.

Because of their remarkable durability and even more remarkable stupidity, trolls are fond of exceptionally simple,

macho-type sports and games—anything that exercises their bone and muscle without making demands on their brains.

Take tree-ramming, for example. Trolls run head-first into trees, over and over again, until the trolls or the trees fall over. Sometimes the object is to be the last troll to fall over, sometimes the object is to knock over the tree. Since the trolls generally forget the object of the game long before the tree or a troll falls over, the game quickly degenerates into mindless confusion, with laughing trolls running full-bore into anything that holds still long enough to be hit. Other games, like Cliff Diving, Toss-the-Tiger, and Chicken-Kick, are equally pointless and violent, and no one but a troll would care to be involved.

**Recent Developments in Trollheim:** As recent military campaigns into Trollheim continue, the youngest generation of trolls is becoming wary of Man, and more cautious and resourceful in confronting human adversaries. Some trolls have been reported using a variety of weapons in imitation of human usage. Others are showing courage and ingenuity in coping with fire attacks. Experts worry that the military efforts may inadvertently produce an aggressive, thinking breed of troll—clearly a greater threat to Northland culture than the less sophisticated trolls normally found.

**Relations with Immortals:** Trolls have no idea what an Immortal might be, or what worship is. Facing an Immortal visitor, a troll would probably try to eat him.

**Relation to Other Humanoid Races:** All other humanoid races are a source of nourishment. Giants are an exceptionally *dangerous* form of nourishment.

**Relations with Humans:** Humans are a prized source of nourishment. Humans like fire, which trolls definitely don't like. If given a choice between a human carrying fire and a human carrying no fire, trolls always attack the human without fire. Trolls do not connect the phenomenon of light with fire, and are not intimidated by magical light.

**Crafts and Technology:** The only thing a troll knows how to make is noise. Trolls have been known to use weapons and



## NON-HUMAN RACES

shields, but not necessarily in the way the items were intended to be used. (Some of the variations are surprising.)

Trolls have very limited attention spans, and they can lose and rediscover an object held in their paws many times in the space of a few minutes. As a result, although trolls absentmindedly collect items in their lairs, they are totally indiscriminate in what they collect.

A troll will have no idea what you mean when you ask where his treasure is. Adventurers seeking treasure in a troll's lair find it is mostly a matter of luck, since trolls do not have any of humanity's concepts of value.

**Magic:** A troll's regeneration and other abilities are natural, not magical. Trolls do not understand magic, and neither fear nor value it. Magic users are simply humans without the annoying metal husks.

### Noted Troll Personalities

**Two-Ox Charlie:** Two-Ox Charlie is a tame troll owned by Hord Dark-Eye, High King of Ostland. Charlie is often in attendance at social functions, serving the king's dinner—a table covered with food, casually flourished one-handed. He entertains guests with tricks and mock combats. Charlie speaks passable Common, recites poetry, and reportedly is better at arithmetic than the king. He dotes on Yrsa, who tolerates him. When asked why he puts up with civilization and servitude, Charlie observes that he eats better here than he would in Trollheim, and that humans know more interesting games than trolls. The king has repeatedly denied that Charlie is fed on human thralls.

### The Hill Gnolls

Gnolls were the first humanoid race to settle in the Northern Reaches after the ice caps retreated. Nomadic gnoll clans are widely dispersed in rugged regions throughout the Known World.

Gnolls are less formidable than orcs or kobolds, militarily. On their own ground, however, they are shrewd and stubborn

adversaries, as the border garrisons at the Sodervirk can testify.

**Culture:** Gnolls are nomadic herders of mountain sheep, and warlike predators upon other races. The culture is cruel and violent and, failing to find another foe, gnolls will fight among themselves. Ruthlessness and skill in battle are the dominant racial traits. Social order is determined by force; the biggest and toughest have everything.

Gnolls seldom cooperate in groups larger than their immediate clan. Even in such small groups, fights break out over choice of leader or tactics, division of spoils, or any other point of debate.

Tribal warfare is unending. In battle, gnolls prefer taking captives, who then become slaves of the victor, but no quarter is offered or given. Intertribal battles are brief, often indecisive, with both sides withdrawing when adrenaline runs low or when quarrels disrupt the groups.

The gnoll's powerful frame, sure-footedness, and hardy conditioning give him a movement advantage in rough terrain. (Gnolls move at cavalry speed in mountainous areas.) Individually, gnolls are as powerful as trolls, but more numerous and better organized—more than a match for humans in rough terrain. They have no interest in the underground, so they cheerfully ally with kobolds when common objectives permit. With assistance from kobold advisors in the Grollheim region, a few gnoll clans are becoming increasingly effective in their use of military tactics. These clans are also reported to use superior, dwarven-style weapons and armor obtained from the kobolds.

**Relation to Other Humanoid Races:** Less resistant to cold than giants, gnolls avoid high elevations except during the summer. During that season, hill and stone giants raid their herds to steal sheep, and the gnolls enjoy the challenge of protecting their flocks.

The kobolds of the Hardanger Range have established close relations with a number of Grollheim clans. Normally neutral or hostile, the gnolls and kobolds are brought together by their common hatred of the human settlers colonizing

the hill country. The contentious nature of both races makes this a fragile alliance, but nevertheless an extremely dangerous one.

**Relations with Humans:** Humans are considered dangerous but exciting prey. Gnolls have a healthy respect for human magic, and a taste for human flesh. Gnolls do not trust humans, but they will trade with humans to obtain quality weapons, armor, magical items, and alcohol, for which local gnolls have developed a thirst. Sorcery and bribery may enable humans to obtain gnoll cooperation, if raiding and looting are part of the reward.

**Worship of the Immortals:** Northern Reaches gnoll clans worship the Lords of Entropy. Many clans worship a specific demon; for example, the Double-Rock River Clan worships Ranivorus, a Howling Demon. (See *D&D® Immortals DM Guide*, pp. 30-32 for demon descriptions.)

As with all Immortals, demons are enjoined by Immortal law from interfering with events on the Prime Plane. However, the Immortals of Entropy are less scrupulous in their interpretation of what constitutes "interference." Demonic artifacts have been provided to some gnoll followers, and occasionally a demon may involve himself in gnoll affairs, using a disguise or magical abilities to conceal his presence from observers.

Although shamans among the gnolls are generally regarded as weaklings and misfits, they have much influence behind the scenes in clan politics. A chief must have the support of the shamans or he cannot command his tribe.

**Crafts and Technology:** Gnoll goods are primitive. Warriors wear poorly-made leather armor, and use crude shields, spears, clubs, bows, slings, and other simple weapons. Gnolls may also use plundered weapons and armor, or modern arms purchased from unscrupulous traders. Warlords and wizards elsewhere have managed to outfit, train, and field allied gnoll armies. As yet, this has not occurred in the Northern Reaches.

**Magic:** Grollheim gnolls do not have wiccans, and may fear magic users and



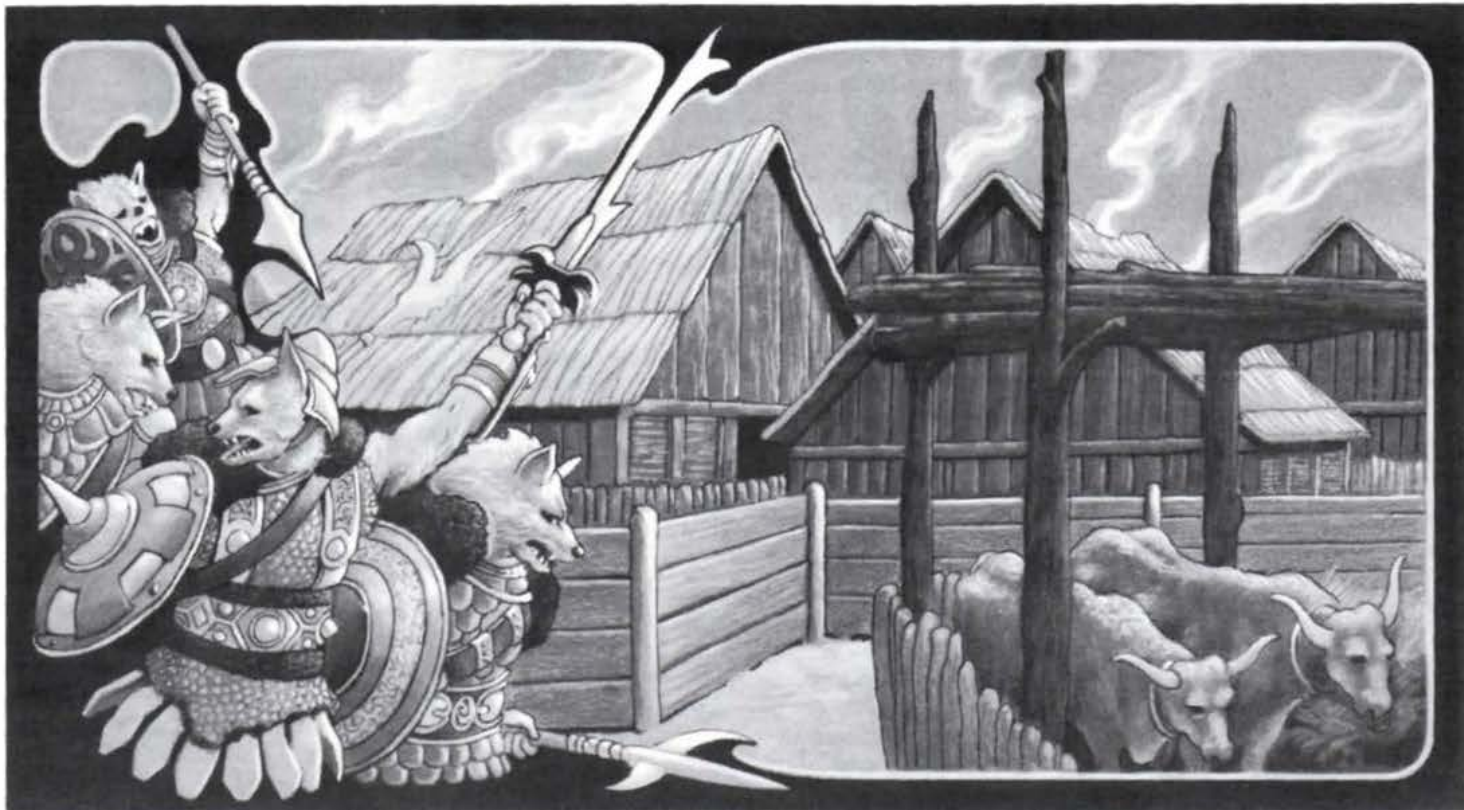

their spells. Gnolls rely on their tribal shamans for healing and other clerical spells. Minor shamans (Levels 1-2) are numerous; most raiding parties will be accompanied by one or two such.

#### **Noted Groll Personalities** —

**Kaberu, chief of the Mountain Wolf Clan:** Kaberu's reputation has grown to legendary stature in the Whiteheart region. His raiding parties strike swiftly into the lowlands north of Whiteheart, ambushing trade caravans and river traders along the Otofjord River and plundering settlements throughout the Otofjord Valley. The border garrisons are baffled by his ability to pass the Sodervirk wall without detection, and to evade the far-ranging border patrols sent into the hills in pursuit of Kaberu's war bands. Rumors say that Kaberu has either sorcerous or Immortal aid. Captured gnoll weapons and armor of Thyatian make suggest foreign support, but Thyatian representatives stoutly deny any contact with the clans.

**Suant, chief of the Black Cliffs Clan:** The large Black Cliffs Clan lives in the Angesan Valley in the foothills of the Hardanger Ranges. Untroubled by human colonists or smaller gnoll tribes, the Black Cliffs Clan is relatively peaceful under the guidance of the elderly Suant.

However, young gnoll warriors have challenged Suant's leadership, claiming that he has denied aid to the warlike northern gnoll clans who resist the intrusion of the humans.

These younger warriors, under the leadership of Chela, a charismatic gnoll war leader, have secretly allied with the kobolds of the Hardanger Range. For promises of magical and technological treasures plundered from the caverns of the gnomes, Chela and his followers have sworn to bring the Black Cliffs Clan into the war against the human settlers.

# The Court of Cnute

The Court of Cnute at Ostland is quite detailed, a framework for a Northern Reaches campaign, although shorter adventures are perfectly reasonable. Important background information about the nation of Ostland begins on page 10.

The first part of this section describes the important people, and major events occurring. The second section maps the important locations in the area. Following that are techniques the DM can use to run a full-length campaign.

Most natives of Ostland consider the Royal Court at Zeaburg to be the highest flowering of civilization in the Northern Reaches. (In their view, Vestlanders have fallen away from the Northland ideals, corrupted by the decadent cultures of the south.) Adventurers who have traveled more widely through the D&D® Game Known World may find the Royal Court's self-asserted superiority less convincing.

Ostland's strong centralized government has its heart inside the Royal Compound in the somewhat barbaric "metropolis" of Zeaburg (actually a scatter of residences surrounding the Royal Compound and the Lower Fort). King Hord Dark-Eye rules with ruthless strength, his word enforced by a large standing army and the loyal support of the war-like jarls and nobles of the lesser Ostland clans. Twenty handpicked noble guards form his honor guard—fierce, fanatic warriors renowned throughout the Northern Reaches. Collectively, they are known as the Brothers of the King.

Others in the kingdom wield power of their own in a delicate balance of political intrigue and diplomacy. The priesthood of Odin, led by the guileful Asgrim the Bowed, exerts wide influence and seeks to expand its power. But perhaps the most underrated figure of diplomatic importance is Hord Dark-Eye's mate, Queen Yrsa the Young. Her political acumen is matched only by the intensity of her resolution to drag her backward realm into the mainstream of the civilized world.

## Personalities

### King Hord Dark-Eye

*High King of Ostland (F28, St 15, In 12, Wi 11, Dx 15, Co 18, Ch 17, AL Neutral)*  
*Traits: Modest 8, Peaceful 5.*

King Hord Dark-Eye exhibits the manly virtues of a warrior people to his subjects' loyal and enthusiastic approval. Through the last twenty years, he has ruled the islands with a strength his predecessors on the throne have not matched since the rise of King Cnute himself. Hord is a man motivated by power, control, and a real delight in a good fight. Sadly, he lacks a guiding vision of public welfare and prudent governance that would have made him a truly great warrior-king.

At 51, King Hord no longer swings a battleax with the vigor of his youth. Instead he encourages the belligerence of those around him. He fosters the petty quarrels of the Ravenguard against the Brothers, and delights in their competition. The rambunctious warriors respond with untempered loyalty and constant one-upmanship.

King Hord's tastes grow bloodier year by year. Where once he was content to watch a lynx torment a field mouse for entertainment, now he talks of condemning criminals to face captured monsters like his tame troll, Two-Ox Charlie.

Hord has long since wearied of the petty details of rule, and he envies the young fighters their simple, violent solutions to their problems—even though experience has taught him that thoughtless violence is no lasting solution. He is impatient with the wearisome chores of understanding and guiding affairs of state. He'll lend an ear to outrageous schemes to enrich his treasury rather than pay attention to a tedious advisor droning on about some serious border dispute that needs settling. His growing indifference leaves a power vacuum, being filled by others.

The early death of Hord's first wife, Rhora Anlafsdottir, was the first blow to Hord's love of rulership. Hord and Rhora were perfectly traditional Cnute clan monarchs (the royal house of Cnute

being a clan within the Zeaburg clan). Hord hoped their union would produce a son strong enough to ascend the throne after him, but Rhora died childless. Hord remarried, holding the same hope for strong sons. Although he has fostered some promising young nobles into his household, he refuses to name any one of them his heir. The succession to the throne is therefore in question, although Queen Yrsa would have the strongest claim by tradition.

**DM Note:** King Hord maintains all the trappings of power. Most of his subjects and many knowledgeable foreigners still consider him the ruthless, absolute ruler of Ostland, even though others are shaping the counsels and policies that guide the nation. Those seeking aid in Zeaburg must maintain the appearance of acknowledging and honoring King Hord's authority, even as they court effective help from other influential figures behind the throne.

### Asgrim the Bowed

*High Priest of Odin (C21, St 11, In 15, Wi 17, Dx 9, Co 12, Ch 15, AL Lawful)*  
*Traits: Cautious 14, Reverent 16, Forgiving 3, Trusting 4, Dogmatic 18. Knows as, algr, and tiwar runes. Owns several rune-inscribed objects.*

Asgrim is a very ambitious man with the vision the king lacks. A decade younger than Hord, Asgrim became the king's associate relatively early in his rule. He is young for his position, but he has many factors working in his favor. He is discreet, his ambitiousness is carefully channeled, and he has the god's favor, which has raised him through the ranks swiftly. He represents the hard-core traditionalists who feel that the old Northman ways are the best, with every member of the society knowing his place.

For the last ten years, Asgrim has been King Hord's closest advisor. Traditional Northman kings lead their warriors in the field, and so King Hord has spent many seasons away at war. When he was away, Asgrim ruled in day to day matters. Under Asgrim's guardianship, the power of the priest class grew tremendously as the head priest utilized his connections to

stay informed and to dispense swift justice to all parts of Ostland. King Hord expanded on this framework whenever he returned to the throne.

The diplomatic policies of the Odin cult in combination with the ruthless application of Hord's military authority make for a united nation ruled very efficiently. The society exhibits the worst and the best things provided by sound central rule: social classes are utterly rigid, individual expression and innovation are repressed, and honest commerce is difficult and limited; but crime is rare, laws are consistent and reliable (if harsh), and a degree of peace reigns within the borders.

Asgrim's nickname derives from his crippled back and from the obeiances he gives the king—some say to excess. Asgrim disclaims all personal ambition, acting "for the good of the nation," or simply "on his god's orders." However, he is dogmatic, tradition-bound, and rather xenophobic. The world he envisions would be narrow, bleak, and unforgiving, an oligarchic theocracy, with Asgrim himself on the throne of Ostland.

**DM Note:** Asgrim wields tremendous power but entirely behind the scenes. He is a Richelieu who manipulates others adeptly but who will not take actions that will expose his hand. His subtle manner and air of subterfuge draw some suspicion among a forthright people. He is more feared than admired, particularly among the nobles and leaders of King Hord's household who can glimpse his machinations at royal audiences and councils.

### Queen Yrsa the Young

*Also becoming known as Yrsa Deep-Minded. (C8, St 13, In 16, Wi 18, Dx 11, Co 10, Ch 17, AL Neutral) Traits: Cautious 15, Peaceful 12, Courageous 14, Energetic 15, Dogmatic 5. Knows man-rune and owns several rune-inscribed objects.*

Queen Yrsa is the king's second wife, and half his age. At the time of her betrothal, she was the butt of jokes and derision: a pretty young thing marrying an old goat for the express purpose of

whelping legitimate heirs. In the four years since her marriage, the jokes faded. She has won an astonished respect from most of the jarls, and the genuine love of many of her subjects. Because she bore two sons in quick succession, King Hord is utterly devoted to her; because she is intelligent and astute, he listens to her.

Her popularity is only weakened by her sometimes unconventional ideas and by her determined progressiveness. Staunch traditionalists see in these traits a desire to make Ostland just like the other nations of the world, forsaking the ideals and culture that made the Northlands what they are, but most of the populace sees the new possibilities she raises for the good of all. The entire political situation is in flux, and thick with intrigue.

Yrsa deals well with the intrigue. Her half-sister, Gunnhild Svalasdottir, is jarl of Suddmore, which has always been a powerful clan in Ostland. Gunnhild held a teenaged Yrsa as a hostage for a year on the grounds of doubtful loyalty to her clan, and planned charges against Yrsa for conspiracy to depose Gunnhild as clanhead.

However, even from confinement, Yrsa managed to stay in touch with her influential contacts. When Gunnhild made the charges of treason public, Yrsa took steps to clear her name. Accounts differ on the actual events following the proclamation of treason but, in a stunning and unexpected reversal, Gunnhild abruptly retracted her charges, freed Yrsa, and publically showered her with gold, apologies, and assertions of lifelong affection and admiration. Gunnhild has been one of Yrsa's most determined supporters since the young woman became queen.

Yrsa's Machiavellian abilities defend her and her vision from being swallowed by the lesser minds around her. Yrsa traveled out of the Northern Reaches as a young child (to keep her out of Gunnhild's way), and she brings an expansive, tolerant vision to her rulership that neither Asgrim nor her husband can match. She knows Ostland will sink into a barbarian backwater if it cannot modernize its ways. Even so, she respects its history

and traditions, and understands the desire of many to retain their unique northern way of life.

Queen Yrsa is careful and adroit in balancing one faction against another, and she rarely makes political mistakes. She is schooled and admirably knowledgeable in the rituals and teachings of Odin's worship, and therefore combines both secular and religious power in one figure. Her scholarship has earned the guarded respect of Asgrim and his fellow clerics, but her politics threaten the power of the priesthood, bringing her into direct competition with Asgrim who also seeks to unite the power of cult and state under his own leadership.

Yrsa shares her counsel and influence judiciously with the jarls who can appreciate her talents and her pro-development designs; thus she has earned their support in return. She works slowly, and plans for the long term. Her rank as queen allows her to exercise her political influence more openly than Asgrim. She can be as ruthless as the High Priest, but her manipulations are said to demand the best from her victim—a clear difference from Asgrim's chosen methods of squeezing his victims between their own weaknesses and the threat of public exposure.

Yrsa is young and her will is strong. If brought to fruition, her resolution to bring Ostland out of its barbarian past and into the mainstream of modern nations might make Ostland the heart of a rich, productive, vigorous world power.

**DM Note:** Queen Yrsa may be a little ahead of her time or just born in the wrong country, but her vision is worthy of a Charlemagne or Elizabeth I. Her star rises and the priesthood's wanes, but she must use all her intellect and political talent to ensure her balance as she walks a fine tightrope into the future.

Ostland is a nation where great change is possible. The presence of strong-minded, assertive adventurers (native or otherwise) could shift the delicate political balance. Relatively minor actions in support of either Yrsa or Asgrim's policies can have far-reaching results.

Left undisturbed, Yrsa's power is likely

## The Court of Cnute



to expand unless she is assassinated. Her greatest challenge comes from a small core of reactionary traditionalists who favor Asgrim's old-style religion over Yrsa's various plans for reform.

Yrsa can accommodate the priests' power within her own, but the reverse is not true. Asgrim would find it difficult to have her around if he winds up top dog, because Yrsa will not accept being a powerless figurehead. And although King Hord's interest in rule lessens, he still remains a powerful factor through the might of his military arm. In his absence, the military factions might themselves take Alexander's solution to the Gordian knot of court politics—if they could stop fighting among themselves.

### The Royal Compound

1. **The Great Hall:** The king's Great Hall embodies much that is traditional in the gathering halls of the northern peoples. A stone-lined firepit fills the center of the hall, which is built of stripped pine timbers caulked with mud and moss. The dirt floor never completely dries out, contributing to the miasma of odors— cold, damp molds, energetic unwashed bodies, and the more pleasant smells of wood smoke and freshly-laid straw mixed with herb grasses. Only outsiders will notice; to locals, these are the smells of home.

Recently the Great Hall has served as nothing more than a feasting hall, but every meal is a lively social event. Typical encounters here include: nobles and adventurers petitioning permission for a colonizing expedition to the Isle of

Dawn; certain jarls answering charges of treason; or squabbles between the Brothers of King and the Ravenguard berserkers. Two-Ox Charlie, the king's pet troll, is another likely encounter. He carries food to the king, he might wrestle five men at once for the audience, or he may recite poetry.

Banquets are served from the sideboards along the wall behind the king's table (referred to as the high table). The rear entrance from the kitchens has been enlarged to permit Two-Ox Charlie to carry in a fully-laden.

The high table accommodates up to seven: the king, queen, and a designated guest of honor have individual chairs, and everyone else sits on benches. The long trestle tables flanking the firepit seat about twenty each, on benches. The clanheads or their representatives are the usual company, but the king aggravates the Brothers and the Ravenguard by occasionally feasting with one group, then the other. Thralls move between table and firepit, and those who are insufficiently agile may be tripped into the coals for a laugh. Against the easternmost wall is a bench for guards and servants. The location is undesirable because the wall backs against the latrine outside, and the caulking in the wall is inadequate.

2. **The Queen's Court:** The court is divided into two spacious rooms. The larger outer court serves different functions as required: an antechamber for those waiting for an audience, a gathering hall for general councils and announcements, and as an entertainment hall. Formal audiences take place in the

smaller inner court.

Typical encounters here might include sages, mages, skalds, and charlatans seeking the Queen's favor and patronage. People like these may be hidden resources—or traps—for PCs.

The Queen's Court has been renovated in recent years. Planking covers the interior walls, and intricate carving adorns the interior posts. The outer court has a packed gravel floor which is covered with the traditional scatter of staw and herbs, but the inner court floor is one of Yrsa innovations: a white lime plaster overlays the gravel foundation. Although this combination makes the room uncomfortably cold in the damp climate, Yrsa feels this encourages swifter thinking from petitioners.

3. **The King's Hall:** The king's private quarters are in keeping with traditional dwellings, although King Hord enjoys the comfort of planked floors and walls. The large outer room (A) functions as the king's private meeting room, although it more often serves as his drinking hall and gaming room.

The king's sleeping quarters (B) include the bed he occasionally shares with the queen, and his chests of personal belongings. He keeps a worktable and chair against the west wall for what statecraft he remains involved in, but he relies ever more heavily on verbal reports and the opinions of those around him. His armor and weapons are racked on the south wall.

4. **The Queen's Hall:** Renovations of the Queen's Court were extended into the queen's private quarters. Planking covers the walls and the floors alike, and the rooms are therefore warm and clean. Traditionalists point out that the queen is unnaturally obsessed with privacy— her rooms are partitioned off from one another in the southern manner. Her interior fireplace and chimney are poorly constructed, having been built by workers willing but unfamiliar with the design. Her rooms are often smoky, and those who share this part of the building are particularly susceptible to colds.

The outermost room (A) is a sitting room, and the queen often conducts semi-private business from this antechamber.

Only trusted advisors, or those accompanied by such, enter this room. Yrsa's sleeping quarters (B) are not elaborate, with a small dressing chamber to one side. Chests along the walls contain her personal belongings: clothing, jewelry, and cosmetics.

Another of the queen's innovations is an interior lavatory (C) which vents to the outside. Facilities are still minimal by more civilized standards.

The upper wall of the southmost room (D), a solarium workroom, can be opened to admit the sun on pleasant days. The queen and her ladies work in the western half of the room spinning, weaving, and doing the needlework incumbent on females of every rank in this culture. On the other side of the room, shelves overhang a table where the queen works, often late into the night, on state matters—reading reports, designing public works, and reviewing judgements.

Three thralls share a small room (E). Two are personal servants to the queen, and the third is the princes' nursemaid.

The two infant princes, Finn and Geir, live in the nursery (F) across the hall from the queen's quarters.

**5. Barracks of the Brothers of the King:** Twenty select warriors sleep, eat, and store their belongings here, where they are tended by their servants. Six of the warriors are female. All live for the king, and all consider themselves above the law. The group's captain is presently Beowulf Stonehand.

**6. Temple of Odin:** An elaborate structure all of oakwood, the temple contains a small shrine dedicated to Odin. The walls and posts are richly decorated, and the best-known power runes are inscribed on the upright rock beside the shrine itself, which contains a bust of the god. A full set of oaken rune-tiles is kept in a silver bowl beside the stone.

The rear of the building is partitioned off as living quarters for Asgrim and his staff. The High Priest himself spends much of his time away from the temple, conferring with the king or others.

**7. Thralls' Quarters:** Ramshackle huts, none too tidy, and an open-air kitchen fill the area. The slaves of the royal house-

hold live here. Two-Ox Charlie, the king's pet troll, has a lean-to against one wall, but no one argues with him when he decides to sleep somewhere else.

### The Lower Fort

**8. Barracks of the Personal Guard:** This 900-man elite brigade is led by Brand the Peacock, so named for his love of fine dress and decoration. All are intensely loyal to the king.

**9. The Shrine of Mjolnir:** A shrine dedicated to Thor, it is also the barracks of the Ravenguard berserkers.

**10. Granaries:** The Court of Cnute maintains granaries against a bad harvest season, delivered as tribute from the jarls of Ostland. The building closest to the Royal Compound doubles as the king's treasure house. Guarded by the Personal Guard.

**11-34. The Clan Houses:** Each of the ruling clans of Ostland maintains a Great Hall outside the walls of the Royal Compound. These are the residences of the entire ruling jarl's family in winter. Hostages remain in residence year round.

**35. The Foreigners' Compound:** Whether hopeful merchants or foreign ambassadors, all outlanders are confined to this area except when in the company of a noble Ostlander or the well-known and trusted servant of such. Non-natives are never allowed to wander unattended, and even when accompanied, strangers may be challenged by any warrior. The district is supervised by the Guard.

The general "city" known as Zeaburg is an unplanned scatter of freemen's residences: craftsmen, farmers, fishermen, and laborers. At the pier tribute is delivered, and warships can embark warriors and supplies. The guard towers are staffed by the Personal Guard.

### A Campaign Framework

To run an effective FRP campaign, DMs need an effective campaign *framework*, a group of gamemastering techniques which link the short-term excitement of individual adventure scenarios into large-scale, significant actions and themes. Campaigns have common elements for

an effective framework:

1. Distinctive, powerful recurring characters. Significant patrons, informants, allies, and/or opponents whose actions and motivations often shape individual campaign scenarios.

2. A campaign home base. Here the player characters meet before embarking on an adventure, and have a safe haven to return to for healing after their ordeals. (The "tavern" or the "palace of the Duke" are common FRP home bases.)

3. Standard scenario beginning and ending routines which link individual scenarios into the larger campaign. (For instance, many campaign scenarios begin with a wizard or duke gathering the player characters to give them a task; when the task is complete, the player characters return to receive their rewards—or a tongue-lashing—from their patron, who then explains there is more to be done.)

4. Powerful themes and narrative backgrounds—stirring, dramatic questions of good and evil, right and wrong, that give special meaning to the lives and actions of the player characters.

In the Ostland campaign, King Hord, Asgrim, and Yrsa are the distinctive, powerful recurring characters. The Court of Cnute becomes the PCs' home base, where they receive missions from Hord, Asgrim, and/or Yrsa, and where they return for healing and rewards. Most scenarios will begin and end at the Court. And finally, the conflict between Asgrim's drive for absolute power and Yrsa's vision of a modern nation where all political interests are fairly represented provides the background for the PCs' gradual increase in power and influence. Their achievements gain significance, not just in terms of personal wealth, but in terms of how well they can protect Ostland's people from Asgrim's ambitions, while aiding Yrsa in bringing Ostland out of its barbarian youth and into a civilized maturity.

### An Ostland Campaign Outline

Ambitious, adventurous Ostlanders (new characters beginning in the Northern Reaches campaign) are drawn to the

## The Court of Cnute

Court of Cnute by rumors and open advertisements announcing the king's desire to sponsor adventurers. Upon arriving and applying to the king, the characters are invited to accept Hord's hospitality, in return for various services to be named at a later date; these services will become the first adventures in the Northern Reaches campaign. (For examples of scenario ideas, see "The Kingdom of Ostland, Current Events," page 13.)

In this early phase of the campaign, the PCs will first receive a mission—and perhaps some useful support, like a magical item or a skilled NPC companion—in an audience with King Hord. Then the characters are interviewed by Asgrim and by Yrsa. At this stage, both are polite and helpful, offering the use of little clerical items or NPC advisors, while making no demands on the characters.

After the PCs complete their missions, they return to King Hord—and Asgrim and Yrsa—to receive their rewards for accomplishing the assigned tasks. Thus all adventures will begin and end with the DM playing the three personalities of Hord, Asgrim, and Yrsa. The DM begins with a mission assignment, granting aid, and ends by debriefing and delivering rewards (payment and assignment of experience points for accomplishments).

In the second phase of the campaign, when the characters have reached approximately 4th–6th level, the king may continue to dispatch the PCs on missions, but the assignments will sometimes be more subtle and complex. For example, King Hord may send the PCs to Ostmanhaven to search for evidence of plots against the royal house, or he may send the PCs to investigate rumors that Vestland and the Jarldoms conspire with the Alphatians to support the Ostman clan in a revolt against the Cnute's rule.

At this point Asgrim and Yrsa begin to make special personal requests, and offer more substantial rewards. The PCs should begin to realize that the three main characters have competing political interests...

The king just wants to live a life of glorious warfare and adventure through his loyal subjects. Hord still offers the PCs heroic tasks, but his bloodthirsty person-

ality becomes increasingly repellent.

Asgrim wants to consolidate the power of Ostland under puppet monarchs controlled by an enlightened statesman—Asgrim himself. The High Priest is increasingly generous in his aid to the characters, requiring in return no more than simple favors—messages delivered, special considerations to friends of Odin, little services for the cult. At the same time, Asgrim hints subtly that Hord is losing his grip on the rulership of Ostland, and that the cult of Odin, under Asgrim's guidance, would be a perfect regent to protect Ostland's future.

Yrsa wants to insure that she rules Ostland after Hord's death, as regent for her sons or as sponsor of a fosterling if that proves necessary. She is less motivated by the desire for personal power, but she fears Asgrim's obsession with achieving absolute control for himself. She, too, will offer more generous assistance to the PCs, but will make greater demands on them, also. She warns against allowing Asgrim and the Odin cult to become too strong, and her requests will involve keeping tabs on Asgrim and his minions. At times, she may require that the PCs secretly work to foil the plots of Asgrim directly.

In this second phase of the campaign, the scenarios are still mostly monster-stomps and treasure-grabs, but minor political elements begin to crop up in Hord's assigned missions. As evidence mounts that Asgrim and Yrsa are struggling for control of Ostland in the midst of King Hord's deterioration, the PCs realize that sooner or later they must choose sides in this conflict. Their choices should be the deciding factors of who rises and who falls.

In the last phase of the campaign, the PCs have reached name level and may be seeking their own dominions. King Hord's mind is failing him, and it is clear that Ostland must have a new ruler. Both Yrsa and Asgrim promise the PCs their own dominions and positions of power and influence in return for support in the struggle. The PCs are caught in the increasingly direct confrontation between Yrsa and Asgrim; to give aid to one is to openly declare the other enemy.

By this phase, most of the PCs' adventures may have political overtones. Even a simple treasure-grab scenario requires the PCs to reveal their political loyalties, since Asgrim and Yrsa will each request that the treasure be placed at their disposal to permit them to "save Ostland from disaster." At the same time, once the PCs openly or secretly declare themselves for one party, the other party is plotting to destroy them, and the PCs may be forced to strike back in self-defense.

The first crucial event in this final phase of the campaign is the death of Hord. Ideally, the PCs should be present for this event. For instance, Hord might insanely insist on leading an invasion of Ostmanhaven, and be slain in a challenge combat with the Ostman clanhead. The invasion would collapse under the confusion of the factions struggling for power, and the invasion fleet would return to Ostland.

In the climax of the campaign, the PCs find themselves involved in a civil war between Asgrim and Yrsa, the traditionalists vs. the progressives. Perhaps Asgrim kidnaps the infant princes or Yrsa, holding them hostage. Perhaps Yrsa and the princes flee to exile in Ostmanhaven, where they seek alliances with Vestland and the Jarldoms to permit them to return to Ostland as rightful rulers. The PCs might play a number of roles in the civil war, both as plotters, agents, and heroes, or as generals in large-scale military confrontations using the BATTLESYSTEM™ Fantasy Combat Supplement or War Machine data (in the D&D® Companion Rules).

Assuming that Yrsa and the PCs triumph over Asgrim, the PCs might then be retired as high-ranking NPC nobles and advisors in Queen Yrsa's court. If the characters are to be kept in play, they might continue in high-level wilderness and outer planar exploits while involving themselves in diplomatic missions to the noble courts of Karameikos, Glantri, or Thyatis, or they might choose to move on to a new setting, like the Isle of Dawn colonies, or the vast wildernesses north of Norwold, in search of suitably challenging adventures.

## FALUN CAVERNS

Falun Caverns is an adventure setting for immediate use. Use the "Gnomish" Falun Caverns map on page 32 of the Players Book as a player handout. The DM's reference map to Falun Caverns is printed on the inside cover. Use this as a DM reference and gamemaster screen while running Falun Cavern scenarios.

The DM can choose precisely where in the Northern Reaches he or she wishes to locate the Caverns, but we recommend starting the players in Castellan or in Whiteheart (both in Soderfjord). This is a good opportunity for DMs to use a standing runestone to start the adventure off—a weathered block inscribed with hints about the ancient gnomish village in the hills nearby. More simply, the PCs may be pursuing kobold raiders to their lair—a pursuit which ends in the Falun Caverns.

## The Maps

The layout of Falun Caverns is based on a real cave—Jewel Cave National Monument in South Dakota. The Falun Cave map represents less than a tenth of the size of the Jewel Cave map; imagine even more extensive caverns extending to the south and west which could be further developed.

The writing on the player's handout map is an unintelligible runic script. This is "Auld Gnomish." The mapmaker used a *wish* to prevent the Auld Gnomish runes from being read by magical means. Only another *wish* can alter this condition.

The DM's map includes translations of the Auld Gnomish. Industrious players who like word puzzles will find that the Auld Gnomish script is a replacement code for the English alphabet. (See the chart on the DM's map.) Players who figure out the replacement code can translate the Auld Gnomish notes in full, and gain valuable information about the cave.

Players may have a little trouble getting started decoding the Gnomish script. In the spirit of enjoying a good game, the DM can point to logical places

to start, like the scale, the compass rose, or even the map title. These clues can be provided directly, or the DM can introduce a gnomish informant who "can't quite make it all out," but who might recognize select letters or words.

Some players hate word puzzles, and will refuse to work out the Gnomish writing. That's fine. In that case, the full translation on the DM's map is your joke; you know what they're missing.

## Ancient Falun Village

The Falun Caverns region was inhabited by the Northland gnome culture for centuries before it was conquered and destroyed by kobold invaders in 490 AC. Over two thousand gnomes once lived in peace in several underground villages; very few survived the invasion. A kobold community of 200-300 individuals has lived in Falun ever since.

## Gnomish Engineering

Gnomes used a complex technology of alchemical processors to dissolve the limestone. They transported it to an array of molds and forms, and molded their structures in place, relying heavily on pipes, braces, and scaffoldings. Foundations are mortared stone or reinforced fiber forms synthesized from organic cave resources like slimes, jellies, worms, and ants.

The resulting structures look like molten glass or plastic poured over bizarre frameworks. They are decorated with flowstone curtains and other calcite formations, variously colored with bright mineral pigments. Some sections are still lit by ancient *continual lights*, dating from the gnome occupation. Some artificial formations are lit from within by these *continual lights*, creating subtle shadings and prisms of color.

There are two basic types of gnome structures: villas and guild halls.

Villas are apartment complexes which housed from 20-100 gnomes. There are three main styles: high-wall, with many units up the walls to the ceiling; cylinder, multiple units in floor-to-ceiling towers, with walls left for murals; and low hut,

clustered single units common in the low chambers.

Craft guild halls were communal factories, with workshops and residences for guild members. Acceptance into a craft guild brought the benefits of free housing and various exclusive privileges. Producing fine goods is still a prestige occupation among gnomes, and the guilds of Falun were more elaborate and luxurious than ordinary gnome residences.

The ancient gnomes lived on many levels of the caverns, with structures rising to the ceilings high above the cave chamber floors. Their villages were wonderlands of Rube Goldberg-like conveyor belts, trolleys, counter-weighted ramps, and elevators. All these devices are now derelict and frozen in natural flowstone deposits, but they can still inspire awe.

## Gnome Agricultural Caverns

Originally lit by *continual light* bulbs, the algae, fungus, and other cave-adapted plant life raised on these farms provided the bulk of the gnomes' nourishment. Now scattered descendants of the original plants remain. The rest of the caverns show evidence of the formerly lush growth, where flowstone has captured and mineralized the deteriorating remains of fields grown wild in the absence of their tenders.

Many areas have been taken over by the kobolds, who have added more *continual lights*. The lighting is far inferior to the original gnome illumination, and only mushrooms and mold grow now.

## Artifact Collecting and Salvage

Gnomes used flowstone and organic fiber as the modern world uses metal and plastic. With these materials, gnomes manufactured a bewildering variety of devices. About a quarter of these devices are roughly analogous to the kind of objects we twentieth century humans can buy in shopping malls or from store catalogs. The rest are either pointlessly complex elaborations of items one would normally find useful, or pointlessly complex designs with a purpose and function

## ADVENTURES

known only to the original designer.

Most useful artifacts have been plundered long ago by the kobold invaders. The remaining relics are often covered by various calcite deposits. Kobolds have no skill extracting artifacts from the deposits, but the magic user's *rock-to-mud* spell will do the trick. Skilled miners and would-be archaeologists may physically remove objects with the proper tools, lots of patience, and a delicate touch.

Areas where gnomish artifacts may be recovered are indicated on the DM map of Falun Caverns (inside cover). See page 43 for charts of artifacts to be found in the Falun Caverns. For more elaborate devices, see the *Book of Wondrous Inventions* (AC11), which offers plenty of bizarre artifacts that might lie buried in the centuries-old flowstone deposits. DMs may also wish to create their own items for PCs to find.

### Creatures Once Domesticated

Gnomes raised ants as draft and pack animals, and mules for riding. Bats, rats, and giant ferrets were raised as domestic and working pets. Various cavern creatures, such as giant beetles, rats, and purple worms, were raised for food. Most of these species run wild in the caverns, and some "herds" are still maintained by the kobolds.

### Burial Grounds

Kobolds fear dead spirits' vengeful ancestors, who they believe watch over properly prepared graves. Thus, the kobolds avoid gnomish burial grounds. The barrows and catacombs are relatively undisturbed, though often buried in heavy flowstone. Traditionally, gnome possessions are handed on to clan and guild, so bodies are buried without important grave goods. Burial grounds are empty of valuable plunder.

The unburied gnome casualties of the kobold invasion were treated more casually—they provided food during the establishment of the first kobold settlement. However, a victim's ancient remains are occasionally found in an out-

of-the-way spot, overlooked by scavenging kobolds and covered with flowstone deposits.

### Map Key

The following map key lists all map references, with brief descriptive notes. The listings are alphabetical to help you find entries quickly and easily.

- **Algal Processing:** Factories where algae was flavored, textured, and packaged in flowstone or fiber containers for distribution and storage. All ruins.
- **Ant Ranch:** Draft stock was corralled here. Ruins. Ants now range freely to the north and west.
- **Arch Villa:** Residential high-wall apartments, stripped by the kobolds and abandoned. Heavy flowstone covers much.
- **Auld Barrow:** Ancient burial ground, dating from gnome pre-history. Heavy flowstone everywhere. Kobold taboo.
- **Auld Falun Village:** Earliest gnomish habitations in Falun Cavern. All huts are of mortared flowstone fragments. These oldest gnomish huts are similar in design to primitive human stone dwellings.
- **Auld Villa:** Low hut residential apartments built in old mortared stone fashion. Stripped by the kobolds, then abandoned. Heavy flowstone.
- **Barrow Way:** A more recent gnomish catacomb, in use when the invaders came. Light flowstone. Kobold taboo.
- **Beetle Ranch:** This was a small operation for specialty meats; other beetle ranches were usually larger. Wild beetles now range north, west, and east; they are hunted by kobolds for food.
- **Bluecaps:** Gnomes in Falun relied on the Bluecaps, a news and messenger service like the Pony Express, to stay in touch with their kin. Surface routes between settlements were often dangerous but more direct, only used by gnomes in a hurry.
- **Boulevard:** Elaborately decorated main hallway, with flowstone sculpture and murals. There is heavy flowstone

damage, but the murals are still impressive. Faded gnomish lights are supplemented by kobold lights. A well-traveled, paved surface, this is a preferred route to the kobold settlement.

- **Breezeway:** A long chamber with very high ceilings. Ruined, crumbling catwalks and high observation platforms are poorly lit by fading gnomish illumination. Lower course lit by recent kobold lights from Boulevard east to the kobold settlement. Ruins of Founder College are here.
- **Crystal Falls:** Beautiful flowstone terraces, curtains, waterfalls, and pools, dimly lit by ancient gnomish lights. Paths toward Fishstone Mall and West Farms are covered by streams and flowstone, and very dangerous to use.
- **Culay Village:** Ruined gnome village eight miles east along an unlit, unimproved path. There's a small kobold settlement at Culay, and this route is occasionally taken by kobold war parties.
- **Falun Center:** Arts and entertainment center of the gnomish settlement. Great stadium with small performance rooms on lower levels. Stripped, vandalized ruins. This area is now used as a beetle farm.
- **Falun Feast Village:** Low hut farming and residential village. Ruins. Partially stripped by kobolds. Light flowstone. Area is avoided by kobolds because an aggressive, territorial ant colony roams the vicinity.
- **Falun Village:** A large, town-sized gnomish settlement, with ruins of several residential craft guilds, a college, and an arts center. Now the site of the main Falun Caverns kobold settlement.
- **Fiber Guild:** This guild produced fiber products for manufacturing and construction. Ruins. Stripped and abandoned. Moderate flowstone. Kobolds used salvaged fiber stocks for their earliest constructions in the kobold settlement.
- **Fishstone:** Cylinder-style residential apartments. Called Fishstone for the brightly-colored flowstone walls, sculpt-



ed into fish forms.

- **Fishstone Mall:** Open fairgrounds in a high-ceiling chamber. Heavy flowstone, poor lighting, difficult access, and little visited by kobolds.

- **Fishstone Park:** Public park along West Pool and White Canal. Heavy flowstone. The floor is flooded by a canal which has overflowed its banks. A nearby shrine is badly ruined by flowstone, but it has not been stripped.

- **Flood Zone A:** Long passage leading down to flooded regions. Very slippery, with seeps and thick algal growth.

- **Flood Zone B:** This region flooded just before the gnomes were exterminated by the kobolds. Several submerged gnome residences here have not been stripped, and constant flow of water has prevented flowstone deposits. A treasure trove of gnomish artifacts in good condition.

- **Founder College:** Center of gnomish education and scholarship at the time. Libraries and collections are stripped or vandalized by kobolds. Nothing of value remains. However, ruins are extensive and complex, no longer visited by kobolds—a good hiding place for PCs on the run.

- **Friendship Guild:** Very large care community for elderly and disabled gnomes. Gnomes are known for their generous treatment of the old, sick, and disabled, and Falun Village was the site of the largest Friendship Guild in the region. It is now ruined, stripped, and vandalized by kobolds. However, the ruins of the Health Care Center still contain several clerical healing and curing artifacts overlooked by the kobolds.

- **Gadget Guild:** The Gadget Guild produced an vast array of devices, most of them far more elaborate and complicated than warranted by the function they serve. For example, the equivalent of a can opener had fifteen different settings, weighed eleven pounds, and required three hands to operate. There are thousands of items like these lying around the ruins of this guild. Many have been

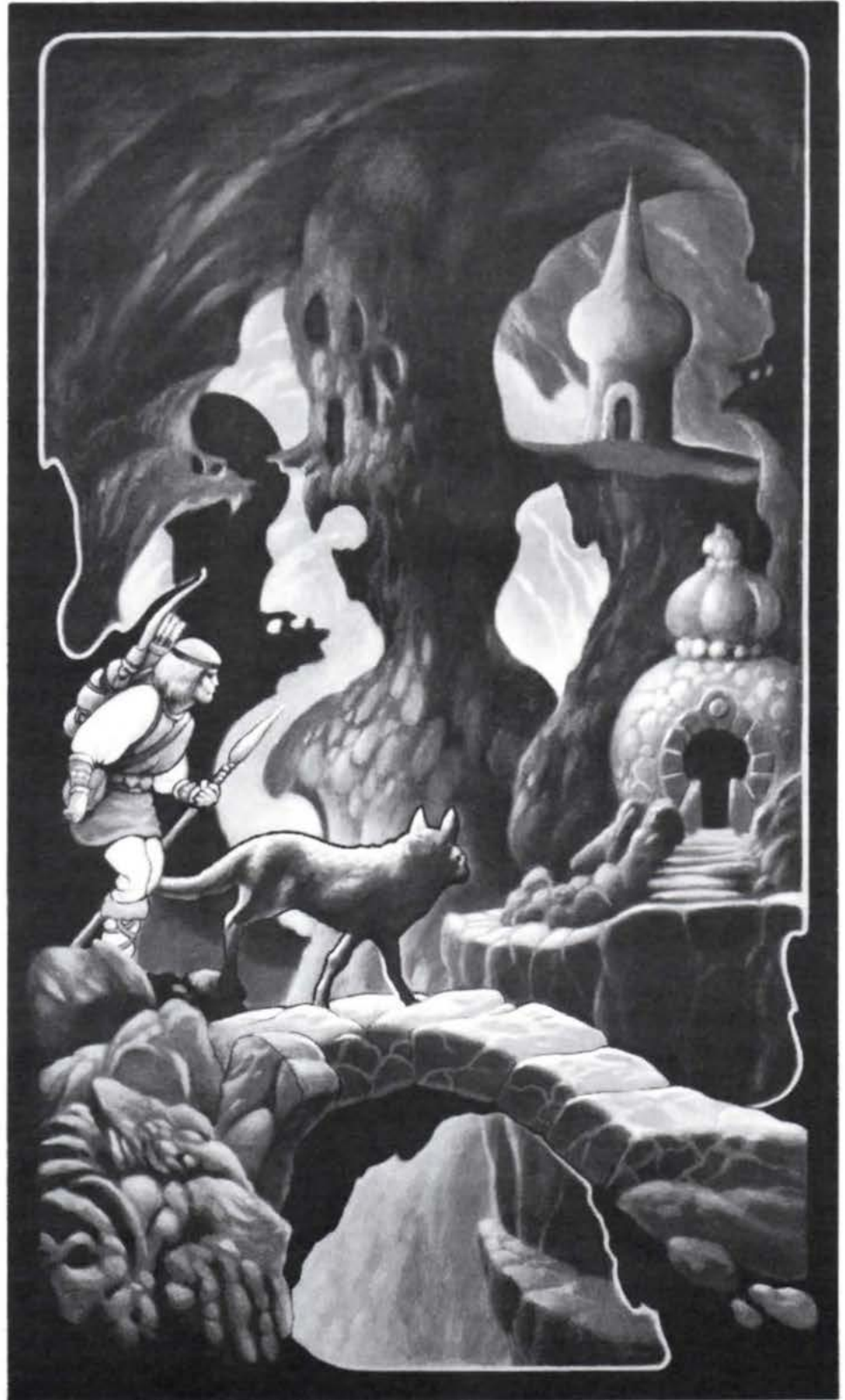

## ADVENTURES

abused by frustrated kobold scavengers, and most are damaged by flowstone and corrosion.

- **Gate Watch:** Gnome guards occupied this chamber above the main entrance. Ramps lead to observation platforms which overlook the passage below. This room is now used as a watch station by kobolds observing traffic entering the caverns.

- **Green Canal:** This canal brought water to the algae colonies of West Farm. The area is now farmed for fungi and molds.

- **High Loft:** This unlit chamber has a ceiling only three to four feet high. It was used by the gnomes as a garbage dump. The refuse was periodically cleared away and taken outside the cavern for permanent disposal. Kobolds may use this chamber to outflank invading PC parties.

- **Jelly Farm:** Catwalks through this area are suspended over pools where various cave jellies, puddings, and slimes were cultivated for their chemical components. A small processing plant lies in ruins at the southern end of the chamber. The former inhabitants have now grown wild, feeding off one another, and off beetles and ants that stumble into this area. The kobolds avoid the jelly farm altogether.

- **Lower Ant Ranch:** Stocks of food and fiber were stored here originally, but anything useful was taken early on by the kobolds. Lower levels in this direction are presently inhabited by a vast ant colony, the descendants of the gnome domesticated stock. These ants are numerous, territorial, and hostile.

- **Machine Shop:** The Machine Shop is a public facility where gnome citizens could bring malfunctioning devices and work on them, with tools and advice provided by resident experts. Gnomes often lost interest in the malfunctioning devices, but refused to throw them away. Many were stacked, tagged, in storage bins. The PCs can find innumerable broken and useless devices scattered around by impatient kobolds. Other items are covered with light flowstone deposits.

- **Magic Guild:** Magic was and is a less prestigious craft than general gadgetry among the gnomes, so this was a modest magicians' guild. Ruins, moderate flowstone. Kobolds have stripped the area of everything that detects of magic.

- **Marble Villa:** Cylinder-type residential apartments. Ruined. Heavy flowstone.

- **Meat Processing:** Beetles and worms were processed, textured, and packaged for food, then stored in fiber or stone containers. Machinery and buildings are ruined. Intensively scavenged by kobolds. If still sealed, remaining containers may have edible but nasty-tasting meat.

- **Metal Guild:** The buildings have been preserved and occupied by kobold warriors. Dire wolves are corralled along chamber walls. Beetle meat is brought in several times a day from farms in the Falun Center and Service Guild areas.

- **Mikal Park:** A cavern wilderness area preserved by the gnomes for sports and recreation. Kobolds hunt cave creatures and gather fungi from this area now.

- **Mule Ranch:** Gnomes raised mules as riding animals. Few mules survive in the vicinity, though their bones lie buried in heavy flowstone here.

- **New Villa:** High-wall residential apartments. Ruined. Heavy flowstone.

- **Police  $\Delta$ :** Barracks of the gnomish internal security force who doubled as a mule-riding defense force patrolling the upper world as well. Police duties for each village were handled by local guardsmen. Area was stripped and vandalized by kobolds. Light flowstone.

- **Power  $\Delta$ :** This area contained an experimental power generator (magical) intended to replace the *continual light* illumination in the caverns. The project was abandoned, deemed unsafe. Kobolds who forced their way past the entrance were baked by lightning bolts. Though the kobolds detected massive quantities of magic, they wisely chose to abandon it. The generator still draws electrical energy from the Ethereal Plane,

and anyone entering the room is struck by a 6d6 lightning bolt.

- **Quiet Rest:** Low hut residential apartments. Ruined. Moderate flowstone.

- **Rat Nursery:** Gnomes raised rats for food, as pets, and as trained draft animals. Wild rats are found in profusion throughout the caverns. They are hunted by kobolds, and also raised domestically.

- **Redcap Village:** A small residential and farming village. Ruined, stripped and vandalized. Heavy flowstone.

- **Rust Shelf:** Once a small gnomish rust monster farm, now a wild colony. Wild rust monsters wander throughout the caverns. They have learned to avoid kobolds, who hunt them for food.

- **Service Guild:** This complex housed the equivalent of the gnomish civil service. Ruined. Stripped and vandalized. Now the site of a kobold beetle farm.

- **Slide Wall:** Originally, the Falun Caverns entrance was sealed by massive, camouflaged mechanical doors. These doors failed, and were sealed open by kobolds. The entrance is now concealed by dense forest growth.

- **Slime Pools:** Gnomes cultivated cave slimes for their chemical properties. These pools now contain wild slime colonies. Kobolds avoid this area, and many artifacts remain in good condition.

- **Stable:** Mules for the police and Bluecaps were stabled here. Stripped and vandalized. No flowstone.

- **Stone Guild:** Once home to flowstone workers and cave engineers. Buildings were preserved and are now occupied by kobold serfs.

- **Suburbs:** Northeast of Redcap Village lie several more residential and farming villages. All are stripped, vandalized, and buried in heavy flowstone.

- **Test  $\Omega$ :** These areas were reserved for testing of magical devices and gadgets. The chambers still bear the evidence of explosions and other minor disasters. The rooms still detect as magical, and are avoided by kobolds.

- **Upper Fishstone:** Low hut residential apartments. Ruined. Moderate flowstone.
- **Vaults:** Warehouses for agricultural and manufacturing materials. Stripped and vandalized by kobolds. Beyond these vaults, wilderness caverns extend for miles. Kobolds have not charted this cavern area, and avoid it because of dangerous cave wildlife.
- **West Farm:** Formerly the main algal farm for the Falun Village region. Kobolds farm mushrooms and other fungus.
- **West Pool:** A beautiful, shallow pool beneath Crystal Falls in Fishstone Park. Gnomes used this as a wishing well. A modest fortune lies buried in flowstone beneath the black surface of this pool.
- **White Canal:** This canal leads through the Fishstone Park area. It overflows its banks, covering the cavern floor in water six to twelve inches deep. Footing is very treacherous.
- **Wind Way:** This passage was little used by gnomes and retains the appearance of a wilderness cave. Kobolds may use this route to outflank PC invaders.
- **Wishbone Villa:** Luxury high-wall residences. Ruined, stripped and vandalized. Heavy flowstone. Several treasure hoards still lie well-protected, though they could be detected only by magical means. Excavation would require plenty of manpower or magic.
- **Worm Fields:** Gnomes maintained these low regions for wild worm colonies. Worms were hunted for meat, and worm hide was prized by the Fiber Guild.
- **Worm Nurseries:** An experimental worm-breeding project. Several peculiar worm species may be found in this area, descendants of gnomish experiments.
- **Worm Ranch:** Gnomes raised worms for food and organics. No worms remain. Area occupied by kobold serfs and nobles.
- **Ω /Danger:** This symbol is prominently displayed to indicate natural and

gnome-made hazards.

- **// /Passage Blocked:** This symbol means that the passage is temporarily blocked or under construction.
- **△ /Restricted Access:** Authorized gnomes only. Generally locked or otherwise protected. Areas marked thus on the map may have been entered by kobolds, but undamaged compartments bearing this symbol in ruined gnome buildings may not have been plundered.

### Artifact Tables

Artifacts marked in Auld Gnomish can be translated with *read languages*. Two values are listed for each item. The first is for sale as an antique oddity in any market town. The second is for sale to a knowledgeable collector, an interested sage, or a school like Uppsala College in Norrvik. DMs may alter prices up or down, depending on the perceived value of similar items in any given campaign.

If skill and time are required for successful extraction, make a secret skill check for the PC directing the extraction. Then ask the player how long his character is willing to spend extracting the object. Roll to determine time period necessary to successfully extract the object.

If the skill check is failed, the object is destroyed in the process of extraction. Circumstances should dictate whether you tell the player until he has spent the time digging it all the way out. (The character might be able to tell that the item is ruined after getting it halfway out—or half out!)

If the PC spends more time than necessary and passes the skill check, the object is successfully recovered.

If the PC passes the skill check, but spends less time than needed for safe extraction, he will obtain the object, but it is damaged in the process. Subtract the time spent from the time required. That result is the percentage of useful value lost. (If a PC spends 2 hours working to get something that takes 20 hours to get safely, the object loses 18% of its value.) If the value exceeds 100%, the object is

completely destroyed.

Players may say they will “take as long as necessary, and work as carefully as necessary.” This is reasonable, assuming the PCs do not have a prior reputation for ham-handed clumsiness and a love of shortcuts. Consider that there will still be a chance that a delicate object will be damaged beyond repair, no matter how carefully the person works. DMs can also keep the players on their toes by having cave creatures stumble onto the group at work. But above all, don't let play drag. These tables are to have fun with, not to make the game boring.

When PCs enter an area marked on the DM's map as having an artifact, and they make the effort to locate it, the DM must decide which of item is actually found. The DM should roll a die with the appropriate number of sides to determine what device has been located.

### Easy Recovery Table

(Twenty percent chance of discovery per hour of search; no skill or time needed to recover.)

These are small objects overlooked by kobold scavengers and, by rare luck, not covered with flowstone.

1. **Rat Whistle:** Used to summon pet rats, it now summons wild rats (50% chance of 1-10 giant rats while in Falun Caverns). 10 gp/500 gp.
2. **Continual Light Reflector:** Shaped like a flashlight, it focuses a *continual light* in a 120' cone of light, with the lit circle expanding to 10' in diameter before the light becomes too dim to see further. 300 gp/500 gp.
3. **Pocket Measuring Device:** Tape measure and weighing scales, calibrated in ancient gnomish runes. 1 gp/500 gp.
4. **Glassy Fiber Cube:** Contains six gnomish portraits, lit from within by a *continual light*. 10 gp/500 gp.
5. **Clear Fiber Flute:** Constructed like modern metal flute but resembling

## ADVENTURES

glass. Lots of buttons and levers. Requires extensive restoration before it will function properly. 5 gp/500 gp.

6. **Firestarter:** Flint-and-steel in a boxy device, hand-operated. 20 gp/50 gp.

7. **Fiber Container of Pipeweed Granules:** Halfling weed prepared for chewing; no longer palatable. 0 gp/300 gp.

8. **Fiber Container of Glu-All:** Twenty applications. Welds any substance to another substance. 500 gp/2000 gp.

### Difficult Recovery Table

*(Ten percent chance of discovery; mining or similar skills and tools required. Successful extraction requires 1d20 hours and successful skill check.)*

These items are embedded in flowstone, but are simple or durable enough they may withstand rough extraction.

1. **Foam Generator and Two Canisters:** Device like a fire extinguisher; sprays fiber-based foam which hardens in minutes into a rigid substance as tough as wood. 1d10 uses per canister. 500 gp/1500 gp.

2. **Worm-hide Gloves:** Fire and acid resistant, gnome-sized. 350 gp/1000 gp.

3. **Handbound Sheaf of Fiber Sheets:** Personal copy of gnomish fairy tales. Irrelevant nonsense. 10 gp/1000 gp.

4. **Pocket Pinball:** Hand-sized pinball game, good condition. 100 gp/500 gp.

5. **Coil of Thin Fiber Wire:** Strong as rope, 100' long, coils to 2" in diameter. 100 gp/500 gp.

6. **Sporting Crossbow, Repeater:** Six-shot fiber-based crossbow; can't replicate design without gnomish fiber technology. 1500 gp/1500 gp.

### Miraculous Recovery Table

*(Three percent chance of discovery; mining or similar skills and tools required. Successful extraction requires 1d100 hours and successful skill check.)*

These things are so massive, so complex, or so bewildering that the scavenging kobolds ignored them. All are easy to damage.

1. **Miniature Printing Press:** Has moveable type, Auld Gnomish runes, of course. Weighs 400 pounds and prints only on fiber paper. No instructions. 100 gp (as scrap)/10,000 gp.

2. **Perpetual Motion Device:** A turntable set on a cabinet full of pendulums, counterweights, and whirly-gigs; in perfect working condition. Two thousand-word Gnomish instructions on bottom of cabinet. Like all perpetual motion devices, this does nothing useful for a long time, then stops; INT check at -16 penalty to comprehend, even with instructions. 50 gp/2000 gp.

3. **Lava Lamp:** Clear fiber cylinder like glass, filled with viscous fluid and red globs of stuff. When heated on one end, globs zoom around in pretty patterns. No instructions. 50 gp/500 gp.

4. **Folding Bicycle:** Balloon tires have deteriorated and whole mechanism needs oiling. No instructions. 5 gp/2000 gp.

5. **Chronograph:** Pocket watch. Interior works hopelessly flowstoned, though *rock-to-mud* may clean it. The amount of repair to actually make it functional is beyond the abilities of readily available technologies—it would require the abilities of a moulder dwarf to even make the attempt. No instructions. 1 gp/5000 gp.

6. **Hand Calculator:** Bellows-driven like a bagpipe, its fiber bag is in poor condition. Instructions partially legible. 1 gp/1000 gp.

### CAVERN CREATURES

Kobolds learned much about domesticated plant and animal life of caves from their gnomish victims. Gnomes were particularly clever in raising slimes, molds, and other lower life forms, and employing the harvested products for various purposes. Most of this technology is lost to the kobolds. Vast labyrinths of cave rooms and passages

have been abandoned to colonies of these creatures now gone wild. Also, many wilderness cave species have moved into the gnomish ruins.

**Rust Monsters:** Raised by gnomes for their chemical properties, these unaggressive creatures now wander the caverns at large, avoided by the kobolds.

**Giant Ferrets:** Raised as hunting pets by the gnomes, ferrets are now common wild predators, feeding on rats.

**Giant Beetles:** Raised for food and fiber by the gnomes, these creatures run wild in the southern areas of Falun Caverns, and are hunted by kobolds for food.

**Giant Scorpions:** Found wild in lower cavern regions.

**Giant Spiders:** These dangerous predators were eliminated by the gnomes, but they have since have returned to plague the kobold settlement.

**Mules:** Gnomes raised these as riding animals. Wild varieties appear in remote northeastern areas, but they are preyed on by kobold wolf stock and so are uncommon.

**Gelatinous Cube:** The common name of this creature comes from the variety generally found as sentinels in man-made corridors. In a natural cave environment, the slime limpet (as the gnomes call it) takes many forms. It feeds on any organic substance—typically the algae in warm pools—but it also traps other creatures on its sticky exterior. Slime limpets are common throughout the Falun Caverns region.

**Grey Ooze:** A variety of slime limpet that developed an acid which dissolves the calcite skeletons of coral-like creatures that grow in colonies in the caves. Cultivated by gnomes for manufacturing and construction, wild colonies may be found throughout the caverns.

**Green Slime:** This variety of slime limpet flows over rock walls like an amoeba. It senses warmth at a range of 120 feet. Cave-delvers know it as the slime that drops from high ceilings onto unwary victims. Gnomes and kobolds cultivate it as a food source for domestic animals.

**Yellow Mold, Black Pudding:** Cultivated by gnomes for manufacturing and construction. Now appear in wild colonies throughout the cavern.



**Cave Lizard** (as "lizard, giant", D&D® Basic DM Book, p. 32): Raised for food by the gnomes and kobolds.

**Dire Wolves:** Domesticated as mounts for warrior- and noble-class kobolds. Occasionally found as wild predators.

**Hell Hound:** Raised exclusively as mounts for kobold high nobility. Ruling clan may own a pack of ten to twenty such beasts.

**Giant Rats:** Like the gnomes, kobolds raise giant rats as work animals and as pets. Wild giant rats also abound. **Shrieker:** Raised by gnomes and kobolds as an alarm system and food source.

**Giant Fish:** Blind cave varieties provide food for kobolds.

**Purple Worms:** Denizens of lower caverns, they are hunted by kobolds for food and hides. Kobolds trick worms into eating carrion that conceals containers of yellow mold and black puddings.

**Giant Ants:** Raised as draft animals by gnomes, wild colonies of these creatures rule the southeastern part of the Falun Caverns. They occasionally raid the kobold settlements.

**Blind Robber Fly, Bat, Carrion Crawler, Giant Centipede, etc.:** These and other species are found wild in the Falun Caverns.

### Kobolds As a Race

Kobold history is largely unknown. Various scholars argue that kobolds may be an elder race (demi-human like elves and dwarves), or of giantish, goblinoid, non-Prime, or other origin. Similar to gnomes in size, features, and intelligence, kobolds are unlike gnomes, being prolific, aggressive, and fierce, with a strong warrior tradition.

Primitive kobolds are tribal. Small tribes are led by chieftains. Constant inter-tribal quarreling, raiding, and battling prevent primitive kobold cultures from presenting a serious threat to civilized humans and demi-humans.

Periodically a great kobold leader comes along and welds squabbling tribes into nations. Then the kobold cultures may become important factors in human and demi-human history. (See "The Leg-

end of the Shining One," p 47.)

These legendary kobold heroes, with the divine aid of Immortals of the Sphere of Entropy, may rise among their people in times of need, uniting the kobolds against a common enemy or leading a migration into new territories. Most heroic kobold legends center around artifacts of unknown origin, like holy armor and weapons, or gifts from outsiders, or magical items remaining from a forgotten antiquity.

These periods of kobold unity seldom outlast the leader. Succession is always a bitter battle, and kobold empires usually dissolve in a matter of years.

**Culture:** Primitive kobolds are hunter-gatherers of the wilderness cavern habitat, living off wild creatures of that environment (black puddings, giant millipedes, etc.). At more sophisticated levels of civilization, kobolds cultivate subterranean crops (fungi and mold), and domesticate cavern plant and animal life forms, living in cave villages like dwarves and gnomes.

Kobolds are not literate—all culture is

## ADVENTURES

orally transmitted—so kobold civilization is a precarious thing. Some kobolds have been known to learn other written languages and basic arithmetic.

Kobolds see themselves as cruel and ruthless, and they do not consider that evil. Their hard-hearted attitudes toward war, killing, and merciless authoritarian rule are the result of population pressure and warrior traditions, and a religion which ennobles ruthlessness and power as sign of enlightenment.

Kobolds are xenophobic and paranoid. Tradition and experience has taught that all outsiders intend to kill kobolds. Kobolds have a particular antipathy for gnomes. The reasons for this violent mutual hatred are lost in antiquity. Kobolds raid gnomes with self-destructive irrationality, and exterminate gnome settlements whenever possible.

**Relations with Other Humanoid Races:** Kobolds rarely cooperate with others of their own species, let alone with other humanoid races. However, the Hardanger kobolds are currently entering into alliances with a few hill gnoll tribes, providing weapons and tactical support against Whiteheart Valley settlers.

**Relations with Humans:** Humans are considered evil. Kobolds fear and respect human magic. They distrust human promises. Human lowlanders do not intimidate kobolds, who doubt that any humans can match kobolds in subterranean terrain. Human visitors to the mountains must be slain, or others may come. Trade caravans are raided for loot, and to discourage settlement.

**Crafts and Technology:** Primitive tribes use crude leather armor and shields, prefer spears and clubs as weapons, or use plundered arms. Civilized kobold cultures borrow crafts and the full scope of military technology from gnomish and dwarven races.

### **Kobold Social Structure**

There are five kobold social classes. **Nobles:** Two or three powerful families are the ruling class of a typical kobold tribe. Membership is by birth, but successful warrior-class kobolds are often

welcomed into the noble class, creating an unstable and fragile power structure in times of war. Nobles are trained as superior warriors. Weak noble offspring may be accepted into the shaman or wicca classes. Serf- and warrior-class kobolds obey nobles on pain of death.

Nobles are equivalent to "chieftains." See "Kobolds," *D&D® Basic DM Book*, p. 32.

**Wiccans:** In primitive tribes, wiccans are magic users of limited skill. (See *D&D® Masters DM Book*, pp. 21-22). In more stable kobold cultures, wiccans may learn many of the spells known by humans and demi-humans, and employ items like potions, scrolls, and other sophisticated artifacts. Wiccans also engage in the salvage of dwarven and gnomish devices.

**Shamans:** Kobolds worship the Immortals of the Sphere of Entropy. Each tribe has its patron demon. Shamans have exclusive control over the benefits and obligations of service to these demons. The prestige and influence of this clerical class rises and falls with the fluctuating generosity of the patron demon.

**DM Note:** Non-human spellcasters get short-changed in the Master rules (*D&D® Master DM Book*, pages 21-22). This is tolerable for primitive and fourth-rate humanoid menaces, but more civilized non-human cultures may be brighter and more sophisticated than this.

We encourage you to develop your own non-human spellcasters for your own campaigns. Raising the calibre of non-human opposition permits a DM to retain the non-human races as antagonists even while the PCs continue their inevitable rise to higher, more powerful character levels. If it is available, examine the Gazetteer covering the Orcs of Thar as an example of a well-developed humanoid race.

**Warriors:** The Falun Cavern kobolds, like most Hardanger kobold tribes, are of a proud wolf-riding tradition. As soon as a warrior whelp can walk, he is taught to ride and handle the bow, short sword, and spear. Kobold warriors have high morale (Morale: 10), and skill in tactics and maneuver. When led by a noble, they are well-organized and efficient on the attack.

Without noble leaders, they prefer hit-and-run tactics. Though war parties are often accompanied by wiccans and shamans on wolf mounts, the inferior wolfmanship and lack of warrior prestige prevents these spellcasters from being used most effectively, unless under the guidance of exceptional kobold nobles.

Warriors are equivalent to "bodyguards." See "Kobolds," *D&D® Basic DM Book*, p. 32. For warrior mounts, see dire wolves under "Wolf," *D&D Basic DM Book*, p. 39.

**Serfs:** Most kobolds are serfs, toiling to provide for their own needs and the needs of the warrior and noble classes. All serfs are militia-trained, using spear and sling, but they are not permitted to carry these items without the specific permission of a noble. They have poor morale (Morale: 6) unless cornered or defending their lair (Morale: 8). See "Kobolds," *D&D Basic DM Book*, p. 32.

### **The Kobold Settlement in Falun Caverns**

The Falun Caverns kobolds live in three main areas.

1. Forty warrior-class kobolds occupy the ruins of the former Metal Guild, with their mounts nearby. Small, agile, and armored in chain mail of gnomish design, the kobold warriors fight with spear, short sword, and crossbow.

Each rider carries three poisoned quarrels, individually wrapped and sealed. The poison is manufactured from slime limpet (gelatinous cube) secretions, and is potent only for five rounds after it is exposed to air. A wounded victim must save vs. Paralysis, or become paralyzed in 3d6 rounds. The paralysis is the normal type, lasting 2-8 turns unless magically cured.

**Wolf Riders:** NA 40; AC 4; HD 1\*; #AT 1; Damage - by weapon, some poisoned; MV 90' (mounted: 150'); Save F1; ML 8; TT P; XP 19.

**Dire Wolf Mounts:** NA 40; AC 6; HD 4+1; #AT 1 bite; Damage - 2-8; MV 150'; Save F2; ML 8; TT nil; XP 125.

2. The serf-class kobolds (160 individuals) occupy the gnome ruins and kobold-style huts built of loose limestone in the vicinity of the former Stone Guild.

**Kobold serfs:** NA 160; AC 7; HD 1/2; #AT 1; Damage - by weapon; MV 90'; Save NM; ML 6/8; TT P; XP 5.

Serfs are armed with spears (1d6-1 for melee damage for low strength, minimum damage = 1 point), sling, leather and shield. Serfs only fight when attacked, or when under command of a noble.

3. The forty noble-, shaman-, and wicca-class kobolds occupy the upper levels of the former Worm Ranch.

**Noble Guard:** NA 8; AC 4; HD 2; #AT 1; Damage - by weapon; MV 90' (mounted: 150'); Save F2; ML 11; TT P; XP 25.

**Worg (Dire Wolf) Mounts:** NA 8; AC 6; HD 4+1; #AT 1 bite; Damage - 2-8; MV 150'; Save F2; ML 8; TT nil; XP 125.

**Clan Chief and Sons:** NA 5; AC 4; HD 2; #AT 1; Damage - by weapon; MV 90' (mounted: 150'); Save F2; ML 11; TT P; XP 25.

**Hellhound Mounts:** NA 5; AC 4; HD 3\*\*; #AT 1 bite or 1 breath; Damage - 1-6 or special; MV 120'; Save F3; ML 9; TT C; XP 65.

**Noble Households:** NA 20 (as serfs).

**Kobold wiccans:** 1 Level 3, 1 Level 5. NA 2; AC 9; HD 3/5\* (4-sided dice); #AT 1; Damage - 1-3 dagger; MV 90'; Save M3/5; ML 6; TT P; XP 75/400.

**Kobold shamans:** 4 Level 3, 1 Level 6. NA 5; AC 4; HD 3/6\*\* (six-sided dice); #AT 1; Damage - 1-6 mace; MV 90'; Save C3/6; ML 10; TT P; XP 100/725.

Each shaman carries a staff blessed by the clan's patron demon Hircismus. The staff can be used to *charm monster* once a day as the spell, except it only affects one creature of 3HD or less. The shamans *charm* cave creatures as available—giant



ants, giant spiders, robber flies, giant lizards, giant beetles, carrion crawlers, and so on—and send them against the clan's enemies. To activate the staff, Hircismus must be invoked.

#### **Kobold Defense Tactics**

Though not particularly anticipating a human invasion, the martially-aggressive kobolds are constantly prepared to defend their territory from all attackers. Here are some of their routine precautions and tactics in defense of Falun Caverns.

Patrols of five kobold wolf-riders regularly travel on the surface near the cave entrance, alert for intruders. They supplement community food stores by casual hunting. In clear weather, kobolds keep watch from high mountain stations that permit observation of any party approaching from the lowlands.

Patrols avoid a direct approach to the cave entrance in daylight. If trackers are suspected, patrols go to an alternate opening, leading into wild caverns four miles from the main entrance, confident of losing pursuers in the passages.

Two kobold sentries watch the main entrance at all times. If intruders are discovered, one sentry brings the alarm to the warriors, while the other secretly follows the intruders to note divergences into side passages. The serf militia deploys along the main corridor and

guards other approaches to the noble camp. Warrior brigades are sent out along the flank to engage intruders and delay the interlopers' advance.

The kobolds' overall strategy begins by denying intruders an approach to the main corridor. The front line consists of the numerous but ill-trained serf militia. The best warrior brigades range on the flanks, and nobles are held in reserve to exploit tactical advantages.

Once intruders are committed to a path, flankers circle around to take the flank and rear. If necessary, the kobolds will withdraw from the settlement and force intruders to fight their way into it.

The basic principle of kobold underground strategy is to avoid major engagements and casualties, because the terrain favors the kobolds' superior knowledge. There is almost unlimited territory to withdraw into. Certain cave areas are known to be risky for withdrawal (i.e. kobolds avoid withdrawing into the ant colonies) but intruders unfamiliar with these risks cannot plan for them.

#### **Specific Unit Tactics**

1. Engage with missile weapons from cover at the narrow end of a long passage. Force intruders to approach through missile fire, then withdraw.

2. Charge, melee briefly, then retreat through a squeeze too small for most human intruders.

## ADVENTURES

3. Engage and withdraw repeatedly, leading intruders away from the settlement area, and leaving the intruders' rear and flanks open for attack.

4. Withdraw through pools and underwater passages. (Kobolds have thick skins and are resistant to the cold.)

5. Attack light sources. Shamans armed with *continual light/darkness* bombs toss them on the cave floor. (Spell is cast on a rock and tossed near the party to engulf them in darkness. The PCs should have a devil of a time finding the right rock on a floor of similar rocks!)

6. Drive wild beasts toward intruders. Giant beetles and ants are most useful.

### FALUN CAVERNS SCENARIO SUGGESTIONS

• **Rescue:** Millen the Wise, a prominent local sage and scholar, took off looking for gnome ruins. Millen has been missing for three weeks. Runecasts say he is still alive. Notes suggest the location of the Falun Caverns as the scholar's original destination. Among the notes he left behind is a copy of the player map.

• **Loot:** The PCs are offered the player map for a price they can't refuse. Since gnome artifacts are said to be very valuable, the profits could be fabulous. The seller invites the PCs to use spells to insure that the map is genuine. The seller can't help that it can't be translated easily; it's still a bargain.

• **Reconnaissance in Force:** Vigfus the Red, noted dogman hunter, discovers the ancient remains of gnome adventurers frozen in a snow cave high in the Hardangers. Among their possessions is the gnomish map. Vigfus hires the PCs to help him find the caverns and earn the bounty on kobolds offered by the Town Council of Castellán.

### LEGEND OF THE SHINING ONE

The "Shining One" and the rise of the Hardanger Kobold Nations is an obvious theme for a Northern Reaches campaign. The background can be worked into less extensive games where kobolds are an

important factor, such as the quick scenarios suggested above. Full development of the Rise of the Kobolds campaign is left for the dedicated DM.

A powerful theme in kobold oral history is the ancestral hero known as the "Shining One." This legendary hero wears a brilliantly radiant suit of kobold-sized plate armor, with numerous magical properties; the suit itself crafted by kobold masters of the Golden Age.

This hero was betrayed by a friend at the height of his accomplishments. The mortally-wounded hero was borne to the deeps by demon servants, but he promised to come again to aid the kobold peoples in their time of greatest need. "Preserve the weapons of your ancestors," he said. "The dog shall have his day."

The ancient hero's magical suit of plate has been recovered from a subterranean vault by a kobold chieftain, Psa'gh, questing on the Path of Immortality in the Sphere of Entropy. Before setting out, Psa'gh's companion, Thra'gh (a powerful kobold shaman), summoned a demon and asked how they might best avenge the injuries and insults inflicted upon the kobold races by humans and demihumans. The demon directed Psa'gh and Thra'gh to the suit, and told them they would come to power among the kobolds, leading them to victory over the kobolds' enemies.

That was forty years ago. During these decades, Psa'gh and Thra'gh have indeed come to power, uniting hundreds of smaller kobold clans under their rule. Now they have begun to move against the outside world, seeking a war of revenge against the kobolds' ancient enemies. Beginning with small raids on Northland settlers, Psa'gh hopes to goad the human forces into foolish military operations in terrain that favors kobolds.

Taking the long view, as one blessed with the longevity effect of the Suit of Silver, Psa'gh expects to expand into the lowlands within twenty years or so. Unfortunately, Thra'gh has not benefited from the Suit of Silver's magical extension of youth, and he is growing impatient as he grows older. He also grows a little jealous of Psa'gh, who has all the

credit. Herein lies the possible repetition of the original betrayal of the previous hero.

The rise of Psa'gh explains the sudden increase of kobold activity in the Northern Reaches. Neither Psa'gh nor Thra'gh appear directly in Falun Cavern scenarios, but both are national heroes and symbols of rising kobold power. The many tales of their heroic exploits are on the lips of kobolds of all classes, and "By the teeth of Psa'gh," "In Thra'gh's name," "Light of the Shining One upon you" are common oaths and greetings among the kobolds of Falun Cavern.

### CARDBOARD CUT-OUTS (OR, TAB A AND SLOT B)

#### Using the Fold-Out Map and 3-D Buildings

The reverse of the large Northern Reaches fold-out map bears the layout of "The Jarl's Village and Stead," which represents a typical Northern Reaches homestead. In conjunction with the 3-D buildings, this layout is used when playing the scenarios of "The Defense of Otkel's Stead," and "The Jarl's Hall." It may also be adapted for use with home-grown scenarios.

The four full-color inner covers are





printed with designs to be cut out and glued together to form 3-D buildings for the homestead layout. Directions for assembly of the village components are printed directly on the inner covers. When assembled, these buildings should be placed over the floor plans drawn on the layout. During a game, the 3-D buildings may be used to conceal counters or figures of characters within the structures. (This can give players a nasty surprise when they discover fifty armed warriors hiding in a little shed!)

The village and homestead layout uses a scale of approximately 1.5":10'. This is roughly equivalent to 15mm scale. Metal figures in 25mm scale may be used to indicate positions during scenarios, but the proportions will be misleading. For a more accurate appearance, use the cut-out counters provided on the four full-color inner covers, or use 15mm metal figures.

### Key to Village and Stead Floorplans

The descriptions below apply to both scenarios. The scenarios include other details specific to their settings.

**Gate Tower:** The first floor of the gate tower is hard-packed earth, which gets very muddy in wet weather. The upper floor is a plank platform surrounded by a chest-high plank wall to provide guards with cover from missiles.

**Huts:** The hut walls are made of planks or wattle-and-daub. The roof is made of thatch. Sleeping benches are wooden platforms raised two feet above the straw-covered, hard-packed earth floor. Furs and wool blankets provide cushioning and warmth. A fire pit warms the sleeping bench. The only other furniture is a crude trestle table and three short wooden stools.

**Longhouses:** The walls are made of planks; the roof is thatched. Two long sleeping benches face each other, with a row of fire hearths down the center. Two rows of timber pillars support the high roof. Opposite the doors is a raised platform, the place of honor where the head of the hall sits on the High Seat, sur-

rounded by kin, loyal followers, and special guests. Moveable screens may be placed across the hall to give the head of the household some privacy for conversation or sleep.

**Large Longhouse:** This comes in two pieces: the main hall, and the private quarters.

The main hall is similar to the smaller longhouse, except a large table is provided for the master of the hall and his favorites.

The private quarters are walled off from the main hall, and the passage partitioned by a curtain. Just inside the passage are sleeping benches for servants, guards, or other close associates of the head of the house.

Through a second curtain are the private quarters of the household head. The room is furnished with a large, comfortable pallet of straw covered with furs and thick wool blankets. The household head keeps his prized possessions in chests and trunks stashed along the wall.

## The Defense of Otkel's Stead

### Scenario Summary

A farmer and his family face raiding monsters. The PCs and neighboring farmers gather to defend the farm and drive off the raiders.

### The Setting

On the inside cover is a general map of Fjallese Valley, where Otkel and his neighbors have made their homes. The DM can locate this valley in any of the northern nations, but placing it on Vestland's frontier or in the Jarldoms is most appropriate.

Use the printed map for surrounding terrain or design your own locale. The layout of the farmstead itself uses the foldout map and the 3-D cardboard buildings. For this scenario, they are designated as follows:

**The Large Longhouse:** This is the family house. Otkel Arnulfson's prosperous frontier stead has made him a wealthy man. He and his wife enjoy the private

room at the back of the longhouse. Their elderly parents, young children, and servants share the outer sleeping room.

Otkel's older children normally have the run of the great hall. At harvest time, however, Otkel hires a few extra laborers, who sleep in the great hall.

**Longhouses:** For this scenario, use these as barns for livestock and storage. Ignore the sleeping benches, favored bench, and high seat on the map.

The north barn is used for storage of grain, animal fodder, and farming tools. The south barn get different uses through the cycle of seasons. In summer the barn is usually empty. During the late spring, the sheep are sheared here. In late fall, winter, and early spring the livestock are sheltered here, sheep, cattle, and horses.

Otkel owns four fine horses for riding, and many sheep and cows. He keeps six oxen for plowing and drawing the two carts. The carts are used as needed around the farm, and to bring grain and vegetables to the market in the nearest village. When not in use, the carts are stored in the south barn.

**Huts and Sheds:** Two huts are turned over for the use of the farm laborers. If the scenario is set in Ostland, the laborers are thralls. In Vestland and Soderfjord, laborers are freemen. One other hut is reserved as a guest house. One hut has been made into a sauna—every member of Otkel's household (even the dogs) really likes the sauna, which is the only way to chase out the bone-deep chill of winter. Two sheds shelter the dogs, and the other is used to store firewood.

### The Defenders of Otkel's Stead

**Otkel Arnulfson:** *F3, enchanted heirloom broadsword +2, spear, bow, chain +1, shield. Courageous 17, Dogmatic 15.* The head of the household, Otkel is in his late 40s. He has worked many long and hard years on this farmstead, and his efforts have made him prosperous.

**Bera Eyvindsdottir:** *L2 wise woman.* (See page 61 for details about wise women as an NPC class.) *Trusting 5, Honest 5.* Otkel's wife. Bera conceals her knowledge of the Power, knowing magic users

## ADVENTURES

are viewed with suspicion.

**Arnulf Sorenson:** *F2, sword, spear, chain, shield. Courageous 18, Cautious 3.* Otkel's aging father. Arnulf was a sea-rover in his youth. Now over 70, he is becoming a bit senile but still wants to die in combat.

**Helga Sigvatsdottir:** *Courageous 7.* Arnulf's wife. She knows he's not as sharp as once he was, and she fears for him. She is known throughout the region for the quality of her weaving.

**Aud Otkelsdottir:** *L1 wise woman. Trusting 15.* The oldest of Otkel's children (age 22). Aud has a touch of the Sight, like her mom. Aud has learned what her mother can teach her about the use of magic, and also keeps her ability secret. This privacy is one reason she has not married, in spite of her trusting nature.

**Erling Otkelson:** *F2, sword, javelin, spear, chain, shield. Courageous 15.* Otkel's oldest son (age 18) dreams of leading the life of a sea-rover, having listened to his grandfather's tales. He has agreed to wait until his twentieth birthday to go to sea.

**Sigmund Otkelson:** *NM, sword, javelin, spear, chain, shield. Courageous 11.* At 15, Sigmund cannot understand his brother's wild desires. Sigmund is a hard worker in love with the land, satisfied with a farmer's life.

**Helga Otkelsdottir:** *NM, spear, shield. Cautious 7.* Non-identical twin to Thorunn, both Helga and Thorunn are gawky 13-year-olds.

**Thorunn Otkelsdottir:** *F1, sword, bow, chain, shield. Reverent 14.* Thorunn takes her name-allegiance to Thor seriously, and has the makings of a warrior woman. Her neighbor's son, Isleif Njalson, woos her; they hope to marry on Thorunn's Heyday birthday.

**Rolf Otkelson:** *NM -2, spear. Courageous 13, Cautious 3.* Rolf is precociously bright for his 11 years. He knows every stream and wooded nook in the valley.

**Hlif, Gyda, and Herdis Otkelsdottir:** *NM -2, no weapons.* The youngest children of the household, ages 2 to 8 years old.

### Steinthorson Family

These individuals live in Hut #1.

**Ljotolf Steinthorson:** *NM, bow, spear, leather armor, shield. Courageous 10, Loyal 15.* Laborer. A quiet, strong man in his 30s, unremarkable.

**Thora Bjornsdottir:** *NM, no weapons. Courageous 5.* Laborer. Thora works hard, often watching over the young children in the main household.

**The Steinthorson Children:** *NM -2, no weapons.* Four youngsters under 10.

### Knutson Brothers

These two laborers live in Hut #2. Otkel was locally criticized for taking a chance on these two, who look unsavory. They are just ordinary folk who work an honest day for an honest meal.

**Knut Knutson:** *NM, spear, shield. Loyal 12.* Laborer. A bull of a man, Knut looks intimidating but unintelligent. Both assumptions are incorrect.

**Ivar Knutson:** *NM, spear, shield. Laborer. Loyal 8, Energetic 6.*

### The Dogs

The dogs of the household are encouraged to sleep in Sheds #1 and 2. However, when not actually working, they wander freely around their territory, up the dales exploring with Rolf or underfoot in the houses.

**The Hounds:** Belmond, Bowler, Bashful, Greatheart, Wolf, Anskar, and Frog. Belmond is a gallant old hound, devoted to Otkel, and his brood are just as noble. The household uses these dogs for hunting. Greatheart is especially attached to Erling Otkelson, but all respond to Otkel and the older sons and daughters. On command, they attack ferociously and without regard for personal safety. *Speak with animal* would make them formidable skirmishers.

**Hounds:** *NA 2-12; AC 7; HD 2; #AT 1; Dam 1-6; MV 120'; Save F1; ML 12; TT Nil; XP 25.*

**The Sheep Dogs:** Ingolf, Hrefna, Blue-Nose, and Witch. These dogs are smart,

able to follow orders. They're positively brilliant at rounding up sheep. They prudently run away from nasty beasts. *Speak with animal* would make them superb scouts.

**Sheep Dogs:** *NA 2-12; AC 7; HD 1; #AT 1; Dam 1-4; MV 180'; Save F3; ML 7; TT Nil; XP 20.*

In the North, neighbors rely on each other's assistance in times of trouble. The following neighbors will come to the aid of Otkel's Stead if summoned.

### Njal's Stead

**Njal Ottarson:** *F2, spear +1, sword, chain, shield. Cautious 14.* Head of his stead, Njal is younger than Otkel but otherwise much like him in attitude.

**Isleif Njalson:** *F1, ax, javelin, chain, shield. Loyal 15, Courageous 12.* Njal's eldest son. He is Thorunn Otkelsdottir's sweetheart, and would race to protect her and her kin.

**Eystein Eldgrim:** *F3, bow, sword. Cautious 16, Honest 12.* Eystein works for Njal, but he's secretly an outlaw.

### Skamkel's Stead

**Gilli Skamkelson:** *F1, spear, sword, leather, shield. Cautious 7.* Second son of Skamkel. Skamkel himself cannot fight because of a crippled right leg.

**Hord the Bitter:** *NM, bow and spear. Trusting 6, Forgiving 5.* A laborer for Skamkel, Hord resents every order he receives, but he does his best anyway.

### Hoskuld's Stead

**Hoskuld Hemmingson:** *F1, bow, spear, leather, shield. Peaceful 14, Generous 16.* Head of his household.

**Gudrun Erlendson:** *NM, spear, leather, shield. Courageous 12.* Laborer.

### Lodin's Stead

**Brynhild Hrodnysdottir:** *F2, sword, spear, javelin, chain, shield. Courageous 14, Energetic 18.* Eldest daughter of Lodin (by adoption), Brynhild is a fighter who has seen action in her jarl's guard.

**Halldis Halfliefson:** NM, spear and javelin. Cautious 15, Trusting 7. Household servant and laborer.

### The Raiding Monsters —

Use one of the three groups below, or design your own raiders. The trolls are individually the toughest, but they are stupid, overconfident, and relatively few in number. The gnolls have no magical abilities, but they are more numerous, cautious, and intelligent. The kobolds are the most dangerous, being numerous, well-disciplined, and supported by magic.

### Sleek-Skin's Troll Band —

Trolls are found in large numbers only in northwest Vestland. If the troll raiders are used, Otkel's Stead should be located in a borderland domain of the Trollheim hills.

These young troll raiders are on a mission of revenge. Months past, a state-funded expedition cut through the troll-held moorlands, destroying three villages and taking several troll heads as trophies.

Sleek-Skin, leading the band, seeks to avenge the killing of his brother. He has promised to take five heads for his brother's one, and his fellow raiders have sworn similar oaths.

The trolls have two very simple objectives: kill a lot of humans and destroy as many human settlements as they can. The motive of revenge, reinforced by solemn oaths, makes them bolder than typical trolls. They are not going to be put off by the local farmers. The trolls are not interested in treasure or magical items, but they are interested in sheep and cattle. Trolls can travel for several days on a single meal, but that meal has to be a feast.

These trolls have never dealt with experienced adventurers, and they may be intimidated by shrewd tactics, skilled use of fire and acid, or by magical firepower. The death of one troll will increase their desire for revenge. One more death and the trolls will start to lose heart. After the

fourth troll dies, make regular morale checks to see which trolls decide they've had enough.

**Trolls** (Sysop, Yump-Leg, Mak-Ditz, Ongous, Pertgart, Hop-Hatcher, Fatty, Rejigger, Oak-Head): NA 1-8; AC 4; HD 6+3\*; #AT: 2 claws, 1 bite; Dam 1-6/1-6/1-10; MV 120'; Save F6; ML 12(10, if injured by fire or acid); TTD; XP 650. Special Ability: regenerate damage in third round after wounded; regenerate 3 hit points per round. Damage from fire or acid does not regenerate.

**Sleek-Skin:** troll raider leader. Same as above, but maximum hit points and morale 12, regardless of injuries.

### Shadrak's Gnoll Raiders —

The gnoll raiders are more numerous and intelligent than trolls, but lack the trolls' durability. If gnoll raiders are used, Otkel's Stead should be located in a domain bordering the hills of Gnollheim in southeastern Soderfjord.

The BlackHair Gnolls raid frontier farms for several reasons. First, they steal sheep and cattle which they later sell to unscrupulous human stocktraders. Second, they steal human possessions to use or sell. Third, they treasure magical weapons and devices, and can get them no other way. Fourth, gnoll warriors gain prestige by defeating opponents in battle, and humans are considered particularly fearsome opponents.

This band of forty gnolls is led by Shadrak, an old and experienced raider. Shadrak and two comrades scouted Otkel's Stead the previous year, and noticed that even a large band could approach under cover of darkness without risking discovery. Shadrak also noted that neighbors could not be summoned quickly.

Shadrak's plan is to sneak up at night, surprise the inhabitants, massacre them, and be gone before sunrise. Even if he fails to surprise the household, he feels he can burn them out and loot the stead in no more than 24 hours.

Shadrak plans to send three groups of

gnolls to sneak into the stead. One group is to overcome any guard and open the gate. The next is to find and kill the horses. (Gnolls greatly fear humans on horseback, who can fight and pursue gnolls very effectively.) The last group is to seal the doors to the longhouse while setting the roof on fire. The burning roof is the signal for the rest of the gnolls to storm the walls.

If Shadrak's surprise plan fails, he'll try to sucker the defenders into coming out to attack him. If that fails, he intends to set fire to the thatch roofs with fire arrows on the following night, then storm the walls in the confusion.

The PCs may confound Shadrak's plan by being at the stead when Shadrak attacks, or they may have been tracking Shadrak all along. They may be visiting a neighboring farm and be summoned to aid in the defense.

Shadrak's gnolls are divided into four war bands, each led by a Brave or by Shadrak himself. As long as the leader is with the band, the band fights as though it had the leader's morale.

**Gnolls:** NA 36; AC 5; HD 2; #AT 1; Dam by weapon; MV 90'; Save F2; ML 8; TT P; XP 20.

**Gnoll Brave:** NA 3; AC 3; HD 2+2; #AT 1; Dam by weapon; MV 90'; Save F3; ML 10; TT Q; XP 30.

**Shadrak, Gnoll Chief:** NA 1; AC 5; HD 3; #AT 1; Dam by weapon; MV 90'; Save F3; ML 11; TT R; XP 20.

Gnolls rely on the spear in melee, but their preferred weapon is the bow. Gnolls' tough skin gives them a natural AC 7 without armor and they wear leather armor. They get +1 for damage with weapons for their superior strength. The damage bonus is only for melee attacks.

### The Kobold Guerilla Raiders —

This is a carefully planned military operation intended to draw a major defending force into the valley. By massacring one stead and terrorizing the others, the kobolds expect to sucker a militia or mer-

## ADVENTURES

cenary force into the hills after them.

Fifteen kobolds on foot stage what seems to be a poorly organized attack on Otkel's Stead. Otkel sends for help.

Ten worg riders lie in wait along the road near Hoskuld's Stead and ambush the neighbors coming to reinforce Otkel. Presumably the kobolds can drive them off, and may wipe them out. Then the ten worg riders proceed to Hoskuld's, then Lodin's Stead, terrorizing the settlers and attacking targets of opportunity. When finished with Lodin's Stead, or if threatened by a larger force, they ride north into the hills. (If the PCs become involved in the defense of Hoskuld's or Lodin's steads, improvise on the stead's layout, using Otkel's as a model.)

Meanwhile, the siege of Otkel's Stead begins in earnest. First, the thatch roofs are burned with fire arrows. Each night, kobolds attempt several attacks or surreptitious entries into the stead. Mounted kobolds pursue and engage anyone trying to escape. By the time Otkel's Stead falls, the kobolds will have heard from the worg riders. According to the reports, the kobolds will either continue attacking other steads or, if threatened by a large force, they will withdraw into the hills.

The kobold infantry and worg cavalry are well-disciplined and organized. Kobolds know it is death to go toe-to-toe with human fighters. Instead, kobolds depend on ambushes and hit-and-run skirmishes. They prefer using crossbows, to keep their distance. They try to pick out the weakest individual, distracting others with feints and missile fire. Kobolds are patient and methodical, and follow orders effectively.

Each fighting unit has ten kobolds, including a magic user and a cleric for magical support. A common tactic is to concentrate magical attacks on one victim while distracting other foes. The wolf-riding cavalry avoids melee, preferring to hit and run. But if an opportunity to surround a smaller party arises, the cavalry charges. Individuals then dismount and melee. Dire wolves fight in melee alongside their dismounted riders.

The captain in charge of this operation is shrewd. If he discovers that his forces

face veteran adventurers — particularly skilled magic users— he'll withdraw into the hills, sacrificing a decoy unit if necessary to permit the main force to escape.

**Wolf Riders:** Kobold warriors go armored in mail of gnomish design. They fight with spear, short sword, and crossbow. Each rider carries three poisoned quarrels, individually wrapped. The poison is manufactured from slime limpet (gelatinous cube) secretions, and is potent only for five rounds after it is exposed to air. A wounded victim must save vs. Paralysis, or become paralyzed in 3d6 rounds. The paralysis is the normal type (lasting 2-8 turns unless magically cured).

**Wolf-Riders:** NA 20; AC 4; HD 1\*; #AT 1; Damage - by weapon, some poisoned; MV 90' (mounted: 150'); Save F1; ML 8; TT P; XP 19.

**Dire Wolf Mounts:** NA 20; AC 6; HD 4+1; #AT 1 bite; Damage - 2-8; MV 150'; Save F2; ML 8; TT nil; XP 125.

**Spellcasters:** This includes both clerics and magic users.

**Kobold clerics:** One L2 cleric for each unit of ten kobolds. NA 2; AC 4; HD 1; #AT 1; Damage - 1-6 mace; MV 90'; Save C2; ML 8; TT P; XP 25. Each shaman carries a magical staff blessed by the clan's patron demon Hircismus. The staff can *charm monster* once per day as per the spell, except it only affects one creature of 3HD or less. To activate the staff, Hircismus must be invoked.

**Kobold magic users:** One L2 magic user assigned to each unit of ten kobolds. NA 2; AC 9; HD 2\*; #AT 1; Damage - 1-3 dagger; MV 90'; Save M2; ML 6; TT P; XP 35.

**Dire Wolf Mounts:** NA 4; AC 6; HD 4+1; #AT 1 bite; Damage - 2-8; MV 150'; Save F2; ML 8; TT nil; XP 125.

**Command Group:** This includes the nobles and the chiefs.

**Noble Guard:** NA 2; AC 4; HD 2; #AT 1; Damage - by weapon; MV 90' (mounted: 150'); Save F2; ML 11; TT P; XP 25. Equipped as warriors, but without crossbow.

**Dire Wolf Mounts:** NA 2; AC 6; HD 4+1; #AT 1 bite; Damage - 2-8; MV 150'; Save F2; ML 8; TT nil; XP 125.

**Noble Chief:** NA 1; AC 4; HD 2; #AT 1; Damage - by weapon; MV 90' (mounted: 150'); Save F2; ML 11; TT P; XP 25. Equipped as warriors, but without crossbow.

**Hellhound Mount:** NA 1; AC 4; HD 3\*\*; #AT 1 bite or 1 breath; Damage - 1-6 or special; MV 120'; Save F3; ML 9; TT C; XP 65.

### Staging the Scenario

PCs can be introduced into this scenario in one of several possible ways.

- Journeying through the hills to some other destination, the PCs accept the hospitality of a farmer in Fjallesen Valley. Thus, the PCs might be at Otkel's when the raiders are discovered, or they may be at a neighbor's stead when a breathless boy rides up screaming, "Trolls! Trolls! At the farm! Hurry!" The rules of hospitality demand that guests aid their host.
- While journeying through the valley, the PCs notice black smoke coming from a hollow up in the hills. A Nature Lore or Know Terrain skill check indicates that only a housefire would cause that sort of smoke. Lawful adventurers should feel obligated to investigate.
- The PCs have been hired by a jarl as mercenaries, looking for outlaws and monsters. The PCs come across the trail of a large group of creatures. Skill checks reveal that the creatures are outfitted for war. The PCs follow the raiders who are attacking Otkel's Stead.

### Tactics and Resources

Otkel is brave but unshrewd. He will insist on leading the defense as long as his tactics seem effective. Otkel has the typical



Northman distrust and ignorance of magic, and no gift for improvisation with its resources. Aud might be able to persuade Otkel to follow a PC's counsel, given the chance. Otkel's tactics are straightforward:

1. Send to other steads for help. Younger sons and daughters are sent out on horseback.
2. Gather livestock in barns. Livestock is wealth, and Otkel will not lose it without a fight.
3. Organize a scouting party to get a good look at the opposition. Otkel, his father Arnulf, eldest son Erling, and one of the laborers go scout the enemy. They may stumble into ambush or combat. Too brave to withdraw, they are apt to lose at least one victim.
4. Defend the walls of the stead. If neighbors have arrived, improvise a defense with fighters distributed around the walls armed with javelin, bow, and spear. If no reinforcements are available, a successful defense is unlikely unless the PCs cover the walls with magic.
5. If driven from the walls, retreat to

the great hall and defend from there. If the raiders are trolls, there's no danger of fire attack, but if gnolls or kobolds are the raiders, the great hall is likely to be burned.

The PCs can bring some variety and more effective techniques to this linear sequence of tactics.

1. *Fire, acid, and cold steel:* Otkel hasn't fought trolls before, and doesn't know their weaknesses. He finds it hard to imagine that fighting with a burning torch is more effective than using the family heirloom, an enchanted longsword.

2. *The dogs:* Clerics with the *Speak with animal* spell can use the swift dogs to scout and skirmish with the raiders. The courageous dogs can draw off some raiders or disorder their attacks.

3. *Aud and Bera:* PCs may discover rune markings on the carved family pillars and connect them with Aud and Bera. Alternatively, when the PCs demonstrate their use of magic, the wise women may reveal their powers to the PCs and offer to

coordinate their efforts. Otherwise, Aud and Bera will try to do what they can in secret. Neither one has experience as an adventurer or warrior, so they have little gift for tactics.

4. *Magic:* This is the PCs' greatest resource. The raiders are generally magic-poor. The locals don't know much about magic, and the PCs' magical abilities and tactics will assist them greatly in handling the raiders.

Finally, a cheap trick for the DM that can enhance the fun: Buy a 99¢ bag of plastic barnyard animals at a toy store and let them "wander around" in the barn or outside the stead. Players will quickly come up with bad ideas about using the livestock as shock troops, and Otkel will scream bloody murder if the raiders kill or steal these treasures.

## The Jarl's Hall

### Scenario Summary

The PCs visit a well-known aging jarl to discover the reason for his failing judge-

## ADVENTURES

ment. If the jarl has fallen under the influence of some evil power, the PCs must search it out and deal with it.

"He was a great jarl, with all a Northlander's virtues. Now his neighbors speak openly of his disgrace. He outlawed his two eldest, and fawns on the least—a sneaking little worm, by all accounts, and a silk-robed witch-man, they say..."

"Eh-ehm..." Saru cleared his throat.

"Eh? Oh, no offense, old friend." Helfdan waved his meaty paw in dismissal. "Not all spellcasters are in league with the dead demons of the Queen of Hel—or so you've told me."

"When last I saw him, three years past, Harek Hard-Sailer was a venerable and respected jarl," Onund observed quietly. "Honored he was, head of the Vastergard clan, and powerful even in his old age. It is hard to imagine him grown a fool."

"Well, I'm not looking forward to meeting those berserkers he's taken as bodyguards," Dwalinn said. "Not even house-trained, I'll bet."

### The Setting

Vastergard is in the Soderfjord Jarldoms. The clan seat of Rollag lies in the heart of the fertile farmlands of the Vastergard domain. Several roads approach the clanhall, passing through small farm villages in Bergholm, and from fishing villages along the coast.

The Great Hall itself occupies a low hill overlooking a modest farming village of 500 inhabitants. For the layout of the Great Hall and associated buildings, use the foldout map and 3-D cardboard buildings, with the buildings being used as described, below.

The Large Longhouse is the residence hall of Harek Hard-Sailer the jarl, his wife, his youngest son, his servants (including Flosi the Fox) and berserkers.

One Longhouse is designated as the residence of Harek's Personal Guard, the noble warriors of the Vastergard clan who serve and protect the jarl and his stead.

The other Longhouse is the residence of the family of Kalf the Dueller, younger brother of Harek, and steadmaster in the

service of the jarl. Various skilled, privileged servants of the jarl's household live here, and honored guests are put up in this building.

Of the huts, the one farthest from the gate is home to two families of laborers. The other hut is the guest house for visitors of lower class and reputation. The shed between these huts provides storage for firewood and tools.

One of the huts closer to the gate houses the family of the royal stablekeeper. The shed nearest the stablekeeper's hut is the royal stable, where two of the jarl's favorite horses are kept. The shed opposite is a stable for the horses of honored guests. The horses of Kalf's family, of the berserkers and Personal Guard, and of other well-to-do stead inhabitants are housed in a larger stable in the village below. The other hut nearest the gate is the Shrine of Thor, and residence of Harek's two Thor priests.

### Personalities

#### Residents of the Great Hall

**Harek Hard-Sailer:** F12. Reverent 17, Dogmatic 20, Peaceful 3, Trusting 5. His possessions include several Vastergard heirlooms: two javelins +3, the Hammer of Justice (a hammer +2 with spell turning ability as the ring), and Valdahelm, the Helm of Lordship (see below).

Never noted for his judgement or wisdom, Harek has nonetheless been an effective ruler. He is tough and tenacious, able to make plans and policies work even under the worst conditions. His hard-headed, assertive self-confidence, and his forty years as a successful leader inspire trust and loyalty.

However, the jarl's recent actions have tarnished his reputation as an effective ruler. He has outlawed and banished his respected elder sons, made his youngest son Hoskuld a favorite, and given preference to the berserkers over the older, respected warriors in his Personal Guard. Even so, the subtle effects of Flosi the Fox's magical influence over Harek have yet to affect the overall prosperity of the clan.

**Gjaflaug Hjaltisdottir,** wise woman L2.

(See the discussion of wise women as an NPC class, page 61.) Generous 7, Honest 5. Gjaflaug keeps her magical powers secret. Only Flosi and Hoskuld know of her abilities, although her daughter Erika suspects. The only physical evidence of her craft is the collection of runestones used with the *interpret runes* spell. The stones are hidden behind a plank near her bed in Harek's private sleeping quarters.

Gjaflaug is Harek's second wife, and Hoskuld is her only son by Harek. Gjaflaug hopes to bring Hoskuld to power and has connived with Flosi to discredit Harek's two elder sons, Atli and Hogni, borne by Harek's first wife. Gjaflaug has never shown more than passing interest in her daughter Erika, and believes her to be loyal but dull.

**Hoskuld Harekson:** C4, publicly claiming to be a follower of Odin, secretly a follower of the Queen of Hel. Energetic 5, Reverent 4, Honest 2. Hoskuld styles himself a black wizard and necromancer, but being entirely self-taught, he's strictly bush league as a spellcaster.

Hoskuld was inducted into the cult of Hel by a C9 Hel cult member who thought a blue-blooded cultist might be a political asset in the future. Hoskuld dresses in black robes like a necromantic magic user, but everyone in Harek's Hall knows his skills and spells are clerical in nature.

**DM Note:** Hoskuld's abilities and his connection with the Hel cult are only minor elements of this scenario. Use them as red herrings to draw attention away from Flosi and the charmed Harek, if the PCs prove so gullible. Hoskuld's main function is as a foil and figurehead for Flosi's machinations.

**Erika:** NM, daughter of Harek and Gjaflaug. Energetic 6. Erika is a quiet, plain child of twelve years. She is a dreamer, spending hours in make-believe play with her dolls. Her only friend is Skapti the Skald, who entertains her with tales of gods and heroes. Erika has an over-developed imagination and sense of the dramatic. She is apt to exaggerate and fantasize extravagantly, but she may become a useful informant and ally for PCs.

She's always present for formal family gatherings and official clan audiences, because she is expected to be, but she stays in the background with the servants and avoids attracting attention. She has no interest in the activities of her elders, and only wishes to be left alone.

Nonetheless, she is a clever, observant girl. She suspects her brother is a secret conspirator of some sort. She has followed him sneaking off to the fields on moonless nights to meet with his cult associates, though she has no idea where they ride to after they meet.

Erika suspects her mother of practicing runecraft, as she's secretly observed Gjalgaug consulting her runestones. There is little in the household she has not seen—but she attaches little importance to any of it.

**Flosi the Fox:** *C9, a Loki priest masquerading as an elderly servant and advisor to Harek. Trusting 4, Honest 2.* Flosi only joined Harek's service five years ago, but has become the jarl's most trusted advisor. He earned his nickname from Harek for being such a shrewd counselor.

To appearances, Flosi is bald, grey-whiskered, and limps slowly and painfully with the use of a cane. In fact, Flosi is in his late thirties. His limp and painful gait are feigned and, unobserved, he can move with agility.

Although Flosi conspires with Hoskuld, they are never seen speaking together. A pet rat carries messages between them, detailed under "Revealing Flosi's Role."

**Jarrett Weldon:** *M3, Royal sorcerer and sage advisor. Loyal 8, Modest 5.* Jarrett is a boastful and flashy mage of few accomplishments. He's a real showman, using his *phantasmal force* spell and *resist fire* ring to good effect. At official functions he likes to stand in the center of the hearthfire and spout thaumaturgic gobbledegook to awe the assembled clansmen and guests.

Jarrett has a lovely enamel travel kit, which he hauls around everywhere with him. Inside the kit are over twenty potion bottles, each labeled as various magical potions (i.e., *diminution*, *clairvoyance*, *giant control*, etc.). Only two are actually

potions—*healing* and *plant control*. The rest are poisons.

The locals think Jarrett is hot stuff, with the exception of Flosi who knows he's a clown. The natives are so intimidated by Jarrett that they won't touch any of his possessions, and they rattle on about his "evil eye" and his "mastery of the unseen world." Jarrett will scornfully refuse to cooperate with the PCs unless they threaten to expose him as a fraud. In that case he'll either go along with the PCs, or disappear in the middle of the night.

**Einar Bjornson:** *C8, priest of Thor. Honest 15, Trusting 15, Loyal 17.* Knows the *raidu* and *tiwar* runes. Einar carries Thundersmith, a *hammer +1*, the handle inscribed with *tiwar* and *as* runes. The hammer is a cult heirloom of the household godar of the Vastergard dynasty, with runes inscribed by an long-dead Thor priest. The entrance to Einar's residence and the household shrine of Thor are guarded by a *raidu* rune, and the shrine's runestone (dedicated to Thor) is marked with the *sowelu* rune, also inscribed by one of Einar's predecessors.

Einar is young and earnest, completely dedicated to Thor, and confident that the Immortals are on the side of Lawful Might, such as his lord Harek represents. Nominally the leader of Harek's berserkers, DMs should think of Einar as a rookie lieutenant in command of a squad of world-wise veterans. The berserkers are formally polite and obedient, particularly in following Einar's fervent invocations to Thor, but they always go their own way. When Einar is out of earshot, they mock him.

It has never occurred to Einar that things might not be exactly as they seem. Never. PCs trying to explain subtle plots to Einar are wasting their time. He supports the accepted guardians of truth and justice: Harek, Hoskuld, and Thor. Einar will trust PC Thor cultists and distrust others, especially magic users, thieves, and dwarves.

### The Berserkers

Think of these characters like the bad-guy

surfers in a highschooler beach movie—with souls of flint. These fellows bully anyone who looks like he ought to be able to defend himself. They are not cowards—they'd just as soon pick on someone twice their size to show off. They cheerfully heap verbal abuse on magic users, clerics of other cults, dwarves, halflings, and elves, with an endlessly crude locker room wit. They are really loyal to three concepts: one another, Thor, and serious partying. They wear chain and carry shields and arms for public occasions and for weapons practice—which means they're almost always fully prepared for action.

**Lodin:** *F10.* Carries the magical broadsword *LifeStealer*, a *sword +2* with the *energy drain* power (D&D® Expert Rules, p. 59). Older man, quieter than most. Drinks a lot; subject to sudden rages. An outlaw, rumored to have accidentally slain his son with the sword.

**Mord:** *F9. Shield +2, sword +1.* Social leader and chief wit. Loves to maneuver others into fights over "honor" and other notions he finds funny.

**Knut Kin-slayer:** *F8, Peaceful 2, Forgiving 2. Hammer +1.* Earnestly dedicated to his lord and to Odin, Knut is otherwise a homicidal maniac. His lord reckons that Knut's violent reputation is well-known, and that those who fool with him deserve what they get.

**Thorgest One-eyed:** *F6. Reverent 18, Courageous 18, Loyalty 18.* Thorgest is a deranged fanatic, totally dedicated to Odin. Everyone knows he put out his own eye as a measure of his dedication. If shown a sign from Odin (command of an Odin cleric, a wise woman's prophecy, or persuasive PC mumbo-jumbo), Thorgest acts instantly and without concern for his well-being. Thorgest is the only Odin cultist among the berserkers, but he is so totally dedicated the others don't hold his cult affiliation against him.

**"The Hook":** *F5.* Lost his left hand in combat. In its place, he wears a wooden fist with a metal hook protruding. He fights with the hook (damage as a dagger, second attack, -2 to hit) and a sword in the other hand.

**Ofeig:** *F4.* Very dull-witted, he always

## ADVENTURES

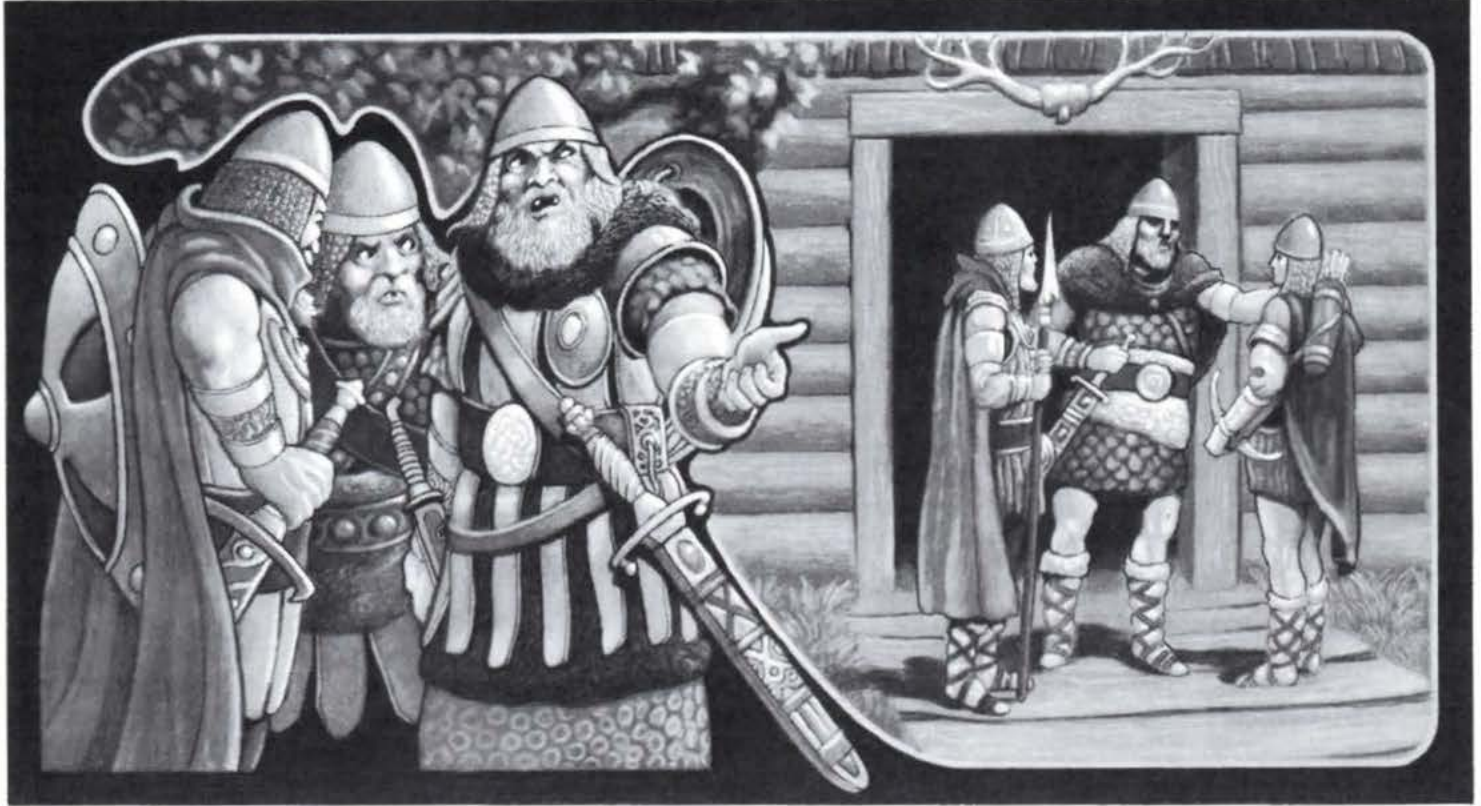

laughs about two minutes late.

**Sven:** *F2. Trusting 14.* Lowest in the pecking order. Young and eager to prove himself to his companions, Sven is often pushed around for general entertainment.

**Horsa:** *C4. Mace +1.* Quiet and fairly bright. Older than Einar, Horsa came up through the ranks. He figures himself to be the ideal leader of the berserkers, so he's just waiting for Einar to make a serious mistake.

**Bersi:** *C3. Forgiving 1.* Bersi has an exceptionally vicious sense of humor. He makes proper observances to Thor, but is really a Loki cultist, and uses reversed spell effects when they cannot be traced back to him. Flosi does not know Bersi is a Loki cultist, nor vice versa.

**Finn:** *C3.* This character is a party animal. He has a stupendous capacity for food and drink, and occasionally lets loose with a blood-curdling shriek he calls his "war cry." The other berserkers always cheer and clap after this prodigious noise.

### **The Personal Guard**

The Guard remains personally loyal to Harek, though they are bitter that the berserkers have been raised above them as the jarl's closest companions, and that the berserkers are now seated with honor at Harek's right hand. They do not like Hoskuld, and consider Atli or Hogni more worthy of being Harek's successor.

The members of the Guard have a vague distrust of Flosi and Jarrett, suspecting them of having a hand in the trumped-up charges of treason that caused Atli and Hogni to be banished. However, they believe Einar to be the prime agent of the conspiracy to remove Atli and Hogni, since Einar and the berserkers have risen in Harek's favor since he outlawed his elder sons. They believe the evidence is self-evident: Einar and the berserkers have profited, so it must be Einar and the berserkers at the root of the plot. When challenged on their reasoning, it will be clear that these men are just poor judges of character. They do not realize that Einar hasn't the subtlety for

such a conspiracy.

Brand, Thorgils, and Stemkel know where Atli and Hogni are, and Brand remains in contact with Hogni by secret messages carried through the Frey cult priesthood. These men are reluctant to reveal this knowledge, since it is evidence of disloyalty to the jarl. Only if the PCs have earned the trust of Brand will the others be willing to speak openly with the PCs.

Once a more imposing force, Harek's Personal Guard has declined in quality since the outlawing of Atli and Hogni. Some noble fighters have found excuses to absent themselves from Harek's Hall, and their places have been assumed by green social climbers unaware of the weakening status of clan Vastergard. Only Brand, Thorgils, and Skamkel remain from the earlier period of the Guard's glory. They do what they can with the new men, but the newcomers are not first caliber, and they lack the morale typical of the unit at its height.

**Brand Bear-Heart:** *F11. Sword +1, +2 vs. spellcasters.* Frey cultist. Leader of



the Guard, respected and trusted.

**Thorgils:** *F8. Trusting 5. Spear +1.* Frey cultist. For no reason, suspects PCs of conspiring with Einar to accuse the whole Personal Guard of treason.

**Skamkel the Hairy:** *F5.* Fine archer (Dex 18). *Arrow +2.* Frey cultist.

**Thrain:** *F3. Shield +1* Odin cultist.

**Hakon Hawk-Beak:** *F3.* Frey cultist.

**Seamund:** *F3.* Odin cultist.

**Olaf:** *F2.* Thor cultist.

**Kalf:** *F1.* Thor cultist.

**Arnor:** *F1.* Thor cultist.

### Other Personalities

**Kalf the Dueler:** *F12* but fights as *F2* due to old age. *Dogmatic 18, Modest 2.* The Dueler is the doddering younger brother and counselor to the jarl. Kalf sincerely but foolishly recommends rejection of new ideas or requests for aid from any but clan members. To persuade him otherwise, PCs must show him he is wrong without embarrassing him before his jarl and kin. When he sees the truth, he accepts it, if he is not blinded by wounded pride.

**Skapti the Skald:** *C2. Open-Minded 15, Cautious 5.* Skapti is a young traveling skald, searching for heroic sagas to embellish with his poetry. He seeks out ancient forgotten stories on runestones, and follows what heroes he can find, hoping to witness a stirring deed. He is guesting at Harek's hall, killing time and fattening up while he decides where else to seek adventure.

Skapti finds some interesting folk here, but not necessarily those who expect his attention. There is Black Aggie, with her spooky stories; Erika, with her fanciful imagination; and Lodin the Berserk, whose dark moods and rages seem romantically tragic to Skapti.

The PCs, of course, look like a guarantee of adventure to Skapti, and he'll attach himself to them like a leech. The PCs cannot get rid of him, and he is so curious and rash that he's bound to get them into trouble.

**Black Aggie (Sigrid Halldorsdottir):** *Wise woman 14. Loyal 2, Honest 18.* Black Aggie is a dirty, unkempt old wom-

an with piercing eyes and sharp features. She has been with Harek for decades, and he keeps her around as a sort of good luck charm. He places little faith in her runestone readings, but he respects her knowledge of dark powers and local legends.

She remains hidden in the shadows, serving her lord's will. She is learned in poison, rune, and legend lore, and has the power to turn any character's exaggerated boast into a curse which follows the character until he or she makes good on the claims.

Flosi has made oblique references to possible mutual interests, but Black Aggie has pretended indifference. She is interested only in herself, but will sell out to the highest bidder. If the PCs turn to her for information or assistance, they'll pay dearly for it. If they are careless and allow Flosi to purchase Black Aggie's assistance, Flosi will make good use of the wise woman's poison lore and magical abilities.

**Servants, Laborers, and other Residents:** *NM.* The other minor NPCs in this scenario divide into two groups, neither of which can be much help to the PCs.

There are those who are too dull-witted or complacent to notice the gradual decline in the fortune and reputation of their lord and his clan. They can't understand the PCs prying into clan affairs. Angry and indignant, they will not listen to any talk of treason or conspiracy, and will report such talk at once to Harek, Hoskuld, Einar, or Flosi.

The second group is so discouraged or fearful that they avoid any conflict with the jarl or his favored followers. In particular they will avoid the PCs. Even if cornered privately, they will obstinately play dumb, convinced that the PCs are spies.

### The Storyline

Valdahelm is a magical silver-plated helm decorated with gold and gems. When worn by the rightful ruler of the Vastergard clan, the command word "freakfast" automatically raises the wearer's Charisma to 18.

Flosi the Fox has arranged, with the aid

of a Modrigswerg craftsman, for the helm to be tampered with. Now in addition to its original effect, the wearer (Harek) casts on himself a *charm* spell when the command word is spoken. Because the user casts the spell upon himself, Harek receives no saving throw and the spell-turning power of his other magical possession, the Hammer of Justice, is not activated.

The *charmed person* is controlled by the owner of a magical amulet in the form of a simple belt fastening, currently in the possession of Flosi the Fox. Only three people at the stead know that Valdahelm has been tampered with: Flosi, Gjaflaug, and Hoskuld.

Harek invokes the magical powers of Valdahelm at least once a day at the evening meal, and at any other time he desires to impress those around him. Harek is growing paranoid and distrustful in his old age, and feels more often the need to invoke the authority of the helm to certify his lordship. Flosi encourages Harek's paranoia, while maintaining the pretense that Flosi himself is a trusting and guileless person. For example: "Lord, how you do treat the captain of your own Personal Guard, as if you do not trust your own noble warriors? Would they conspire against their rightful lord? I'm certain not. True, they hold no affection for Hoskuld, and they spoke well of those you outlawed—but they are loyal, surely, and follow your will, do they not?"

### Staging the Scenario

The Jarl's Hall is a complicated detective roleplaying scenario, featuring numerous NPCs with complex motivations, and a plot full of distractions and red herrings.

Players who like a lot of action will enjoy this scenario best if you guide them through it along the suggested sequence of events listed below. Players who enjoy roleplaying and detective work, on the other hand, may be happier if you don't lead them by the nose. They may prefer to be tossed into the situation and left to find their own way through the posturing and pretenses of the NPCs, uncovering

## ADVENTURES

the central plot of subversion on their own.

### Introduction to the Scenario

The PC party is asked to visit the Vastergard Great Hall and discover what influence is undermining the status and honor of the Vastergard clan and its ruler. There are a number of individuals or organizations who might request or command such a service:

- Ragnar the Stout, war leader of the Jarldoms, is alarmed by the weakening of an important supporter and ally. He offers the party a handsome sum to act as his agents.
- The Odin or Frey/Freyja priests of the domain are concerned for their followers. They request the services of one or more of their followers among the PCs to go investigate.
- Brand Bear-Heart, friend or relative of a PC's family, sends a message requesting aid on the basis of clan, family, or friendship.
- The PCs encounter the outlawed Atli or Hogni, and are promised wealth and positions of honor if they will free Harek from whatever evil influence has turned a father against his sons.

**Welcome to the Hall:** The PCs go to Harek's Hall. They may go directly to the hall or decide to scout first, speaking with villagers or local priests. They present themselves to Harek, are welcomed and offered hospitality as is customary. Each PC is honored according to his reputation and character class (*i.e.* noted fighters are given recognition and offered sleeping space in Kalf's Hall; magic users, dwarves and such are treated coolly, and offered sleeping space in the guest hut).

Each of the major NPCs is introduced by name to the PCs, and the PCs are encouraged to make themselves known to the jarl's household. The berserkers will engage in some restrained and dignified boasting and PC-baiting. Then the PCs are dismissed, permitted the liberty of the Hall, and requested to attend at a feast in their honor that evening.

**The Jarl's Feast:** The feast is held in the Great Hall. The berserkers and Einar sit at Harek's right hand. Hoskuld, Gjaf-laug, Kalf, Skapti the Skald, and Flosi sit at Harek's left hand. The Personal Guard are seated on the left, below the family members, and the PCs are seated on the right, below the berserkers. PCs who drink moderately are mocked by the berserkers, and those who drink heartily must make Constitution checks. Failure receives a penalty of -3 to Dexterity and Reaction.

Skapti suggests a boasting contest, to the delight of all present. Harek requires that the Personal Guard, the berserkers, and the PCs participate. Hoskuld is given the honor of judging the contest.

The DM should alternate between the three groups, beginning with the the characters with the lowest levels. The Personal Guard are subdued and uninspired in their boasting—a hint of their poor morale. The berserkers are unrestrained and taunting in their boasts, making magic users, thieves, dwarves, or other low-status PC classes the butts of their jesting boasts. (For example, Finn boasts of once harnessing six dwarves, then riding across a stream on their backs. "Oh, it was terrible dangerous! Thor's Hammer, those little bald heads are slippery when wet!")

Regardless of the quality of the PCs' performances, Hoskuld picks one of the berserkers as winner, and that group goes wild: cheering and bellowing, throwing benches and axes, and draining beaker after beaker of ale. During this mad celebration, one of the berserkers "accidentally" whacks a PC, preferably a weaker character like a mage or a thief. (This can be damaging, but definitely non-lethal. If the PCs are a frail bunch, have the berserker do something humiliating like spitting, poking or jabbing—something that calls for a response without calling for a blood feud!)

*What do the PCs do?*

- If the PC strikes the berserker back, a free-for-all ensues between the berserkers and the PCs. The Personal Guard does not get involved. After five to ten rounds of fighting, Harek (who's obviously

enjoying himself) orders a halt to the fight. The berserkers obey, though wherever they think they can get away with it, they take one last cheap shot at the PCs, then look innocent.

Harek sternly asks who started the fight. The berserker who whacked the PC innocently points at his victim and says, "Him. He did it." Regardless of PC protests, Harek orders that PC taken into custody by the berserkers and held prisoner for the rest of the PCs' stay.

- If the PC doesn't strike back, but claims a foul and demands a personal duel, Harek cheerfully agrees. The duel is fought under the *holmgang* customs of no armor, no magic, only hand weapons, to first wound. The duel proceeds normally. However, after first blood is drawn, the berserker takes a cheap shot—again, damaging, preferably humiliating, but non-lethal. Then he drops his weapon, holds up his hands, and looks innocent. The Personal Guard gasp with contempt, the berserkers roar with laughter at the cheap shot, and Harek looks stern but amused. The offending berserker is ejected from the hall with a tongue-lashing from Harek, but the other berserkers sit around smirking and giggling at the PCs.

- If the PCs do nothing in response to being provoked, the berserkers eventually quiet down and wink at each other, confident that they have a pack of wimps to play with.

Finally the feast breaks up. The PCs go to their guest lodgings, as assigned. The berserkers follow them out and yell a few choice taunts, then go back inside the Great Hall to sleep.

**The Hunt:** The next day Harek proposes a little hunt with his guests. Harek, Flosi, Hoskuld, Kalf, Einar, Horsa, Brand, Stemkel, and the PCs are invited to join the hunt. Only leather armor and shield are customary wear for such sport (loaned by the host if necessary), and the only weapons are daggers and spears. Lord Harek wears his chain mail, at Flosi's urging and in deference to his age. Use of magic on such a hunt is considered unsporting, but it is tolerated when

needed to prevent serious injury to the participants.

Stemkel is master of the hounds. The dogs quickly scare up a herd of boars (NA 6; AC 7; HD 3; #AT 1 tusk; Dam 2-8; MV 90'; Save F2; ML 9; TT Nil; XP 35).

Harek, Hoskuld, and the other jarl's-men dismount to meet the boars' charge. (Any character with Horsemanship skill knows it is cowardly to risk injury to one's horse during a hunt.) During the ensuing melee, Flosi casts a single hold person at four PCs who are in the middle of the melee and menaced by boars. Only a PC not in melee and specifically stated as observing Flosi may notice who threw the spell. Even then there will be no proof.

Someone, a PC or an NPC, shouts a warning that hostile spells are affecting the party. The party rallies to protect the jarl, who is genuinely alarmed. Harek invokes Valdahelm, shouting "Rally to me!" The jarl sends Stemkel and Brand to search the forest for ambushers, calls off the hunt, and returns to the Hall.

Harek then summons each PC and NPC individually, and questions him on what he saw and what he believes happened. Afterwards, he says, "I must retire to consider this strange occurrence. Double the guards at the gate and on the walls. No one is to leave or enter the stead's walls unless I give permission. Please join me again for dinner this evening."

**The Drinking Contest:** At dinner, Harek is in a black mood, and talk is hushed. Finally, in an attempt to lighten the mood, Einar proposes a drinking contest. Harek seems cheered by the prospect, and he invites the PCs to participate. Harek also invites Hoskuld, Skapti, the berserkers, and the Personal Guard, and boldly announces that he will also participate.

After each round of ale downed, make a Constitution check for all participants. Those who pass remain standing. Reduce their Constitution by one point, and repeat the process. The last man standing is the winner, and receives a golden plate from Harek's treasury, awarded by the jarl with slurred congratulations as he is held

upright by Flosi and Kalf. Harek then slips into slumber at the table.

Courtesy demands that none leave the table without his host's permission, so everyone sleeps at the table that night. None of the NPCs attempt to leave. If the PCs attempt to leave, the berserkers rouse themselves in earnest, drunken indignation at the insult to their host: "Hey! Sid-down or we'll...we'll... \*BELCH\*...rip yer arms off!" PCs should understand that, even if the berserkers can't manage that threat right now, they'd get to it later.

**Challenge to Holmgang:** When the PCs wake, there is a lot of muttering and confusion as all the hungover heroes (PC and NPC alike) crash around in pain.

Suddenly, Knut Kin-Slayer, who can't find his *hammer +1*, picks a PC and bellows that he has stolen his weapon. (In fact, Flosi took the weapon and hid it the preceding evening.) Harek immediately demands that Knut offer proof of his accusation. Knut pouts, and demands a trial by combat to determine the truth. Einar offers to cast a *detect lie*, but Knut stubbornly insists on a trial by combat, claiming that the PC is protected from truth magic by his spellcasting PC friends.

Harek regretfully agrees that, by custom, Knut is entitled to trial by combat. Brand reminds Harek that in such cases, the accused may name a champion to fight in his place. Harek agrees, and declares that the duel shall be fought as a *holmgang*, to fight with blunted weapons "until one cannot continue." (This is to unconsciousness or death. Only half of any damage given is permanent; when the victim falls to zero hit points or below, he is unconscious. See more about *holmgang* in the PC Book, p. 8.)

If the PC wins, the berserker is required to apologize to the PC. If the berserk wins, the PC is required to return the stolen object or pay compensation for it. If the PC loses, then Brand offers to pay compensation for the lost weapon himself, disgusted by the berserker's behavior and ashamed of the hospitality of his lord's hall. Brand and the rest of the

Personal Guard then leave in a huff. Harek, shamed, apologizes to the PCs and excuses himself, taking refuge in his private quarters.

**Revealing Flosi's Role:** The PCs may already have made some inquiries that point to Flosi's power over Harek. However, if the PCs haven't discovered clues by this time that permit them to act against the evil priest, they are probably getting frustrated. Here are three ways that NPCs can help point the way to action for the PCs:

1. Black Aggie has decided to reveal Flosi before he causes the clan's complete destruction. She's decided to use the PCs as her pawns. If the PCs succeed in revealing Flosi as a villain, her place at Harek's Hall is once again secure. But if the PCs fail and Flosi overcomes their threat, Black Aggie's part is not revealed, leaving her to make her peace with Flosi.

Black Aggie leaves the following anonymous hint, written in runes, where a PC cleric will find it: "*Detect magic—the helm or the jarl? Detect magic—Flosi's belt.*"

2. Jarrett slinks up to a PC mage or cleric and hints broadly that he knows something worth a pair of magic items. If the PCs come across with any two magic items as payment, Jarrett reveals that he has ESPed Flosi and discovered that Flosi has *charmed* Harek. "Damned if I know how the pipsqueak does it, though. He sure ain't no magic user. Besides, even if he was, that *charm* spell isn't very reliable. A strong-willed old hero like Harek ain't likely to stay under its influence." Then it's up to the PCs to discover the *charm* effect of Valdahelm and Flosi's control amulet on his belt.

3. Skapti the Skald comes to the PCs and tells them some things he's heard from Erika:

"Look, she's just a little girl with a wild imagination, but she's pretty bright. She says her brother Hoskuld has been sneaking out on moonless nights, meeting people in the forest, then disappearing. She also thinks Flosi is a spellcaster. She's seen him talking to this trained rat that her brother has."

## Adventures

If questioned further, Skapti mentions that Hoskuld also speaks to this pet rat, although it doesn't occur to either Erika or Skapti that this is very unusual... "After all, everybody knows that Hoskuld is a cleric, and clerics talk to animals all the time, don't they?"

In fact, it is through this pet rat that Flosi communicates with Hoskuld on matters concerning the conspiracy to control Harek and rule the Vastergard clan. Since Hoskuld and Flosi are never seen together, no one would ever suspect them of conspiring.

Interrogating this rat will reveal all the details of the plot (from a ratly point of view): how the jarl's magic helm has been tampered with, and how Flosi has promised to make Hoskuld the next jarl in return for Hoskuld's cooperation. Of course, obtaining an interview with the rat is no easy matter, since it lives inside the private quarters of Harek's Hall, where only family members, servants, and trusted advisors like Flosi are permitted. One way is to obtain the cooperation of Erika, who is more than willing to kidnap the rat and deliver it to the PCs.

**The Big Action Climax:** Circumstances should have reached the point by now where the players are really hot for righteous justice. The ideal setting for this climactic confrontation is an evening feast in Harek's Hall.

After all the recent trouble, everybody is on edge but no one can refuse the lord's request to join him for dinner. Harek starts out by invoking his helm, turning on his Charisma, then apologizing to his guests and his followers for the unfortunate events of the last few days. He takes the responsibilities upon himself, as lord and host. Harek begs everyone to abandon their grudges and grace the hospitality of his table with polite talk and pleasurable feasting.

But before Harek takes off the helm, Flosi stands up, thanks his lord, and begins a speech in a quiet voice:

"Indeed, the events of the last few days have been regrettable—and all the more for the distress and unwonted peril that has threatened you and your clan and

kin. I welcome the opportunity to set things aright, particularly to..." (Flosi's voice changes to one of confident command, and he points boldly at the PCs) "...reveal the agents that threaten you and all of Vastergard! Behold—these folk come as assassins and spies! SIEZE THEM!"

Everything goes crazy. Under Flosi's *charm* command, Harek jumps up like a puppet and orders his men to seize the PCs. Einar—confused, but loyal and obedient—immediately hurls his berserkers and spells into the melee. Hoskuld starts popping off spells at the PCs, having been warned by Flosi of the coming confrontation.

On the other side, Brand and the Guard, along with any NPCs friendly to the PCs, will hesitate for the first round, surprised. The PCs themselves are probably surprised in the first round, but need only contend with a spell from Hoskuld in that round.

In following rounds, Brand, the Personal Guard, and any friendly NPCs rally to the PCs' aid. Brand and the Personal Guard have been spoiling for a fight with the berserkers for months; they engage Einar and his men. The PCs are fairly free to pick their targets, and Flosi, Hoskuld, and Harek are logical opponents. However, the PCs should note that the Personal Guard is outgunned by the berserkers in spells and character levels. They'll need PC help or they don't have a chance.

Skapti will remain neutral, protecting Erika, unless befriended by the PCs. Kalf, Black Aggie, and Gjaflaug try to withdraw to Harek's private quarters. Erika may be an excited spectator or, if befriended by the PCs, she'll play some trick on Flosi or Hoskuld, causing them to lose rounds of actions. Jarrett will stay clear and protect himself, unless he previously made a deal with the PCs.

If a PC can get to Harek, remove Valdahelm, and dispel the *charm* or replace it with another *charm* spell, Harek will realize he's been duped. He'll order everyone to stop fighting. Einar will obey, and deal with any berserkers who fail to obey. If the PCs can, in a very few words, tell Harek that Hoskuld and Flosi are respon-

sible, he'll order Einar and the berserkers after Hoskuld and Flosi instead—probably a quick and easy win for the Good Guys. Wordiness will mean long arguments and counteraccusations from everyone.

On the other hand, a pitched battle of PCs and friends versus Harek, Hoskuld, Flosi, Einar, and the berserkers should be pretty close. If things start to turn against Flosi, he'll run, heading for the shed where two of the jarl's favorite horses are stabled. Hoskuld is too dull and unimaginative to escape. Einar and his boys will fight to the death at the command of their lord. If Einar is shown that his lord has been ensorcelled, Einar will use his skills and spells to stop the fighting and puzzle out his next move.

If the PCs fail to overcome Harek, Flosi, Hoskuld, and friends, the PCs and the Personal Guard may expect to be either killed or captured. Captured characters and NPCs are judged guilty of treason, stripped of their possessions (as compensation for any damage or injuries done to Vastergard clan), and outlawed from the domain. Harek gives them a one hour headstart on foot, then he sends his berserkers after the unarmed outlaws.

**The Wrap-up:** The PCs need to hold their own long enough to plant doubts in Einar's mind. Einar is basically a good guy, and smart enough to realize that a conspiracy between Flosi and Hoskuld would explain the peculiar outlawing and banishment of Atli and Hogni. Einar is not obligated to follow the orders of an ensorcelled lord.

Once doubts are planted, Einar gets his men under control. The berserkers and the Personal Guard are deeply involved in their own grudges, but both groups are loyal to their lord and their commander. Also, like all Northmen, they are unsettled by magic, and deeply disturbed at the idea that their lord might be a spell-caster's puppet.

Once things are under control, Flosi and Hoskuld are doomed. Flosi realizes it at once and tries to escape on horseback, which alert PCs should be able to prevent. Hoskuld is not so clever, and con-

tinues fighting until slain or disabled.

When Harek is freed from Flosi's magical control, he immediately orders Flosi and Hoskuld taken prisoner, and invites the PCs and NPCs to explain the mystery. After the conspiracy is explained to him, Harek immediately cancels his judgment of Atli and Hogni as outlaws. He then strips Flosi and Hoskuld of their possessions and declares them outlaws. Harek gives them a one hour headstart on foot, then he sends his berserkers after the outlaws. The PCs are invited to join in the hunt.

### Staging Tips

Here are a few strategies the PCs may take to investigate the mysteries behind the decline of the Vastergard clan—and the responses the DM can make.

1. **Fantasy Detective Techniques:** In addition to mundane detective techniques like questioning informants, searching suspect's residences for physical evidence, and tailing suspects, fantasy characters have spells at their disposal, and NPC opponents have counterspells. Two spells—*ESP* and *clairvoyance*—are particularly useful. An *invisible*, *silenced* tail can learn a lot while observing a suspect.

It is extremely discourteous to cast spells without a host's or the subject's permission, particularly in the Northern Reaches where magic users are distrusted. Any character observed casting a spell can be challenged to a duel for the offense, and placed under house arrest. With caution and wit, PCs should be able to cast spells unobserved or when others are distracted. The results:

- Flosi is effectively absorbed into his assumed role as an elderly, well-meaning advisor to the jarl. His surface thoughts as read by *ESP* will usually reveal nothing to contradict that image. However, when he believes himself unobserved, he slips out of the advisor personality and into his scheming personality; *ESP* at this time may reveal his plots a-hatching.

- Hoskuld is less well-disciplined, but also less intent on controlling his father than on sharpening his skills as a follower

of Hel. An *ESP* cast on Hoskuld is likely to catch him scheming on his plots with the Hel cultists—generally riding around and digging things up out of graveyards—than on the conspiracy with Flosi.

- An *ESP* of Harek reveals no more than would be expected of the jarl: cautious suspicion of his unfamiliar guests, and concern for his household and clan. However, Harek's thoughts reveal a pattern—he constantly wonders what Flosi would advise on every topic that comes to mind. This is not too odd, given that Flosi is a trusted advisor, but a magic user looking for evidence of tampering with Harek's mind would have reasonable grounds for suspecting Flosi.

*Detect evil* spells give the PCs potentially misleading information. Harek, for example, always detects as evil—that is, as having hostile intent toward the PCs. This is actually the effect of Valdahelm's enchantment and Flosi's counsel, rather than a sign that Harek is evil. Further, the only other NPC who initially detects as evil is Hoskuld, who is bad news and too dumb to conceal it. As the scenario progresses, and Einar and his berserkers get on the wrong side of the PCs, they will detect as evil. The attitude of other NPCs toward the PCs may become hostile according to the PCs' action. Flosi takes great care not to reveal any hostility toward the PCs except during the hunt, when he is plotting to bushwhack the PCs, and in the late stages of the scenario once he decides they are a threat that must be eliminated.

**DM Note:** The interpretation of the *detect evil* spell in your campaign may differ from the interpretation given above. If so, the PCs can use the spell in a more straightforward way to identify the bad guys.

2. **Seeking NPC Allies:** This is a wise idea. Friendly NPCs can assist with the investigations, and stand by the PCs in the climactic melee.

Some NPCs, like Einar and the berserkers, are dogmatically loyal to Harek and his followers and automatically suspicious of strangers. They won't be very willing to listen. Also, while the ber-

serkers are technically neutral, they are as bullying and mean-spirited as orcs, and unlikely to be good allies.

NPCs like Jarrett and Black Aggie are strictly self-interested. Unless the PCs offer substantial rewards, they are very unreliable allies.

Some NPCs, like Skapti, Erika, Brand, and others, are naturally inclined to aid the PCs. They can believe in the PCs' good intentions, and will listen to evidence that their lord is in danger.

3. **Covert Attacks:** This is a bad idea. Killing anyone in the household except by accident or in a lawful duel is violating the hospitality of the hall. It is the jarl's right to judge, not the PCs' right. Even if they uncover the plot and release Harek from his enchantment, the jarl is tradition-bound to outlaw murderers from his land.

4. **Seeking out Atli and Hogni:** Atli has concealed his identity and signed on as a crewman with an Ostman pirate. The ship is currently operating off the coast of Ostland. Atli is thus unlikely to be available to the PCs.

Hogni is living under an assumed name in Norrvik. He stays in touch with Brand through messages sent via itinerant Frey/Freyja priests. The PCs can travel to Norrvik to enlist Hogni's aid. Hogni will refuse to become involved unless the PCs have solid evidence that his father is being magically controlled. Hogni already assumes his father is being influenced by his advisors, a common enough problem in a jarl's household, and feels there is nothing he can do about it lawfully.

If the PCs gain Hogni's aid, he will return to Harek's Hall only if the PCs can devise some very effective disguise; Hogni has been outlawed, and to return without permission is certain death.

### Alternate Scenarios

The overall setting and NPCs of the Jarl's Hall scenario are easily adapted for other adventures of your own devising. Situations and personalities may need adjusting to fit the outcome of any scenarios played earlier.

## ADVENTURES

### Setting Up a Northern Reaches Campaign

#### *The Hospitality of the Hearth*

The conventional starting place for many adventures is the tavern. In the Northern Reaches, starting in a tavern is feasible in towns and large settlements—any place travelers would normally shelter and eat in a commercial establishment.

However, in smaller communities, in remote borderland regions, or in tradition-bound Ostland, travelers are expected to shelter and eat with local people. The stranger must be shown courtesy and hospitality—this is a deeply-ingrained feature of Northland culture.

In return, the petitioner is expected to be polite and respectful. It is customary to offer payment, in money or in value (work or barter), for the food and lodging that are provided. In many cases, the offer is refused. On the other hand, where the guest sees the need is great, it is thought proper to be quite generous.

An important part of the ritual courtesy is the sharing of news and gossip. Folk in small settlements or in remote regions get little in the way of news, and eagerly await it from travelers. At the same time, the host is expected to hold up his end with information about local events.

This cultural quirk gives the DM an excellent way to offer players adventure hooks, hints, and clues important to the scenario, or general information about local people, places, things, and legends. In this way, the host, his family, servants, and hired laborers become informants just as a taverner and his clientele are informants in a conventional tavern setting.

#### *Population Distribution in Game Terms*

The following describes the distribution of various character types by percentage in a typical Northern Reaches population. Non-adventuring character types are briefly described in terms of their ability to fight at need. This information is useful to establish the resources of a village or that of a whole region for self-defense when the area is attacked by

raiders, invaders, or monsters.

**Clerics, Magic Users, Thieves, Demi-Humans, and other Adventurers:** 1%.

Various classes and levels. Only a fraction of this number are active adventurers at any given time.

**Non-Adventurer Dwarves:** 2%.

D1—assorted weapons, 30% chain and shield. Almost all dwarves are armed. Many dwarves who never considered soldiering or adventuring still cherish the family arms and armor handed down as heirlooms.

**Elite Veterans:** 2%.

F11-36—jarls, personal guards, heroes, adventurers. Any weapons and armor; 100% with enchanted weapons, armor, etc. With rare exceptions, all clans are ruled by able fighters of 11th level or higher. Powerful clanheads may have several such veterans as close relatives or as personal guards.

**Armed Veterans:** 10%.

F3-10—full-time warriors, soldiers, or adventurers. Assorted weapons, chain and shield; 10% with enchanted weapon, shield, armor, or other gear. No more than 20% are actively engaged as fighters at a given time. Many are young nobles, retired and older fighters, and adventurers turned laborers, farmers, craftsmen, and merchants.

**Armed and Skilled:** 15%.

Fighter or Thief 1-2—men and women from teens to late middle-age with weapons, armor, training, and experience. Assorted weapons, shield, 90% leather armor, 10% chain. This includes military recruits, young nobles, and guards, as well as street-tough town dwellers and frontier settlers experienced in conflicts with raiders and monsters.

**Armed but Unskilled:** 10%.

NM—men and women from teens to late middle-age who possess arms but have no training or combat experience. 90% spear & shield; 10% bow. A substantial number of freemen possess arms but have no training or experience in their use.

**Able-Bodied Non-Combatant:** 20%.

NM—men and women from teens to late middle-age; healthy, but no arms or armor. Many of these are women with no interest in warfare. Others are too poor to own weapons, or are prohibited from owned weapons (thralls in Ostland may not bear arms).

**Unfit Non-Combatant:** 40%.

NM, -2 to hit. The children, elderly, sick, and otherwise unfit.

#### *PC Clan Choices*

When creating Northern Reaches characters with the procedures listed in the Player Book, players are directed to consult with the DM before choosing clans. Here are factors to consider in making your choice.

**Alternative 1:** All PCs are from the same clan chosen by the DM. This has the advantage of giving the player characters a reason for staying together and cooperating—clan loyalty. It also means that if you use requests or orders from clan leaders as scenario motivations, all party members will be under the same compulsion to accept the appointed task.

**Alternative 2:** PCs are from different clans, but the DM limits or actually chooses which clans. The simplest form of this is restricting PCs to clans from a specific region or nation.

There are several considerations here. First, note that many Soderfjord clans have intrinsic political and clan conflicts. If you plan to develop these during the campaign, it is unwise to have player characters from enemy clans in the same party.

Second, Soderfjord and Vestland have more open societies and plenty of wilderness, and are better settings for lower and middle level wilderness and campaign play.

Finally, certain clans have specific roles in the campaign background—for example, the Ostman clan of Kalslo Island is established as a pirate/rebel clan opposing the powerful clan that rules Ostland. Plan ahead, and consider what clans that you intend to develop (and how) as important elements in the overall campaign narrative.

**Alternative 3:** PCs choose their own clans without DM guidance. This can

cause intraparty squabbles and scenario problems when clan membership plays an important role in the adventure. If the PCs will do most of their adventuring in wildernesses, dungeons, or outside of the Northern Reaches, this is not a concern.

### Wise Women (Witches) —————

This NPC class of magic users is unique to the Northland cultures. Wise women have the Read Runes and Deceive skills, and may use the following spells. Spells marked with an asterisk may be reversed.

#### First Level Spells

*Detect Evil*: L1 magic user spell (B41).

*Detect Magic*: L1 magic user spell (B39).

\**Light*: L1 clerical spell (B26). Will know both light and its reverse at first level.

*Prot/Evil*: L1 magic user spell (B40).

*Interpret Runes*: L2 clerical spell (as described in Player Book, p. 27)

#### Second Level Spells

*Ventriloquism*: L1 magic user spell (B41).

*Charm Animal*: This spell effect is identical to that of a *charm person* spell (B39), but any one normal animal may be affected. The animal may make a saving throw vs. spells to avoid the effect.

*Detect Invisible*: L2 magic user spell (B41).

*ESP*: L2 magic user spell (B41).

\**Remove Curse*: L3 clerical spell (X6). Knows spell and its reverse at 2nd level.

#### Third Level Spells

*Charm Person*: L1 magic user spell (B39).

*Clairvoyance*: L3 magic user spell (X11).

*Fly*: L3 magic user spell (X12).

*Phantasmal Force*: L2 magic user spell (X11).

*Sleep*: L1 magic user spell (B40).

#### Fourth Level Spells

*Charm Monster*: L4 magic user spell (X13).

*Dispel Magic*: L3 magic user spell (X11).

*Locate Object*: L4 clerical spell (X6).

*Polymorph Self*: L4 magic user spell (X13).

#### Fifth Level Spells

*Magic Jar*: L5 magic user spell (X15).

*Polymorph Others*: L4 magic user spell (X13).

*Massmorph*: L4 magic user spell (X13).

*Pass Wall*: L5 magic user spell (X15).

#### Sixth Level Spells

*Anti-Magic Shell*: L6 magic user spell (X15).

*Conjure Elemental*: L5 magic user spell (X14).

*Death Spell*: L6 magic user spell (X16).

*Word of Recall*: L6 clerical spell (X9).

### RUNE MAGIC —————

**Personal Runes:** On rare occasions, PCs may receive a unique personal rune from their patron Immortal. This is usually only appropriate if you are about to seriously challenge that character. For example, if you want to encourage a PC to take on a long-term, difficult task that he or she would sensibly refuse, it may be time to provide a rune. The rune should have some relatively significant magical effect that almost compensates for the PC's uneasiness about the task.

**Preventing Abuse of Runes:** DMs will want to carefully consider the possible misuses of invented runes. Just as with other magical artifacts, take the time to look for loopholes in the description of powers before handing the rune over to a player. DMs may also wish to gradually introduce alternate powers for the runes already supplied. The same warning applies. Note that many of the rune powers are already available as spells of one sort or another. This suggests that spell powers not adapted to date might make good starting ideas for new rune powers.

If you think the players are likely to abuse the runes, establish a precedent for cosmic alterations in the functions of runes early in the campaign, just in case one rune power turns out to unbalance everything. For instance, provide a myth of how a rune once meant some wonderful thing, but some scumbag abused the

power—so Odin forever altered the rune, and it never worked that way again.

**Artifact Enhancement:** Runes were widely used by the historical Vikings to identify their personal belongings, and for the magical enhancements they believed the runes could offer.

Visual aids can improve the fun of a game all around. Players can draw their rune-inscribed items on their character sheets for easy reference. Typical items for rune inscription include weapons, ships, armor and shields, arrows and sling stones, amulets, etc.

The DM can make drawings on cards of objects that the players might come across during their explorations and adventures, then hand out the cards when the PCs actually find them.

### Preventing Abuses of the Skill System —————

Oppressed players usually try to figure out some way to use the rules to make their player characters' lives more safe and rewarding. In the process, they may try to milk the skill system introduced in the Player Book for more than it's worth. The suggestions below offer ways to discourage such abuse.

- Assess bonuses and penalties for skill checks according to the difficulty of a given task. Many tasks within a described skill should be considerably more or less difficult than is indicated by the solitary value of the character's statistic.
- Discourage jerky or abusive skill use by penalizing the character if his player is going beyond the bounds of sense. "Sure. Alfgeir can use his Muscle skill to pick up that horse. Of course, if you fail the check, your hernia will teach your buddies all about the color of your insides. Fine, no problem; roll those dice."
- A character normally gets one chance to succeed in a skill check. At your option, a second check may be permitted if the circumstances change, or if the player summons up new resources. Conversely, the repeated use of a skill may also be assigned penalties, given that the skill has already failed on the earlier attempt.

## ADVENTURES

### Using Character Traits

Remember that PCs are not obliged to use traits. Even if they do, the DM should never try to force a player to run a character in a way that the player feels is inappropriate.

For NPCs, it's not necessary to roll up in advance the full selection of character trait scores for every NPC you create. Whenever you encounter a situation where a character trait might influence an NPC's actions, consult the Character Trait Table on page 10 of the Player Book, and roll up that trait on the spot. Record the trait score for future developments affecting that NPC.

Major NPCs may need some traits simply assigned to them, to reflect the personality the DM requires at a certain place and time. However, once determined (by whatever method), the traits should not change.

It's not necessary to roll the dice on a trait check to figure out how an NPC would act, particularly in ordinary situations. Once you know the NPC's trait score, it's a reliable guide to the NPC's typical responses.

### Travel on the Overland Trade Route

Players will want to know how many caravans and travelers travel the route... What types of travelers and caravans are common? What do they carry—and what is it worth? What're the tolls? How are the shelters?

**Traffic:** On busy sections of the route (like the section between Soderfjord Beach and Castellán), the DM can assume one might encounter anywhere from ten to twenty private parties and caravans during a day's travel. In the shelters along the Great Marsh Road, the fortified camping areas will be the place to encounter those who pass in similar numbers during cold dry seasons.

**Caravans:** Three levels of caravan are described below according to the value of their cargos—modest, substantial, or fabulous. (See *D&D® Expert Rules*, page 24, for the cost, equipment and skills of heavy foot, light foot, heavy horse, mounted Bowman, and peasant laborer.)

1. Modest (value 2d4 x 100gp): small

ox cart or pack animals, headed by an F1 or D1 heavy foot, with 1d4 peasant laborers and 1D4 NM heavy foot. Typical cargos include hides and leather, raw wool, woven cloth, and tools.

2. Substantial (value 1D8 x 300 gp): several ox carts or wagons, or pack horses. Headed by an F2 heavy horse, 2d6 peasant laborers, 1d4 + 4 NM heavy horse OR mounted bowmen. Cargos include furs, spirits, jewelry, amber, trade metal, tools, weapons and armor.

3. Fabulous (value 1d6 x 1000 gp): one horse-drawn wagon, headed by an F4 or D4 heavy horse, accompanied by a C4 and 2 F2 heavy horse, 1d6 peasant laborers, 2d4 NM heavy horse, 2d4 mounted bowmen. Cargos include precious metals, alchemical components, specialty foods, imported goods, rare books and scrolls.

**Private Parties:** There are three main types of private parties on the Overland Trade Route—adventurers, couriers, and those on personal business (freemen or nobles). The wealthy and important will be accompanied by retainers.

1. Freemen and Nobles: various classes and levels, but mostly normal men in leather with a weapon.

2. Adventurers: various classes and levels.

3. Couriers: 1-4 heavy horse or mounted bowmen of any class, maximum level 8. Couriers carry small, important packages of varying value (1d100 x 20 gp). The items range from business, personal, or clerical dispatches to special delivery of very valuable items, including jewelry, magical items, and other treasures.

Couriers often advertise how tough they are by displaying showy magical weapons and other signs of high status to discourage thoughtful bandits. Of course, lower level couriers also try to look tough.

Very valuable packages are always accompanied by capable spellcasters (clerics for cult dispatches, magic users for business and private packages). These spellcasters use spells early and often when attacked. (Bandits and raiders seldom have access to spellcasters, and must check morale when confronted with magic.)

Overland Trade Route shelters are fortified camping areas on cleared high

ground, with a wooden palisade, a gate tower and one large longhouse. Sheds protect the horses, oxen and vehicles. They are staffed by 10 heavy foot, 20 light foot, 5 mounted bow (scouts and couriers), 10 peasant laborers.

**Tolls:** The toll for traveling the Marsh Road is 10 gp/wagon, 1 gp/person. Charge for shelter is 10 gp/wagon, 1 gp per riding or draft animal, 5 sp/person.

### The Nine Worlds of the Immortal Realms

This section describes the way a historical pantheon (the Norse myths) can be adapted to the *D&D®* Known World. This overview introduces Norse myth directly into the Northern Reaches cultures, and we hope it serves as an inspiration to ambitious DMs playing higher-level campaigns. The treatment is suggestive rather than exhaustive, so modify and elaborate to your heart's content. On page 3 of this book, we've included a list of references on Norse history and mythology that you can get through your own public library.

The Northern Reaches Gazetteer is designed for Basic and Expert play. Characters at those levels have no business casually gadding about in the realms of the gods, but there are circumstances one might imagine bringing these places into play. If you haven't already, read "Clerics in the Northern Reaches" starting on page 24 in the Player's Book before continuing.

**ASGARD:** This Outer Plane is the home of the *Aesir*, one of the two main families of Norse Immortals. The most important gods of Asgard are Odin, Thor, and Loki. In Asgard is Odin's great hall, Valhalla, where Odin's servants and guardians dwell, including the renowned Valkyries (magical warrior women with the powers of *flight* and *plane shift*, among other abilities).

These Valkyries come to the Prime Plane to retrieve the spirits of heroic Northman warriors who fall in combat. These heroic spirits are brought to Valhalla. By day the heroes contest with one another in battle; at night, the dead are raised and all share in



the celebrations in Odin's Hall.

The only access to Asgard is through the Outer Plane called the Rainbow Bridge, a trispace (see the *D&D® Immortals DM Book*, page 10) where magic doesn't work. The Rainbow Bridge is guarded by Heimdal, one of the Aesir, and no mortal or Immortal may enter Asgard without his leave. *D&D®* mortals have no business coming to Asgard without invitation, although a heroquest to Asgard to obtain the aid of a hero of Valhalla is a plausible high-level adventure.

**Vanaheim:** This Outer Plane is home of the *Vanir*, the other important family of Norse gods, represented most prominently by Frey and Freyja. Frey/Freyja cultists might come here to petition these Immortals on behalf of their followers.

**Muspelheim:** This Outer Plane is the home of the fire giants, enemies of the Norse gods. Surt, the sentinel and foremost among fire giants, will lead the forces against the Aesir and Vanir at the final battle, Ragnarok. Muspelheim might be an appropriate setting for high-level adventures. Imagine the Planes of Earth and Fire mixing in an ocean of fire, steam, and tumbling rocks, populated by incredibly unpleasant and powerful fire giants.

**Niflheim:** This Outer Plane, home of the frost giants, is a wilderness of ice, snow, and freezing fog. The river Vergelmir, the Roaring Cauldron, forms a black poisonous, slag-like scum which is the source of all life. Other violent rivers and glaciers—named things like Storming, Frightful, or Bubble-Blasting—flow through the wasteland of ice and rock. The weather is equally vile: torrents of rain, hail, and blizzards.

Beneath the surface of this vacation paradise is the Realm of Hel, the underworld where the Restless Dead dwell. The road to Hel zig-zags down black vertical cliffs, with violent, icy winds whipping up from the lower regions. Gniphellir (Cliff Cave) is the entrance to Hel itself, guarded by the bloody-chested giant hound Garmr.

In Hel are the shades of men, giants, and gods: the Restless Dead. These

shades are still "alive", but their existence is that of a zombie or the walking dead. They dwell on the island Naastrand (Corpse Strand) in a great torture chamber, a vast enclosure of innumerable entwined serpents, whose searing venom drips down on those inside.

The Queen of the Underworld, Hel, lives here. One half of her face is bright and lifelike, the other livid and dead. She dwells with her servants, Senility the Housemaid and Dotage the Thrall.

On the river Fearful (a torrent of swords, knives, and daggers) rides the great warship Naglfar (Nailfarer), a longship built from the untrimmed nails of the dead. At the end of time, this longship will carry the Restless Dead and the Queen of Hel to battle at Ragnarok. The captain of Nailfarer will be the greatest sinner and oathbreaker of all time—Loki the Trickster.

**DM Note:** This is an excellent setting for a heroquest: the PCs seek the Queen of Hel to persuade her to release one of the Restless Dead (a former hero or party member). Alternatively, the PCs may make this journey to question one of those confined here.

First the PCs must navigate the deadly terrain of Niflheim, facing encounters with trolls and gnolls, and powerful frost giants. After descending the narrow trail to Hel, they must defeat or outwit Garmr.

Once in Hel's realm, the PCs must penetrate the serpent-enclosure and make their way to the Court of Hel, there to persuade her with words or gifts. Finally, they may need to steal Nailfarer, or sneak out on the River Fearful with an improvised raft.

**Alfheim:** This Outer Plane is the home of the High Elves. A number of permanent *gates* to this plane are located in the forests of Alfheim, a nation of the Known Worlds to the southwest of the Northern Reaches. The High Elves, ancestors of the Prime Plane elves, are a long-lived, highly magical race. They possess an ancient and civilized culture, with a refined appreciation of music, dance, poetry, magic, and the other sublime arts.

**Svartalfheim:** This Outer Plane is the home of the Dark Elves, ancient enemies of the High Elves, and ancestors of the

Known World's Dark Elves. An evil realm, knowledge of any existing gate is carefully hidden by the Dark Elves.

**Jotunheim:** This Outer Plane was granted to the giant races as a peace settlement concluding a long dispute between the giants and the Immortals. It is inhabited by a variety of giant types, along with a number of other beings.

**SWERGHEIM:** This is the ancestral home plane of the dwarves. The location of this plane and any *gates* providing access to it are secrets concealed in ancient dwarven legends, and known only to a handful of venerable loremasters.

**MIDGARD:** This is an Outer Plane containing a world with a climate and geography similar to our Earth's Scandinavia. Millennia ago, Immortals established here this ideal Norse world, populated by Prime Plane descendants who have had all memory of their former existences erased. The lives of these peoples follow more exactly the legends and history of Earth's Viking cultures, as recounted in the epic poems and heroic myths. This is an ideal place to send any *D&D®* characters wishing to adventure in a true Viking setting.

**YGGDRASIL, the World Ash:** This Outer Plane is filled with a stupendous ash tree the size of several solar systems. Along the branches and roots of this giant tree are gates providing access into the Nine Worlds of the Immortal Realms.

Among the other beings who live upon this tree are the winged dragon Nithog, the Dread Biter, and his brood of serpents: Gnaw-Fang, Grave-Root, and Root-Ripper. These beings constantly tear at the limbs and roots of the tree. A giant ancient eagle, wise but peevish, dwells in the uppermost limbs, and the squirrel Nibble-Tooth carries abusive messages back and forth between the eagle and the dragon.

This is the great tree upon which Odin hung by the neck for seven days, swinging out over the abyss. From this tree he descended with the runes, a gift of knowledge and wisdom that he gave to Mankind.

# Adapting Gazetteers to AD&D® Campaigns

Gazetteer nations can now be set up in other campaign worlds, such as those described in the **FORGOTTEN REALMS™** campaign set, or the **WORLD OF GREYHAWK®** Fantasy Game Setting. When adapted for use with the AD&D® game, the Gazetteers offer exceptionally detailed and unusual backgrounds, colorful characters, and valuable adventure resources for your ongoing AD&D game campaigns.

For DMs wishing to adapt the material in this Gazetteer into an AD&D game campaign, the following notes should be helpful. When making the adaptation of D&D® adventures for the AD&D game, keep in mind that AD&D game characters are somewhat tougher at low levels, but D&D game characters can deliver more damage at mid-to-high levels. Further, AD&D game spellcasters have access to longer spell lists; they may be more powerful and versatile than their D&D game counterparts at equivalent levels.

The D&D game is designed to handle very high levels of play, up to a maximum of level 36. Up to level 20, it is suggested that you keep the same level of experience in the two games. Beyond that, assume that each two D&D game character levels equal one character level in the AD&D game, rounded up. Using this guideline, a level 36 D&D game wizard is equivalent to a level 28 arch-mage in the AD&D game.

Access from the Northern Reaches to other campaign worlds is possible through Yggdrasil, the World Ash (see page 63), an Outer Plane with numerous gates to other worlds. Adventurers can reach Yggdrasil through the use of the clerical *travel* spell (in the D&D game) or plane shift or gate spell (in the AD&D game) or use of an artifact with similar powers. Such artifacts may be found as sacred cult treasures of any one of the various Northman cults, and may also be found in the treasure hoards of the Modrigrswerg.

From Yggdrasil, adventurers may come to the Sea of Moving Ice, enter the lands of the Moonshae Northmen (both of the **FORGOTTEN REALMS boxed set**), or to the Snow Barbarians (Kingdom of Schnai) of the **World of Greyhawk® boxed set**, or

any Norse culture in your own AD&D game campaign setting.

## Technical Changes and Equivalencies

Technical differences between the D&D game and the AD&D game are relatively trivial, but for those people unfamiliar with D&D game, here are a few details that need to be clarified. Topics appear in alphabetical order for easy reference.

**Alignments:** D&D game characters have only three alignments — *Lawful*, *Neutral*, or *Chaotic*. For the AD&D game, assign *Good*, *Evil*, or *Neutral* alignments, depending on the context.

**Classes:** In the D&D game, elves, dwarves, and halflings actually are character classes. D&D game elves correspond to AD&D game elven fighter/magic users. D&D game dwarves and halflings are fighters. At high levels, D&D game demi-humans use *Attack Ranks*, which reflect their abilities to fight better. Ignore these in AD&D game. Human fighters, clerics, magic users, and thieves are unchanged.

**Coins (cn):** The “cn” abbreviation stands for “coin” and is a measure of weight equal to the AD&D game “gp.”

**Dominions:** These are lands under a character's rule, like AD&D game baronies. Rulers receive taxes from inhabitants, as well as income from natural resources and services. D&D game dominion populations grow an average 15% per month—5d10 persons. At 50 inhabitants per square mile, the growth tops out at 1d5% - 5d10 persons. Use AD&D game *Taxation*.

**Equipment:** Terminology in the D&D game is very similar to AD&D game. Equipment cost, encumbrance, damage in combat, or AC protection may be slightly different; when in doubt, check AD&D game references.

**Encumbrance:** See cn or coins.

**Experience:** Total accumulated experience for character classes may differ in the two systems, but not enough to affect play significantly. There's still an obvious difference between a level 1 magic user and a level 15 wizard!

**Immortals:** Equivalent to AD&D game deities, these powerful beings often are

NPCs who reached level 36 and completed a heroic quest to qualify as Immortals.

**Morale:** Whenever NPCs or monsters are seriously threatened, especially during combat, they may surrender or flee if they fail a morale check. For AD&D game, use the reaction/loyalty systems.

**Monsters:** Some D&D game monsters do not exist in AD&D game. Replace them with similar AD&D game creatures, or adapt the D&D game creature using a similar AD&D game creature as a model. Stats and abilities of a given creature may differ between the two systems; when in doubt, check the AD&D game **Monster Manuals**.

**Movement:** Movement rates in D&D game are given in feet/turn and then, in parentheses, in feet/round. In D&D game, 100'/turn equals 10'/round in AD&D game.

**Ranges:** All distances are expressed in feet, rather than in inches. Assume 10' are equivalent to 1" in AD&D game. Use AD&D game ranges for missile weapons and spell casting.

**Rounds:** Rounds and turns are used the same way in both games. D&D game does not use segments. A D&D game round equals one minute; a D&D game turn equals 60 rounds. For simplicity, use AD&D game equivalents without converting.

**Spells:** Some D&D game spells have slightly different names than their AD&D game counterparts. Modify the number of memorized spells per spellcaster character level to match AD&D game rules. AD&D game spellcasters have many spells not available to D&D game spellcasters. Adapt NPC spellcaster strategies to take advantage of AD&D game spells.

**War Machine:** This D&D game mass combat system has no AD&D game counterpart. “BR” stands for Battle Rating and is used only with the War Machine system. We suggest the **BATTLESYSTEM™** Fantasy Combat Supplement which handles mass combat for both systems.

**Weapon Mastery:** Ignore references to D&D game weapon mastery and proficiency; replace with the AD&D game equivalent.

Scale: ONE hex = 1/2 mile

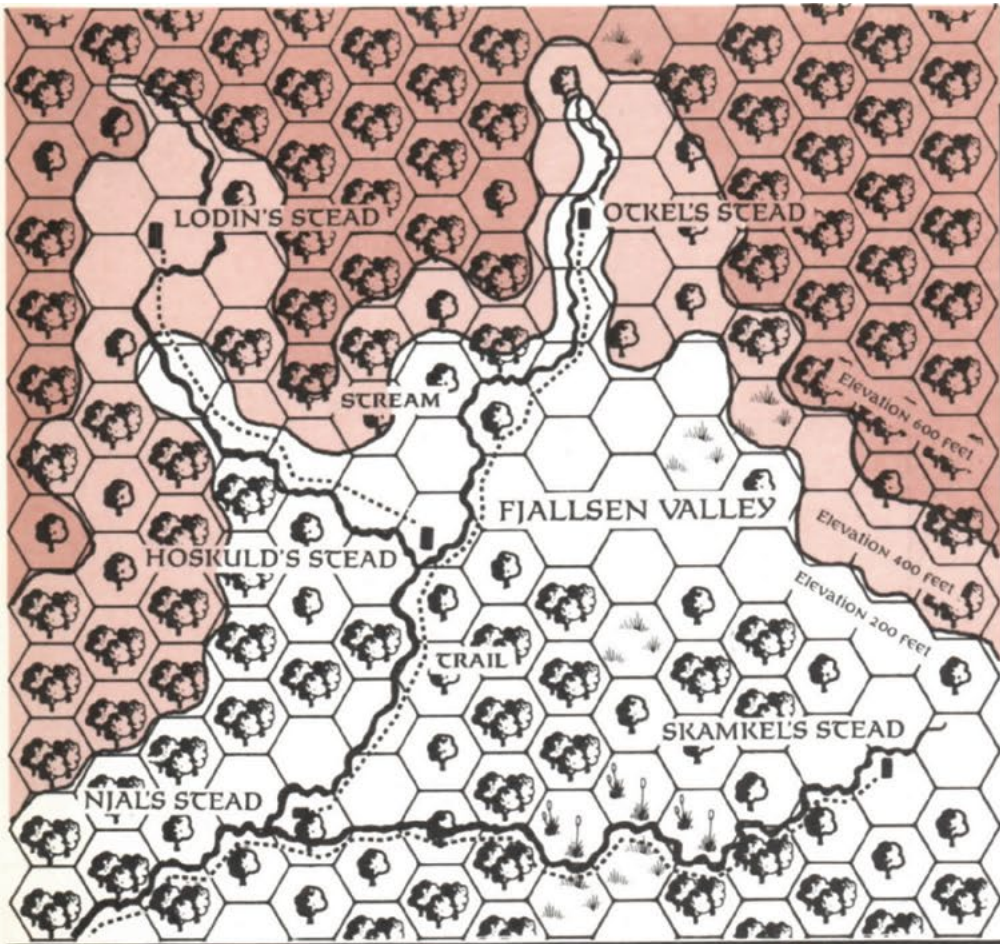

**The Court of Cnute at Zeaburg**

1. The Royal Compound
2. Great Hall
3. Queen's Court
4. King's Hall
5. Queen's Hall
6. Barracks of the Brothers of the King
7. Temple of Odin
8. Thralls' Quarters

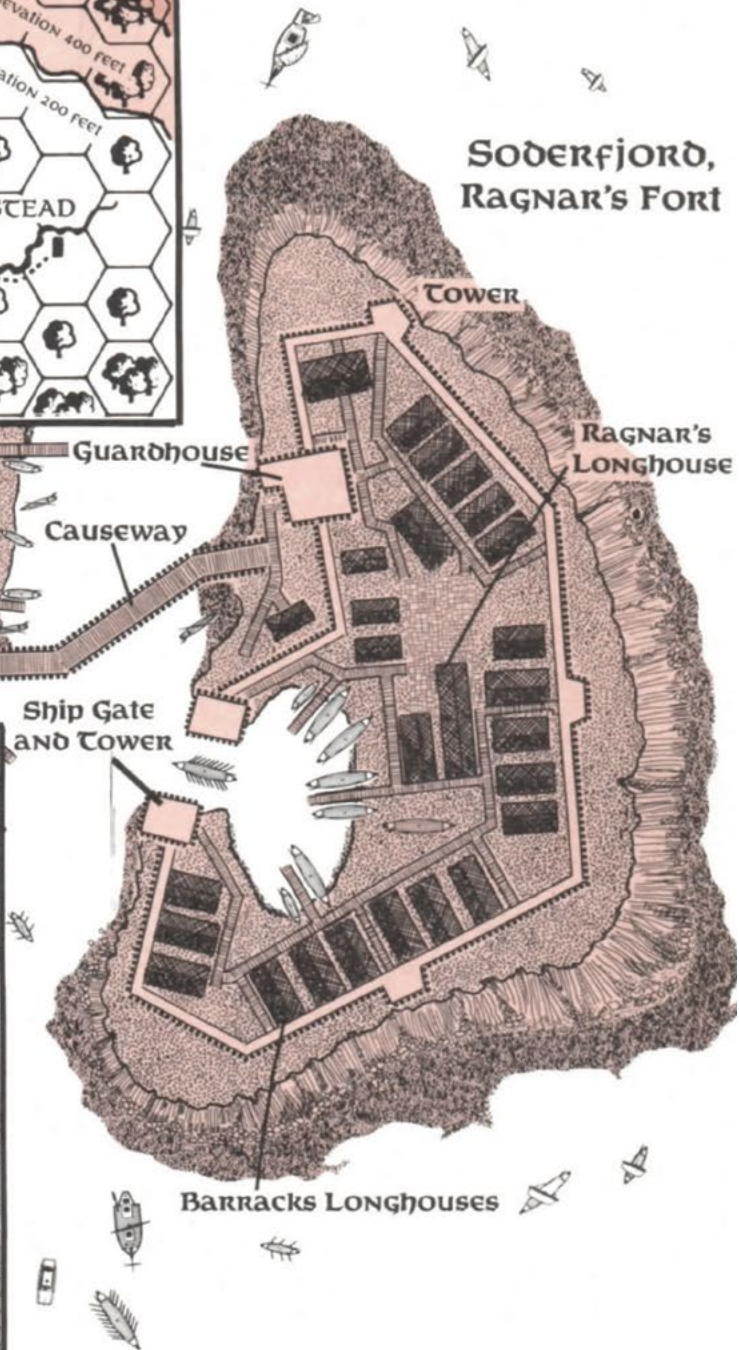
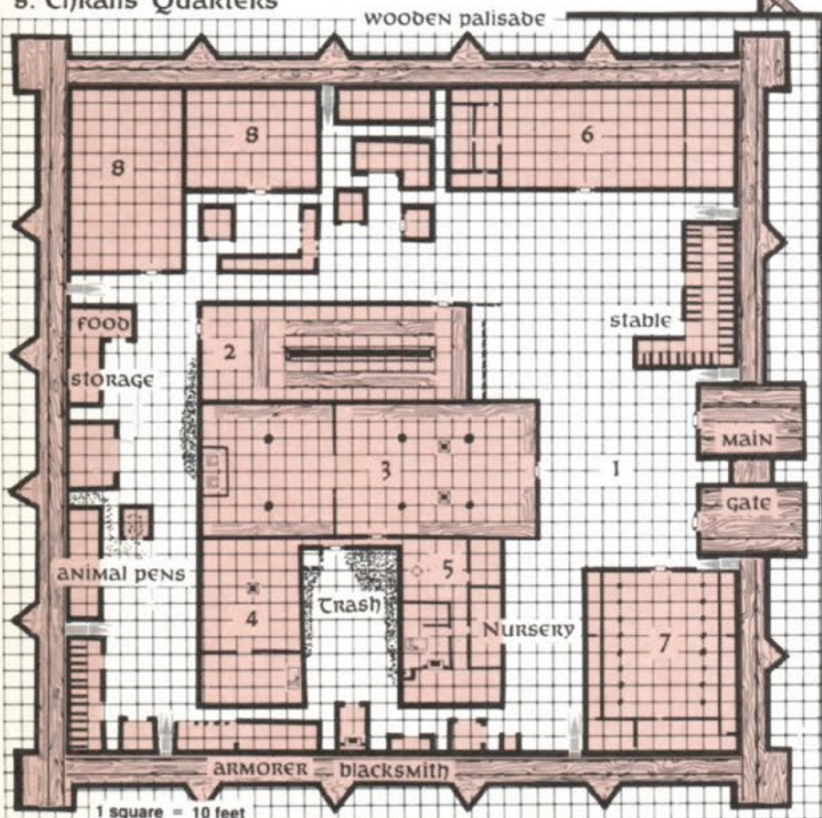

# GAZETTEER

OFFICIAL GAME ACCESSORY

## The Northern Reaches

by Ken Rolston and Elizabeth Danforth

### Table of Contents

#### DM BOOK

Introduction	2
History of the Northern Reaches	4
Geography of the Northern Reaches	7
Nations of the Northern Reaches	9
Ostland	9
Vestland	14
The Soderfjord Jarldoms	18
Non-Human Races	23
Court of Cnute	32
Adventures	37
Falun Caverns	37
Otkel's Stead	47
The Jarl's Hall	57
Campaign Notes	60
Adapting Gazetteers to AD&D® Campaigns	64

#### PLAYERS BOOK

What Everyone Knows	1
Northlands Society	4
Creating Northman Player Characters	9
Clerics in the Northern Reaches	24
Power Runes	29
Falun Caverns Player Map	32

#### Credits:

Design: Ken Rolston, Elizabeth Danforth  
Editing: Elizabeth Danforth  
Product Manager: Bruce Heard  
Coordinators: Karen S. Boomgarden, Bruce Heard  
Cover Artist: Clyde Caldwell  
Interior Artist: Stephen Fabian  
Graphic Design: Stephanie Tabat  
Cartography: Dave Sutherland, Dennis Kauth  
Typography: Kim Janke and Betty Elmore  
Playtesters: Mike Doolittle, Dick Garner, Anna Harmaty,  
George Johnson, Paul Rini, Dave Stephens, Martin  
Wixted, Mark O'Green

AD&D, DUNGEONS & DRAGONS, D&D, FORGOTTEN REALMS, WORLD OF GREYHAWK, and BATTLESYSTEM are registered trademarks owned by TSR, Inc.

PRODUCTS OF YOUR IMAGINATION and the TSR logo are trademarks owned by TSR, Inc.

Distributed to the book trade in the United States by Random House, Inc., and in Canada by Random House of Canada, Ltd. Distributed to the toy and hobby trade by regional distributors. Distributed in the United Kingdom by TSR UK Ltd.

This module is protected under the copyright laws of the United States of America. Any reproduction or other unauthorized use of the written material or artwork herein is prohibited without the express written permission of TSR, Inc.

©1988 TSR, Inc. All Rights Reserved. Printed in U.S.A.

TSR Inc.  
POB 756  
Lake Geneva,  
WI 53147 USA



TSR UK Ltd.  
The Mill, Rathmore Road  
Cambridge CB14AD  
United Kingdom

ISBN 0-88038-573-1

9230

# What EVERYONE KNOWS...

## About the Kingdom of Ostland

as told by Onund Tolundmire, priest of Odin, runemaster and skald, a native of Ostland

**The People:** "We are a great nation, prosperous, powerful and proud. Our people have always been masters of raiding and warfare. A sword is as natural to the hand of a farmer as is the plow. Our king springs from a line of great warrior-kings, and his jarls and their men are without peer in courage and might of arms. Our nation is blessed by Odin and Thor. None can question our glory and honor, and none shall stand against us in battle."

"Others call us violent and brutal, and condemn our right to raid and make slaves of those who war against us. These are the craven cawings of the weak. None shall win power or glory without strength and determined will."

"Others call us primitive barbarians, and scorn our respect for the old ways. We are doubtful of the honor of 'civilized' men. We do not aspire to be fat merchants or scribbling clerks."

**The Land:** "The wind blows endlessly, and there are precious few hills and forests to break its force. In winter, the fury of the ocean storms is terrible to bear. Yet, our other seasons are moderate, the growing seasons long, and the land fertile and generous. The main island is thoroughly settled. Folk generally live in large villages and clan settlements, close to their kin, and most of the land is well-cultivated. The other islands are wilder and more sparsely populated."

**Zeaburg:** "Our capital is an ancient clan seat, the court of the High King Hord Dark-Eye, and the winter quarters for the twenty Great Houses of Ostland. Zeaburg is not like your dark stone cities—it's more a scatter of friendly villages close together. In the center lies Hord's Royal Compound, a great fortress, and center of culture and hospitality among the Ostland folk. Outlander visitors can be too disruptive, and they must keep to the the Foreigners' Compound."

**Other Towns:** "The fortresses of

Zeaburg house the two brigades of King Hord's standing army. Ostmanhaven is a fishing and trading town, perhaps more modern and, I think, more corrupt than most Ostland towns. Thorir the Wealthy, jarl in Ostmanhaven, sets a bad example."

**How to Get Rich and Famous:** "Join the service of some great jarl or, better yet, join the service of the king himself. Sail with the raiders. The king's armies are fighting in the local squabbles between Thyatis and Alphatia, and there is much glory to be won. Join a colonizing expedition to the Isle of Dawn or go on to more distant shores."

**Hot Tips:** "Don't look for taverns or inns—there are none. In Ostland, you're either family, a guest, or an enemy. Because it is the heart of the nation, Zeaburg treats foreigners a little differently, but ask for hospitality elsewhere in the islands, and you'll not be denied. Treat your host generously and honorably, and you'll be well-treated in turn."

"In Ostland, we do not mock the Immortals or the ancient traditions, and a traveler is advised to respect that, be he Northman or dwarf, warrior or cleric of some other god. Ostlanders are a proud and proper folk, and we do not tolerate disrespect for the faiths or observances of our fathers."

## About The Kingdom of Vestland

according to Dwalinn the Dwarf, adventurer, philosopher, and tavern lout, native of Vestland

**The People:** "For good or ill, Vestland is what they call a 'modern nation.' In towns along the coast, most buildings are stone—dwarf work, most like—and the

people don't gawk like you're a prince when you show a silver coin."

"Course, up north in the hills and out west to the mountains, things are a lot less civilized. Folk there tend to stick to the old ways, boast proudly of their muddy little huts, and fancy themselves as old style warriors and heroes from the sagas. Real bunch of hayseeds."

**The Land:** "I prefer the rugged foothills along the southwest border—wild, beautiful country. But there's something to be said for Vestland's fjords, with their fertile lowland farms and steep valley sides leading up to the rocky plateau land. There's some excellent farmland along the coast, I'm told, but inland's no good for anyone but the sheep. The Trollheim hills—well, they have their own beauty, I guess—bare granite tors and wild, wet marshlands. It's no place for sightseeing, though."

**Norrvik:** "A real, honest-to-Odin city, high on the bluffs over the river. The Market Square district's pretty fine if you're out to blow your money. I prefer the College District. Good folk and quiet, and those charming, worthless students. Students? As the locals brag, they're studying at the only magic college in the Northlands. Now the Docks are another thing: dirty, cheap, but never dull. I stay out of Dwarfstown—no fond memories of my childhood there. It's a rough place, not cheerful."

**Other Towns:** "Rhoona's busy, filthy, a frontier town full of dwarves, merchants, adventurers, and hunters of giants. Rough town, but lots of loose money and plenty of excitement. Landersfjord? Big and getting bigger, right on the Overland Trade Route, with ships heading west and east. Plenty of work with caravans and expeditions."

©1988 TSR, Inc. All Rights Reserved. Printed in U.S.A.

DUNGEONS & DRAGONS and D&D are registered trademarks owned by TSR, Inc. PRODUCTS OF YOUR IMAGINATION and the TSR logo are trademarks owned by TSR, Inc. Distributed to the book trade in the United States by Random House, Inc., and in Canada by Random House of Canada, Ltd. Distributed to the toy and hobby trade by regional distributors. Distributed in the United Kingdom by TSR UK Ltd.

This module is protected under the copyright laws of the United States of America. Any reproduction or other unauthorized use of the written material or artwork herein is prohibited without the express written permission of TSR, Inc.

## What EVERYONE KNOWS...



**How to Get Rich and Famous:** "Hunt giants and their kin. Join a mercenary band and fight in the Troll Border Wars, or ride the highways with the Home Guard. Join the treasure hunters looking for lost artifacts of the molder dwarves. The pay for caravan guards is pretty good, but you earn every copper."

**Hot Tips:** "Watch out for dwarf-haters—every little frontier hamlet has its frothing bigots. Don't believe that cheery crap the Council's spreading about peace and prosperity in the Trollheim colonies; things are bad up there, and no mistake. And those hill giants are big! and not as stupid as the stories say. Don't get cocky."

### About The Soderfjord Jarldoms

*as told by Helfdan Half troll, warrior and roughneck, native of the Jarldoms*

**The People:** "Yeah, the Jarldoms are kinda backward, I guess. You won't find more friendly folk than our farmers and

steaders, but the poor folk don't get much peace, what with the clans all squabblin' with each other, and the bullies that the jarls hire for their guards. Every little headman thinks he's the High King, an' he lords it over his people even though they're all living in mud huts, from the headman on down. Sure, some clanholds are better than others, but it's no pleasure to travel among 'em. They offer their hospitality, but you've got to eat their dirt thanking 'em for it, they figure they done you such a favor.

"And fighters? Well, we're a loud and rash lot, but not too bad in a fight. Problem is, it's each man for himself. No one can tell nobody else what to do. No wonder the Ostlanders push us around like nithlings.

"Me, I like the frontier. No big jarls or clans out there, just roughnecks and frontier folk, the hunters, trappers, adventurers. Sure it's rough, but a man's respected for his own worth, not his father's or his clan's name."

**The Land:** "Good farmland along the coast and along the Saltfjord and Oto-

fjord. There's good farming in the Snowvale Valley north of Castellan, too, I hear. Now inland, it's all rocky plateau. A farmer'd never prosper there, nothin' but grass grows, and that just in between the rocks and boulders. The Great Marsh? Wet and wild, they say, but good for hunting. The foothills of the Makkres Mountains to the west are pretty bare, but there's little trouble with humanoids there. The hills of Gnollheim—well, that's big trouble these days. Rough country, and thick with gnoll war bands. Finally, there's the Hardanger Range in the south. That's nothing but jagged peaks, glaciers, and kobolds."

**Soderfjord Beach:** "Compared to Norrvik, it's pretty mean and muddy, though I think it's right lively. Merchants and traders a-plenty, from all over. You can get what you need there, and lots of stuff you don't, but it's not a real nice place. Ragnar's the war leader, and his fortress out in the river is something to see, big thing and real 'mpressive, it is."

**Other Towns:** "Castellan is a pretty little town, mostly stone. It's a big trading

center, and there's lots of furriners—elves, Ylari, dwarves, and such like. Lots of outfitters, too, if you've a mind to go trekkin' 'round the backwoods."

**How to Get Rich and Famous:** "Hire out as a bully for a jarl—or beat up bullies and rob them. You can go pirate raiding, like the Ostlanders do, by finding a captain—ask around. Or buy your own longship, and you captain it. Guarding caravans is good pay, and it keeps you away from the clan bullies. Oh, there's mountains of treasure in the Hardangers, they say, down in those old gnome holes, but those holes've got lotsa dogmen, too. Ragnar's got gold to pay for mercenaries to guard the borderland and caravans against raiding humanoid. Lots o' that kind of work, state and private, down by the Sodervirk—that wall on the Gnollheim border."

**Hot Tips:** "Stay clear of clan squabbles, unless you hope to make money on the winner. Don't push your luck with clanheads or their bullies. The jarls are the law in Soderfjord. If they don't like you, they can chop your head off, an' it's twice as easy if you're not protected by your kin in some other clan. Don't trust nobody rich or powerful—you're just a pawn to 'em."

## AN Outsider's Perspective ON THE Northern Reaches

*from Saru the Serpent, sorcerer and scholar, and itinerant citizen of the whole of the Known World*

**Contrasting the Three Nations:** "Ostland clings to tradition, while Vestland struggles to be a modern nation. Soderfjord lies somewhere between. Many folk in the Jarldoms still hold firmly to the Northman values, but small, influential groups—particularly the merchant class in the growing towns—want to see Soderfjord a modern trading nation like Vestland. Their money buys influence and political power, so the traditionalists cannot ignore them."

"Ostland is a barbarian culture, with an emphasis on the warrior virtues, where a leader must defend his authority through

personal strength of arms. Vestland is a more modern nation, where the authority of the law, rather than personal strength of arms, protects its citizens.

"Soderfjord is a young nation in transition from the older barbarian ways like Ostland's, to a more modern culture like Vestland's. In Soderfjord, the larger the town, the more modern the local values. Conversely, the more remote the place, the more traditional and barbaric the people will be.

"Yet even in Soderfjord's current turbulent political climate, it's possible to see in the growing power of the war leader, Ragnar. Every year he looks more capable of unifying the Jarldoms into a nation like Vestland. Unfortunately, there are many other nations—particularly Ostland, Ylaruam, Ethengar, and Thyatis—that prefer to preserve the current political chaos in the Jarldoms."

**Prospects for Adventurers:** "In general, look to the borders and wildernesses. Vestland and the Jarldoms seek expansion into the wild hills and mountains that surround the nation to the north, west, and south. The humanoid and giantish races must be controlled or removed, and a wealth of plunder may be gained.

"Ostland has no wilderness left. It seeks new land across the ocean to the southeast on the Isle of Dawn. As Ostland cements its ties with Thyatis, perhaps the nation will expand to the north into Norwold."

**Prospects for Crusaders:** "Do-gooders will find plenty of work in Soderfjord, where the common folk are often caught between feuding clan nobles. Enemies of Chaos may contend with the troll nations to the north, the giantish races to the west, and the growing armies of the kobolds in the Hardanger Range.

"One problem for the thoughtful crusader: the warlike and violent cultures of the Northern Reaches have produced a people who accept brute force as a standard tool of rulership. Crusaders from more peace-loving cultures must be careful before they judge actions as 'evil' or 'chaotic.'"

## Comparing Traditional Northland Virtues with Modern Civilized Notions -

*Helfdan and Saru examine the differences*

**Helfdan:** "These scribblers and fops, why do Vestlanders put up with them? I step from my ship in Dremmen Harbor, and this pipsqueak in fancy dress comes up, jabs me in the stomach! Says, 'Customs and Immigration. Where's your cargo list?' I grabbed his dinky pink fist, jammed his pen into his palm, and told the little runt what he could do with the cargo list if he ever found it..."

**Saru:** "...and, in fact, I believe our friend Helfdan might have killed the fellow had we not intervened. You see, Helfdan and other champions of ancient Northland virtues feel that a man has no authority unless he can back it up with his fist. The notion of Vestland government officials making demands on manly warriors... well, it often leads to fatal misunderstandings.

"In Vestland, a government official feels safe from physical threats because of the strength of the law and the Home Guard. Helfdan had some trouble there, I'm afraid, and we had to smooth a few ruffled feathers."

**Helfdan:** "Pipsqueak. Fines weren't much after I had a good roar at the fellow."

**Saru:** "Now in Soderfjord, a local official needn't be a warrior to collect a jarl's tribute, but he is wise to accompany himself with a band of persuasive-looking thugs. In Ostland, everything is a personal matter. The king himself, traveling with the Personal Guard, come to his jarls to collect the tribute. And, in turn, the jarls go personally among their freemen to collect their tribute. In Ostland, a man does not make demands he cannot personally back up with force, and it is not considered improper to thrash someone for impudent behavior."

# Northlands Society

## The Northern Temperament

as told by *Saru the Serpent*

“What’s the Northman like?” you ask.

“Well, foremost, a Northman is loyal—loyal to his family, to his clan, and to his friends. A man who honors these bonds and their obligations is well-respected. A man who turns his back on his family, clan, or friends is a scoundrel. A man who allows others to speak ill of family, clan, or friends is a coward.

“The Northlander values hospitality and generosity. The customs concerning a host’s duty are detailed and well-established in the Northern Reaches: to welcome, shelter, and protect guests. The guest has a reciprocal obligation to honor and defend the host, without pausing to examine right or wrong. Wealth in itself is not a virtue. A man who gains wealth by being stingy is not respected or trusted, which explains the Northman’s scorn and distrust of merchants.

“All Northlanders honor courage, and scorn weak-willed men. This is not only the courage of war, though that is most important, and quickest to mind for most. It also includes courage to face hardship and misfortune, to accept one’s fate as assigned by the Immortals, and to remain cheerful and content even in great pain or privation. It is dishonorable to complain of bad luck, or to whine about impossible odds.

“In fact, Northerners greatly appreciate wit and jokes when the prospect is bleakest. I saw Helfdan here just when we were outnumbered ten to one. ‘Ho-hum,’ he said. ‘I’d hoped for something more exciting. Hate to get this nice floor all awash with their blood, but I don’t think they just wanna play tag with us!’

“Forgiveness is not considered a virtue in the North. The Northman is slow to forget an insult or injury, particularly where the injury affects a friend or family or clan member. Northmen look upon cruel and ruthless pursuit of vengeance as simply the most effective method of insuring that everyone behaves himself properly or faces the consequences. On

the other hand, law and tradition require that vengeance be forgotten if wergild is paid—wergild being a mutually agreed-upon payment made in compensation for the injury.

“The Northman prefers impulsive action over cautious deliberation, and quickly grows impatient with long discussions. Some say it is because the Northman believes his fate is already determined by the Immortals. Others say it is because the Northmen are a ferocious, warlike people obsessed by courage rather than reflection. Others say it is because the Northlander is quick-witted and clever at improvisation in the face of danger. There’s considerable truth in each of these views.

“I do not see the average Northman as particularly respectful or reverent of the Immortals. There are many traditionalists, of course, especially in Ostland and the backwoods of the other lands. And clerics, of course, are more dedicated. But the modern ‘civilized’ Northman thinks little of the gods or how to please them. Certain fighters, particularly the berserkers, appear to serve their Immortals energetically but, in truth, I think such folk are more dedicated to the fun of fighting than to the Immortals themselves. It is no disgrace in the cities, at least, to deny the gods—a godless man is not particularly respected, but neither is he scorned.

“Neither are Northmen what I call honest. They are loyal to their word, yes: if they swear an oath, they are honor-bound to respect it. On the other hand, shrewd or clever speech is considered perfectly fair, and misleading by omission or misdirection is not considered wrong or dishonest.

“Thus, when a Northlander gives his word, you are expected to trust him. Otherwise, the listener is expected to be suspicious, and to require proof in doubtful circumstances.

“Now boasting—boasting is not considered a fault. A certain amount of exaggeration is acceptable, particularly if it enhances the story. Idle boasting, or claiming honors to which one has no claim, is considered foolish, and a proper

occasion for a lesson in manners.”

## The Northland Lifestyle

as told by *Onund Tolundmire*

“Most Northmen are farmers and herders. In the good low-lying farmland, the folk gather in small villages. On the plateau and on the borderlands they live in isolated farmsteads, often fortified against humanoid attackers and clan raiders. The common people raise grain and vegetables, often with enough surplus to sell or trade at local markets. They raise livestock for meat, milk, and wool.

“Nobles and clan guards live in great timbered longhouses, forty to a hundred foot long. Freeman farmers and craftsmen live in smaller houses and huts. They dig below ground level to level their floors. This gives them deep foundations for the walls, and helps to protect the steads and their animals from cold weather.

“The walls are made of logs, planks, or wattle-and-daub, and the high, thatched roofs are supported by thick timber pillars. Hearthfires burn for heat and cooking. Family and guests sleep wrapped in warm furs on sleeping benches along the walls, and not shut away from each other like they do in the south.

“The Northman is self-reliant, and well-rounded in many skills. The farmer can take up the sword or tend a forge as easily as he guides the plow or shears his sheep. Even the soft city folk are less helpless than most civilized folk, and are often no stranger to shield and spear.

“In the warm summers and cool spring and fall, the Northman enjoys working hard outdoors, and takes great pleasure in hunting or weapons-play for leisure. In the harsh, brutal winters, he invites his livestock into his house, for their protection and for his warmth. He barely stirs for months, hibernating like the great bear waiting for spring.

“Life in the larger settlements is scarcely different, though many more men specialize in crafts, and merchants and traders buy their products and sell them throughout the Northern Reaches.



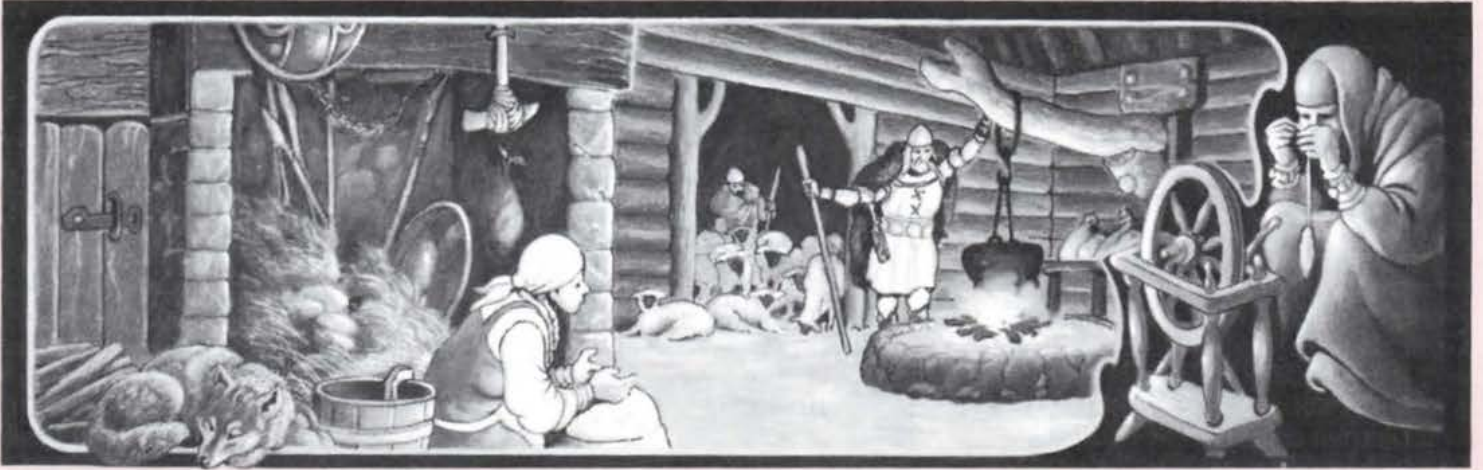

Only in cities like Norrvik and other large Vestland towns do folk live in stone houses along cobbled streets according to southern fashion. Here the nobles and the newly rich middle-class style themselves after the decadent dukes of Karamaikos and Thyatis, forsaking the strict and honest ways of their ancestors.

"The Northmen are renowned sailors and shipbuilders, and their longships range the coasts of the Known World. World travelers, colonizers, and adventurers, the Northmen are fearless and wide-ranging traders. Some call us pirates—perhaps with some justice, but are not all merchants really pirates at heart? The only question is whether they reap their wealth with a sword or with a sharp, lying tongue!"

## Social Classes of the North

*as told by Saru the Serpent*

"The jarls are the noble class of the Northern Reaches. These aristocratic families are the hereditary rulers of the clans. The clanhead is generally the most noted adult of the most powerful family within the clan, and the heads of other family households form the clanhead's house guard, the equivalent of feudal household knights. When a clanhead grows old and feeble, he usually yields his crown or is deposed, and his most suitable offspring or close relative, male or female—not necessarily the oldest child—is chosen as the new ruler. Since

jarls often inherit great treasures handed down for many generations, and they receive the lion's share of booty taken in war or raiding, many noble families are quite wealthy.

"The karls are the freemen of the Northern Reaches. Karls generally fall into two sub-classes, the common freeman and the merchant middle-class.

"The vast majority of Northland citizens are common freemen, from farmer to craftsman to town-dweller. Northman freemen are relatively well-off compared to other freemen throughout the world. They owe allegiance to their clanheads, but they own their own land, homes, livestock, and may decide their own means of livelihood.

"The merchant middle-class is relatively small and often fairly wealthy. Ostland has no such class, while the power and influence of this class is growing rapidly in Vestland, less dramatically so in the Jarldoms.

"The thrall is literally a slave, the property of his owner, to do with as he chooses. Only in Ostland is slavery still legal. Prisoners of war or raiding become the thralls of their conquerors, or a jarl may condemn a freeman to thralldom for various offenses. Though theoretically illegal in the Jarldoms, many clans still practice slavery or its equivalent. Though thralldom is generally despised by foreigners, it must be noted that thralls are rarely treated harshly, and are often set free at the master's death as a reward for faithful service. In my travels, I have seen many supposedly free men throughout

the Known World who live more wretched lives than most Northman thralls.

"In addition to the three primary social classes of jarl, karl, and thrall, there are a number of other social roles peculiar to the Northman culture.

"The skald is a mixture of scholar, poet, entertainer, and moralist. These students of history and legend travel around the country, accepting the hospitality of a hearth for a time and, in return, they entertain, educate, and inform their hosts on events outside their region. Often the skalds are rune-literate or skilled with rune-magic. Tradition prohibits taking ready offense against a skald—they have a freedom of speech denied to others. Unless you are first attacked, never take up arms against such a one, though many skalds are themselves proficient in arms.

"Witches and wise women are the practitioners of the old, dark magics of the Northman's ancestors. In general their powers are modest, limited primarily to fortune-telling and clumsy hedge-wizardry. Now and then you'll come across one with considerable skill with charms, curses, conjuring, and shape-shifting.

"Northmen have little trust or respect for wizards. They seem to see us in the same light as they see merchants or lawyers: sneaky, evil-spirited, and dangerous, but timid and brittle-necked in combat. Priestly magic tricks are considered honorable and virtuous, but sorcerous stuff is cowardly and unsportsmanlike. These silly, primitive

## Northlands Society

notions are partially rooted in the Northlander's awed fear and distrust of witch-wizardry, I suspect. Still, I don't find it surprising that a Northerner prefers the mace-wielding, shield-bashing spirit of clerical spellcasting to the refined and subtle arts of thaumaturgy and enchantment. I imagine a wizard who wore chain mail and charged into battle howling, his axe raised on high, would suit the Northman better. You don't see many elves in the Northern Reaches, but I suspect their more violent tradition of spellcasting suits the Northlander's taste.

"Each of the major cults of the pantheon—Odin, Thor, and Frey/Freyja—has its priests, called *godar*. The *godar* are generally of three types. *Household godar* are attached to the household of the clanhead, or to the chosen headman of whatever the local community is. The *godar* serve and advise the rulers, and provide for the spiritual needs of the local people. *Monastic godar* live in groups apart from other communities, often at the site of some special shrine or location sacred to the cult. *Itinerant godar* are priests who travel from community to community to serve the faithful in remote regions, and also to serve as agents and defenders of their cult's interests.

"In addition to the house guard—the noble supporters of the clanhead—many clan rulers have something called the *Hird*, a group of freemen warriors of common birth who are sworn retainers of the jarl. In earlier times, the *Hird* was simply a skilled reserve force for the clan. In modern times, the *Hird* has become a small standing army of professional warriors in the service of the clanhead. Often enough, the jarl they serve gives the *Hird* a special name, as King Hord of Ostland has named his *Hird* the *Ravenguard*."

### RANK AND THE SOCIAL ORDER

as told by Saru the Serpent

"At the top of the social order is the High King. In ancient times there were many kings and many small kingdoms. In Ostland, the clanheads and their domin-

ions are still sometimes referred to as kings and kingdoms, though the title of jarl has become common for less formal occasions.

"However, ever since King Cnute Bear-chest, Ostland has been ruled by a High King, a king among kings. Vestland also has a High King, also a descendant of Cnute, but he shares his power with the Royal Council, becoming less of a monarch and more of a figurehead.

"Soderfjord has many chiefs who style themselves 'High King,' but none have the power to make good their claim. Ragnar the Stout, the war leader of that country, now enjoys some of the powers of a High King, though I think it unlikely that he will officially wear such a title in our lifetimes.

"Northmen think of themselves as a people, not as citizens of particular nations, at least not in the southern sense. Vestlanders are the exception in this regard, but even those in the borderlands regard themselves as clansmen first, and Vestlanders last. Ostlanders think in terms of their personal obligation to their ruler, rather than to their 'nation.' The Jarldoms are still too recently united as a nation to have developed any identity, and the political situation is too unstable to expect significant changes in the near future. The people of the Jarldoms still think in terms of the traditional chain of command: where one might fight one's brother, but brothers join together to fight cousins, who will lay aside arguments to fight together against other families, who will in turn join together against a separate clan.

"Loyalty to clan and clan chief is another important element in the Northman's sense of social identity, sometimes hard for an outsider to comprehend. The Northman owes allegiance to the clanhead, and expects protection and respect in return. At best, the relationship between clansman and clanhead is a personal and generous one; at worst, it is arbitrary and autocratic. One is expected to defend the clan and its reputation as a matter of personal honor.

"Loyalty to family and its patriarch or matriarch is also a potent obligation.

When the demands of the clan and family loyalties are in conflict, intense and tragic feuds result. The traditional obligation to family is the stronger, though the practical goals of power and ambition are more often served by clan loyalty.

"Certain individuals of the Northern Reaches are clanless: they might be of foreign birth, have renounced their clan ties to be free of impossible obligations, or they may have been outlawed for serious offenses. Clanless persons are viewed with suspicion and distrust. Those who wish to change their clanless status, or who wish to change clan allegiances, have little trouble doing so. Marriage between clans is quite common, even expected.

"Family loyalties run deep in the Northern Reaches. Northlanders are expected to respect and obey the head of their family, and to protect and generously aid their siblings and kin. One is expected to stand by one's family, often without regard to the right or wrong of the circumstances. As with the clan, adoption into a family is common. The practice of fosterage—sending an offspring to be raised by a close relative or friend—is another method of strengthening family and social ties.

"Friendship is also a sacred trust among Northmen. It is a great crime to abandon or betray a friend. The ritual of blood brotherhood, where light ceremonial wounds are brought together under a solemn oath, raises friendship to the status of a family bond."

### The Warrior's Code

as told by Helfdan Half-Troll

"I guess there's a touch of the hero of the sagas in all of us Northerners. Saru says it comes from all those stories our parents and the skalds tell us—stories about gods and giants and trolls, and heroes with magical spears, and about the Final Battle Ragnarok when all good Northmen will stand beside Father Odin to guard the Bridge of Heaven against the giants and the Queen of Hel.

"Well, I s'pose that's true enough. But a Northman has to know how to protect

himself, whether he's a jarl's guard or a farmer. With all them nasty monsters and raiders, it's smart to be handy with shield and spear. And we start young.

"When I was fourteen, I was made a house guard to Askold Ubbison, clanhead of Varmgard, a great jarl.

"House guard? Well, I guess it's like being a household knight to a duke or maybe to a prince in one of them southern nations like Karameikos.

"I spoke this oath, a shield oath, before my jarl and before my shield-brothers. Other Northern warriors speak some sort of oath like this when they join in a common cause. These are good words to live by—even for weaselly little dwarves like Dwalinn...

*"Honor thy lord, and avenge any injury upon him.*

*Honor thy word and oath.*

*Honor thy friend and fellow warrior, and desert him not in his need.*

*Honor the hospitality of thy host, and make no breach of the peace.*

*Honor the stranger, give him shelter and protection.*

*Honor thy name, and make no false pretense upon it.*

*Be fearless.*

*At the end, hope for death in battle, weapon in hand, the bodies of thy enemies heaped about thee."*

"Sure, I went raiding when I was a kid. It's a good way to get rich and make your reputation. I never hurt no women or children, and I never burnt no houses—well, 'cept once when we was gettin' even with some other pirates who'd come burning our houses. I killed some men, true, but I never tried to start a fight—and I never finished anybody off while he was down, the way those berserks do, when they get into a chopping fury.

"I don't go raiding no more. I get plenty of action adventuring and campaigning against the trolls and gnolls. I don't miss raiding. I kinda agree with Saru—things are getting too civilized around here to let that old-fashioned raiding go on. It ain't gonna stop, though, not as long as Hord Dark-Eye winks at his Ostlander jarls when they go out for loot.

"There's plenty of work in the Northlands for a fighting man. Now the Northman kings have their professional armies. Hord Dark-Eye's brigades get lots of action, and good pay, I hear, though I'm not too keen on being a Thyatian mercenary like what Dwalinn says the Ostland armies are, mercenaries for them Thyatians. And there's caravan guards and border riders in the outlands—now that's the work for me. Plenty of uglies out there, and poor homesteaders what need an honest warrior to protect 'em. And there's always treasure-hunting folks who need a strong arm and sharp wits to guide 'em to the uglies' lairs."

### Northland Law

*as told by Onund Tolundmire*

"The Northmen believe that once the facts of a case are made clear, a just judgement is obvious to any sane person. The right and duty of judgement belongs to the leader of the community, whether it is the king, a jarl, a village headman, or the captain of a raiding longship. Although it is the leader's right to judge, it is also his or her responsibility to give consideration to all testimonies of those concerned, and to weigh the advice of

acknowledged wise counselors—the clerics, elders, and wise women of the community, most often. Northmen do not trust written laws and they scorn 'civilized' notions of law and lawyers, which they believe to be elaborate schemes dreamed up by merchants and cowards to cheat and abuse honest men.

"When a man is accused of a crime, notice of the hearing is spread through the community, and the accused is brought before the community leader. In the search for truth, Odin's Ravens—specially-trained clerics of Odin—are summoned to cast the *detect lies* spell on the accused and on witnesses.

"Each community has ground sacred to Odin called the Place of Judgement. Here is a small shrine dedicated to Odin, often marked with runes for the use of Odin's Ravens. These runes have magical powers to help ensure peace during the trial.

"The leader listens to the evidence, then to comments and recommendations for judgement. He or she then retires to consider the case, usually for no more than an hour, but at times for days or even weeks. Then the leader returns and announces his judgement.



## Northlands Society

"Because of the vengeful Northern temperament, the most common sentence simply encourages the aggrieved party to take his vengeance on the evil-doer. Neither the judge nor the community necessarily owes any aid in enforcing a sentence, though it is common for the judge and the honest people of the community to side with the victim.

"Because vengeance can be so disruptive to the community, Northmen have evolved the concept of wergild—compensation paid for an injury. Essentially, the victim is offered a payment to abandon his vengeance against the evil-doer.

"The appropriate compensations for various injuries or crimes are established by tradition, though in extreme cases the judge may demand a particularly great or small compensation, according to circumstances. For example, the wergild for manslaying of a freeman is usually 500 gp; for a serious or crippling injury, the wergild might be 250 gp. In the case of the murdered noble, 10,000 gp might be demanded, and for the slaying of a king, 500,000 gp.

"In many cases, the accused's jarl may pay half of the wergild; at the same time, a jarl often demands half the victim's wergild. When you realize that the parties might never be able to make good their claim on the compensation money without the armed might of their jarls, such an arrangement makes sense.

"In certain cases of particularly contemptible crimes—kinslaying, betrayal of one's lord, murder of a cleric, or the like—a man may be outlawed. The common term for an outlaw is 'black sheep' or 'nameless man.' An outlaw is banished from a region—generally from the clan domain, but in some cases, from a group of domains or even a nation—and forbidden to return, even in death. The accusation of treason is a powerful weapon for a jarl, and many men have been banished from their communities for no greater crime than incurring their lord's enmity."

### Customs of the North

as told by Dwalinn the Dwarf

"Well, you wouldn't believe some of the quaint practices reported by travelers... and neither would I. I'll speak of what I've seen with my own eyes, or learned through bitter experience.

"Burials, for example, of some king or powerful jarl. The noble got a hollowed-out oak for his coffin, full of finest wools and furs, and they raised a mound of earth above him. They cut the slaves' throats and threw the bodies into the bogs, then followed that with barrels of treasure. Now that I didn't see, but the wise woman who told me could not have been lying, under the circumstances.

"I did see a jarl burned in a longship built just to be his funeral pyre. I watched his wife march right into the fire and sit next down on burning cushions next to her dead lord. Spooky. And this old hag, a wise woman, or as they call them the 'Angels of Death,' hovered around the pyre, jabbering nonsense and waving a wand covered with runes. They say the old kings were buried or burned in deep crypts, with hundreds of warriors slain to guard over the tombs as living dead. Real quaint, huh?

"Another thing—hostages. The Northmen are big for trading hostages. They figure if they have your brother or sister or a close friend, you'll never do anything for fear they'll croak the hostages. And it seems to work, most of the time, though sometimes the hostages are slain in cold blood, and then the vengeance is terrible to see.

"Hospitality. Outsiders find it hard to believe, but the Northman doesn't hesitate to ask a party of adventurers in to share his hearth and bread. And I've had my host—a man I'd never seen before—take up arms against a crowd of bullies who pursued me to his door. Partly it's the fearless courage of the freeman, and his confidence in his weapons. Partly, too, the one who violated the sanctity of hearth and hospitality would risk a terrible vengeance. Admittedly, things are not so nice down in Soderfjord, with all the clan warfare and political brouhaha... too much bad blood, now.

"The Northman blood feud is serious business. Don't get mixed up in it. I once

fell in with a man who I later found was pursued by three brothers who wanted his head for an affront to their sister. Fellow swore he was innocent, but these brothers chased us all over Vestland, ambushing us a couple times a week, until we got lucky and finished them off. Good thing they were stupid, 'cause they were sure enough persistent.

"Northmen have a nice dueling custom—it's called '*holmgang*.' What happens is two parties who have taken offense with one another will put down a cloth about fifteen feet on a side, then drive stakes at the four corners and tie a rope around the area. Then the two men have at each other inside. Any man who touches one of the ropes or steps out of the area is a coward.

"I've seen it run two ways. One is a 'fight to first blood'—the first man to bleed on the cloth is the loser. The other is 'fight until one can't continue.' The two fight until one is unconscious or otherwise incapacitated, usually only with a priest about to keep them both honest. No magic, no magical weapons, just warriors and weapons.

"Northmen love boasting contests. Seems their fussiness about sworn oaths disappears when they start spinning a yarn. Folk take it none amiss when you wildly exaggerate your adventures and accomplishments, particularly around the hearth or when chewing a few flagons down at the tap. They don't like being lied to at all, but you can tell by their attitude whether they expect the straight truth or a rousing epic.

"And drink? Look, I'm a dwarf, and dwarves are no slouches at drinking, but I'm usually legless while those big Northlander clowns are still prancing around with two mugs in each fist. It's an important sign of strong character to be the last man to fall over at a feast or drinking contest. I'm not complaining, no... they do make a passable lager. Stay away from that mead stuff, though. It's fermented honey, sweet as can be. You can drink a tank of it and never even notice you've died. But the headache the morning after? Even a *cure serious* won't touch it."

# Creating Northman Player Characters

## Character Creation

Before you create a character from the Northlands, read through the entire Player Book. Knowledge of the special rules and abilities described may influence your choices in character creation. Be sure to consult with your DM. He or she may prefer that you use the simpler character creation system from the *D&D® Basic Player Book*.

Use the following procedures to create a beginning character from the Northlands. DMs may also use this procedure to create fully realized NPC characters.

**Choosing Character Race:** Neither elves nor halflings are common characters in the Northern Reaches. Check with your DM; he or she may prefer that you play human or dwarven characters.

### Step One: Create the Basic Character

Follow the procedures in "Making Up a New Character," *D&D® Basic Player Book*, pages 48-51. Choose your alignment, as section 9 says, but wait to choose your

name until you reach Step Seven below. (Steps Two through Six should give you an idea what your character is like, which will help you pick an appropriate name.)

### Step Two (Optional): Determine Personality Traits

Follow the procedure described in the section "Personality Traits" below.

### Step Three: Determine Nationality, Clan, and Home Domain

Consult with your DM. He may assign your nationality, clan, and home domain, or allow you to choose them. If you are allowed to choose, see the charts on pages 13 and 14.

### Step Four: Determine Training Background and Beginning Skills

To determine the experiences and skills learned by your character before he became an adventurer, use the Training Background Table. If your character has

an Intelligence bonus, select your bonus beginning skills. Record your character's background and beginning skills.

### Step Five: Determine Social Class and Family Status

Use the Social Class and Family Status Tables, page 20. Record your social class and family status. Make a note of your Heyday gifts, and note any Charisma bonuses or penalties in parentheses next to your Charisma ability score.

### Step Six (Optional): Determine Important Past Experiences

Use the four tables on pages 20-22 to discover important biographical details that may affect your character's abilities or possessions. Some of these details may affect previously-determined characteristics; adjust as necessary.

### Step Seven: Choose a Name

Select a name for your character. See the list of suggested names and the accompanying notes on page 23.

## Personality Traits (Optional)

Personality traits are a way of establishing a character's individuality, and help decide how a character would act in certain situations. Use of these traits scores is *optional* and should not be used to restrict the actions of a player character.

A player simply chooses his first-level character's initial trait scores when he creates his character. The DM may roll character trait scores for NPCs, or may assign them at will.

When an NPC is confronted with a situation where his personality traits might affect his actions, the DM may make a trait check to decide how the NPC will behave. When making a trait check, the DM rolls a twenty-sided die. If the roll is equal to or lower than the trait score, the NPC's actions are strongly influenced by that trait. If the roll is greater than the trait score, the NPC's actions are more strongly influenced by the opposite of the character trait.

Sometimes two or more traits may influence a decision. In that case, trait checks are made for each relevant trait, and the highest successful check determines which trait more strongly influences the NPC's actions.

For a player character, personality trait scores are an easily referenced summary of a character's personality. You can use trait checks to help decide how your player character might act in a puzzling or confusing situation, although they should be used with caution. *The traits are optional for PCs, serving only as reminders of distinctive characteristics.* The personality traits are not to be used as rules which DMs may apply to force player characters to act in any way other than the way their player chooses to have them behave.

Review the list of traits in the chart on page 10. Next to each trait is a blank line where the trait score is recorded. In parentheses to the right of the trait score is the opposite trait; the opposite trait determines a character's actions when he *fails* a trait check.

**Example #1:** Buri the Butcher and Ari Least-Wit are two NPC creeps. They poke their heads into a side passage and are surprised by two PC fighters and a PC magic user. Buri's Courageous Trait is 18. Ari's Courageous Trait is 7. Since they are surprised, the DM makes Courage checks for both NPCs.

Buri rolls a 14 and passes his check. "Who's a-scared of a puny hedge-wizard and his scrawny pals?" he sneers.

Ari rolls a 9 and fails his check. His actions are influenced by the opposite of the Courageous trait—Fearful. He recalls the last time he got toasted by a puny hedge-wizard. "Uh-uh-uh-YAH!!!"—and Ari beats a hasty, disorderly retreat.

**Example #2:** Onund Tolundmire, a player character, is walking along a trail when he encounters an old crone sitting by her hut, stirring something in a cauldron. The crone invites Onund to share a bowl of soup with her.

Onund is normally a trusting soul (Trusting 13), but he is also wary of stran-

## CREATING NORTHMAN PLAYER CHARACTERS

### Personality Traits Chart ALIGNMENT INITIAL TRAITS

Lawful: 12 + d6  
Neutral: 6 + d6  
Chaotic: 2d6

#### Traits

Cautious _____	(Rash)
Modest _____	(Proud)
Peaceful _____	(Violent)
Generous _____	(Greedy)
Courageous _____	(Fearful)
Reverent _____	(Godless)
Forgiving _____	(Vengeful)
Energetic _____	(Lazy)
Honest _____	(Deceitful)
Trusting _____	(Suspicious)
Loyal _____	(Unreliable)
Dogmatic _____	(Open-Minded)

#### National Modifiers

**Karameikos:** *no modifiers*  
**Ylaruam:** +2 Reverent, -1 Modest,  
-1 Forgiving, +1 Dogmatic  
**Glantri:** -3 Reverent, -2 Dogmatic  
**Ierendi:** +2 Trusting, -2 Energetic,  
+1 Generous  
**Rockhome:** *see below, under Dwarves*  
**Alfheim:** *see below, under Elves*  
**Northern Reaches:** +2 Loyal,  
-1 Forgiving, +1 Courageous,  
-1 Cautious

#### Character Class Modifiers

**Fighters:** +3 Courageous, -3 Cautious  
**Clerics:** +3 Reverent, +2 Dogmatic,  
+1 Loyal  
**Magic Users:** -2 Courageous,  
+2 Cautious, -2 Trusting  
**Thieves:** -2 Honest, +2 Cautious,  
-2 Trusting  
**Dwarves:** -2 Trusting, +2 Dogmatic,  
-2 Generous  
**Elves:** +2 Honest, -2 Modest, +2 Cautious  
**Halflings:** +2 Peaceful, -2 Cautious,  
+2 Energetic

#### Immortal Served Modifiers

**Odin:** -1 Peaceful, +1 Courageous  
**Thor:** -6 Peaceful, +3 Courageous,  
-3 Cautious  
**Frey/Freyja:** +1 Loyal, +2 Peaceful  
**Loki:** -3 Honest, -3 Dogmatic

gers offering gifts (Cautious 15). Onund's player isn't sure what Onund would do in such a tricky situation, so decides to check both traits to see whether Onund accepts the crone's offer.

The player rolls the dice. Onund passes his Trusting check with a 5, and passes his Cautious check with an 11. Since both checks are successful, the higher score has the greater influence. Onund peers thoughtfully into the cauldron, and cautiously but politely declines her offer.

### CHOOSING PC TRAIT SCORES

For each personality trait, choose a number from 1-20 to represent how strongly the character is influenced by that personality trait.

For example, if your character is a fighter, he should probably be fairly Courageous. Choosing a Courage trait score of at least 10, or as high as 20, might be appropriate. A magic user, on the other hand, might think it no shame to be much more Cautious than Courageous, and so might have a Cautious trait score of 10 to 20, and a Courage score of no higher than 10.

Trait scores of 15 or more indicate very strong personality traits. Conversely, trait scores of 5 or less are equally strong expressions of the opposite trait. Note that the characteristics are always referred to in their positive form—Peaceful, Honest, or Forgiving—even if the character has a low rating in that quality, implying the opposite behaviors are a more picturesque assessment of the person—Violent, Deceitful, or Vengeful.

Characters with very high or very low trait scores will develop a reputation for these strong traits. As they become more famous and successful, anyone who recognizes them is likely to know them in terms of those very high and low trait scores. (See "Reputation" on page 12 for more details.)

If a player chooses, he or she may use the NPC Random Traits Score system (below) to determine a character's personality trait scores. In this case, the player has less control over the scores the character will have. However, used with caution, experienced players will find it a

rewarding challenge to play a character with unusual traits that they would never have chosen themselves.

### NPC RANDOM TRAIT SCORES

DMs may follow the procedure below to establish a character's trait scores with the aid of dice and random chance. The DM is not obligated to use this table to determine NPC trait scores; he or she may always assign or alter NPC initial trait scores as needed for scenarios. However, once an NPC's traits have been established, major changes are not appropriate without a very good explanation and justification.

Examine the modifiers noted on the Personality Trait Chart to understand how alignment, nationality, character class, and dedication to an Immortal may affect a character's personality. Read the Trait Descriptions below before continuing, so that you understand what kinds of behavior each trait represents.

1. Choose alignment. Characters of each alignment establish their trait scores differently, as indicated on the chart to the left. Alignment must be decided before continuing.

2. For each trait, roll dice as directed to determine the trait score for each alignment. Roll for each trait score separately. Lawfuls roll 1d6 and add 12. Neutrals roll 1d6 and add 6. Chaotics roll 2d6. Record the scores in pencil; you'll continue to alter the scores in the steps below.

Note that Lawfuls generally have high trait scores. Neutrals generally have lower trait scores. Chaotics' trait scores vary the most, and are generally lower than either Lawfuls or Neutrals.

3. Assign National, Character Class, and Immortal Served Modifiers. Certain nations, cultures, and Immortals favor some traits over others, and each character class has its own preferred character traits. Alter the trait scores as directed on the table.

4. Distribute optional points to suit your conception of the character's personality (optional, for PCs developed using the random trait score system). You may add up to six points total to any one trait. You can add fewer than six points' worth,

## CREATING NORTHMAN PLAYER CHARACTERS

if you like, or make no changes at all.

### Trait Descriptions

The traits described here are organized in the same order the Personality Traits chart is organized. The characteristic and its opposite are treated together.

#### **Cautious (Rash)**

Cautious characters like to consider and discuss before they act. They are reluctant to act impulsively, even when haste is necessary. They're happier when back-up plans and escape routes have been plotted out in detail.

Rash characters do the first thing that comes to mind. They might think that acting quickly gives some advantage, or that they are clever at improvising a plan once they have gained the initiative. The other explanation is that they may simply be unable to control their impulses.

#### **Modest (Proud)**

Modest characters are humble, tending to understate their own accomplishments and abilities. They are not easily offended when others criticize or mock them, and they easily ignore jokes or taunts.

Proud characters have a poor sense of humor when it comes to themselves, and their principles and beliefs. They are quick to avenge an insult, real or imagined, and feel compelled to answer challenges, even when they are at a considerable disadvantage.

#### **Peaceful (Violent)**

Peaceful characters prefer an ordinary normal life to a life of conflict. When possible, they try to resolve disagreements by negotiation and, when threatened by violent enemies, they try to eliminate the threat with the least danger of injury to themselves and others. On the other hand, peaceful personalities need not avoid all violence categorically. They understand that it can be a necessary defense against a violent opponent. A peaceful character will simply try the other choices first.

Violent characters enjoy fighting for

the sake of fighting. They think negotiation is undignified and cowardly, and scorn those who shrink from violence. In hostile dungeons or wildernesses, or in warfare, violent people may make good heroes. In civilized regions, such people are a definite danger to society.

#### **Generous (Greedy)**

Generous characters give freely of their time and wealth to friends, family, and clansmen, and are prudently generous even to strangers. They carefully honor the rules of hospitality, extending protection to guests or victims of misfortune or evil.

Greedy characters don't like to share their time or wealth with others, and are always eager to add to their possessions. Such people are scorned by the Northmen but, at the same time, Northmen respect a wealthy man, and the only way to become wealthy is to be careful with the belongings you do have.

#### **Courageous (Fearful)**

Courageous characters don't hesitate to confront danger—even when it might be smarter to go around it or to try to confuse it. Sometimes it is difficult to distinguish between courage and stupidity.

Fearful characters prefer to get out of a dangerous situation, occasionally leaving at a dead run. Fearful behavior can be a matter of careful, sensible evaluation of the odds, and sometimes it is simply a failure of nerve.

#### **Reverent (Godless)**

Reverent characters honor and fear the Immortals and their servants on the Prime Plane. They faithfully observe the rituals and strictures of the Immortal's cult, and give great weight to the counsel of priests and holy men. Their faith makes them strong, and occasionally hard-headed or foolish in following the principles of their cult.

Godless characters may refuse to honor the Immortals on principle, or they may simply be careless or frivolous in their religious observances. Even a reverent character might sometimes doubt the

wisdom of an Immortal and his servants, or may compromise his principles in a difficult or ambiguous situation.

#### **Forgiving (Vengeful)**

Forgiving characters understand that no one is perfect, and that people sometimes act carelessly or thoughtlessly without necessarily being evil. Forgiving characters also realize that other people may not share their enlightenment, and make allowances for the ignorant and uneducated.

Vengeful characters know that the only way to eradicate evil behavior is to punish it ruthlessly. They treat an offender harshly, believing that he'll hesitate before he offends again. Even normally forgiving persons may sometimes be vengeful, particularly when an important loyalty or principle is involved—or when the person is in a particularly bad mood.

#### **Energetic (Lazy)**

Energetic characters are always eager to be doing something, even if it is the wrong thing. They consider laziness a great evil, and consider it a virtue to work for the sake of working, if there is no better reason.

Lazy characters can't see what all the fuss is about. Haste makes waste, they say. They often conceive very elaborate excuses for avoiding tasks that they are just too lazy to do. Even energetic people get tired and fed up sometimes, refusing to budge—because they are usually so energetic, they feel entitled to relax now and then.

#### **Honest (Deceitful)**

Honest characters tend to speak the truth, even when it might have been better to keep quiet. They may be painfully frank, and may thoughtlessly reveal information they should have kept secret. On the other hand, you can generally trust what they say.

Deceitful characters seem to actually enjoy telling untruths. Sometimes such characters misrepresent the truth to take advantage of others. Other characters may speak untruths or wild exaggerations just to be entertaining, or to make themselves seem more important. A character who fails

## CREATING NORTHMAN PLAYER CHARACTERS

to be honest doesn't necessarily lie. More often, he simply fails to tell the whole truth, or he refuses to say anything.

### **Trusting (Suspicious)**

Trusting characters see themselves as trustworthy, and expect others to be trustworthy also. They tend to accept others at their word, and can be duped by dishonest or deceitful persons.

Suspicious characters may be suspicious because they themselves are sneaky, or they may have learned their suspicious nature after painful experiences with deception. Occasionally even very trusting persons hesitate to trust others, perhaps on the basis of a vague intuition, or when remembering the warnings of other acquaintances.

### **Loyal (Unreliable)**

Loyal characters honor friendships, oaths, and personal, family, and social obligations. Unreliable characters may be consistently self-centered and careless of others, or may seek advantage by betrayal. When normally loyal people act unreliably, it may be an isolated incident of forgetfulness, carelessness, or inconsiderateness.

### **Dogmatic (Open-minded)**

Dogmatic characters tend to follow the letter of the law, regardless of extenuating circumstances. Law and tradition are sacred, and disagreeing with their principles is evil. They often emphasize justice over mercy, and have a reputation for hardheadedness and moral arrogance.

At their best, open-minded characters can consider both sides of a problem, and are not bound by the blinders of habit and tradition. At their worst, they are completely arbitrary and unpredictable, and honor no principles but their own whims.

**DM Note:** For all their virtues, Lawfuls can hardly be credited with being open-minded. In fact, their narrow-mindedness often keeps them from appreciating other points of view, and makes them unsympathetic where they could be more understanding and compassionate. On the other hand, being open-minded isn't always a

virtue. Being open-minded about torture or mass slaughter is hardly praiseworthy, for example.

## Reputation

Adventurers in the Northern Reaches are like sports personalities in the modern twentieth century world. The more experienced a character becomes, the more people will recognize him or her, and the more they know about that character's history and personal life.

A PC or NPC adventurer may be recognized by another character. Someone who recognizes a character will know that character's Reputation—those character traits that are exceptionally high or low.

### **RECOGNIZING AN ADVENTURER**

Skalds have a chance of recognizing a PC or NPC adventurer equal to 10% multiplied by the character's level. Thus, a skald has a 20% chance of recognizing a second level character, and a 100% chance of recognizing any character at tenth level or higher.

Normal men and adventurers without the Skald skill have only a 5% chance per level of recognizing another adventurer. Consider Attack Ranks as equivalent to levels for purposes of recognizing a non-human adventurer.

### **KNOWING AN ADVENTURER'S REPUTATION**

When a character is recognized, his most distinctive traits are known. Any trait with a score of 16 or higher, and any trait with a score of 5 or lower, is identified by the one who recognizes the character as either "high" or "low." The exact trait score is not known. These high or low traits are known as a character's "reputation."

**Example:** Bjarni Droop-Lid, a 4th level fighter, strolls into the Crushed Thrush Tavern and looks around. He sees a slightly overweight, balding dwarf slumped over a table in the corner, snoring fitfully.

**Bjarni's Player:** "Say, do I know that guy?"

**DM:** "It's pretty dark, and his head is cra-

dled in his arms. Want to go over for a closer look?"

**Bjarni's Player:** "Sure. I go poke him the ribs until he looks up at me."

**DM:** "Uh, give me a second." (Bjarni's no skald, for sure, but the snoring figure is Dwalinn, a dwarf with an E Attack Rank. Starting at Dwalinn's 12 levels at 5% each (60%), plus an additional 25% for Attack Ranks A-E, Bjarni has an 85% chance to recognize Dwalinn.) "Okay, roll percentiles."

**Bjarni's Player:** (Rolls a 43.) "Do I recognize him?"

**DM:** "Sure enough. That's Dwalinn the Dwarf, a noted adventurer."

**Bjarni's Player:** "Oh yeah! What's his reputation?"

**DM:** (Looking at Dwalinn's traits.) Well, he likes to fight (Peaceful 4), he's pretty impulsive (Cautious 5), and he doesn't show much respect to the Immortals (Reverent 3). (Adding a little flourish.) "And you've heard he doesn't like to be disturbed while he's sleeping."

**Bjarni's Player:** "Oh. Say, did I leave the door open on the way in?"

## Determine Nationality, Clan and Domain

Dominions are usually known by the name of the ruling clan; thus, the Olvasford clan's dominion is known as "Olvasford." The Great Hall of the ruling clanhead is located in the town or village indicated on the clan charts printed on the following pages. (Olvasford clan's Great Hall is in the town of Wilmik.) There may be one or more domains under a single clan's dominion. If a character's clan controls more than one domain, then one of them must be chosen as the home domain.

### **Clan Obligations**

1. *Clansmen must obtain permission to travel or take employment outside the clan's dominion. PCs must visit the clan's Great Hall and apply in person for permission from the clanhead or subordinate clan chief. Such permission is usually automatic for PC adventurers. However, a DM may decide to hold characters with-*



## CREATING NORTHMAN PLAYER CHARACTERS

in the dominion for campaign reasons.

2. *Clansmen must answer a call to arms from their clanhead.* An adventurer who hears his clan is in trouble is expected to drop everything and come to its aid, even if he must travel long distances and for-  
sake valuable opportunities.

3. *Obey the clanhead.* Normally, when a character is away from his home domain, he won't have to deal with such orders. However, an entire adventure might be based on a character's response to an unjust order.

4. *Protect the reputation of the clan.* Player characters are expected to bring glory to the clan, to make the clan proud. Characters are also expected to stand up for the clan. Failure of a Modest trait check may induce a character to fight to avenge insults to the clan's good name.

### Clan Benefits

1. *A clansman is always entitled to the hospitality of the clan from a fellow clansman,* including food, shelter, and weapons.

2. *A clansman may expect the aid and protection of other clansmen in honorable and worthy endeavors.* This doesn't mean a clansman is obligated to drop everything to help, regardless of his own interests—unless the player character has the authority

of a jarl. Defense of the clan as a whole, however, is a strong obligation.

3. *Clansmen are familiar with the land, the climate, and the peoples of his clan and home domain.* A clansman knows his home domain very well. He is familiar with local legends, and knows where to go for the most generous lodgings, best information, or strongest aid. For more difficult or obscure information, the DM may request an Intelligence check.

### Obtaining a Dominion ——— (D&D® COMPANION DM Rules)

A dominion may be obtained in two ways: by a successful challenge of a clanhead, or by colonization of an unoccupied dominion.

### Challenging a Clanhead

This is obtaining a dominion by conquest (see D&D® Companion DM Rules, page 4). Normally a dominion must be conquered by armies. The kings of Vestland and Ostland already control armies powerful enough to prevent a player character from raising a force that could threaten their security. Soderfjord, on the other hand, is poorly organized and unable to prevent the small internal wars that result

in dominions changing hands.

A player character may also challenge the clanhead of his own clan for rulership. The character must be of name level, and must defeat the current headman (or his champion) in single combat. A player who wants his character to challenge the head of that character's clan should inform his DM. The DM will then prepare an opponent and decide the conditions of the challenge; these are the rights of the challenged clanhead in disputes over clan leadership.

### Colonization

Areas designated as "wilderness" on the large map may be colonized with the permission of the nation's ruler or ruling body. A borderland or wilderness dominion may be obtained with a charter from the King of Vestland or from the Council of Soderfjord. There are no opportunities for colonization in Ostland but the DM may permit landseekers to start or expand colonies on the Isle of Dawn with the support of the King of Ostland.

Any territory not already settled in the Northern Reaches tends to be terrain less than suitable for human habitation, or already occupied by powerful, hostile non-human races.

## Ostland Clans and Dominions

Some clans hold more than one of the domains marked on the fold-out map. No Ostland domains are landlocked.

Clan Name	Head of Clan	Great Hall	Domains
Vestpont	Anlaf Geirmundson	Port Swenson	Vestpont
Sumarland	Gest the Hook	Lenvik	Sumarland
Ringmark	Herjolk Eirikson	Fjallasen	Ringmark
Hammersholm	Sigrid Halldorson	Marmaty	Hammersholm
Noslosford	Geirstein Thorgelson	Leirbotn	Noslosford
Vithesford	Ragnar Solmundson	Storm Bay	Vithesford, Thorholm
Varmgard	Askold Ubbison	Zeafort	Varmgard, Aland
Haltimark	Sigvaldi Thorirson	Ankarson	Haltimark
Havardholm	Bodvar Dogleg	Kroken	Havardholm
Suddmore	Gunnhild Svalasdottir	Suddpont	Suddmore
Romaland	Hygelac the Doubter	Shipton	Romaland, Steingard
Fallersholm	Karlsefni Garson	Kirkesdahl	Fallersholm
Zeamark	King Hord Dark-Eye	Zeaburg	Zeamark, Hedmark
Gotland	Mord the Greedy	Bergfors	Gotland
Osterlo	Starkad the Hunter	Saltshore	Osterlo
Sognesholm	Rollo the Cruel	Osknes	Sognesholm
Ostmanland	Thorir the Wealthy	Ostmanhaven	Ostmanland
Kalsloviki	Rognvald the Raven	Galten	Kalsloviki
Oland	Ottar the Swimmer	Abisko	Oland
Kunslo	Hakon Halfdenson	Sati	Kunslo

## Characters

### Vestland Clans and Dominions

Some clans hold more than one of the domains marked on the fold-out map. Domains marked with an asterisk (\*) are landlocked.

Clan Name	Head of Clan	Great Hall	Domains
Hostmore	Askold Steinson	Hostpork	Hostmore
Valgard	Aslak Illugison	Laisvall	Valgard
Grosfold	Erik Rhorvaldson	Halmstad	Grosfold
Marsfjord	Runolf the Dandy	Dremmen	Marsfjord
Sveamark	King Harald Gudmundson	Norrvik	Sveamark
Fosterhead	Alfgeir Vagnson	Valjok	Fosterhed
Ranviki	Gorm the Droll	Bergen	Ranviki
Falsterholm	Thrain Helgason	Namsen	Falsterholm
Fynmark	Rurik Sturlason	Sudorn	Fynmark
Namahed	Eyvind the Odd	Tromso	Namahed, Verfjord, Jamtfjord
Skanicost	Horsi Ulfson	Grebbestad	Skanicost
Norrland	Skapti the Skald	Dovefell	Norrland
Bornbank	Rotolf Kalfson	Vanger	Bornbank, Hrutmark
Brandholm	Erlund the Droll	Kyskmoen	Brandholm
Hennesdalir	Vandrad the Strong	Helaga	Vestfjord
Landersfjord	Arnulf Burison	Landersfjord	Landersfjord
Haverhold	Leif the Lean	Haverfjord	Haverhold
Uplands	Bersi Broadaxe	Hedal	Uplands*
Hallmark	Herigar Tree-Foot	Linghed	Hallmark*
Rhoona	Gudwulf the Golden	Rhoona	Rhoona

### Soderfjord Clans and Dominions

Some clans hold more than one of the domains marked on the fold-out map. Domains marked with an asterisk (\*) are landlocked. Clanhead marked † is war leader of the Soderfjord Jarldoms.

Clan Name	Head of Clan	Great Hall	Domains
Olvasford	Sokki Sturlson	Wilmik	Olvasford
Suddland	Ulf Kolson	Labbas	Suddland, Moderfeld*
Heddesfjord	Gudrid Thorsdottir	Harby	Heddesfjord, Hordamark
Soderfjord	Ragnar the Stout†	Soderfjord	Soderfjord
Vithesfeld	Thorkell Gydason	Lerum	Vithesfeld
Bergholm	Floki the Fat	Dorna	Bergholm
Vastergard	Harek Hard-Sailer	Rollag	Vastergard
Vandermark	Knute the White	Treungen	Vandermark, Rogaviki
Haltford	Halfden Greybeard	Morden	Haltford, Borkmark
Oberbeck	Vigfus Ketilson	Gargnas	Oberbeck
Ozurfold	Vandrad Horikson	Whiteheart	Ozurfold, Rurrland*
Hedden	Ceowulf War-Tooth	Backwater	Hedden, Gudholm*
Hadmark	Helgi Horse-Killer	Aurskog	Hadmark, Dealand*
Highland	Ketil Skull-Scatterer	Highhold	Highland*
Hillgard	Steinthor Pin-Leg	Maula	Hillgard*
Ranholm	Ottar Heathcock	Kassler	Ranholm*
Boddergard	Guthorm Brittle-Bone	Ranwood	Boddergard*, Hodderland*
Gretmarsh	Thorbjorn Rorikson	Sortfeld	Gretmarsh, Otterland*
Nordcastel	Rollo Harekson	Snowvale	Nordcastel*
Castellan	Solvi Hardhand	Castellan	Castellan*

## TRAINING BACKGROUND AND BEGINNING SKILLS

**BEGINNING SKILLS:** All beginning (first-level) Northman characters know four skills: two skills related to character class, and two background skills. These skills are determined with the Training Background Table found on the next page. Read the table for directions to determine your character's four initial skills.

**BONUS SKILLS:** A beginning character knows more skills if he is particularly intelligent, exactly as a character knows more languages if he is intelligent. If he has an Intelligence of 13-15, he knows one extra skill (for a total of five). If she has an Intelligence of 16-17, she knows two extra skills (for a total of six.) If he has an Intelligence of 18, he knows three extra skills (for a total of seven.) These skills are selected from the skills described on the next several pages.

Note that the optional Step Six in Northland character creation may affect Intelligence or other ability scores, and therefore change how many skills and which ones may be obtained. Some elements of Step Six depend on earlier steps, so just work in pencil and be prepared to make adjustments as necessary if you use that step.

**HOW SKILLS ARE USED:** Each skill is based on one of a character's ability scores (Strength, Intelligence, Wisdom, Constitution, Dexterity, or Charisma).

During a game session, the DM may decide that a character's skill may help him in a situation. Also, the player may ask the DM to consider whether his character's skill might be applicable, but it is the DM's decision.

If the DM decides use of the character's skill is appropriate to the situation, the player is asked to roll a twenty-sided die against the current ability score the skill is based on. If the roll is equal to or less than the ability score, the skill has been used successfully.

### GUIDELINES FOR SKILL USE

- In most circumstances, skills cannot be used against other player characters. Certain skills, particularly Charisma skills, can be used only against NPCs.

- A roll of 20 always fails. The higher the successful roll (so long as it is successful!), the more effectively the skill has been used. The more difficult the task, the more modest the benefits of a successful check.

- A roll of 1 is *not* an automatic success. When a very difficult task is attempted, the DM may assign penalties to the roll to reflect the increased difficulty of the task. If the task is *exceptionally* difficult, the DM may rule before the dice are rolled that, although the effort is remotely possible, it is incredibly unlikely. In such a case he or she may require the player to roll two consecutive 1's to succeed at a task. If the player can roll two consecutive 1's, a case can be made for divine inspiration!

- The DM may decide that use of a skill in easy tasks is automatic, or receives a bonus to the roll.

- The DM determines the amount of time required for a successful use of a skill. Building a small boat may take several days, while identifying a curious artifact may take only seconds.

- The DM determines the conditions concerning the successful use of a skill. He may rule that successful use of the Sailing Weather skill will give advance warning of a storm, or he may rule that it only permits the character to deal with the storm when it strikes, according to circumstances.

- The DM's ruling is final. If, as a player, you think a judgement was unreasonable, discuss it with the DM after the game, with the hope of avoiding misunderstandings in the future.

**IMPROVING SKILLS:** If you wish, a character's skill score may be raised above the ability score that the skill is based on. To improve a skill score, you must trade in one ordinary skill choice to increase a different skill score by one point.

Such an improved skill is indicated on

a character sheet by marking the number of additional points with a "plus" sign after the skill name (i.e., Jeweler +1, Nature Lore +2, etc.). Improving a skill increases the chance of a successful check against that skill. Other benefits conferred by that skill are not affected. These are permanent choices; you cannot shuffle skill scores after the character starts adventuring.

### NOTES ON THE TRAINING BACKGROUND TABLE CLASS-RELATED SKILLS

Young fighters learn to be very aggressive in combat. They also learn how to intimidate, which allows them to avoid bloodshed without being cowardly.

A Northman thief wants to avoid violence. He cultivates stealth and avoidance rather than combat skills.

Those destined to be Northman clerics are schooled by local priests in the cult principles and rituals.

In addition to basic spellcasting, magic users learn to read for research, and a general history of the Northern Reaches.

### BACKGROUND SKILLS

**Sailor, Farmer/Herder:** Hard physical labor and the associated skills.

**Craftsman:** This represents a basic apprenticeship in the chosen craft.

**Laborer, Servant/Thrall:** This represents physical and/or menial work. Even characters of high social class may have such a background due to clan obligations or family disgrace. Labor is not a respected vocation in the North.

**Merchant/Trader:** Usually working for an experienced merchant or trader for low wages. May include selling in village markets and traveling with caravans.

**Hunter:** All occupations where one must live off the land in wild regions.

**Priest of Odin:** Generally important clan counselors, valued for their shrewd thinking and diplomatic skills.

## Characters

### TRAINING BACKGROUND Table

Each Northlander character begins with a background occupation, two skills related to that occupation, and two skills related to character class. The class-related skills reflect a character's early personal tendencies and interests; the background skills reflect training received from various individuals, and experiences as the character grows up. To use this table, start at "A" and only apply those conditions that relate to your character.

- A. If the character is a FIGHTER, ELF, or DWARF:  
the two class-related skills are *Fighting Instinct* and *Intimidate*.
- B. If the character is a THIEF or HALFLING:  
the two class-related skills are *Surprise* and *Evade*.
- C. Background skills for FIGHTER, ELF, DWARF, THIEF, or HALFLING characters:  
Roll 2d4 to determine training background. If the character is from a seacoast or river clan, - 1 to roll. If from a landlocked clan, + 1 to roll. When background is determined, choose two skills from that background.
1. Sailor: *Boating, Navigation, Ship Building, Sailing Weather*
  2. Craftsman: *Carpentry, Metalsmithing, Bowmaking, Tanner, Potter, Tinker, Jeweler*
  - 3-4. Farmer/Herder: *Nature Lore, Stamina, Outdoorsman, Horsemanship*
  - 5-6. Servant/Thrall: *Domestic Crafts, Deceive*
  7. Laborer: *Muscle, Stamina*
  8. Merchant/Trader: *Know Market Value, Persuade, Deceive, Gain Trust, Horsemanship*
  9. Hunter: *Hunting, Nature Lore, Stamina, Outdoorsman, Horsemanship*
- D. If the character is a CLERIC:  
the two class-related skills are *Read Runes* and *Honor Immortal*.
- E. Background skills for a CLERIC:  
Choose Immortal served, and choose two skills honored by that Immortal. The DM may rule that player characters cannot be Loki clerics, since they are often rabid chaotics deeply distrusted by almost all Northlanders.
1. Priest of Odin (Lawful or Neutral): *Detect Deception, Persuade, Skald*
  2. Priest of Thor (Lawful or Neutral): *Fighting Instinct, Intimidate, Skald*
  3. Priest of Frey/Freyja (Lawful or Neutral): *Nature Lore, Gain Trust, Skald*
  4. Priest of Loki (Chaotic only): *Deceive, Detect Deception, Skald*
- F. If the character is a MAGIC USER:  
the two class-related skills are *Read/Write Language* and *Ancient History*.
- G. Background skills for a MAGIC USER:  
Roll 1d6 to determine training background, and choose two skills.
- 1-5. Private Apprentice: *Read Runes, Skald*
  6. Magic College Graduate: *Planar Geography, Non-Human Cultures, Magical Engineering, Alchemy, Alternate Magics, Clerical Magics*

**Priest of Thor:** Generally these are warrior chaplains, sharing the living quarters and lifestyle of warriors.

**Priests of Frey/Freyja:** Considered the guardians and counselors of the common man, and protectors of the poor and weak, they live humble lifestyles.

**Priests of Loki:** Loki worship is rarely public. Most priests adopt the disguise of a vagabond or mercenary.

**Apprenticeship/Magic College Graduate:** Most magic users learn the basics through an apprenticeship to an experienced spellcaster. A select few are admitted to the College of Norrvik. Poorer candidates receive scholarships or earn their keep with part-time jobs.

**Learning More Skills:** As time goes by, your character may gain more skills or improve existing skills.

All characters get a new skill choice every four experience levels. Thus they get their first skills at Level 1, then a new skill at Level 5, another at Level 9, another at Level 13, and so on.

Each new skill choice may be used to acquire a new skill or to improve an old skill in the manner described above.

**Maximum Skills Known**

by Character Level and Attack Rank

- Level 1: 7 skills.
- Level 5: 8 skills.
- Level 9: 9 skills.
- Level 13/Rank C: 10 skills.
- Level 17/Rank E: 11 skills.
- Level 21/Rank G: 12 skills.
- Level 25/Rank I: 13 skills.
- Level 29/Rank K: 14 skills.
- Level 33/Rank M: 15 skills.

**Skills and the Character Sheet:**

Record your skills on your character sheet in this fashion: Find a blank spot on the sheet. Write "Number of Skill Choices: \_\_\_\_\_", leaving room beneath that. Record on the line the number of starting skill choices your character received.

Below this, write down your character's skills. Record the name of the skill, the abbreviation of the ability the skill is based on, any permanent modifier you have obtained for the skill by devoting extra skill choices to it, and the current skill roll you have with the skill.

**Example:** Erik the Prune, a sour-faced Vestlander cleric (*S12, I14, W16, C13, D9, Ch7*) is beginning his adventuring career. His Intelligence of 14 gets one extra skill choice. After he determines his skills on the Training Background Table, and selects his bonus skill, his sheet looks like this:

- Number of Skill Choices: 5
- Read Runes (I): 14
- Honor Odin (W): 16
- Detect Deception (W): 16
- Skald (I): 14
- Non-Human Cultures (I): 14

**Skill Descriptions**

Below are the skills particularly appropriate or useful in a Northern Reaches campaign, listed according to the ability score they are based on. This is not a complete list of all possible skills. You may suggest other skills to your DM, and he or she may have other skills to choose from.

Do not overlook the possibility of essentially useless but entertaining skills. Skills can be useful to characters for in-session problem-solving, but a skill doesn't have to be useful to be desirable—it can just be fun. Don't hesitate to ask your DM for a skill that might not be very useful, but which perfectly fits the personality you've imagined for your character.

**Strength Skills**

**Intimidate:** The ability to bully others into doing what you want them to do. Successful use means that NPCs who generally don't like something like fighting (most normal people) are intimidated into doing what they can.

This works best against civilians and non-fighter types. NPC adventurers and other fighter-type NPCs (guards, thugs, bouncers, etc.) may ignore a successful use of this skill if they succeed in either a

Modest or a Courageous check.

**Muscle:** Knowledge and experience with heavy lifting and hard labor. The character knows how to direct groups of laborers to make their efforts most effective. He understands the use of simple machinery like wedges, pulleys, and levers. Character receives a +2 bonus on Strength checks for difficult tasks like bending bars or smashing through doors and walls.

**Intelligence Skills**

**Boating:** The ability to handle small boats or perform as a crewman on a larger ship. Also includes fishing skills. Most simple tasks are performed automatically by characters with this skill; check against this skill only in critical or emergency situations.

**Helmsman/Captain:** The ability to handle a larger ship and direct a competent crew. This doesn't include handling challenges to a captain's authority—a mutiny, for example—which would be decided by a Charisma check or use of some other appropriate skill (Intimidate, Persuade, Deceive, etc.).

**Navigation:** The ability to guide a boat or ship to an unfamiliar destination or in unfavorable circumstances (fog, storms, night, etc.). Use of this skill presumes possession of a sextant or sky reader, maps, and other navigational aids. If any of these are not available, a penalty of -4 to -8 may be imposed.

**Ship Building:** The ability to build boats and ships, and to keep them in good repair. Use of this skill presumes adequate time and access to appropriate tools and materials. Otherwise, penalties may be assessed, or DMs may rule that the task is impossible.

**Sailing Weather:** The ability to anticipate sea and weather conditions—to take advantage of them, or to avoid their dangers. A successful use might increase a vessel's speed, for example, or warn of an impending storm.

**Read Runes:** The ability to read the sacred runes of the Northern Reaches. Successful use permits a literal reading of the message. Understanding the sacred or profound meanings of the runes requires separate use of the interpret runes spell.

## Characters

Activating a Rune of Power requires use of the *bless* spell (p. 27).

**Nature Lore:** Knowledge of common plant and animal life of a familiar locality, both domestic and wild. This includes knowing such things as edible and poisonous plants, healing herbs, or signs of unnatural danger like unusually quiet forest, absence of normal plant life, atypical animal behavior, etc.

Use of this skill in the character's home dominion receives a +2 bonus. Use of this skill in an unfamiliar but similar setting is at a -2 to -4 penalty. For example, a hunter from the foothills of the Hardanger Range might be at a -2 penalty on the moors of northern Vestland, or a -4 penalty in the mountains of Rockhome. A native Northlander is presumed to have at least some hearsay knowledge of plants and animals throughout the Northern Reaches.

**Know Terrain:** The knowledge of the land, water, and weather of a region. This includes knowing the safest or fastest travel routes, pathfinding, local waterways, and dangerous weather conditions.

Use of this skill in the character's home dominion receives a +2 bonus. Use of this skill in an unfamiliar but similar setting is at a -2 to -4 penalty. Northland natives are presumed to have at least some hearsay knowledge of land, water, and weather throughout the Northern Reaches.

**Outdoorsman:** Experience with and knowledge of wilderness travel, camping, and survival techniques.

**Know Market Value:** A character with the skill automatically knows the market value of common goods, including standard D&D® game equipment items. Successful checks allow one to estimate the approximate value of special goods like magical items and treasures.

**Skald:** Knowledge of traditional verses concerning Northland traditions, legends, and heroic figures, and the ability to present the tales to an audience. The higher the successful roll (so long as it is successful), the finer the presentation. To create original verses glorifying the deeds of modern heroes, checks are made at a -4 penalty.

**Read/Write Language:** Fluency in a language common in the Known World. The language chosen may be from

another D&D® game nation, or may be selected from the List of Common Languages, *D&D Basic DM Rules*, page 18.

**Ancient History:** Detailed knowledge of Northern Reaches history and prehistory. General knowledge of the history of other D&D game nations and non-human races.

**Planar Geography:** General knowledge of the Prime, Inner, Outer, Astral, and Ethereal Planes as described in the *D&D Companion Player Manual*. Includes knowledge of techniques of travel among planes and common inhabitants of better-known planes.

**Non-Human Cultures:** General knowledge of non-human races of the Northern Reaches. Includes incomplete knowledge of non-human customs, methods of warfare, skills with magic, and a very basic vocabulary (about 20-30 common words).

**Magical Engineering:** Ability to recognize basic principles of some unfamiliar magical devices. Does *not* include practical training in design or fabrication of magical artifacts. Does include recognition of most common magical items.

**Alchemy:** The ability to recognize and identify common alchemical substances and potions.

**Alternate Magics:** Basic familiarity with those magics which are not related to standard spellcasting. Includes knowing magical abilities of well-known magical Prime Plane and extra-planar monsters, and of Immortal beings.

**Clerical Magics:** Ability to recognize and identify magical effects associated with clerical spells and other magical abilities. At the DM's option, may permit occasional operation of clerical items by magic users, but this is universally acknowledged as extremely dangerous—it can result in destruction of the object and the user if the skill check fails.

### Wisdom Skills

**Detect Deception:** The ability to recognize deceptive tricks or behaviors in an NPC. This does not reveal the truth or falsity of statements nor the motivations of the speaker, nor does it reveal the exact nature of the deception. Unlike the

*detect lies* spell, this skill only warns the character to distrust the NPC who is trying to deceive him. The character gets no clues about which statements are true or untrue. Successful use of this skill just indicates that the speaker is intentionally trying to deceive the character.

**Honor (Specific Immortal):** The ability to properly honor an Immortal to gain his favor and aid. This includes knowing the code of behavior and the rituals pleasing to the Immortal in question.

This skill enables clerics to obtain use of clerical spells. Use of this skill by a cleric is automatically successful in routine situations. If the cleric has performed actions displeasing to his Immortal, he may be required to make a skill check. Failure may mean that the cleric does not receive one or more of his spells, or that he suffers some other penalty, such as a temporary curse.

Use of this skill by non-clerics normally permits only knowledge of appropriate codes of behavior and rituals. However, any character, cleric or non-cleric, may use this skill to request "divine intervention." The character must permanently sacrifice 1d10 hit points to request an immediate one-time use of any clerical spell, regardless of level. If the skill check is successful, the hit points are lost, even if the Immortal denies the character's request. A character with fewer than 10 hit points risks killing himself this way.

### Constitution Skills

**Stamina:** The ability to continue arduous physical activity for long periods, and to endure physical hardship. Character can run twice as long—40 rounds, 10 minutes—without becoming exhausted (see "Movement", *D&D Basic Player Manual*, p. 56). He moves as though encumbered at one class lower than his actual encumbrance (see Encumbered Movement Rates Table, *D&D Basic Player Manual*, p. 30), and receives a +2 bonus on any Constitution-based checks concerning resistance to effects of adverse weather or resistance to fatigue from extended periods of exertion.

**Dexterity Skills**

**Craftsman (Skill):** The ability to make and repair items associated with your craft, and the ability to evaluate the worth of such items. Craftsman skills include Carpentry, Metalsmithing, Bowmaking, Tanner, Potter, Tinker, Jeweler, and so forth.

DMs may choose to designate Craftsman skills as based on Intelligence rather than Dexterity, especially as the craftsmanship approaches the level of artistry. Here the skills have been included among the Dexterity-based skills because manual dexterity, patience, and practice are important in learning the basics of any craft. DMs may decide to use both designations in the same campaign, where an Intelligence-based crafter makes the lovelier products and a Dexterity-based crafter makes solid, serviceable goods.

**Domestic Crafts:** Knowledge of basic homecrafts providing shelter, food, and garments for a household. Includes cooking, spinning, weaving, sewing, shoemaking, housekeeping, etc.

**Fighting Instinct:** The reaction of impulsively attacking first in order to gain the advantage in combat. Successful use gives a +1 to Initiative in the first round of a combat.

**Surprise:** The ability to get the jump on an unsuspecting victim. May be used to attack (e.g., to jump someone from behind) or to avoid a conflict (e.g., to duck out of the hands of the man who caught you picking his pocket). Successful use gives a +1 to Surprise.

**Evade:** The ability to elude a pursuer. This skill comes through experience in running away from dangers. Successful use permits (where appropriate) a movement bonus of +10 feet per round for 10 rounds, giving the evader a chance to hide or throw the pursuer off his trail. If the situation is one of hiding, dodging, or outguessing a pursuer, a successful check allows the character to find some way to be overlooked.

**Hunting:** The ability to locate, stalk, and hunt large and small game with the bow. Successful use gives a +1 to hit with a bow in an outdoor setting. It is essentially useless inside a building, cave, or

dungeon.

This skill focuses more on the "hunting" than the "bow" and does not affect combat uses of other missile weapons.

**Horsemanship:** Knowledge of basic care and feeding of horses, and the ability to control a horse under difficult circumstances. A character can recognize a nag, but buying a suitable mount for a reasonable price requires a minimal skill check, as will attempting to perform various activities from the saddle. For example, most folk can stay in a saddle while a horse is walking, but staying there during a gallop or a combat is a whole different story. To use a weapon, spell, or skill while on horseback, a character must succeed in a horsemanship check, with penalties as the difficulty increases.

**Charisma Skills**

**Persuade:** The ability to prove your honesty and sincerity to NPC listeners. This skill cannot be used to deceive a listener; the speaker must believe in the truth of what he says. Successful use of this skill means the listener believes what the speaker tells him. It does not imply that the listener will agree to actions that are proposed by the speaker.

If the NPC listener is hostile, or has reason to distrust the speaker, the DM may assess penalties of -1 to -8 to the check. Alternatively, the DM may ask for opposed Charisma checks, or may require checks between the Persuade skill and the NPC's Trusting trait.

**Deceive:** The ability to persuade a listener of the truth and sincerity of what is said, despite the fact that the speaker is being untruthful, insincere, or both. Successful use of this skill causes an NPC to believe an untrue statement or to accept a misleading statement as honest and sincere.

The speaker need not actually lie to intend to deceive his listener. For example, the statement "We come in peace" may be literally true, in the sense that the speaker hasn't killed anyone yet. It may be misleading in the sense that the speaker is cheerfully willing to butcher anyone in order to reach his goal.

**Leadership:** The ability to appeal to an

audience to perform specific actions. A successful use of this skill permits the character to make an appeal to a given personality trait (Courageous, Loyal, Energetic, etc.) of an NPC listener—success means the player can get the listener's attention, not that he has persuaded him.

To actually encourage the desired action, the player decides with the DM which trait he will appeal to, according to the circumstances. For example, if the character is trying to get the listener to attack a dragon, he may appeal to a suspected high Courageous trait, or a low Generous trait (presuming a treasure is at stake). The player then makes a brief speech for his character, appealing to that trait. Then the DM rolls a trait check for the NPC. If the player's speech is really good, the DM should award bonuses to the check. If the check is successful, the NPC acts as the character requests. If the check is a failure, the NPC does not follow the character's request.

If the NPC listener is hostile, or has reason to distrust the speaker, the DM may assess penalties of -1 to -8 to the check. Alternatively, the DM may require opposed Charisma checks, or opposed checks between the Leadership skill and the NPC's Trusting or Loyalty trait, if appropriate.

**Gain Trust:** The ability to gain the trust of an NPC through a combination of courtesy, respect for traditions, knowledge of human nature, and honorable behavior. Successful use of this skill causes an NPC to accept the character as a trustworthy person until given solid evidence to the contrary.

In routine situations, a successful use of this skill is sufficient. This covers situations like an overnight visit to a roadside inn, seeking food and shelter at a farmstead, etc.

In dangerous or threatening circumstances, or if the NPC listener is hostile or already has reason to distrust the speaker, the DM may assess penalties to the check. The DM must examine the situation, and may require opposed Charisma checks between the PC and the NPC, or require opposed checks between the Gain Trust skill and the NPC's Trusting trait or any other trait appropriate.

# Characters

## Family Status

A young Northlander's reputation rests firmly upon the reputation of his or her immediate family. Until the Northerner proves himself later by his adult actions, he is judged by the reputation of his family. Outside his home locality, his family's reputation may be unknown.

Roll 1d100 to determine status. Write down the Charisma modifier next to the Charisma ability score on the character sheet, in parentheses. The DM will determine whether one's family's reputation is known outside one's home domain.

Roll	Status	Charisma Modifier
01-05	Honored	+2 Charisma
06-20	Respected	+1 Charisma
21-70	Unremarkable	No Effect
71-85	Doubtful Reputation	-1 Charisma
86-95	Scorned	-2 Charisma
96-00	Outlaw	-1d4 Charisma

## Heyday Gifts

In the Northern Reaches, one receives gifts from family, friends, and clansmen when one comes of age at sixteen. The sixteenth birthday is called one's "Heyday." Roll 1d100 to determine one's social status and Heyday inheritance.

Heyday gifts are intended to help the recipient begin a productive adult life. The gifts are generally either in coin or in the form of some useful object the recipient will need in his or her chosen occupation. Heyday gifts are in addition to any coin that the player character received in the Basic Character Creation procedure.

Roll	Social Class	Inheritance
01	Rich Noble	60 + 3d20 gp
02-04	Typical Noble	40 + 1d20 gp
05-10	Poor Noble	20 + 1d10 gp
11-15	Rich Freeman	40 + 1d20 gp
16-70	Typical Freeman	20 + 1d10 gp
71-85	Poor Freeman	1d10 gp
86-00	Servant/Thrall/Vagabond	1d10 sp

## Important Past Experiences

The optional tables on the next two pages indicate significant events that happen to your Northern Reaches character before he gives up the relatively safe but unrewarding occupation of "Normal Man" for the exciting life of a D&D® game adventurer.

These tables are only to be used in character creation! Once a character has begun earning experience points in an adventuring life, he or she may not use these tables.

Do not run a character through the tables more than once, although if you use any one table, you must use all. Some tables may yield benefits, others may yield misfortunes. You cannot gain if you are not willing to risk losing.

Use of these tables is subject to your DM's approval. He or she may prefer that you play standard characters as created with the D&D Basic Set Rules, or that you play Northern Reaches PCs without any additional changes.

Before you decide to use the tables, look them over carefully. Although the experiences may improve a character, some may injure or weaken a character. Life is not always kind. There is an element of risk in using these tables, which is one reason they are optional.

## Important Past Experiences Procedure

1. Roll first on the "Afflictions and Accidents Table," page 21. (Bad news first.) Change any abilities as directed.

2. Then roll on the "Significant Experiences Table," "Character Building Table," and "Combat Experience Table"

on page 22. Read the notes carefully and follow any instructions that apply to your character. Record any changes to abilities, personality traits, skills, or wealth.

When you are done, you might have a list of notations like this example:

Age 17: Good health.  
Generous teacher, +1 Con, gain +1 to  
Stamina skill  
Saw action in a small raid,  
+1 Courage  
Resolved to Change, work harder on weapons practice, +1 Energetic.

3. The last step is to figure out a story that fits these details. Add what you learned about the Northern Reaches in this Player Book to fill in the background. Create a brief biography for the character's year of pre-adventuring experience, and keep these notes on the back of your character sheet or on a separate piece of paper.

For the character given as an example, above, you might concoct a story like this:

*At 17, Rolf went to live with his uncle in Namahed to work on his sheep farm. The hard work and outdoor life toughened him, and cured him of sleeping late. Ostland pirates attacked a neighbor's stead that summer, and Rolf and his uncle helped drive the raiders off. Rolf didn't get in on much of the fighting, but he'll be better prepared if the raiders come again next year. He considered joining an expedition advertised in Tromso, but figured he wasn't ready for the adventuring life until he'd spent more time practicing his fighting technique.*





### Afflictions and Accidents Table

Roll 1d100. Subtractions will never drop an ability score below 7.

1	<b>Brown Plague:</b> Roll 1d6 and subtract that score from Constitution.
2	<b>Brain Rot:</b> -1 to all ability scores; no Annual Training, Character Building, or Combat Experience.
3	<b>Fading of Youthful Enthusiasm:</b> -1 Constitution, -1 Strength
4-8	<b>Minor Accidental Injury:</b> Roll 1d10 and see below: 1-2: Minor Injury to Hands, Arms, Feet, or Legs: -1 Dexterity 3: Head Injury: -1 Intelligence 4: Injury Affecting Breathing or Digestion: -1 Constitution 5: Disfiguring Scars: -2 Charisma 6: Bad Fall/Riding Accident/Wild Party: -1 Strength, -1 Dexterity 7-10: No permanent disability
9	<b>Gut Worms:</b> 10% chance of -1 Constitution
10	<b>Arthritis/Back Injury/Hernia:</b> -1 Dexterity
11-90	<b>Good Fortunes and Perfect Health:</b> No ability losses
91-93	<b>Dysentery:</b> 25% chance of -1 Constitution
94-96	<b>Sheep Pox:</b> -1 Charisma; 25% chance of -1 Constitution and -1 Strength
97	<b>Out of Shape:</b> -1 Dexterity, -1 Strength
98	<b>Poor Mental Health:</b> -1 Intelligence, -3 Wisdom
99	<b>Carrot Fever:</b> -1 to all ability scores; no Annual Training, Character Building, or Combat Experience
00	<b>Very Serious Accident:</b> Roll 1d6 and subtract that score from Dexterity

#### Afflictions and Accidents Table Notes

##### Brown Plague

Onset of the illness is so rapid that the victim is often desperately ill before treatment can be obtained. Only good fortune can prevent a serious reduction of one's overall health.

##### Brain Rot

A mysterious disease which exhibits no symptoms until the victim keels over without warning. Affects the brain and nervous system. Victim is bedridden for 1d4 months, and never fully recovers.

##### Fading of Youthful Enthusiasm

Individual prefers loafing around the tavern over studying or weapons practice. A common affliction, treatable by imposed exercise or desperate peril.

##### Minor Accidental Injury

This might be getting kicked by a horse,

stabbed in a tavern brawl, caught with the landlord's daughter, or any number of possible situations. Accidents will happen; fortunately, many injuries are not permanently disabling.

##### Gut Worms

Serious digestive disorder. Parasitic infestations of larger creatures cannot be cured by a *cure disease*, *remove curse*, or other magical spells. Parasites must be poisoned, and victim cannot be treated with *neutralize poison* until the parasites are dead.

##### Arthritis/Back Injury/Hernia

Unfortunately, these disabilities and others like them are permanently debilitating.

##### Dysentery

An unpleasant but generally minor ailment. Some victims develop permanent digestive problems in serious cases.

##### Sheep Pox

A common, highly contagious affliction. Once infected and recovered, victim is immune from further infection.

##### Out of Shape

Only exercise and dedication can maintain one's youthful trim and vigor. The longer you go without taking care of your body, the harder it is to change your lazy ways.

##### Poor Mental Health

This can come about by being scared silly, getting locked in a dungeon, joining a weird cult, or by several other imaginable situations.

##### Carrot Fever

A malaria-like disease transmitted by carrot parasites. (For notes on curing parasitic illnesses, see Gut Worms above.)

## Characters

### Important Past Experiences Table Notes

This table indicates an important experience affecting the character before he or she makes the decision to become an adventurer.

**+1 Bonuses to Skills:** These are in addition to your normal beginning skills and bonus skills for high Intelligence, and do not count against future skill choices gained at higher levels.

**+1 to A Class-related Skill:** A +1 to either of the two skills received as beginning skills. This does not affect bonus skills.

**Family Heirloom:** If an orphan, is received from a friend or companion. Clerics receive a handsomely carved club. Northman clerics use such wooden clubs carved with runes as holy weapons.

### Character Building Table Notes

Certain experiences have a dramatic effect on a character's personality. This table indicates the one experience that had the *greatest* effect on the character's personality.

Sometimes the impetus for change comes from within the character. For those who resolve to change their ways, think of it as an important New Year's Resolution—an old tradition among the Northmen.

### Combat Experience Table Notes

A beginning character may have been involved in fighting before he or she becomes an adventurer. Northland magic users generally avoid combat situations, while fighters eagerly seek them out.

A "war" on this table does include full-scale campaigns. "War" also includes action in the minor but persistent feuds between vengeful clansmen.

"Raid or Small Action" indicates a single, isolated incident—anything from repelling a raid on a farm to beating off bandits ambushing traders.

### Important Past Experiences Table

Roll 4d6. Fighters: -3 to roll. Magic Users: +3 to roll.

Abilities cannot be raised or reduced beyond the scores noted on the table.

1	Complete Dedication: +1 Strength, +1 Constitution (each, maximum 16)
2	Brutal Schedule: gain +1 to any two different skills
3	Hard Training: +1 Strength, +1 Constitution (each, maximum 15)
4	Training Accident: -1 Dexterity
5	Learn to Concentrate on Work at Hand: +1 Intelligence (maximum 15)
6	Patient Practice: +1 Dexterity (maximum 16)
7	Generous Teacher: +1 Constitution (maximum 15); +1 to any skill
8	Sincere Effort: gain +1 to any class-related skill
9-19	No Benefit
20	Competent Teacher: gain +1 to any class-related skill
21	Good Advisor: +1 Wisdom (maximum 15)
22	Meet a Famous Priest: gain a healing potion; +4 Reverent
23	Good Health, Good Environment: +1 Strength
24	Learn Bad Habits: -1 Intelligence (minimum 12)
25	Access to Good Library: +1 to Intelligence (maximum 15)
26	Inherit Heirloom: gain +1 dagger (Cleric: +1 club) with <i>continual light</i>
27	Fundamental Insight: +1 to Intelligence (maximum 16); +1 to any skill

### Character Building Table

Roll 1d20. No trait can be raised above 15 or reduced below 6 by this table.

1	Betrayed by a Close Friend: Loyal -2
2	Humiliated and Thrashed by a Bully: Peaceful -2, Forgiving -2
3	Widely Praised for a Small Achievement: Modest -2
4	Cheated by Fast-talking Acquaintance: Trusting -1, Generous -1
5	Inspired by the Actions of a Spiritual Hero: Reverent +3
6	Mocked for Timid Behavior: Courageous +1, Cautious -3
7	Discouraged by Poor Luck: Energetic -1, Cautious -2
8	Achieve Success by Misleading a Comrade: Honest -1, Loyal -1
9	Protect a Friend from an Attack: Loyal +1, Courageous +1
10	Defend the Honor of a Family Member: Loyal +1, Courageous +2
11	Lose Several Opportunities Through Hesitation: Cautious -1
12	Forgive a Miscreant Who Becomes a Close Friend: Forgiving +2
13	Get Caught in a Complicated Lie: Honest +1, Cautious +1
14	Ignore a Personal Principle, with Disastrous Results: Dogmatic +2
15	Accidentally Injure an Innocent Person: Cautious +1, Peaceful +2
16-20	Resolve to Change Your Ways: Alter any single trait score 1 point.

### Combat Experience Table

Roll 4d4. Fighter: -3 to roll. Magic User: +3 to roll.

No trait or ability may be raised above 15 or reduced below 6 by this table.

1	War Veteran/Seriously Injured: -2 Constitution, -1 Strength
2	War Veteran/Uninjured: +2 Courageous, -2 Peaceful
3	War Veteran/Injured: +1 Courageous, -1 Constitution
4	War Veteran: Little Danger: +2 Courageous
5	Raid or Small Action Veteran/Injured: +1 Cautious, -1 Constitution
6	Raid or Small Action Veteran/Uninjured: +1 Courageous, -1 Peaceful
7	Raid or Small Action Veteran/Little Danger: +1 Courageous
8-17	No combat experience
18	Injured in Combat: -1 Courageous, -1 Constitution, +2 Cautious
19	Badly Injured in Combat: -3 Courageous, -1 Constitution, +3 Cautious

## NAMING NORTHLAND CHARACTERS

Northlanders have two names: a given name (the common name they are known by), and a family name.

Family names are usually formed by adding the suffixes -son or -sen ("son"), or -dottir ("daughter") to the father's name. Thus, Rolf, son of Ingolf, is Rolf

Ingolfson; Ingrid, daughter of Ingolf, is Ingrid Ingolfsdottir. Some Northland families take their names from revered ancestors or important locations, a less common but quite respectable practice. Many Northlanders are best known by their colorful nicknames. Nicknames can refer to a person's home domain—Sturla of Nemmen, for instance. Other nicknames refer to feats or features the person

is proud of. Thus, Rolf Ingolfson might introduce himself as Rolf the Sea-Wolf, or Rolf of Kroken.

Use the following lists of names as resources and inspirations. Don't hesitate to create your own colorful nicknames to fit the background and personality of your character.

### Male Names

Aethelweard	Aslak	Einar	Gest	Hallkel	Hoskuld	Knute	Rhorvald	Stein	Thorhall
Aki	Atli	Eindrini	Gilli	Harald	Hrafn	Kolbein	Rognvald	Steinkel	Thorir
Alf	Aun	Eirik	Gizur	Harek	Hrapp	Kolskegg	Rollo	Steinthor	Thorkell
Alfgeir	Bardi	Eldgrim	Glum	Hastein	Hrethel	Lambi	Ronik	Strybjorn	Thormod
Alrik	Beowulf	Elrik	Godfred	Hauk	Hring	Ljot	Runold	Strykar	Thormond
Amundi	Bergthor	Erik	Gorm	Havard	Hroald	Ljotolf	Runolf	Sturla	Thorolf
Anlaf	Bersi	Erlend	Grani	Heardred	Hrolf	Lodin	Rurik	Sumarlidi	Thorstein
Anskar	Bjarni	Erling	Grim	Hedin	Hrothgar	Mord	Saemund	Svan	Thorvald
Ari	Bjorn	Eyolf	Gudmund	Helgi	Hrut	Njal	Sam	Svart	Thrain
Arinbjorn	Bodvar	Eysteinn	Gudrun	Hemming	Hygelac	Odd	Sighvat	Svein	Thrand
Armod	Bork	Eyvind	Gunnar	Hengist	Illugi	Ofeig	Sigmund	Sven	Tosti
Arnfinn	Botolf	Fhorgeir	Gunnbjorn	Herijar	Ingald	Ogmund	Sigred	Thjodolf	Tryggvi
Arngrim	Brand	Finn	Gunnlaug	Herjolf	Ing	Olaf	Sigrid	Thjostolf	Ubbi
Arni	Brynjolf	Finnbogi	Guthorm	Hjalti	Ingjald	Olvir	Sigtrydd	Thorarin	Ulf
Arnlaug	Bui	Fjolnir	Guthum	Hjorleif	Ingolf	Onund	Sigurd	Thorbjorn	Vagn
Arnor	Bunnbjorn	Floki	Hafgrim	Hjort	Isleif	Orm	Sigvaldi	Thorbrand	Valgard
Arnulf	Buri	Flosi	Hakon	Hogni	Ivar	Otkel	Skamkel	Thord	Vandrad
Asgrim	Ceowulf	Fridgeir	Hakon	Holgi	Kalf	Otrygg	Snorri	Thorfinn	Vermund
Askold	Egil	Gardi	Halfdan	Hord	Kari	Ottar	Sokki	Thorgerd	Vestein
Ask	Eilif	Geir	Hall	Horik	Karlsefni	Ozur	Solmund	Thorgest	Vigfus
		Geirmund	Halldor	Hormstein	Ketil	Ragnar	Solvi	Thorgil	Volund
		Geirstein	Hallfred	Horsa	Knut	Rhorleif	Starkad	Thorgrim	Ynvar

### Female Names

Aelgifu	Groa	Ragnhild
Alfdis	Gunnhild	Rannveig
Alfhild	Gudrid	Rhora
Arnora	Gudris	Sacunn
Asa	Gudrun	Siglinde
Asfrid	Gunnhild	Sigrd
Asgerd	Gyda	Svala
Asleif	Halldis	Thjodhild
Asta	Hallfrid	Thora
Astrid	Hallgerd	Thorbjorg
Aud	Hallveig	Thordis
Bera	Helga	Thorfinna
Bergljot	Herdis	Thorgerd
Bergthor	Hild	Thorgunna
Brynhild	Hildigunn	Thorhalla
Bunnvor	Hlif	Thorhild
Dotta	Hrefna	Thorkatla
Elsa	Hrodyn	Thorunn
Elva	Ingibjorg	Thurid
Erika	Ingigred	Thyra
Freydis	Ingirid	Thyri
Gerloc	Ingunn	Tosti
Gjafaug	Jorunn	Tovi
Grima	Katla	Unn
Grimhilda	Ragna	Valgerd
		Vigdis
		Yrsa

### NICKNAMES

Bag-Nose	Paunch-Shaker	the Fecund	the Quiet
Bare-legs	Pin-Leg	the Fisher	the Rascal
Beard	Rattler	the Flayer	the Raven
Black	Scale-Clatterer	the Fool	the Red
Bloodaxe	Serpent-Tongue	the Fosterer	the Seal
Blue-Tooth	Silk-Beard	the Gentle	the Shabby
Buttered-Bread	Skull-Splitter	the Golden	the Short
Cod-Biter	Smooth-Tongue	the Good	the Slender
Fine-Hair	Swarthy-Skin	the Grey	the Stone
Fish-Hook	Swift-Sailer	the Hairy	the Stout
Flat-Nose	Tree-foot	the Handsome	the Strong
Forkbeard	War-Tooth	the Hook	the Stubborn
Goat-Shoe	Wry-Mouth	the Huntsman	the Tall
Grey-Cloak	Wry-Neck	the Killer	the Thrall
Hairy-Breeks	the Bitter	the Lean	the Unruly
Half-troll	the Braggart	the Learned	the Wealthy
Hard-mouth	the Broad-Shouldered	the Lesser	the White
Hard-Sailer	the Candle	the Mighty	the Wild
Hare-Foot	the Clerk	the Old	the Winged
Heath-Cock	the Crow	the Overbearing	the Wise
Horse-Head	the Deep-Minded	the Pale	the Worrier
Iron-Wood	the Dragon-Slayer	the Peaceful	the Yeoman
Iron-Side	the Dueler	the Peacock	the Young
Lace-Cuff	the Easterner	the Pickled	
Long-Leg	the Fat	the Pious	
		the Powerful	
		the Priest	

# Clerics of the Northern Realms

## Clerics in the Northern Reaches

A cleric in the Northern Reaches is called a "godri" (plural "godar"). There are three types of godar: household godar, monastic and temple godar, and itinerant godar.

**Household Godar:** A community's cult leaders are usually housed and provided for by the clan leaders. The godar maintain a shrine accessible to the public for the whole community, as well as a private shrine for the use of the master's household. The head godri is available when needed in his host's hall.

**Monastic and Temple Godar:** For various reasons, certain places become associated with individual Immortals. The Stones of Sky, a circle of rune-inscribed standing stones, are said to have been inscribed by Odin himself. There is also Thor's Anvil, a solitary bald granite hill northwest of Sudorn in Vestland, where Thor is said to have shattered the Chains of Deceit forged for Loki by the Modrigswerg masters, Brokk and Sindri.

Often a community of godar will establish sacred retreats in these holy places for contemplation and worship, and for service to the Immortal's followers. These retreats are called "monasteries" because, like the monks of the southern continental cults, the godar of these communities renounce their ties with the outside world—clan, family, and friends—to dedicate themselves wholly to the service of the Immortal.

Throughout Vestland, and in larger towns like Soderfjord Beach and Castellan, all Northland cults have established temples modeled on the sacred precincts of Immortal cults in other D&D® game cultures. This is a recent and "modern" development, and the practice has not spread to Ostland nor to rural or frontier districts. Northland temples are similar to temples all over the D&D game Known World, in that most have a resident staff of godar dedicated to the service of the cult, its followers, and its divine patrons. Adventurers should note that

most godar of higher levels—those capable of casting *raise dead*, for example—are usually household godar serving the chief of a clan, and are not to be found in local temples, as is the case in most other D&D® game communities. This can present problems for adventurers seeking to get a party member *raised* in a territory where the clan and clanhead are unfriendly.

**Itinerant Godar:** These priests serve two purposes for their cults. First, they serve the needs of cult members in remote areas where there are no temples or monasteries, and no clanhold or village godar. Second, they serve as agents of their cults, watching out for the interests of their spiritual brothers and seeking the information, treasure, and diplomatic power that ensure the steady growth and security of their cult.

## Shrines to the Immortals

In addition to formal temples, shrines are common throughout the Northlands.

**Hearth Shrines:** Reverent cult members maintain household hearth shrines. In a poor house, it may be no more than a slab of stone by the fire, where small offerings of food are made at mealtimes. In a wealthy jarl's house, it may be an elaborately carved wood or stone altar where the Immortals are honored, or where coins or war trophies might be dedicated to a patron Immortal.

Since personal practices vary, polite guests are careful to observe and follow the lead of one's host. Failure to make offerings, or making offerings to the wrong Immortal, can cause a guest embarrassment or worse.

**Roadside Shrines:** Throughout the Northern Reaches, small roadside shrines are constructed and consecrated by itinerant godar. Usually they are simple, made of wood or soft stone, and engraved in clerical runes. The runes can be devotional messages, wise sayings, or accounts of historical and legendary events that occurred nearby. It is customary to make

small offerings of spare food, weapons, or other useful gear at these shrines. In desperate circumstances, a cultist may take what he needs from these shrines.

Of course, these remote shrines are seldom guarded, and there is nothing to prevent non-cultists or simple thieves from pilfering objects from these shrines. It is said, however, that the Immortals remember such insults, and any honorable observer will certainly chastise a person so mean as to steal from a shrine.

## Observances and Obligations

There's an old saying in the North—"Gods don't notice, but godar do." If you want something from a godar—shelter, blessing, healing, etc.—make a generous gift. If you are poor, the godar make allowances, so long as you make some gesture. If you are rich—and all adventurers are rich by definition, according to the godar—you are expected to be extra-generous.

Household godar expect to live at the same level of luxury as their noble patrons. Some are more greedy; some are kept in poverty by dishonorable lords.

**Benefits:** The primary benefit of worshipping an Immortal is avoiding his wrath. Northmen are generally a superstitious lot, and much obsessed with the notion of Fate. When something goes wrong, they tend to ascribe their misfortunes to the ill favor of the Immortals. Whether the worship of the Immortals actually helps one avoid misfortune is a topic of lively discussion among believers and unbelievers alike.

In a practical sense, the godar provide great benefits to the individual worshipper and the community. Where the gods do not act, the godar may be more attentive, particularly if properly encouraged with offerings. One important service in the Northlands is the casting of *continual light* on honored family and clan heirlooms, which are thereafter used to light longhouse entrances, hearth halls, and family treasure troves.

In the borderlands, monasteries are centers of trade and communication, and

a source of protection. Monastic godar provide *continual light* for the practical purpose of illuminating remote steads, shelters, and defensive forts against monstrous or human raiders. In return, the monasteries expect substantial donations of food, livestock, and the services of warriors and laborers from the local landholders and clan chiefs.

### Important Northland Immortal Cults

Many Northmen honor all of the Immortals of the Northman pantheon, but most worship some particular Immortal. Worship of each Immortal yields specific benefits of special interest to adventurers. All clerics honoring Northland Immortals know the *interpret rune*, *bless rune*, *know rune*, and *inscribe rune* spells at the appropriate levels, and the rituals associated with those spells (see page 27).

#### ODIN

**Followers:** Worship of Odin and Thor is ordered by royal decree in Ostland. In Vestland and Soderfjord, worship is common among the nobility, less common among the freemen and the thralls.

**Benefits:** An additional bonus of +1 in combat when blessed by a cleric of Odin.

**Obligations:** Honor and obey clerics of Odin and the rightful lords acknowledged by Odin's clerics. In Ostland, followers are taxed one-tenth of their annual income by the Church of Odin.

**Clerics:** Lawfuls and Neutrals.

**Special Abilities:** Instead of the *purify food and water* spell, godar of Odin receive the *read languages* spell. Instead of the *snake charm* spell, Odin godar receive the *spear of Odin* spell (identical to *magic missile*, except instead of an arrow, a magical spear is formed). Godar of Odin are permitted to use the spear, the weapon sacred to Odin, in melee or as a missile weapon.

**Skalds:** Most godar are attached to a patron clan leader or to a place of worship, but many are itinerant travelers and adventurers, seeking to learn wisdom by

observing the affairs of men, and by studying runestones and the songs and verses about gods and heroes. These traveling clerics, called skalds, are popular guests of the rich and poor, repaying their hosts with entertainment, including instructive tale-telling and singing.

**Odin's Ravens:** The clerics of Odin of 7th level and higher may be accorded the special status of being one of "Odin's Ravens." These clerics have the *detect lies* spell and are called upon as judges and counselors when disputes arise. Northmen believe that once the facts of a case are known, a just judgement is obvious to any right-thinking man. Ravens are considered well informed and right-thinking, and are asked to listen to the testimonies of the parties in a dispute (at least two eyewitnesses, or one eyewitness and two reputable character witnesses). Then they are asked to deliver judgement.

There is no means of enforcing a Raven's judgement. Realistically, the Ravens only recommend a judgement and sentence. It is up to the clanheads of those involved to honor the recommendations of the Raven.

In Ostland, Ravens have great power, as the clanheads are greatly influenced by the priests. In Vestland, leaders tend to follow the Ravens' recommendations in spirit, though with considerable freedom of interpretation. In the Soderfjord Jarldoms, the Ravens carry great moral weight, but clanheads commonly delay or ignore the Ravens' judgements when it suits their purposes. In the Jarldoms, justice is whatever pleases the clanhead.

#### THOR

**Followers:** Worship of Thor and Odin is ordered by royal decree in Ostland. In Vestland and Soderfjord, worship is very popular among the nobility and their retainers, but rare among freemen and thralls.

**Benefits:** An additional bonus of +1 in combat when blessed by a cleric of Thor.

**Obligations:** Never refuse combat. Never abandon your comrades-in-arms.

Honor the Warrior's Code (see page 6). Obey clerics of Thor and the rightful lords acknowledged by Thor's clerics.

Actually, most followers of Thor are fairly sane, and will refuse combat or abandon a comrade when to do otherwise is obviously suicidal. Nonetheless, a follower of Thor would feel shamed by those circumstances, and would swear mighty oaths to Thor promising to atone for his or her weakness with deeds of exceptional fearlessness.

**Clerics:** Lawfuls and Neutrals.

**Special Abilities:** Godar of Thor receive *berserk* and *fist of Thor* spells at second level instead of *snake charm* and *speak with animals*. Godar of Thor prefer the hammer, a weapon sacred to Thor.

Most clerics are attached to a patron clan leader. Adventuring clerics of Thor are generally attached to a war band or adventuring party. Clerics of Thor scorn merchants, townfolk, and farmers, and are only found in the company of warriors and noble chieftains. Thor clerics think of themselves as fighters, "just one of the boys," and show little interest in scholarship, fine speech, table manners, or human decency.

#### Berserk

(2nd level clerical spell)

Range: Touch

Duration: 10 rounds

Effect: One follower of Thor or Odin

Affects character touched or self. The subject gains one extra attack per round for 10 rounds. When spell ends, the subject is exhausted for 3 turns, with the following penalties: all attackers gain a +2 bonus to hit; the subject's AC is calculated without a shield (subject is too weary to use it); and the subject's movement is reduced by half. Two or more spells may affect the subject in sequence. Penalties for a berserk-exhausted subject are temporarily deferred by use of another *berserk* spell, but each use means 3 full turns of penalties as noted.

#### Fist of Thor

(2nd level clerical spell)

## Clerics of the Northern Realms

Range: Touch  
Duration: 10 rounds  
Effect: One weapon

This spell gives a magical bonus to weapon damage: +3 for war hammer (the weapon sacred to Thor), and +1 to all other weapons and to unarmed combat. Weapon, or fist (if unarmed combat) touched by the cleric glows magically, and permits damage to magical beings as with enchanted weapons.

### Frey and Freyja

**Followers:** Worshipped by freemen and thralls throughout the Northern Reaches.

**Benefits:** A bonus of -1 AC when blessed by a cleric of Frey/Freyja.

**Obligations:** Observance of the daily and seasonal rituals honoring the deities—typically prayer with small offerings and sacrifices of food or other possessions.

**Clerics:** Lawfuls or Neutrals.

**Special Abilities:** Clerics of Frey/Freyja are druids, with the abilities and restrictions of that class.

Almost every homestead and hearth has a small shrine to Frey/Freyja, and every meal or special occasion is accompanied by thanks for their generosity and protection. Most of these clerics are residents of rural communities and towns, but many travel the roads and wilderness trails, offering blessings and aid to isolated followers.

### Loki

**Followers:** Worship is outlawed in Ostland, and disliked but tolerated in Vestland and the Soderfjord Jarldoms. Most common among thieves, outlaws, and other social outcasts.

**Clerics:** Chaotics.

**Special Abilities:** May receive reversed forms of clerical spells at 1st level (normally learned only at 4th level and above). Public worship is extremely rare; the few established Loki cults are hidden and secretive. Loki clerics are usually the itinerant type, and they habitually travel in disguise. Known for their charity and sympathy with outlaws, criminals, cow-

ards, and other social outcasts, Loki clerics are despised by many for their dubious moral character; they have a reputation for treachery, deceit, and glib fast-talk. However, Loki clerics are not automatically untrustworthy, despite their poor reputations.

### Hel

**Followers and Clerics:** Few and secretive outlaws, limited to practitioners and servants of the necromantic arts. This is an NPC class of clerics not open to player characters!

Godar of Hel receive the *animate dead* and the *speak with dead* spells at second level, the reversed version of *cure serious wounds* (*cause serious wounds*) at third level, and the *raise dead* spell at fourth level. Clerics of Hel also may *control undead* instead of *turn undead*, using the same game mechanics as *turning undead*, D&D® Basic Player Book, page 25. Controlled undead will obey the cleric just as if he had created the undead with the *animate dead* spell.

Worship of Hel is universally considered evil, and is outlawed throughout the Northern Reaches. Only in the Jarldoms, where the central government is extremely weak, will rumor or even public demonstration of Hel worship not automatically result in the trial and banishment of the individual. This is particularly true if that individual is wealthy, or has powerful friends. Temples and cult rituals are secretive and hidden.

### Raise Dead

As noted above, godar who are capable of casting *raise dead* are not located in the temples. Even when a cleric can be convinced to cast the spell, there will be much moral resistance. A person who has been raised from the dead is a subject of fear and loathing among the Northmen; such beings are considered a form of undead. On the other hand, heroic undead are not uncommon among legendary adventurers.

The spirit remains with the body for 4d6 hours. After that period, the spirit is claimed by the Valkyries or by the ser-

vants of the Queen of Hel. A *raise dead* performed before the spirit is taken will work, although the character is looked upon as a ghost or supernatural figure. Thereafter, any raising of the dead is a matter of negotiation with the Immortals.

A Northman fighter or cleric (and sometimes a dwarf) who dies gloriously in battle is taken up by the Valkyries to Valhalla, an Outer Plane of the Northland Immortals. This is a great honor. That character may henceforth be available for special adventures, sent by the Immortals to aid mortal friends. Clerics wait one day before raising such a character in order to see the will of the Immortals. If after a day the character's body has not been claimed, it is considered proper to raise him.

The spirits of other characters who die go to Hel, another Outer Plane. There the characters can only be rescued by questing to the Outer Plane of Niflheim, to the Court of Hel, there to petition the Queen of Hel or to try to rescue the spirit by guile or heroic valor.

### Rune Magic

"The runes are there, for any fool to read," Onund proclaimed. "But only he who has Hung on the Tree, as did Father Odin, one who has gazed on the Abyss and suffered its emptiness, may know their true meanings or tap the Power that lies within."

"Yah, sure. Save that priest-doodle for the peasants," Helfdan scoffed pleasantly.

Saru the Serpent picked a bit of fluff from his mead. "Well, my ignorant, ill-tutored friend, they do say the runes were given to Man by the Immortal Odin All-Father. The legends suggest that the Immortal 'died'—'hung on the tree,' they say. Through the experience of death, through gazing on the incomprehensible void, Odin gained some insight into the magical significance and power of the runes."

"Nice of him to go to all that trouble just for you humans, right?" Dwalinn rolled his head from the table and squint-

ed at the candle. "Well, our pal Odin also expects us all to go through considerable sacrifice to share the meaning of the runes. I suppose you've heard those stories of ritual suicides and raising of the dead associated with learning runes? All true. Right, Onund?"

Onund glared at Dwalinn without replying.

"Folk are just dying to learn the secrets of the runes, right?" asked Helfdan, and collapsed in fits and giggles.

Dwalinn blinked at the others in astonishment. "Helfdan made a pun. Incredible. A punning barbarian. What is the world coming to?"

On one level, runes are simply a special form of written language popular among Northern clerics, used particularly for inscriptions in wood, stone, or other hard surfaces. On a higher level, certain special runes known as "power runes" have special magical meanings. With the aid of certain clerical spells, experienced clerics can enhance the power and significance of those runes.

The most common use of runes is in seeking divine guidance and inspiration. The *interpret runes* spell permits clerics to learn an Immortal's will or to gaze into the future.

Another use of runes is for inscriptions on standing stones. Standing stones are freestanding slabs of rock inscribed with a mixture of practical advice and mystical insights concerning great and humble men, the trials they have faced, and the wisdom to be learned from their deeds.

A third use of runes is in enchanting weapons, jewelry, garments, tombs, and items of ritual value. The cleric must use the *inscribe rune* spell to put the power rune onto the object. Runes used in this way create magical items usable only by clerics. The magical properties of a properly inscribed object are activated by the *bless rune* spell. To properly inscribe an object with a power rune, a cleric must have learned that specific rune through the *know rune* spell and the perilous nine-night rituals associated with that spell.

## Rune Spells

The following clerical spells are known at the appropriate levels by all clerics who serve Immortals of the Northland pantheon, and who have the Read Runes skill (if the optional skill system is being used).

### Second Level Spells

#### Interpret Runes

Range: Touch  
Duration: Instantaneous  
Effect: One cleric

Using a specially carved and enchanted set of wooden tiles, the subject can ask the Immortal he serves for guidance on a course of action. The subject casts the spell, addresses his Immortal with the proper ritual phrases, describes the course of action he proposes, then casts the wooden tiles before him. In the tiles the subject reads the answer of his Immortal patron.

The Immortals generally answer in one of the following ways:

- "You have chosen well. You have our blessing." (Good idea.)
- "Your fate is uncertain but you have our blessing." (Well, it's not a terrible idea.)
- "Your choice is unwise. May the fates bless your fortune." (Bad idea. If you try this, you'd better be lucky.)
- "Your choice offends us. May you live to regret it." (Not only a bad idea, but against the principles of your cult. Your patron is not pleased, but might forgive you.)
- "SILENCE!" (Could mean anything from "How could you waste my time with something that dumb?" to "Do that, and you're not only dead, but your ghost will be looking for a new Immortal to serve.")

The DM, of course, has the option to make the Immortal's response take any form he wants, from a single word to a long speech on ethics.

#### Bless Rune

Range: Touch  
Duration: 10 rounds unless otherwise specified  
Effect: One rune inscription

This spell activates a power rune which has previously been properly inscribed on an object by a cleric.

The best-known magical powers of the 24 Power Runes of Odin are listed beginning on page 29. Other powers of these runes might be learned through adventuring. Different power runes may also exist, and these additional runes might be discovered through adventuring.

*Bless rune* activates only one of the various powers inherent in the rune. The spellcaster must specify which power he wishes to invoke before casting the spell, or the spell fails and the rune is not activated.

### Third Level Spells

#### Know Rune

Range: None  
Duration: Nine nights  
Effect: One cleric

Use of this spell permits a cleric to learn one of the 24 Power Runes of Odin, or some other power rune made available by the DM.

To be effective, this spell must be accompanied by the ritual appropriate to the cleric's cult. (See "Rune Cult Rituals" below.) Each use of this spell results in the permanent loss of one Constitution point.

#### Inscribe Rune

Range: Touch  
Duration: Permanent  
Effect: One power rune on one object

This spell permits a cleric to inscribe a power rune on an object. The cleric must know the rune (see the *know rune* spell above) and perform the appropriate rituals (below). Any error or omission in performance of the ritual spoils the spell effect.

Unless inscribed using this spell, a

## Clerics of the Northern Realms

power rune has no magical properties and cannot be activated. Once properly inscribed upon an object, a power rune may be activated by a cleric using the *bless rune* spell.

An object inscribed with a power rune becomes linked to the cleric that performs the ritual and casts the spell. Henceforth the cleric will know whenever the rune is activated by a *bless rune* spell, or when it is destroyed physically (*i.e.*, by destruction of the rune or the object) or magically (*i.e.*, by a *dispel magic* or similar spell). This occurs regardless of distance from the object. The cleric knows nothing of the circumstances of the activation or destruction of the rune—only that it has been activated or destroyed.

There is a limit to the number of power runes a cleric may have magically inscribed at any one time. The total is equal to the number of third level spells the cleric may memorize at one time. If the cleric attempts to inscribe a greater number of runes than his limit, all power runes currently inscribed by him immediately lose their magical properties, and his current *inscribe rune* ritual is spoiled as well. Objects properly inscribed by a cleric retain their properties after his death.

### Rune Cult Rituals

The following rituals are common among the clerics of the Northlands pantheon.

**Interpret Runes:** The 24 Power Runes of Odin must be carved into oak tiles by the cleric who casts the spell. The invocation must respectfully ask for the Immortal's attention and plainly describe the course of action upon which the cleric wishes an opinion.

Some say that elaborately-carved and ornamented tiles are no more effective than crudely-improvised tiles, so long as the runes are clearly and accurately represented. Others claim that only the finest materials and the most skilled craftsmanship are pleasing to the Immortals. *Player Hint:* A handmade set of these tiles can be used as props during game sessions.

**Know Rune:** A cleric who knows the

rune or an object bearing the properly-inscribed rune must be present during the nine day ceremony. A priest who knows the spell must also be present to speak the proper words.

The *know rune* ritual requires the ceremonial (not real) death of the cleric who is to learn the rune. As a consequence, each use of the *know rune* spell results in the permanent loss of one Constitution point.

The cleric is given a potion—a toxin which does not kill, but paralyzes the cleric's mind and body, inducing a death-like appearance. The cleric remains awake for nine days and nights, but cannot communicate, even by mental magic. Cut off from all perception of the world, the unprepared can actually perish in their brush with the madness which results.

In the Odin cult, a ceremonial hangman's noose is placed around the cleric's neck, and then he is buried in a watertight coffin in a sacred bog for nine nights. In the Thor cult, the ceremony is similar, except that the cleric is buried in the earth for nine nights. In the Frey/Freyja cult, the cleric is laid to rest on a ceremonial funeral pyre, which is not lit, where he remains in a trance for the nine days. In the Loki cult, the cleric drinks the potion and is sealed in darkness.

At the end of the nine-night ceremony, the cleric must be awakened from his ritual death. Thus, a *neutralize poison* spell and *cure critical wounds* must be available, at least.

When the character is awakened, at the DM's option a Reverence check may be required. A successful check means the cleric knows the rune he or she sought to learn.

A failure may indicate that the Immortal has chosen to give the character a rune other than the one requested. In some cases, the Immortal gives the cleric a rune more suitable for the Immortal cult served. In other cases the Immortal may assign a rune at random or, occasionally, more than one rune. Sometimes the rune requested is granted, but only upon accomplishment of some task or quest. In rare circumstances, the Immortal gives

the cleric a hitherto unknown power rune (which must be specially created by the DM).

**Note:** Most modern nations of the D&D Known World regard the *know rune* rituals with horror and disgust, because of their nearly suicidal associations. Therefore, these practices are kept secret by Northman clerics, though widely-rumored. This may partially explain why rune magic is not common outside the Northern Reaches.

**Inscribe Rune:** To effectively inscribe an object with a power rune, the object, the cleric making the inscription, and the tools used to make the inscription must be ritually purified and dedicated to the Immortals. The preparations for the ritual require 2d4 hours, and the ritual itself requires 4d6 hours. The preparations and the ritual itself must be performed by the cleric who is to cast the spell and make the inscription. If the cleric is disturbed in any way during the ritual, the ritual is spoiled, and the spell cannot be cast effectively.

### The Standing Stones

Skalds carve freestanding stones by roadsides to commemorate important events and to tell tales of the good and evil deeds men do. The inscriptions on standing stones are left so that those who follow after may learn from the experiences of eyewitnesses inspired by the Immortals. The rune inscriptions may only be read by those who have the Read Runes skill.

Neither the *read languages* nor *read magic* spells permit reading rune inscriptions. The special enchanted nature of the runes is clerical, and is not affected by most magic user spells. A *wish* or *contact outer plane*, however, might be effective, depending on circumstances and the decisions of the DM.

These stones and the runes inscribed upon them are sacred to the Immortals. Tampering with or defacing them is a great sacrilege. Those dedicated to Odin will stop at nothing to avenge a slight to the runestones.



# The 24 Power Runes of Odin

These power runes (pages 29-31) are those best known by Northern clerics and adventurers. All characters can learn to recognize these runes, paraphrase their meanings, and understand their magical functions. Only those inspired by sacrifice and communion with the Immortal (the *know rune* ritual) can understand and reproduce these runes. Unless otherwise noted, player characters get saving throws against rune spells as if against magic wands.

**Other Runes:** There are many other runes of power. These runes are the property of the Immortals, and may be bestowed on favorites.

When encountered, these unique runes cannot be comprehended without special knowledge (such as instructions from the original inscriber, extensive scholarly research, or divine guidance). To invoke the power of a rune, one must understand what different effects the rune may produce and specifically request the one desired effect when blessing the rune.

A desperate godi (priest) might try to invoke a rune which he did not understand. If the godi is a PC, the player should tell the DM what magical effect he is trying to invoke. If that effect is in any way related to the power of the rune, there should be a chance that the rune will be activated.

Normally nothing happens. Occasionally something nice happens. Occasionally something horrible happens. Invoking a rune without specific knowledge of its powers is a chaotic act, and not to be lightly undertaken.

A character may occasionally be given his own personal rune by the Immortals. It is a sign of great favor, and often a sign that a great fate awaits the character. Generally that fate is as much of a curse as a blessing.

## Fehu Cattle

This rune signifies wealth.

Northmen traditionally figure their wealth in terms of how many cattle they own.

1. Indicates the presence of treasure within a radius of 90 feet.

2. Indicates direction to a specifically identified treasure.

3. Shields a treasure from magical detection.

4. Announces the owner of an inscribed object.



## URUR the Auroch

This rune signifies the strength of the wild beast.

1. Causes one hostile wild animal to stand as if hypnotized.

2. Gives the cleric the strength of a bear (Strength 18).

3. Attracts the attention of all attackers within a 30' radius and causes them to attack the cleric instead of other companions (just as the bull auroch challenges a pack of wolves in order to protect the herd).



## THURS the Giant

This rune signifies the various creatures of the giantish races.

1. Causes giantish creatures to have a favorable reaction (+2 to reaction roll) to the cleric.

2. Causes one giantish creature to stand as if hypnotized. Creature may make a saving throw vs. spells each round to overcome compulsion.

3. Cleric grows to the size of a hill giant. Cleric in effect temporarily becomes a hill giant, with all associated abilities and liabilities (including a giant's stupidity and savage, brutal nature). Cleric's clothing and armor may be destroyed by the transformation. Normal human weapons are useless.



## AS the Immortals

This rune signifies the Immortals and their realms beyond the Prime Plane.

1. Reveals the true appearance of magically disguised creatures, particularly demons, Immortals, and various creatures from beyond the Prime Plane.

2. Creates a circle of protection as with a *protection* scroll which prevents demons from entering the circle of protection.

3. Confers a +2 bonus on all saving throws.



## Raibu Journeying

This rune signifies the traveler.

1. For a six hour period, the cleric awakens from sleep if an enemy or creature with hostile intent approaches within 100 feet.

2. If the cleric is lost, or the way is obscured by darkness or bad weather, the cleric senses which direction (but not distance) to travel to reach his destination.

3. For a six-hour period, the cleric receives a +2 bonus to Constitution checks made as a result of fatigue or dangerous weather conditions.



## KAUNNA Fire

This rune signifies the warmth-giving hearth, the light-giving torch, and the destructive power of wild-fire.

1. The rune burns like a torch for two hours, yet does not consume the material the rune is inscribed upon. The fire burns even in heavy rain, but not while submerged.

2. The rune burns intensely for the duration of the spell. If a to-hit roll is made, the victim takes 3d4 damage when struck.



## Gefu Giving

This rune signifies generosity and hospitality.

1. Causes intelligent creatures to respond positively to requests for food, shelter, and clothing (+3 to reaction rolls).

2. Causes hostile or vengeful persons to positively respond to offers of appropriate gifts or weregild as compensation for injury or offense given (+3 to reaction rolls).



## WUNJU Joy

This rune signifies great happiness and appreciation of life.

1. Causes an audience to respond favorably to a tale or song (+2 to reaction rolls).

2. Causes one listener to respond favorably to a request for aid (+4 to reaction roll).

## The 24 Power Runes of Odin

3. Causes all intelligent creatures within 20' radius to temporarily stop fighting. Creatures making a save vs. spells may resist the effects of the rune. Creatures no longer within the 20' radius are no longer affected. Alternatively, the DM may require NPCs to make trait checks to resist effect of rune.

### **H** Hagla Cruel Nature

This rune signifies the violent, destructive side of nature.

1. Creates a single lightning bolt as the magic user spell, but doing only 3D6 damage.

2. Creates a violent, miniature wind and rain storm within a 20' radius, centered on the cleric. Creatures within the area of effect must make Strength checks (or Dexterity checks, if more appropriate) each round to perform actions normally. Failure of the check means no action may be taken within that round. The cleric may take no action other than concentrating on the rune.

### **X** Naudir Desperate Need

This rune signifies great danger and the good fortune needed to avoid it.

1. Permits the cleric to delay the effects of any single physical attack once during the spell. The cleric must indicate avoidance of the attack before to-hit and damage rolls are made. The effects of the attack are delayed until the end of the spell's duration.

2. Permits the cleric to move twice as fast as normal for a single round, once per spell.

3. Gives the cleric a +2 bonus to all saving throws for the duration of the spell.

### **I** Isar Ice

This rune signifies ice and cold.

1. Causes a 10' x 10' water surface to freeze solidly, thick enough to support the weight of a normal man. If formed in rapidly-moving water, the ice becomes an ice raft and floats with the current. At the end of the spell, the ice

melts in 1d10 rounds (regardless of surrounding temperature or conditions).

2. Causes a small hail storm, 10' in diameter, within 60' of the cleric. Creatures within the area of effect take 3d6 damage. Successful save causes half damage.



### **J** Jarn Fruitful Nature

This rune signifies the bounty of wild nature (as opposed to domestic animals and crops).

1. The cleric is informed whether plants or animals are edible or poisonous. (This includes natural plants and animals of outdoor and subterranean environments.)

2. Indicates direction to specific species of plants known by cleric to have medical or magical properties. Maximum range is one mile.



### **I** Ihwar the Hunter

This rune signifies the tracking, snaring, and killing skills of the hunter.

1. Missile weapons (leather sling or wooden bow) inscribed with this rune gain a +2 to-hit bonus.

2. Small traps and snares inscribed with this rune permit the cleric to capture small creatures (maximum 20 pounds) without injuring the creatures. If the species is natural to the environment, the creature will be lured to the snare within 24 hours. If the creature is not natural to the environment, the rune has no effect.

3. The cleric may trace the trail of any creature, regardless of the surface traveled, or physical or magical attempts to obscure the path. Effective only during the duration of the spell.



### **P** Pethru the Unseen

This rune signifies concealment and hidden knowledge.

1. Those within a 60' radius of the cleric fail to notice him as if he weren't really there. Even if observers bump into him or see other evidence of his presence (shadows or objects interrupted in flight), the observers fail to recognize the

significance of the evidence. More distant observers are not affected.

2. Messages written in runes are permanently concealed from view if accompanied by the activation of this rune within the message. The message can only be read thereafter by the activation of another *pethru* rune within line of sight of the concealed message.

3. The cleric is aware of, but cannot see, invisible beings within a 60' radius. The cleric is not aware of direction or distance to the invisible being. The only indication of the being's presence is the brilliant, intensified glow of the activated rune.



### **A** Aigir the Elk

This rune signifies protection.

1. A shield inscribed with this activated rune acts as a +1 magical shield.

2. The cleric receives a +3 to all magical saving throws.

3. A weapon inscribed with this activated rune will automatically parry any one attack during the spell's duration. The player must indicate which attack he chooses to parry before to-hit and damage dice are rolled.



### **S** Sowelu the Sun

This rune signifies healing and good health.

1. One healing spell thrown by the cleric automatically cures maximum possible number of hit points. Rune activation is immediately canceled.

2. Heals the recently dead. Victim loses one point of Constitution permanently and is raised to zero hit points. Victim must have been reduced to negative hit points no more than ten rounds before the rune is touched to the victim, and the victim may not have been reduced below -11 hit points; otherwise, the rune has no effect.

### **Tiwar War**

This rune signifies might and valor in arms.

1. Causes a rune-inscribed weapon to strike automatically and do maximum damage. Rune activation is automatically canceled.

2. Causes the cleric to ignore the effects of magical fear or illusions.

3. Reduces morale of attackers within a 10' radius by one point.

### **Berkana the Birch**

This rune signifies the durable vitality of the birch.

1. If wearing no armor, skin becomes as tough as bark. Armor class is 6. Shield may also be used. Wearing any other armor (including magical armor) negates benefits.

2. Cleric takes half damage from one physical or magical attack. Cleric may elect to take half damage after knowing the damage caused by the attack. Rune activation ceases immediately.

(E)3. Cleric is automatically healed of 10 hit points worth of damage. Rune activation ceases immediately.

### **Ehwar the Horse**

This rune signifies communication with and mastery of horses.

1. Cleric may enter the mind of a horse for the duration of the spell, perceiving as a horse perceives, and with a horse's instincts.

2. Cleric automatically passes all horsemanship skill checks.

3. Cleric may summon a specific horse that is within one mile of the caster. If the horse knows the cleric well and has been well-treated, it will answer the summons immediately: it will arrive as soon as possible, risking combat with other creatures, and risking its life in difficult physical maneuvers if necessary. Otherwise, the horse will take no risks in answering the cleric's summons.

### **Mannar Man**

This rune signifies knowledge and earthly wisdom.

1. The cleric may know the true intentions and basic personality of one stranger.

2. The cleric may search the mind of another human for the answer to one question. If the subject knows the answer, the cleric learns the answer. If the subject does not know the answer, the cleric is no wiser. The more complicated the question, the more uncertain, unreliable, and obscure is the answer the cleric receives.

3. Upon holding an object belonging to another human, the cleric may know which direction to travel in order to find him. The cleric has no sense of distance, only direction. Rune activation ceases immediately.

### **Lagur Water**

This rune signifies protection from drowning and from the power of the sea.

1. The cleric can breathe underwater.

2. The cleric can float on the water's surface, regardless of personal encumbrance. He may also buoy up one other person if the person is not wearing armor (or carrying bricks or something equally silly).

3. An activated rune carved into the prow of a ship protects it from shipwreck for 1D10 turns. It does *not* protect crew members.

4. An activated rune carved into a wooden staff will keep an unencumbered person afloat for 24 hours. It will not protect the person from the elements.

### **Ingwar Growth**

This rune signifies the power of growth in natural things.

1. Causes normal plants to grow to fill a 15' radius hemisphere centered on the cleric. This unnatural growth of natural plants causes the plants to distort, collapse, and intertwine, creating a formidable barrier against attackers or blocking a narrow path. The effect proceeds by increments for the ten rounds of the spell, ending in the final round. The plants remain huge and distorted until they are destroyed or die naturally.

2. Causes a single plant or an object made from plant materials to grow up to five times its original height and twice its original width in one round. The effect lasts for the duration of the spell. Thus a staff, hemp rope, or cotton shirt, as well as a tree

or vine, may be grown to a greater size.

3. Causes a natural animal to grow to twice its normal size in one round. The creature may only move at half its normal speed and dexterity, but its hit points, damage done, and carrying capacity are doubled. The effects last for the duration of the spell.

### **Odala Birthright**

This rune signifies power over the fate ordained by the Immortals.

1. During the ten-round period of the spell, the cleric may permit another creature to ignore the effect of one attack that would reduce it to negative hit points or cause its death by poison or magic.

2. This rune permits the cleric to ignore one attack which normally would reduce him to negative hit points or cause him death through poison or magic. The rune need not be currently activated, but the cleric must bear the rune-inscribed object in his hand and must be able to cast the *bless* rune spell. (That is, he must know the spell, must not have exhausted his 2nd level spells for the day, he must be conscious and able to speak the incantation activating the spell.) This action is performed automatically, regardless of other actions taken by the cleric during that round.

### **Dagar Day**

This rune signifies the powers of light and darkness.

1. This causes the rune to burn as brightly as the sun for ten rounds (bright light, not the sun's heat). All areas within line of sight of the rune are brightly illuminated, up to a distance of 200' from the rune. This magical effect is not affected by reversed *light* or *continual light* spells.

2. This reduces all artificial and magical light sources within 120' of the cleric to 1% effectiveness (*i.e.*, 99% darkness). All attacks are at a -4 penalty.

3. This permits the cleric to see in the dark as with *infravision* (level 3 magic user spell) for the duration of the *bless* rune spell.

Large longhouse private quarters

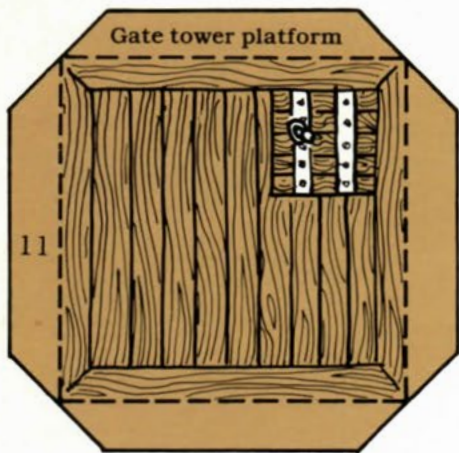

clerics

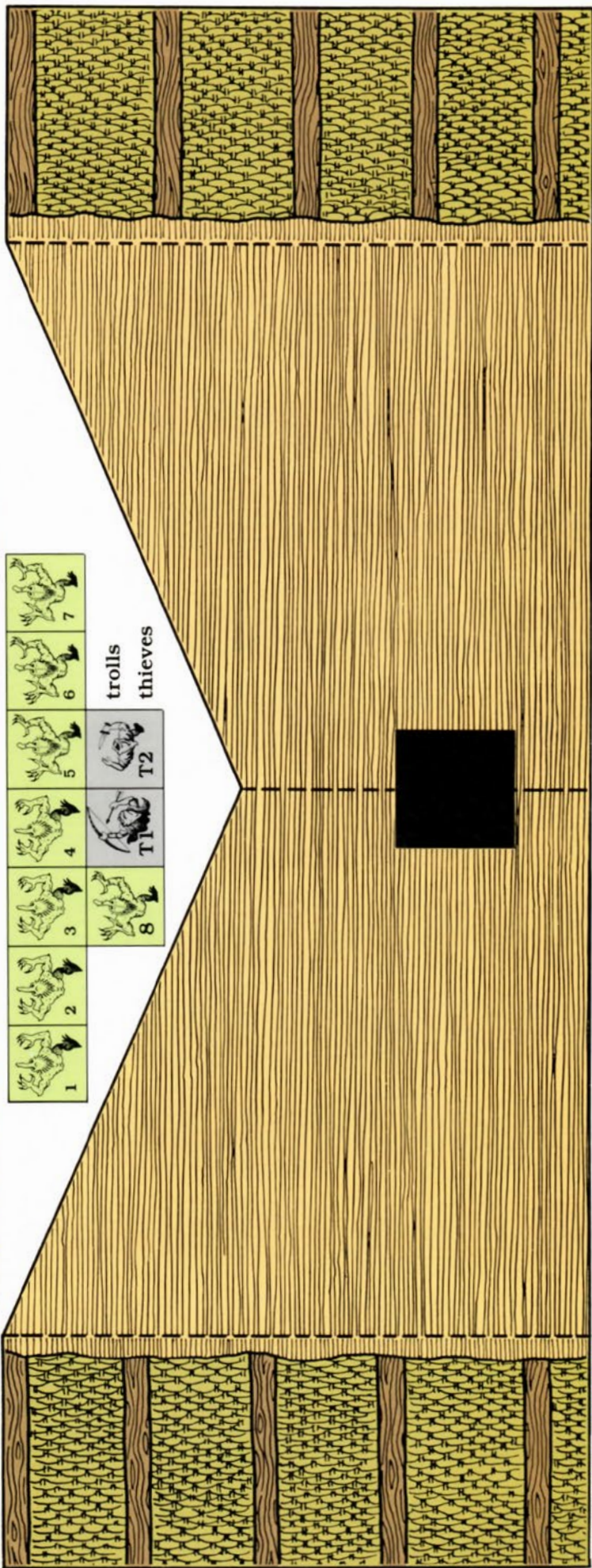
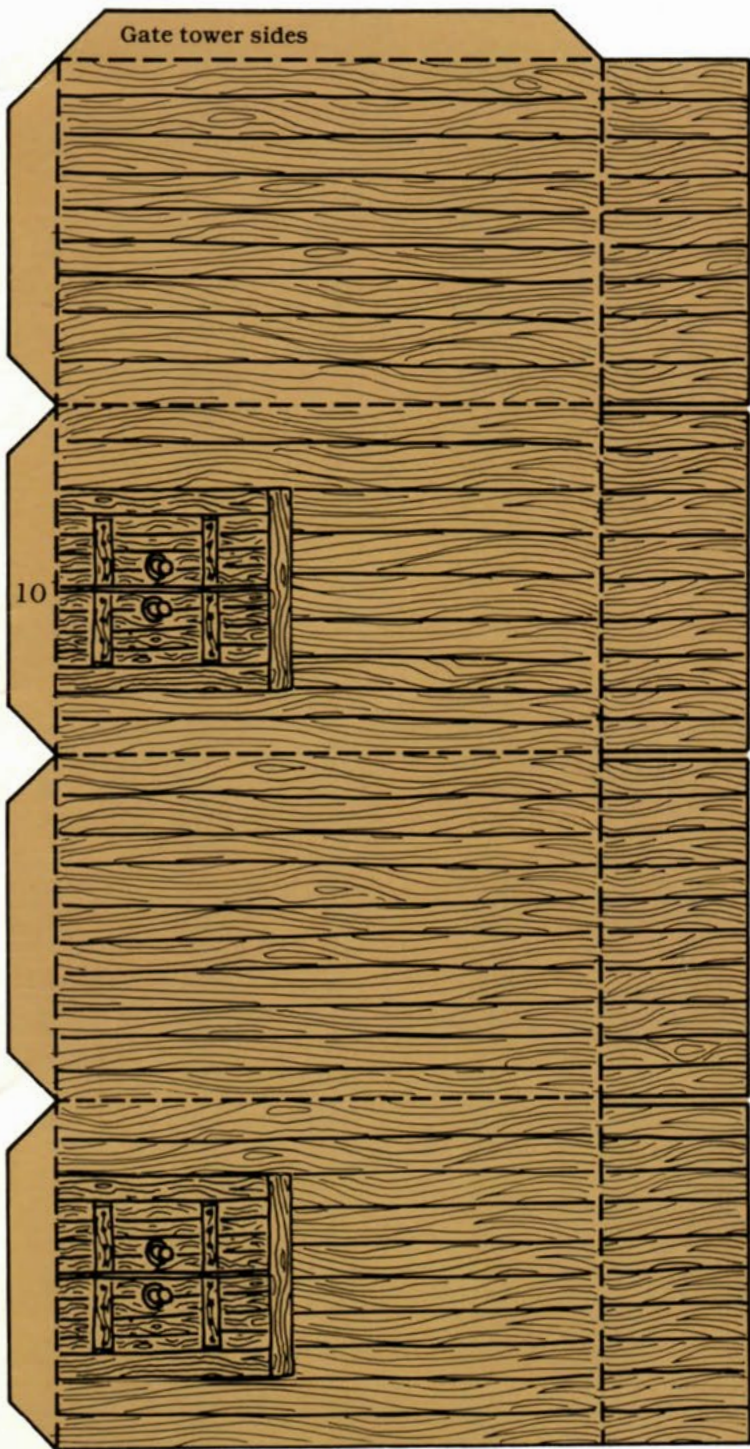

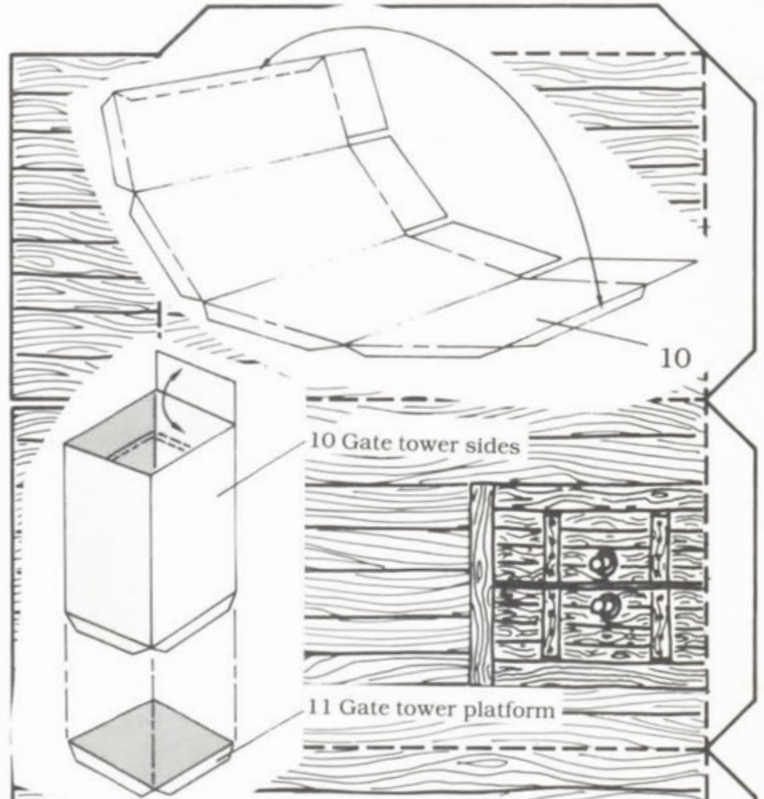
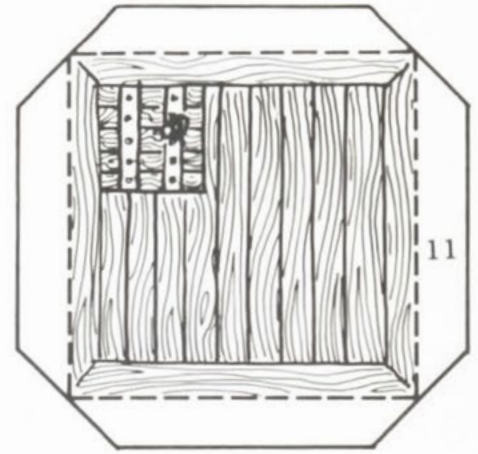
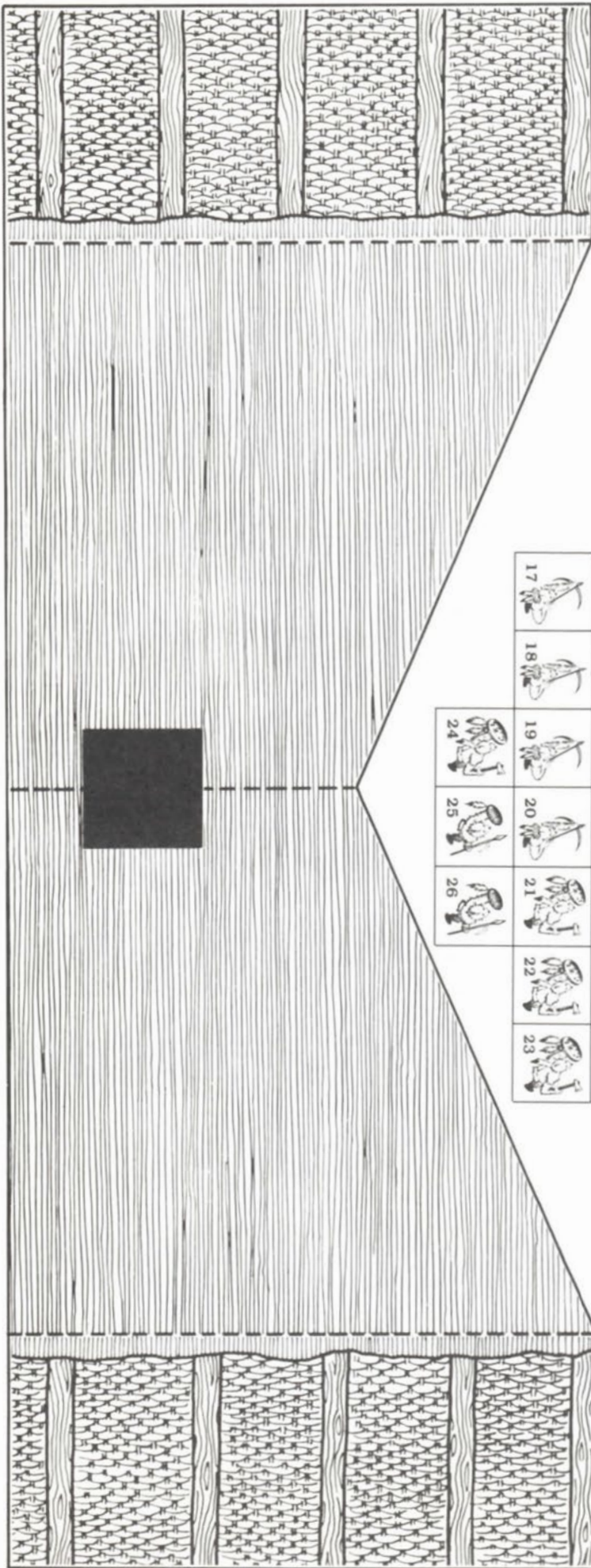

### Gate tower assembly

The gate tower is the most difficult building to assemble. It is designed to support metal miniatures on the platform/parapet. First score the dotted lines, then cut out the two gate tower pieces (10 and 11). Assemble piece 10 first. Fold and glue the sides together. At the top of the tower are flaps that fold inside and are glued to the interior walls. These flaps form the inside of the parapet wall. Leave the flaps at the bottom of the tower for later.

Pick up the platform floor piece. Fold the flaps down and crease them until they almost touch the bottom side of the platform. Push the floor up through the tower so it meets the inside parapet walls. Now, glue the flaps with the help of a pencil. Dab glue on the pencil point and then rub it on the platform flaps. Push the flaps against the tower sides.

The flaps at the bottom of the tower are there to strengthen the base of the tower. Fold them inside and glue them to the inner tower walls.

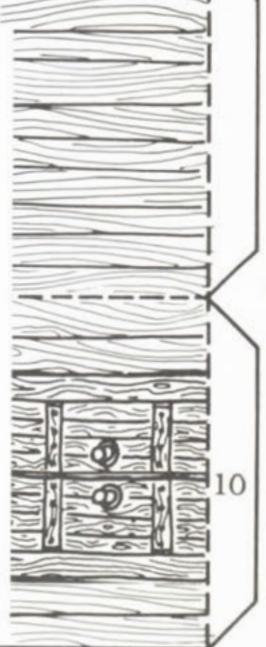

Large longhouse roof and sides

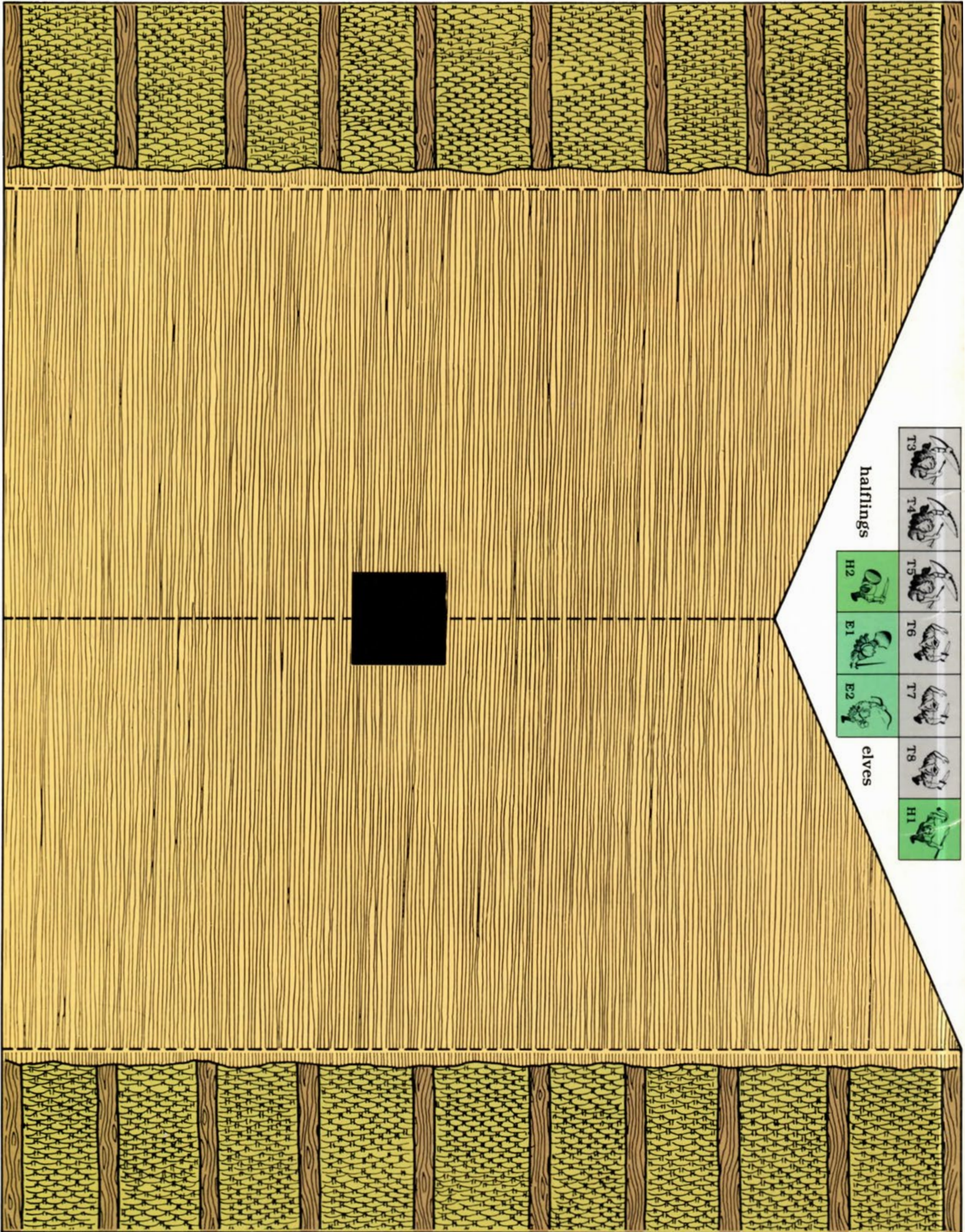

## General Assembly Instructions

1. Solid black lines are the guide lines for cutting out the buildings and counters.
2. Dotted lines show where the buildings fold. Folds are easier to make if the paper has been scored. You can score the paper by using a ruler and a ballpoint pen. Use the ruler to help make straight lines. With the ballpoint pen draw a line on top of the dotted line. Press down hard with the pen. This should push down the top few layers of paper. You may have to draw over the dotted line several times to make an obvious depression in the paper. Be careful that you don't cut through or make holes in the paper. Try scoring on the sheds first.
3. The flaps are always glued or taped to the inside of the buildings. They should not be visible when the buildings are completed.
4. Glue or tape can be used on the flaps. White glue should work well although it needs time to dry. Tape is faster but less permanent. Using both could relieve you from having to hold the glued flaps while the glue dries.



### Longhouse assembly

- 8 Longhouse ends
- 9 Large longhouse ends

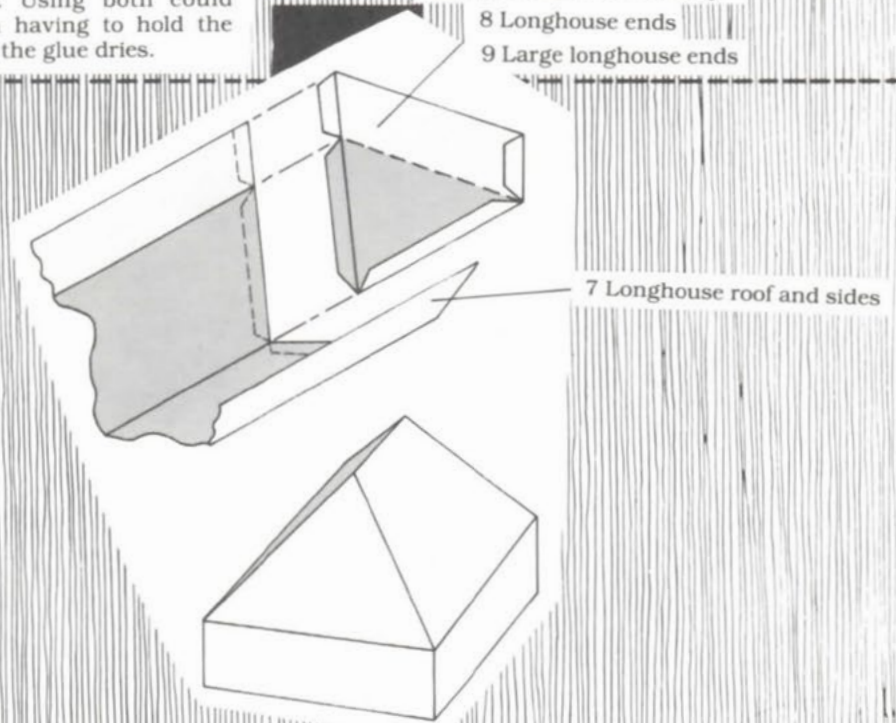

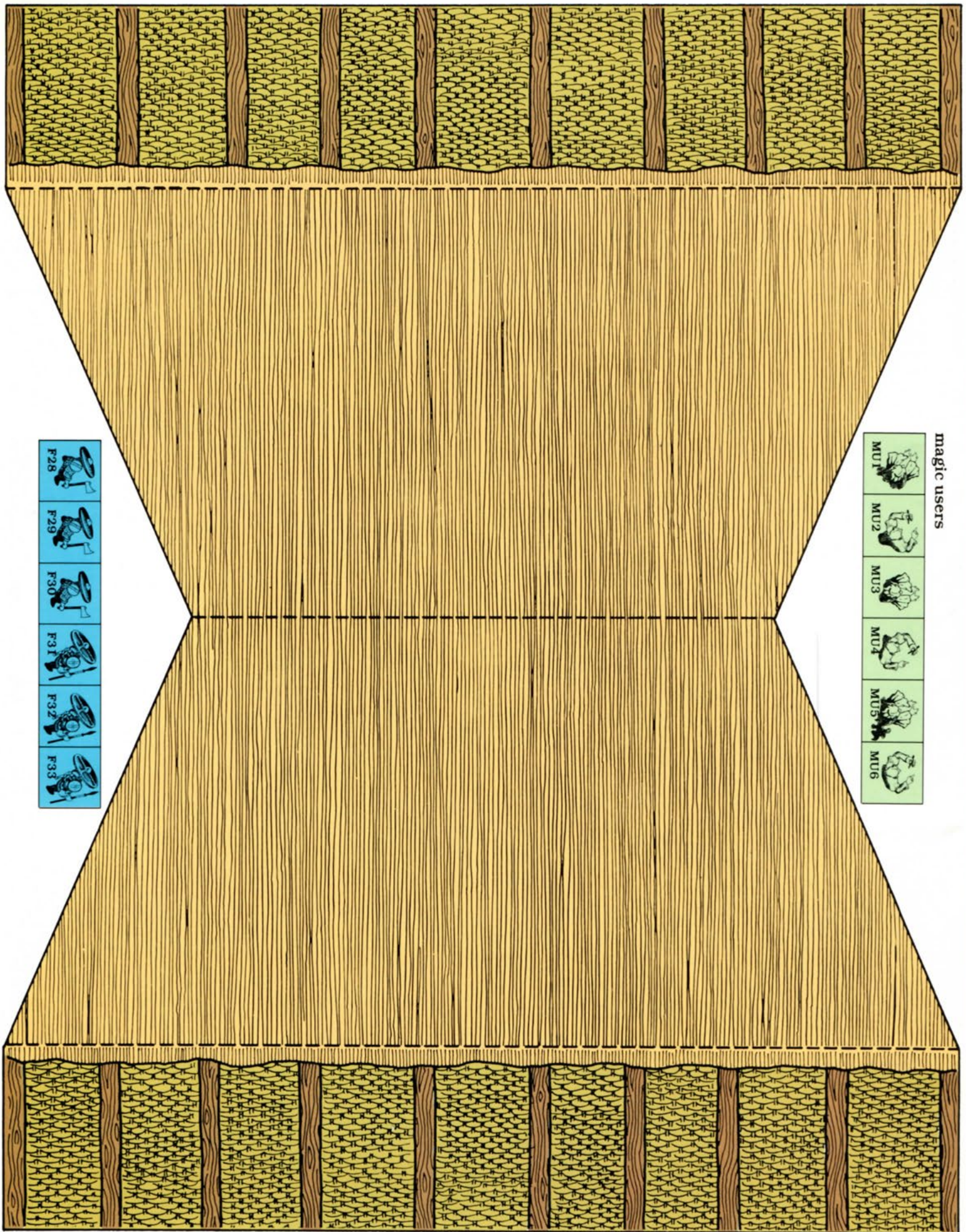



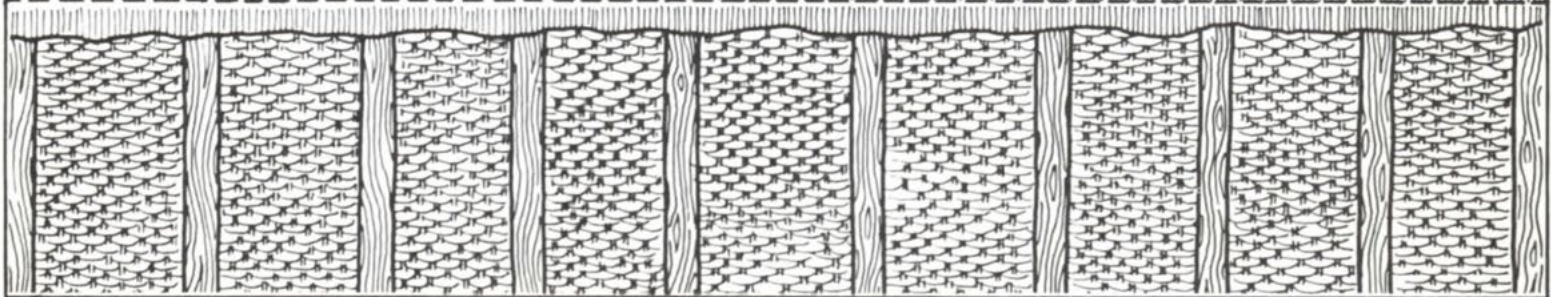
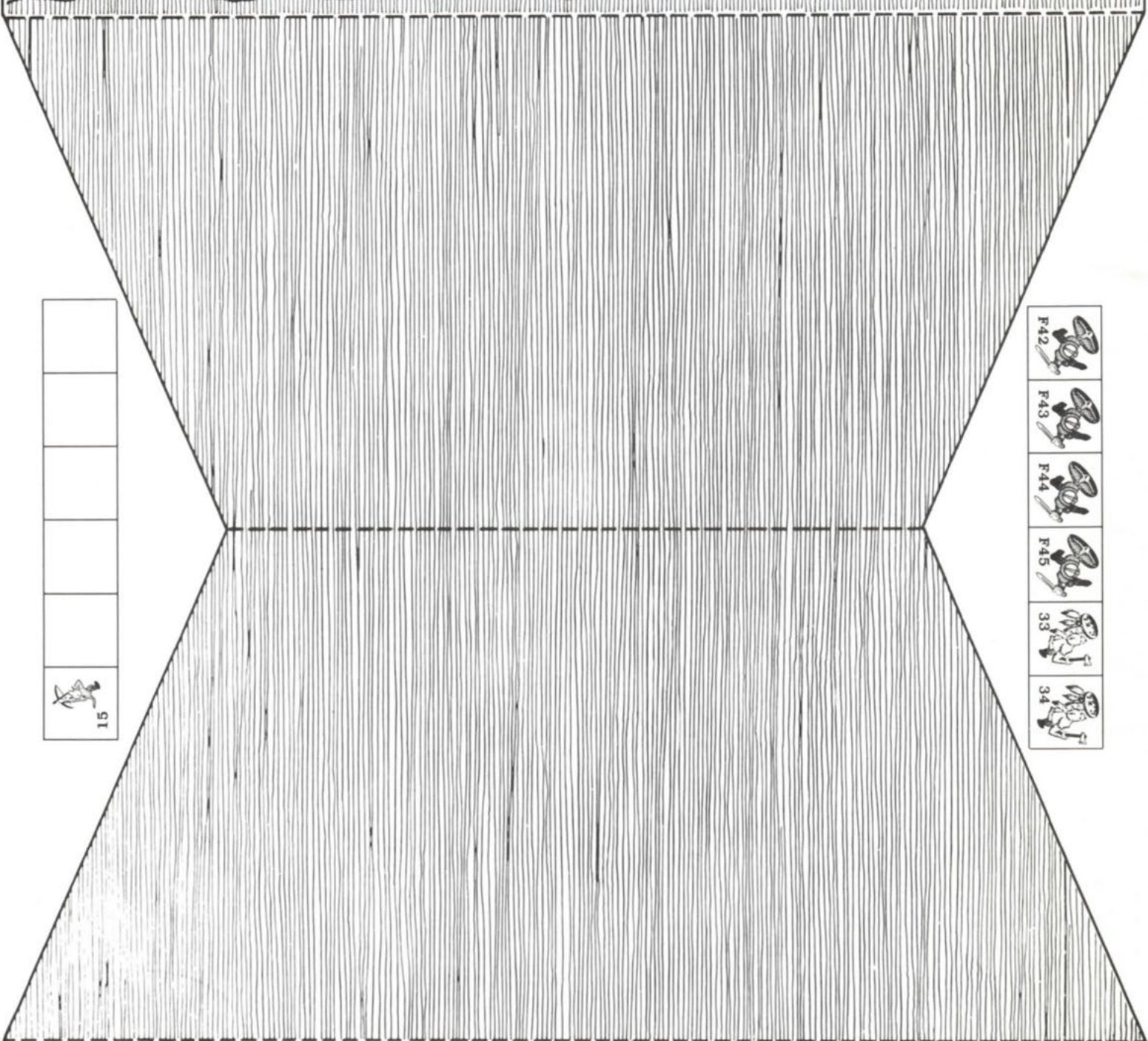
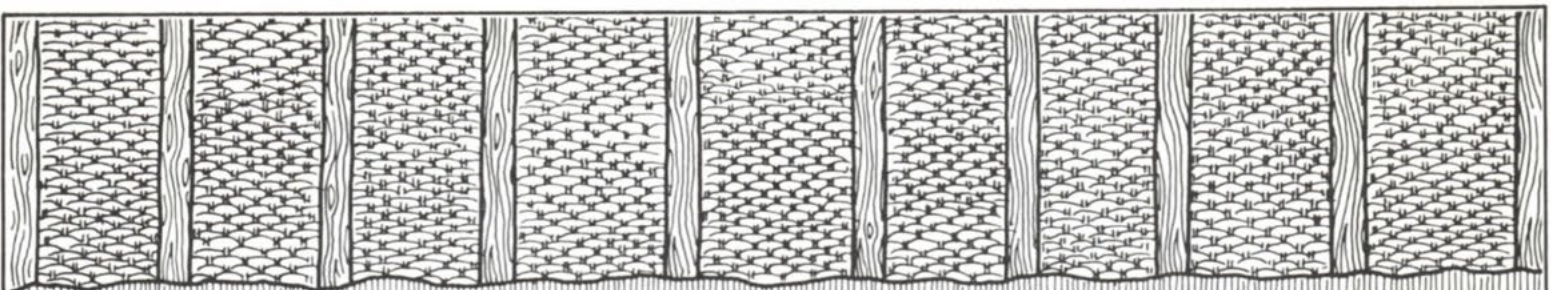

- F28
- F29
- F30
- F31
- F32
- F33

- magic users
- MU1
  - MU2
  - MU3
  - MU4
  - MU5
  - MU6





- F42 
- F43 
- F44 
- F45 
- 33 
- 34 

- 
- 
- 
- 
- 
- 
- 15 

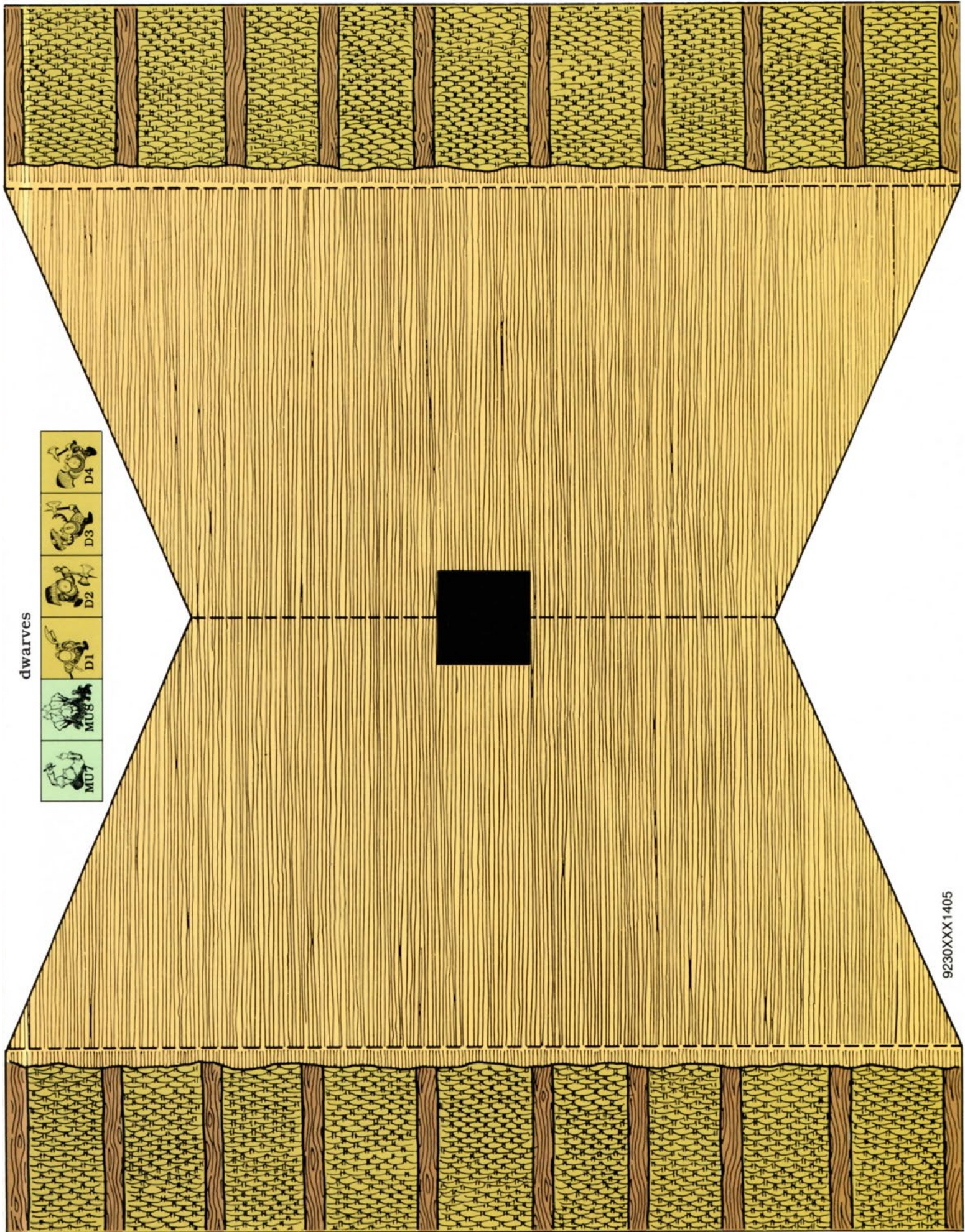

dwarves

-  D4
-  D3
-  D2
-  D1
-  MU8
-  MU7

9230XXX1405

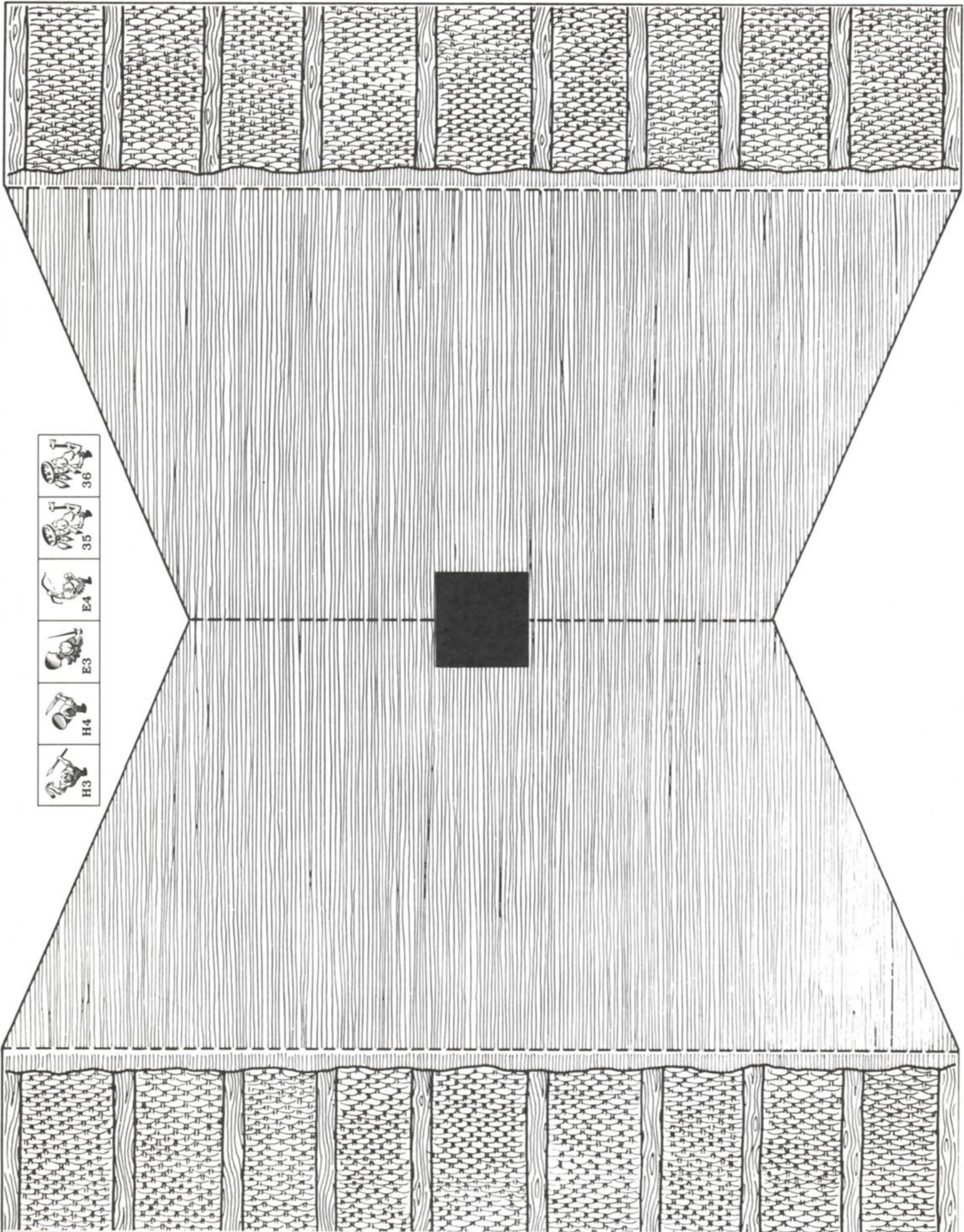

-  36
-  35
-  E4
-  E3
-  H4
-  H3

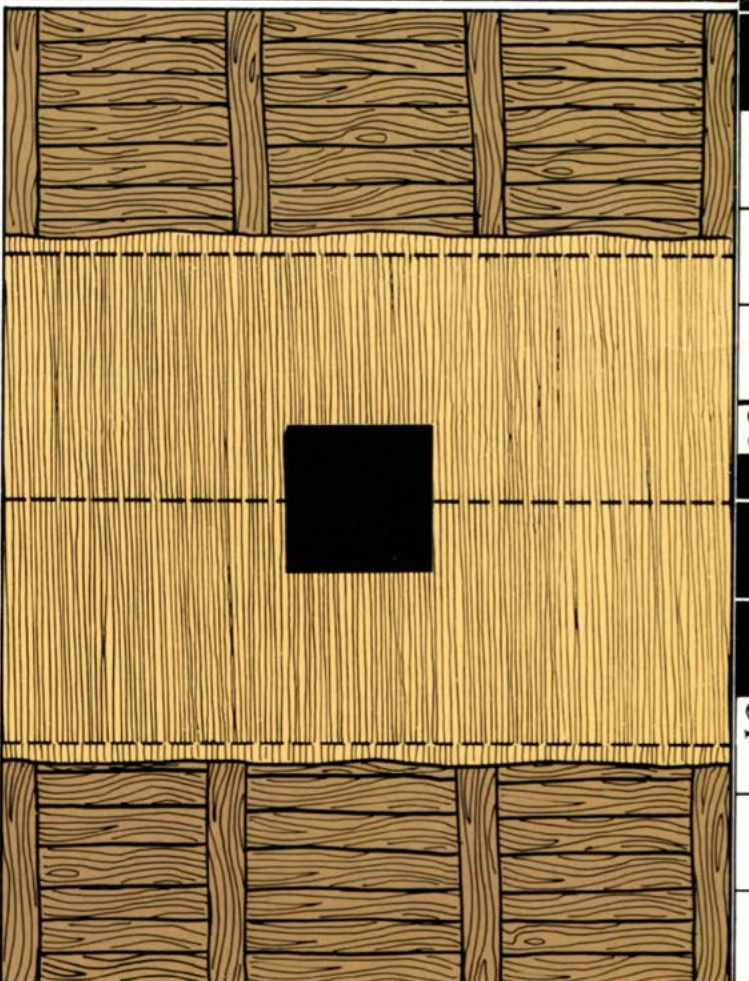
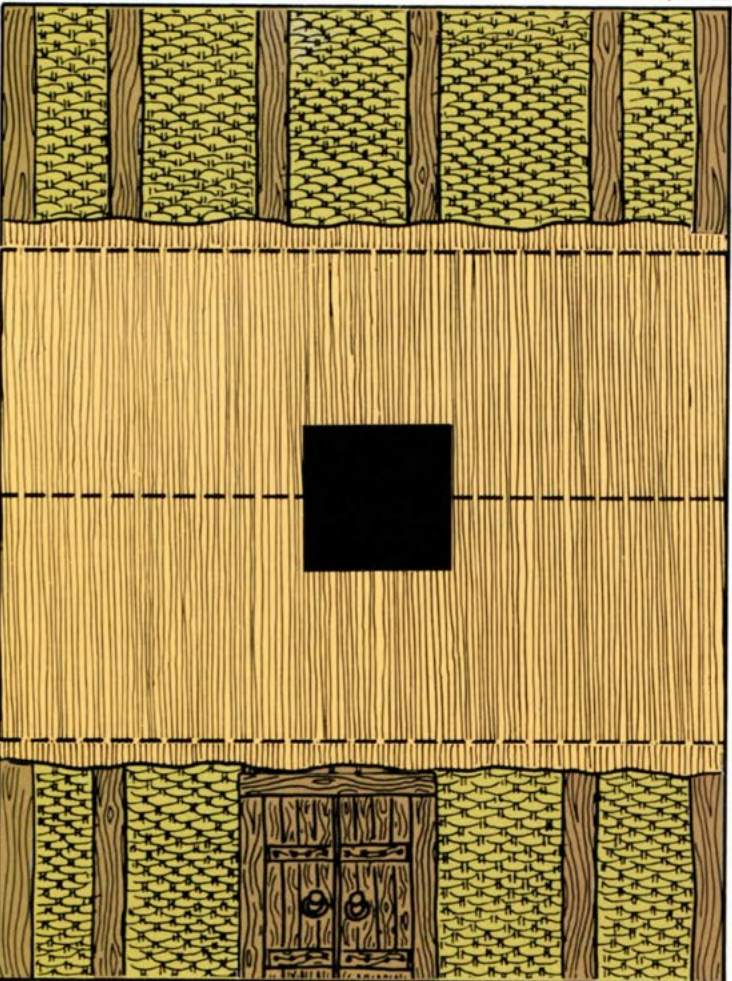
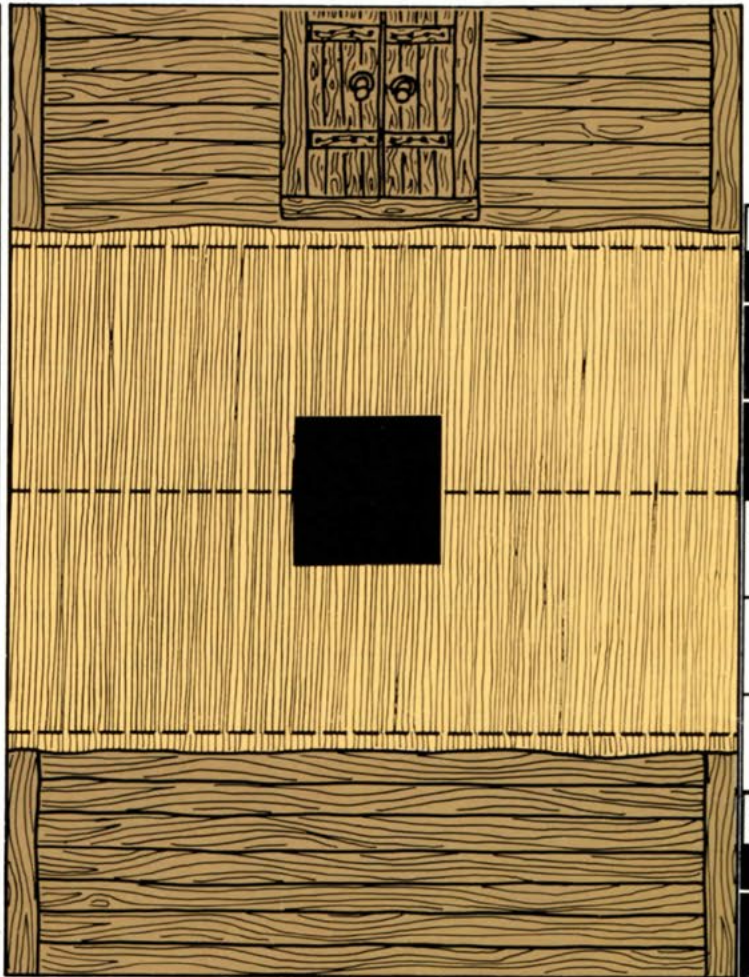
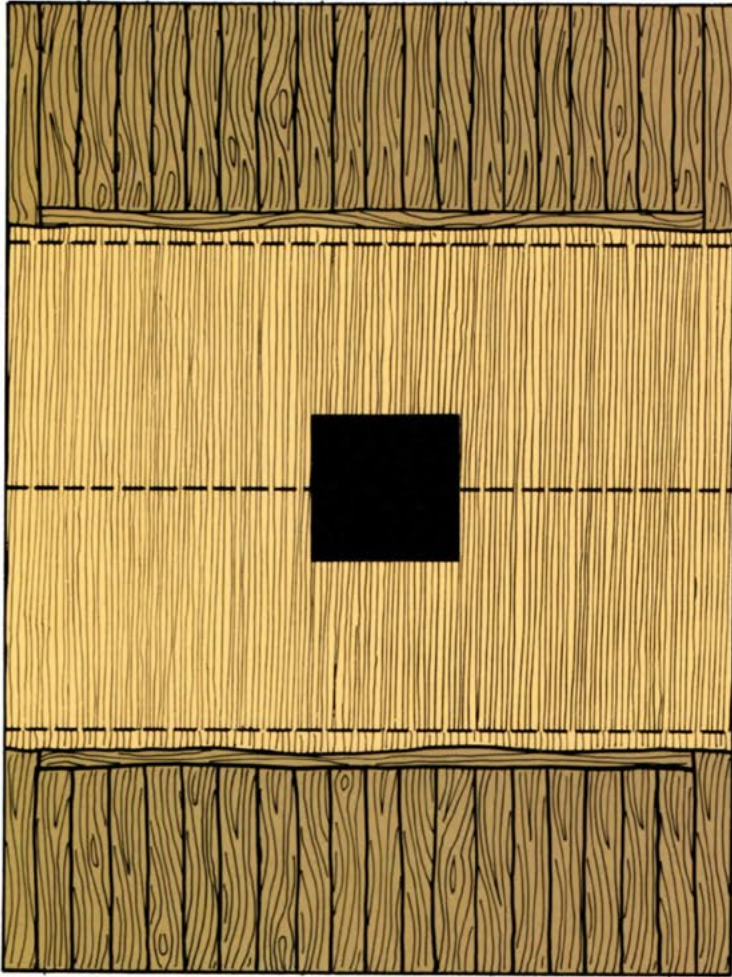

60

50

40

30

20

10

4

20

20

20

20

20

20

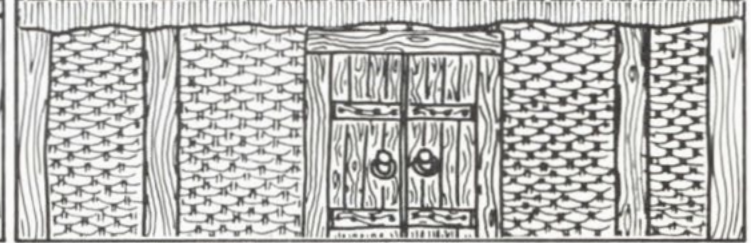
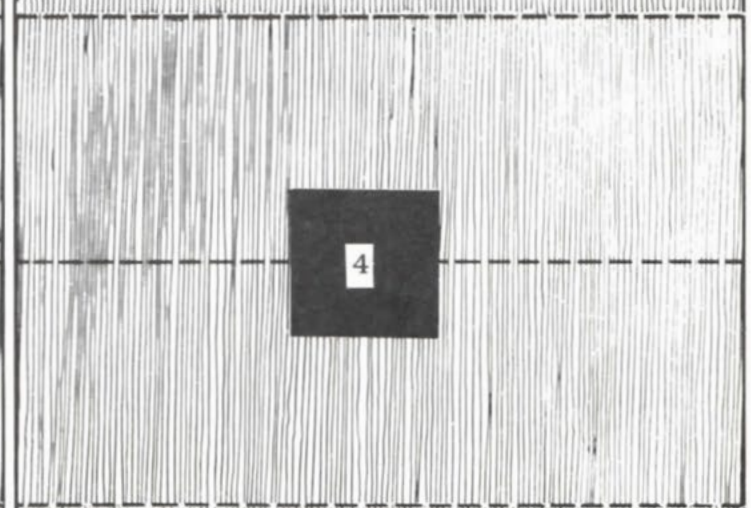
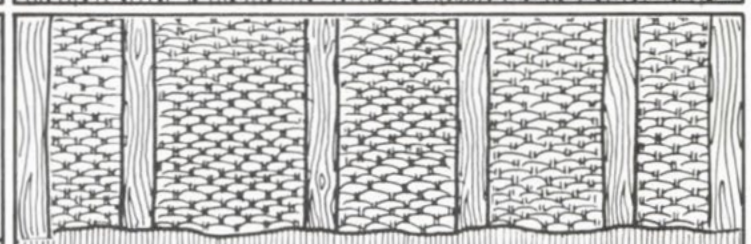
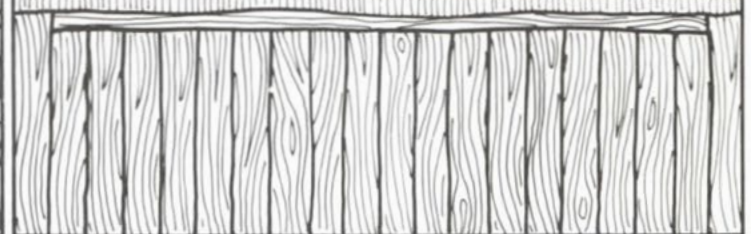
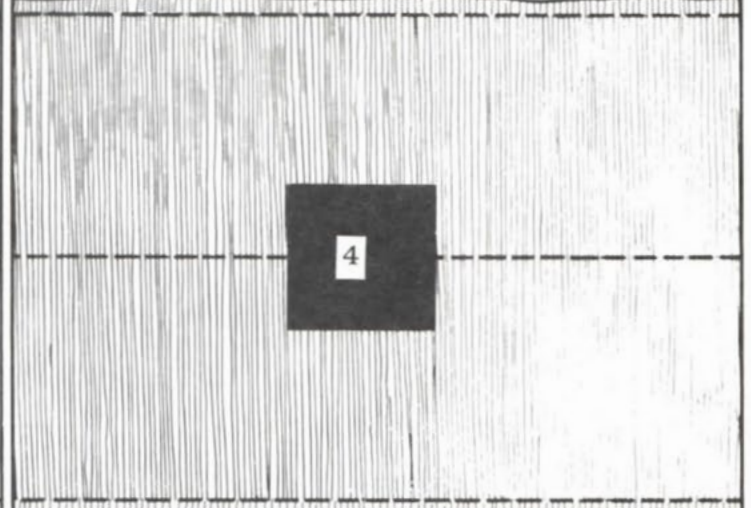
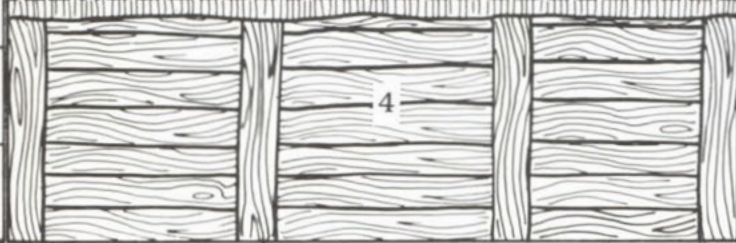
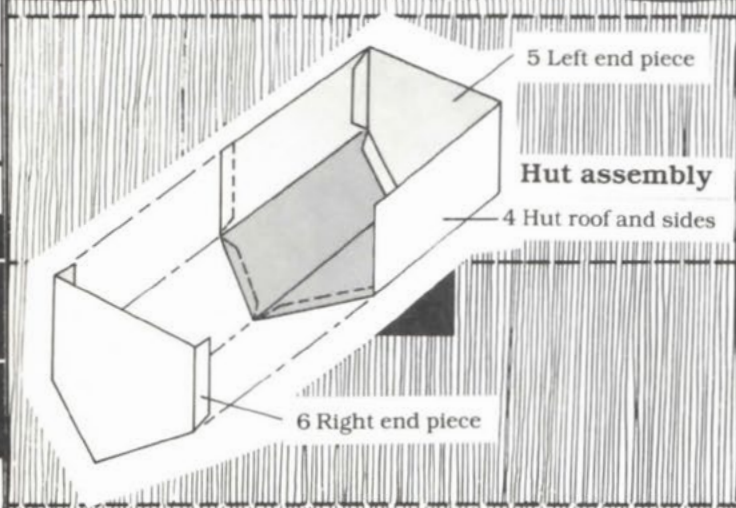
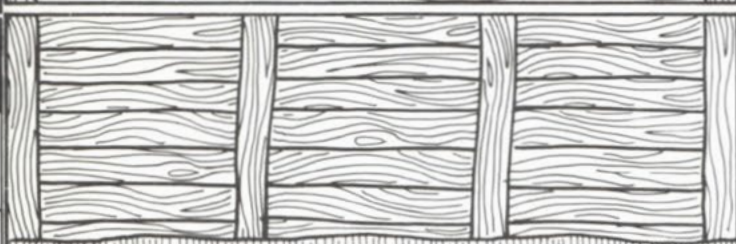
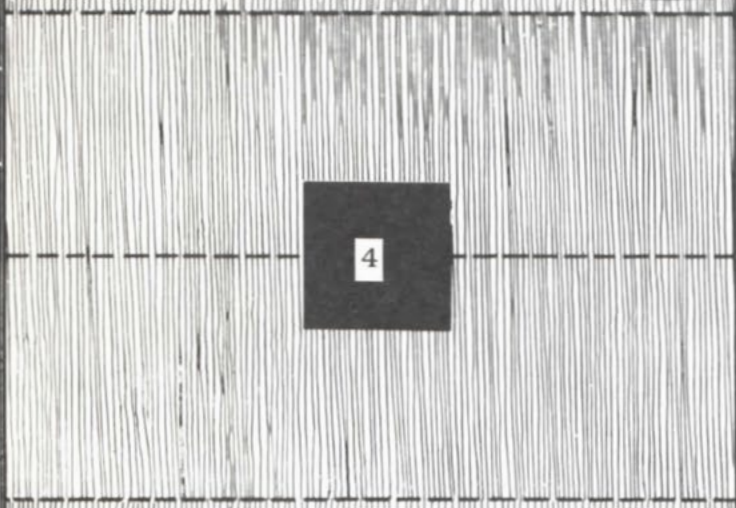

Hut ends



Shed roof and sides 1

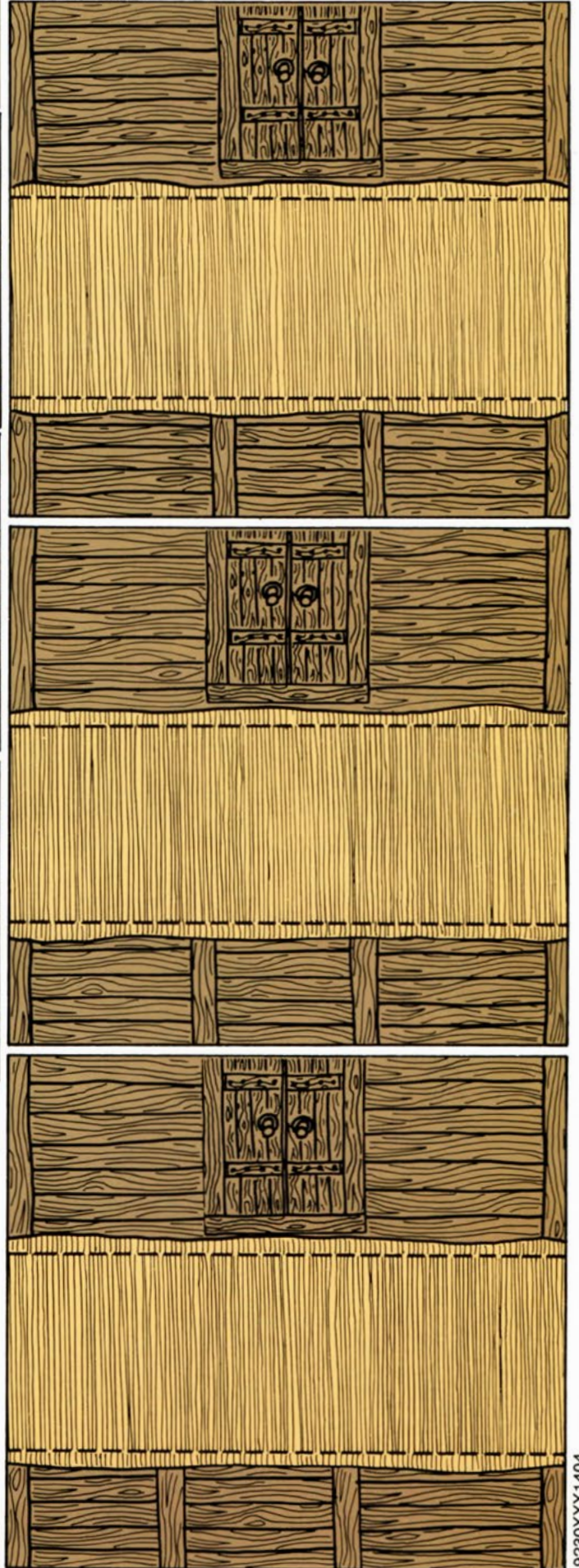
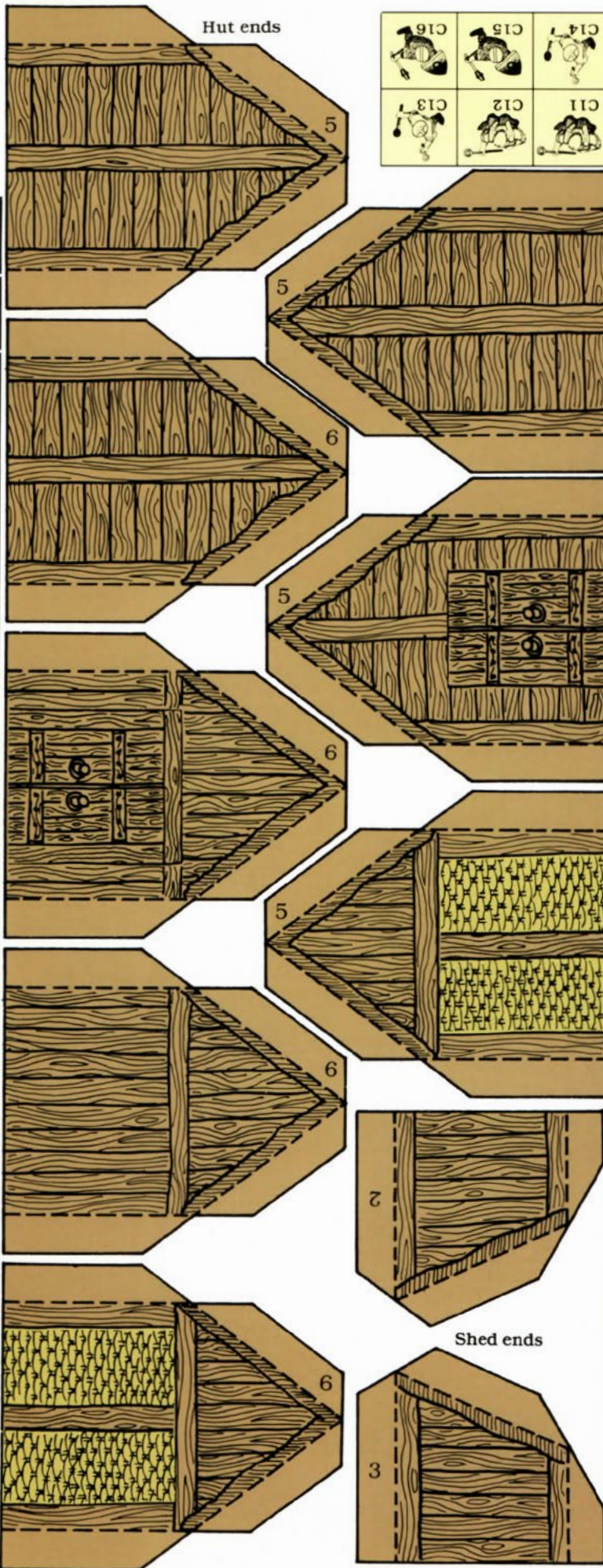

Shed ends

9230XXX1404

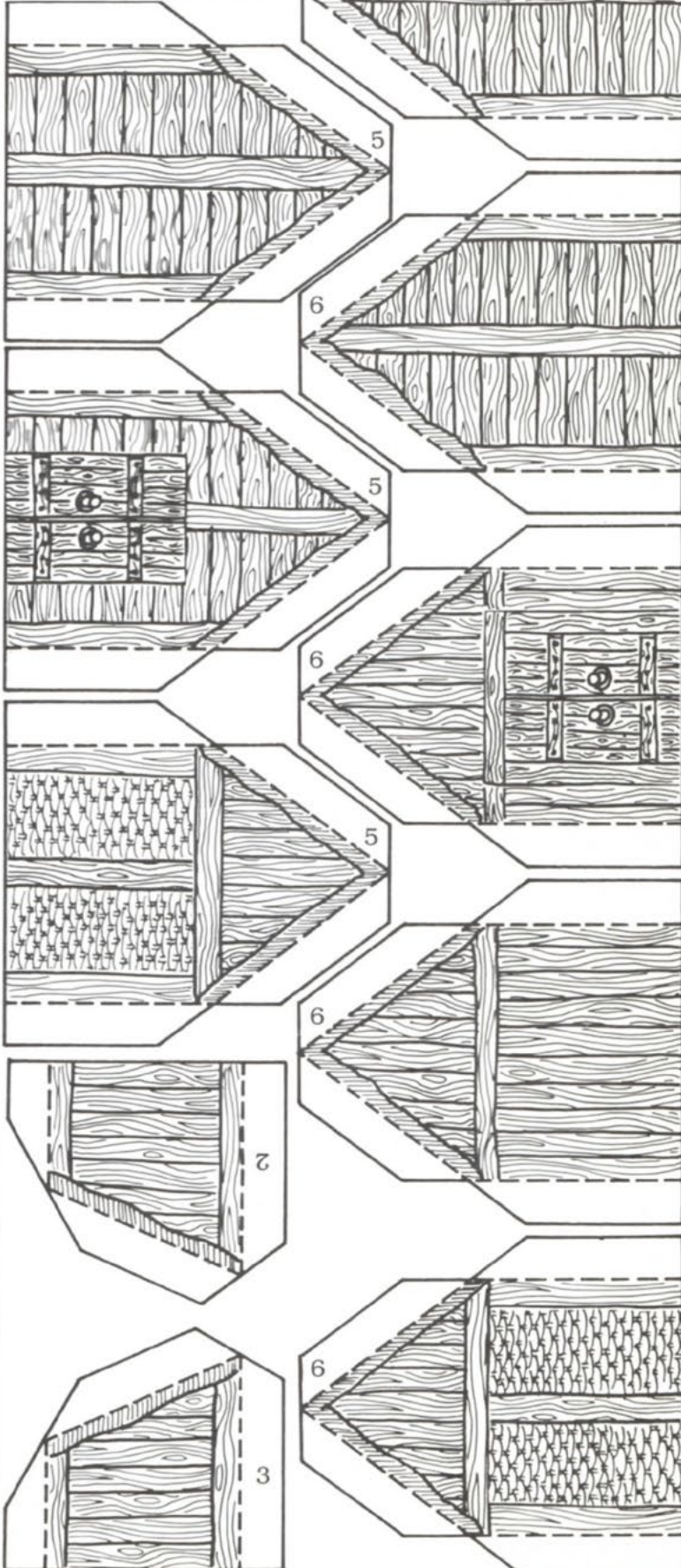
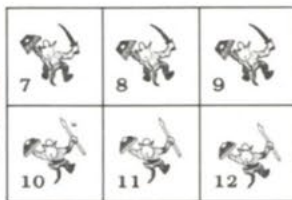
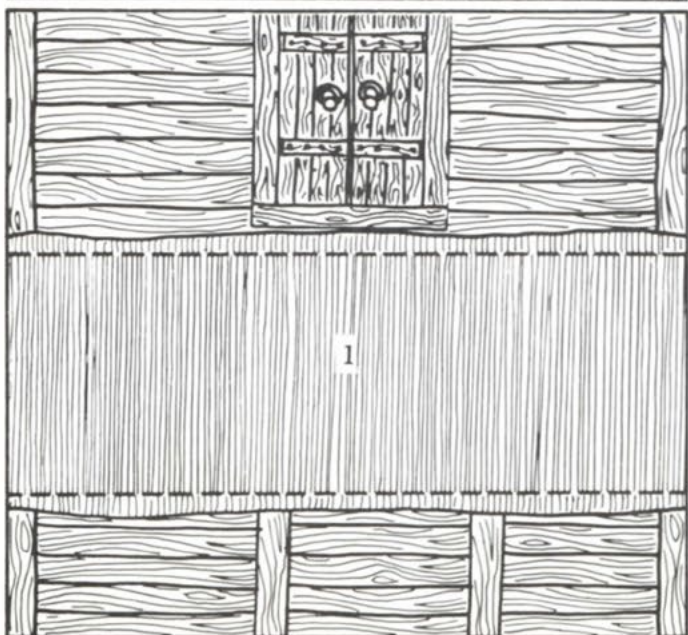
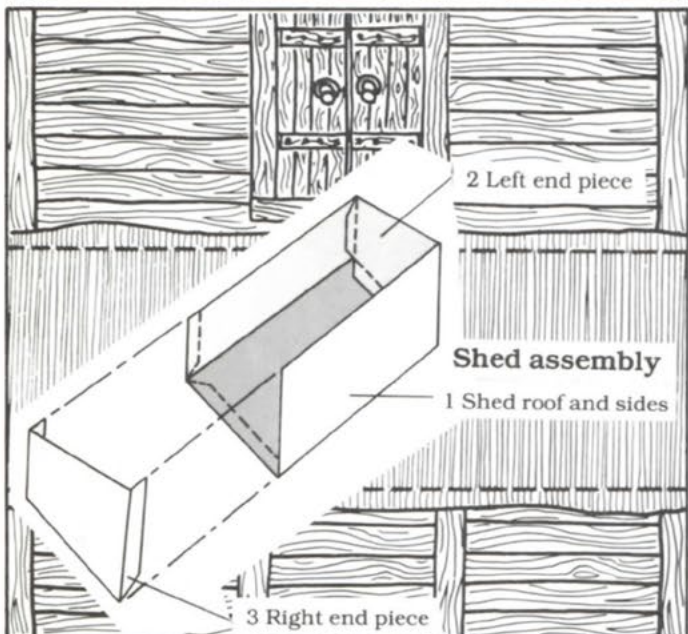

10  
20  
30  
40  
50  
60

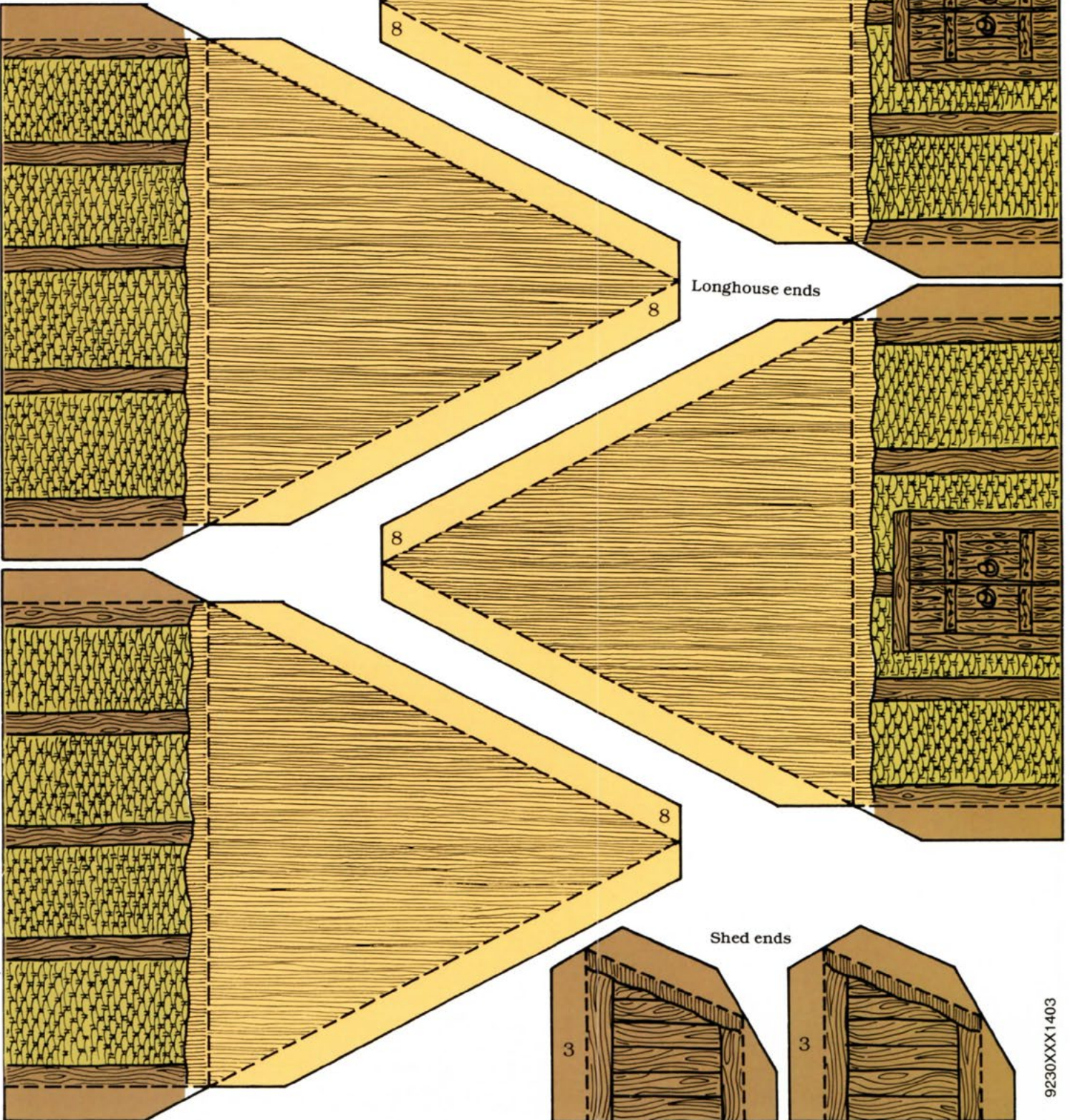
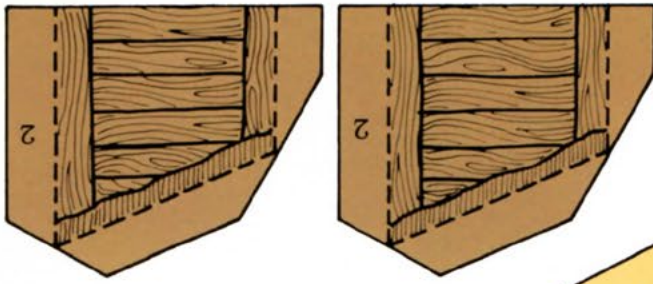

Longhouse ends

Shed ends



20 20 20 20 10

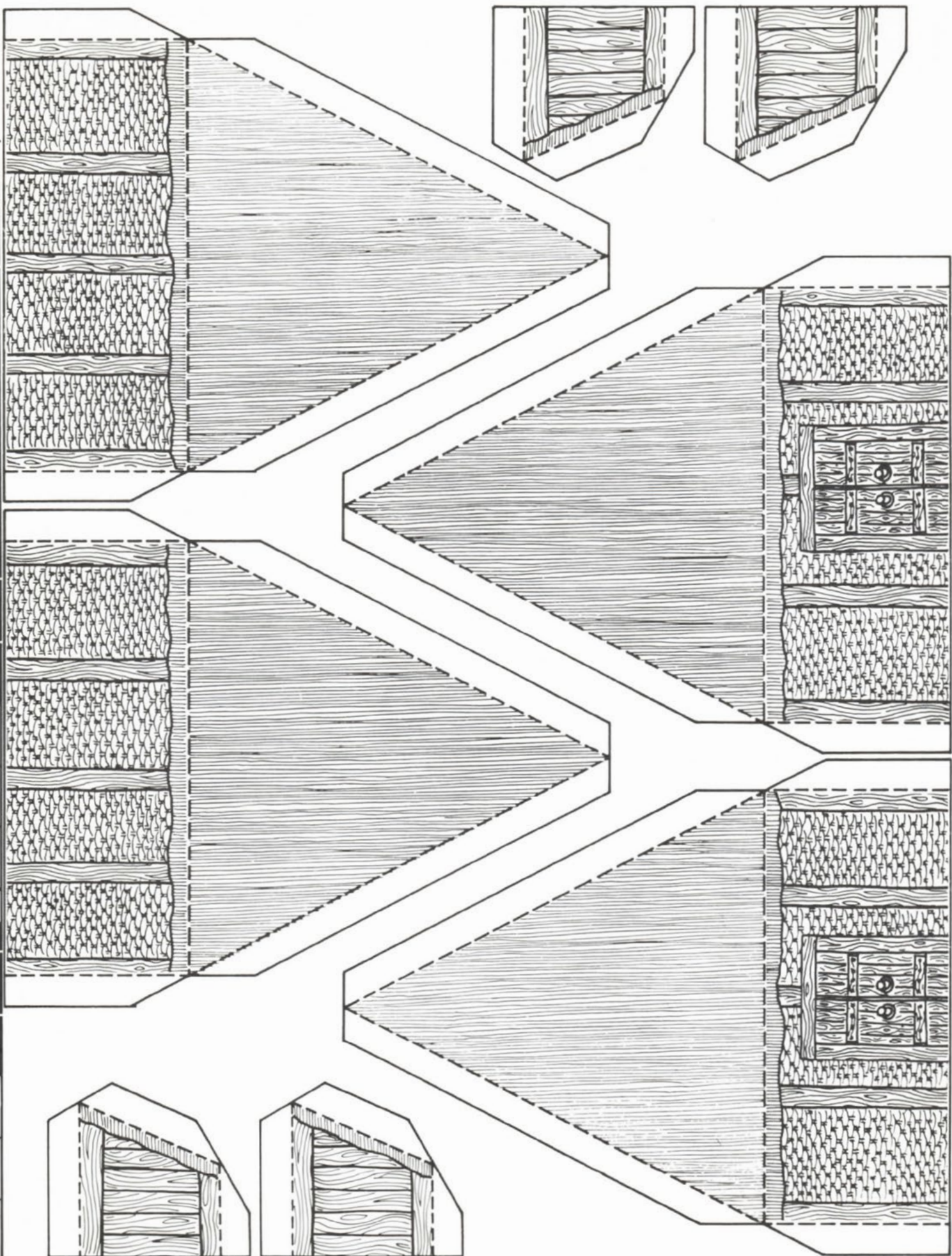

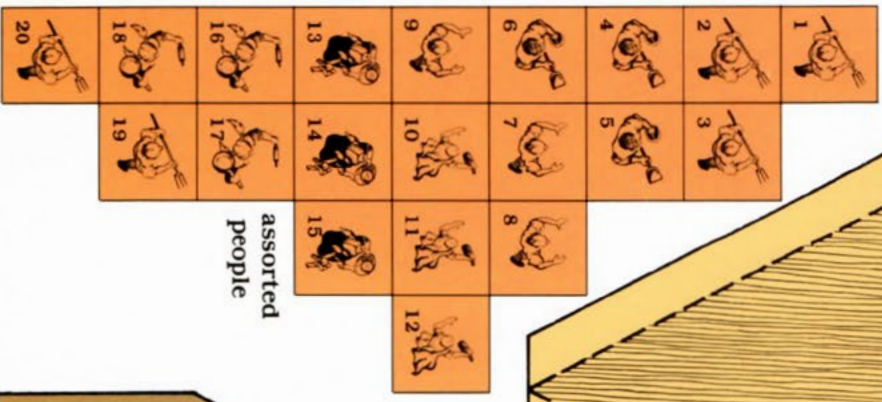

assorted people

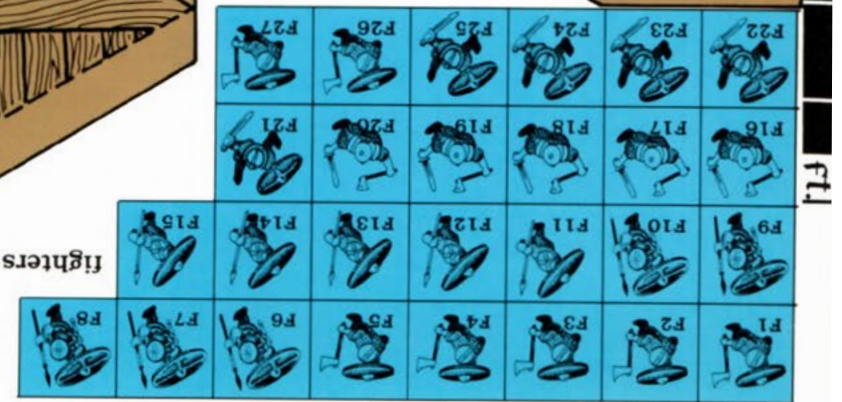
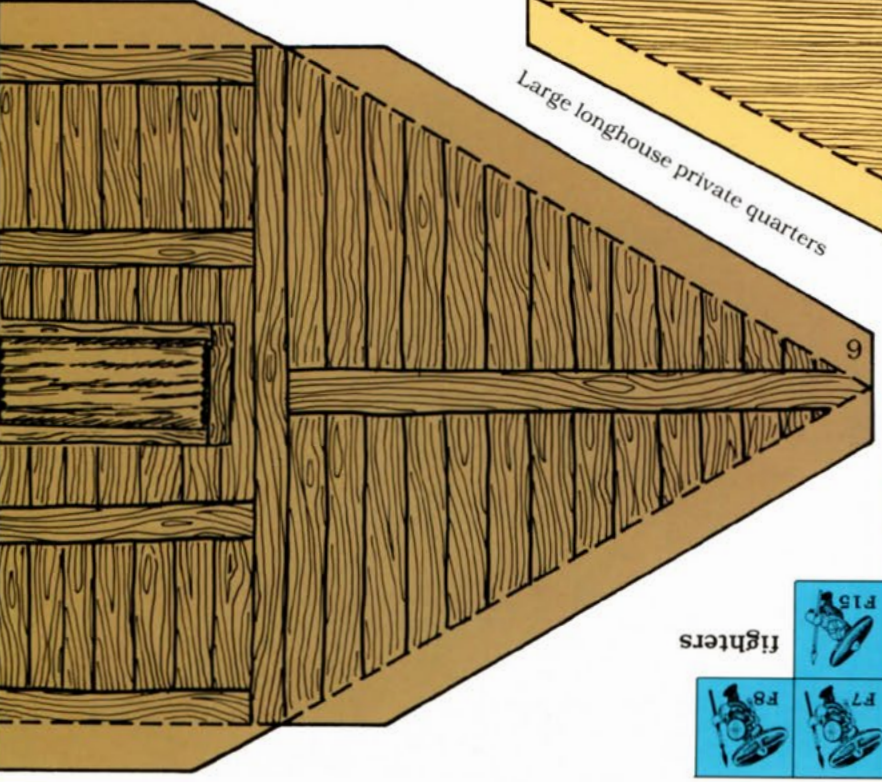
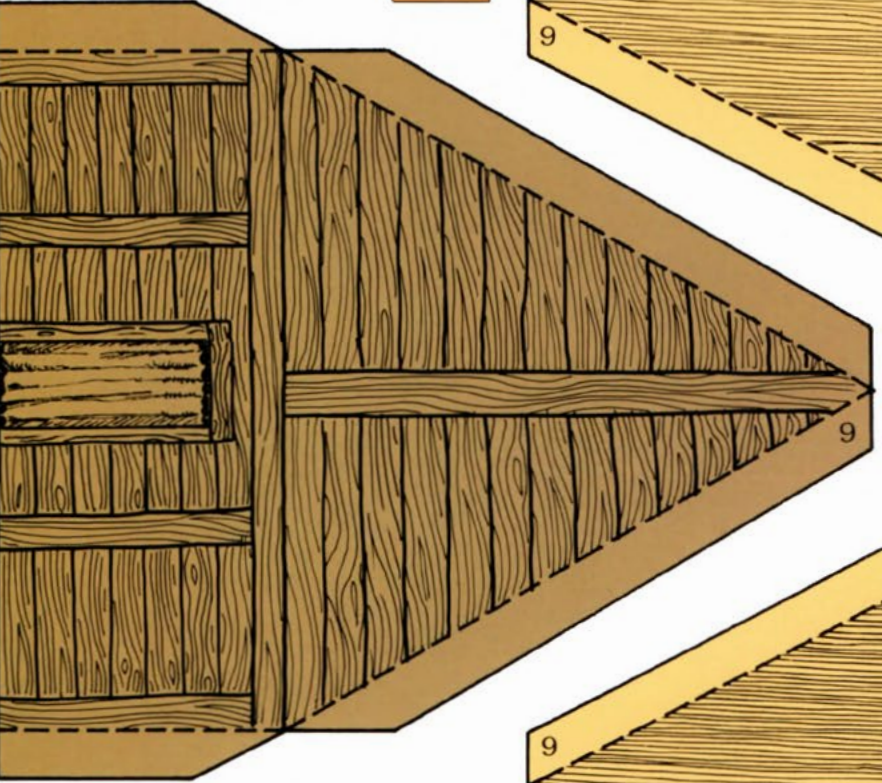
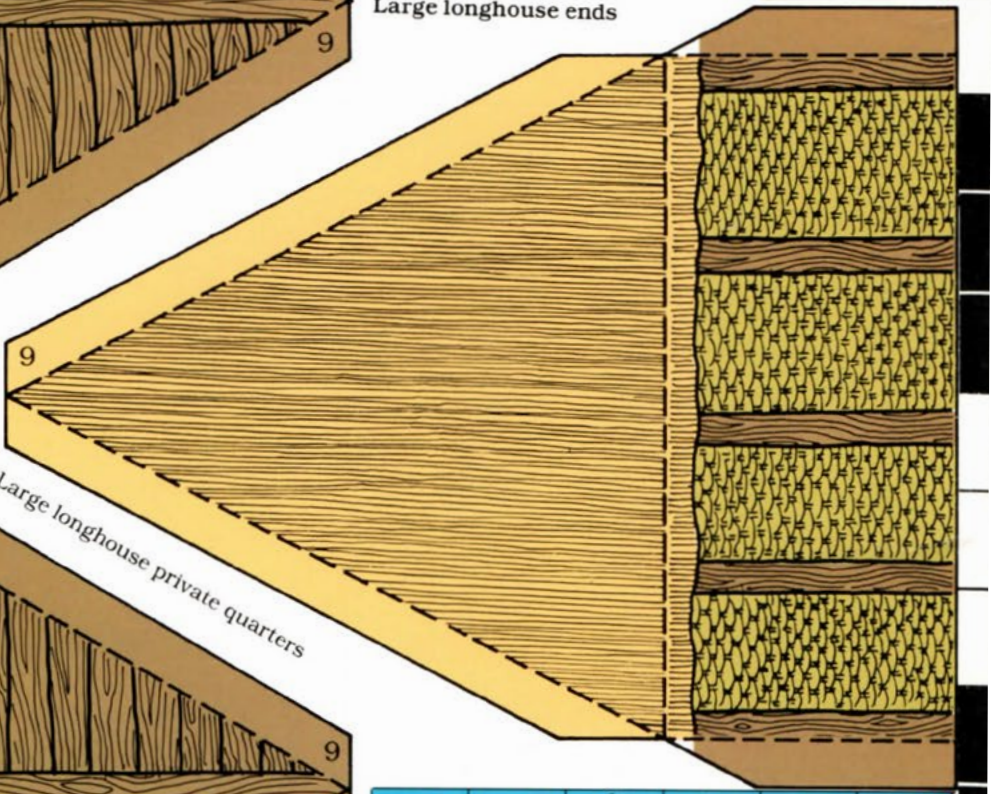
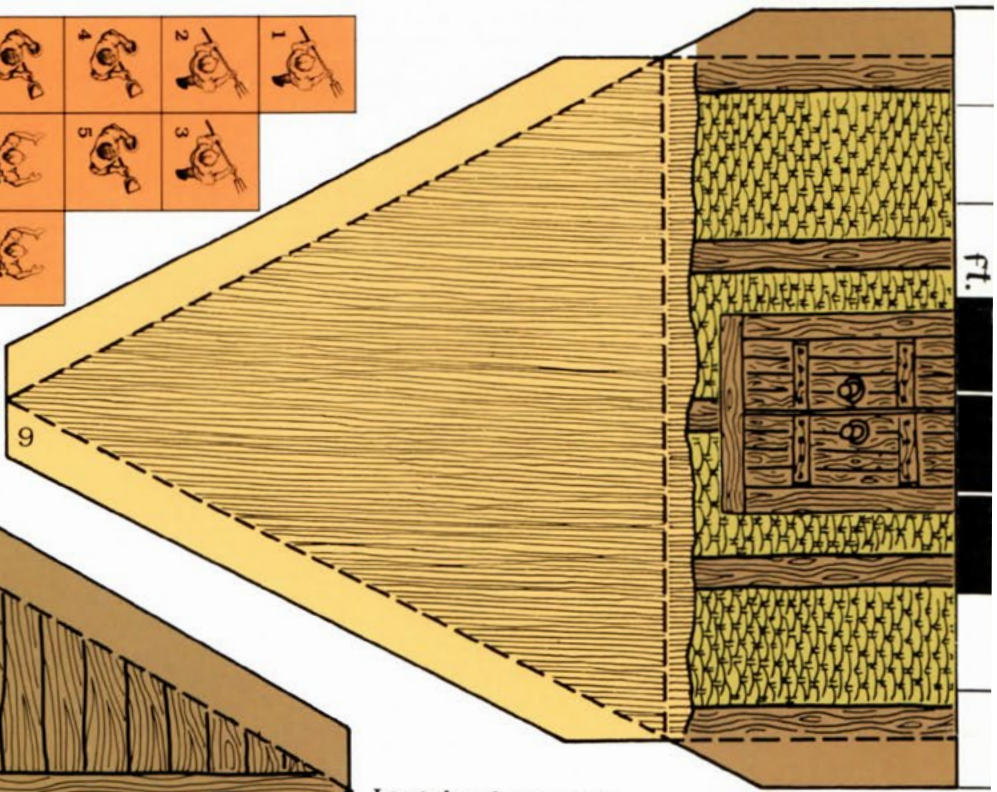

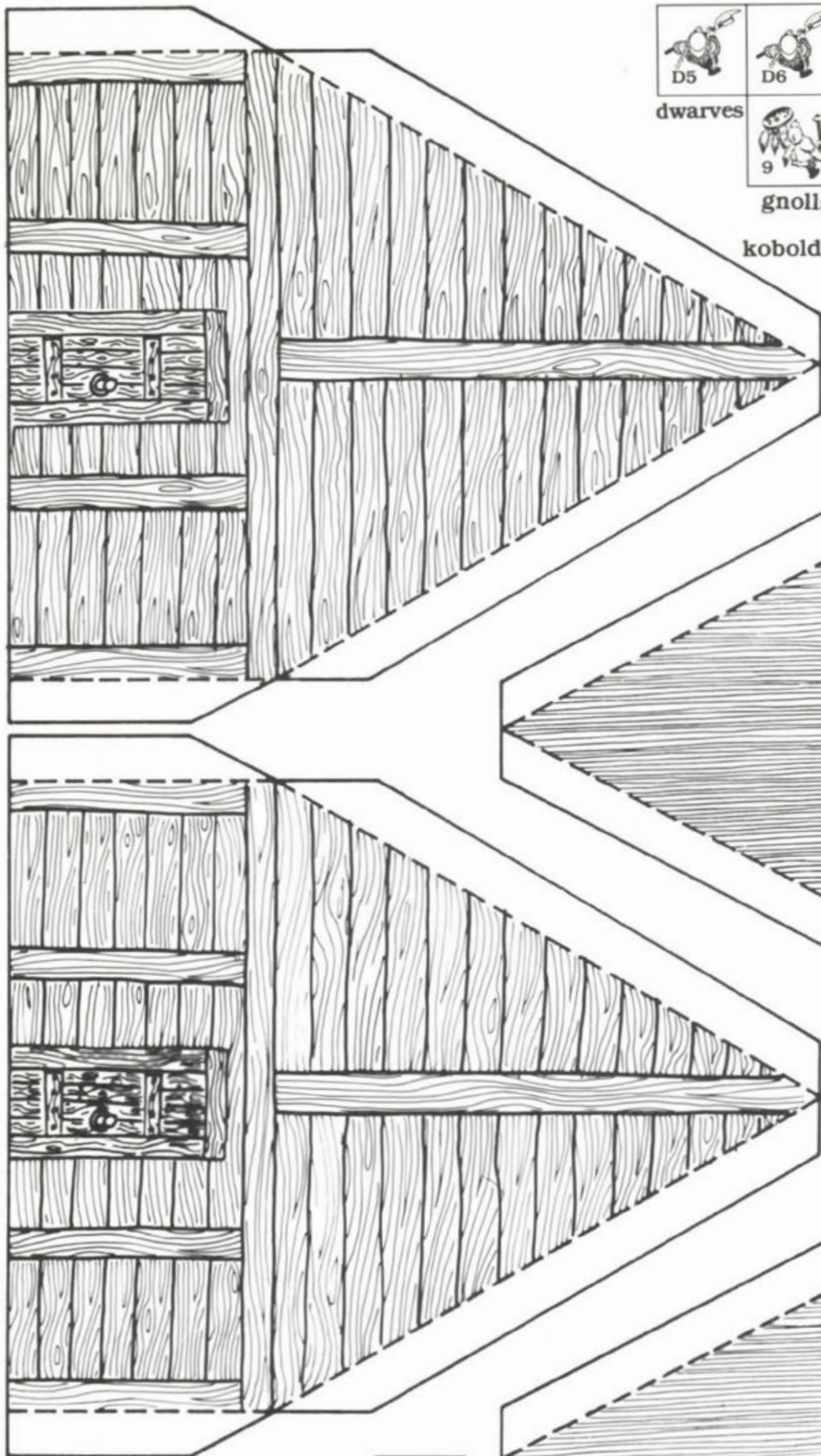

D5	D6	D7	D8	D9	D10	D11	D12
dwarves							
9	10	11	12	13	14	15	
gnolls							
1	2	3	4	5	6		
kobolds							
37	chief	brave	brave	brave	brave	16	

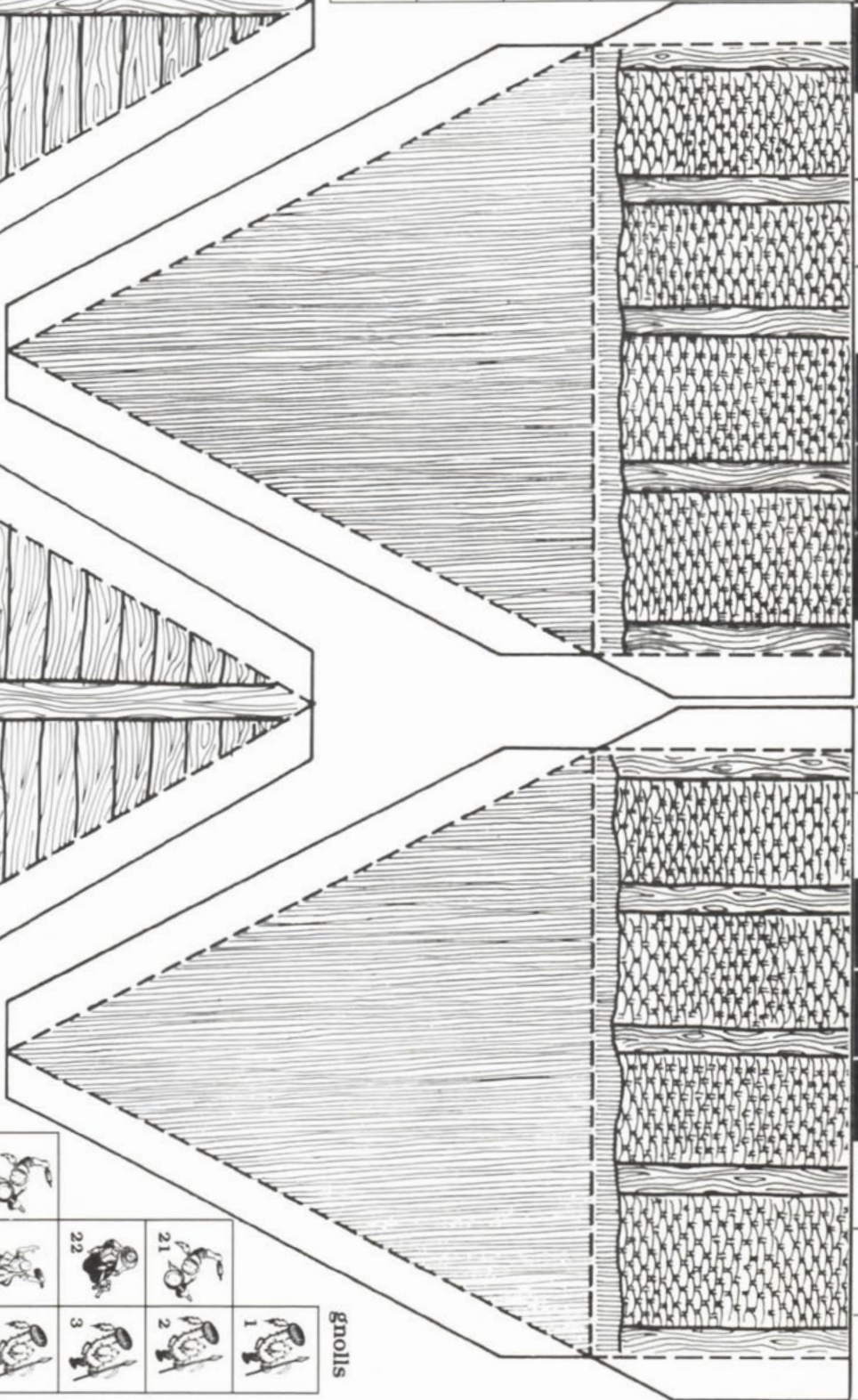

25									
28	26	23							
31	30	29	27	24	22	21			
32	8	7	6	5	4	3	2	1	gnolls

- |  |                  |  |                   |
|--|------------------|--|-------------------|
|  | Road             |  | Table             |
|  | Marshy Grassland |  | Sleeping Bench    |
|  | Muddy Compound   |  | Stool and Bench   |
|  | Earthen Rampart  |  | Pillars           |
|  | Timber Palisade  |  | High Seat         |
|  | Earthen Slope    |  | Screen            |
|  | Drainage Ditch   |  | Chests            |
|  | Bushes           |  | Guard Platform    |
|  | Boardwalk        |  | Stairs            |
|  | Fire             |  | Doors             |
|  | Fire Pit         |  | Stairs to Rampart |

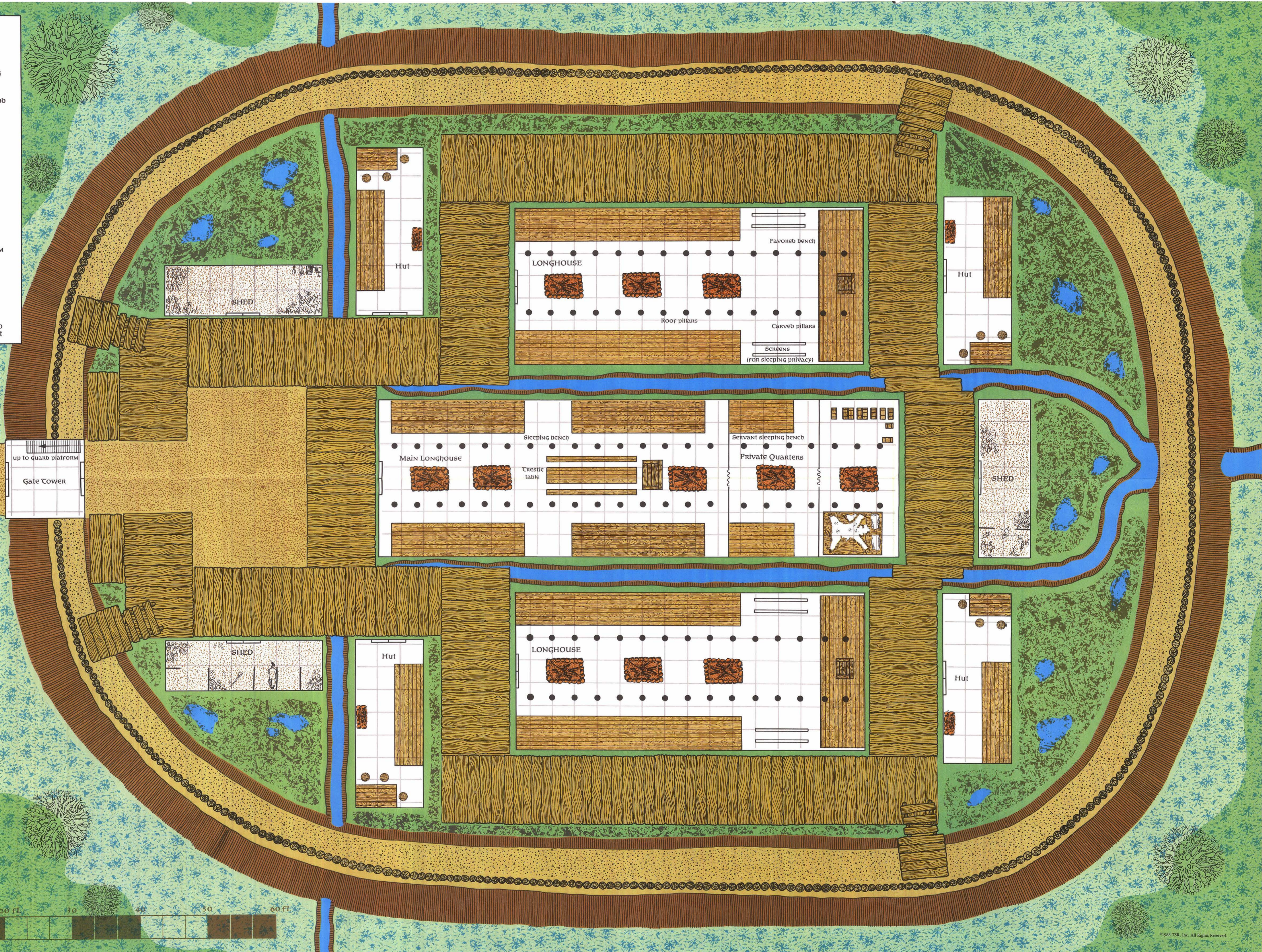

**NORRVIK, Capital of Vestland**  
Population: 9,000  
Scale: one inch = 300 feet

- Docks
- Quarantine and customs platform
- Sailor's Rest
- City quarantine stations
- Vestfjord Outfitters
- Svala's Cavern
- Clair's Hall
- Norrvik City Council Hall
- Market of the New Age
- Inn of the Twelve Princes
- Uppsal College
- Student housing
- Colab's Magical Supply and Used Scroll Store
- Crosta's Spices Tavern
- Mama Pia's Eatery
- King Harold's Castle

**Water Caltrops**  
When a ship strikes these harbor defenses, hull damage is received and the ship is stuck on the iron bars. The damage is 2-8 hull points on the first round with 2 additional points for flooding damage on each subsequent round until the ship is freed. A roll of 1-2 on 1d6 once per turn successfully frees the ship.

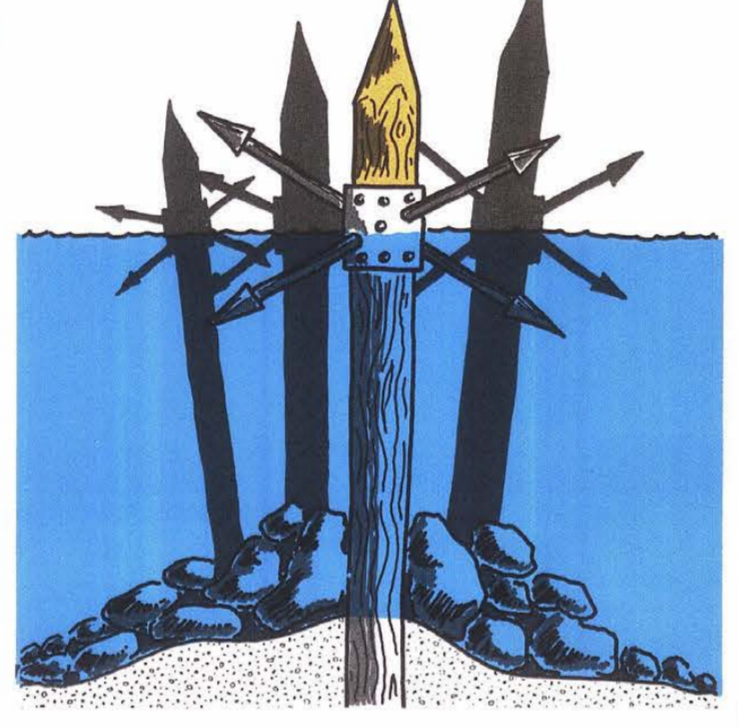

**KINGDOMS OF THE NORTHERN REACHES**

Regions shown include: HELDANN FREEHOLDS, ECHENGAR KHANACE, NORRVIK, VESCLAND, OSCLAND, SODERFJORD JARLDOMS, and EMIRATES OF VLARUAM. Rivers like the Vestfjord, Saltfjord, and Zeafjord are depicted. Islands such as Kunslo, Zea, and Storm are also marked.

**KNORR (Small sail ship)**  
**DRAKKAR (Longship)**

**ZEABURG, Capital of Ostland**  
Population: 8,000  
Scale: one inch = 300 feet

- The Royal Compound
- Great Hall
- Queen's Court
- King's Hall
- Queen's Hall
- Barracks of the Brothers of the King
- Temple of Odin
- Chapel's Quarters
- The Lower Fort
- Barracks of the Personal Guard
- Shrine of Midlir
- Granaries
- Houses of the Great Clans of Ostland
- Foreigners' Compound

**SODERFJORD, Capital of Soderfjord**  
Population: 7,000  
Scale: one inch = 300 feet

- Oak Tree Inn
- Goosefish Tavern
- Shippulders
- Potters
- Brewers
- Shoemakers
- Jewellers
- Weapons shops & Arms-and-armor shops
- Great Hall of the Soderfjord Clan
- Temple to Odin
- Temple to Thor
- Temple to Freyja
- Chieftains' Guild HQ & Temple of Loki



DUNGEONS & DRAGONS<sup>®</sup>  
**GAZETTEER**  
OFFICIAL GAME ACCESSORY

## The Northern Reaches

by Ken Rolston

Welcome to the Land of Vikings. Discover the berserk Jarls of Soderfjord, the Vikings of Vestland and the fearsome drakkars of Ostland. *The Northern Reaches* is a unique complement to your Gazetteer collection, providing detailed background on these three nations, their people, and many adventures, including:

- Separate Players' and DM's booklets—96 pages in all!
- Large, double-sided full-color map
- A complete 3-D Viking village
- 32 pages of exciting adventures in The Northern Reaches
- New Runic Magic for the D&D<sup>®</sup> Game
- Gates to the FORGOTTEN REALMS<sup>™</sup> Campaign Set

### Already Published in This Series:

*GAZ 1: The Grand Duchy of Karamaikos*

*GAZ 2: The Emirates of Ylaruam*

*GAZ 3: The Principalities of Glantri*

*GAZ 4: The Kingdom of Ierendi*

*GAZ 5: The Elves of Alfheim*

*GAZ 6: The Dwarves of Rockhome*

**NOW ADAPTABLE TO THE AD&D<sup>®</sup> GAME!  
NOMINATED FOR THE 1988 ORIGINS<sup>™</sup> AWARDS!  
ADVENTURES INCLUDED!**

©1988 TSR, Inc. All Rights Reserved. Printed in U.S.A.

TSR Inc.  
POB 756  
Lake Geneva,  
WI 53147 U.S.A

TSR UK LTD.  
The Mill, Rathmore Road  
Cambridge CB1 4AD  
UNITED KINGDOM