

ALL NEW MODULE FOR  
ANY FANTASY CAMPAIGN



# Dungeon Crawl Classics #4

## Bloody Jack's Gold

by Joe Crow

AN ADVENTURE FOR CHARACTER LEVELS 10-12



Remember the good old days, when adventures were underground, NPCs were there to be killed, and the finale of every dungeon was the dragon on the 20th level? Those days are back. Dungeon Crawl Classics adventures don't waste your time with long-winded speeches, weird campaign settings, or NPCs who aren't meant to be killed. Each adventure is 100% good, solid dungeon crawl, with the monsters you know, the traps you remember, and the secret doors you know are there somewhere.

In this all-new adventure, the characters acquire a treasure map tattooed on tanned human skin. It shows the location of famed pirate Bloody Jack's last haul, where hundreds of thousands of gold coins lie waiting to be taken. But exploring his long-abandoned island hideaway isn't as easy as it first seems. Bloody Jack didn't leave his treasure unguarded – and the best way to keep the undead legions well-stocked is to lure treasure-hunters to their death...

If you enjoy this adventure, look for the rest of the Dungeon Crawl Classics series!



[www.goodman-games.com](http://www.goodman-games.com)

# The Island

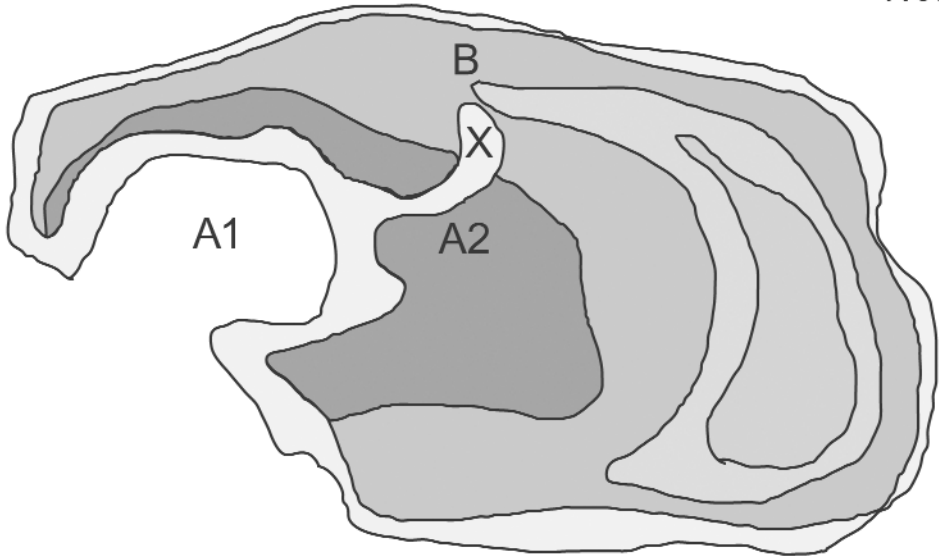

3 miles



# The Monastery

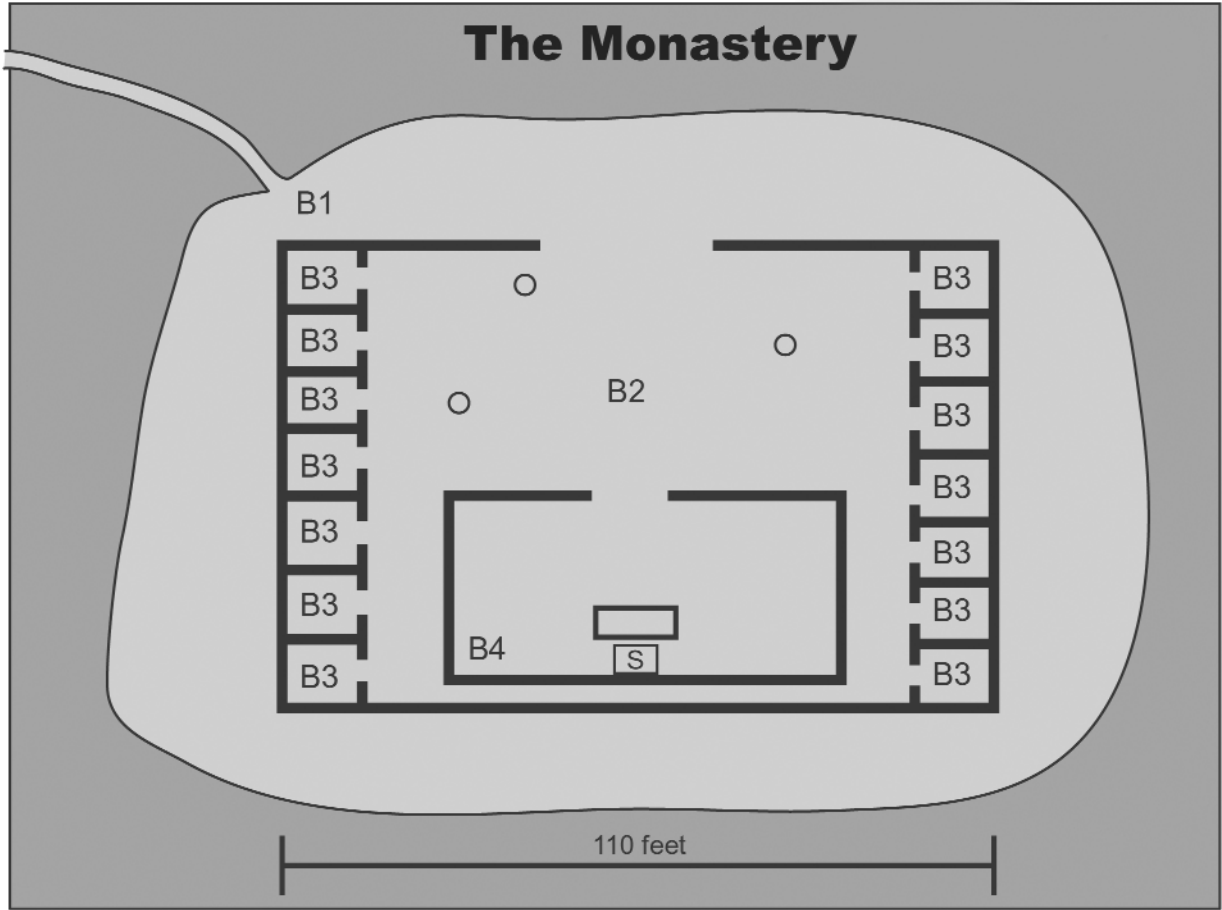

110 feet

# Area B5

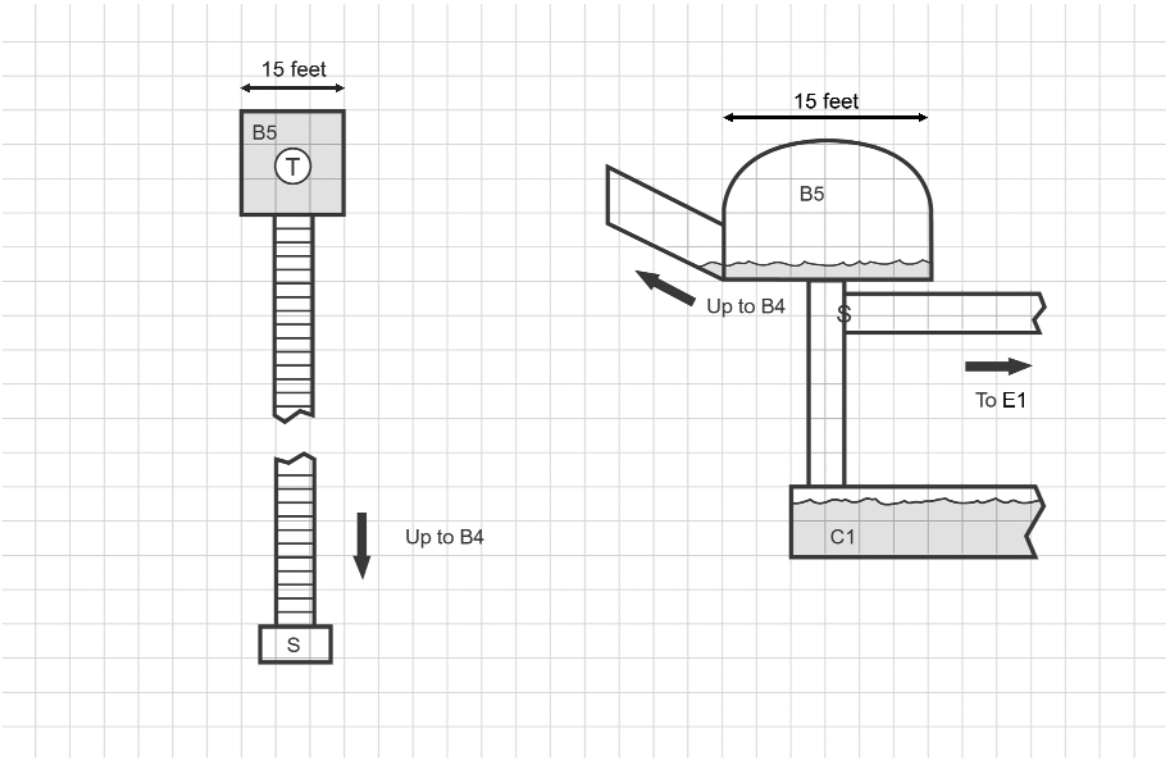

# The Sea Tunnels

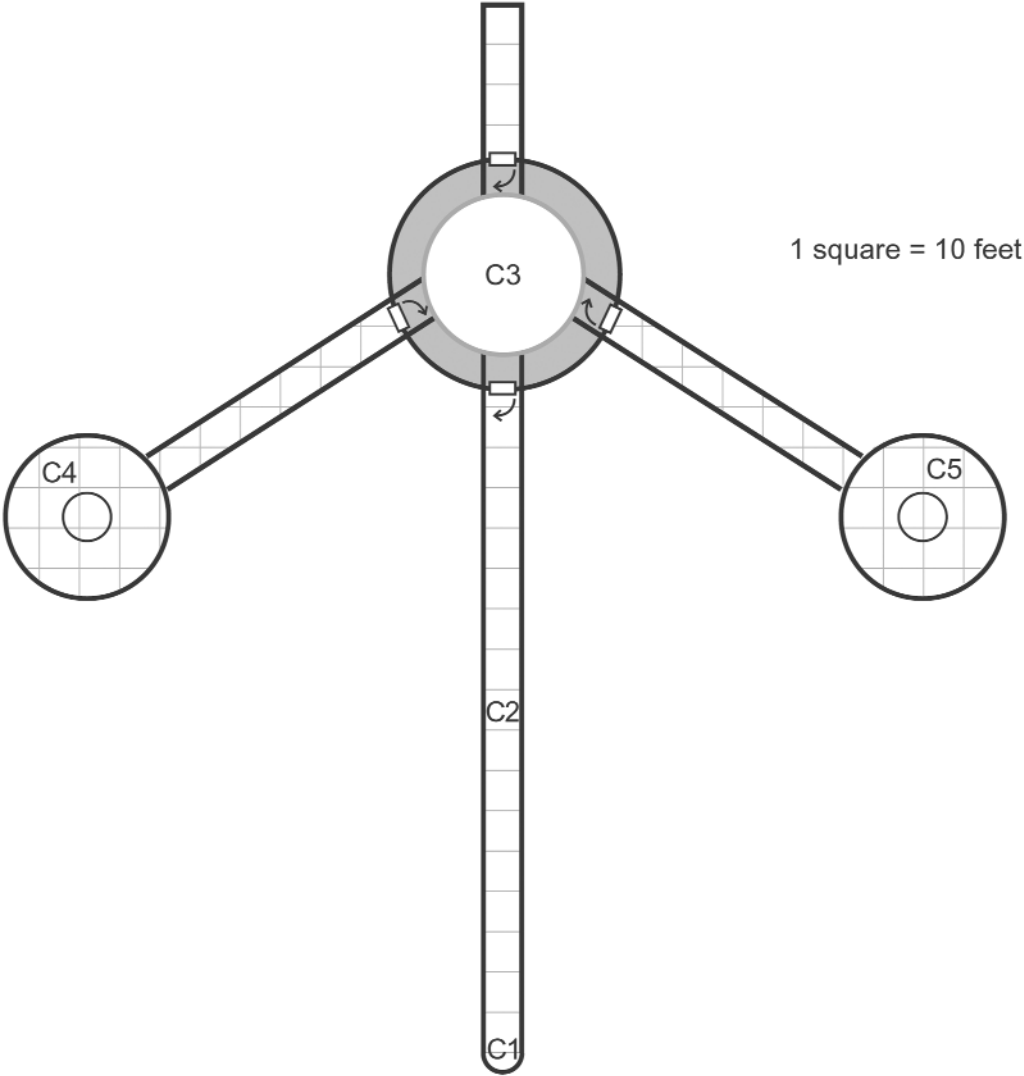

# The First Labyrinth

1 square = 10 feet

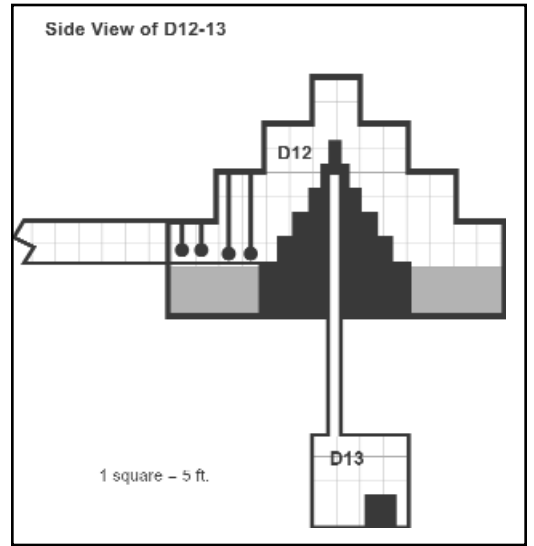
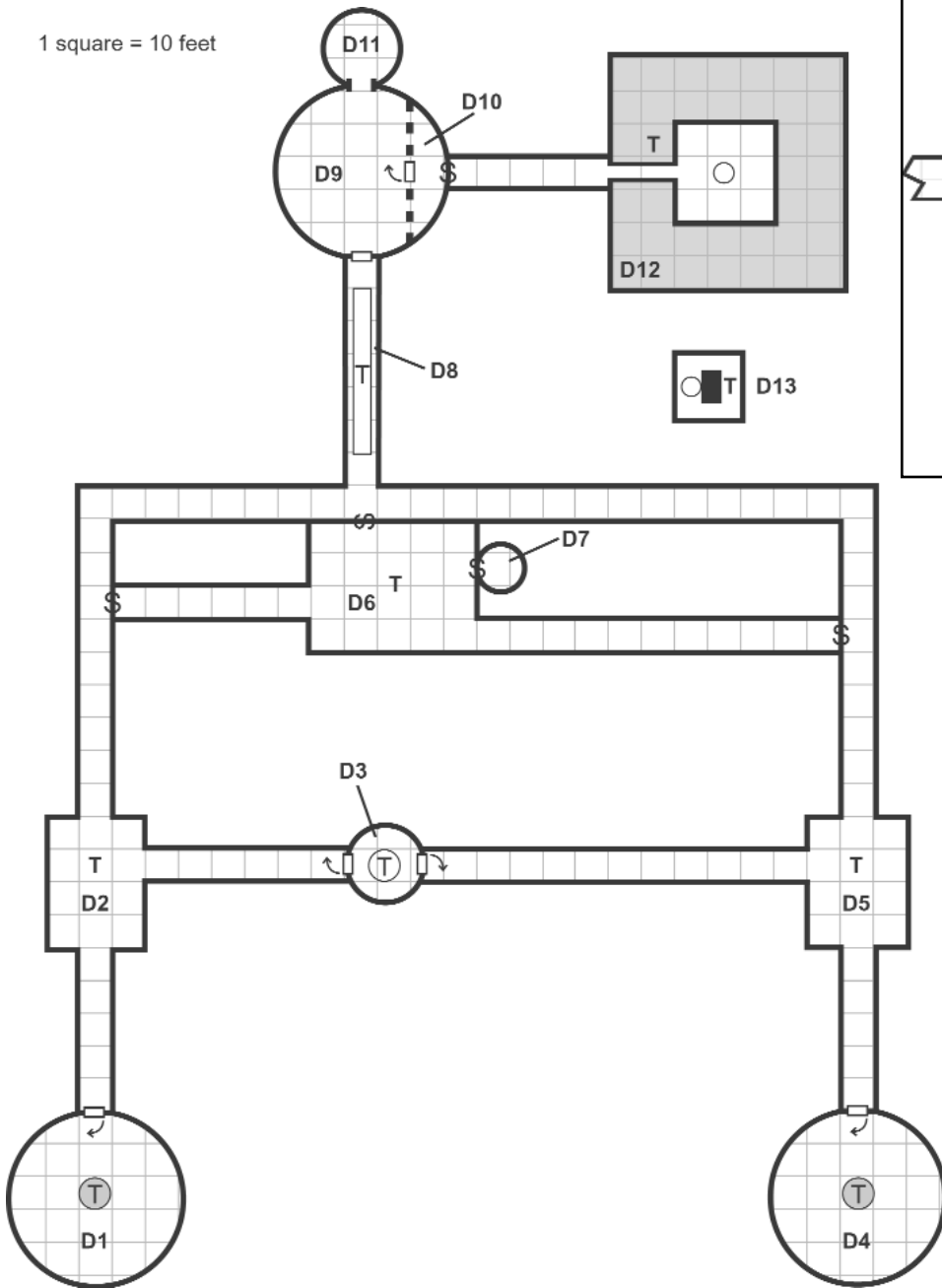

# The Second Labyrinth

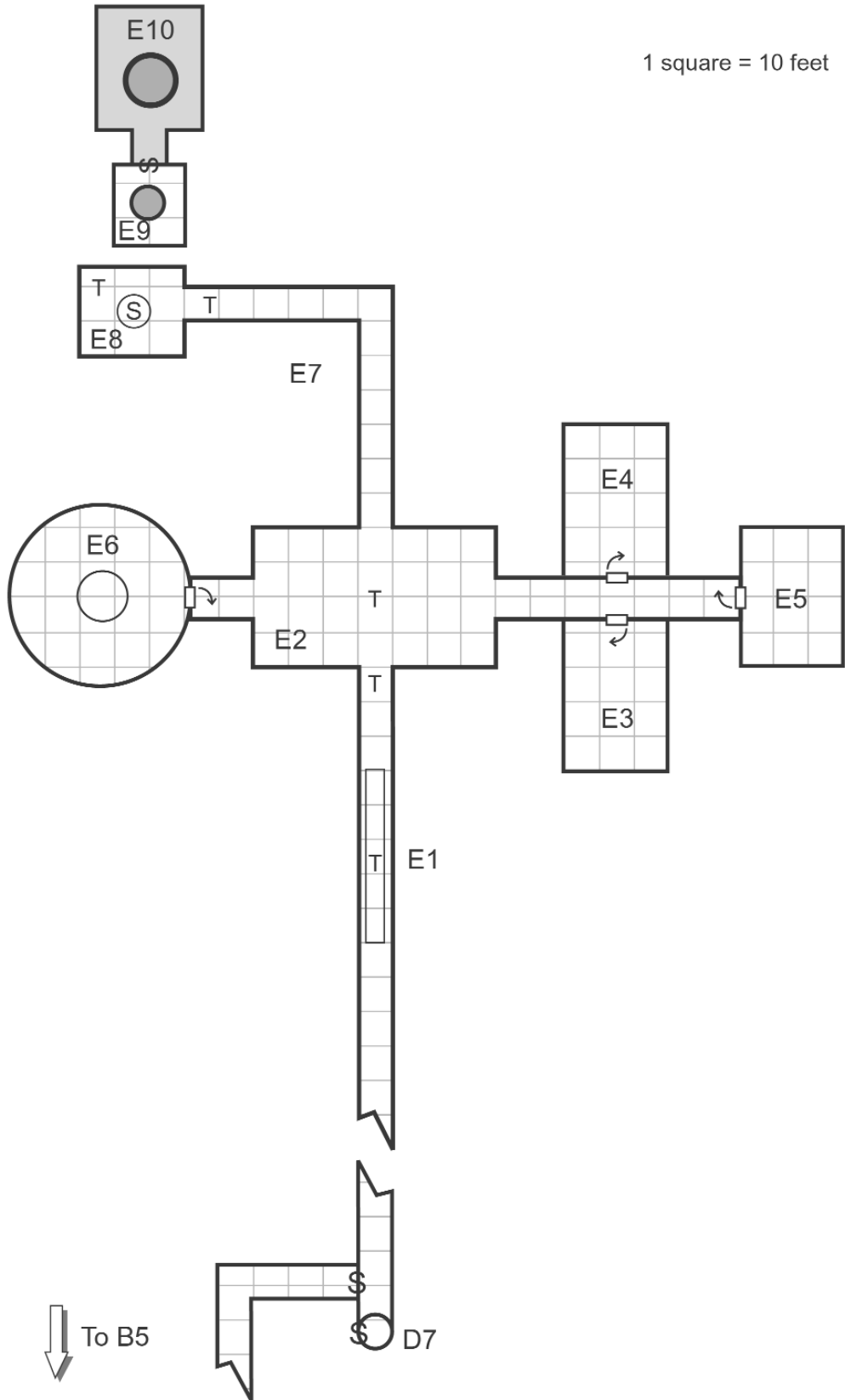

# Dungeon Crawl Classics #4 Bloody Jack's Gold

by Joe Crow

AN ADVENTURE FOR CHARACTER LEVELS 10-12

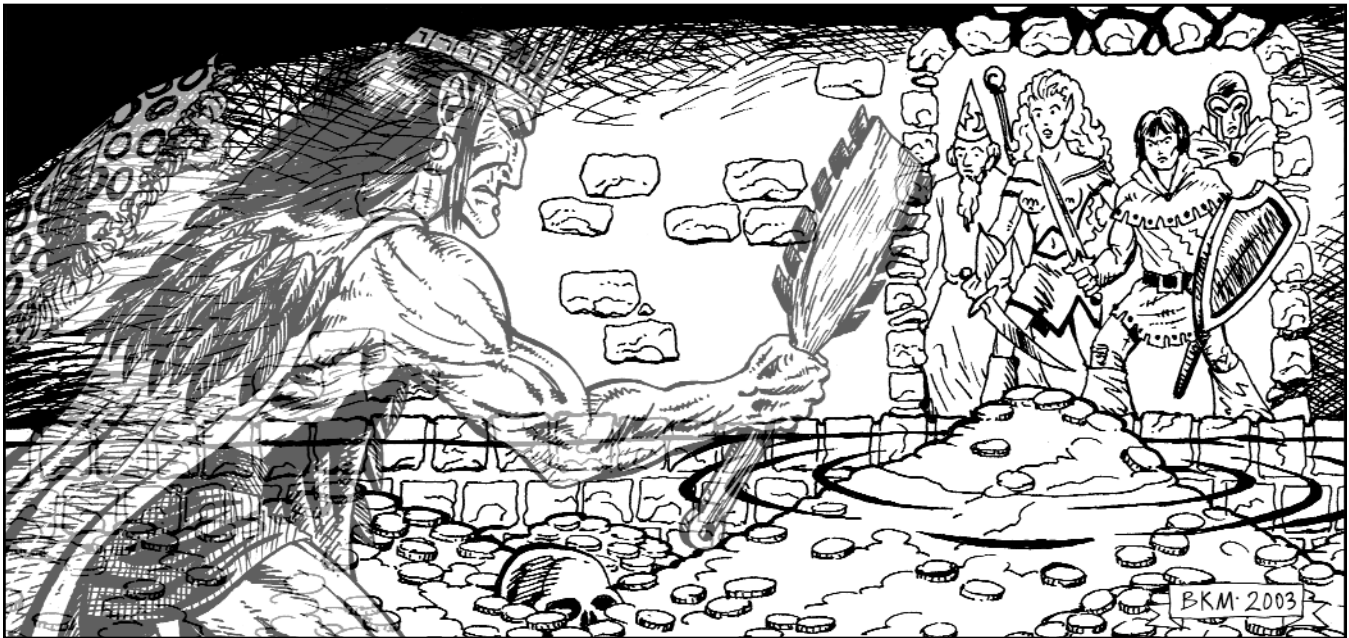

## Credits

**Writer:** Joe Crow  
**Front Cover Artist:** Erol Otus  
**Back Cover Artist:** Chuck Whelon  
**Interior Artists:** Brad McDevitt, Chuck Whelon  
**Cartographer:** Jeremy Simmons  
**Proofreader:** Ken Hart  
**Graphic Designer:** Joseph Goodman (with all due respect to the early-80's modules that inspired it)  
**Playtesters:** Poppy Arakelian, Jason Jope, and Mark Terry

## Table of Contents

Introduction	1
Game Master's Section	2
Background Story	4
Map Key	7
Level A: The Island	7
Level B: The Monastery	9
Level C: The Sea Tunnels	11
Level D: The First Labyrinth	14
Level E: The Second Labyrinth	23
Appendix 1: New Monsters	29
Maps	31



If you like this adventure, be sure to look for the rest of the Dungeon Crawl Classics series at your local game store.

Log on to our web site for freebies, news, special offers, and more.

# Introduction

Remember the good old days, when adventures were underground, NPCs were there to be killed, and the finale of every dungeon was the dragon on the 20th level? Those days are back. Dungeon Crawl Classics don't waste your time with long-winded speeches, weird campaign settings, or NPCs who aren't meant to be killed. Each adventure is 100% good, solid dungeon crawl, with the monsters you know, the traps you fear, and the secret doors you know are there somewhere.

Bloody Jack's Gold is designed to be a challenge for four to six players of 10th through 12th level, with the party's total character levels being at least 50. Though any of the basic character classes can be used, a group without a rogue or other trap-finding character is in for a world of hurting. A positive energy-aligned cleric would also be handy.

## Adventure Summary

A century ago, the pirate Bloody Jack Dascombe plundered an Imperial tribute fleet, the greatest hoard of his long and blood-soaked career. Though he was caught and executed shortly afterward, he died without revealing the treasure's location to a single soul. Old sailors whisper tales of the labyrinth Bloody Jack built to hide his booty in, and the horrible end that came to the unfortunate souls who built it. Many have gone in search of it, but none have returned.

The adventurers have acquired a map, tattooed on tanned human skin, that purports to describe the location of Bloody Jack's treasure. They have chartered a ship to take them to the nameless island described on the map. Though the map carries alleged instructions for threading the maze Jack built to protect his loot, these directions say nothing about the creatures now inhabiting the labyrinth. Nor do they tell the tale of Coyopultec, Jack's lieutenant, whom he betrayed and murdered to conceal the secrets of the maze. Coyopultec's ghost has returned from the grave to haunt the labyrinth. He whiles away the long years by capturing intruders and bartering their souls to the forces of Hell in exchange for aid in preparing for Bloody Jack's return.

The adventurers' ship has dropped anchor just inside the shallow lagoon on the coast of an island matching the location on the map. The map also shows the path to the entrance of the labyrinth, a path that seems to start where the jungle meets the beach of the lagoon.

## Game Master's Section

### Encounter Table

Here is a quick reference table so you can see all of the encounters at a glance. Loc – the location number keyed to the map for the encounter. Pg – the module page number that the encounter can be found on. Type – this indicates if it is a trap (T), puzzle (P), or combat (C) encounter. Encounter – the key monsters, traps, or NPCs in the encounter. Italicized names are classed NPCs. EL – the encounter level.

Loc	Pg	Type	Encounter	EL
A1	7	C	Fiendish Shark	5
A2	8	C	Fiendish Dire Boar	7
B4	9	C	4 Shadows	8
B5	10	C/T	8 Fiendish Stirges Camouflaged Pit Trap	6
C1	11	C	4 Fiendish Barracudas	7
C2	12	C	5 Fiendish Moray Eels	8
C3	12	C/T	Fiendish Chuul Pinning Spears Trap	9
C4	13	C/T	Fiendish Giant Octopus Tunnel Scythe Trap	10
C5	14	C/T	Fiendish Giant Moray Eel Tunnel Scythe Trap	9
D1	15	C	Fiendish Monstrous Spider Fiendish Spider Swarm	8
D2	16	T/C	<i>Desecrate</i> Trap Wight 6 Zombies 6 Skeletons	8
D3	16	C/T	Fiendish Monstrous Spider Centipede Pit Trap Fiendish Centipede Swarm	7
D4	18	C	4 Phantom Fungi	8
D5	18	T/C	<i>Desecrate</i> Trap Wight 6 Zombies 6 Skeletons	8
D6	18	T/C	<i>Desecrate</i> Trap Elite Wight 2 Wights 10 Zombies 10 Skeletons	9
D8	19	T	Whirling Axes Trap	7
D9/D11	20	C	11 Fiendish Baboons 2 Half-Fiend Baboons	9
D10	20	C	Half-Fiend Dire Ape	9
D12	21	T/C	Stone Hammers Trap 30 Fiendish Barracudas 20 Skeletons 4 Elite Wights 3 Pirate Spectres	12
D13	22	T/C	Poisoned Needle Trap Water-Filled Room Trap Gibbering Moulder	11
E1	23	T	Crushing Wall Trap	8
E2	23	T/C	<i>Desecrate</i> Trap <i>Darkness</i> Trap 3 Elite Wights 5 Wights 12 Skeletons 12 Zombies	12

Loc	Pg	Type	Encounter	EL
E3	24	C	4 Skeletons	3
E4	24	C	3 Zombies Brown Mold	3
E5	25	C	3 Zombies Wight	3
E6	25	C	3 Chain Devils	9
E7	26	T	Rolling Boulder Trap	8
E8	26	T	Retracting Ladder Trap	8
E10	26	C	<i>Coyopultec</i> <i>Grishnaz</i> and viper familiar 2 Bone Devils Huge Water Elemental 4 Skeletons	14

## Scaling Information

Bloody Jack's Gold is challenging even for characters within the recommended level range of 10th-12th. If they are not cautious and don't use good tactics, it will prove to be a very difficult adventure. Or, to put it another way, our playtests had "lethality issues."

The adventure can be easily modified for parties of different sizes or level – or simply to give the players an easier time – as follows:

**Weaker parties (3 or fewer characters, or characters below 10th level):** Remove the fiendish template from some or all of the monsters, depending on the characters' power level. Reduce the Search and Disable Device DCs for the traps by 2-6 points. Limit the ability of Coyopultec to reanimate undead that have been destroyed (perhaps he can't leave his final resting place). Halve the number of zombies and skeletons in the more complex encounters: areas D5, D6, D12, E2, and E10. Possibly reduce Coyopultec's cleric level in the final encounter.

**Stronger parties (7 or more characters, or characters above 12th level):** Increase the number of zombies and skeletons in areas D2, D5, D6, D12, E2, and E10 by at least 25%, possibly more. Double the number of fiendish opponents in areas A1, A2, B5, C1, C2, and D3. Increase the Search and Disable Device DCs for the traps by 2-4 points. Make Coyopultec a 12th or 14th level cleric.

## Getting the Players Involved

The following hooks can be used to get the players involved with the search:

- A party member inherits a chest of keepsakes from an old seafaring relation (or finds it in a treasure horde). Hidden in a false bottom is the map, with some scribbled notes explaining what it is.
- Though the Imperial Navy has grown tired of losing ships in the hunt for the gold, an enterprising young captain has found what he believes to be a genuine map. He has hired the adventurers to retrieve the loot,

in exchange for a handsome finder's fee and his patronage for further ventures in the Empire.

- The adventurers are on an unrelated sea voyage, and their ship has stopped at the island to acquire water and provisions. Oh, look, there's a mysterious pathway into the jungle! Let's go exploring! Suckers...

## Player Death

Coyopultec has left standing orders with the undead troops to take captives whenever possible. As a result, the wights are sparing with their energy drain ability, only draining characters to within a few levels of death and then pummeling them into unconsciousness. They also make a point of calling off their troops once characters are into negative points, and making clumsy efforts to stabilize them. They don't always succeed (oddly enough, the undead aren't very good at keeping people alive), but they do try.

Unconscious characters are bound securely, stripped of their equipment, and taken to the Barracks in the Labyrinth and then to the Muster Hall on the second level. If they've made a contract with Grishnaz, then they are left in the Forge, under the guard of the chain devils. When he has a chance, Grishnaz spends some time with them, sounding them out to see if they'll help him convert their comrades.

Those who haven't made a contract are offered one. If they refuse, then they're stripped and left in the Bone Room, under the guard of the skeletons. Later, Coyopultec will use them as either trade goods for his infernal partners or as sacrifices to his god. All equipment is stored in the Armory.

## Treasure

There's almost nothing for treasure in the labyrinth until the very end. None of the creatures encountered have anything besides minimal (and rusty) equipment, with the exception of Grishnaz the imp. Of course, the loot at the end should make up for it, assuming anybody survives to get it. The amount may seem a bit over-sized, but it's *supposed* to be impressive.

GMs who are nervous about giving their players boat-loads of cash (literally) are reminded that the players have to:

- Get the loot back through the maze and off the island (we're talking about nearly 15 cubic feet of loose metal coins, weighing more than 5 tons)
- Get the loot back to the mainland without the ship's crew cutting their throats for it
- Sneak the loot past Imperial tax-men and naval officers looking to get back all that lost revenue
- Probably cope with the ghost of Coyopultec (unless they've been *very* clever about putting him to rest)
- And maybe even deal with Bloody Jack, now that the treasure is off the island.



# Background Story

## History of the Island

The island doesn't have much history, or a name. It was uninhabited for millennia until a few centuries back when an order of monks settled here to train in isolation. Unfortunately, they were destroyed a few years later by a wandering tribe of sahuagin. There are no records of what they called the island. Neither Jack nor Coyopultec bothered to name the island, and their captives simply called it "hell." The Imperial Navy captains who periodically rediscover the island usually name it after themselves, but all their records are at the bottom of the ocean, along with their ships. Such is life.

## The Tale of Bloody Jack Dascombe's Last Raid

Jack Dascombe was a legend in his day, a bloodthirsty pirate who raided, pillaged, and burned countless ships and coastal cities before finally meeting his death at the end of a rope. He was rumored to have once been an Imperial naval officer who was unjustly court-martialed, and escaped to wreak his revenge on those who wronged him. If so, he seems to have spread his revenge with a very broad brush. Aside from the occasional attempt to ransom a particularly wealthy victim, he is alleged to have killed every prisoner he ever captured and burned every ship he ever took. The songs and stories of his time portray him as a murderous fiend in human form, who delighted in butchery and slaughter for its own sake and led a crew nearly as bloodthirsty as himself.

By the end of his 15 year career, he led a fleet of nearly 50 pirate ships. This sizeable following allowed Bloody Jack to make his legendary Last Raid, plundering an Imperial tribute fleet. Imperial tribute fleets are renowned for their impregnability, as can be expected for a fleet that transports hundreds of thousands of gold and silver coins from the Empire's far-flung colonies and satrapies to the Imperial homeland's bottomless coffers. The Empire takes its tribute very seriously, and no one before or since has replicated Jack's feat. The songs about Jack's Last Raid claim that with a combination of infernal sorcery, matchless seamanship, and savage battlecraft, Jack managed to sneak an entire crew aboard one of the armored treasure galleons and slew every man aboard before signaling for his fleet to attack the escorting Imperial warships. He then rammed the huge galleon through the embattled escort and sailed off, abandoning his own fleet to cover his escape.

Though Jack escaped with the loot, most of his fleet was destroyed by the vengeful Imperial warships. Jack hid the treasure and tried to return to buccaneering, but the tales of his treachery had spread far and wide. He found it difficult to recruit new followers. A few years later, the Empire caught up with him. The captain who managed to take him was afraid that Jack would escape, as he so often had before. So he quickly scuttled Dascombe's beloved flagship before his

eyes, before hanging Jack from the yardarm without even a show trial, only a brief (and brutal) interrogation concerning the whereabouts of the treasure. For his reward, the captain was granted a noble title and lands and, shortly thereafter, a trial for treason and a quick beheading.

Legend has it that Jack's body was buried at sea, and that soon after he rose from his watery grave. Sailors tell gruesome tales of how Bloody Jack's revenant now roams the sea searching for his treasure in the shell of his sunken ship, the Red Skull, and sinking every Imperial ship that crosses his path. Most authorities, especially Imperial ones, say these tales are foolish superstition, and that Jack is just another dead pirate. Still, one of the best ways to start a bar fight with Imperial sailors is to sing one of the many songs about Bloody Jack's Last Raid, and the Empire periodically funds searches for the missing treasure, more than a century later. None have succeeded and most never return at all.

## Empire? What Empire?

In this adventure, there are lots of vague references to an "Empire." It's meant to suggest a combination of the British and Spanish seafaring empires of the 17th century, widespread, slightly corrupt, militarily powerful, and ambitious. It's a source for all sorts of adventures. There are also brief mentions of Aztecish city-states far to the south, called the Xulmec. But what if your campaign world doesn't have an Empire like that, or Aztecish city-states?

Well, why not? What are you, a snob? Seafaring empires and Aztecs rock!

More seriously (and less insultingly), references to the Empire can be replaced by any large political entity in your world. All you need is something with a strong naval reputation, easily recognizable armor and equipment, and scads of cash for Jack to have stolen. It doesn't even have to be a political group. A major merchant guild or even a pirate brotherhood could be substituted. As for the Xulmec, any far-off culture with strange wargods and pyramids can be substituted. That's why they're "far-off."

Or you could just insert a seafaring empire into your campaign world, and hope nobody notices. It's not like players pay any attention to your carefully crafted backstory anyway, the lousy ingrates.

## Hiding the Booty

Though few songs speak of him, Jack had a longtime com-patriot, a death priest of Coatlimict from the Xulmec city-states to the south. Exiled for "over-enthusiastic performance of his duties," Coyopultec found a sympathetic commander in Bloody Jack. They shared a taste for bloodshed and terror, and Coyopultec was the only one of Jack's subordinates who knew of Jack's plan for the treasure.

Jack had found the island many years ago, untouched except for an abandoned monastery. He and Coyopultec

sailed the galleon there and began to prepare a safe hiding place. After kidnapping a small dwarven engineering clan and raiding a few Imperial slave ships, they were ready.

After some “persuasion,” the dwarves agreed to supervise the construction of an elaborate maze, and the slaves set to work. The construction took almost an entire year, used up a sizeable fraction of the loot, and claimed the lives of nearly everyone involved, including, to his surprise, Coyopultec. He’d helped to kill the others and animate their corpses to serve as an eternal guard to staff the labyrinth, but in the end it seemed that Jack didn’t feel like sharing. His last act before leaving the island was to stab Coyopultec in the back and leave his body atop the pile of gold and silver coins hidden in the labyrinth, as a morbid trophy.

## Coyopultec’s Revenge

The betrayal, not surprisingly, angered Coyopultec’s spirit greatly. Enough so that he declined to join his patron god in his bloodstained paradise and chose to haunt the labyrinth, waiting for a chance at revenge. As Coatlimict is a fan of carnage, the god graciously allowed his priest to remain in the world (sort of) and even introduced the vengeful phantom to some beings that might assist him.

The Lords of Hell were happy to help, and Coyopultec has acquired many fiendish allies to help him prepare for Jack’s return. In exchange for their assistance, Coyopultec captures all who enter the labyrinth (and survive) and offers their souls to his infernal allies. Chief among his assistants is an imp named Grishnaz, who has made a profitable sideline in tempting intruders to sell him their souls in exchange for scraps of information about how to survive the maze. He then trades them to other fiends who are interested in acquiring cut-rate mortal pawns. His primary duties, however, are to oversee the day-to-day functioning of the dungeon, dealing with discipline problems among the various creatures, transmitting orders from Coyopultec to the wights, and supervising any alterations that the chain devils feel like making in the traps.

Coyopultec has restaffed the maze with all sorts of fiendish

creatures and undead under his control, replacing all the former residents. He even has his devilish allies occasionally attack ships that pass nearby to restock on corpses for the maze. He’s also arranged for constant improvements and alterations to the traps. Jack would barely recognize the labyrinth now.

That is, of course, if Jack were able to return. He is, after all, quite dead. While Coyopultec is aware of this, he feels that since his own death didn’t really take, there’s a good chance that Jack’s still around in some form or other, and he intends to be ready for him. The Lords of Hell don’t really care one way or the other, as long as they keep getting souls, and Coyopultec’s patron just likes watching people die horribly.

Of course, nobody off the island has any idea about this. While there are rumors about the existence of the labyrinth, the few survivors are far too in hock to Hell to say anything. Most of them are too busy trying to get their souls back to even think about blabbing.

## The Map

So, where’d the map come from? According to legend, Bloody Jack had a map tattooed on the back of one of the slaves, then skinned him, had it tanned, and hid it “somewhere.” Sages generally dismiss this part of the tale; after all, why would Jack need a map to find his own treasure?

They are entirely correct. The last thing Dascombe wanted was for someone else to be able to find his treasure. The map is a fake, created by Grishnaz to ensure a steady supply of dungeon fodder. It was one of the first things he thought of when he came to work for Coyopultec, and he has another one planted on the mainland every year or so by other agents of the Infernal Powers.

The fake map is tattooed in red on human skin. It’s about 14 inches square, with ragged edges, and appears to have been taken from someone’s back. It depicts the island, shows the location of the monastery, and has coded directions written along one side. A Decipher Script check (DC 20) is enough to break the code (Grishnaz didn’t want it to be *too*

## Coatlimict

Coatlimict (*ko-ah-li-mikt*), the Xulmec god of war and undeath, is neutral evil. He is called The Serpent-Haired, Skull-Father, Prince of the Summer Harvest, and Reaper of Men. He delights in bloodshed, butchery, and raising fallen warriors to do battle once more. Coatlimict’s worshippers are mostly fighters, necromancers, and blackguards. Death, Evil, and War are his domains. He is usually depicted as a giant, over-muscled humanoid whose head is a skull, with living serpents for hair, who bears his favored weapon, a two-handed macuahuitl. His symbol is a stylized skull with serpents radiating from it.

## Macuahuitl

The macuahuitl (*ma-koo-ah-hwee-tul*) is a flat wooden club with extremely sharp blades of obsidian or flint set into the edges, capable of shearing through both flesh and bone. Macuahuitls come in both one- and two-handed varieties. They are martial weapons for natives of the Xulmec city-states, but are exotic for everyone else.

Name	Cost	Dam/Crit	Wt.	Type
Macuahuitl, one handed	20 gp	1d8/x3	7 lb.	Slashing
Macuahuitl, two handed	50 gp	2d6/x3	13 lb.	Slashing

hard) and reveals both navigational directions to the island and vague directions on how to thread the maze. While the navigational directions are correct, the maze directions are utterly false. Feel free to make up something that'll lead the party directly into one of the tougher encounters.

## Let's Make A Deal

Grishnaz really enjoys his work in the maze. It's a position of great responsibility for an imp, even in the mortal world, and he's made something of a name for himself as a tempter among other minor devils. Another century of this, and he'll be in line for a promotion.

As soon as a party enters the labyrinth, Grishnaz begins to shadow them *invisibly*. He spends as much time as possible with them, getting to know the party members by eavesdropping on them so he can target the most corruptible ones. Whenever one of the party members is in grave danger and somewhat isolated from the group, he'll use *message* to offer her a way out. All the adventurer has to do is agree to perform an unspecified service for him at some point in the future, and sign a contract to that effect. If the character agrees, Grishnaz uses his extensive knowledge of the labyrinth to guide her through whatever danger she's in, or uses *Angrabeg's commanding eye* to ward off the monster. He's careful to conceal his help from other party members, and remains invisible and hidden while assisting his new contractee.

Grishnaz usually arranges things so that his target is too desperate for help to read the contract before signing. A careful reading of the contract and a Knowledge (arcana) check (DC 30) reveal that not only is the contract one for perpetual service, but the penalties for attempting to avoid fulfilling it result in immediate and total forfeiture of all assets, both physical and spiritual. It's up to the GM as to how that works, or even if it works. GMs who don't feel like dealing with characters who've sold their souls to Hell can wuss out and simply say that Grishnaz is playing with the characters' heads for his own twisted amusement.

## The Wildlife

Most of the creatures on the island are imports from Hell, though a few were acquired from other parts of the mortal world through infernal trade networks. The fiendish creatures can be recognized for what they are by knowledgeable characters. A successful Knowledge (nature) check (DC 15) tells the character that they're not natural creatures, and a Knowledge (the planes) check (DC 20) reveals their origin.

The undead are made from the crews of the Imperial Navy ships that keep investigating the mysterious ship disappearances nearby. Bodies that don't meet Coyopultec's exacting standards are used as monster chow. As a result, the zombies and skeletons here are of very high quality.

## So, Where's Jack?

Well, as is so often the case, the forces of Darkness are playing a very complex game. Jack *has* returned from his watery grave, just as Coyopultec suspects. However, he's

missing some important information. The forces that allowed Jack to return have wiped his mind clean of the location of his treasure. As a result, he sails the sea, searching for it, and taking his frustrations out on every ship he finds...which was probably what the forces of Darkness had in mind. They're funny that way. The exact nature of Jack's return is up to the GM (or possibly the publisher of this adventure, if this thing proves popular).

## Camping Out, and The Consequences Thereof

Where the party chooses to set up camp will have a significant effect on how Coyopultec and company react to their incursions. As a general assumption, unless the party discovers Grishnaz following them and miraculously manages to fool him, Grishnaz will keep his side informed of their whereabouts and basic intentions.

By far the safest place to stay is on the ship. Parties willing to run the shark gauntlet every day can be assured that they'll sleep safely aboard ship, as long as they can trust the sailors. If the party sets up camp outside the dungeon, then they'll remain unmolested for the most part, except for the wildlife. Groups who stay in the monastery will have to deal with the shadow monks every night, but aside from that they should be fine. When they re-enter the dungeon, however, they'll find that all the traps have been reset, and any slain creatures will have been re-animated and placed back in their original places. Destroyed undead will have been replaced, except for the wights and spectres. Coyopultec and the chain devils will take full advantage of any free time to restore areas that have been cleared to functionality.

Parties that set up camp in the dungeon proper are in for an interesting time. With Grishnaz's guidance, patrols of undead will periodically attack throughout the night, always picking the worst possible moment and making it very difficult for spellcasters to regain their spells. Coyopultec will animate any corpses left in the party's wake, and then lead them to the party's encampment for a quick test run. This will continue until the party leaves the dungeon (so they can begin repairs) or Coyopultec and company run out of corpses.

All told, Coyopultec has enough parts to be able to animate an additional 25 skeletons and 17 zombies without going elsewhere for supplies. Should he run out of bodies in storage, he may sic the bone devils on the party's ship for a quick massacre/supply run. This could pose a problem for the party, once the adventure's over. Also, if the party's taken to sleeping on the ship, they may encounter the bone devils a bit early. Initial forays will simply involve a quick scout of the deck while *flying* and *invisible*, and then the devils will swoop down and snatch any isolated sailors who look like they're in good shape.

The chain devils won't head back into the dungeon to repair any damaged traps if the party's camped out in it. As they see it, they're engineers, not grunts. Should the party make a surprise run back into the dungeon while they're working, the chain devils will take the opportunity to take out their irritation on the fools who keep wrecking their handiwork.

# Player Beginning

*This nameless island looks much like the others you have passed, a stony peak rising out of the ocean, covered in verdant greenery. The captain assures you that it matches the coordinates on the map, however, and that this is your destination. On the leeward side, a wide lagoon offers safe anchorage for your vessel.*

## Level A: The Island

From the ship, the island looks normal, and seems identical to the island depicted on the map. The reefs around the island make landing anywhere but in the lagoon extremely problematic, and the ship's captain is unlikely to agree to such unnecessary maneuvers. Any characters making a Spot check (DC 18) will notice a cleared area in the jungle, about one third of the way up the north side of the mountain. The location of the clearing seems to correspond with the X marked on the map. Characters with access to magical vision enhancement, a spyglass, or better than normal eyesight can distinguish some sort of buildings in the clearing.

The captain of the ship may be interested in sending a few crew members ashore with the party to get fresh supplies of water and whatever game they can find, at the GM's discretion. The events in the lagoon will probably dissuade the captain from exploring this path further, though. The party will most likely be sent ashore on a landing craft, with two crew members as rowers. Larger parties (more than six members) will need to take two trips, as the captain is unlikely to want to risk more than one boat at a time. The party may attempt to persuade the captain otherwise, but unless they are in a position of authority (owners of the vessel, Imperial officers, etc.), this moves the captain's attitude one category toward hostile when making Charisma checks to influence his attitude.

### Wandering Monsters

Though there are many Tiny and Diminutive centipedes and spiders scuttling through the jungle, only Small ones will actively engage characters. The others flee anything larger than themselves. Few vermin survive long once they reach size Medium; the boars actively hunt down and destroy them once they get that large.

During daylight hours, there is a 10% chance (1-2 on a d20) per hour that the party will come across a random encounter while traveling through the jungle. This chance increases by +5% if they aren't being careful or are making noise, and by +10% if they're yelling or making extremely loud noises. At night these chances are doubled. If an encounter is called for, roll 1d8 and consult the following table. Roll hit points for each encounter separately.

1d8	Encounter
1-3	Fiendish small monstrous centipede
4-6	Fiendish small monstrous spider
7	Fiendish stirge
8	Fiendish dire boar

The following statistics blocks are provided for easy reference for the GM.

**Fiendish Small Monstrous Centipede:** Small Magical Beast; CR 1/4; HD 1/2d8; Init +2; Spd 30 ft., climb 30 ft.; AC 14, T 13, FF 12; Atk Bite +3 melee (1d4-3 plus poison), grapple -7; SA Poison, smite good (+1); SQ Darkvision 60 ft., vermin traits; AL NE; SV Fort +2, Ref +2, Will +0; Str 5, Dex 15, Con 10, Int 3, Wis 10, Cha 2.

*Skills and Feats:* Climb +10, Hide +14, Spot +4; Weapon Finesse.

**Fiendish Small Monstrous Spider:** Small Magical Beast; CR 1/2; HD 1d8; Init +3; Spd 30 ft., climb 20 ft.; AC 14, T 14, FF 11; Atk Bite +4 melee (1d4-2 plus poison), grapple -6; SA Poison, web, smite good (+1); SQ Darkvision 60 ft., tremorsense 60 ft., vermin traits, cold & fire resistance 5, SR 6; AL NE; SV Fort +2, Ref +3, Will +0; Str 7, Dex 17, Con 10, Int 3, Wis 10, Cha 2.

*Skills and Feats:* Climb +11, Hide +11, Jump -2, Spot +4; Weapon Finesse.

**Fiendish Stirge:** Tiny Magical Beast; CR 1/2; HD 1d10; Init +4; Spd 10 ft., fly 40 ft.; AC 16, T 16, FF 12; Atk Touch +7 melee (attach), grapple -11 (+1 when attached); SA Attach, blood drain, smite good (+1); SQ Darkvision 60 ft., low-light vision, cold & fire resistance 5, SR 6; AL NE; SV Fort +2, Ref +6, Will +1; Str 3, Dex 19, Con 10, Int 3, Wis 12, Cha 6.

*Skills and Feats:* Hide +14, Listen +4, Spot +4; Alertness, Weapon Finesse.

**Fiendish Dire Boar:** Large Magical Beast; CR 7; HD 10d8+30; Init +0; Spd 40 ft.; AC 15, T 9, FF 15; Atk Gore +15 melee (1d10+8), grapple +19; SA Ferocity, smite good (+10); SQ Low-light vision, scent, darkvision 60 ft., damage reduction 5/magic, cold & fire resistance 10, SR 15; AL NE; SV Fort +10, Ref +7, Will +8; Str 27, Dex 10, Con 17, Int 3, Wis 13, Cha 8.

*Skills and Feats:* Listen +9, Spot +10; Alertness, Endurance, Improved Natural Attack, Iron Will.

### Areas of the Map

#### Area A1 – Blood in the Lagoon (EL 5):

*As the landing craft speeds toward the sandy beach encircling the wide lagoon, a warm breeze carries the scent of the jungle across the water. The waters are crystal clear, and you can see the shadow of your boat cross the bottom of the lagoon, many feet below. Off to starboard, something splashes, disturbing the placid waters.*

A successful Spot check (DC 15) reveals a shark fin cutting the surface about 100 feet to starboard. If the character gets a 20 or better on the check, she notices that the fin looks wrong, with black skin flecked with red, and



serrated edges. Within seconds, the fin vanishes.

**Description:** The fiendish sharks are recent imports from the infernal realms, but have adapted well to the mortal world. Unfortunately, they've hunted the surrounding waters bare, and are getting hungry. Their hides are black, flecked with red, and their fins have serrated edges. Their eyes glow a dull red, radiating hungry malice. They're about 12 feet long, with jagged teeth that are unusually large even for sharks.

**Tactics:** The shark attacks when the boat is about halfway from the ship to the beach. The shark's first tactic is to bump the boat from below, attempting to knock someone into the water. Everyone sitting in the boat must make Reflex saves (DC 10) to avoid falling in. The DC for standing characters is 15. Anyone falling in will be attacked next round.

After a few unsuccessful rounds of bumping, the shark grows impatient and attempts to pull someone in. The shark leaps out to make a grapple attempt on someone, doing bite damage but incurring an attack of opportunity from the target (and adjacent characters) as usual. If the grapple attempt succeeds, on the next round the shark tries to pull the character in (with an opposed Strength check). Once a character is in the water, the shark concentrates its efforts on him.

Any injured character in the water may attract more sharks. Each round that an injured character stays in the water, there's a 10% chance that another shark will arrive, attracted by the blood.

Once the boat is ashore, the sailors probably won't want to take it back to the ship by themselves unless they know the shark is dead.

**Fiendish Shark:** Large Magical Beast; CR 4; HD 8d8+8; hp 61; Init +6; Spd Swim 60 ft.; AC 15, T 11, FF 13; Atk Bite +8 melee (1d8+3), grapple +13; SA Smite good (+8); SQ Blindsight 30 ft., keen scent, darkvision 60 ft., damage reduction 5/magic, cold & fire resistance 10, SR 13; AL NE; SV Fort +9, Ref +8, Will +3; Str 17, Dex 15, Con 13, Int 3, Wis 12, Cha 2.

*Skills and Feats:* Listen +8, Spot +8, Swim +11; Alertness, Great Fortitude, Improved Initiative.

**On The Beach:** The beach is quiet, the white sand utterly unmarked by footprints. At first glance, the wall of green jungle looks impenetrable, but a successful Survival check (DC 15) reveals the overgrown remnants of a trail leading into the trees.

The trail corresponds to the one marked on the map. Though it's thickly overgrown and requires clearing to be usable, it's still better than cutting through the trackless jungle. Movement rates are halved on the initial trip, but once the trail is cleared they increase to 3/4 of normal movement.

**Welcome To The Jungle:** The jungle is silent, except for the buzzing of flies. No chirping birds, no chattering animals, nothing but flies, the occasional oddly oversized centipede scuttling away into the brush, and the strangely regular spiderwebs that seem to decorate every tree. Though the undergrowth is thick and verdant, no flowers of any kind can be seen. Within 15 minutes, any characters with at least 5 ranks in Survival or Knowledge (nature) will realize that there's something wrong with this forest.

With a successful Survival or Knowledge (nature) check (DC 20), the cause is revealed. The ecology of this island is seriously out of balance. Something has destroyed most of the creatures that usually make up the ecological network of the island: birds, pollinating insects, and small reptiles. With a success of 25 or better, the character realizes that the unnatural-looking centipedes and spiders (fiendish monstrous centipedes and spiders, to be precise) are likely to be part of the cause.

#### Area A2 – One (not so) Little Piggie goes to Town! (EL 7):

*You've been cutting your way through the jungle for what seems like hours. The slope of the mountain is increasing, and the trees are growing farther apart. As you pause to catch a breath, you hear a snuffling sound from up ahead! An enormous pig-like creature bursts through the brush, squealing angrily, and charges you!*

Assuming that the party isn't being too noisy, a Listen check (DC 15) should warn them of the boar's approach in time to prepare for it.

**Description:** The herd of fiendish dire boars that rule the jungle are particular favorites of the imp Grishnaz, and instantly attack any living thing that they see. They have enormous tusks with serrated edges, hides black as pitch, and bristles as thick and sharp as wire. An infernal flame of hate burns in their eyes, and their breath smells of brimstone. Nearly 6 feet high at the shoulder, and almost 9 feet long, these monsters are living engines of destruction.

**Tactics:** The boar charges as soon as it sees any character, squealing with rage. It attacks until slain, focusing all its efforts on the first character it hits until that character drops, at which point the boar switches targets. Should the fight last longer than 5 rounds, there is a

cumulative 10% chance every subsequent round that another boar will hear the noise and arrive 10 rounds later. Should *that* fight last longer than 5 rounds, the pattern repeats itself. Careless parties could end up fighting the entire herd of 12.

**Fiendish Dire Boar:** Large Magical Beast; CR 7; HD 10d8+30; hp 87; Init +0; Spd 40 ft.; AC 15, T 9, FF 15; Atk Gore +15 melee (1d10+8), grapple +19; SA Ferocity, smite good (+10); SQ Low-light vision, scent, darkvision 60 ft., damage reduction 5/magic, cold & fire resistance 10, SR 15; AL NE; SV Fort +10, Ref +7, Will +8; Str 27, Dex 10, Con 17, Int 3, Wis 13, Cha 8.

*Skills and Feats:* Listen +9, Spot +10; Alertness, Endurance, Improved Natural Attack, Iron Will.

## Level B: The Monastery

Many centuries ago, an ancient order of monks built a monastery here, on the slopes of the mountain. They trained here in peace, honing their skills for many years, and instructing new generations of students. Several centuries ago, the monks came into conflict with a local tribe of sahuagin when they refused to pay tribute to the dark priest who led the scaly band of marauders. In a night of blood and fury, the sea demons destroyed the monastery, and the priest placed a powerful curse on it.

Since that night, the spirits of the long-dead monks have been doomed to haunt the ruins as shadows, slaying all who intrude on their grave. Even if they are destroyed, the shadow monks return the next night, unharmed. Bloody Jack felt that they made an excellent first line of defense, and so he made no effort to find a permanent solution, relying on Coyopultec to ward them off the work force.

### Areas of the Map

#### Area B1 – Outside The Gates:

*After what seems like hours, the last branch falls to your blades, and you step into a wide clearing. In the center lie the ruins of an ancient monastery, its crumbling walls surrounding an exercise yard and a single low building with a mostly intact roof. The plants here seem stunted, and die away before reaching the walls. Off to the right, you can see the ocean glittering in the sun, but here the air is still. Even the ever-present flies seem to avoid this place.*

If the party is being pursued by any of the infernal dire boars, the beasts stop short at the tree line and refuse to enter the clearing. Any natural animals that accompany the party also refuse to enter the clearing. Familiars will enter, but only with their master, and with noticeable discomfort.

The walls are about 8 feet high, though in several places they have collapsed entirely. There are no gates; even the hinges have long since rusted away to nothing.

The ground near the walls is totally bare of vegetation, and the earth seems dry and powdery.

#### Area B2 – Ruined Gardens:

*The 90 foot by 70 foot area encircled by the walls is an expanse of bare earth, separated by cracked stone pathways and punctuated by the occasional long-dead tree. Most of the trees have had their branches hacked off at some point in the past.*

A Search check (DC 20) discovers several blackened spots on the ground at various points, most likely the sites of the campfires of prior expeditions. The most recent appears to be many years old.

#### Area B3 – Monk Cells:

*Against the inside of the walls on both sides of the exercise yard are a series of empty 10 foot square cells. All are in poor repair, doorless and roofless. A few have bits of graffiti scratched into the walls; sailors' names, rude suggestions involving the habits of Imperial officers, and one rather well-done poem in Elven celebrating the exploits of some adventurers that you've never heard of. Other than that, they contain nothing but dust and rubble.*

These cells contain nothing of interest. Didn't you read the text above?

#### Area B4 – Meditation Room (EL 8):

*As you move toward the 30 foot by 60 foot building, you notice the salty smell of the ocean emanating from the shadowy interior. The windowless stone walls are interrupted only by the wide, empty doorway. Stepping inside, your eyes are caught by the series of black figures painted on the inner walls: shadowy combatants captured in mid-battle, illustrating strikes and blocks for long-dead students. A low stone dais close to the rear wall is the only other feature of this austere chamber. As you step closer, something flickers in the corner. Four of the*

*figures on the wall have torn themselves free and are rushing toward you!*

The scent of sea salt is much stronger in here than outside. Behind the dais, a secret trapdoor lies hidden in the floor. A Search or Spot check (DC 15) will discover the latch that opens it. A character with stonemasonry or Craft (stonemasonry) can easily tell that the trapdoor is much newer than the building. Beneath the door, stone stairs lead down into darkness. A strong smell of seawater rises up from the depths.

**Description:** The shadows are the remnants of the curse that destroyed the monastery several hundred years ago. They look like the shadows of monks, moving and striking as if they were using martial arts techniques.

**Tactics:** The four shadows that lurk here instantly attack anyone that enters. They concentrate on those inside the room, but will pursue fleeing characters outside. They refuse to leave the area enclosed by the walls, retreating to the meditation room and resuming their positions on the wall once all targets are dead or have fled the monastery.

**Shadows (4):** Medium Undead; CR 4; HD 6d12; hp 65, 58, 51, 42; Init +2; Spd Fly 40 ft. (good); AC 13, T 13, FF 11; Atk Incorporeal touch +5 melee (1d6 Str), grapple –; SA Create spawn, strength damage; SQ Darkvision 60 ft., incorporeal traits, +2 turn resistance, undead traits; AL CE; SV Fort +2, Ref +4, Will +6; Str –, Dex 14, Con –, Int 6, Wis 12, Cha 13.

*Skills and Feats:* Hide +10, Listen +8, Search +5, Spot +9; Alertness, Combat Reflexes, Dodge.

#### Area B5 – Into the Labyrinth (EL 6):

*The trapdoor opens into a stairway, leading deep into the mountain rock. The passageway is 10 feet wide and 8 feet tall. It extends downward for several hundred feet. The stairs are slick with algae and mold, requiring careful steps to avoid slipping and falling.*

*At the bottom of the stairs, the passageway opens into a 15 foot square room with an arched ceiling, 10 feet high at the peak. The floor is covered by a foot of black water, thick with algae, and nearly impossible to see through. Above you in the darkness is the sound of fluttering wings. As you look up, you see several small creatures drop from the ceiling and fly towards you, red eyes gleaming with hunger!*

The passageway and the chamber below are carved directly out of the stone. They're well finished, with smooth walls. There are 6 small drain ports (2 in each wall) in the walls of this chamber, about 3 feet above the floor. They're 6 inches wide.

The nest of fiendish stirges has been roosting here in safety for some time, squirming through the drains from the floor to hunt in the jungle above. They're perfectly

happy to enjoy a home-delivered meal, though.

Note that this room contains a trap. If the characters move into the room to fight the stirges, they will probably trigger it. It is supposed to trigger in the midst of the fight. See below for details.

**Description:** These tiny beasts infest the entire island, above and below ground, preying on anything larger than they are. They resemble a distorted cross between a reptilian rat and a giant mosquito, with a leathery wingspan of nearly a foot and a half and a body about 10 inches long. Eight tiny legs end in wicked claws, and the flexible proboscis is barbed and razor-sharp. They stink of old blood and sulfur.

**Tactics:** These little monsters have only the simplest of tactics. Swoop down, latch on (attempting to smite good on the off chance it'll make a difference), and drink their fill. Once sated, the stirges flutter off to digest their meal, either heading up the stairs or crawling into the drains for safety.

**Fiendish Stirges (8):** Tiny Magical Beast; CR 1/2; HD 1d10; hp 7, 6 (x3), 4 (x2), 3 (x2); Init +4; Spd 10 ft., fly 40 ft.; AC 16, T 16, FF 12; Atk Touch +7 melee (attach), grapple -11 (+1 when attached); SA Attach, blood drain, smite good (+1); SQ Darkvision 60 ft., low-light vision, cold & fire resistance 5, SR 6; AL NE; SV Fort +2, Ref +6, Will +1; Str 3, Dex 19, Con 10, Int 3, Wis 12, Cha 6.

*Skills and Feats:* Hide +14, Listen +4, Spot +4; Alertness, Weapon Finesse.

The trap is located in the center of the room. When it opens, all the water in the room flows into the pit. Once it resets and closes, water begins to flow slowly from the drains in the walls, covering the floor with another foot of water. It's much cleaner now.

The pit trap drops into the sea tunnels (level C), allowing access to the rest of the dungeon.

Just below the edge of the pit trap, there is a secret door in the far wall of the pit. Finding it requires a Search check (DC 35) while the pit trap is open. The door opens into an access tunnel, leading to area E1 in the second labyrinth. It's only accessible by hanging from the edge of the pit while the trap is open, by clinging to the wall somehow, by using a spell, or making a Climb check (DC 30).

**Camouflaged Pit Trap:** CR 4; mechanical; location trigger (pressure plate in center of room, under water); automatic reset (2 rounds); Reflex save (DC 25) avoids; 30 ft. deep (drop into 10 ft. of water, no damage); Search DC 30 (underwater); Disable Device DC 25.

The pit trap's door is made of stone, with the following game statistics.

**Stone Trap Door:** 2" thick; hardness 8; HP 30; Break DC 30.

## Level C: The Sea Tunnels

These tunnels have been carved out of the mountain itself. The walls are worked stone, coated almost entirely with muck, seaweed, and algae. The round tunnels are 10 feet wide, and have small 6 inch wide drains about halfway up the sides, spaced 10 feet apart. Stonemasonry or a Craft (stonemasonry) check (DC 15) suggests that the construction work was done by dwarves. The drains are mostly covered by the muck on the walls, requiring a Spot check (DC 20) or a Search check (DC 15) to find.

The tunnels are filled with murky seawater, almost up to the 10 foot high ceiling. There is air at the top, but it varies between 6 inches to 2 feet, depending on the tides outside. The cycle takes roughly 12 hours to change from high to low. Light from above the water only extends visibility down 5 feet into the water, but a light source (*continual flame* or the like) held below the surface grants 10 feet of visibility. Darkvision only extends about 20 feet under the water, due to its murky state. None of these tunnels are lighted in any way.

All doors in this section are made of rusty iron bars, held in a grillwork of iron bars. The grillwork is large enough to allow characters to squeeze through with an Escape Artist check (DC 12 for Small characters, DC 20 for Medium). The doors and walls have the following game statistics.

**Worked Stone Wall:** 5' thick; hardness 8; HP 900; Break DC 65; Climb DC 30.

**Iron Bar Doors:** 1" thick iron bars; hardness 10; HP 30; Break DC 28; Open Lock DC 32; squeeze through with Escape Artist DC 12 (Small), DC 20 (Medium).

### Wandering Monsters

There is a 20% chance (1-4 on a d20) per hour that the party will come across a random encounter while moving through the tunnels. This chance increases by +10% if they aren't being careful or are making noise, and by +20% if they're yelling or making extremely loud noises. If an encounter is called for, roll 1d8 and consult the following table. Roll hit points for each encounter separately.

1d8	Encounter
1-3	Fiendish moray eel
4-6	Fiendish barracuda
7	Floating patch of green slime
8	Fiendish stirge

The following statistics blocks are provided for easy reference for the GM.

**Fiendish Moray Eel:** Small Magical Beast; CR 3; HD 4d8; Init +4; Spd Swim 40 ft.; AC 16, T 15, FF 12; Atk Bite +8 melee (1d4+1), grapple +0; SA Attach, smite good (+4); SQ Darkvision 60 ft., cold & fire resistance 5, damage resistance 5/magic, SR 9; AL NE; SV Fort +4, Ref +8, Will +2; Str 13, Dex 19, Con 11, Int 3, Wis 12, Cha 2.

*Skills and Feats:* Hide +11, Spot +7, Swim +9; Weapon Finesse, Toughness.

**Fiendish Barracuda:** Small Magical Beast; CR 3; HD 4d8+4; Init +3; Spd Swim 60 ft.; AC 17, T 17, FF 14; Atk Bite +7 melee (1d6+1), grapple +1; SA Smite good (+4); SQ Darkvision 60 ft., cold & fire resistance 5, damage resistance 5/magic, SR 9; AL NE; SV Fort +5, Ref +7, Will +2; Str 12, Dex 16, Con 13, Int 3, Wis 12, Cha 2.

*Skills and Feats:* Listen +6, Spot +6, Swim +9; Combat Reflexes, Weapon Finesse.

**Green Slime (CR 4):** A single patch of green slime deals 1d6 points of temporary Constitution damage per round while it devours flesh. On the first round of contact, the slime can be scraped off a creature (most likely destroying the scraping device), but after that it must be frozen, burned, or cut away (applying damage to the victim as well). Extreme cold or heat, sunlight, or a *remove disease* spell destroys a patch of green slime. Against wood or metal, green slime deals 2d6 points of damage per round, ignoring metal's hardness but not that of wood. It does not harm stone.

**Fiendish Stirge:** Tiny Magical Beast; CR 1/2; HD 1d10; Init +4; Spd 10 ft., fly 40 ft.; AC 16, T 16, FF 12; Atk Touch +7 melee (attach), grapple -11 (+1 when attached); SA Attach, blood drain, smite good (+1); SQ Darkvision 60 ft., low-light vision, cold & fire resistance 5, SR 6; AL NE; SV Fort +2, Ref +6, Will +1; Str 3, Dex 19, Con 10, Int 3, Wis 12, Cha 6.

*Skills and Feats:* Hide +14, Listen +4, Spot +4; Alertness, Weapon Finesse.

### Areas of the Map

#### Area C1 – Splashdown! (EL 7):

*The 30 foot fall down the narrow pit is interrupted by a terrific splash as you land in murky salt water. Desperately treading water, you wipe your eyes clear and look around in the faint light from the room above. You're in a 10 foot wide round tunnel,*

### The Air and Water Vents

All the levels of the complex are connected by a system of air and water vents. These vents are 6 inch wide tunnels that connect to the outside through tortuously complicated routes, allowing air and seawater to flow into and out of the complex. The vents are also the primary route for the stirges, centipedes, and spiders to travel between the upper levels and the island, and for the barracudas and morays to travel between the sea tunnels and the ocean. Grishnaz also uses the vents as his primary method of travel inside the complex. Though it's a tight squeeze, he's secure in the knowledge that he's the only one who can use them. They come in especially handy when he's shadowing an adventuring party.



filled nearly to the top with water. The tunnel extends off into the blackness as far as you can see. The walls are coated with slippery muck. Suddenly, you feel something move through the water near your feet.

*You're not alone in here.*

The pit trap above resets itself in 2 rounds, closing the door. It must be set off again, or be broken open to reach characters in the water. The barracudas have been here for a few days, recuperating from an encounter with the eels down the passageway. They're getting hungry.

**Description:** The barracudas are engaged in a never-ending war with the morays for dominion over the waterways in the dungeon. Both avoid the open sea, for fear of the sharks that have taken over the local waters. The barracudas look like 4 foot long silvery torpedoes with a mouthful of jagged teeth, black fins, and dull red eyes.

**Tactics:** The barracudas concentrate their attacks on the first person to land in the water, moving on once that person is dead. Only when they are attacked by others do they split up and return the attack. They do not retreat, attacking until slain.

**Fiendish Barracudas (4):** Small Magical Beast; CR 3; HD 4d8+4; hp 27, 22, 17 (x2); Init +3; Spd Swim 60 ft.; AC 17, T 17, FF 14; Atk Bite +7 melee (1d6+1), grapple +1; SA Smite good (+4); SQ Darkvision 60 ft., cold & fire resistance 5, damage resistance 5/magic, SR 9; AL NE; SV Fort +5, Ref +7, Will +2; Str 12, Dex 16, Con 13, Int 3, Wis 12, Cha 2.

*Skills and Feats:* Listen +6, Spot +6, Swim +9; Combat Reflexes, Weapon Finesse.

#### **Area C2 – A Nest of Eels (EL 8):**

*As you swim along the tunnel, avoiding the slimy walls, something brushes your ankles. Looking down, you see small eel-like creatures swimming up from the bottom, snapping ferociously at your feet!*

The eels have been nesting here for several weeks. Their nest is a small pile of muck at the bottom of the tunnel, containing nothing but barracuda bones.

**Description:** The morays are engaged in a never-ending war with the barracudas for dominion over the waterways in the dungeon. They look like finned serpents with narrow, skull-like heads. Their fine scales are black and green, and their eyes glow yellow in the dark water.

**Tactics:** The eels have only rudimentary tactics, splitting up to attack as many targets as possible. Strong resistance will persuade them to retreat, seeking a less popular passageway.

**Fiendish Moray Eels (5):** Small Magical Beast; CR 3; HD 4d8; hp 28, 22 (x2), 19, 16, 14; Init +4; Spd Swim 40 ft.; AC 16, T 15, FF 12; Atk Bite +8 melee (1d4+1), grapple +0; SA Attach, smite good (+4); SQ Darkvision 60 ft., cold & fire resistance 5, damage resistance 5/magic, SR 9; AL NE; SV Fort +4, Ref +8, Will +2; Str 13, Dex 19, Con 11, Int 3, Wis 12, Cha 2.

*Skills and Feats:* Hide +11, Spot +7, Swim +9; Weapon Finesse, Toughness.

#### **Area C3 – The Chuul Pool (EL 9):**

*The tunnel opens into a wider chamber here. The chamber is 60 feet wide at the top, but the tunnel opens into a 40 foot wide pool in the center of the room. The pool is about 6 feet deep, filled with the same murky water that flows through the tunnels. The pool is surrounded by a 10 foot wide shelf that*

## **Underwater Combat**

Aside from the problem of breathing, adventuring underwater has many complicating factors. This is a brief review of underwater combat rules.

Surface-dwelling races face problems with both sight and sound when adventuring below the waves. In clear water, close to the surface during the day, the farthest they can see is 100 feet. Murky water cuts this to 50 feet, and at night or in darkened conditions (such as in a water-filled tunnel), surface dwellers can only see 10 feet even with a light source. Though sound travels farther underwater, the distance that surface dwellers can hear is halved, and individual sounds like speech are nearly indistinguishable. Without magical assistance, they cannot speak intelligibly at all.

Surface dwellers also suffer a –4 circumstance penalty to all Reflex saves, Dex-based checks, and Initiative rolls made underwater. They also suffer a –4 penalty to all attack and damage rolls. Piercing weapons do not suffer this penalty to damage. Shields are not usable underwater. Non-piercing ranged weapons are also unusable underwater, and all ranged weapons have their range increments reduced to 10% of their normal value, unless specially designed for underwater combat.

Spellcasters underwater face a number of challenges. Many spell effects are altered by the environment, and the process of casting is significantly inhibited. Verbal components are unusable by anyone unable to communicate normally underwater, and a Concentration check (DC 12) is required for any somatic components. Also, certain material components are ruined by immersion in water, but this is largely a matter of GM's discretion.

slopes down slightly to meet the water's edge. The ceiling is 15 feet high. Directly ahead, to the east, you can see the top of another tunnel entering the room and two more immediately to your right and left. As you enter the room, something large lunges from the shelf over the tunnel you entered from!

The chuul is a recent acquisition, and has yet to encounter any serious opposition. If surprised, it is lounging on the shelf, idly dabbling its claws in the water. It has presented some discipline problems by attempting to escape on numerous occasions, however, and Coyopultec and Grishnaz are considering replacing it with something less troublesome.

The doors are all locked. The northern tunnel is a dead-end, placed there simply to lure characters into the spear trap (see below).

**Description:** The chuul looks like a cross between a lobster and a preying mantis. Where one would expect mandibles, it has a mouthful of writhing tentacles, dripping with paralytic goo. The irregular pattern of black and green that covers its carapace blends in well with the slime-covered walls. Standing at full height, the chuul is nearly 8 feet tall at the shoulder, and has an arm (claw?) span of nearly 10 feet.

**Tactics:** Unless the chuul is surprised by a party moving without lights and being very quiet in opening the doors, it is waiting for the party on the shelf over the tunnel entrance. Once the party has entered the room, it lunges for the largest character and tries to grapple her. If it succeeds, next round it passes her to its tentacles, attempting to paralyze her, while attacking the next largest character. Once a character is paralyzed, the chuul flings her into the pool to drown, while repeating the pattern until it runs out of targets. It stays on the shelf whenever possible. If seriously in danger, the chuul tries to squeeze through the open doorway into the tunnel to escape.

**Fiendish Chuul:** Large Aberration; CR 8; HD 11d8+44; hp 102; Init +7; Spd 30 ft., swim 20 ft.; AC 22, T 12, FF 19; Atk 2 claws +12 melee (2d6+5), grapple +17; SA Constrict 3d6+5, improved grab, paralytic tentacles (DC 19), smite good (+11); SQ Amphibious, darkvision 60 ft., immunity to poison, damage reduction 5/magic, cold & fire resistance 10, SR 16; AL CE; SV Fort +7, Ref +6, Will +9; Str 20, Dex 16, Con 18, Int 10, Wis 14, Cha 5.

*Skills and Feats:* Hide +13, Listen +11, Spot +11, Swim +13; Alertness, Blind-Fight, Combat Reflexes, Improved Initiative.

**Exits:** The door directly to the north is trapped. It attacks the 10 foot space just inside the entrance to the tunnel.

**Pinning Spears Trap:** CR 7; mechanical; touch trigger (lock on door); automatic reset (1 hour); Atk +15 melee (1d8+4, spear/any target hit must make Reflex save DC 20 or be pinned to wall by spear); multiple targets (1d8 spears per target in 10 ft. by 10 ft. space); Search DC 25; Disable Device DC 25.



#### Area C4 – Octopus Garden (EL 10):

*The tunnel lets out near the top of a 40 foot wide round chamber. The ceiling is 30 feet from the floor, but water fills the chamber except for the top 2 or 3 feet. The only exits are the tunnel you entered from and a 10 foot wide opening into a vertical tunnel in the center of the ceiling, leading upward into darkness. Set into the north side of the tunnel is a ladder made of semicircular iron rungs sticking out of the stone wall. As you venture into the room, something wraps itself around your ankle and tugs gently, then much more strongly!*

The octopus is one of the oldest residents of the complex, being generally well behaved and comfortable with its lot. If the door to the chuul's room is left open, it will pursue prey down the corridor, but won't attempt to escape.

**Description:** The octopus' hide is mottled black and gray, and its eyes glow a poisonous green. The suckers on its tentacles are edged with razor-sharp teeth, and the beak is jagged. The tentacles stretch at least 10 feet from end to end.

**Tactics:** The octopus hides at the bottom of the chamber, waiting for intruders to reach the center of the room. Once the party is within the room, the octopus attacks as many different targets as it can manage, trying to grapple them all and pull them under. It's clever enough to recognize religious symbols and target their bearers with its smite good ability. It uses its beak to bite who-

ever's struggling the hardest. It stays underwater as long as it can manage, only reaching above the surface to pursue characters who attempt to escape up the tunnel in the ceiling. The octopus will eagerly pursue fleeing characters down the tunnel to the chuul's room.

**Fiendish Giant Octopus:** Large Magical Beast; CR 10; HD 10d8+13; hp 84; Init +6; Spd 20 ft., swim 30 ft.; AC 18, T 11, FF 16; Atk 8 Tentacle +10 melee (1d4+5) and bite +5 melee (1d8+2), grapple +15; SA Improved grab, constrict, smite good (+10); SQ Ink cloud, jet, low-light vision, darkvision 60 ft., cold & fire resistance 10, damage resistance 5/magic, SR 15; AL NE; SV Fort +8, Ref +9, Will +4; Str 20, Dex 15, Con 13, Int 3, Wis 12, Cha 3.

*Skills and Feats:* Escape Artist +12, Hide +13, Listen +4, Spot +7, Swim +13; Alertness, Improved Initiative, Skill Focus (Hide), Toughness.

**Exits:** The tunnel in the ceiling leads to room D1 in the Labyrinth. The rungs are made of the same iron as the bars of the doors, and have the same game characteristics. The walls are slick with moisture and mildew. Of course, there's a trap at the top of the ladder.

**Tunnel Scythe Trap:** CR 5; mechanical; touch trigger (top rung of ladder); automatic reset; hidden switch bypass (Search DC 25); Atk +16 melee (2d4+8/x4, scythe); Search DC 25; Disable Device DC 25.

#### Area C5 – Eel Mama's House (EL 9):

*The tunnel lets out near the top of a 40 foot wide round chamber. The ceiling is 30 feet from the floor, but water fills the chamber except for the top 2 or 3 feet. The only exits are the tunnel you entered from and a 10 foot wide opening into a vertical tunnel in the center of the ceiling, leading upward into darkness. Set into the north side of the tunnel is a ladder made of semicircular iron rungs sticking out of the stone wall. As you enter the chamber, the water ripples suddenly and a large snakelike head lunges out at you!*

Buried in the muck at the center of this room is a nest containing 7 large eggs. The giant moray spends most of her time curled around them, only taking brief breaks to devour anything that enters the room. The eggs could be quite valuable, if they could be safely transported. An Appraise check (DC 20) or a Knowledge (animals) check (DC 17) suggests that, to the correct buyer, they could be worth 2,000 gp apiece.

**Description:** Nearly 30 feet long, the giant moray has pure black scales on her body and a silvery head that looks like a long, narrow skull. Her eyes glow with a cold yellow light.

**Tactics:** The giant moray is fiercely protective of her eggs, viciously attacking whoever enters the chamber. She'll attach herself, smite good, and attempt to grapple her first target, before dragging him underwater to drown. If anyone goes after her eggs, or even moves toward the center of the room, she'll drop her victim and attack them instead. She won't pursue characters out of the room.

**Fiendish Giant Moray Eel:** Huge Magical Beast; CR 8; HD 16d8+80; hp 146; Init +5; Spd swim 60 ft.; AC 18, T 9, FF 17; Atk Bite +21 melee (2d6+11), grapple +31; SA Attach, smite good (+16); SQ Low-light vision, darkvision 60 ft., damage reduction 10/magic, cold & fire resistance 10, SR 21; AL NE; SV Fort +17, Ref +11, Will +6; Str 33, Dex 13, Con 21, Int 3, Wis 12, Cha 2.

*Skills and Feats:* Hide +7, Swim +19, Spot +11; Alertness, Dodge, Great Fortitude, Improved Initiative, Mobility, Power Attack.

**Exits:** The tunnel in the ceiling leads to room D4 in the Labyrinth. The rungs are made of the same iron as the bars of the doors, and have the same game characteristics. The walls are slick with moisture and mildew. And there's yet another trap at the top.

**Tunnel Scythe Trap:** CR 5; mechanical; touch trigger (top rung of ladder); automatic reset; hidden switch bypass (Search DC 25); Atk +16 melee (2d4+8/x4, scythe); Search DC 25; Disable Device DC 25.

## Level D: The First Labyrinth

The hallways that make up this labyrinth are finely worked stone, carved out of the living rock of the mountain. They're 10 feet wide and 8 feet tall, and stonemasonry or a Craft (stonemasonry) check (DC 15) suggests that the work was done by dwarves. There are 6 inch air holes in the walls, located every 10 feet along the walls about 1 foot below the ceiling. The floors are littered with the shattered remnants of countless bugs devoured by their competitors in the endless war between centipede and spider. Dusty cobwebs adorn the ceilings and walls. None of these rooms or corridors are lighted.

All doors in this section are made of iron bars held in a grillwork. The grillwork is large enough to allow characters to squeeze through with an Escape Artist check (DC 12 for

Small characters, DC 20 for Medium). The doors and walls have the following game statistics.

**Worked Stone Wall:** 5' thick; hardness 8; HP 900; Break DC 65; Climb DC 25.

**Iron Bar Doors:** 1" thick iron bars; hardness 10; HP 30; Break DC 28. Open Lock DC 27; squeeze through with Escape Artist DC 12 (Small), DC 20 (Medium).

### Level Tactics

Undead patrols make regular passes through the complex every 8 hours, and make feeding runs to the monster rooms every night at midnight. They also make random passes through the halls, with the chance of a patrol determined by

rolling dice for wandering monsters (see below). Patrols are drawn from the undead in the barracks (area D6). Destroyed patrols should be subtracted from those forces.

The undead troops are arrayed in recognizable Imperial marine gear. The zombies and skeletons are unusually sturdy, and the wights possess the combination of elán and arrogance that characterizes Imperial officers. Apparently, the attitude outlasts a mortal lifespan.

Patrol stats:

**Wight:** Medium Undead; CR 3; HD 5d12; Init +1; Spd 20 ft.; AC 19, T 11, FF 18; Atk Slam +3 melee (1d4+1 plus energy drain), grapple +3; SA Create spawn, energy drain; SQ Darkvision 60 ft., undead traits; AL LE; SV Fort +1, Ref +2, Will +5; Str 12, Dex 12, Con –, Int 11, Wis 12, Cha 15.

*Skills and Feats:* Hide +6, Listen +8, Move Silently +13, Spot +8; Alertness, Blind-Fight.

*Possession:* Scale armor.

**Human Marine Skeletons (4):** Medium Undead; CR 1; HD 1d12; Init +7; Spd 20 ft.; AC 21, T 13, FF 18; Atk Cutlass +2 melee (1d6+2/18-20) or claw +2 melee (1d4+2), grapple +2; SA –; SQ Damage reduction 5/bludgeoning, darkvision 60 ft., immunity to cold, undead traits; AL NE; SV Fort +0, Ref +3, Will +2; Str 15, Dex 16, Con –, Int –, Wis 10, Cha 1.

*Skills and Feats:* –; Improved Initiative.

*Possessions:* Scale armor, cutlass, heavy steel shield.

**Human Marine Zombies (4):** Medium Undead; CR 1; HD 2d12; Init +1; Spd 20 ft.; AC 17, T 11, FF 16; Atk Cutlass +4 melee (1d6+3/18-20) or slam +4 melee (1d6+3), grapple +4; SA –; SQ Single actions only, damage reduction 5/slashing, darkvision 60 ft., undead traits; AL NE; SV Fort +0, Ref +1, Will +3; Str 17, Dex 12, Con –, Int –, Wis 10, Cha 1.

*Skills and Feats:* –; Toughness.

*Possessions:* Scale armor, cutlass.

## Wandering Monsters

Though there are many Tiny and Diminutive centipedes and spiders scuttling through the hallways, only Small ones will actively engage characters. The others flee anything larger than themselves. Few vermin survive long once they reach size Medium; either settled monsters or patrols kill them.

There is a 15% chance (1-3 on a d20) per hour that the party will come across a random encounter while moving through the hallways. This chance increases by +5% if they aren't being careful or are making noise, and by +15% if they're yelling or making extremely loud noises. If an encounter is called for, roll 1d8 and consult the following table. Roll hit points for each encounter separately.

1d8	Encounter
1-3	Fiendish small monstrous centipede
4-6	Fiendish small monstrous spider
7	Fiendish stirge
8	Undead patrol (see above)

The following statistics blocks are provided for easy reference for the GM.

**Fiendish Small Monstrous Centipede:** Small Magical

Beast; CR 1/4; HD 1/2d8; Init +2; Spd 30 ft., climb 30 ft.; AC 14, T 13, FF 12; Atk Bite +3 melee (1d4-3 plus poison), grapple -7; SA Poison, smite good (+1); SQ Darkvision 60 ft., vermin traits; AL NE; SV Fort +2, Ref +2, Will +0; Str 5, Dex 15, Con 10, Int 3, Wis 10, Cha 2.

*Skills and Feats:* Climb +10, Hide +14, Spot +4; Weapon Finesse.

**Fiendish Small Monstrous Spider:** Small Magical Beast; CR 1/2; HD 1d8; Init +3; Spd 30 ft., climb 20 ft.; AC 14, T 14, FF 11; Atk Bite +4 melee (1d4-2 plus poison), grapple -6; SA Poison, web, smite good (+1); SQ Darkvision 60 ft., tremorsense 60 ft., vermin traits, cold & fire resistance 5, SR 6; AL NE; SV Fort +2, Ref +3, Will +0; Str 7, Dex 17, Con 10, Int 3, Wis 10, Cha 2.

*Skills and Feats:* Climb +11, Hide +11, Jump -2, Spot +4; Weapon Finesse.

**Fiendish Stirge:** Tiny Magical Beast; CR 1/2; HD 1d10; Init +4; Spd 10 ft., fly 40 ft.; AC 16, T 16, FF 12; Atk Touch +7 melee (attach), grapple -11 (+1 when attached); SA Attach, blood drain, smite good (+1); SQ Darkvision 60 ft., low-light vision, cold & fire resistance 5, SR 6; AL NE; SV Fort +2, Ref +6, Will +1; Str 3, Dex 19, Con 10, Int 3, Wis 12, Cha 6.

*Skills and Feats:* Hide +14, Listen +4, Spot +4; Alertness, Weapon Finesse.

## Areas of the Map

### Area D1 – Spider Mama's House (EL 8):

*This round room is 50 feet wide and 30 feet tall. The only exits are a barred iron door on the north wall and the tunnel entrance in the center of the floor. The ceiling overhead is shrouded in gray webbing, as are the walls. As you gingerly enter the room, something huge stirs in the webs overhead!*

This monster is the mother of all the spiders on the island. Her next egg sack hangs directly over the hallway door, and is nearly ready to hatch. Any direct attack on the web has a 50% chance per attack of dislodging it. When the egg sack hits the floor, it hatches out hundreds of Diminutive spiders that form a ravenous swarm and begin attacking the closest character.

**Description:** The great spider matriarch is nearly the same grayish black as her webs. Her legs span 16 feet across, and her eyes glitter a poisonous black. Her carapace is lined with wicked barbs and hooks. The swarm looks like a boiling cloud of tiny spiders, all scurrying over one another to devour you in a ravenous frenzy.

**Tactics:** The spider hides in the webs until after several characters have entered the room. She then spits a web at the characters, before quickly climbing down to do battle. She attacks a different character every round, trying to poison as many characters as possible, before grappling and trying to drag individual characters up into her webs. She won't pursue characters out of the room, as long as she has at least one meal in her grasp. The swarm will happily pursue fleeing characters.

**Fiendish Huge Monstrous Spider:** Huge magical Beast; CR 8; HD 11d8+22; hp 79; Init +7; Spd 30 ft., climb 20 ft.; AC 16, T 11, FF 13; Atk Bite +9 melee (3d6+6), grapple +19; SA Poison, web, smite good (+11); SQ Darkvision 60 ft., tremorsense 60 ft., vermin traits, damage reduction 5/magic, cold & fire resistance 10, SR 16; AL NE; SV Fort +9, Ref +6, Will +3; Str 19, Dex 17, Con 14, Int 3, Wis 10, Cha 2.

*Skills and Feats:* Climb +12, Hide +7 (+15 in web), Jump +8, Spot +12; Improved Initiative, Improved Natural Attack, Skill Focus (Hide), Skill Focus (Spot).

**Fiendish Spider Swarm:** Diminutive Magical Beast (swarm); CR 1; HD 2d8; hp 13; Init +3; Spd 20 ft., climb 20 ft.; AC 17, T 17, FF 14; Atk Swarm (1d6 plus poison), grapple -; SA Distraction, poison, smite good (+2); SQ Darkvision 60 ft., swarm traits, tremorsense 30 ft., vermin traits, cold & fire resistance 5, SR 7; AL NE; SV Fort +3, Ref +3, Will +0; Str 1, Dex 17, Con 10, Int 3, Wis 10, Cha 2.

*Skills and Feats:* Climb +11, Listen +4, Spot +4; -.

### Area D2 – Guard Station 1 (EL 8):

*This 30 foot by 40 foot room is nearly spotless. The ceiling is 12 feet high, and there are no webs or vermin fragments to be seen. There are three exits, one in the center of the north, east, and south walls, all without doors. As you set foot inside the room, an uncanny chill suddenly fills the air, a cold voice cries “Charge!” and ghastly undead figures wearing Imperial issue Marine scale armor attack from both sides of the entrance!*

There is also a trap at the door's entrance (see below).

The wight here spends much of its time inspecting and reviewing its troops, ensuring that they and their station are shipshape. Some habits carry over from life into unlife, and these creatures retain many of the behaviors that marked them as Imperial non-commissioned officers. When they are not cleaning the room under the wight's supervision, the undead troops stand in an eternal parody of attention.

**Description:** The wight retains the bearing of the Imperial officer it once was. Its armor is nearly spotless, and it does its best to keep its troops as well kept as it is. Where ordinary wights crouch and scurry, it strides with bold purpose. Most of the zombie troops have the extensive crude tattoos and shaved heads of career Imperial Marines.

**Tactics:** If the wight is aware of intruders before they reach the room, it arranges the zombie and skeleton troops on either side of the entrance that it expects the party to enter from, and waits in the corridor leading to room D6. Once the party enters and sets off the *deseccrate* trap, it orders the charge. The wight stands back from the initial press of battle, watching to see how well the party handles itself. If the characters do poorly, the wight attempts to capture one or two alive, but leaves the rest to be slain. If the party does well, it stays back, observing their tactics. If the party overwhelms the





troops, it attempts to flee and warn the other wights in room D6. It's careful not to use the secret doors if the party can see it.

**Trap:** The trap is triggered by anyone entering the room. The wight doesn't bother to avoid setting it off by accident, as it finds the sensation soothing.

**Desecrate Trap:** CR 4; magic device; proximity trigger (*alarm*); automatic reset; spell effect (*desecrate*, 8th level cleric); Search DC 27; Disable Device DC 27.

**Wight:** Medium Undead; CR 3; HD 5d12; hp 43; Init +1; Spd 20 ft.; AC 19, T 11, FF 18; Atk Slam +3 melee (1d4+1 plus energy drain), grapple +3; SA Create spawn, energy drain; SQ Darkvision 60 ft., undead traits; AL LE; SV Fort +1, Ref +2, Will +5; Str 12, Dex 12, Con -, Int 11, Wis 12, Cha 15.

*Skills and Feats:* Hide +6, Listen +8, Move Silently +13, Spot +8; Alertness, Blind-Fight.

*Possessions:* Scale armor, door key.

**Human Marine Skeletons (6):** Medium Undead; CR 1; HD 1d12; hp 9, 8, 5 (x3), 4; Init +7; Spd 20 ft.; AC 21, T 13, FF 18; Atk Cutlass +2 melee (1d6+2/18-20) or claw +2 melee (1d4+2), grapple +2; SA -; SQ Damage reduction 5/bludgeoning, darkvision 60 ft., immunity to cold, undead traits; AL NE; SV Fort +0, Ref +3, Will +2; Str 15, Dex 16, Con -, Int -, Wis 10, Cha 1.

*Skills and Feats:* -; Improved Initiative.

*Possession:* Scale armor, cutlass, heavy steel shield.

**Human Marine Zombie (6):** Medium Undead; CR 1; HD 2d12; hp 25, 21 (x2), 17, 15 (x2); Init +1; Spd 20 ft.; AC 17, T 11, FF 16; Atk Cutlass +4 melee (1d6+3/18-20) or slam +4 melee (1d6+3), grapple +4; SA -; SQ Single actions only, damage reduction 5/slashing, darkvision 60 ft., undead traits; AL NE; SV Fort +0, Ref +1, Will +3; Str 17, Dex 12, Con -, Int -, Wis 10, Cha 1.

*Skills and Feats:* -; Toughness.

*Possessions:* Scale armor, cutlass.

#### Area D3 – The Bug Pit (EL 7):

*This round chamber is 20 feet wide and 10 feet high. The ceiling and walls are covered with spider webs, most of which are in disrepair. Something near the ceiling chitters angrily and scuttles down the wall toward you! It's a spider the size of a dog. As you dodge the webbing it spits toward you, the floor begins to give way beneath you...*

This spider has just claimed this room from the centipede that had been living here. It's still adjusting to the space, and hasn't realized that there is a swarm living in the pit. Details of the pit trap are below.

**Description:** The spider looks like a smaller version of the one in room D1, without quite so many hooks and barbs. The centipede swarm looks like a reddish black storm of writhing chitin, flailing, legs and snapping mandibles, filled with tiny specks of red light emanating from the eyes of these poisonous little horrors.

**Tactics:** The spider attempts to web the first person who enters the room, and then leaps at them, attacking ferociously. It's inexperienced, and has little in the way of tactics, concentrating on one target until either the character is paralyzed or the spider takes enough damage to put it in serious danger, at which point it attempts to flee the room.

**Pit Trap:** The swarm in the pit relentlessly attacks anything that lands in the pit, including the spider.

**Centipede Pit Trap:** CR 5; mechanical; location trigger (5 ft. square in center of room); automatic reset (instant); Reflex save (DC 25) avoids; 30 ft. deep (3d6, fall, plus fiendish centipede swarm at bottom); Search DC 25; Disable Device DC 25.

**Fiendish Small Monstrous Spider:** Small Magical Beast; CR 1/2; HD 1d8; hp 6; Init +3; Spd 30 ft., climb 20 ft.; AC 14, T 14, FF 11; Atk Bite +4 melee (1d4-2 plus poison), grapple -6; SA Poison, web, smite good (+1); SQ Darkvision 60 ft., tremorsense 60 ft., vermin traits, cold & fire resistance 5, SR 6; AL NE; SV Fort +2, Ref +3, Will +0; Str 7, Dex 17, Con 10, Int 3, Wis 10, Cha 2.

*Skills and Feats:* Climb +11, Hide +11, Jump -2, Spot +4; Weapon Finesse.

**Fiendish Centipede Swarm:** Diminutive Magical Beast (swarm); CR 5; HD 9d8-9; hp 54; Init +4; Spd 20 ft., climb 20 ft.; AC 18, T 18, FF 14; Atk Swarm (2d6 plus poison), grapple -; SA Distraction, poison, smite good (+9); SQ Darkvision 60 ft., immune to weapon damage, swarm traits, tremorsense 30 ft., vermin traits, damage reduction 5/magic, cold & fire resistance 10, SR 14; AL NE; SV Fort +5, Ref +7, Will +3; Str 1, Dex 19, Con 8, Int 3, Wis 10, Cha 2.

*Skills and Feats:* Climb +12, Spot +4; Weapon Finesse.

#### Area D4 – Invisible Mushrooms With Teeth (EL 8):

*This round room is 50 feet wide and 30 feet tall. The only exits are a barred iron door on the north wall and the tunnel entrance in the center of the floor. The ceiling overhead is shrouded in tattered gray webbing, as are the walls. The mostly eaten body of a large spider lies against the north wall, and there's a pile of rotting matter in front of the barred iron door. As you carefully enter the room, you hear the scuttling footsteps of several creatures charging toward you, but you see nothing!*

Unfortunately, the fungi refuse to eat the grotesque slurry of insects, fish, and decayed human flesh that the patrols feed to the stationary monsters, and as a result are almost starving. Grishnaz thinks it might be the fish that's putting them off, and is considering giving them one of the zombies to snack on. The fungi were very expensive, and he hates to lose such fascinating creatures to dietary finickiness.

The pile of matter in front of the door is made up of fish, bugs, and a human arm. All of it is very rotten, and characters searching through it must make a Fortitude save

(DC 15) every round or become nauseated.

**Description:** In life, the invisible phantom fungi look much like you'd expect: like an empty room trying to eat you. In death, they look like multi-legged mushrooms with gaping maws filled with very sharp teeth. They're all about 9 feet tall, and 5 feet wide, with 4 irregularly jointed legs.

**Tactics:** The fungi are far too hungry to bother with stratagems. They leap at anything that enters the room and begin devouring it before it hits the ground. All four attack the same target, and refuse to stop until they've devoured it completely. If the door is left open, once they've eaten their fill, they squeeze through and ram-page through the labyrinth, devouring everything in their path.

**Phantom Fungi (4):** Large Plant; CR 4; HD 6d8+30; hp 53, 47, 32, 26; Init -2; Spd 20 ft.; AC 15, T 9, FF 15; Atk Bite +9 melee (1d6+6), grapple +13; SA -; SQ Low-light vision, plant traits, greater invisibility; AL N; SV Fort +10, Ref +1, Will +2; Str 22, Dex 8, Con 20, Int 2, Wis 11, Cha 9.

*Skills and Feats:* Listen +5, Move Silently +10, Spot +5; Alertness, Combat Reflexes, Skill Focus (Move Silently).

#### Area D5 – Guard Station 2 (EL 8):

*This 30 foot by 40 foot room is nearly spotless. The ceiling is 12 feet high, and there are no webs or vermin fragments to be seen. There are three exits, one in the center of the north, west, and south walls, all without doors. As you set foot inside the room, an uncanny chill suddenly fills the air, a cold voice cries "Charge!" and ghastly undead figures wearing Imperial issue Marine scale armor attack from both sides of the entrance!*

This room is identical to area D2, including the desecrate trap. As with area D2, it is inhabited by a wight, 6 human marine skeletons, and 6 human marine zombies.

**Area D6 – The Barracks (EL 9):** The secret doors that access the barracks in room D6 are well crafted and require a Search check (DC 27) to find. One is located on the east wall to the north of room D2, and another is down the opposite corridor leading from area D5. The third door is concealed on the south wall of the corridor that runs east-west connecting the two hallways, directly opposite the corridor that leads to room D9.

Characters within 15 feet of the doors can make a Spot check (DC 16) to notice a strong smell of rotten fish and meat. Characters with the Scent ability receive a +6 bonus to the check. Characters who make the check and have been in room D4 will recognize the smell. The secret doors are made of stone, with the following game statistics.

**Secret Door:** 1" thick; hardness 8; HP 15; Break DC 30.

*This room is 40 feet by 50 feet, with a 12 foot high*

ceiling. There are no webs or vermin fragments to be seen anywhere. In one corner are three large metal buckets filled with a disgusting mess of fish, bugs, and rotten human flesh. The stench is almost enough to blind you. As you step into the room, a familiar uncanny chill fills the air, and a cold voice shouts "Charge!" as more undead troops pour into the room from the other corridor!

Entrance to this room triggers another *desecrate* trap (see below). There's also another secret door in this room, in the east wall. It requires a Search check (DC 30) to find. The door leads to D7.

The wights here follow much the same routine as the ones in the guard rooms. Constant inspections are interrupted only by periodic patrols, and occasional reports to Grishnaz in the second labyrinth. If either wight from rooms D2 or D5 has managed to escape the party, they'll be here.

**Description:** Much the same as the other guard units. The elite wight is, if possible, even *more* stiff-necked and military than the other wights. Though it carries an officer's longsword, this is simply an insignia of rank. Under most circumstances, it will use its slam attack.

**Tactics:** The wights keep a careful ear on the doors, especially if they have been warned of the party's approach by one of the wights from room D2 or D5. When they hear party members fiddling with the door, they quietly move the troops into the corridor opposite it. They then conceal themselves near the entrance and wait for the party to trip the *desecrate* trap. Then they order the charge. The elite wight stands back from the fray, but the other two eagerly join in. If the fight goes poorly, the elite wight slips out of the room to hide and wait for the party to leave so it can use the secret door in the east wall to warn the others in the second labyrinth.

**Trap:** The trap is triggered by anyone entering the room. The wights don't bother to avoid setting it off by accident, as they find the sensation soothing.

**Desecrate Trap:** CR 4; magic device; proximity trigger (*alarm*); automatic reset; spell effect (*desecrate*, 8th level cleric); Search DC 27; Disable Device DC 27.

**Elite Wight:** Medium Undead; CR 5; HD 8d12; hp 84; Init +3; Spd 30 ft.; AC 21, T 13, FF 18; Atk Slam +7 melee (1d6+3 plus energy drain) or longsword +7 melee (1d8+3/19-20/x2), grapple +7; SA Create spawn, energy drain; SQ Darkvision 60 ft., undead traits; AL LE; SV Fort +2, Ref +5, Will +7; Str 17, Dex 16, Con –, Int 12, Wis 12, Cha 17.

*Skills and Feats:* Hide +12, Listen +14, Move Silently +18, Spot +14; Alertness, Blind-Fight, Improved Natural Attack.

*Possessions:* Chain shirt, officer's sword, door key, set of dice.

**Wights (2):** Medium Undead; CR 3; HD 5d12; hp 50, 45; Init +1; Spd 20 ft.; AC 19, T 11, FF 18; Atk Slam +3

melee (1d4+1 plus energy drain), grapple +3; SA Create spawn, energy drain; SQ Darkvision 60 ft., undead traits; AL LE; SV Fort +1, Ref +2, Will +5; Str 12, Dex 12, Con –, Int 11, Wis 12, Cha 15.

*Skills and Feats:* Hide +6, Listen +8, Move Silently +13, Spot +8; Alertness, Blind-Fight.

*Possessions:* Scale armor, door key.

**Human Marine Skeletons (10):** Medium Undead; CR 1; HD 1d12; hp 10, 9 (x3), 7 (x2), 6, 5 (x2), 3; Init +7; Spd 20 ft.; AC 21, T 13, FF 18; Atk Cutlass +2 melee (1d6+2/18-20) or claw +2 melee (1d4+2), grapple +2; SA –; SQ Damage reduction 5/bludgeoning, darkvision 60 ft., immunity to cold, undead traits; AL NE; SV Fort +0, Ref +3, Will +2; Str 15, Dex 16, Con –, Int –, Wis 10, Cha 1.

*Skills and Feats:* –; Improved Initiative.

*Possessions:* Scale armor, cutlass, heavy steel shield.

**Human Marine Zombies (10):** Medium Undead; CR 1; HD 2d12; hp 26, 22 (x2), 19 (x3), 15, 14, 10, 7; Init +1; Spd 20 ft.; AC 17, T 11, FF 16; Atk Cutlass +4 melee (1d6+3/18-20) or slam +4 melee (1d6+3), grapple +4; SA –; SQ Single actions only, damage reduction 5/slashing, darkvision 60 ft., undead traits; AL NE; SV Fort +0, Ref +1, Will +3; Str 17, Dex 12, Con –, Int –, Wis 10, Cha 1.

*Skills and Feats:* –; Toughness.

*Possessions:* Scale armor, cutlass.

#### Area D7 – Behind the Hidden Door:

*This 10 foot wide tunnel extends 100 feet straight upwards. Semicircular iron rungs protrude from the east wall, providing a ladder. Four long chains dangle down from the ceiling far above, clanking slightly against each other as you stir the still air. The edges of the chains have been sharpened to a wicked edge.*

This tunnel leads up to the horizontal tunnel that enters the second labyrinth.

#### Area D8 – Chop Chop! (EL 7):

This hallway is trapped. The trap has a bypass switch on the east wall, just around the corner from the east-west hallway (Search DC 25). If the trap is activated, characters may attempt to Tumble down the corridor to avoid attack, as if Tumbling through an area threatened by an enemy. The multiple axes make the DC 30, but if they want to give it a try, let them go for it.

Characters will be able to smell the baboons from here. If any of them have ever encountered monkeys or apes before, they'll recognize the smell.

**Whirling Axes Trap:** CR 7; mechanical; location trigger (pressure pad in center of corridor); automatic reset (9 rounds); Atk +15 melee (1d12+8, greataxe); multiple targets (1d3 axes per target in every 5 ft. square of 10 ft. by 50 ft. corridor); continuing effect (once set off, attacks on 1st, 4th, 5th, and 8th rounds before resetting



on 9th round); hidden switch bypass (Search DC 25); Search DC 25; Disable Device DC 25.

#### Area D9 – The Monkey House (EL 9):

*This round room is 50 feet across and 30 feet high. A 10 foot deep and 35 foot wide section of the southern part of the room is enclosed behind a wall of iron bars, with a locked door in the center. There's a small 5 foot wide opening about half way up the north wall. The room is filthy beyond belief, with piles of dung everywhere and scraps of food scattered about. The stench is mindboggling. As you enter the room, a chorus of enraged shrieks erupts from the opening in the north wall, followed shortly by a flood of frothing baboons, who leap to the floor and charge you en masse!*

Characters must make Fortitude saves (DC 12) to avoid being nauseated for 1d4 rounds by the stench here. The baboons' favorite pastime, after flinging dung at each other, is tormenting the prisoner in room D10.

**Description:** The baboons are filthy by choice, their coarse reddish fur matted with the filth they decorate their room with. Their red eyes gleam with infernal malice.

**Tactics:** If the baboons have been alerted by noise from the corridor, then they all crowd into room D11, waiting eagerly for a new meal. Once the party has entered the room, they leap out and attack. They swarm the party, relying on superior numbers and ferocity to bring down the characters. They'll try to gang up on characters, flanking them when possible and occasionally trying to grapple a character to the ground so the others can attack her. The two half-fiend alphas from D11 stay in the alcove to observe for a few rounds. Once they've identified the strongest fighter, they fly out and try to grapple him together. If they succeed, they fly him up to the ceiling and drop him to the floor, after tagging him with *darkness*. Then they'll repeat it on the next strongest. They'll happily pursue fleeing party members out of the room. If the party prevails, the baboons' morale breaks once half their number has perished. They'll flee past the characters and out into the labyrinth to hide and lick their wounds, and plot revenge.

**Fiendish Baboons (11):** Medium Magical Beast; CR 1; HD 2d8+2; hp 17, 15 (x3), 12 (x2), 10, 9, 7 (x3), 5; Init +2; Spd 40 ft., climb 30 ft.; AC 13, T 12, FF 11; Atk Bite +3 melee (1d6+3), grapple +3; SA Smite good (+2); SQ Low-light vision, scent, darkvision 60 ft., cold & fire resistance 5, SR 7; AL LE; SV Fort +4, Ref +5, Will +1; Str 15, Dex 14, Con 12, Int 3, Wis 12, Cha 4.

*Skills and Feats:* Climb +10, Listen +6, Spot +5; Alertness.

#### Area D10 – Behind Bars (EL 9):

*Through the bars, you can see a large huddled figure lying curled in a fetal position against the wall. A thick chain, perhaps no more than three or four feet long, extends from the wall to its neck. The*

*interior of the cage is virtually a sea of filth, splattered on the walls and the bars. The unfortunate prisoner is coated in the foul stuff. Its only motion is to frantically claw at its head as it whimpers to itself.*

The chain is actually 10 feet long, but the ape has hidden most of it underneath himself. The chain is also one good pull away from breaking. The ape is a prisoner, sent here after being captured and interrogated during the endless wars between demons and devils in the lower planes. The powers that trade with Coyopultec offered him this unfortunate prisoner at a discount after they cut his wings off, drained him of any useful info, and grew bored with tormenting him. The ape is completely insane at this point. He ignores anything occurring in the room outside his cage.

There is a secret door in the wall behind the ape. A Search check (DC 17) finds it, since the ape's been clawing at the wall for years and has chipped away at the camouflage. The door leads to a 10 foot wide corridor that opens into room D12.

**Description:** The ape is coated with slime and putrid filth. Though he lost his wings long ago, the wounds on his back still ooze pus and blood. His demon heritage shows in the thick scales that cover his hide and the twisted horns that sprout from his skull.

**Tactics:** The ape continues to pretend catatonia despite provocation, even after being attacked from outside the cage. He knows what he wants. He'll keep the pose up until after being damaged for 1/4 of his hit points, at which point he flips out and charges the door. Fortunately for him, his chain breaks, freeing him to attempt to break down the door. This shouldn't be too hard, considering his strength. Once he's freed himself from the cage, he goes on a rampage, taking out decades of torment on every living (or undead) thing in his way.

If the party is foolish enough to actually *go in the cage*, well...laugh loudly, and tool them. Hard. Being merciful only encourages this kind of behavior.

**Half-fiend Dire Ape:** Large Outsider; CR 9; HD 11d8+44; hp 110; Init +6; Spd 30 ft., climb 15 ft.; AC 20, T 15, FF 14; Atk 2 claws +16 melee (1d6+10) and bite +11 melee (1d8+5), grapple +21; SA Rend 2d6+15, smite good (+11), *darkness* 3/day, *desecrate*, *unholy blight*, *poison* 3/day, *contagion*, *blasphemy*; SQ Low-light vision, scent, darkvision 60 ft., poison immunity, acid & cold & electricity & fire resistance 10, damage reduction 5/magic, SR 16; AL CE; SV Fort +11, Ref +13, Will +7; Str 31, Dex 22, Con 19, Int 8, Wis 3, Cha 8.

*Skills and Feats:* Bluff +6, Climb +32, Hide +13, Intimidate +6, Jump +17, Listen +10, Move Silently +20, Spot +10; Cleave, Combat Reflexes, Great Cleave, Power Attack.

#### Area D11 – The Hole in the Wall:

*This round chamber is 20 feet across and 10 feet high. The floor is coated with filth, but the walls*

*seem to have crude images painted on them, in the only medium available. The paintings show the baboons, led by their winged chiefs, slaughtering the ape and many humanoid figures, including one who seems to be wearing a long cloak and wielding a sword, and one small winged figure. In the flickering light, the images almost seem to move...*

The half-fiends spend most of their time here, plotting their revenge on, well, everyone in the world. They only emerge to torment the prisoner, to eat, and to attack the occasional intruder.

**Description:** Though they live in filth, the half-devil baboons keep themselves fairly clean. Their heads and shoulders sprout a thick mane of reddish hair, while the rest of their bodies are covered with green scales. Short black horns protrude from their brows, above gleaming red eyes.

**Half-fiend Baboons (2):** Medium Outsider; CR 2; HD 3d8+9; hp 29, 20; Init +6; Spd 40 ft., climb 30 ft., fly 40 ft. (average); AC 18, T 16, FF 12; Atk Bite +8 melee (1d6+6) and 2 claws +3 (1d4+3), grapple +8; SA Smite good (+3), *darkness* 3/day, *desecrate* 1/day; SQ Low-light vision, scent, darkvision 60 ft., poison immunity, acid & cold & electricity & fire resistance 10, damage reduction 5/magic, SR 13; AL LE; SV Fort +6, Ref +9, Will +1; Str 23, Dex 22, Con 17, Int 8, Wis 10, Cha 6.

*Skills and Feats:* Climb +20, Hide +9, Intimidate +4, Listen +8, Move Silently +9, Sense Motive +3, Spot +8; Alertness, Skill Focus (Intimidate).

### Area D12 – The Temple (EL 12):

*This oddly shaped room is 70 feet square and 40 feet high at the center. It's shaped like the inside of a hollow stepped pyramid. The room is filled with water surrounding a 30 foot square island in the middle of the room. On the island is a 20 foot high pyramid, and atop the pyramid is a 7 foot tall statue. The statue depicts a grossly muscled humanoid figure wearing a feathered cloak, wielding what looks like a broad saw-edged two-handed sword. Its head is a skull with stylized snakes for hair. The statue's eyes glow an awful red, seeming to fill the room with a palpable sense of menace.*

*A 5 foot wide causeway connects the corridor to the island. The water seems to be full of barracudas, and on the steps of the pyramid stand 20 skeletons in Imperial Marine scale armor, arranged in perfect ranks and standing at attention. Above them, on the penultimate level of the pyramid, stand 4 wizened figures wearing Imperial Marine officers' uniforms and armor, also at attention. Flying about the room are three ghostly figures, clad in piratical garb, cackling madly. One swoops toward you, shouting, "Well then, mateys, come for a tangle, have you? Come on, then! Ha ha ha!"*

This room is under the effect of an *unhallow* spell, which has been linked to a *bane* spell targeting all non-undead creatures in the room. The spell also affects the barra-

udas, but they're mostly window dressing anyway. A Knowledge (religion) check (DC 20) identifies the statue as an image of Coatlimict, a minor god of war and undeath from the Xulmec city-states far to the south. The Xulmec are known for building stepped pyramids much like the one in the center of the room.

The pirate spectres are the only survivors of the original inhabitants of the dungeon. While the rest of the creatures bound here by Bloody Jack fought to the death against Coyopultec, the pirates retained enough self-awareness to resent Jack's treachery and gladly joined forces with Coyopultec.

Beneath the statue is a 5 foot wide tunnel leading down to room D13. A Search check (DC 25) reveals that the statue isn't fixed in place. A Strength check (DC 25) moves the statue to one side, revealing the tunnel. There are iron rungs embedded in the wall, in much the same way as in the other vertical tunnels here.

**Description:** The spectres look and act much like the pirates they were in life, dressed with rakish flair and boldly flitting about the temple. They enjoy the *unhallowed* ambiance, and they never fail to take the opportunity to mock the stiff-backed wights, with their by-the-book attitude and straight-laced look. The wights, on the other hand, think it's beneath their dignity to respond to such provocation, and pretend the spectres aren't there at all. The skeletons and zombies pretty much just stare vacantly at the walls.

**Tactics:** The wights and skeletons wait, motionless, until the party crosses the causeway, ideally activating the stone hammers trap. The barracudas attack anyone knocked into the water, but they're not really enthusiastic about it. Once the party has reached the island, the skeletons move down and attack, under the supervision of the wights. The spectres swoop around, gleefully draining anyone wearing clerical regalia or religious symbols, and taunting the party. The wights order the skeletons to push characters into the water, and target the strongest fighters themselves, draining their targets nearly to death, before attempting to knock them unconscious. They do not retreat, fighting to their second death.

**Stone Hammers Trap:** CR 7; mechanical, location trigger (pressure pad 2/3rds along walkway), automatic reset (10 rounds); Atk +16 melee (3d6, hammer); Reflex save (DC 20) to avoid being knocked off walkway; multiple targets (1 per 5 ft. section of 20 ft. section of walkway); continuing effect (keeps attacking for 10 rounds); Search DC 30; Disable Device DC 27.

**Pirate Spectres (3):** Medium Undead; CR 8; HD 7d12; hp 79, 67, 58; Init +9; Spd 40 ft., fly 80 ft. (perfect); AC 17, T 17, FF 12; Atk Incorporeal touch +8 melee (1d8 plus energy drain), grapple –; SA Energy drain, create spawn; SQ Darkvision 60 ft., incorporeal traits, +2 turn resistance, sunlight powerlessness, undead traits, unnatural aura; AL LE; SV Fort +2, Ref +7, Will +7; Str –, Dex 20, Con –, Int 16, Wis 14, Cha 17.

*Skills and Feats:* Hide +15, Intimidate +13, Knowledge (religion) +13, Listen +14, Search +13, Spot +14, Survival +2 (+4 following tracks); Alertness, Blind-Fight, Improved Initiative.

**Elite Wights (4):** Medium Undead; CR 5; HD 8d12; hp 90, 83, 71, 65; Init +3; Spd 30 ft.; AC 21, T 13, FF 18; Atk Slam +7 melee (1d6+3 plus energy drain) or longsword +7 melee (1d8+3/19-20/x2), grapple +7; SA Create spawn, energy drain; SQ Darkvision 60 ft., undead traits; AL LE; SV Fort +2, Ref +5, Will +7; Str 17, Dex 16, Con –, Int 12, Wis 12, Cha 17.

*Skills and Feats:* Hide +12, Listen +14, Move Silently +18, Spot +14; Alertness, Blind-Fight, Improved Natural Attack.

*Possessions:* Chain shirt, officer's sword.

**Human Marine Skeletons (20):** Medium Undead; CR 1; HD 1d12; hp 11 (x2), 9 (x3), 8 (x3), 7 (x4), 6 (x3), 5 (x3), 4, 3; Init +7; Spd 20 ft.; AC 21, T 13, FF 18; Atk Cutlass +2 melee (1d6+2/18-20) or claw +2 melee (1d4+2), grapple +2; SA –; SQ Damage reduction 5/bludgeoning, darkvision 60 ft., immunity to cold, undead traits; AL NE; SV Fort +0, Ref +3, Will +2; Str 15, Dex 16, Con –, Int –, Wis 10, Cha 1.

*Skills and Feats:* –; Improved Initiative.

*Possessions:* Scale armor, cutlass, heavy steel shield.

**Fiendish Barracudas (20):** Small Magical Beast; CR 3; HD 4d8+4; hp 31 (x4), 26 (x4), 20 (x4), 17 (x4), 12 (x4); Init +3; Spd Swim 60 ft.; AC 17, T 17, FF 14; Atk Bite +6 melee (1d6+1), grapple +0; SA Smite good (+4); SQ Darkvision 60 ft., cold & fire resistance 5, damage resistance 5/magic, SR 9; AL NE; SV Fort +5, Ref +7, Will +2; Str 12, Dex 16, Con 13, Int 3, Wis 12, Cha 2.

*Skills and Feats:* Listen +6, Spot +6, Swim +9; Combat Reflexes, Weapon Finesse.

### Area D13 – Blob in the Box (EL 11):

*As you look down into this room, you see that it's 20 feet square. On the floor below is a huge steel chest, 10 feet wide, 5 feet deep, and 7 feet tall. The stone floor beneath it is oddly rippled and dented. Is this the treasure you've sought?*

Three things happen when the characters investigate the chest: (a) a poisoned needle trap springs when the lock is touched, (b) when the lid is lifted, the room begins to fill with water and mechanical bars appear to block the escape tunnel, and (c) a gibbering moulder is released from the chest.

Characters in the tunnel can make a Spot check (DC 14) to notice 8 one inch holes in the walls of the tunnel, about 1 foot up from where it enters the room. The holes extend into the wall about a foot. These are the basis of a mechanical bar trap triggered by opening the chest. The bars close off exit through the tunnel, the room fills with water, and then the characters are drowned.

The chest is made of steel plates, bolted together. It was assembled here, as there's no way it could have fit

down the tunnel. The floor is rippled from past episodes with the moulder.

This is one of Grishnaz's favorite spots for tempting characters to sign his contract. He often lurks in the tunnel, waiting for the water trap to spring, so he can make his offer to anyone who floats to the top. Being pressed against the bars while a gibbering moulder nibbles on your feet is a great encouragement to sign without reading the fine print too closely.

The needle trap on the chest is there to distract the party from the real dangers, the moulder and the water trap. Breaking 2 of the bars that block the tunnel's mouth creates enough room to squeeze through for a Medium character of normal build. The water flows in through the 4 drain holes near the ceiling, one in each wall.

**Description:** Picture a bowlful of bubbling, boiling, brownish snot, covered with glaring eyes and mouths filled with sharp teeth, all snapping at you, babbling insane nonsense and spitting acid in your face, while trying to eat you. Now, make it the size of an SUV. There's your gibbering moulder.

**Tactics:** Once released from the chest, the moulder attacks everyone within range. It'll try to engulf the person who opened the chest first, but it's not really picky. It doesn't have much in the way of strategy, but once the room starts to fill with water, it gets into the spirit a bit more, and starts swimming around, gaily pulling people under and engulfing them for a few minutes, before spitting them back out and gulping down someone else. The moulder feels that it's important to enjoy your work whenever possible.

**Poisoned Needle Trap:** CR 4; mechanical; touch trigger (fiddling with lock on chest); repair reset; Atk +15 melee (1 plus poison, needle); poison (medium-size spider venom, Fort save DC 14 resists, 1d4 Str/1d6 Str); Search DC 25; Disable Device DC 24.

**Water-Filled Room Trap:** CR 10; mechanical, touch trigger (lifting lid of chest); automatic reset (3 hours); multiple targets (all in 20-ft room); never miss; onset delay (3 rounds); water; Search DC 30; Disable Device DC 30.

*Additional effect:* This trap also triggers bars that close off the tunnel in the ceiling.

*4 Iron Bars:* 1" thick; hardness 10; HP 30; Break DC 28.

**Gibbering Moulder:** Large Aberration; CR 6; HD 8d8+64; hp 101; Init +0; Spd 10 ft., swim 20 ft.; AC 19, T 9, FF 19; Atk 6 bites +9 melee (1) and spittle +9 ranged touch (1d4 acid plus blindness), grapple +14; SA Gibbering, spittle, improved grab, blood drain, engulf, ground manipulation; SQ Amorphous, damage reduction 5/bludgeoning, darkvision 60 ft.; AL NE; SV Fort +10, Ref +4, Will +7; Str 18, Dex 11, Con 26, Int 4, Wis 13, Cha 13.

*Skills and Feats:* Listen +5, Spot +10, Swim +10; Ability Focus (Gibbering), Lightning Reflexes.

# Level E: The Second Labyrinth

The corridors here are made of worked stone, well crafted and maintained. The floors are free of debris, and the occasional spider web is quickly dealt with by the frequent patrols. Five foot long chains dangle from the ceiling every ten feet throughout this part of the complex. The doors are the same as those in the rest of the dungeon, though they're not as rusty. None of these rooms are lighted, except for the chain devils' forge.

**Worked Stone Wall:** 5' thick; hardness 8; HP 900; Break DC 65; Climb DC 25.

**Iron Bar Doors:** 1" thick iron bars; hardness 10; HP 30; Break DC 28; Open Lock DC 27.

## Level Tactics

Undead patrols make regular passes through the complex every 6 hours. They also make random passes through the halls, with the frequency determined by rolling dice for wandering monsters (see below). The patrols are drawn from the undead in the muster hall (area E2). Destroyed patrols should be subtracted from those forces.

## Wandering Monsters

There is a 15% chance (1-3 on a d20) per hour that the party will come across a patrol while moving through the corridors. This chance increases by +5% if they aren't being careful or are making noise, and by +15% if they're yelling or making extremely loud noises. The patrols check the corridors every hour. Roll hit points for each encounter separately. The patrol stats are as follows:

**Wight:** Medium Undead; CR 3; HD 5d12; Init +1; Spd 20 ft.; AC 19, T 11, FF 18; Atk Slam +3 melee (1d4+1 plus energy drain), grapple +3; SA Create spawn, energy drain; SQ Darkvision 60 ft., undead traits; AL LE; SV Fort +1, Ref +2, Will +5; Str 12, Dex 12, Con –, Int 11, Wis 12, Cha 15.

*Skills and Feats:* Hide +6, Listen +8, Move Silently +13, Spot +8; Alertness, Blind-Fight.

*Possession:* Scale armor.

**Human Marine Skeletons (4):** Medium Undead; CR 1; HD 1d12; Init +7; Spd 20 ft.; AC 21, T 13, FF 18; Atk Cutlass +2 melee (1d6+2/18-20) or claw +2 melee (1d4+2), grapple +2; SA –; SQ Damage reduction 5/bludgeoning, darkvision 60 ft., immunity to cold, undead traits; AL NE; SV Fort +0, Ref +3, Will +2; Str 15, Dex 16, Con –, Int –, Wis 10, Cha 1.

*Skills and Feats:* –; Improved Initiative.

*Possessions:* Scale armor, cutlass, heavy steel shield.

**Human Marine Zombies (4):** Medium Undead; CR 1; HD 2d12; Init +1; Spd 20 ft.; AC 17, T 11, FF 16; Atk Cutlass +4 melee (1d6+3/18-20) or slam +4 melee (1d6+3), grapple +4; SA –; SQ Single actions only, damage reduction 5/slashing, darkvision 60 ft., undead traits; AL NE; SV Fort +0, Ref +1, Will +3; Str 17, Dex 12, Con –, Int –, Wis 10, Cha 1.

*Skills and Feats:* –; Toughness.

*Possessions:* Scale armor, cutlass.

## Areas of the Map

### (Area D7 – Deeper into the Labyrinth):

*The vertical tunnel opens up at the top into a 10 foot wide tunnel with an 8 foot high ceiling. Chains 5 feet long with sharpened edges dangle from the center of the ceiling every 10 feet, jangling slightly as you walk past. The floor here is clean, and there are no cobwebs on the walls or the chains.*

About 30 feet down the corridor on the left is a secret door. A Search check DC 35 will find it. It connects to the tunnel leading from the pit trap in room B5.

**Area E1 – A Tight Spot (EL 8):** This trap has two bypass switches. Both are on the east wall, before and after the trap. If the trap is triggered, consider the wights in area E2 warned.

**Crushing Wall Trap:** CR 8; mechanical; location trigger (pressure pad in middle of corridor); automatic reset (1 hour); hidden switch bypass (Search DC 25); walls move together (10d6, crush); multiple targets (all in 40 ft. section of corridor); never misses; onset delay (2 rounds); Reflex save DC 20 for half; Search DC 25; Disable Device DC 25.

### Area E2 – The Muster Hall (EL 12):

*This room is 35 feet by 65 feet, with a 10 foot high ceiling. Every 10 feet, a 7 foot long chain dangles from the ceiling, jangling slightly. There are 4 exits, one in the center of each wall, north, west, south, and east. Each looks identical, opening into a 10 foot wide, 8 foot high corridor. As you emerge from the darkness, you see the undead Marines you've grown accustomed to fighting arrayed in ranks in a semicircle around you, standing ready to fight. Behind them, the wights smile grimly and order the advance. As the zombies and skeletons rush forward, the chains hanging from the ceiling begin to writhe and stretch toward you...*

This is the mustering hall for all the undead troops. It's the closest thing they have to a home. When not on alert, the wights spend most of their time inspecting their troops and their equipment, and discussing tactics with each other.

The *darkness* trap is just inside the mouth of the corridor leading from E1, and is set to go off whenever a living creature passes. Grishnaz occasionally sets it off to test the reactions of the wights, or for a laugh. The *desecrate* trap has a similar setting, but is located in the center of the room and goes off whenever a living creature enters the room.

**Description:** This unit is even more spic-and-span than those stationed below. The wight officers take full advantage of being stationed next to the armory and

ensure that their troops are as close to spotless as it's possible for a bunch of decaying corpses to be.

**Tactics:** If the wights have been warned, either by the sound of the trap at E1 or by the remnants of an ambushed patrol, they arrange the troops in a semicircle around the entrance that they expect the incursion to come from. One of the elite wights goes to alert the chain devils in room E6 and another goes to retrieve the troops in E5. If the *darkness* trap goes off, then they attack each character as they emerge from the area of effect. The *desecrate* trap should be activated as soon as the characters enter the room, giving the troops the boost they need. If the chain devils are here, then they animate the chains hanging from the ceiling and aid in the attack. Both the elite wights and the regular wights join in the fray here. If the invaders have gotten this far, then there's nowhere to retreat to. Even in undeath, Imperial Marines do not surrender. The chain devils, on the other hand, flee the dungeon if the battle goes poorly.

**Darkness Trap:** CR 4; magic device; proximity trigger (*alarm* inside corridor from E1); automatic reset; spell effect (*darkness*, 10th level cleric); Search DC 27; Disable Device DC 27.

**Desecrate Trap:** CR 4; magic device; proximity trigger (*alarm* in center of room triggered by entry); automatic reset; spell effect (*desecrate*, 10th level cleric); Search DC 27; Disable Device DC 27.

**Elite Wights (3):** Medium Undead; CR 5; HD 8d12; hp 89, 75, 68; Init +3; Spd 30 ft.; AC 21, T 13, FF 18; Atk Slam +7 melee (1d6+3 plus energy drain) or longsword +7 melee (1d8+3/19-20/x2), grapple +7; SA Create spawn, energy drain; SQ Darkvision 60 ft., undead traits; AL LE; SV Fort +2, Ref +5, Will +7; Str 17, Dex 16, Con –, Int 12, Wis 12, Cha 17.

*Skills and Feats:* Hide +12, Listen +14, Move Silently +18, Spot +14; Alertness, Blind-Fight, Improved Natural Attack.

*Possessions:* Chain shirt, officer's sword, door key, set of dice.

**Wights (5):** Medium Undead; CR 3; HD 5d12; hp 54, 49, 42, 37, 38; Init +1; Spd 20 ft.; AC 19, T 11, FF 18; Atk Slam +3 melee (1d4+1 plus energy drain), grapple +3; SA Create spawn, energy drain; SQ Darkvision 60 ft., undead traits; AL LE; SV Fort +1, Ref +2, Will +5; Str 12, Dex 12, Con –, Int 11, Wis 12, Cha 15.

*Skills and Feats:* Hide +6, Listen +8, Move Silently +13, Spot +8; Alertness, Blind-Fight.

*Possessions:* Scale armor, door key.

**Human Marine Skeletons (12):** Medium Undead; CR 1; HD 1d12; hp 10, 9 (x3), 7 (x2), 6 (x3), 4 (x3); Init +7; Spd 20 ft.; AC 21, T 13, FF 18; Atk Cutlass +2 melee (1d6+2/18-20) or claw +2 melee (1d4+2), grapple +2; SA –; SQ Damage reduction 5/bludgeoning, darkvision 60 ft., immunity to cold, undead traits; AL NE; SV Fort +0, Ref +3, Will +2; Str 15, Dex 16, Con –, Int –, Wis 10, Cha 1.

*Skills and Feats:* –; Improved Initiative.

*Possessions:* Scale armor, cutlass, heavy steel shield.

**Human Marine Zombies (12):** Medium Undead; CR 1; HD 2d12; hp 23, 21 (x2), 17 (x2), 15, 13 (x3), 10, 8, 7; Init +1; Spd 20 ft.; AC 17, T 11, FF 16; Atk Cutlass +4 melee (1d6+3/18-20) or slam +4 melee (1d6+3), grapple +4; SA –; SQ Single actions only, damage reduction 5/slashing, darkvision 60 ft., undead traits; AL NE; SV Fort +0, Ref +1, Will +3; Str 17, Dex 12, Con –, Int –, Wis 10, Cha 1.

*Skills and Feats:* –; Toughness.

*Possessions:* Scale armor, cutlass.

### Area E3 – The Bone Room (EL 3):

*This room is 40 feet by 30 feet, with an 8 foot high ceiling. There are large piles of human bones against the walls, all picked clean and polished. In the center of the room is a 6 foot by 20 foot table, about 3 feet tall, and on the top are 4 human skeletons mostly assembled. At the end of the table is a large ceramic jar. As you enter the room, the piles of bones rattle as if something were emerging from them...*

This room has an iron bar door. It is the assembly room for the skeleton troopers. The bones are all carefully selected to create the best skeletons possible, with defective ones crushed into dust and burnt in the chain devils' forge. The ceramic jar contains 300 gp worth of small onyx gems, ranging from 25 gp to 50 gp in individual worth. The skeletons hidden in the piles are among the oldest in the complex.

**Description:** These skeletons have no equipment of any kind, and often end up with random bones from the piles they were concealed under entangled with their own. This can cause some confusion in attacking adventurers as they initially seem to be attacked by an animated tangle of bones rather than by an actual skeleton.

**Tactics:** The skeletons have been ordered to attack any living thing that enters the room.

**Human Marine Skeletons (4):** Medium Undead; CR 1; HD 1d12; hp 10, 9, 7, 5; Init +7; Spd 20 ft.; AC 15, T 13, FF 12; Atk Claw +2 melee (1d4+2), grapple +2; SA –; SQ Damage reduction 5/bludgeoning, darkvision 60 ft., immunity to cold, undead traits; AL NE; SV Fort +0, Ref +3, Will +2; Str 15, Dex 16, Con –, Int –, Wis 10, Cha 1.

*Skills and Feats:* –; Improved Initiative.

### Area E4 – Cold Storage Room (EL 3):

*The cold radiates from this 40 foot by 30 foot room, forming ice crystals on the iron bars of the door. The walls are covered with a brown furry coating that extends all the way up to the 8 foot high ceiling. Long tables line the walls, with 8 naked human corpses lying on them, preserved by the bitter cold. The tattoos on the bodies suggest that they were*

*sailors in life. Two more bodies sit on the edge of one of the tables. As you look into the room, their heads turn slowly in your direction...*

This room has an iron bar door. The walls are coated with brown mold, providing a perfect refrigeration system for storing bodies. These bodies are left from the last ship that stopped on the island to restore their provisions. The bodies all show wounds from claws and large, circular stab wounds. The zombies on the table were animated yesterday and are waiting to be dressed and equipped for duty.

**Description:** Just another couple of dead guys, sitting buck naked on a table in a refrigerated room.

**Tactics:** These zombies have no instructions yet, but will attack any living thing that enters because, well, that's what they do.

**Brown Mold (CR 2):** Brown mold feeds on warmth, drawing heat from anything around it. It normally comes in patches 2 to 3 feet in diameter, and the temperature is always cold in the area surrounding it. Living creatures within 5 feet of it take 3d6 points of cold nonlethal damage. Fire brought within 5 feet of the mold causes it to instantly double in size. Cold damage, such as from a *cone of cold*, instantly destroys it.

**Human Marine Zombies (2):** Medium Undead; CR 1; HD 2d12; hp 21, 17; Init +1; Spd 20 ft.; AC 13, T 11, FF 12; Atk Slam +4 melee (1d6+3), grapple +4; SA –; SQ Single actions only, damage reduction 5/slashing, darkvision 60 ft., undead traits; AL NE; SV Fort +0, Ref +1, Will +3; Str 17, Dex 12, Con –, Int –, Wis 10, Cha 1.

*Skills and Feats:* –; Toughness.

### Area E5 – Armory (EL 3):

*The sound of grinding metal echoes from this 30 foot square room. Inside, 3 zombies are sharpening cutlasses on grindstones, under the close supervision of a wight officer. The walls are lined with wooden stands holding armor and cutlasses.*

This room has an iron bar door. This is the armory. If the wight hasn't been alerted by the other officers, then it continues to have the zombies sharpen the cutlasses on the racks. The noise gives it a -4 penalty to Listen checks.

On the racks here there are 15 suits of Imperial issue scale armor, 3 chain shirts, and 23 Imperial Navy cutlasses. The gear is in good shape, if a bit rusty.

**Description:** More of the same.

**Tactics:** Once an enemy is sighted, the wight commands the troopers to attack, joining in freely and fighting to the death. After all, if the enemy is here, then they've already gone through everyone else who matters.

**Wight:** Medium Undead; CR 3; HD 5d12; hp 32; Init +1; Spd 20 ft.; AC 19, T 11, FF 18; Atk Slam +3 melee

(1d4+1 plus energy drain), grapple +3; SA Create spawn, energy drain; SQ Darkvision 60 ft., undead traits; AL LE; SV Fort +1, Ref +2, Will +5; Str 12, Dex 12, Con –, Int 11, Wis 12, Cha 15.

*Skills and Feats:* Hide +6, Listen +8, Move Silently +13, Spot +8; Alertness, Blind-Fight.

*Possession:* Scale armor.

**Human Marine Zombies (3):** Medium Undead; CR 1; HD 2d12; hp 23, 19, 14; Init +1; Spd 20 ft.; AC 17, T 11, FF 16; Atk Cutlass +4 melee (1d6+3/18-20) or slam +4 melee (1d6+3), grapple +4; SA –; SQ Single actions only, damage reduction 5/slashing, darkvision 60 ft., undead traits; AL NE; SV Fort +0, Ref +1, Will +3; Str 17, Dex 12, Con –, Int –, Wis 10, Cha 1.

*Skills and Feats:* –; Toughness.

*Possessions:* Scale armor, cutlass.

### Area E6 – The Forge (EL 9):

*This round, 50 foot wide room is dimly lit by the ever-burning fire pit in the center of the room. The fire pit is 10 feet wide. Tables line the walls, covered with gear works, tools, and scribbled-on sheets of paper. Long chains dangle from everywhere, the ceiling, the walls, and the floor alike. Hanging from 4 thin chains from the ceiling are 4 mummified dwarven heads, around the fire pit. Three strange figures stand within, resembling humans wrapped from head to toe in iron chains. One tinkers with an odd mechanism on a table, while the other two seem engaged in a lengthy debate about something. Suddenly they turn in your direction, and all the chains in the room begin to writhe like metal serpents...*

The chain devils are contract employees, signed up for a century of work here, maintaining and improving the traps. They enjoy their work here, and are considering signing up for another tour when this one's done in a few decades. If they haven't been warned by the wights, they are here, engaged in their usual activities. At the moment, one is repairing a broken gearwork from the spear trap in area C3, and the other two are discussing plans for a new trap. The noise gives them a -4 penalty to Listen checks.

The heads are those of the previous trap maintenance crew, who declined to work for Coyopultec when he took over the labyrinth.

**Description:** The pale skin visible beneath the tightly wrapped chains that gives these devils their name is marked with intricate black tattoos that seem to form a kind of language. Their glowing yellow eyes are strangely hypnotic.

**Tactics:** The chain devils immediately attack any living being they see here, animating the chains that surround them and concentrating on any characters wearing religious symbols or clerical regalia. They give no quarter and expect none. If the battle goes poorly, they flee, attempting to escape to the island above. There they'll wait for a passing ship to hijack and take to the main-



land where they'll seek a way home.

**Chain Devils (3):** Medium Outsider; CR 6; HD 8d8+16; hp 71, 62, 54; Init +6; Spd 30 ft.; AC 20, T 12, FF 18; Atk 2 chains +10 melee (2d4+2/19-20), grapple +10; SA Dancing chains, unnerving stare; SQ Damage reduction 5/silver or good, darkvision 60 ft., immunity to cold, regeneration 2, SR 18; AL LE; SV Fort +8, Ref +8, Will +6; Str 15, Dex 15, Con 15, Int 6, Wis 10, Cha 12.

*Skills and Feats:* Climb +13, Craft (blacksmithing-1/trapmaking-2) +17, Escape Artist +13, Intimidate +12, Listen +13, Spot +13, Use Rope +2 (+4 with bindings); Alertness, Improved Critical (chain), Improved Initiative.

**Area E7 – A Rolling Stone (EL 8):** This 50 foot long corridor ascends at a noticeable 20 degree angle to the north. The east wall, where the corridor turns the corner, is slightly damaged. A Spot check (DC 20) will notice the slight cracking from the last few times the boulder hit the wall. The bypass switch is on the west wall, 5 feet before the corridor turns west.

**Rolling Boulder Trap:** CR 8; mechanical; location trigger (pressure pad at end of corridor); manual reset; hidden switch bypass (Search DC 25); Atk +20 melee (6d6, huge boulder); multiple targets (all in 10 ft. by 40 ft. corridor); Reflex DC 25 for half; Search DC 30; Disable Device DC 28.

### Area E8 – The Long Fall (EL 8):

*This room is 20 feet square, with a ceiling 10 feet high. It seems you've reached a dead end, and the smooth stone walls mock your failure...*

There is a secret door hidden in the ceiling, and a hidden switch to open it on the west wall below. The Search DC is 29 for the switch, and 32 for the door itself. When the switch is pulled, the door opens down into the room, revealing an 8 foot wide tunnel leading up into the mountain rock. There are handholds carved into the inside of the door to enable the characters to reach the tunnel. Once in the tunnel, a ladder made of curved iron rungs embedded in the wall leads upward into the darkness. The tunnel is 100 feet high, and the ladder runs all the way up, to the edge of the room above.

The trap is triggered by the rung 20 feet from the top, which, depending on how fast the characters climb, may mean that one or two might reach the room above when their companions take the long fall. There's a hidden bypass switch halfway up the ladder on the right side of the tunnel that deactivates the trap. If the trap is triggered, all the rungs retract smoothly into the wall, but the noisy gears inside the walls give a 2 round warning to climbers still on the ladder. If the door below was left open, falling characters will plummet right through and splatter on the floor of the room below.

The round tunnel is such that any character of at least 6'3" in height can go spread-eagle, pushing against the walls with all four, and support himself that way – but he needs to be saved because he certainly can't get out of that position. Holding oneself up like this is easy at first (Strength DC 10), but the DC increases by 2 for each round the position is held.

**Retracting Ladder Trap:** CR 8; mechanical; touch trigger (rung 20 ft. from top); automatic reset (1 hour); hidden switch bypass (Search DC 25); 100 ft. drop from top (10d6, fall/adjust for distance up ladder); multiple targets (all targets on ladder); never-miss; onset delay (2 rounds); Search DC 25; Disable Device DC 25.

### Area E9 – Antechamber:

*This room is practically identical to the one below. There must be a similar catch somewhere on the walls...*

The secret door is on the north wall. The Search DC is 25 to find it. It opens into a 6 foot wide passageway that leads to the final encounter.

### Area E10 – Das Loot (EL 14):

*The narrow passageway opens into a 30 foot square room with a 20 foot high ceiling. The floor is covered with 2 feet of clear water, and through it you can see, in the center of the room, a 10 foot wide circular pit in the floor. Your light reflects off the metallic contents of the pit, dappling the walls with the reflected glitter of gold and silver coins. Here is the treasure you've struggled for! Though*

*there seems to be something else in the pit, buried under the treasure, perhaps the skeleton of some long-forgotten treasure hunter? And what luck! It seems that the chamber is guarded only by 4 armor-clad skeletons, posted in the corners of the room! This will be too easy...*

There is an *unhallow* spell affecting this room, with a linked *invisibility purge* spell targeting all beings who are not lawful evil.

The pit is 15 feet deep, and is nearly filled with coins. It also contains Coyopultec's body, abandoned there a century ago by Bloody Jack. Any character who has seen Coyopultec can make a Spot check (DC 20) to recognize the black-feathered cloak on the skeleton as the same one that Coyopultec wears.

The characters should be proud. No other group has made it this far before.

**Tactics:** Of course, it *is* all too easy. As the party enters the room, Coyopultec has sunk his incorporeal form into the floor, with only his head out of the stone, under the water. Grishnaz and the 2 bone devils are invisible and flying near the ceiling, the water elemental is concealed within the water itself, and Grishnaz's viper familiar is swimming in one of the far corners of the room.

Coyopultec lets the others take the brunt of the combat for a few rounds, while he sizes up the enemy with *detect magic*, and then summons a few monsters, probably fiendish giant wasps or crocodiles. The bone devils' first action is to block off any escape with a *wall of ice* in the corridor behind the characters, and then move in for hand to hand, concentrating on the strongest fighters. The water elemental targets spellcasters with its slam attack and then tries to grapple them and drag them under the water. Grishnaz tries to sneak attack any cleric he notices, and the skeletons charge in to soak up some hits.

If the fight is going well, then Coyopultec *blinds* one of the fighters so the bone devils can beat on her some more, while Grishnaz flies around near the ceiling, putting his *magic missile* wand to good use and casting *shocking grasp* through his familiar. The elemental keeps pounding the casters.

If the fight goes poorly, then Coyopultec uses his malevolence ability to possess the strongest fighter, turning her on her companions. The bone devils use their summon devil ability to get reinforcements, and Grishnaz heads for the exit. The elemental starts slamming any-one it can reach.

**Description:** Coyopultec still wears the religious emblem of his patron on his chest proudly. The slender priest has a stern look, his dark, hawk-like features creased with lines of bitterness. His cloak is made of black feathers, and his hands are never far from the hilt of his macuahuitl, *Lifetaker*.

Grishnaz has an overly clever look to him, as if he is

constantly repressing some cuttlingly clever remark. Slung over one shoulder is a small bag filled with his journals, and the contracts of his latest acquisitions. His skin is a dark red, and he takes pride in his polished horns and hooves. His familiar is almost always curled around his neck.

The bone devils look like the emaciated bodies of humans who died of some hideously skeleton-distorting disease. Their spines are so gnarled that the scorpion tails seem like a natural extension. Two rows of tiny horns extend from their eyebrow ridges back over their skulls to meet their spines. Their long needle-like teeth are set in a permanent predatory smile.

**Coyopultec, male human ghost Clr10:** CR 12; Size M (5' 7" tall); HD 10d12; hp 95; Init +1; Spd 30 ft., fly 30 ft. (perfect); AC 14, T 14, FF 13 (manifested) or AC 16, T 14, FF 15 (ethereal); Atk 2-handed macuahuitl +10/+5 melee (2d6+2/x3), grapple –; SA Rebuke undead (10/day), manifestation, corrupting gaze, malevolence, draining touch; SQ Undead traits, incorporeal traits, rejuvenation, turn resistance +4; AL LE; SV Fort +9, Ref +6, Will +11; Str 13, Dex 12, Con –, Int 10, Wis 16, Cha 17.

*Languages Spoken:* Common, Xulmec, Infernal.

*Skills and Feats:* Concentration +6, Diplomacy +8, Hide +9, Knowledge (Religion) +5, Listen +13, Search +8, Spellcraft +6, Spot +13; Alertness, Extra Turning, Improved Turning, Martial Weapon Proficiency (2-handed macuahuitl), Spell Focus (enchantment), Spell Focus (necromancy), Weapon Focus (2-handed macuahuitl).

*Possessions:* +1 2-handed macuahuitl of wounding, +2 studded leather, +2 cloak of resistance, holy symbol.

*Cleric Spells Prepared* (cast 6/5/5/4/3/2, save DC 13 + spell level): 0-level– *detect magic*, *guidance* (2), *cure minor wounds* (3); 1st-level– *bane*, *command*, *divine favor*, *obscuring mist*, *protection from good*; 2nd-level– *desecrate*, *enthrall*, *hold person*, *summon monster II* (2); 3rd-level– *bestow curse*, *blindness/deafness*, *deeper darkness*, *dispel magic*; 4th level– *poison*, *summon monster IV* (2); 5th-level– *greater command*, *summon monster V*.

*Domain Spells (Death and War):* 1st-level– *cause fear*; 2nd-level– *spiritual weapon*; 3rd-level– *animate dead*; 4th-level– *divine power*; 5th-level– *slay living*.

**Grishnaz, male imp Rog3/Sor3:** Tiny Outsider; CR 10; HD 6d8+3d6+3d4+12; hp 63; Init +5; Spd 20 ft., fly 50 ft. (perfect); AC 22, T 15, FF 17; Atk Sting +16 melee (1d4 plus poison), grapple +1; SA Poison, spell-like abilities (at will: *detect good*, *detect magic*, *invisibility* (self only); 1/day: *suggestion*), sneak attack +2d6, trapfinding, evasion, trap sense +1, familiar; SQ Alternate form (monstrous centipede, boar), damage reduction 5/good or silver, darkvision 60 ft., fast healing 2, immunity to poison, resistance to fire 5; AL LE; SV Fort +8, Ref +14, Will +9; Str 10, Dex 20, Con 12, Int 13, Wis 10, Cha 19.

*Skills and Feats:* Appraise +4, Bluff +16, Concentration +3, Diplomacy +16, Gather Information +8, Hide +24, Intimidate +7, Knowledge (arcana) +4, Knowledge (religion) +9, Listen +7, Move Silently +13,



Search +11, Sense Motive +8, Spellcraft +13, Spot +7, Survival +2 (+4 following tracks); Weapon Finesse.

*Possessions:* Angrabeg's Commanding Eye, wand of magic missile (as 5th, 32 charges).

*Sorcerer Spells Known* (cast 6/6, save DC 14 + spell level): 0-level— *acid splash*, *daze*, *message*, *read magic*, *touch of fatigue*; 1st-level— *charm person*, *comprehend languages*, *shocking grasp*.

**Sstac, Viper Familiar:** Tiny Animal; CR 1/3; HD 1/4 d8; hp 31; Init +3; Spd 15 ft., climb 15 ft., swim 15 ft.; AC 19, T 15, FF 16; Atk Bite +5 melee (1 plus poison), grapple -11; SA Poison, alertness, improved evasion, share spells, empathic link, deliver touch spells; SQ Scent; AL LE; SV Fort +2, Ref +5, Will +1; Str 4, Dex 17, Con 11, Int 7, Wis 12, Cha 2.

*Skills and Feats:* Balance +11, Climb +11, Hide +15, Listen +6, Spot +6, Swim +5; Weapon Finesse.

**Bone Devils (2):** Large Outsider; CR 9; HD 10d8+50; hp 105, 97; Init +9; Spd 40 ft.; AC 25, T 14, FF 20; Atk Bite +14 melee (1d8+5) and 2 claws +12 melee (1d4+2) and sting +12 melee (3d4+2 plus poison), grapple +19; SA Spell-like abilities (at will: *greater teleport* (self plus 50 pounds of objects only), *dimensional anchor*, *fly*, *invisibility* (self only), *major image* (DC 15), *wall of ice*), fear aura, poison, summon devil; SQ Damage reduction 10/good, darkvision 60 ft., immunity to fire and poison, resistance to acid 10 and cold 10, see in darkness, SR 21, telepathy 100 ft.; AL LE; SV Fort +12, Ref +12, Will +11; Str 21, Dex 21, Con 21, Int 14, Wis 14, Cha 14.

*Skills and Feats:* Bluff +15, Concentration +18, Diplomacy +6, Disguise +2 (+4 acting), Hide +14, Intimidate +17, Knowledge (arcana) +15, Listen +17, Move Silently +18, Search +15, Sense Motive +15, Spot +17, Survival +2 (+4 following tracks); Alertness, Improved Initiative, Iron Will, Multiattack.

**Huge Water Elemental:** Huge Elemental; CR 7; HD 16d8+80; hp 143; Init +4; Spd 30 ft., swim 120 ft.; AC 21, T 12, FF 17; Atk Slam +17 melee (2d10+7), grapple +27; SA Water mastery, drench, vortex; SQ Damage reduction 5/-, darkvision 60 ft., elemental traits; AL NE; SV Fort +15, Ref +9, Will +7; Str 24, Dex 18, Con 21, Int 6, Wis 11, Cha 11.

*Skills and Feats:* Listen +11, Spot +12; Alertness, Cleave, Great Cleave, Power Attack, Improved Bull Rush, Iron Will.

**Human Marine Skeletons (4):** Medium Undead; CR 1; HD 1d12; hp 8 (x2), 6 (x2); Init +7; Spd 20 ft.; AC 21, T

13, FF 18; Atk Cutlass +2 melee (1d6+2/18-20) or claw +2 melee (1d4+2), grapple +2; SA —; SQ Damage reduction 5/bludgeoning, darkvision 60 ft., immunity to cold, undead traits; AL NE; SV Fort +0, Ref +3, Will +2; Str 15, Dex 16, Con —, Int —, Wis 10, Cha 1.

*Skills and Feats:* —; Improved Initiative.

*Possessions:* Scale armor, cutlass, heavy steel shield.

## The Treasure: So, What Are We Going To Do With All This Stuff?

Inside the 10 foot wide and 15 foot deep pit in the center of the floor of E10 is the treasure that Jack Dascombe betrayed and killed so many people for. Or what's left of it. Dungeons filled with deathtraps and hideous monsters don't come cheap, y'know. Jack and Coyopultec ended up spending around a third of the loot of the dungeon, but what's left is by no means chump change.

There's nearly 111,000 gold pieces and slightly over 400,000 silver pieces in the pit, mixed together in one really heavy pile of cash worth about 150,000 in gold. The coins are all Imperial issue, silver nobles and gold royals, minted at least a century ago. In terms of volume, there are about 2 cubic feet of gold coins and 12 and a half of silver, weighing about 2,200 pounds and 8,000 pounds, respectively. That's a little over 5 tons of loose coins. The question now becomes, how does the party get this stuff out of here?

Most players never really think about how *heavy* solid coinage is. Much of the current modern financial system — checks, stocks, certificates, etc. — all came about to avoid the horrific inconvenience of lugging around literal tons of cash. You might be tempted to just avoid the issue and handwave getting the coins out of the dungeon, but I don't recommend it. Part of the balance for the crazy pile of loot here is the corresponding difficulty in actually using it. Killing to get the loot was just the beginning; now the players get to *earn* their money.

For those who are wondering, Bloody Jack just had the dwarves dig a tunnel straight to the chamber and filled it in after them, before building the labyrinth around the treasure. There's no trace of the tunnel left.

## I'll be Back!

Coyopultec, like most ghosts, is a bit harder to get rid of than an ordinary foe. His purpose drives him, and he cannot rest until he's achieved his revenge on Jack Dascombe. Unlike

### Angrabeg's Commanding Eye

This grotesque item looks like the eyeball of some large demonic creature. Nearly two inches wide, it has a red iris with a slit pupil, and continuously oozes thick greenish blood. When it's held in both bare hands, pointed at a living creature, and the name "Angrabeg" is uttered, the eye emits a red flash of light and that creature is affected by a *hold monster* spell, as if cast by a 10th level caster. The eye may be used three times per day, by a lawful evil being. This item takes up the same item slot as a glove or a pair of gauntlets.

Moderate enchantment; CL 10th; Craft Wondrous Item, *hold monster*; Price 75,600 gp; Weight 3 lb.

most ghosts, however, he's not linked to the remains of his body, but to the treasure that it's laid on for so long. Even after the group has destroyed his phantom body, so long as Coyopultec makes his level check (1d20 + 10 vs. a DC 16), he'll return in 2d4 days to haunt whoever holds the loot. Grishnaz knows this, and should the imp manage to escape, he'll be waiting for his employer to return. Coyopultec will probably wait for a while before striking at the thieves, spending his time observing them for weaknesses. Once he's ready to take back the treasure, his initial attack will probably involve a malevolence attack to possess the strongest fighter, and then Coyopultec will use his new pawn to kill the rest of the group and begin preparations to return the loot to the dungeon. There, he'll begin again, restocking the dungeon, and hiring new help, waiting for his old enemy to return.

It's conceivable that a *really* clever party might try to convince Coyopultec that the best revenge on Jack would be to let his treasure go out into the world and do good, thus releasing him from his ghostly fate. Such innovative thinking should be rewarded with bonus XP, GM kudos, and a really ludicrous Bluff or Diplomacy check DC, probably somewhere in the mid 30's or so. If they actually make it, well, good for them. There's always the Imperial taxman and Bloody Jack's seafaring revenant to get past. Don't worry, you'll get them yet, my pretty. And their little dog, too!

## The End of the Story

*The battle's over, and you and your companions are victorious. Standing over Bloody Jack's legendary treasure, you begin to realize exactly how rich you all are. The pit full of coins glitters in the light of your torches as you gather around and stare at it, hypnotized by the soft glow of precious metal.*

*Y'know, there sure is a LOT of it. It looks heavy, too. REAL heavy. Maybe you should just leave it here, and make this place into your treasure vault. Yeah, that would work. You could go back to the mainland, capture some monsters, bring them here and put them in the dungeon...maybe repair the traps...make this island into a really safe place to keep your precious loot. As long as you can all keep the secret, it should be fine. And you can all trust each other, right?*

*...Right?*

So, they've won. Yay them. Their reward lies before them; close to 150,000 gp in cash, Coyopultec's +1 2-handed macuahuitl of wounding, +2 studded leather, and +2 cloak of resistance and Grishnaz's Angrabeg's Commanding Eye

and *wand of magic missile*. Let's hope it makes up for the new enemies they've acquired. After all, they've wrecked a really useful scam run by some fairly powerful devils, who'll undoubtedly be looking for some payback. Also, any characters who've signed a contract with Grishnaz should be aware that, even if he's dead, the contract is still valid, and the signed contracts are not in his bag. All the paperwork in there is blank. Someone out there still has the lien on their soul, and will doubtless come calling some night. But cheer up! You're all rich now!

# Appendix 1: New Monsters

## BARRACUDA

### Small Animal

<b>Hit Dice:</b>	2d8+1 (11 hp)
<b>Initiative:</b>	+3
<b>Speed:</b>	Swim 60 ft. (12 squares)
<b>Armor Class:</b>	17 (+1 size, +3 Dex, +3 natural), touch 14, flat-footed 14
<b>Base Attack/Grapple:</b>	+1/-2
<b>Attack:</b>	Bite +4 melee (1d6+1)
<b>Full Attack:</b>	Bite +4 melee (1d6+1)
<b>Space/Reach:</b>	5 ft./5 ft.
<b>Saves:</b>	Fort +4, Ref +6, Will +1
<b>Abilities:</b>	Str 12, Dex 16, Con 13, Int 1, Wis 12, Cha 2
<b>Skills:</b>	Listen +5, Spot +5, Swim +9*
<b>Feats:</b>	Weapon Finesse
<b>Environment:</b>	Any aquatic
<b>Organization:</b>	Solitary, school (2-6), or pack (7-12)
<b>Challenge Rating:</b>	1/2
<b>Advancement:</b>	3-5 HD (Small); 6-9 HD (Medium)

Barracudas are renowned for their single-minded ferocity, attacking much larger creatures without hesitation. The statistics presented are for the common barracuda, which is about 4 feet long and weighs about 60 pounds.

### Combat

Barracudas rely on speed and savagery, using hit and run tactics to weaken their prey before swarming it in a frenzy.

**\*Skills:** A barracuda has a +8 racial bonus on any Swim check to perform some special action or avoid a hazard. It can always choose to take 10 on a Swim check, even if distracted or endangered. It can use the run action while swimming, provided it swims in a straight line.



# MORAY EEL

	<b>Moray Eel</b>	<b>Giant Moray Eel</b>
	<b>Small Animal</b>	<b>Large Animal</b>
<b>Hit Dice:</b>	1d8 (5 hp)	8d8+24 (57 hp)
<b>Initiative:</b>	+4	+6
<b>Speed:</b>	Swim 40 ft. (8 squares)	Swim 60 ft. (12 squares)
<b>Armor Class:</b>	16 (+1 size, +4 Dex, +1 natural), touch 15, flat-footed 12	17 (-1 size, +2 Dex, +6 natural), touch 11, flat-footed 15
<b>Base Attack/Grapple:</b>	+0/-3	+6/+16
<b>Attack:</b>	Bite +5 melee (1d4+1)	Bite +12 melee (2d6+7)
<b>Full Attack:</b>	Bite +5 melee (1d4+1)	Bite +12 melee (2d6+7)
<b>Space/Reach:</b>	5 ft./5 ft.	10 ft./5 ft.
<b>Special Attacks:</b>	Attach	Attach
<b>Saves:</b>	Fort +2, Ref +6, Will +1	Fort +9, Ref +8, Will +3
<b>Abilities:</b>	Str 13, Dex 19, Con 11, Int 2, Wis 12, Cha 2	Str 25, Dex 15, Con 17, Int 2, Wis 12, Cha 2
<b>Skills:</b>	Hide +9, Spot +6, Swim +9*	Hide +8, Spot +7, Swim +15*
<b>Feats:</b>	Weapon Finesse	Alertness, Improved Initiative, Power Attack
<b>Environment:</b>	Any aquatic	Any aquatic
<b>Organization:</b>	Solitary, school (2-8)	Solitary, school (2-8)
<b>Challenge Rating:</b>	1/2	5
<b>Advancement:</b>	2-4 HD (Small); 5-7 HD (Medium)	9-12 HD (Large); 13-16 HD (Huge)

Moray eels are famous for their dogged determination and irritability, latching onto intruders with their jagged teeth and refusing to let go until they are killed. The statistics presented are for the common moray eel, which is about 3 feet long and weighs about 35 pounds, and a size Large giant moray eel, which is about 10 feet long and weighs about 300 pounds. Stats for a Huge giant moray eel (with the fiendish template applied) are on page 14.

## Combat

Most morays find small crevices on the ocean floor to lurk in, darting out to strike at passing creatures.

**Attach (Ex):** If a moray eel hits with a bite attack, it uses its powerful jaws to latch onto the opponent's body and automatically deals bite damage each round it remains attached. An attached moray eel uses its flat-footed AC.

**Skills:** A moray eel has a +8 racial bonus on any Swim check to perform some special action or avoid a hazard. It can always choose to take 10 on a Swim check, even if distracted or endangered. It can use the run action while swimming, provided it swims in a straight line.

This printing of *Dungeon Crawl Classics #4: Bloody Jack's Gold* is done under version 1.0 of the Open Gaming License, version 5 of the D20 System Trademark License, version 4 of the D20 System Trademark Logo Guide, and the System Reference Document by permission from Wizards of the Coast, Inc. Subsequent printings will incorporate final versions of the license, guide and document.

**Designation of Product Identity:** The following items are hereby designated as Product Identity in accordance with Section 1(e) of the Open Game License, version 1.0: Any and all *Dungeon Crawl Classics* logos and identifying marks and trade dress; all proper nouns, capitalized terms, italicized terms, artwork, maps, symbols, depictions, and illustrations, except such elements that already appear in the System Reference Document.

**Designation of Open Content:** Subject to the Product Identity designation above, all NPC, creature, and trap statistic blocks are designated as Open Game Content, as well as all spell names, weapon statistics, and other elements that are derived from the System Reference Document.

Some of the portions of this book which are delineated OGC originate from the System Reference Document and are copyright © 1999, 2000 Wizards of the Coast, Inc. The remainder of these OGC portions of these books are hereby added to Open Game Content and, if so used, should bear the COPYRIGHT NOTICE "Dungeon Crawl Classics #4: Bloody Jack's Gold, by Joe Crow, Copyright 2004 Goodman Games (contact goodmangames@mindspring.com, or see www.goodman-games.com)".

*Dungeon Crawl Classics #4: Bloody Jack's Gold* is copyright © 2004 Goodman Games.

*Dungeons & Dragons* and *Wizards of the Coast* are Registered Trademarks of Wizards of the Coast, and are used with Permission. Open game content may only be used under and in the terms of the Open Game License.

*'d20 System' and the 'd20 System' logo are Trademarks owned by Wizards of the Coast and are used according*

*to the terms of the d20 System License version 1.0. A copy of this license can be found at [www.wizards.com](http://www.wizards.com).*

### OPEN GAME LICENSE Version 1.0a

The following text is the property of Wizards of the Coast, Inc. and is Copyright 2000 Wizards of the Coast, Inc ("Wizards"). All Rights Reserved.

1. Definitions: (a) "Contributors" means the copyright and/or trademark owners who have contributed Open Game Content; (b) "Derivative Material" means copyrighted material including derivative works and translations (including into other computer languages), potation, modification, correction, addition, extension, upgrade, improvement, compilation, abridgment or other form in which an existing work may be recast, transformed or adapted; (c) "Distribute" means to reproduce, license, rent, lease, sell, broadcast, publicly display, transmit or otherwise distribute; (d) "Open Game Content" means the game mechanic and includes the methods, procedures, processes and routines to the extent such content does not embody the Product Identity and is an enhancement over the prior art and any additional content clearly identified as Open Game Content by the Contributor, and means any work covered by this License, including translations and derivative works under copyright law, but specifically excludes Product Identity. (e) "Product Identity" means product and product line names, logos and identifying marks including trade dress; artifacts; creatures characters; stories, storylines, plots, thematic elements, dialogue, incidents, language, artwork, symbols, designs, depictions, likenesses, formats, poses, concepts, themes and graphic, photographic and other visual or audio representations; names and descriptions of characters, spells, enchantments, personalities, teams, personas, likenesses and special abilities; places, locations, environments, creatures, equipment, magical or supernatural abilities or effects, logos, symbols, or graphic designs; and any other trademark or registered trademark clearly identified as Product Identity by the owner of the Product Identity, and which specifically excludes the Open Game Content; (f) "Trademark" means the logos,

names, mark, sign, motto, designs that are used by a Contributor to identify itself or its products or the associated products contributed to the Open Game License by the Contributor (g) "Use", "Used" or "Using" means to use, Distribute, copy, edit, format, modify, translate and otherwise create Derivative Material of Open Game Content. (h) "You" or "Your" means the licensee in terms of this agreement.

2. The License: This License applies to any Open Game Content that contains a notice indicating that the Open Game Content may only be Used under and in terms of this License. You must affix such a notice to any Open Game Content that you Use. No terms may be added to or subtracted from this License except as described by the License itself. No other terms or conditions may be applied to any Open Game Content distributed using this License.

3. Offer and Acceptance: By Using the Open Game Content You indicate Your acceptance of the terms of this License.

4. Grant and Consideration: In consideration for agreeing to use this License, the Contributors grant You a perpetual, worldwide, royalty-free, non-exclusive license with the exact terms of this License to Use, the Open Game Content.

5. Representation of Authority to Contribute: If You are contributing original material as Open Game Content, You represent that Your Contributions are Your original creation and/or You have sufficient rights to grant the rights conveyed by this License.

6. Notice of License Copyright: You must update the COPYRIGHT NOTICE portion of this License to include the exact text of the COPYRIGHT NOTICE of any Open Game Content You are copying, modifying or distributing, and You must add the title, the copyright date, and the copyright holder's name to the COPYRIGHT NOTICE of any original Open Game Content you Distribute.

7. Use of Product Identity: You agree not to Use any Product Identity, including as an indication as to compatibility, except as expressly licensed in another, independent Agreement with the owner of each element of that Product Identity. You agree not to indicate compatibility or co-adaptability with any Trademark or Registered Trademark in conjunction with a work containing Open Game Content except as expressly licensed in another, independent Agreement with the owner of such Trademark or Registered Trademark. The

use of any Product Identity in Open Game Content does not constitute a challenge to the ownership of that Product Identity. The owner of any Product Identity used in Open Game Content shall retain all rights, title and interest in and to that Product Identity.

8. Identification: If you distribute Open Game Content You must clearly indicate which portions of the work that you are distributing are Open Game Content.

9. Updating the License: Wizards or its designated Agents may publish updated versions of this License. You may use any authorized version of this License to copy, modify and distribute any Open Game Content originally distributed under any version of this License.

10. Copy of this License: You MUST include a copy of this License with every copy of the Open Game Content You Distribute.

11. Use of Contributor Credits: You may not market or advertise the Open Game Content using the name of any Contributor unless You have written permission from the Contributor to do so.

12. Inability to Comply: If it is impossible for You to comply with any of the terms of this License with respect to some or all of the Open Game Content due to statute, judicial order, or governmental regulation then You may not Use any Open Game Material so affected.

13. Termination: This License will terminate automatically if You fail to comply with all terms herein and fail to cure such breach within 30 days of becoming aware of the breach. All sublicenses shall survive the termination of this License.

14. Reformation: If any provision of this License is held to be unenforceable, such provision shall be reformed only to the extent necessary to make it enforceable.

15. COPYRIGHT NOTICE  
**Open Game License v 1.0** Copyright 2000, Wizards of the Coast, Inc.

**System Rules Document** Copyright 2000 Wizards of the Coast, Inc.; Authors Jonathan Tweet, Monte Cook, Skip Williams, based on original material by E. Gary Gygax and Dave Arneson.

**Dungeon Crawl Classics #4: Bloody Jack's Gold** by Joe Crow, Copyright 2004 Goodman Games (contact goodmangames@mindspring.com, or see www.goodman-games.com).

Requires the use of the Dungeons & Dragons Player's Handbook, published by Wizards of the Coast, Inc. This product utilizes updated material from the v.3.5 revision.



This item is only one of the many popular role playing aids published by Goodman Games. Other role playing aids currently available or scheduled soon include:

Dungeon Crawl Classics #1: Idylls of the Rat King

Dungeon Crawl Classics #2: Lost Vault of Tsathzar Rho

Dungeon Crawl Classics #3: The Mysterious Tower

Dungeon Crawl Classics #5: Aerie of the Crow God

Monsters of the Boundless Blue: Wanderers Guild Guide to Aquatic Organisms

Monsters of the Endless Dark: Wanderers Guild Guide to Subterranean Organisms

Primeval Groves: The Wanderers Guild Guide to Dangerous and Unusual Plant Life

Beyond Monks: the Art of the Fight

Underdark Adventure Guide

Aerial Adventure Guide

Morningstar Campaign Setting

Complete Guide to Beholders

Complete Guide to Liches

Complete Guide to Drow

Complete Guide to Treants

Complete Guide to Wererats

Complete Guide to Doppelgangers

Dinosaurs That Never Were



[www.goodman-games.com](http://www.goodman-games.com)



**\$10.99** USA

SKU GMG5003