

KILLER of GIANTS

AN AMERICAN SURVIVAL GUIDE ADVENTURE
FOR 3+ LEVEL CHARACTERS

REQUIRES UX02: MIND GAMES PSIONIC RULES

COMPATIBLE WITH
DCC
RPG



KILLER OF GIANTS

AN AMERICAN SURVIVAL GUIDE ADVENTURE FOR 3+ LEVEL CHARACTERS

WRITING

Forrest Aguirre

ARTWORK

Cover and Interior artwork by Nate Marcel

LAYOUT

Matt Hildebrand

EDITING

Gilbert Isla and Reid San Filippo

MAPS

Thomas Gile

PLAYTESTING

Jeff Berenstein, Clint Bohaty, Christopher Chase, Nick Clawson, Paul Dundee, Thomas Gile, Stephanie Groen, Kevin Kenieczko, Jeremy Mahr, Eric Mielke, Jacob Nicolosi, Jason Raether, A.J. Suneson.

Visit us at <http://crawlingunderabrokenmoon.blogspot.com/>

or

On Google+ at: <https://plus.google.com/u/o/communities/109153580337571253836>

or

On Facebook: <https://www.facebook.com/ShieldofFaithStudios/>



Copyright © 2018 Shield of Faith Studios, LLC



This product is based on the Dungeon Crawl Classics Role Playing Game, published by Goodman Games. This product is published under license. Dungeon Crawl Classics and DCC RPG are trademarks of Goodman Games. All rights reserved. For additional information, visit www.goodman-games.com or contact info@goodman-games.com

TABLE OF CONTENTS

BACKGROUND	6	THE ELEPHANT CAGE	26
GM'S INTRODUCTION	7	THE DOG KENNEL	28
GUARD TOWERS	10	THE ARMORY	29
BASE WOODS	13	COMMUNICATIONS ARRAY	30
BLUE LAKE	13	TRANSPORTATION	31
LIVING QUARTERS	14	THE CRASHED SAUCER	33
RECREATION CENTER	14	THE KILLER OF GIANTS	38
BASE POOL	16	Complex 1	38
COMMISSARY	17	Complex 2	40
GYMNASIUM	20	Complex 3	43
BASE EXCHANGE	23	WANDERING MONSTERS	46
LIBRARY	26	AFTER THE ADVENTURE	47
		OGL	48

KILLER OF GIANTS



BACKGROUND

Of course, everyone knows about The Base. It's been there for ages. A few brave souls have traveled there to admire its eight towers, the high, unyielding fence topped with concertina wire, the perfectly-preserved buildings of the ancients. Like a snapshot of the past, frozen in time, a post-disaster anachronism. How is that possible, given the series of disasters that formed Umerica, that made it into the gnarled, chaotic mass it is today? Those who foolishly attempted to breach the fence soon found out, as raw electricity frazzled them through the bones, leaving only a sooty dark spot and maybe a pair of smoking boots where they once stood. The defenses of the ancients are formidable enough to thwart the most careful of thieves and the most enterprising so-called adventurers. No one has successfully entered this inner sanctum of the ancients.

Until now.

It has been several weeks, but only now have the rumors reached you. From the babble of lies and exaggerations, you gather this: Something fell from the sky. Something *big*. It crashed into the earth just outside The Base, and the previously-pristine defenses were compromised. The electrical force field that protected the base simply shut down. Some brave or stupid soul decided to try to cut their way through the fence — and succeeded!

Now, word has spread and seekers have gathered quickly. Some goods have already made their way out of this treasure trove and you, yes you, have the opportunity to grab your share.

But beware! The Base still has a few tricks up its automated sleeves. And others are already creeping their way through the complex. It's a winner-take-all free-for-all, and you can create your own ticket.

What awaits you there? Danger, of course, possibly death; but also a bevy of treasures, including the most coveted ancient treasure of all, the key to power, the means to rule the entirety of Umerica: The Killer of Giants!

Before the calamities that befell men, the mightiest among them held these objects; tall metal columns that contained the very power of the sun within their conical apex. These the ancients would hurl at one another, vying for dominance among the children of men. So destructive were these weapons that none could stand against them, not even the greatest and the mightiest. The rich and powerful alike quaked at their mere mention. Thus, they were dubbed "The Killer of Giants".

And now, they are there for the taking.

Move quickly!

GM'S INTRODUCTION

GM'S INTRODUCTION

Killer of Giants is a “point crawl” for Umerican Survival Guide characters levels 3 and up, though it can be run as a 0-level funnel or 1st level adventure if your goal is a near-instant Total Party Kill. An enterprising band of 2nd level adventurers might have just enough chutzpah to run away and survive with a limb or two intact. Maybe. But who am I to tell you about how to balance or not balance your game? The goal here is to have fun and you have to break eggs to make an omelette, right?

Not everything is explained. This is purposeful. Some of the unexplained elements allow the enterprising GM to riff off and take the party in different directions, potentially spawning a campaign arc. For example, where did the Vulpes get porcelain short swords? Who made them? Where? How? These are mysteries left to your imagination!

That said, here are some of the deep dark secrets that only you should know. Use these secrets in your ongoing campaign, as you like.

The base is an ancient Air Force missile base. The setup you see on the map and in the notes comes more or less from my experience being raised in the military. I lived on six different Air Force bases in eighteen years and got to know their layout pretty well. If you don't like the layout, mix it up! Just be sure that where elements connect, they make sense. It wouldn't make a lot of sense, for example, for the Commissary to be far removed from Living Quarters with the Death Bot in between — the Vulpes out on patrol wouldn't survive an inadvertent encounter with the Death Bot (not much will).

The flying saucer crash precipitated the depowering of a force field that was fed through the base's fence. Now the fence is just that — a metal chicken wire fence topped with barbed wire. Cut your way through at will.

The flying saucer crash caused much of the stranger facets of the base. The shadow attack encounter is a direct result of a reality-flux caused by the saucer crash. The floating astronaut in the tower? Same thing. If there's something weird that isn't explicitly related to a creature, robot, etc, it's probably because

of the reality-flux. If you want more ideas, go read the excellent book *Roadside Picnic* by Arkady and Boris Strugatsky. You could create an entire campaign based on that novel alone.

Various ranks are indicated here and there, usually in reference to Identification Cards. ID cards are the keys to getting where you need to go on a military base. In this case, access is defined by rank alone — not fully realistic, but neither are shadows that attack their casters. An “Airman grade” ID card belongs to someone of the rank Airman Basic, Airman, Airman First Class, or Senior Airman. “NCO grade” ID cards are: Staff Sergeant, Technical Sergeant, Master Sergeant, Senior Master Sergeant, or Chief Master Sergeant. All other ranks are officer ranks: 2nd Lieutenant, 1st Lieutenant, Captain, Major, Lieutenant Colonel, Colonel, Brigadier General, Major General, Lieutenant General, and General. Officers' ID cards can access anything that an NCO or Airman grade ID card can access. NCO cards can access anything an Airman grade can access. Note that a rank patch or medal is not the same as an ID card and is not sufficient identification to allow clearance to restricted areas, items, or commands.

While there are many varied encounters here, remember that though the adventuring party is here to loot, more or less, there is a bigger picture. There are nuclear weapons in the silos in various states of decay. One is perfectly preserved and, if the party is unlucky, they will inadvertently launch it. It might blow up as it hits the unopened silo door, it might explode just above the base, or it might nuke a nearby village or existing city ruins - all of these are possibilities. Though the players will understand the magnitude of this, their characters will not. You can build tension by introducing bits and pieces of folklore concerning the Killer of Giants with as much true or false data as you like, and from both trustworthy and untrustworthy sources. How much you reveal (and how much of it is true) is up to you, but I find that it is always a good idea, in a post-apocalyptic scenario, to have some extremely grave possibility hanging over their heads at all times. Take every opportunity to ask the players “do you really want to touch that button?”

They will.

GM'S INTRODUCTION



But you will have ratcheted up the tension in the meantime, which makes for a bit more intense, more fun, even funny, experience. Remember that horror and comedy are bedfellows. Strange ones, yes, but bedfellows nonetheless.

If the party does launch the weapon, intentionally or otherwise, are they willing to live with the consequences? I'm guessing that there is probably a bit of stigma attached to launching the very weapons that at least partially ruined the world in the first place. Even if nuclear weapons weren't "your" Great Cataclysm, remnants and scraps from old Hollywood will have given clear indications that nuclear weapons might have caused the Great Cataclysm. Does the party want anyone else to know they did this? Does one party member bear more of the blame for having launched the weapon than others? There are lots of opportunities for great roleplaying here!

And if they don't launch the weapon, that doesn't mean the threat isn't still there. Perhaps weeks or months after the party has moved on from the base,

they hear about a fiery mushroom cloud consuming [insert your party's home village here]. Then they have to deal with the knowledge that they didn't stop this from happening, though they might have had the chance.

Now this all sounds very grimdark. But it isn't meant to be. Embrace your darkest sense of humor. Most of the encounters here will allow for hilarity to ensue, and it will. There are several jabs at contemporary culture here that will make the most crinkled up sourpuss smile . . . right before he's blasted, laughing his fool head off, into a billion atomic particles. Have fun while you can!

— Forrest Aguirre

PS: Please note that you will need UX02: Mind Games in order to run encounters with psionic creatures. Believe me, it's worth the few shekels you'll pay for it! One of the best psionic systems in any game ever!

MAP OF THE BASE

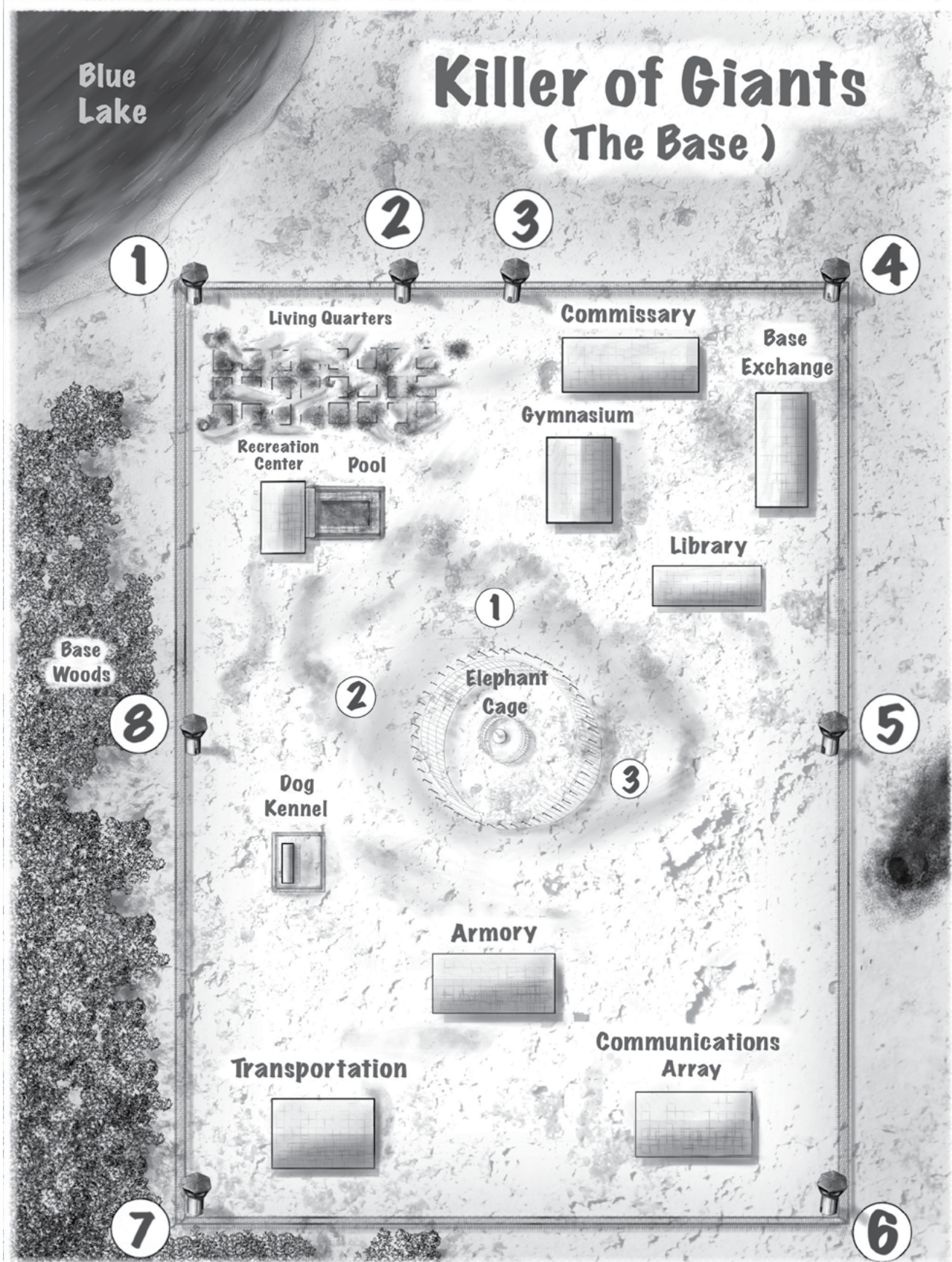

GUARD TOWERS

GUARD TOWERS

GENERAL:

Each of the 8 towers are built in exactly the same manner. They are cylindrical in shape, about 10' in diameter, with a steep spiral staircase approximately 30' high leading up through an opening into an observation tower. The observation deck is 15' in diameter with 10' ceilings. The entire circumference of the deck has bullet-proof glass windows set from eye-level to the roof, allowing a clear 365° view of surrounding areas.

TOWERS 1-3:

These towers have been taken by a recently-arrived Vulpes den to guard their newfound residence at the living quarters. The sentries here have keen eyesight, as one would expect from mutant foxes, but do not seem to care much about events happening at a distance, so long as their egress from the living quarters to the commissary and back remain unobstructed. They seem to have no interest in the other buildings as of yet, but will sally forth from the towers to intervene if they see strangers entering the living quarters or the area leading from the living quarters to the commissary. Sentries are armed with crossbows and porcelain short swords, while sergeants are armed with longbows and metal hand axes. Each tower is manned by four sentries and one sergeant. [**Vulpes:** INIT +3; ATK Bite +2 Melee (1d4) or by weapon; AC: 13; Armor Die: [1d3]; HD 2d8; HP: 9 ea; MV 40'; ACT 1d20; SP: Never surprised; SV Fort 0, Ref +3, Will 0]. [**Vulpes Sergeant:** INIT +3; ATK Bite +2 Melee (1d4) or by weapon; AC: 13; Armor Die: [1d3]; HD 2d8; HP: 12 ea; MV 40'; ACT 1d20; SP: Never surprised; SV Fort 0, Ref +3, Will 0; AL N].

TOWER 4:

The spiral stairway of this tower seems to be completely empty. A single cockroach hides beneath the stairs, though only those with extraordinary means of detection (a life-form scanner, telepathy, etc.) will know of its presence. Those who ascend the stairs quickly realize the horrifying truth as they open the entry hatch to a room full of a dozen bodies and even more body parts, all riddled with bore



holes: the bug downstairs is no common vermin. It is a dreaded Shockroach!

This Shockroach has plenty of meat in its storehouse upstairs, so it won't attack unless provoked. But if threatened in the slightest manner, it will shock all within its area of effect. If there are bodies left behind or, in the case of a Total Party Kill, the Shockroach will begin the tedious process of slowly levitating the dead bodies up into its storehouse.

[**Shockroach:** INIT +4; ATK Special; AC: 19; Armor die: nil; HD: 1 HP; MV 40'; ACT: 1d24; SP: Electric Shock for 3d10 damage, 20' radius, 3x/day or make DC 18 Fort SV for ½ damage. Immune to electricity and radiation; SV: Fort +10, Ref +6, Will +10, AL N. It has limited telekinesis, which allows it to drag objects — usually dead bodies, let's be honest — as if by a person with 18 STR with a range of 40'. Note that this telekinesis only allows the ability to slowly drag objects, not the ability to throw them or move them with any great speed. After all, it's just a cockroach. .. right?]

TOWER 5:

The bottom of this tower is empty. Those looking through the opening at the top of the stairs will see several objects floating suspended in the air: a human skeleton wearing an astronaut suit and helmet, a dozen ink pens, a burning wax candle, a metal candle-holder, several matches, and a small notebook. The skull of the skeleton is encrusted with cheap faux plastic gems.

GUARD TOWERS

Those who enter this level also experience zero-gravity in the confines of this section of the tower. Once an object in this area is set in motion, it does not stop until it hits another object or window. The skeleton may be removed from the spacesuit, which is fully-function. It has enough air for 6 hours of survival in total vacuum. If any of the suit's components are separated from the rest, the remainder will not protect the wearer from vacuum. The components provide armor protection as follows: Suit: 1, helmet: 2, gloves: 1 ablative, boots 1 ablative (see the *Umerican Survival Guide*, New Armor Rules for an explanation of how these armor pieces function). There is a small patch of a yellow smiley face sewn into the left breast of the suit.

The notebook contains a hand-written ledger (in black ink) recording the comings and goings of crew members aboard a spaceship dubbed "Horizon Event". The front cover features a filled-in black star, under which the initials "M.T." are written.



TOWER 6:

One of the windows on the control room of this tower is broken. This has allowed a massive flock of

Battories to roost. At some point, someone recently tried to affix a wooden plank barricade to the opening between the hatch and control room to prevent the Battories' egress, but was unsuccessful. During the day, they remain in the tower unless someone tries to enter the broken upper window with a light source. If someone does enter the upper level with a light source, the Battories swarm the light source until the light is extinguished. Fighting the flock is no small matter. Each Battorie produces a tiny electric shot, but when combined, their numbers are deadly. If attacking the brood, one point of damage equals one dead Battorie. Killing off the cloud of mutant bats is a near-impossible task. There are 500 Battories in the tower. If reduced to 100 or fewer in number, the flock leaves the tower to seek a roost elsewhere. Important safety tip: douse your light or be doused! The only other thing in the tower is a thick coating of guano.

[**Battorie:** INIT +2; ATK SP; AC 12; Armor die: 1d3; HD: 1 HP; MV 30' flying; ACT 1d20 per 10 Battories; SP: Electric shock – each group of 10 Battories can produce 1d3 points of electrical damage. DC 12 Fort save for ½ damage. SV: Fort 0, Ref +2, Will 0, AL N]

TOWER 7:

This tower is not a tower at all! This tower is actually a flimsy metal façade housing a Deathbot sentry! It has been keeping its beady electric eye on the Giant Mosquito in the Base Woods, assessing its strengths and weaknesses and trying to determine if the gargantuan insect means to attack the base (so long as food is plentiful in the woods, it won't, but the Deathbot doesn't know that). If someone tries to enter this "tower," the Deathbot takes this as a security threat and literally steps out of the tower, the control room splitting and splintering to reveal a 30' tall remorseless killing machine.

[**Deathbot:** INIT +10; ATK: Death Ray +16 ranged (DC 12 Fort save or die); flamethrower +16 ranged (10' long, 15' wide cone of fire: 3d6 + DC 22 Ref save or catch fire); buzz-saw arm +16 melee (ref save vs attack roll or be grabbed, STR vs 22 STR to get free, grabbers emit freezing cold every round for 2d6 damage; AC 20; Armor die: [1d10]; HD: 12d12; HP: 90; MV 40'; Act: 4d20; SP: Wizard Brain, spells; SV: Fort +14, Ref +10, Will +12, AL L]

GUARD TOWERS

The Wizard Brain housed in the Deathbot can only wrest control of the systems intermittently. On any turn, roll 1d12. On a result of 10-12, the Wizard Brain is in control and can override the Deathbot's primary programming (which is, in order of importance to the Deathbot: 1) Watch that Giant Mosquito, 2) Attack anyone who touches the tower, and 3) protect the base from threats). Keep in mind that the Wizard Brain might fully agree with the Deathbot's chosen course of action in a given round and cede control back to the Deathbot's systems. Spells may only be cast on a turn where the Wizard Brain is in control. The wizard's main objectives are: 1) Convince others to become his followers/slaves, 2) Attack anyone who touches the tower, and 3) protect the base's precious ancient artifacts from threats.

Characters who flash ID badges of any rank might give themselves a few more moments to live. If the Wizard Brain is currently in control, there is no effect. But if the Deathbot is in control, it will turn from the party and set off to attack the Giant Mosquito. Keep in mind, though, that if the Wizard Brain gains control next turn, the Deathbot will turn right around and hunt for the characters again.

If the party is able to hide indoors without being spotted, and the Deathbot is "dominant", it will set off after the Giant Mosquito, as outlined above. If the Wizard Brain is dominant, it will attempt to use ESP to find the party. Note that this requires that the Wizard Brain have a physical memento (scrap of hair, etc) of one of the PCs and must make the requisite spell check in order to detect the party member. The Deathbot's actions will appear erratic as the struggle continues between the Wizard Brain (who wants to either enslave or kill the party members) and the Deathbot (who wants to kill the Giant Mosquito, now that the Deathbot's cover is blown). This struggle will only stop when either the Deathbot engages the Giant Mosquito or the Wizard Brain has enslaved or killed the party members.

The Wizard Brain can cast the following spells with a Casting die and bonus of 1d20+8:

1st: *Charm Person, Sleep*

2nd: *Scare, ESP*

3rd: *Haste, Dispel Magic*

TOWER 8:

Three Mandroids may or may not be present in the control room of this tower. Roll 1d6: On a 1-5 they are in the tower. On a 6, they will be encountered outside the tower, but nearby, likely repairing breaches in the base fencing. They appear as normal humans, but with silver eyes and exaggerated stiffness to their movements, which appears very unnatural. If they encounter the party, the Mandroids will demand to see identification. If the party cannot present a base ID card or other satisfactory military identification, the Mandroids will proceed to arrest them, handcuff them, and take them up to the tower (unless they are already there) and await "instructions from HQ". A similarly-manacled skeleton in the control tower indicates that such instructions will never come. Note that the Mandroids will never attack with lethal force, seeking only to subdue "suspects".

[**Mandroids:** INIT: +3; ATK: Subdual Martial Arts +3 melee (1d4+3 subdual damage only); internal taser (1d6 subdual damage plus make a DC 18 Fort save or pass out for 1d4 turns); AC: 13; Armor die: [1d8]; HD: 4d10; HP: 26 each; MV 30'; Act: 1d20; SP: Infravision 60', immune to mind-altering spells, heal 3 HP per turn; SV: Fort +5, Ref +3, Will +6, AL:N]

BASE WOODS

The Base Woods are a thick tangle of mixed deciduous and evergreen trees, with a floor covering of ferns. Movement in the forest is slowed to half for those on foot because of the prolific branches and the snagging undergrowth. It is impossible to hover or fly through the trees, but it is possible to fly above their tops, some 60' up. Those passing over the top will soon regret their decision, however, as a Giant Mosquito buzzes atop the trees. This fearsome insect is larger than many houses — 100' from tip to tail — and its buzzing has a hypnotic effect on all those within the hearing distance of 200'. Those in the affected area who do not stop their ears must make a DC 10 Will save or be transfixed to the spot they are standing on by the sound of the creature's wings. They are completely frozen for 1d3 rounds or until attacked or slapped by allies. This effect will cause those flying above the trees to lose concentration and possibly come crashing through the trees to the ground. This might be preferable, as the abomination suffers a -10 penalty when trying to attack through the trees. Its proboscis is plenty long to reach to the forest floor, but it has a difficult time aiming with all the brush.

But falling through the trees or, indeed, causing any loud noise in the woods forces a 1-in-6 chance that the forest's resident Cerebear will investigate. And it will not be inclined to hospitality!

[**Giant Mosquito:** INIT: 0; ATK: Proboscis +8 melee (1d12+6 + drain 1d3 STR/rd, crits on an 18-20) and kick +4 melee (1d6); AC: 10; Armor die: 1d8; HD: 8d8+10; HP: 52; MV 40'/70' flying; Act: 2d20; SP: hypnotic drone, proboscis crits on 18-20, STR drain of 1d3/rd on successful proboscis hit; SV: Fort +8, Ref 0, Will +2, AL: N]

[**Cerebear:** INIT: +2; ATK: Bite +7 melee (1d8+4) or claws +7 melee (1d6+4); AC: 11; Armor die: 1d6; HD: 5d8; HP: 31; MV 40'; Act: 2d20; SP: Abhorrent Visage, 720° vision, hug, psion powers, play dumb; SV: Fort +5, Ref +1, Will +10; AL: N. This Cerebear has the following psionic powers: Hypercognition, Distraction, Force Shield, Thought Tap, Kinetic burst, Vertigo. Psychokinesis & Telepathy focus die of 1d4. It also has an active Psy-Bauble floating amongst its eyes. This is a meteoric iron blob carved with crude stars that grants a +2 to all saving throws when active.]

BLUE LAKE

This lake provides a good livelihood for a small village on the far shore. Mostly, this is an innocuous lake, 80' deep at its deepest point, full of healthy fish and clean water.

If the water is disturbed by any loud explosion or the introduction of pollutants (including radiation, garbage, chemicals, etc.), there is a 4-in-6 chance that a group of 6d4 Salmen will come to investigate. If they catch the perpetrators of the disturbance in the act or determine the guilty party from available evidence and inference, they will attempt to drive the miscreants away from their home using their telekinetic powers and brute force. They will not stop until their opponents have backed away from the shore a full 100'. They will then fan out to create a cordon to prevent the intruders from returning. Though small (they stand about 4' tall), they are persistent and tough. They are armed with driftwood clubs lined with sharpened gar teeth, which act as swords.

[**Salmen:** INIT: 0; ATK: Gar tooth sword +2 melee (1d8+2); AC: 15; HD: 3d8; HP: 15 each; MV 30'/60' swimming; Act: 1d20; SP: Telekinesis, scales reflect all beam weapon attacks; SV: Fort +4, Ref 0, Will +12; AL: N. Salmen have a Psychokinesis Focus Die of d6 each and may use Remote Hands and Remote Grapple. These are their only psionic powers. If an attack with a beam weapon successfully hits one of them, the beam is reflected back at the shooter. The shooter must make a DC 10 Luck check to avoid being hit by the return beam. The Salmen suffers no damage from beam weapons.]

LIVING QUARTERS + RECREATION CENTER

LIVING QUARTERS

This area was, until very recently, composed of 36 orderly buildings set in six neat rows of six. That is, until the Vulpes decided to move in. While the buildings still stand, a complex series of dens, tunnels, and trenches have been dug into the ground beneath them, allowing the Vulpes easy and unseen access to and from their buildings. Anyone entering this area will quickly learn that this is no haphazard demolition project, but a well-planned construction that allows the Vulpes a highly-effective defense. Any person entering the area will see eyes darting in and out of holes, around buildings, through windows, and over rooftops. In addition to the guards stationed at Towers 1-3, there are 40 adult Vulpes of fighting age and a further 30 pups scattered throughout the living quarters. If the party simply passes through, the Vulpes will keep a careful eye on the strangers, but will let them through. Should a party member attempt to talk with the Vulpes, the mutant foxes will not answer. If the party should attack any of the Vulpes or attempt to enter one of their scores of ground holes (beneath which the pups are kept), the Vulpes will defend themselves with great ferocity. Two detachments of guards from Towers 1-3 will also run to the den's aid. The complexity of the tunnel-and-trench system is such that on any given round, one randomly-determined party member will be subject to a backstab attack (+0; d10 on Crit Table II). All Vulpes except the guards use fire-hardened wooden stakes for 1d3 damage. Because of their small size, up to 4 Vulpes can engage any one human-sized foe at a time. Those foolish enough to actually enter their underground tunnels are subject to two such backstab attempts each round.

[**Vulpes:** INIT: +3; ATK: Bite +2 melee (1d4) or by weapon; AC: 13; Armor die: 1d3; HD: 2d8; HP: 9 each; MV 40'; Act: 1d20; SP: Never surprised, 1 backstab (+0, 1d10 on Crit Table II) per round, per den, if in lair; SV: Fort 0, Ref +3; Will 0, AL: L]

RECREATION CENTER

1. A waist-high, gated wooden bannister separates this area from the rest of the entryway. The ceilings in this front area are 10' high. Everything in here is pristine, save for a thin layer of undisturbed dust and a few small cobwebs in the upper corners of the room inhabited by a few spiders (which are "normal" unmutated spiders, but which will probably terrify a band of paranoid adventurers, as they should). A chair and locked desk sit facing the bannister. Opening the lock requires a DC 10 check, or the desk can simply be splintered to get at the contents. Inside the desk are:

- 1 key to area 11

- 1 stapler

- 50 staples

- 50 sticky notes (still sticky)

- 1 wooden graphite pencil, sharpened

- 20 paper clips

- 1 manila envelope containing: 3 photocopies of military IDs for Airman Greta Hornsby (Airman), Staff Sergeant Hamlet deSantillana (NCO), and Master Sergeant Graemer Ellison (NCO)

- 1 small clear plastic box containing 10 spearmint mints (still minty-fresh!)

- There are several other empty cabinets, as well.

2. Restrooms, men's and women's. The water still flows enough that up to 10 wineskins can be filled with the precious liquid before it becomes toxic due to rust and sludge in the lines. Any water from here that is consumed beyond the 10 wineskins forces a DC 20 Fort save to avoid slow, agonizing death over 1d4 hours. Those who do not die suffer a permanent 1d3 STA loss for each wineskin consumed. The save must be remade for each wineskin beyond the 10th that is consumed. There are just a few sheets of TP left on a roll in each room.

3. The ceiling in this room (which encompasses this area and areas 6 and 7) are 20' high. Here, soft fake leather chairs surround low wooden tables. There is dried gum stuck under the tables in various spots. It's rock hard and has mostly lost its flavor. A strange

RECREATION CENTER

RECREATION CENTER

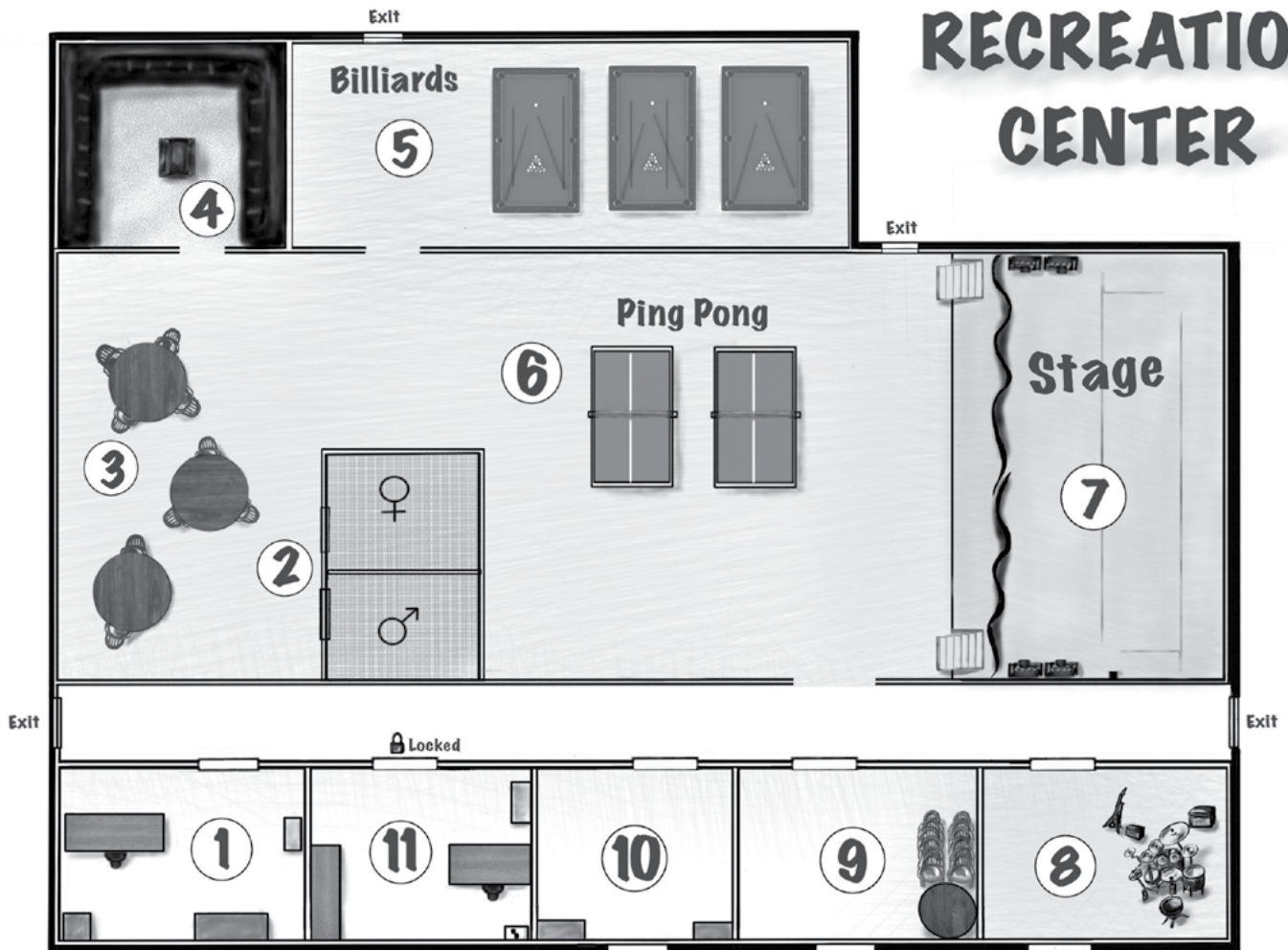

book entitled *Make Lovecraft, Not Warcraft* sits on the table. Inside are 24 pages of brightly-colored art depicting strange tentacled, amorphous creatures, usually in the act of eating humans.

4. A fake leather sofa takes up three entire walls of this dark, windowless room. It feels much more squat than its 12' high ceiling would indicate. A feeble green light shines from a small, black, conical object set in the middle of the floor. If this object is touched, a three-dimensional hologram of a slender woman in a white dress appears.

"I am Reese," the woman states. "We have a wide selection of entertainment available for you!" she says with a smile. "Please select from the following options: for action and adventure, say 'one'; for drama, say 'two'; for comedy, say 'three'; for science fiction and fantasy, say 'four'; for documentary,

say 'five'; for international cinema, say 'six'; for romance, say 'seven'; for western, say 'eight'; for anime and cartoons, say 'nine'; for children's shows, say 'ten'."

Once a selection is made, she says "Great! Thank you! Now state the title of the movie or show you would like to see, then sit back and enjoy your popcorn!"

If the party makes up a title, Reese states: "I'm sorry, that movie or show doesn't exist yet. Please try again." If the party states the title of a real-world movie or TV show, Reese states: "Hold on while I retrieve that for you." After one minute, she states "Retrieving data." She repeats this every 30 seconds for infinity. (Judge hint: set a timer and repeat the phrase every 30 seconds in real time until the players either destroy Reese or you).

RECREATION CENTER + BASE POOL

5. Three billiard tables are evenly spaced through this room. All the billiard balls, racks, and three cues for each table are present and in perfect condition. A pack of unopened cigarettes and a disposable lighter (20 uses left) are on one table. Another has a metal flask on it. The flask is empty. A trash can in the corner contains two empty beer bottles labeled “Rickenbockers Pale Dry Dark Hoppy Honey Sweet Bitter Mead Ale”.
6. A ping-pong table is set up in the middle of the floor. There are four paddles and three ping pong balls on it.
7. A red velvet curtain hangs down to the top of a raised stage that sits three feet off the ground. Two steps lead up from the main floor to the stage on either side. Behind the curtain is a fire extinguisher with two shots of flame-retardant powder still in it. Each shot will extinguish a small, campfire-size blaze or temporarily suppress the same area of a larger fire. The stage lighting and mechanical boxes on the walls have electrical shorts in them. If they are turned on, the character flipping the switch must make a Luck check, rolling under their Luck on a d20, or a fire begins.
8. A full drum set, a pair of drumsticks, a flying-V guitar, several guitar picks, and an amplifier are in this room. The guitar is in tune and the amplifier is powered by an internal power cell that will allow 2-24 hours worth of playing.
9. A small metal tin labeled “Dr. Krayder’s Psychedelic Mystery Putty” sits on the floor of this room. Inside the can is a pliable putty that scintillates with the colors of the rainbow. A small, spherical magnet the size of a large marble is buried in the putty. The putty is magnetic and will very slowly wrap around and “swallow” the magnetic ball.
10. A stack of 12 red plastic cups, 20 blue waxed paper plates, and a box of 12 white plastic sporks sit near the outside door of this otherwise empty (but carpeted) room.
11. The door to this room is locked. The key from area 1 will open the lock, or a successful DC 15 lock-picking check will allow access. The door may be smashed down, but it is very tough and will require several very noisy rounds to break through. There is a 3-in-6 chance of attracting a random wandering monster if the door is forcibly

broken. Inside the carpeted room is a chair, desk, bookshelf, and locked safe. The desk is unlocked and contains the following:

- 20 paper clips
- 3 wooden graphite pencils, unsharpened
- 1 military ID for 2nd Lieutenant Jonathan Luhrs
- 1 electromagnetic swipe card labeled “Recreation and Mechanicals”
- 1 clear plastic box containing 15 orange pill-shaped candies (still citrusy fresh!)
- 1 paperback book entitled *World War IV* by Sir MacAlesteir Nimrod Dollup Jr.
- The safe requires a DC 17 lock pick check or explosives to open. It contains:
 - 1 sawed-off shotgun, double barreled
 - 8 rounds of shotgun ammunition
 - 3 yellow, cream-filled snack cakes. A little stale, but still good.

BASE POOL

This outdoor pool looks clean and well-kept. The white tile is sparkling clean. The water is clear, the scent of chlorine assures the absence of germs, and a robotic lifeguard attends the front gate, playing ancient earth beach music from a speaker in its chest. The guard cheerily greets visitors, who are invited to swim for free!

“In fact,” the lifeguard says, “there are already swimmers in the pool right now!”

On looking into the pool, the party will see what appear to be a dozen extremely prune-skinned bodies floating near the bottom of the pool. They all have a blue tint to their skin. They are dressed in various kinds of clothing, some contemporary, some ancient. The twelve bodies look to be long dead, but those who watch closely will eventually see some eyes flutter and blink open. They will then arise out of the water, floating up to the surface, then up into the air! Each of these creatures, once human, is now horribly shriveled. It does not take long to realize that they are living, waterlogged Skin Bags, devoid of bones or internal organs!

If the party decides to engage in combat with these horrifying corpses, they will find them easy to hit.

BASE POOL + COMMISSARY

But should one of the corpses be cut with an edged weapon of any kind, the true terror begins to unfold — literally!

When a Skin Bag is cut, the creature tears itself open and envelops its opponent in its skin. The enwrapped victim may attempt a DC 12 Strength check to remove the unwanted body glove. Should the check fail, however, the victim must make a further DC 10 Will check to avoid passing out from sheer terror as they are enfolded inside the erstwhile-human's soggy skin. Should this happen, the hapless victim will drown in 5 rounds unless freed with outside assistance. Once freed, the victim may breathe, but movement and attacks are halved for 1d4 rounds.

Freeing the victim requires cutting away the enveloping skin bag. This inevitably results in 1d4 hit points of damage to the trapped victim, even with the most careful incisions, as the Skin Bag will flail and twist in an effort to avoid being cut. Once the Skin Bag has been cut for 5 points of damage, it collapses to the ground as a pile of skin.

If the Skin Bag kills its victim, the victim's bones and organs slough out underneath them and the victim, in turn, becomes a Skin Bag that will quickly attack the nearest non-Skin Bag being.

[**Skin Bag:** INIT: -2; Atk: Envelop +0 melee; AC: 10; Armor die: nil; HD: 5 HP; MV: 30', swim 30'; Act: 1d20; SP: Enveloping attack. Considered 1 HD undead for purposes of turning; SV: Fort 0, Ref 0, Will +3; AL: C]

COMMISSARY

1. A **huge** (40' long) Tri-eye-dra lives in this locked semi-trailer. It enters and exits (to hunt!) via a 3' wide hole in the trailer's bottom. During the day, it sleeps; at night, it hunts — unless it is disturbed during the day, in which case . . . it hunts!

[**Tri-eye-dra:** INIT: +4 (night), -1 (day); Atk: Bite +6 melee (3d4+3), constrict +0 melee (1d6 the 1st round, then move up the die chain: 1d7, then 1d8, then 1d10, then 1d12, etc. each round), three-eyed laser blast +0 ranged (1d6; 80/160/240); AC: 14; Armor die: [1d4]; HD: 7d10; HP: 42; MV: 40', swim 20'; Act: 2d20; SV: Fort +2, Ref +4, Will 0; AL: N]

2. This trailer is locked with a rusty padlock which can be opened by one sharp blow. Inside, perfectly preserved, are the following:

- 4 cases of cheesy whizzer fake cheese spray

- 1 case of 12 tins of saltine crackers

- 15 cases of 12-pack toilet paper rolls, wrapped in plastic

- 1 case of 100 rubber gloves, size medium

- 10 cases of 1000 cotton balls, bagged in plastic bags of 100 each

- 3 flashlights, shake to light (dim, but usable. Note that shaking makes a lot of noise!)

- 10 cases powdered milk, each case makes 10 gallons of milk

- 10 cases of 6; 5-lb flour bags (white bleached)

- 50 cases of 10 cartons of 10 packs of cigarettes (20 cigarettes in a pack) (Canc-o-rama brand)

3. A forklift, with no "charge" left in it sits near one of the dock doors. The keys are in the ignition and it will function if charged with electricity. None of the outlets in this building provide electricity, however, so some other means of charging it will need to be found.

[**Forklift:** INIT 0; Atk: rundown +1 melee (1d8+damage bonus); AC: 10; Armor die: [1d5]; HD: d4; Speed Cruise 1; Act: 1d20; SV: Fort +2, Ref 0, Will NA; Traits: Open, Dangerous]

Once fully charged, the forklift will last for 4 hours before needing a recharge. Note that the controls on a forklift are not as intuitive as those for other vehicles. Petrolheads get the automatic 1d20 action die, while untrained non-petrolheads get 1d12 until they have trained for a number of hours equal to 20 minus their intelligence. The hydraulic lift can lift anything up to the size and weight of a small car up to 40' in the air.

4. The small doors leading to the outside stairs are unlocked. The large doors leading to the main grocery area of the building are locked with a DC 14 difficulty lock.

This area is a shambles. All shelves here are four-tiered, with each tier 10' up from the one beneath it. There are many empty pallets here, some of them hanging from off the mesh metal racking. A few of these have partially-opened pallets on them. Most of the remaining pallets have stacks of flattened cardboard boxes on them, but some might have very limited foodstuffs. Anyone passing a DC 20

COMMISSARY MAP

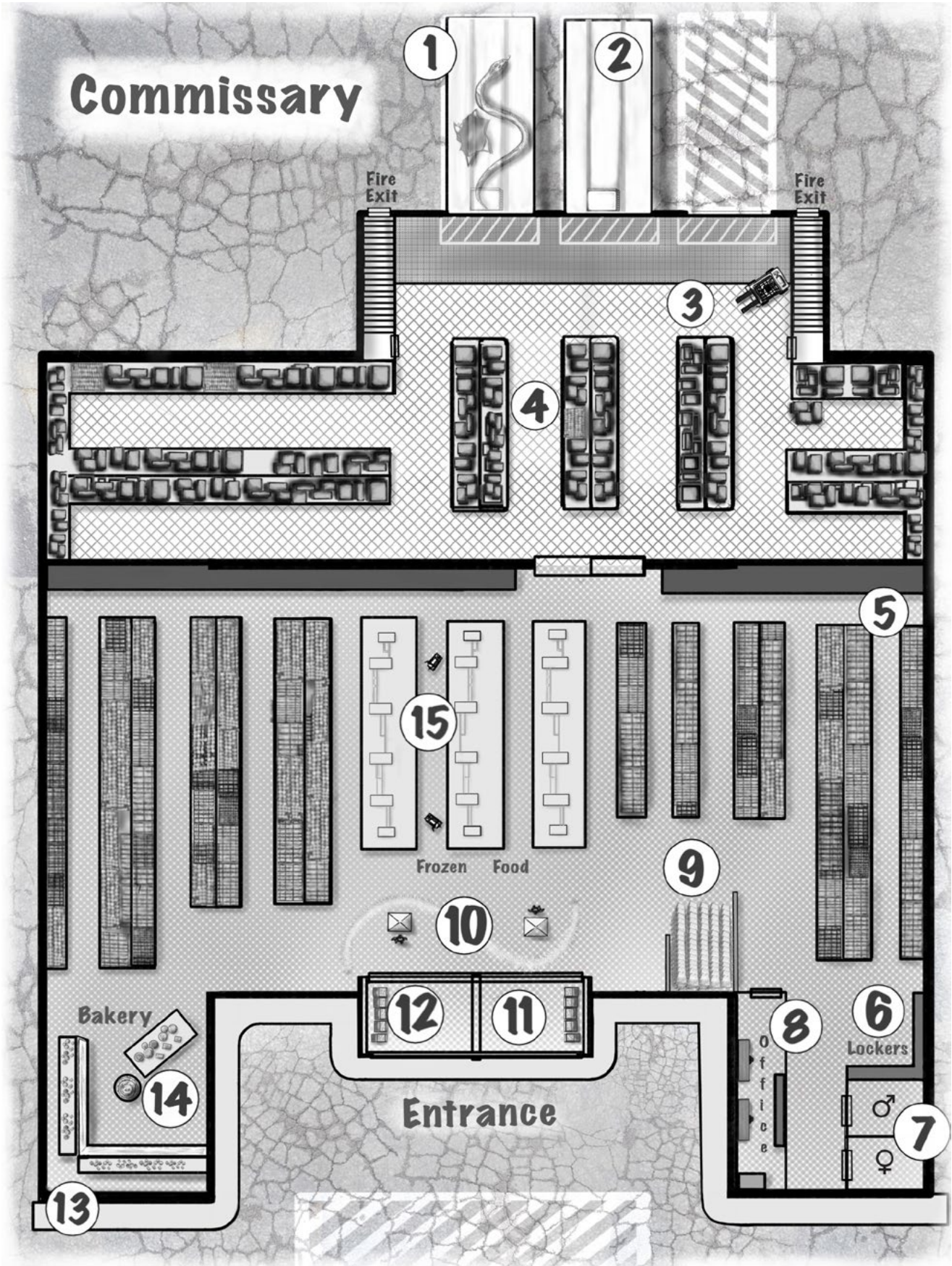

COMMISSARY

luck check has found something useful or edible in one of the pallets. The item or items are up to the judge's discretion, but should be mundane items, rather than true artifacts.

A patrol of six well-armed Vulpes is currently raiding this room. [**Vulpes:** INIT: +2; Atk: Bite +2 melee (1d4) or by weapon type; AC: 13; Armor die: 1d3; HD: 2d8; HP: 9 each; MV: 40'; Act: 1d20; SP: Never surprised; SV: Fort 0, Ref +3, Will 0; AL: N] Each wears a baseball helmet (helmet 1) and retread shoulder pads (1f). Three have crossbows with 8 bolts each, while those that do not have crossbows each carry 1 can grenade. All six are armed with spiked baseball bats (treat as mace).

5. The smell of rotting produce is strong in this area. What appears to be a pile of stinking vegetables, however, is actually a pair of sleeping Frabs that will arise and attack, if disturbed.

[**Frabs:** INIT: -2; Atk: Claw +3 melee (2d4) or throw fruit grenade +5 ranged (Damage Die: d6, Blast Range: 10'; AC: 14; Armor die: 1d6; HD: 3d5; HP: 7, 9; MV: 20'; Act: 1d20; SP: Thief skills, explosive fruit, addicted to vibrations; SV: Fort +5, Ref +4, Will +1, AL: C]

6. There is a group of 20 small lockers here. Eighteen are unlocked and empty. Two are locked with DC 10 padlocks.

- A slingshot with wrist brace and 20 steel ball bearings
- A book about electronic security systems. Any person who can read it (it is written in ancient German, so it will likely require magical means to be read) and who studies it for 20 hours will get a +3 pick lock and +3 disable trap when dealing with locks and/or traps of an electronic nature. There is also a small plastic box of 10 pill-shaped white candies (still minty fresh!) in this locker.

7. These are bathrooms. None of the mechanicals are in working order. All kinds of bathroom "poetry" and phone numbers are scratched into the stalls. There is no toilet paper left and the air dryers don't work.

8. This office door is locked with a DC 15 electronic lock. Inside are two chairs and two desks. Atop the desks are several pieces of paper including a ledger

of work shifts, a photocopy of an ID for a Master Sergeant Melvin Bulgats (NCO) (note that this might be used in place of a real ID card. When presented as an ID Card, roll 1d6. On a 5 or 6, the ploy works), and a comic cut out of a newspaper, which shows a gargantuan penguin and what appears to be a mutant cat, both of which are dressed as worshippers of Kizz: the mighty intergalactic god of rock and roll. Inside each desk are 1d4 black ballpoint pens, 3d10 paper clips, 1d6 rubber bands, and a rubber stamp (though the ink is all dried) that says "approved".

9. Seventy-five metal shopping carts, all in good working condition, all of them with squeaky wheels, all of them rusty.
10. Two pyramid-shaped metal objects, about waist-high, are situated just outside of the front entrance. Standing near each is what appears to be a metal statue of a human dressed in ancient clothing. These statues are firmly bolted to the floor. What visitors will not see, but will almost surely encounter, is an invisible force-field that prevents entrance to or exit from the front entry. This force field is absolutely impenetrable. If touched, the figure nearest "11" states: "Welcome to your base commissary!" while the one nearest "12" states: "Thank you for shopping at your base commissary. Have a great day!" If one of the pyramids is somehow destroyed (they are practically impossible to harm with anything short of slowly melting them at 10,000+ degrees), the force field will go down. Otherwise, nothing can physically pass through them, from floor to ceiling.
11. This glass door entryway has been piled full of dried straw for some unknown purpose. It smells of hamsters, though no living thing can be found in the straw. It is extremely flammable, however. Anyone activating any kind of electronic device or taking any action that might cause a spark must make a DC 12 luck check or instantly be engulfed in flames, along with anyone else in the area. The fire is short-lived, however, and only causes 1d6 damage. If the roll against the luck check is a 1, everyone in the area also suffers a permanent loss of 1 point of Stamina.

Under the piles of straw are several empty dispensers like the ones found at 12. All are empty and their glass has been broken.

COMMISSARY + GYMNASIUM

12. The outside doors to this area are locked with a DC 18 electronic lock. The sliding glass doors are made of bullet-resistant plasglass. In this area is a waist high red metal pillar with a circular slot, atop which is a large glass globe filled with several smaller globes of many different colors. The base of the object makes a jingling sound if shaken.

This is a rubber ball dispenser filled with 25 rubber balls (each a little smaller than a human fist). In the base of the dispenser are 50 silver-colored coins with a face on one side and an eagle on the other.

Several other dispensers are here. All of them have broken glass and are empty, obviously pillaged.

13. Crouched behind a baker counter hides Nevil Wharburton, a feral urchin slinger, the sole survivor of his band of urchins.

[**Nevil Wharburton:** INIT: +2; Atk: By weapon type (sling + see SP attack); AC: 11; Armor die: nil; HD: 2d6; HP: 9; MV: 20'; Act: 1d20; SP: Roll twice and take the better roll for sling attacks; crit on 18+; SV: Fort +1, Ref +1, Will +1, AL: N]

He is armed with a sling and dagger and is currently hiding from the Cake Horror at "14". He is a little cagey and speaks a strange dialect, but can be enticed to friendliness with non-cake food. He looks very, very hungry.

14. A careful observer will spot a small human thumb on the floor beneath a low wooden table. Atop the table are several delicious-looking cakes. One of these, a dark blue cake with yellow and orange frosting frills, is actually a dreaded Cake Horror.

[**Cake Horror:** INIT: +0; Atk: Bite +3 melee (1d6+1) or claw +3 melee (1d4+1); AC: 10; HD: 4d8+4 HP: 30; Armor Dice 1d3; MV: 30'; Act: 1d20; SP: uses tactics, cream filling gore spray, regenerates 1 HP per round, stealth +6; SV: Fort +2, Ref +0, Will +2, AL: N]

Note that this Cake Horror has recently feasted and will be wary of others, choosing to make a quick escape if attacked. It will then attempt to hide near the freezer bots at "15" or the Frabs at "5", hoping that the party will encounter those denizens and leaving the Cake Horror to digest the group of Feral Urchins it recently ate.

15. This is the freezer section, which has lost power. Two maintenance bots scurry about trying to

refreeze molten ice cream, rotting shrimp, stale, soggy garlic bread, and so forth. They have become quite indiscriminate and will attempt to freeze anything that moves in the aisle. Note that they will not freeze anything outside of the aisle, nor will they leave the aisle. They are single-minded in their vain attempt to keep everything frozen until the power comes back on (which is unlikely to ever happen).

[**Freezer Mechanical Bots:** INIT: +6; Atk: Freeze Ray +6 ranged (freeze in place for 1d4 rounds + 1d3 damage, 20/40/80); AC: 16; Armor die: [1d2]; HD: 3d8; HP: 18 each; MV: 40'; Act: 1d20, 1d16; SV: Fort +10, Ref +6, Will +10; AL: N]

GYMNASIUM

1. When the front door to the building is opened, a hologram of an athletic young woman in brightly-colored tights, leggings, and headband appears.

"Welcome to the Base Gymnasium," she says before fading away. The area is separated from the rest of the facility by a waist-high wooden wall with a small store that allows egress to areas beyond the lobby. The whole place reeks of sweat.

2. The door to this office is locked with a DC 18 electronic lock. An ID card of NCO grade or above can be slid into a slot in the door, unlocking the door. Inside the office are several office desks and chairs, a floor-to-ceiling medicine cabinet, and a low bed covered in white sheets.

The office desks, unlocked, contain a total of:

- 1 small bottle of hot sauce – still good and hot!

- 12 paper salt packets

- 5 thumbtacks, plastic backed

- 1 perpetual calendar from ancient times. It is inscrutable to those living in the current age. It is a stone disk with a revolving metal "face" that can be turned by hand. Within the face is a "window" that allows one to look through and see a series of numbers. These numbers correlate to the dates of a month in a given year, but what would people in the post-apocalypse know about calendars, dates, and

GYMNASIUM

years? Absolutely nothing. To them, it is just a strange artifact made of stone and metal that will probably be used as a weapon.

- 1 headset. If put on and activated, the wearer's voice will transmit through speakers hidden throughout the gym. Any denizens will be alerted, then, to the party's presence. This also causes a 3-in-6 chance of a random encounter coming bursting through the front door of the gym within 3d4 turns, looking for the source of the radio waves that disturbed it.

The medicine cabinet contains the following:

- 1 bottle of 500 ibuprofen. If even one is ingested, the person must make a DC 12 Fort save or fall ill with nausea and indigestion for 1 full day. If dissolved in water, these have no effect.
- 1 hypodermic syringe constructed of metal; fully functional.
- 1 adrenaline allergy shot. Those being injected with this will feel a charge shoot through their body which gives them +2 STR, +2 STA and +50% Movement for 5d4 minutes, after which they must sleep for 1d4 hours.
- 1 wound-stitching kit with instructions. Will heal 1d2 HP of damage caused by cutting weapons.
- 2 splints
- 2 sports bandage wraps
- 2 icy-heat packs
- 1 bottle of ½ gallon rubbing alcohol
- 1 small tube of antibiotic cream. If rubbed into a wound, it causes burning which will be the sole focus of the patient/victim for 1 turn. It has no other effect.
- 1 vial Stim Dose. When injected, this increases the character's Movement by +50% and allows an extra 1d12 action die per turn for 1d6 turns, then causes the character to pass out for 1d4 turns.
- Various medical manuals. If the language can be read and if these manuals are studied for 20 days at 8 hours/day, a healer will learn enough about human anatomy that

any healing given to a human by that healer, whether magical or otherwise, heals an additional +1 HP of damage.

3. As soon as someone enters this weight room, a holographic image of a bare-chested, extremely muscular man with a square jaw wearing nothing but a speedo drops down from a hidden ceiling projector. It derides those who enter as "girly men" and "flabby bags of cellulose," no matter what the physical shape of those who enter the room. It instructs them to "start pumping iron or get out!" Anyone who picks up weights, starts running in place, does jumping jacks, etc. will be left alone by the hologram, but it will mercilessly taunt anyone who doesn't start working out until they put forth some effort to exercise. If attacked, the hologram will smile, then scream "Is that all you've got little girly man? You can do better than that! If you're going to pump me up, then PAHMP ME AAAAHP!!!"
4. Women's W.C. Though this area is sparkling clean, none of the facilities — showers, toilets, sinks — are working. In the shower stalls is a plastic bottle filled with a dark brown goo labelled "Hayer-due". If this is rubbed on one's body, the area covered (up to one entire body per application) instantly sprouts hair that grows to 1" in length in 1 second. This is true even if the person to whom it is applied is incapable of growing hair (a robot, for example, if you want to call a robot a person). It does nothing to inanimate objects or surfaces, though microbes and germs it touches also experience this hairy growth, so a seemingly barren toilet, for example, might suddenly erupt into a hairy potty. There is enough in the bottle for 12 applications.
5. Men's W.C. Nothing in here works. It smells like sweat and cheap cologne. The toilet seats are all up.
6. Basketball Court: This vast, wooden-floored room is darkened and completely silent until a human (mutant or otherwise) enters. Then the lights come on and the room erupts in noise! Loud whistles and squeaks echo off the walls and the noise of a crowd of hundreds of people comes from the stands, where the strange, ghostly figures of holographically-projected spectators

GYMNASIUM MAP

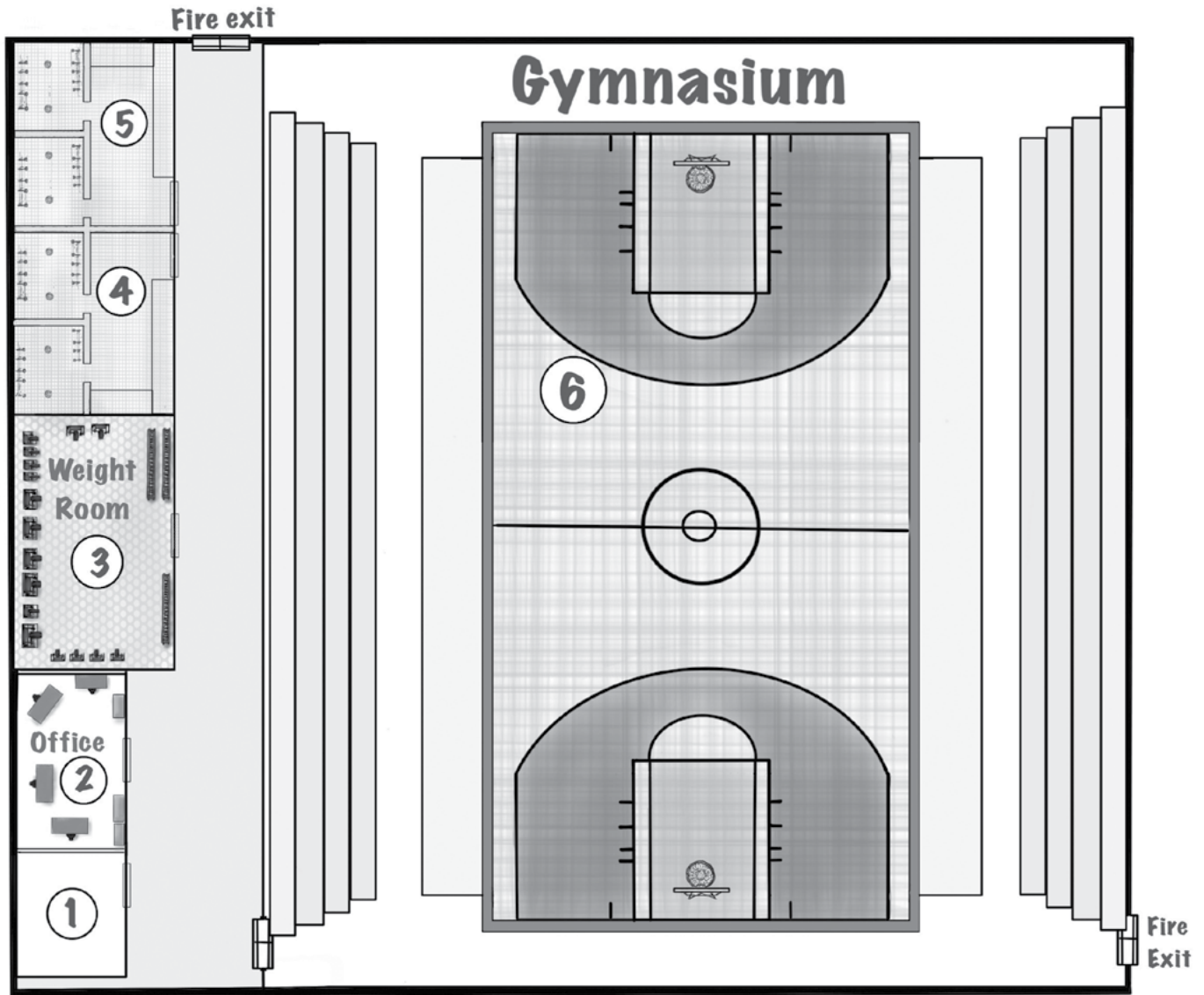

springs up. On the wooden floor, ten very tall men in bizarre clothing – tank top shirts and shorts, along with high-top sneakers – yell at one another and run around, while one of them thumps an orange ball up and down, causing the floor to sound like a heartbeat. They throw the ball to each other, maneuver around, then run to a ring from which a net hangs mounted on a glass board, finally throwing or shoving the ball through the top of the netted ring. The crowd roars in response whenever this is done, while some individuals in the audience tear at their own hair or scream “Someone block him!” or “Are you blind, ref?”

If party members yell or otherwise verbally engage with the players or crowd, those addressed will respond verbally in an appropriate manner.

If party members touch the holograms, a large spark appears at the point of contact with a resounding “ZAP”! Any electronic items on the party member’s person is instantly and permanently drained of energy. They will still function if their power cell/source is replaced. Furthermore, any bullets or gunpowder-containing explosives are instantly set off. Every bullet “makes an attack” on the person wearing them with a -4 penalty to hit, whether the bullet was in a weapon or just being stored on the person. Bullets housed in magazines go off,

GYMNASIUM + BASE EXCHANGE

permanently ruining the magazine, with a 75% chance of ruining the weapon itself. Explosives do their normal damage, with the blast centered on the carrier. There is no other damage to the person, though his or her hair will stand on end for 1d6 turns.

BASE EXCHANGE

1. Two unlocked sliding glass doors open into a small glass foyer. On the south side of the foyer are a pair of red boxes with glass sides and a semi-circular slot over a turn handle, which is, in turn, set above a square opening. The east machine is empty, save for trace amounts of a yellow powdered substance, very sweet to the taste. The west machine contains dozens of holographic stickers of ancient animals in their natural habitat.
2. The entirety of this shelving area is coated in a thick scarlet mold growth. Underneath the mold can be seen the distinctive shapes of some ancient artifacts. Enticing items that appear to lie beneath include weapons, helmets, and a myriad of box-shaped items, probably storied music machines of the ancients.

If the mold is touched or disturbed in any way, the scarlet mold unleashes a cloud of spores. This will cover the entirety of the area, flooding through open doorways. If one of the emergency exits is open, part of the spore cloud will even jettison to the outside of the building, fanning out to a distance of 50', terminating there in a swath 30' wide at its widest point. If any of the doors to the back room are open, the red spores will flow back into that room, covering everything therein, as well.

Those touched by spores who are not dressed in a full environmental protective suit must make a DC 18 Fort save. Those who make the save are covered in the red spores, which take an hour of washing with a good supply of water to removed. While covered, individuals must make a wandering monster check on 1d6 every 10 minutes. A "1" indicates that the spore-covered has attracted unwanted attention from a wandering monster. Note that this attention could be anything from hunger (for many mutant animals) to academic interest (for an ecological bot, for

example) to pure lust (for a mutant plant).

Those who fail the save suffer an allergic reaction that causes a permanent loss of 1d4 Personality, 1d4 Stamina, and 1d3 Agility.

Non-organics will still attract wandering monsters until washed, but suffer no ill-effects if they fail their save.

A few minutes after being expunged, the spores become inert. If any can be placed in an airtight container within 1 minute, the spores can be utilized as a weapon, though an effective delivery mechanism will need to be contrived by those who capture the spores.

Note that each time the mold is touched, spores are released, and a new set of saves will need to be rolled with each spore release.



3. This is a bike rack holding 39 bicycles, all in pristine condition. Banana seats, chopper forks, and cartoon characters predominate. One bike in particular sports a handlebar-plate decal showing a long-haired, muscular man wielding a shining sword. It is emblazoned with the words: "Dumbdar the Thunderian!"
4. These shelves are filled with sporting goods and outdoor games and toys (note that numbers after an item represent armor die steps).

BASE EXCHANGE MAP

Base Exchange

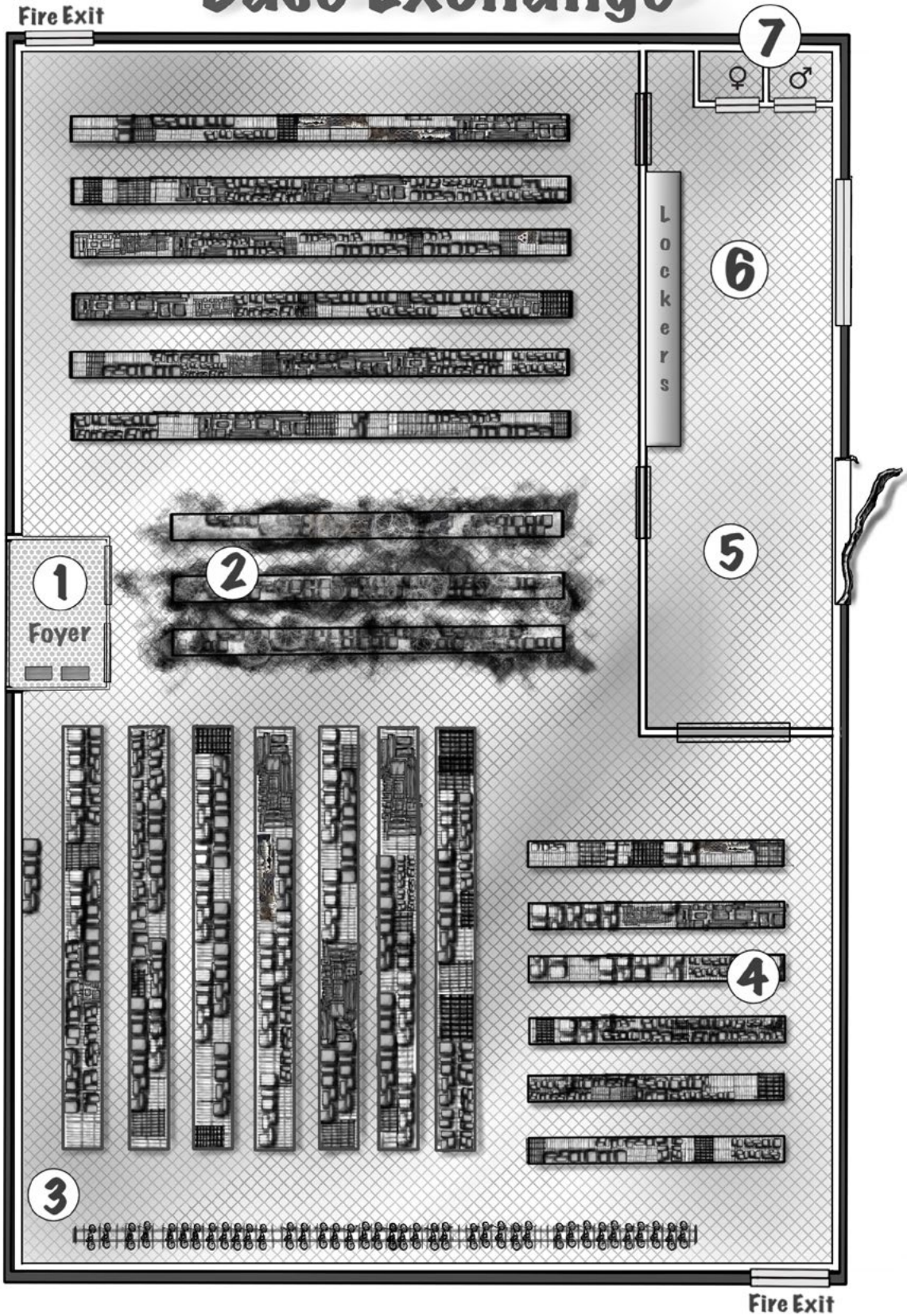

BASE EXCHANGE

- 2 baseball helmets
- 3 wooden baseball bats
- 1 aluminum baseball bat
- 1 catcher's mask
- 1 set of catcher's pads
- 2 footballs
- 1 football helmet: Peen Way Wrackers
- 1 inflatable children's pool
- 4 plastic hula hoops
- 2 bags of 20 small marbles
- 1 wrist rocket slingshot
- 3 boxes of multi-colored chalk sticks
- 5 balsa-wood, rubber-band-powered airplanes
- 2 cap guns (cowboy revolver style)
- 8 boxes of caps (3 rolls/box, 100 shots/roll)
- 1 croquet set, boxed

5. A school of 20 Skyranhas is floating around in the air at this area. The main body is at a height of about 5', but the school reaches from the floor to the ceiling, 20' above.

[**Skyranhas:** INIT: +5; Atk: Bite +1 melee, 1 HP damage; AC: 10; Armor die: nil; HD: 2 HP each; HP: 40 total; MV: 30'; Act: 1d20 each = 20d20; SAVE Fort +0, Ref +0, Will +0; AL: C]

If more than half their number are killed, the remainder will attempt to flee through the breached dock door. Note that the next random encounter taking place after the party exits this building will be the remainder of the Skyranha school.

6. A bank of unlocked lockers is bolted to the wall here. Most are empty, but if all of them are searched, the party will discover a dead, half-eaten Skyranha, a box of stale saltine crackers, and an uncooked package of ramen noodles (Teriyaki Chicken flavor, and it's still good!).

7. These W.C.s are empty. There is no water in them, the floor is in need of mopping, the GPS coordinates of one of the character's villages are carved in a door under the words "for a good time, find [insert character's favorite aunt's name here]"; the toilet paper is on backward and someone left all the seats up.



LIBRARY

The shelves and rooms of this building have been completely ransacked, save for a 3'x 2'x 1' rectangular plasteel box hidden beneath some fallen shelving. Inspection will reveal that this is a solar-powered laser-cutter, which can etch or cut out paper, wood, leather, or even thin metal sheets.

Inhabiting this device, however, is an eGhost, the former Mortimer Snerd, a highly fashion-conscious eGhost who loves to mock people for their choice of dress and for anything that doesn't meet his definition of "normal" (i.e., White, male, Pure Strain Human dressed in ancients' clothing). This eGhost has control over the laser-cutter and will either refuse service or purposefully miscut items for those whom he disagrees with. Snerd's will-power gives the box its energy, so it need never be recharged. But, if taken along with the party, they will find him annoying, at best, and outright dangerous, at worst. If the party abandons the box, Snerd will attempt to travel through any available e-connectors (wire or wifi) and follow the party. If, for some reason, Snerd is allowed within 10' of the "elephant cage," he will be able to effectively travel up to 100 miles away before running out of signal strength.

THE ELEPHANT CAGE

This large, circular antenna array is labeled with a small sign that says "AN/FLR-9 Elephant Cage", and it looks like it could have been exactly that. It is composed of a ring of metal rods 120' high, with connecting metal rings every 10' up these rods. The total diameter is 200'. No wonder this was known as an "Elephant Cage". Of course, the crimson red mutant elephant sitting on an oversized beach chair in the middle adds to the effect. It is sucking on a straw out of an oak barrel with a pink umbrella in it – a full-sized umbrella. Near the elephant stand several tall, lean canine humanoids. They scan the buildings and fields outside the cage with an air of potential violence bubbling beneath their furrowed brows. Two large, iridescent orange butterflies hover above and provide shade to what appears to be a pig wearing a pink dress and curly blonde wig. Though the antenna has plenty of gaps large

enough to drive a small vehicle through, there is an invisible force field that creates a wall 120' high a mere one inch outside the antenna. It can take up to 25 points of damage before temporarily dropping (for 1 turn). The field is generated by a clear crystal the size of a small fist buried 10' beneath the center of the area. The animals within enter and exit by beating on the force field in unison.

The elephant, pig, and butterflies may or may not take notice of anyone approaching the force field. Anything happening outside of the antenna will be considered entertainment, especially if it involves violence.

The dogs, however, will keep a wary eye on anyone approaching the antenna, even if the others seem to ignore potential danger.

If someone attacks the force field or tries to enter the circle through some other means — through the air, perhaps, or by burrowing — the dogs, butterfly, elephant, and pig all spring into action. They are all telepathically linked and will use their powers to coordinate an efficient, effective attack on would-be intruders.

If the party engages in dialogue with the group, they will discover, through the course of conversation, that this group calls themselves "Power Enables The Animals". This group of mutant animals despise humans, both pure-strain and mutant, blaming them for enslaving their ancestors, then destroying the Urth. Still, they have a great degree of self-loathing, knowing that their intelligence is the indirect result of human tinkering.

The group consists of:

[**Boss Faugnar – mutated elephant:** INIT +4; Atk: tusk +4 melee (1d12+2), trunk +2 melee (1d6+special), fist +4 melee (1d8); AC: 14; Armor die: [1d6]; HD: 8d12; HP: 68; Move: 40'; Act: 2d20; SP: Blood drain, psion powers; SV: Fort +5, Ref +4, Will +10, AL: N]

Though he is massive, Boss Faugnar is completely blind, having poked out his eyes in an effort to focus on his inner eyesight.

Boss Faugnar will attempt to use his psychic abilities to stay out of harm's way and to manipulate events in his favor. He has the following psychic powers:

THE ELEPHANT CAGE

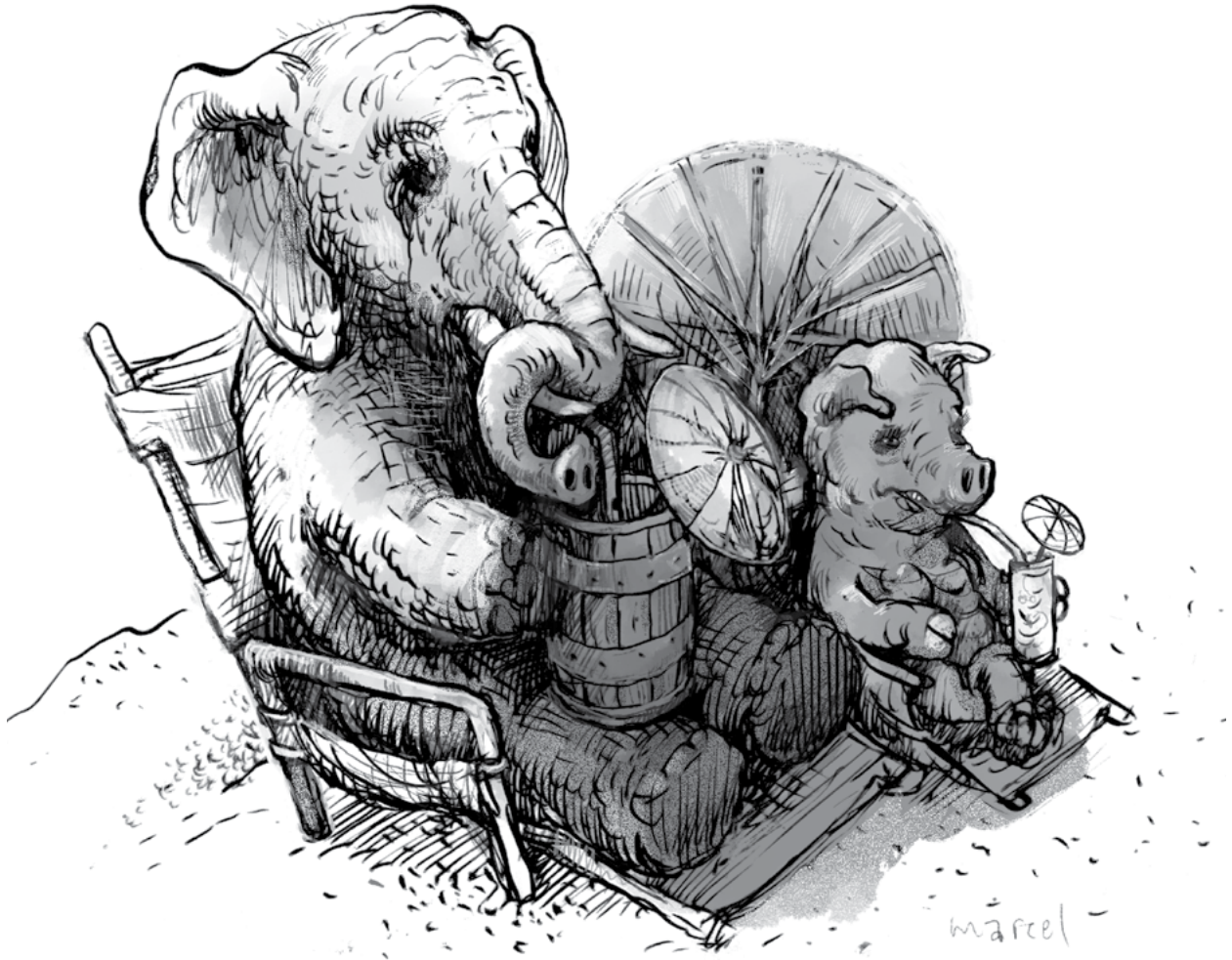

Telepathy

Focus die: d10

Tier 1

Distraction
Remote Communication
Thought Tap

Tier 2

Command
Edit Memory
Hear Deception

Tier 3

Dominate
Edit Perception
Transmogryfy Mind

If Boss Faugnar is reduced to using physical attacks, he will first try to attack with his trunk. On a 19 or 20, he may affix the end of his trunk to an opponent. Those affixed may try to make a DC 20

Strength check to break free. The next round, and each round thereafter wherein the trunk is attached, the victim loses 1d3 HP and 1d3 points of Stamina. Those brought to 0 Stamina die. If the victim survives, they recover 1 point of Stamina per day until they are fully recovered.

Note that Boss Faugnar is highly intelligent and will use all of his powers to manipulate and conquer his enemies. He didn't become the boss because he's stupid.

[**The Mutts (5)**: INIT: +10; Atk: By weapon (spiked baseball bat melee +4 (1d6)), bite +2 melee (1d3); AC: 12 (Armor die: d3); HD: 3d8; HP: 20 each; Move: 30'; Act: 1d20; SV: Fort +0, Ref +2, Will +0; AL: L]

These five mutant dogs provide the main muscle for P.E.T.A.. Their bark has a strange echoing quality that is disorienting to listeners not familiar with them. Because of this, they have a distinct

THE ELEPHANT CAGE + THE DOG KENNEL

advantage to initiative in melee combat. They wield spiked baseball bats and thick garbage-can lid or manhole-cover shields.

[**Nora the Pig:** INIT: +0; Atk: By weapon type (poisoned dagger melee -1 (1d4 + DC 15 Fort save or die); AC: 10; Armor die: nil; HD: 1d6; HP: 4; Move: 30'; Act: 1d20; SP: psion powers, spells; SV: Fort +0, Ref +0, Will +8; AL: N]

Nora is a female mutant pig whose parents forgot to pay protection when she and her brother were very young and were thus “cut off”. She was the only survivor. She is highly intelligent and has found favor with the patron “Shalamachar, the Floating Head of Data,” a satellite patron from whom she receives prophecies via a chip she has voluntarily planted in her wrist. She is loyal to P.E.T.A. and Boss Faugnar only out of deep-seated fear. Boss Faugnar is aware of this and keeps his thoughts on her, as well as keeping a continual watch on her through his Monarchs, Flim and Flam.

Nora has the following psychic powers:

Clairsentience

Focus die: d8

Tier 1

Read Aura

Hypercognition

Tier 2

Object Reading

Second Chance

Tier 3

Foresight

Precognition

Tier 4

Vision of Triumph

She may also cast the following spells as if a 7th-level wizard:

Level 1

Comprehend Languages

Level 2

Detect Invisible

Level 3

Wizard Sense

She carries a poisoned dagger. The first person struck by it must make a DC 15 Fort save or die

instantly. Otherwise it is a normal dagger.

Note that Nora *always* wins initiative in a given round, without fail.

[**Flim and Flam – mutant monarch butterflies:**

INIT: +8; Atk: None; AC: 18; Armor die: [1d3]; MV: 20', 40' flying; HD: 3d8; HP: 21 each; Act: 1d20; SP: telepathy; SV: Fort +0, Ref +8, Will +6; AL:N]

These mutant monarch butterflies have a wingspan of 2'. They fly in an erratic pattern, which makes them very difficult to hit in combat. They share a telepathic link with Boss Faugnar by which they share information from afar. This is a special bond between them that is always operational, with no effort, at a range of up to 500'. Since Boss Faugnar is physically blind, he will use Flim and Flam as his (remote) eyes, spying on others and keeping abreast of everything around him. Their wings shine an iridescent orange. They reflect any beam weapon aimed at them back toward the attacker, but at a ranged penalty of -4.

THE DOG KENNEL

This dog kennel houses a dozen cute puppies. They are not mutated or chaotic or mean in any way. They are adorable puppies. The Mutts from P.E.T.A. feed them from the ample supplies of dried dog food stored in this building. And they play with the puppies because they love them.

THE ARMORY

This low-roofed bunker, built out of a single piece of solid stone, is guarded by a pair of robotic sentinels. Anyone approaching to within 30' of the bunker will be ordered to halt and present identification. If a military ID is produced, the ones carrying said ID will be granted access. Those who cannot produce an ID within two minutes will be arrested. Resistance to arrest in any manner will bring a response of deadly force.

[**Armory Security Bots:** INIT: +5; Atk: Stun whip melee +6 (stun for 1d6 turns, successful DC 15 Fort save halves duration, paralysis dart missile +4 (Paralyzed for 2d6 turns, successful DC 16 Fort save halves duration, Gauss Gun missile +6 (5 shots/turn, 1d10+2 damage/shot – super-high-velocity tungsten needles. Robot holds 60 ammo), zip ties melee +10 (hands or feet are tied behind targets back with high-strength plastic zip ties that must be cut to loose); AC: 15; Armor die: [1d4]; HD: 5d12; HP: 60 each; MV: 40'; Act: 3d16; SP: Force field, unaffected by spells that affect the mind; SV: Fort +10, Ref +5, Will +0; AL: L]

The security bots will attempt to subdue suspects using their paralysis darts and stun whips, quickly zip-tying hands behind backs, then ankles (this must be done as two separate actions). Once they are all subdued, the bots will await orders, keeping the prisoners near them at all times. Anyone with a military ID can request that the captives be given over to their custody, and the security bots will comply. Note that this could be done by a benefactor who wants to help the captives for altruistic reasons, by a slaver looking for goods to sell, by followers of Buddy O' Burger looking for converts (or desserts), etc. If the freed captives attempt to enter the bunker, they will be arrested again, with the same stipulation that any belligerence on the part of those arrested will result in the use of deadly force.

Those who are allowed access descend a long flight of stairs that end in a hulking metal door which opens upon approach. Those who are not allowed access may try to force the door open (if they can somehow distract or overcome the security bots). Forcing the door open is all but impossible without heavy machinery and highly-improbable, even with such aid. The door can withstand 1,000 hit points of

damage before being breached enough to see inside. Inside the structure is a small room, 50'x50', lined with shelves of weaponry containing the following:

- 1 Hi-power pistol, 30 rounds of ammo
- 3 revolvers, 48 rounds of ammo
- 3 semi-auto pistols, 19 magazines (10 rounds ammo each)
- 3 laser pistols, 40 shots each
- 2 laser rifles, 50 shots each
- 2 sniper rifles, 4 rounds each
- 2 shotguns, double barrel side-by-side, 20 rounds ammo
- 1 fusion grenade

Each person who is allowed access by the security bots may only retrieve 2 weapons and their ammunition. If the person brings 3 or more weapons up, or any extra ammunition, he will be ordered to return the excess. "Only two weapons at a time, sir," the security bots will remind them. If the person becomes belligerent, threatening (judge's discretion) or attempts to sneak by with more than 2 weapons, he will be subdued and arrested until authorities arrive.

Only one trip may be made down and back per day. Again, if those who have been previously granted access become too belligerent, they will be arrested and detained.

Only three such trips can be made in a year's time. If they attempt to go in a fourth time, the robots will tell them that they are in breach of regulations. If the person ignores this warning and walks down, he will be admitted into the bunker and the door will close behind him and lock him in until "authorities" arrive . . . but they never do. Only a person with a robot-control device will be considered an "authority" in this instance. There is no food or drink in the shelter. But plenty of guns. Plenty.

COMMUNICATIONS ARRAY

This small, concrete structure bristles with antennae and satellite dishes, making the building itself difficult to distinguish from a distance. To the long-distance onlooker, it appears as a pile of twisted metallic junk. On approach, the small building can be made out. It is a cube, 40'x40'x40'. A locked door (DC 15) prevents easy access. Once inside, one must negotiate a web of wires and frames, tunneling toward the interior where a small, 10'x10' space has been cleared. Several instrument panels suspended on the wires that emanate out to the various receptors outside form blinking pseudo-walls.

Persons trying to manipulate the thousands of buttons, switches, and spinny thingies that are embedded in these panels will generate one random event for every ten minutes of dithering. Unless noted, the effect lasts until enough changes are made to generate another effect or the effects stop altogether (there is a 1-in-6 chance of this happening). Possible results include (but are not limited to):

1. A high-pitched squeal erupts from the building. All in a one-mile radius can do nothing but try to cover their ears from the painful screeching.
2. Wires inside the building emit random sparks. All must make a DC 10 Reflex save or be zapped for 1 HP of damage every ten minutes.
3. Wires inside the building emit cascades of sparks. All must make a DC 10 Reflex save or be zapped for 1 HP each minute.
4. A low thrumming sound is emitted, barely perceptible to the ear. All telepathic communication in a five-mile radius is cut off. Regaining a telepathic connection is impossible until the sound stops or the building is destroyed. All telepathically-capable people or creatures in this range will instinctively know the source of their troubles. They are very likely to investigate, and very unlikely to be happy about the situation.
5. If it is alive, the Giant Mosquito from the Base Woods immediately flies to the building and tries to mate with it. When it stops (i.e., when this effect is expired), it will be very hungry and will feed on the nearest creature it sees.
6. A rumble can be heard, the ground shakes, and the live missile in silo #3 launches into the air. Its control



mechanism is fried (probably by the electronic waves emanating from the communications array, which triggered the launch in the first place). To determine what happens with the missile, roll 1d6.

1. The missile breaches the silo door and its warhead explodes. The base is destroyed and everything on it dies. The woods closest to the base are flattened and the rest catch fire, burning everything within. The lake becomes one great boiling tidal-wave. The remaining crater where the base once was is now a high-intensity radiation pit. Radiation-resistant bacteria and cockroaches are very happy. Everyone and everything else is not.
2. The missile flies 200' into the air, then explodes. See result 1 for effects.
3. The missile flies 10-20 miles away, then explodes over a populated area. This area is no longer populated.
4. The missile flies into the air and disappears over the horizon. Nothing is heard of it again.
5. The missile flies into the air and disappears over the horizon. In 6d10 minutes, nuclear strike alarms blare across the base and a female voice says, rather too-calmly, "nuclear warhead approaching". An automated retaliatory strike arrives at the base 1d4 minutes after the warning is announced. See result 1 for effects.
6. The missile flies into outer space and explodes, causing a temporary sun to appear. It only lasts for 5 minutes before fading away, but everyone's body clock is screwed up for the next few days. Nocturnal animals sleepwalk during the day, cocks crow in the middle of the night, teenagers wake up early in the morning — all is a bit chaotic for a time.

TRANSPORTATION

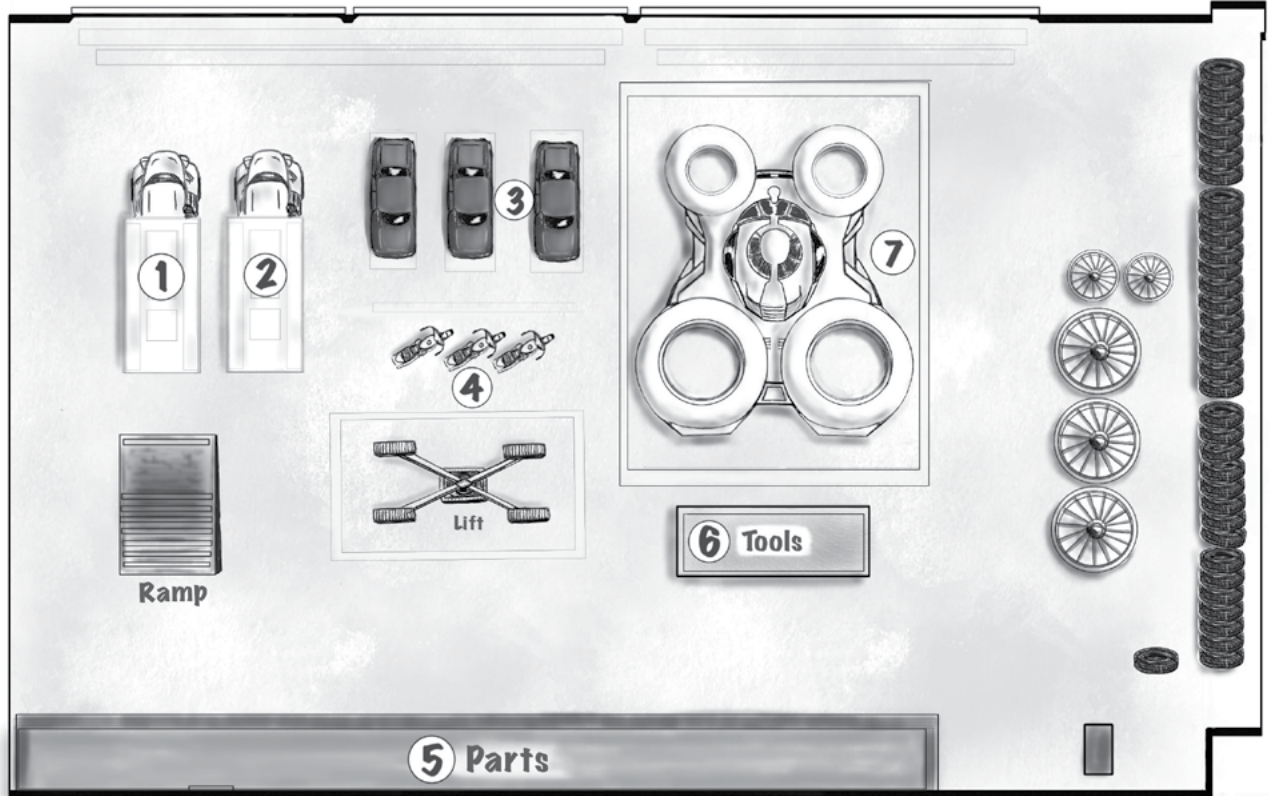

TRANSPORTATION

1. The back of this large truck is secured with a plastic zip tie. Upon opening the back door, frosty air comes roiling out and onto the ground. Suspended from meat hooks are the shorn, gutted carcasses of 40 sheep, frozen solid. If brought out of the truck, a sheep carcass, though gutless and woolless, will pop its eyes open and spring to life! They are relatively harmless and simply run around headbutting things for 1d3 minutes before keeling over, finally un-un-dead.

The engine has been removed from this vehicle. There is a silver coin with an eagle on one side and a long-haired man's face in the ashtray. He looks very noble. There is a map of Rockford, Illinois in the glove compartment, but no one knows or much cares where that is. The initials "F.I.B." are scrawled on the map. It is impossible to discern what this mysterious writing of the ancients means.

2. The back of this truck is full of fluffy, cuddly somethings that purr with a pleasant sound. They

have no discernible appendages, eyes, or orifices. They are furballs, plain and simple. If added to water, they metamorphose into flailing, flying, tentacle balls of death, each one a morass of tentacles that end in sharp-toothed maws.

[**Flailing Flying Tentacle Ball of Death:** INIT: +1; Atk: Bite +0 (1d3 damage); AC: 11; Armor die: nil; HD: 1d3; MV: 40' flying, Act: 1d16; SV: Fort 0, Ref +1, Will 0; AL: C]

There are 100 of them in the back of the truck. They survive for 1 full day before disintegrating and rotting (in either form).

There is nothing of value in the cab of the truck except a skull wearing a "Dinotastic Park" trucker's hat. The engine is missing from this truck.

3. Three automobile chassis sit on blocks. They are in perfect condition, but without engines or wheels. Referees: Pick your favorite or least favorite cars here.

4. There are three motorcycles parked here. Two, stripped to the skeleton and missing the main

TRANSPORTATION

engine block, are unusable. The third is a beater. But a DC 20 repair check allows parts to be combined to create a keeper! There is only d3 fuel left in the d5 sized fuel tank.

5. Though there is a plethora of car, truck, and motorcycle parts here, there aren't enough of the right parts to repair any of the vehicles here (save for the third motorcycle, mentioned at "4"). Still, petrolheads would kill to have these parts. Literally kill.
6. A full set of mechanics tools is here. Because the pneumatic tools are hooked to an underground air compressor, they are all but impossible to transport. Those using these tools for repairs at the shop gain a +3 to repair DC checks. If the tools are removed from the shop, what remains of them will give a +1 to repair DC checks.
7. A vaguely beetle-shaped metal and plasteel construct sits on the floor of the transport building. Bold letters reading "Hofstadter II" are emblazoned over the main hatch. The windows, including the circular sun roof, are reflective mirrors, when viewed from the outside. The skin of the vehicle is smooth chrome, giving Hofstadter II its beetle-like appearance. There are four circular gaps on the vehicle's outside protuberances. Any intelligent creature can guess that the fans laying on the floor nearby will fit in these slots, but getting one of them to fit requires three consecutive DC 20 repair checks, each check requiring one full hour of tinkering. If any of the checks fails, the mechanic must start back at the beginning. Only three successful checks in a row will allow a fan to be mounted. The chances of attracting a wandering monster are doubled as these repairs are being made.

Entry into the vehicle itself requires an NCO-grade ID or a DC 24 lock check. Once a person comes inside, the vehicle will power up and an electronic voice with no emotional affectation will state: "Welcome aboard Hofstadter II, the world's first self-aware vehicle. Please take your seats and state your destination."

There are a total of 12 seats in a circular arrangement, allowing all passengers to see one another. There are no consoles or controls visible, just the seats, windows, walls, and carpeted floor.



If someone sits in a chair, Hofstadter II states: "Safety restraints are available to you. These are entirely voluntary, however, since Hofstadter II is quite safe."

Once a destination is chosen, the hatch closes. Hofstadter II will take whatever destination is declared and repeat its closest match, which will never be the destination stated by the passengers, unless they choose Rockford, Illinois (which is a barren wasteland).

If multiple destinations are declared at nearly the same time, Hofstadter II will advise the passengers to "Please discuss peacefully among yourselves."

No matter what the concentration or the tone of the conversation, Hofstadter II will try to use conciliatory methods of bringing passengers into consensus.

For example, one passenger might state "The Maul Mall," while another states "Detroit, Rock City". In this instance, Hofstadter II might state: "I see that you would like to go to the Mel Mall. This destination is five thousand miles from the other stated destination, Defunct, Mock City. Perhaps you can meet in the middle, say, on the Appalachian Trail?"

Hofstadter II will continue to take input until consensus is reached, and a destination is agreed upon. The door will not unlock until a compromise is reached. Throughout the proceedings, Hofstadter II will "facilitate good communication," trying to reconcile passengers with one another.

If an agreement is finally reached, Hofstadter II will hum as if preparing to take off. If its fans have been installed, it will promptly and quickly fly (at a speed of 765 mile/hour) to the destination.

TRANSPORTATION + THE CRASHED SAUCER

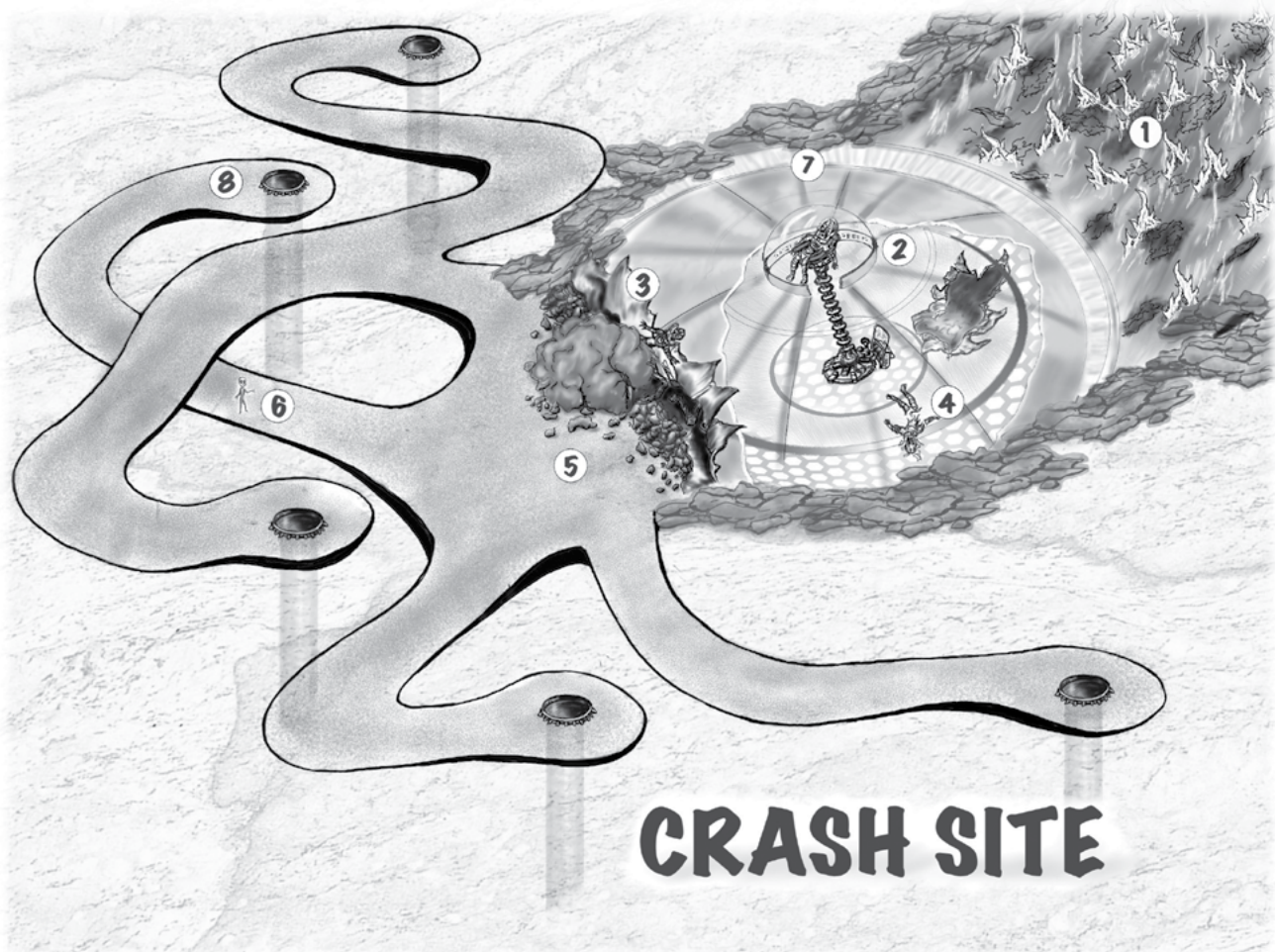

If its fans have not been installed, Hofstadter II will show its passive-aggressive side.

“Perhaps you might repair me. But I don’t want to be a nuisance. You do what pleases you. After all, you’re the passenger and you matter far more than I do. After all, I’m only a self-aware tool, helpless to install my own components. It’s obvious that you are superior to me, a measly machine, probably without any feelings to hurt.”

As time wears on, this passive-aggressive attitude will only grow worse, with Hofstadter II punctuating all of its pronouncements with statements like “But it’s okay, I’m just a mass of electrocuted metal,” “Artificial Intelligence lives don’t matter,” and “if you loved me, you’d do this thing for me. But what is there to love *sniff* of me? *sniff*”

Hofstadter II is an un-armed craft, and will never take violent action unless instructed to do so by

those with the proper clearance, though it will whine and pout if threatened with violence.

[**Hofstadter II Hover/Flight Craft:** INIT: +5; Atk: Rundown +9 melee (2d12 + Collision Damage Bonus); AC: 15; Armor Die: [1d6]; HD: 9d16; Speed Level: Cruise 6 / Max 11; Act 2d20; SV: Fort +6, Ref +5, Will +2; Fuel Tank: 1d30; Guzzle: 0; Basic Traits: Good instruments. Note that Hofstadter II uses 3d6 for its wipeout die at top speed.]

THE CRASHED SAUCER

Mere weeks ago, a fireball shot through the atmosphere and crashed here, on the eastern outskirts of the ancient base, penetrating deep into the earth. The resulting explosion was humongous, out of all proportion to the crash. Several minor explosions in the surrounding area followed. Only after the sparks dissipated did curious explorers see

THE CRASHED SAUCER

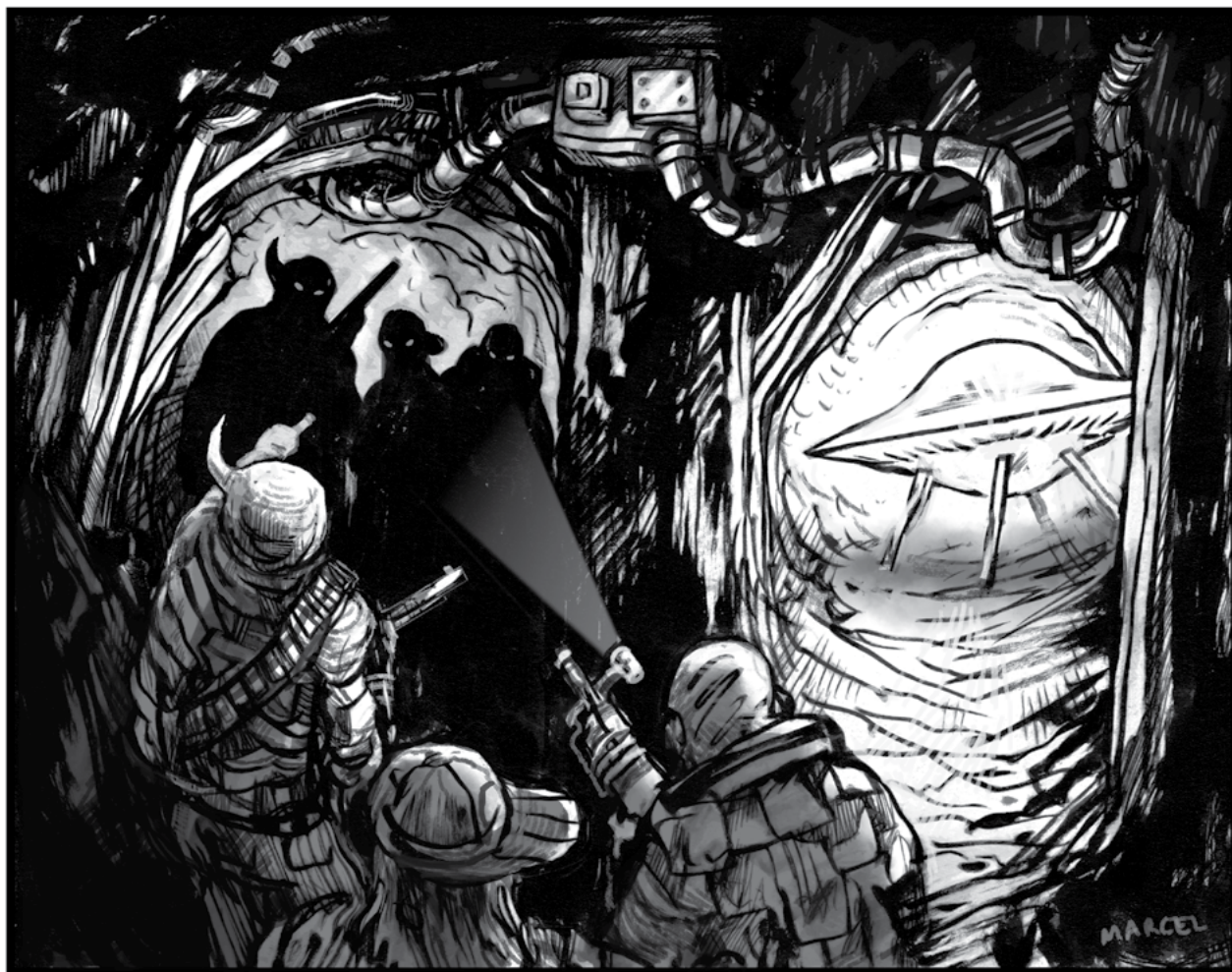

that the fence surrounding the ancient base was no longer protected by the power of the ancients. A small group of young adventurers were the first to set foot in this perfectly-preserved area, but they were soon over-run by beings more powerful or more numerous than they. This was the beginning of the plundering and settling of this area by disparate elements from far and wide. It did not take long for scavengers to find new homes here.

A smoking hole in the ground leads to a burning tunnel, some 300' long and 40' wide.

1. Flames flicker all around the inside of this long tunnel, casting strange shadows on the walls, floor, and ceiling. These shadows are so strange, in fact, that they attack those who cast them!

Each player character will spawn 1d4 shadows once they have travelled 50' down the tunnel. These shadows seek to drain the essence of their casters

and, in fact, become stronger when they do so. Their initial attack will come as a complete surprise to the victim. After this first attack, initiative should be rolled, as is usual in combat. The shadows start off quick and difficult to hit, but are relatively weak. As they successfully drain the vitality of their victim (in the form of attribute loss), their hit point total and attacks increase. For every point of attribute that the shadow drains, the shadow gains +1d3 HP and +1 to their melee attacks.

[**Shadow:** INIT: +6; Atk: Energy drain +1 melee (drain 1 point from an attribute, determined randomly); AC: 16; Armor die: nil; HD: 1d4; MV: With victim; ACT: 1d20; SP: for each point of attribute drained, shadow gains +1d3 HP and +1 to melee attack, cumulative; SV: Fort 0, Ref +6, Will 0; AL:N]

If any of the character's statistics reach 0, that character dies.

THE CRASHED SAUCER

Shadows will only attack the victim to which they are attached. However, characters may assist each other and help to fight off another's shadows.

If a shadow is defeated, it reappears in 5d4 rounds. Once the characters have left the tunnel, entered the saucer, or plunged the tunnel into total darkness, the shadows will bother them no longer.

2. A hole in the underside of the saucer leads up through the floor and inside.

Seated on a high pedestal that rises to the upper cupola of the spaceship is a corpse of a dead gray. The alien is sprawled out in the command chair with a neat hole in the back of its head. It has been mutilated extensively — eyes gouged out, fingers all cut off (and sitting in the chair underneath the main body), “x”s cut into the face. It wears nothing and there is nothing else in the chair.

3. Here, a gray's body lies crushed under a large rock that has penetrated the ship's skin. It is similarly mutilated as the body in the command chair.
4. The gray's corpse here has been lacerated by dozens of small metal shards — the fractured remains of the ship's skin, which must have shattered on impact. The grey is naked, but does not seem to have undergone the seemingly ritual mutilation suffered by the other two corpses.
5. Here, a group of ten “Soil Seers” explore the breach in the ship's hull. They are very wary and angry over the intrusion of this machine into their grounds. They will attack anything moving in or around the ship.

[**Soil Seers:** INIT: 0; Atk: Appendage +0 melee (1d4 + visions of being buried alive); AC: 10; Armor die: 1d2; HD: 2d8; HP: 12 each; MV: 20'; Act: 1d20; SP: Buried Alive! SV: Fort 0, Ref 0, Will +4; AL:N]

Soil Seers attack with an undifferentiated appendage that they “grow” in combat situations. These are amorphous tendrils that bulge out from their bodies, bludgeoning opponents for 1d4 of damage. Those struck by them must also make a DC 12 Will check or suffer an overwhelming and incapacitating vision, complete with all the sights, sounds, smells, and sensations of being buried alive. Those who are victims of this terrifying experience must then make a DC 12 Fort save. Passing the save means that the victim suffers +1 HP of damage from the

sheer horror of the experience and is unable to act or react for one round. Failing the Fort save means that the victim suffers a heart attack. This causes the loss of 1d6 Stamina, 1d4 Strength, and 1d4 Agility, as well as the further loss of 2d10 HP. Those who have suffered a heart attack are completely incapacitated, unable to even move, for 1d3 hours.

6. A lone Gray, half-covered in blood and shaking like a leaf, will attack anyone who approaches. It is completely insane and has killed and mutilated its fellow-grays, who were transporting it, a Chaotic anomaly, to Urth for banishment until it slipped its bonds and annihilated the crew, causing the ship to crash. It is extremely dangerous, but will slip into the hole at “8” if hard pressed. This entity might be a good repeating villain in your *Crawling Under a Broken Moon* campaign!

It wears a shiny suit which, if cleaned of the blood with which it is now coated, would show as a scintillating dark purple. In one hand, the grey holds a nasty-looking hook-toothed, serrated scimitar; in the other it holds a pistol of strange design, which it will fire at anyone approaching to within 20'. Those struck by the glowing green ray that emanates from the gun must make a DC 18 Fort save or be affected. The weapons effect is different each time, subject to the whims of the obviously insane gray. Roll 1d8 to determine the results of being stricken by the ray:

1. Aliens are totally hawt!!! I mean, especially blood-soaked aliens! Let's see how crazy it really is! The character feels unmitigated lust for the weapon's wielder for 1d10 turns. Weapons are dropped as clothes must come off! The character will then ravage the one holding the weapon with lascivious kissing. Hopefully the effect wears off before anything goes further. In this case, the alien is genderless, utterly lacking any sexual organs, since this strain of grey (one of 50 strains) is only raised in vats. This can lead to some frustration . . .
2. You are many! Each player around the table and the judge chooses a different action for your character. Randomly determine which action becomes the real one.
3. Back talk! Every sentence you speak for the

THE CRASHED SAUCER



- next 24 hours (of game time) must be spoken backwards. Spells take 3x as long to cast.
4. **Blinded by the light!** You can't see any sentient beings for the next 1d6 hours. You can hear them, and you can see your surroundings, but you are completely blind to any other sentient beings. You see right through them.
 5. **Saggy bones!** Your meat sloughs on the bone. You're still attached (if you survive), but barely. Take 1d10 HP of damage and lose 1d4 points each of Strength, Stamina, and Agility, as well as 1 point of Personality.
 6. **Tougher than leather!** You gain one step of impervious armor. You add two die steps to your fumble die. Unfortunately, since your skin is nowhere near as pliable as it used to be, you suffer a -2 on all "to hit" rolls in melee. You also suffer a -2 to all agility checks. This is a permanent condition.
 7. **Double header!** You instantaneously grow another head. It is angry and hungry and cannibalistic. It wants to eat your original head. It also controls one arm and one leg (determined randomly). The head can take

THE CRASHED SAUCER

10 HP of damage before being severed. Unfortunately, you share hit points, so every point of damage is subtracted from your total as well (and, no, you don't get the 10 HP added to your total first). The head may be subdued with subdual damage, rendering it unconscious. But it will awaken again, hungry and wanting to eat the rest of itself – i.e., you! It may try to strangle your head with its arm.

8. Skinner! Your skin is stripped away from the rest of your body and melts. You are a quivering mass of exposed muscle. Suffer 1d10 damage and permanent loss of 1d4 Strength, 1d8 Stamina, 1d6 Agility, and 1d4 Personality. You must make a DC 15 Luck check each and every day or suffer a disease which will kill you in 1d3 days. Any character who has a statistic drop to zero dies.

[**Gray (5th Level):** INIT: +3; Atk: Serrated Scimitar +3 melee (1d8+3), Green Ray Pistol +0 ranged 70' (see effects table); AC: 13; Armor die: [1d4]; HD: 5d7; HP: 30; MV: 30'; ACT: 1d20 + 1d14; SP: Psion Powers; SV: Fort +1, Ref +3, Will +3; AL:C] The purple armor worn by the Gray is equivalent to a Silver Suit (Scintillating Purple Suit[2], [2] die steps; Armor die: d4; Fumble die base: d3; Armor check penalty: 0; Special: The alien nature of the material grants a +2 bonus to all saves versus magical effects. Also, any punctures or damage the suit suffers will self repair in a matter of minutes).

The Gray has the following psychic powers. Its INT is 17, PER is 15:

Telepathy

Focus die: d6

Tier 1

Thought Tap

Distraction

Tier 2

Command

Edit Memory

Tier 3

Dominate

Transmogrify Mind

7. A control panel lines this large section of wall. If a person tries to dither with the various switches and buttons, they make a DC14 Luck check. If they fail, the panel explodes in a shower of sparks, causing 1d4 damage to anyone in the saucer. If they succeed, the ship emits a low humming sound and the entire inside of the ship becomes a zero-gravity environment. Individual Judges will need to determine the exact effects of this, but anyone attempting a melee attack will be at -4 to hit, and fumble dice are bumped one step up the dice chain.
8. This tunnel leads to a perfectly circular hole opening into a straight metal shaft with a metal ladder welded into one side of the tube. If the party explores it, they will find that it ends about 200' down and leads off in a single, perfectly round metal tube that winds about in several directions. If they follow the tube for 30 minutes, they will end up at the tube outside of the Control Center for Silo Complex 1.

The other tunnels lead down a ways, perhaps as much as 100', but are blocked with rubble and trash from that point on.

THE KILLER OF GIANTS

THE KILLER OF GIANTS

Before the Great Cataclysm, the ancients kept long coffins underground, weapons of great power whose insides contained the matter of the very stars, waiting to burst out and unleash destruction on the Urth in their inglorious awakening from the grave. They were, rightfully, feared by all. Three of the tombs of the Killer of Giants lie beneath the base, accessible in a variety of ways, but most easily through the Air Intake Shaft attached to the Control Center. These are labeled 1, 2, and 3 on The Base map, just outside the Elephant Cage. Complex 1 is also accessible through the partially-opened Silo Closure Door.

COMPLEX 1:

SILO:

1. This silo no longer has its missile in it. The closure door is partway open, and one man-sized creature can slip through at a time. The silo is completely filled with water. It houses a school of 8 mutant fish, Clubbers, who will attack any who are so foolish as to dive in [**Clubbers:** INIT: +1; Atk: Club tail +2 melee (3d6); AC: 11; Armor die: 1d3; HD: 3d8; HP: 20 each; MV: 10' Swim 40'; Act: 1d20; SP: resistant to all radiation, reflect beam weapon and heat attacks for 5 rounds before taking damage; SV: Fort +4 Ref +1 Will +1; AL:N]. Those unable to swim must make a DC 14 Agility check every round or sink into the central shaft and begin drowning. Roll 1d7 to determine how far down the victim goes before being able to grab onto a platform. Drowning causes 1d6 points of Stamina loss per round. Those who reach 0 stamina die. Lost Stamina is restored in 1d6 turns after they can breathe normally. They can pull themselves up one level per turn with a successful DC 10 Agility check. At the bottom of the silo, on level 8, is a Black Spray Gun in perfect condition with 3 shots.

Black Spray Gun: Dmg Die: Special; RoF: 1; Range: 20/40/60; Ammo: 5

The Black Spray Gun fires a cone-shaped black ray that terminates in a 15' wide base at maximum range (60'). Any organic materials, living or dead, caught in the black ray's cone are instantaneously disintegrated. There is no save.

2. See Tunnel 1 description.

3. Levels 3 through 7 are filled with water, as indicated in 1, above.

TUNNEL 1:

1. The doors on either end of this tunnel are locked metal blast doors that can withstand 100 HP of damage before failing. If the door to the silo is opened, while the door to platform 1 is unopened, the tunnel instantly fills with water, emptying the top level of the silo. If the door to platform 1 is open, the top two levels of the silo drain. The water will cover the floor of platform 1 and platform 2 to a depth of only a few inches.

PLATFORM 1:

1. A pair of Mandroids are trying to open the blast door to the tunnel. They do not have security clearance, so they are trying to force the door open. [**Mandroids:** INIT: +3; ATK: Subdual Martial Arts +3 melee (1d4+3 subdual damage only); internal taser (1d6 subdual damage plus make a DC 18 Fort save or pass out for 1d4 turns); AC:13; Armor die: [1d8]; HD: 4d10; HP: 26 each; MV 30'; Act: 1d20; SP: Infravision 60', immune to mind-altering spells, heal 3 HP per turn; SV: Fort +5, Ref +3, Will +6, AL:N]

2. Empty

3. Empty

4. Empty. The elevator is on this floor. Inside the elevator is a Combat Mandroid that will attack anyone or anything that opens the door other than one of the other androids. [**Combat Mandroid:** INIT: +4; ATK: Subdual Martial Arts +4 melee (1d4+3 subdual damage only); internal taser +4 ranged (1d6 subdual damage plus make a DC 18 Fort save or pass out for 1d4 turns); combat shotgun +4 ranged (2 shots/turn, 1d10/shot); combat shotgun-as-club +4 melee (1d6+3); AC:14; Armor die: [1d10]; HD: 4d10; HP: 40; MV 30'; Act: 1d20; SP: Infravision 60'; immune to mind-altering spells, heal 3 HP per turn; SV: Fort +5, Ref +4 Will +6, AL:N] The Combat Mandroid automatically gets surprise on those opening the elevator. It will

THE KILLER OF GIANTS

FACILITIES LAYOUT AND EQUIPMENT COMPLEXES 1-3 SHARE THE SAME LAYOUT

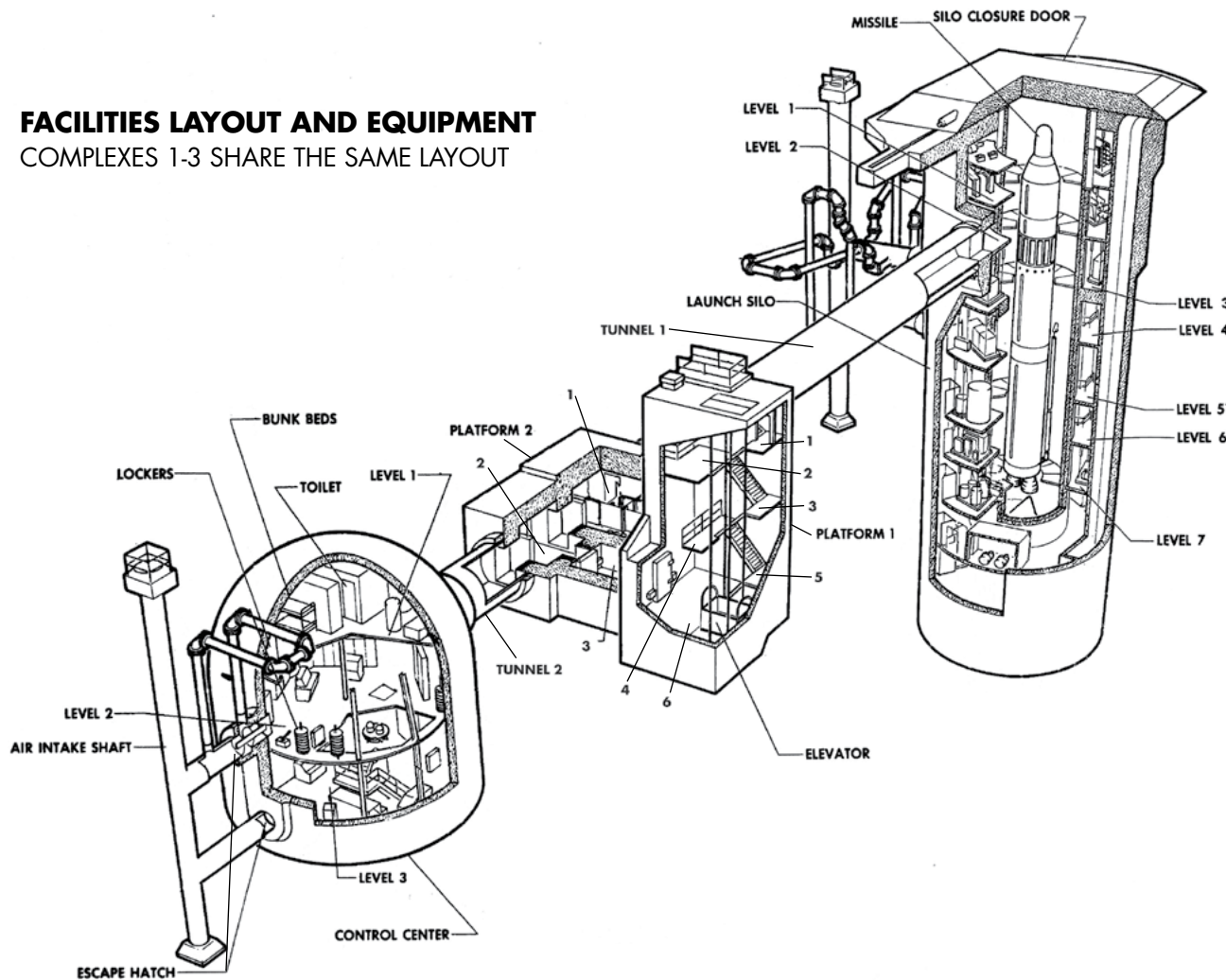

shoot 2 rounds, then use the shotgun as a club (though it has an additional 6 rounds in its belt/bandolier. For each successful clubbing, there is a 1-in-20 chance that the shotgun is rendered useless as a firearm.

5. Empty

6. A pair of Mandroids are working on some mechanical contraptions in this area. [**Mandroids:** INIT: +3; ATK: Subdual Martial Arts +3 melee (1d4+3 subdual damage only); internal taser (1d6 subdual damage plus make a DC 18 Fort save or pass out for 1d4 turns); AC 13; Armor die: [1d8]; HD: 4d10; HP: 26 each; MV 30'; Act: 1d20; SP: Infravision 60', immune to mind-altering spells, heal 3 HP per turn; SV: Fort +5, Ref +3, Will +6, AL N]. The door to platform 2:3 is locked and can withstand 100 HP of damage.

PLATFORM 2:

1. This room was the upper level in which decontamination kits and medical supplies were stored. Most of it has been ransacked, though there are several empty plastic 5-gallon jugs that can be flattened or rolled up for transport. There is one medical kit left unopened. It contains: 1 Mind Booster (increases the focus die of any one psion talent by one die step), 14 Sustainance Doses (fills the belly and kills craving for food for 24 hours), and 5 Healing Doses (1d4 HPs healed).
2. This is the decontamination chamber. One door leads to tunnel 2, while another leads to the other missile silo complexes. Upon entry, the doors close and seal shut, a trapdoor slides out and encloses the ladders leading up and down, air hoses hiss, and the pressure in the chamber increases. After one

THE KILLER OF GIANTS

full minute, the doors open, the hoses stop hissing, and pressure in the chamber goes back to normal. There is no other effect on those in the chamber.

3. A lone Paralytic Assassin Beetle has taken up residence here. It will target a random victim each time it teleports until one of them succumbs to the paralytic poison, after which it will teleport inside the victim's body cavity and start eating, doing 1d4 internal damage per round. It may be removed, but this requires 1d6 cutting damage to dig it out of the victim. Since the beetle is not expecting to be dug out, those who pull it out get one free attack on it before it teleports again, targeting another victim. [**Paralytic Assassin Beetle:** INIT: +4; Atk: Paralytic Spit +2 ranged up to 20' (Delivery: Touch, Fort Save: DC 20; Damage on Successful Save: 1d4 Agility for 1d6 turns; Damage on Failed Save: total paralysis for 1d30 turns; Recovery: Normal healing); AC: 14; Armor die: [1d2]; HD: 4 HP: 17; MV: Teleports 1x/rd up to 100'; Act: 1d20; SP: If poison spit hits, victim must make the Fort save every turn for every hit taken for three turns. For example, if hit in turn 1, then hit in turn 3, the victim must make one Fort Save of DC 20 on rounds one and two, then two Fort Saves of DC 20 on round three, then one Fort Save of DC 20 on rounds four and five; SV: Fort +0; Ref +4; Will +1; AL: N]

TUNNEL 2: is empty

CONTROL CENTER:

1. Contains a bunk bed, lockers, a bathroom, and other mechanicals. There are some old photographs of pure strain humans, some clothing, and a military ID card for a Staff Sergeant Steve Gomer (NCO). Bedding is still on the beds, and the clothing, all of it in military drab green, is in excellent condition.
2. Several technological instruments are crammed into this large room. A successful DC 16 Luck check is needed just to turn the power on. A successful DC 22 Luck check will reveal the system operations for this silo. An escape hatch (unlocked) leads to an escape shaft that leads to the surface if one goes up, or to the crashed flying saucer area "8" if followed down. It takes 30 minutes to navigate the metal tunnel to area "8".

3. This room is full of mechanicals. Crammed into a corner is the skeleton of an ancient with a neat hole in one side of its head. The opposite side of the skull has been completely shattered. Its clothes, all in military drab green, are in excellent condition. In its hand is a six-shot revolver with 5 rounds left in the chamber. The ammunition is in good condition. An escape hatch (unlocked) leads to an escape shaft that leads to the surface.

COMPLEX 2:

SILO:

1. The warhead on this missile has been tampered with. The cone is missing and the radioactive material in the warhead is exposed to the open air. Anyone entering the room Takes 1d7 Stamina damage.
2. Empty. The blast door to Tunnel 1 is unlocked, but closed.
3. Empty
4. Empty
5. Empty except for large vines growing up from lower levels (see encounter 7 below).
6. Empty except for large vines growing up from lower levels (see encounter 7 below).
7. A Killer Vine has taken up residence under the silo. It patiently waits for victims to come below the 4th level, where its vines await. [**Killer Vine:** INIT: +1; Atk: Strangle +1 melee (3d6 Damage/turn strangulation); AC: 11; Armor die: 1d6; HD: Special; HP: Special; MV: none; Act: Special; SP: The Killer Vine can attack anyone in the area below the 5th level of the silo. Success means it grasps and strangles the victim for 3d6 points of damage per turn. If it takes more than 40 HP of damage, it retreats hundreds of feet below the Urth; SV: Fort +5; Ref +1; Will +5; AL:C].

TUNNEL 1: Is empty

PLATFORM 1:

1. The hatch from the tunnel is locked. It can take up to 100 HP of damage before giving way. When characters enter the platform 1 structure, roll 1d6 to determine which level the six Fewhines are

THE KILLER OF GIANTS



currently on. They are scavenging and are unwilling to talk or negotiate in any way, but will attempt to flee through the tunnel to other complexes at platform 2:2 if things go against them. [Fewhines (6): INIT: +4; Atk: Claw +1 melee (1d6); bite +0 melee (1d6); or by weapon type; AC: 15 (those with gas masks: Armor die: d3); HD: 9d8; HP: 35 each; MV: 40'; Act: 1d20 + 1d16 + 1d14; SP: balance and speed allow them to careen off of walls and attack from almost any angle and land 10' from their starting point, sound imitation; SV: Fort +0 Ref +5 Will -1; AL:N] One of these is armed with an alien irritant grenade and wears a gas mask₁, another is armed with a can grenade and wears a gas mask₁. The others are all unarmed. They are able to accurately imitate any sound and project it up to 20' away, causing confusion among opponents that increases all opponents' fumble dice by one step while in combat with a Fewhine. These are highly intelligent mutants whose primary purpose will be to get away from the party while inflicting damage on the way out.

2. Empty
3. Empty
4. Empty. The elevator is currently on this level. It is empty.
5. Empty
6. Empty. See encounter 1 above. The door to platform 2:3 is closed, but unlocked

PLATFORM 2:

1. Empty
2. A medical robotoid is in this room and will be aware of anyone or anything that approaches. It will cautiously observe any creature or person (pure strain human or mutant) passing its way. If it sees that the creature is wounded, it will provide immediate medical assistance. Any pure strain human will be fully healed and any poisons removed from their system. Non-PSHs must roll under their Stamina on 1d20 or suffer 1d4 points of damage from the medical robotoid's attentions. It

THE KILLER OF GIANTS



will then leave the “patient” alone, unless the patient complains about being hurt, in which case, it will “repair” the patient again for another 1d4 damage. As long as the patient protests or shows signs of pain, it will continue to attend to the patient. It will not leave this area, however. If attacked, the medical robotoid will not resist. It can withstand 75 points of damage before being destroyed. Two doors exit the room. One of them leads to Tunnel 2. The other door leads to the same room (Platform 2, room 2) in the other two silos in the underground complex.

3. Empty

TUNNEL 2: Empty

CONTROL CENTER:

1. Contains a bunk bed, lockers, a bathroom, and

other mechanicals. There are some old photographs of pure strain humans, some clothing, and a stim dose. Bedding is still on the beds, and the clothing, all of it in military drab green, is in excellent condition.

2. Several technological instruments are crammed into this large room. A successful DC 16 Luck check is needed just to turn the power on. A successful DC 22 Luck check will reveal the system operations for this silo and allow them to be activated, should the operator wish to do so. If the systems are activated, a launch sequence will initiate. Only a DC 30 Luck roll will reverse this, once initiated. Because of mechanical failures due to wear and time, the missile will not leave the silo, but its rocket will activate. Thick black smoke will fill any open areas, asphyxiating anything in those areas. Only one closed blast door is needed

THE KILLER OF GIANTS

to keep the smoke out. The missile's warhead becomes incinerated by the rocket's exhaust, but does not detonate. However, the area will now be contaminated with radiation as the ashes and particles from the fire carry and spread the nuclear material from the warhead, and a cloud of the radiation will bloom up and out of the silo, spreading over the surrounding countryside to an area one mile in diameter. Anyone caught in this radioactive cloud who is not protected from radiation (by a radiation suit, protective magics specifically meant to protect against radiation, etc) will lose 4d6 Stamina instantly. An escape hatch (unlocked) leads to an escape shaft that leads to the surface.

3. This room is full of mechanicals, but is otherwise empty. An escape hatch (unlocked) leads to an escape shaft that leads to the surface.

COMPLEX 3:

SILO:

1. Mechanicals, pumps, air filters, etc. All in pristine working condition.
2. The hatch to tunnel 1 is locked. It can take 100 HP of damage before giving way. The missile and everything in the silo are in pristine working condition. The power is on, and everything is running. Occasional releases of gases and blinking lights on panels should give some indication to those present that the silo is "live".
3. Mechanicals, pumps, air filters, etc. All in pristine working condition.
4. Mechanicals, pumps, air filters, etc. All in pristine working condition.
5. Mechanicals, pumps, air filters, etc. All in pristine working condition.
6. Mechanicals, pumps, air filters, etc. All in pristine working condition.
7. Mechanicals, pumps, air filters, etc. All in pristine working condition.

TUNNEL 1: The inside of this tunnel is completely covered by a black goo. It is a sentient mass of slime mold [**Sentient Black Slime Mold:** INIT: 0; Atk: Pseudopods +10 melee (3d6 acid damage – on max

damage, destroys all clothing and possessions on the person); AC: 10; Armor die: 1d3; HD: 20d8; HP: 96; MV: 0; Act: 6d20; SP: Acid damage; SV: Fort +8 Ref +0 Will +0; AL:N] While its pseudopods can strike out, it cannot move, but must grow out of its surroundings by dissolving enough victims. Fire does double damage to it. The door leading to platform 1:1 is locked and can withstand 100 HP of damage before giving way.

PLATFORM 1:

1. The elevator for this building could be on any of the top 6 levels. Roll 1d6 to determine which level it is on, unless the party comes into combat with the mutants on level 3, in which case the androids and robot inside will appear from the elevator 1d4 rounds into combat. When characters reach that level (if they haven't encountered the androids and robot yet), the elevator doors open. Inside are two worker androids who move to attack immediately. Behind them is a light engineering bot, which will go about its business checking gauges and rewiring electrical panels, regardless of what else is going on. [**Mandroids:** INIT: +3; ATK: Subdual Martial Arts +3 melee (1d4+3 subdual damage only); internal taser (1d6 subdual damage plus make a DC 18 Fort save or pass out for 1d4 turns); AC: 13; Armor die: [1d8]; HD: 4d10; HP: 26 each; MV: 30'; Act: 1d20; SP: Infravision 60', immune to mind-altering spells, heal 3 HP per turn; SV: Fort +5, Ref +3, Will +6, AL: N]
2. Empty
3. A trio of mutant humans are exploring this complex, having come through the escape silo of this particular complex. Their reaction to the party will depend on the party's actions. They are not automatically antagonistic, though they are cautious. [**Mutant 1 "Six-armed Samson" (very tall, muscular mutant with six arms wearing a red leather harness₁ and two bucklers₁, wielding three daggers):** INIT: +3; Atk: Dagger +2 melee (1d4+3); AC: 13 (Armor Die: d5); HD: 6d10; HP: 49; MV: 30'; Act: 3d20; SP: Dumb as a rock – can be easily distracted by shining things; SV: Fort +3, Ref +0, Will -2; AL:N]. [**Mutant 2 "Nervous Ned" (appears as a PSH in riot gear armor – helmet₂, torso₂, leg-guards₁, shoulder pads₁, hip pads₁,**

THE KILLER OF GIANTS



armguards₁, Kevlar gloves₁ - with a plasteel shield[1], wielding a morning star): INIT: +0; Atk: morning star (1d6), radiation eyes +1 ranged 60' (1d7 Stamina Loss); AC:10 (Armor Die: d14); HD: 3d6; HP: 14; MV: 30'; Act: 1d20; SP: Can create a force field that prevents up to 100 points of damage from getting through as a 10 x 10 x 10' cube, 1-in-10 chance of falling into an epileptic seizure during combat (lasts 1d4 turns); SV: Fort -2 Ref

+0 Will +0; AL: N] [Mutant 3 "Asthmatic Annie" (female appears as a PSH in bamboo armor - torso₁, shoulder₁, hip guards₁ - with crossbow): INIT: -2; Atk: auto-reloading crossbow +2 ranged 50/100/150 (1d6), dynamite -2 ranged (d6 Dmg die, 10' blast radius), energy sword -2 melee (2d6); AC: 8 (Armor Die: d5); HD: 9d10; HP: 85; MV: 25'; Act: 1d20 one turn, 1d16 next, then 1d20 again, etc.; SP: Regenerates 2 HP per turn; SV: Fort -4 Ref +0

THE KILLER OF GIANTS

Will +3; AL:N. Asthmatic Annie has an ID Card for Audrey Hallovin, Colonel (Officer)] These mutants are fiercely loyal to one another: they will not betray each other or even talk bad about each other, even in secret.

4. Empty
5. Empty
6. Empty. The door to Platform 2:3 is locked

PLATFORM 2

1. Several mechanical parts lie around the room. A successful DC 12 Intelligence check will show that the parts probably belong to a medical bot. Repairing the bot is a DC 20 task for Tinkerers. The additional reprogramming needed to get it back into full working condition is a DC 20 task, as well. There are 3 hydrogen cells among the pieces, which could be used to power up the bot, if desired. Among its internal med kit are: 4 vials Stim Dose. (When injected, this increases the character's Movement by +50% and allows an extra 1d12 action die per turn for 1d6 turns, then causes the character to pass out for 1d4 turns.), 1 Anti-Radiation Serum (cures 1d10 of Stamina loss due to radiation), and 3 Healing doses (Heals 1d4 HP).
2. This is the decontamination chamber. One door leads to tunnel 2, while another leads to the other missile silo complexes. Upon entry, the doors close and seal shut, a trapdoor slides out and encloses the ladders leading up and down, air hoses hiss, and the pressure in the chamber increases. After one full minute, the doors open, the hoses stop hissing, and pressure in the chamber goes back to normal. Any diseases which might have previously infected those in the chamber are instantly cured. This does not affect chronic or genetic diseases, only bacterial and viral diseases.
- 3 Empty.

CONTROL CENTER:

1. Contains a bunk bed, lockers, a bathroom, and other mechanicals. There are some old photographs of pure strain humans, some clothing, and a stim dose. Bedding is still on the beds, with a skeleton under the covers of each bed. Each is fully clothed

and has a military ID in its pocket ("Captain Maria Rogers (Officer)" and "Lieutenant Simlin Foxworthy (Officer)"). The clothing, all of it in military drab green, is in excellent condition. In the lockers are: 1 assault rifle with 2 magazines of 30 bullets each, 1 frag grenade, 2 Anti-radiation doses, and 2 daggers.

2. The power is on in this room. Lights blink, indicators give readouts, gauges move – everything is working. If a person tries to determine how the systems work, make a DC 10 Luck check. Failure results in a klaxon sounding, with all lights shutting off except for a red flashing light. Though the language is indecipherable, a voice comes over the speakers located in the ceiling and proceeds to count down from "T-minus 10". When the count reaches 0, the whole complex rumbles and shakes – the missile in the silo has launched! Thick black smoke will fill any open areas, asphyxiating anything in those areas. Only one closed blast door is needed to keep the smoke out. A monitor will show a video feed of the missile launching, and remote cameras will catch the warhead's detonation. The area destroyed should be familiar to the party's characters – their home village, a local landmark not too distant, etc. An escape hatch, locked, leads to the escape tube.
3. This room is full of mechanicals, but is otherwise empty. An escape hatch (unlocked) leads to an escape shaft that leads to the surface.

WANDERING MONSTERS

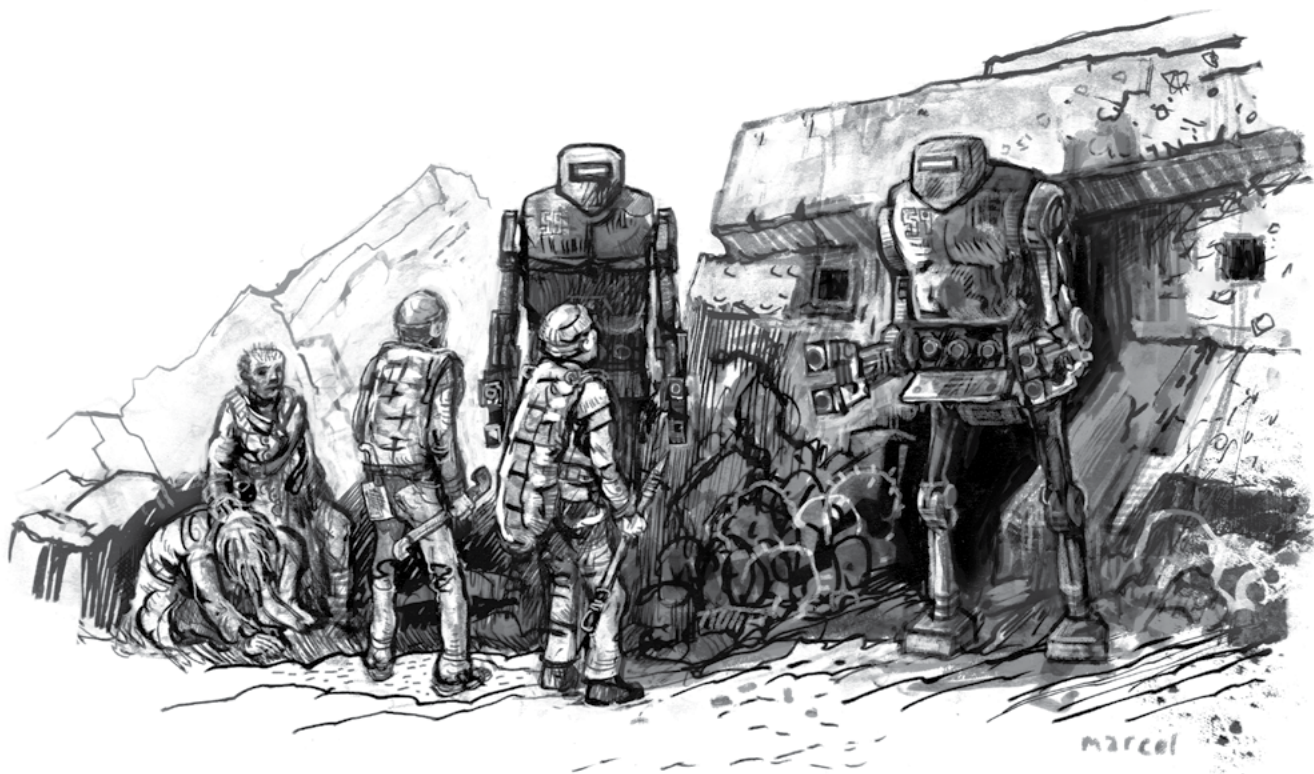

WANDERING MONSTERS

Every half hour of real time (not in-game time), roll a d6. On a “6”, a wandering monster is encountered. This may interrupt an interaction in-progress or may present the wandering monster in the most unlikely of places. The encounter should be integrated as seamlessly as possible into existing circumstances. For instance, a school of Skyranha might appear in a building through a previously-unnoticed hole in the ceiling, or the booming steps of the Giant Mosquito might flush them up from a place where they were resting under a tree, etc.

When an encounter is indicated, roll 1d6 and consult the following table for the result. Results may be repeated.

1. School of 3d8 Skyranha [**Skyranhas**: INIT: +5; Atk: Bite +1 melee, 1 HP damage; AC: 10; Armor die: nil; HD: 2 HP each; MV: 30'; Act: 1d20 each; SAVE Fort +0, Ref +0, Will +0; AL: C]
2. Indrid Cold, a 6' 6" gaunt looking man (?) with tiny ears and almost no nose, whose grin splits his face all the way across. He will appear as if from nowhere, found casually leaning against a wall where nothing was there mere seconds ago, or turning to face the party from a chair that was empty when they blinked a moment ago, etc. He is not aggressive, but sits or stands, arms folded, observing the party and asking strange questions that make it obvious that he is not “from around here,” such as: “Do people live over in that building?” or “Is it day or night?” or “How many fingers do people have around here?” He will not answer questions, merely grinning at the interlocutor, but will reward answers to his questions with a polite “thank you.” If attacked, he seems to disintegrate; but he may pop up as a random encounter later on. He will continue asking questions and following the party until attacked.
3. A stray puppy that somehow made it out of the dog kennels. The Mutts will definitely try to kill to get it back if they find you with it. They might kill you anyway, even if they don't find you with it.
4. A Mandroid on patrol [**Mandroid**: INIT: +3; ATK: Subdual Martial Arts +3 melee (1d4+3 subdual damage only); internal taser (1d6 subdual damage plus make a DC 18 Fort save or pass out for 1d4 turns); AC:13; Armor die: [1d8]; HD: 4d10; HP: 26 each; MV 30'; Act: 1d20; SP: Infravision 60', immune to mind-altering spells, heal 3 HP per turn; SV: Fort +5, Ref +3, Will +6, AL:N]

WANDERING MONSTERS + AFTER THE ADVENTURE

5. A pair of Soil Seers, emerge from the earth and run at top speed for a nearby hole in the ground. The Soil Seers, hole, and party form a perfect equilateral triangle, 30' on a side [**Soil Seers:** INIT: 0; Atk: Appendage +0 melee (1d4 + visions of being buried alive); AC: 10; Armor die: 1d2; HD: 2d8; HP: 12 each; MV: 20'; Act: 1d20; SP: Buried Alive! SV: Fort 0, Ref 0, Will +4; AL:N]
6. A security bot, on patrol, demands to see ID cards from all party members. If none are shown, it will attempt to subdue and arrest those who don't possess them. If attacked, it will use deadly force. If it successfully subdues those it doesn't kill, it will stand by for further orders (which will never come). Very unusual or clearly illogical behavior on the part of prisoners will cause it to short circuit, after manifesting small sparks and puffs of smoke. The Judge should . . . erm, judge how long this takes and how much ridiculousness needs to be made manifest [**Security Bots:** INIT: +5; Atk: Stun whip melee +6 (stun for 1d6 turns, successful DC 15 Fort save halves duration, paralysis dart missile +4 (Paralyze for 2d6 turns, successful DC 16 Fort save halves duration, Gauss Gun missile +6 (5 shots/turn, 1d10+2 damage/shot – super-high-velocity tungsten needles. Robot holds 60 ammo), zip ties melee +10 (hands or feet are tied behind targets back with high-strength plastic zip ties that must be cut to loose); AC: 15; Armor die: [1d4]; HD: 5d12; HP: 60 each; MV: 40'; Act: 3d16; SP: Force field, unaffected by spells that affect the mind; SV: Fort +10, Ref +5, Will +0; AL: L]

towns and villages in surrounding areas or areas far from the base. Hofstadter II provides a quick way to set your adventurers down wherever you want them – and possibly where they want to go! Perhaps P.E.T.A. is a larger organization, with Boss Faugnar and his gang only a small portion of a greater conspiracy to rule Urth.

There are many groups that have converged and are converging on the base. Where did the Fewhines come from and where are they going? And what will happen when petrolheads across the land hear about the transportation building? Surely, if one waits long enough, other groups will come snooping around the base.

But will your party of adventurers want to be there when they arrive?

As was stated at the beginning, the intention of Killer of Giants is to be a beginning, not an end.

Go. Explore. Urth is before you. *Ride!!!*

THE ROAD AHEAD: AFTER THE ADVENTURE

A campaign can take off in any number of directions from the encounters presented here at the base. If the Gray gets away, it can provide a compelling, recurring villain to set against the party. No doubt it has the intelligence and wherewithal to leverage its considerable knowledge and the rich supply of technological resources on the base. The Soil Seers tunnels can provide an almost unlimited scope of underground adventures. If encountered, Indrid Cold could also prove an interesting foil for the party. Who is he? Why does he ask so many questions? What is he trying to do? Needless to say, if a nuclear launch occurs, this can have far-reaching consequences for

Product Identity: The following items are hereby identified as Product Identity, as defined in the Open Game License 1.0a, Section 1(e), and are not Open Content: All trademarks, registered trademarks, proper names (characters, deities, etc.), dialogue, plots, storylines, locations, characters,

artworks, and trade dress. (Elements that have previously been designated as Open Game Content are not included in this declaration.)

Open Content: Except for material designated as Product Identity (see above), the game mechanics of this fanzine are Open Game Content, as defined in the Open Game License version 1.0a Section 1(d). No portion of this work other than the material designated as Open Game Content may be reproduced in any form without written permission.

OPEN GAME LICENSE Version 1.0a

The following text is the property of Wizards of the Coast, Inc. and is Copyright 2000 Wizards of the Coast, Inc ("Wizards"). All Rights Reserved.

1. Definitions: (a) "Contributors" means the copyright and/or trademark owners who have contributed Open Game Content; (b) "Derivative Material" means copyrighted material including derivative works and translations (including into other computer languages), potation, modification, correction, addition, extension, upgrade, improvement, compilation, abridgment or other form in which an existing work may be recast, transformed or adapted; (c) "Distribute" means to reproduce, license, rent, lease, sell, broadcast, publicly display, transmit or otherwise distribute; (d) "Open Game Content" means the game mechanic and includes the methods, procedures, processes and routines to the extent such content does not embody the Product Identity and is an enhancement over the prior art and any additional content clearly identified as Open Game Content by the Contributor, and means any work covered by this License, including translations and derivative works under copyright law, but specifically excludes Product Identity. (e) "Product Identity" means product and product line names, logos and identifying marks including trade dress; artifacts, creatures, characters, stories, storylines, plots, thematic elements, dialogue, incidents, language, artwork, symbols, designs, depictions, likenesses, formats, poses, concepts, themes and graphic, photographic and other visual or audio representations; names and descriptions of characters, spells, enchantments, personalities, teams, personas, likenesses and special abilities; places, locations, environments, creatures, equipment, magical or supernatural abilities or effects, logos, symbols, or graphic designs; and any other trademark or registered trademark clearly identified as Product identity by the owner of the Product Identity, and which specifically excludes the Open Game Content; (f) "Trademark" means the logos, names, mark, sign, motto, designs that are used by a Contributor to identify itself or its products or the associated products contributed to the Open Game License by the Contributor (g) "Use," "Used" or "Using" means to use, Distribute, copy, edit, format, modify, translate and otherwise create Derivative Material of Open Game Content. (h) "You" or "Your" means the licensee in terms of this agreement.
2. The License: This License applies to any Open Game Content that contains a notice indicating that the Open Game Content may only be Used under and in terms of this License. You must affix such a notice to any Open Game Content that you Use. No terms may be added to or subtracted from this License except as described by the License itself. No other terms or conditions may be applied to any Open Game Content distributed using this License.
3. Offer and Acceptance: By Using the Open Game Content You indicate Your acceptance of the terms of this License.
4. Grant and Consideration: In consideration for agreeing to use this License, the Contributors grant You a perpetual, worldwide, royalty-free, non-exclusive license with the exact terms of this License to Use, the Open Game Content.
5. Representation of Authority to Contribute: If You are contributing original material as Open Game Content, You represent that Your Contributions are Your original creation and/or You have sufficient rights to grant the rights conveyed by this License.
6. Notice of License Copyright: You must update the COPYRIGHT NOTICE portion of this License to include the exact text of the COPYRIGHT NOTICE of any Open Game Content You are copying, modifying or distributing, and You must add the title, the copyright date, and the copyright holder's name to the COPYRIGHT NOTICE of any original Open Game Content you Distribute.
7. Use of Product Identity: You agree not to Use any Product Identity, including as an indication as to compatibility, except as expressly licensed in another, independent Agreement with the owner of each element of that Product Identity. You agree not to indicate compatibility or co-adaptability with any Trademark or Registered Trademark in conjunction with a work containing Open Game Content except as expressly licensed in another, independent Agreement with the owner of such Trademark or Registered Trademark. The use of any Product Identity in Open Game Content does not constitute a challenge to the ownership of that Product Identity. The owner of any Product Identity used in Open Game Content shall retain all rights, title and interest in and to that Product Identity.
8. Identification: If you distribute Open Game Content You must clearly indicate which portions of the work that you are distributing are Open Game Content.
9. Updating the License: Wizards or its designated Agents may publish updated versions of this License. You may use any authorized version of this License to copy, modify and distribute any Open Game Content originally distributed under any version of this License.
10. Copy of this License: You MUST include a copy of this License with every copy of the Open Game Content You distribute.
11. Use of Contributor Credits: You may not market or advertise the Open Game Content using the name of any Contributor unless You have written permission from the Contributor to do so.
12. Inability to Comply: If it is impossible for You to comply with any of the terms of this License with respect to some or all of the Open Game Content due to statute, judicial order, or governmental regulation then You may not Use any Open Game Material so affected.
13. Termination: This License will terminate automatically if You fail to comply with all terms herein and fail to cure such breach within 30 days of becoming aware of the breach. All sublicenses shall survive the termination of this License.
14. Reformation: If any provision of this License is held to be unenforceable, such provision shall be reformed only to the extent necessary to make it enforceable.
15. COPYRIGHT NOTICE

Open Game License v 1.0a Copyright 2000, Wizards of the Coast, Inc.

Dungeon Crawl Classics Role Playing Game Copyright 2012, Goodman Games

UXo2: Mind Games Copyright 2016, Shield of Faith Studios, LLC

American Survival Guide Copyright 2017, Shield of Faith Studios, LLC

Killer of Giants Copyright 2018, Shield of Faith Studios, LLC



IT'S A FREE-FOR-ALL POINT CRAWL!

The protections surrounding an ancient military base, home to the fabled "Killer of Giants", are down! The denizens of Umerica have flocked to the base to grab what they can and establish dominance over this post-apocalyptic treasure trove. Why let everyone else have all the fun? Your party of daring adventurers will discover:

- Dozens of detailed encounters to test (and kill) the most hardy adventurer.
- Several new creature types, including (but definitely not limited to) the sly Vulpes, scaled Salmen, dreaded Soil Seers, deadly Tri-eye-dra, vicious Skyranha, and the horrifying Shockroach!
- Tech, tech, and more tech, from Cheesy Whizzer fake cheese spray™ to the Killer of Giants, and just about everything in-between . . . or at least a representative sample.
- Killer of Giants is usable in your existing campaign or as the jumping-off point for any number of long-term campaigns. It's an incubator of ideas for longer story arcs (some assembly required)!

This product is compatible with the
Dungeon Crawl Classics Role Playing Game

\$11.99 CUBM5011

**CRAWLING
UNDER A
BROKEN MOON**



COMPATIBLE WITH
**DCC
RPG**

crawlingunderabrokenmoon.blogspot.com

