

**TWO  
HOUR  
TALES**



COMPATIBLE WITH  
**DCC  
RPG**

Let's Be **BAD** "Guys"

# Pirates



A nautical 0-level adventure  
for Dungeon Crawl Classics  
from Goodman Games.

**Quick**  
  
**Crawls**



# LET'S BE BAD GUYS: PIRATES

A Level-0 nautical adventure

Wherein the PCs decide that they aren't good people...

Written by: Christophor "Dread Pirate" Rick & Michael "Sea Dog" Spredemann

Edited by: Christophor "Crow's Nest" Rick

Ship Map: Domille's Wondrous Works

Lostport, Sereneco, Open Water Maps: Christophor "The Navigator" Rick (Via Inkarnate.com)

Playtesters: Michael Spredemann, Jim Meyers, Jasmine Schmidt

## CONTENTS

INTRODUCTION	1
THE STORY	1
THE QUEST	1
CHARACTER CREATION	1
SCENE 1: AIMIN' TO MISBEHAVE - 30-75 MINUTES	1
SCENE 2: THE SHIP JOB - 45-60 MINUTES	4
THE SERENECO CARGO	5
THE SERENECO WATCH	5
THE SERENECO	5
SCENE 3 OBJECTS AT SEA	5
THE SOFT TARGET	6
THE HARD TARGET	6
WRAPPING UP THE ADVENTURE	7
FURTHER ADVENTURES!	7
APPENDIX E: ENEMY SAILORS	8
SOFT TARGET SAILORS	8
HARD TARGET SAILORS	8
APPENDIX O: OCCUPATIONS	9
APPENDIX R - REFERENCE CARDS	10
APPENDIX S: THE SERENECO CREW	13
APPENDIX V - VTT TOKENS & MAPS	16
THE SERENECO	17
LOSTPORT	18

COMPATIBLE WITH  
**DCC  
RPG**

*This product is based on the Dungeon Crawl Classics Role Playing Game, published by Goodman Games. This product is published under license. Dungeon Crawl Classics and DCC RPG are trademarks of Goodman Games.*

*All rights reserved. For additional information, visit [www.goodman-games.com](http://www.goodman-games.com) or contact [info@goodman-games.com](mailto:info@goodman-games.com).*



Let's Be Bad Guys: Pirates, Two-Hour Tales, and Quick Crawls are productions of

2 Old Guys Games, LLC © 2020.

All rights reserved. First Printing.

Visit [2oggames.com/shop](http://2oggames.com/shop) for other products and information.



## Introduction

We at 2OG games love a good nautical adventure. We even successfully Kickstarted a big, gonzo funnel called [Sinking the Stercorarius](#). We realize that some people may not be into that sort of weird genre-bending story and simply want something... else. So, we have taken pieces of some things we've written and we've turned it into a different sort of funnel. In this adventure we'll make characters with piratical tendencies, send them out to secure a ship, and then sail that ship into some further action. It's only a wee bit gonzo since the ship is akin to an old Spelljammer.

## The Story

A crew has been assembled for a grand theft nautical scheme. You're all crew, no ship and maybe no captain. The crew decided the best way to get more fame and fortune is to simply...steal a ship. Now, no pirate worth their salt would break The Pirate Code and steal from other pirates. So, you have decided to steal a ship that is not property of a pirate, and there's just such a ship anchored in the harbor today, The Sereneco!

## The Quest

The first step is **GATHER INFO & MAKE A PLAN**. Get to the ship, steal the ship, get out to sea, take your first prize. Huzzah! You're Pirates now! Unless you're dead, then you might be warriors in the undead army of the Sea Witch, or Umwansh Lord of the Tides or Pelagia, Queen of the Seas... but that's another adventure and another story.

## Character Creation

Included in this adventure is an occupations table ([Appendix O](#)) from our [Pirate expansion](#) for *Sinking the Stercorarius*. Create 4 PCs per player as usual for a DCC funnel, and when you get to occupations, use our table. Otherwise, character creation is as written in the DCC rulebooks. For part of the adventure some of the crew might be off gathering supplies and each player might just control 1-2 main PCs each.

**Judge Info:** *The nautical life is a tough one. Perhaps put a lower limit of 6 on ability scores...or not.*

## Scene 1: Aimin' to Misbehave - 30-75 minutes

*Arr! Mateys. It be time to strike out on our own and set course for fame and fortune! What say ye scurvy sea dogs ta' stealin' a ship of our own?! YARRR! Let's get to this Grand Theft Nautical then! First off, who's got a plan? We'd best make one quick!*

This scene is all social and some exploration as it revolves around the crew planning to steal the ship. We've already got the ship picked out, The Sereneco, a Caravel-like ship that had some trouble on the way to the town (Lostport if you need a name. It's like the dive bar of ports in the region, scum and villainy and all that). They limped in and have just finished repairs, but the captain hasn't begun recruiting new crew due to the cost, allegedly. Let the PCs

figure out how they want to proceed. There is little in the way of information about the Sereneco and its crew, just what is below. The PCs might also do well to set a stakeout on the ship to watch the crew's comings and goings, maybe get an idea about their schedules and habits, etc. Offer those tips if they get stuck.

**Judge's Note:** *This section of the adventure should take about 30-45 minutes of social, exploration, and planning. After that time, they should have a plan formed and be ready to implement it. However, some of the PoI below can derail that timing. See play-test note below.*

## Steps: Investigate - Formulate Plan - Execute Plan

### Places of Interest

**The Crusty Pangolin** – Allegedly, the only reputable inn. One in a chain of establishments throughout the realms. It's a franchise, but they have a solid set of guidelines so that the experience in any Pangolin is equal to all the others. They all use the Pangolin name but can vary it with a single descriptor. However, the layout of the building is the same in every location and the license owner, Reybold Brandala shows up to get new owners up and running and show them the ropes of being a Pangolino. All the Pangolin locations have a big common room with a large hearth, bar, and tables, comfy chairs and seats at the bar. All Pangolino are expected to brew or ferment something on site. Upstairs, the Pangolin has 6 spartan but comfortable rooms with two beds per room. Prices are set out in the Pangolino Operations Guide and allow a small variance for local exchange and market rates. They usually land about average in terms of cost for food, drink, and lodging. There is never a stable as Reybold believes that a local business should breed other local businesses and thus he leaves that niche to others. The Crusty Pangolin is run by Pangolino Patience (below).

**Niska's Needed Things** – You need things, Niska has them. However, getting them from Niska always takes some work as he seems uninterested in selling most things he has in his shop, and there's a lot of things. Asking around will get information about Niska and his extremely strict code of conduct. The shop is unusually well-stocked and holds a wide range of useful items magical and mundane. Anything on a mundane equipment table might be found here along with potions of various kinds (1<sup>st</sup> level spell effects or healing up to 2HD). Additionally, at the Judge's discretion, some other magical trinkets might be found, though at a premium price. The store is oddly arranged. When one enters, they are inside of a long cage that goes from door to back of the store. On a dais in the back of the store is a large desk and behind that desk sits Niska. He is able to walk out from behind the desk and along the top of the cage as well as along other racks of equipment. He asks odd prices for his wares, like a book written by the PC and a vial of their blood, etc.

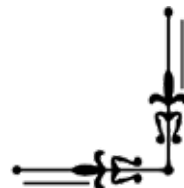

**Hoban's Haven** – Hoban's is an oddly named religious supplies store. Even more odd is the fact that it's in Lostport which is about as far as one can get from a righteous, religious-based existence. So, what is Hoban hoping to accomplish with their Haven? One need but ask them and they shall expound upon it, ad nauseum. Entering Hoban's Haven is not unlike entering a temple to a goddess of calm and serenity. Airy, light music plays from no particular place and the quality of the light is soothing and peaceful. The air is cool and refreshing. Scents float on the air based on Hoban's mood that day and can be a brisk smell of sea salt, a forest just after a light rain, fresh-baked bread, lavender and chamomile, eucalyptus and spearmint, or a rather light and pleasant mix of citrus.

### **People of Interest**

**Pangolino Patience** – Lived a hard life, as evidenced by her numerous scars, two missing fingers on her right hand, and her glass eye. If one asks her, she says it was a fermentation accident, but the real story is that she sailed as one of the most feared pirates of the Wizard Sea. That sea is far away, and she seems quite content with her running of the Crusty Pangolin as a lifestyle choice. Then again, others say she is the head of the whole black market in the region, but she hides it as it brings trouble, and could be a violation of her franchise agreement. Noone really knows except Patience.

**Niska Nunya** - /nee-ska/ Niska is not from around here, which seems to be a trend in business owners in Lostport as if they are all running from something. However, meeting Niska makes it hard to believe this grizzled, gnome (?) runs from anything. Though small in stature, he is fierce in his business dealings. He does not deal in coin stating "the arbitrary value of coins made in meaningless realms or cities are of little worth to me." In fact, he only barter for things in his shop. The two triggers for a successful deal with Niska are either something he has never seen before, or something that is of equal value in terms of condition and usability. How he determines value in that second possibility is up to the Judge.

**Hoban Zoeburne** – "Greetings, lost ones," is often how Hoban greets those who enter their Haven. Whether they speak about the visitors' life choices or have simply given that affectation to those living in the city remains to be seen. Hoban stares into people, not at them. As soon as they turn their gaze onto someone, they seem to know more about them than anyone should know, as if reading the map of one's soul. In fact, the tone of light and scent of the air becomes tailored for each person that Hoban affixes with their stare. An eerie stare it is, as Hoban's left eye is entirely black while their right eye is entirely white. Their skin is light, almost as if covered in dust or flour. Their hair is light blonde, almost translucent and they are tall and thin, even by Elven standards. Hoban wears a robe of swirling shades of gray, but no one is certain if it is magic or a very strange fabric.

If asked about why the Haven is here, Hoban will begin talking about how no place in the universe is any differ-

ent than any other and that The Haven may very well be everywhere at once. That is the nature of the quantum cosmic balance, is it not? When one enters the Haven, was the Haven where they were, or was the door simply a portal that brought them to the Haven's location? If the Haven is, in fact, everywhere all the time, then from where you entered is irrelevant because the Haven is everywhen and where. Hoban will go on to ask who are they to decide that one location in the multiverse is better or worse than another? That is an application of a belief system that does not pertain to all parts of the multiverse and therefore is also, irrelevant. Hoban sums it up with, "In other words, it matters not where you entered from, only that you are now here and that means you must require my assistance in some way, so how can I help you?" Judge's discretion on inventory.

**Playtesting:** *Niska's and Hoban's can be really strange places as Niska is sort of like a mix of supernatural mobster and the devil offering things the player might need, even if they don't work exactly as expected. I whipped up a magical bow, globe of sleep powder, and some dainty gloves of smashing. The special abilities often pop off when a Luck check is successful. Hoban is a strange mystical otherworldly presence who talks in riddles but can be truly helpful and may have useful potions, advice, etc. Have fun with this. However, note that it took A LOT OF TIME. In fact, I think that if you want the quickest path possible, don't mention Niska's or Hoban's as both can turn into a 30-60 minute thing. If you've got 3-4 hours, then have fun with them!*

**On planning:** *We set the scene "you want to steal a ship, you've picked a target, what's the plan?" But you may have to restate that to keep the PCs on track regarding time. There's little information available about the ship as the crew purposely does not leave the Sereneco to avoid complications. They don't allow anyone on board for the same reason. They made repairs and are awaiting the cargo they are to take somewhere else.*

*The PCs will have to gather any information they want. Some can be done in the Crusty Pangolin by having dock workers who delivered supplies be there and ready to chat. The other way is the old fashioned, go out and investigate, way. While this is a funnel and you CAN streamline it to 2 hours, it could also be expanded to 4-5 hours by simply delving into some details.*

### **Information impossible to get:**

- Anything about the crew or where the Sereneco is from.
- What they're doing aside from repairs.

### **Easier to obtain by observation:**

- The daily watch schedule (# on watch, length of shift, etc).
- The ship's basic construction (but not how it works).
- The number of crew (they all remain fully covered on deck).
- Entry points on the ship (hatches, nets, carvings, etc).

**The keys to a successful assault here are information, assets, and planning.**



## Stories of Interest

### Stories about the town

- The town was allegedly organized by Patience and Niska who arrived from elsewhere which may have been on the Wizard Sea. Perhaps they were in dire trouble or perhaps, they tired of whatever life they were living. From them the place grew... or so they say.
- Patience is said to have killed the king of some realm no one can remember and that king's daughter, who became queen, is searching for her and will pay anyone their weight in diamonds if they bring Patience to her.
- Hoban is believed to be a being from another plane of existence, perhaps even an avatar of one of the great lords of Neutrality who watch over the Cosmic Balance.
- The town was allegedly founded on the shore when the Pirate King lost his entire fleet to the Sea Witch. Those that survived swore they would never again set foot on a ship and have taken to a life anchored on the shore. Many residents look like they may have been party to some plundering and Pillaging but won't leave land.
- Out in the bay, under the Black Moon, the water churns as the dead rise from their watery grave and reach out to claim any life they can hold. But no one has lived to say whether that is true. The Black Moon is fast approaching!
- The town was allegedly founded after a great battle between Umwansh Lord of the Tides and Moerg Lord of the Mountains, by those who were left to fend for themselves after the Elemental Lords took their war elsewhere. They clashed as each sought to dominate a portion of the other's domain out in the Elemental Planes, but the war spilled over onto this plane and the odd shape of the bay and the nearby mountains is left over damage. The bay has strange rocky outcroppings in it that are dangerous to pilot around if one does not know the proper approach. The mountains have large sections that are missing from their bases. There are awe-inspiring or mind-boggling overhangs where rock juts out over empty space sometimes as far as 400 feet! It almost looks as if something took a swipe at the mountains and erased part of them.

*Playtesting: I used these as stories in the Pangolin or from locals, drunk or eccentric dock workers, etc. Some are meant to be contradictory. None in town, save the crew of the Sereneco, know its story, origin or mission. Someone might know the true origin of the town, it could be one of the stories above or something completely different, your call.*

*Judge's Note: The Black Moon is meant to fall around Halloween. It could be that the Sea Witch's Undead Armada arrives and raises the dead from their watery graves. See The Village of Death, set to publish mid-October, 2020.*

## The Sereneco Story

The Captain and just eight crew were on the ship when it limped into the bay and anchored there to manage repairs. A ship that size would normally have a crew between 15 and 25. Rumors abound, but the most popular one is that the Sereneco is from somewhere else, as in, some other plane. While it sounds like nonsense, there are certain things about the ship and crew that lend credence to that rumor. They are all humanoids of various types but only one has stepped foot off the ship, the Quartermaster (see below). The ship has sails, but they fold and unfold and look more like fins on a fish or wings of say, a dragon? The Captain would not allow anyone on board to do repairs, they ferried supplies out and the crew did all the work on their own. Very little is known about the ship itself and just as little is known about the crew aside from the one person sent to get provisions and supplies for repair.

### The Quartermaster

The Sereneco's quartermaster, Vaush, is a burly sort. Thick arms and legs and a stout body see them towering over most others in the town. While they generally kept their hood up, some believe Vaush to have the face of a bear, or a mix of bear and man. Vaush's hands remained gloved and his entire body covered in clothing and cloak when in town purchasing supplies, so no one is quite sure. But those who were curious enough to get close swear that Vaush is some uncommon stock.

### The Plan

Some things the PCs might want to think about as they create their plan. How are the PCs getting out there? Swimming? Rowing? Some other way? Are they going to kill the crew or overpower them? Can they operate the rigging of such a strange ship? Is the ship ready to set sail?

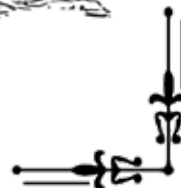



## Scene 2: The Ship Job - 45-60 minutes

With plan set, you're ready to take your first steps toward being pirates! The *Sereneco* is minimally crewed. Something happened to them on the way to [Lostport] so when they arrived, much of the crew was missing. Those eight that remain are steadfastly loyal to the Captain, mostly. Now, the question is, will fate cooperate or work against you?

**Judge:** It's time to steal a ship! Will they attack during the day (daring!) or at night (stealthy!). Weather could play a big role so here's a quick weather chart. You can pick the season randomly or choose the one that fits where you want to take your game, we suggest autumn to coincide with the Black Moon. There are day and night options. The bonuses only apply to the nighttime weather below. The wind could affect ranged weapon attacks if you want to make things more challenging.

When the PCs are ready, determine the day's weather below.

### WEATHER CHART

1d4 season 1d8 details	Winter	Spring	Summer	Autumn
1-2	Sunny/clear/Bright moonlight	Sunny/clear/Bright moonlight	Sunny/clear/Bright moonlight	Sunny/clear/Bright moonlight
3-4	Partly cloudy/dim moonlight (+1 to stealth/hide)	Partly cloudy/dim light (+1 to stealth/hide)	Partly cloudy/dim light (+1 to stealth/hide)	Partly cloudy/dim light (+1 to stealth/hide)
5-6	Cloudy/almost dark (+2 to stealth/hide)	Cloudy/almost dark (+2 to stealth/hide)	Cloudy/almost dark (+2 to stealth/hide)	Cloudy/almost dark (+2 to stealth/hide)
7-8	Snowy 1d4 1-light 2-medium (+2 to spot tracks) 3-heavy (-5' movement) 4-blizzard (-2 all rolls outside, -10' movement)	Rain 1d4 1-drizzle 2-steady 3-hail 4-torrential (-3 to all attack rolls, +2 to all stealth and hide rolls)	Rain 1d4 1-drizzle 2-steady 3-heavy 4-deluge (-3 to all attack rolls, +2 to all stealth and hide rolls)	Rain 1d4 1-drizzle 2-steady 3-hail 4-sleet (-10' movement, -2 attack rolls, -4 climb, +2 stealth/hide)

<b>Wind 1d8</b>	1-3 - Calm 4 - Light 5 - Strong	6 - Gale Force (-4 ship piloting, -4 ranged attacks) 7 - Storm (-6 ship piloting, -8 ranged attacks) 8 - Hurricane! (Direction applies to if the storm is coming in or heading out, tie yourself down and hope for the best!)
<b>Direction 1d8</b>	1 - N 2 - NE 3 - E 4 - SE	5 - S 6 - SW 7 - W 8 - NW

For more in depth wind effects see the [Beaufort Scale](#).

Once the weather is determined it will either help or hinder the PCs and NPCs. You can give the PCs an idea of what the weather is for the day/night they choose to steal the ship and they can form their plan.

The weather conditions will affect everything from their initial approach to the fight for the ship to their fleeing from the harbor. Granted, there's no well-trained and ready naval militia in this town, that's why they started here. In fact, there's barely even a land-based militia and is more about private guard groups watching over the goods of whomever pays them. If they don't like the weather, they could always push off to another day, but the longer they wait, the more chance of them hiring crew and taking on cargo which complicates things (see below).



## The Sereneco Cargo

The Sereneco runs very special cargoes from time to time. In fact, it may be that they've already secretly loaded a cargo onto the ship as the cargo's buyer and seller like things to be done quietly. Now if the PCs steal the ship, they're also stealing the cargo of some very powerful people. The question is, do they steal it before, or after the cargo was loaded on. Each day the PCs wait for better weather or more information, **roll d100** to see if cargo was loaded. On the first day it's a 40% chance, and the chance rises 20% each additional day if it has not been already loaded. Once the cargo is loaded, the Sereneco leaves in 1d3+1 days.

## The Sereneco Watch

With just nine crew members, the Sereneco is on a very limited watch rotation. To ensure that two crew are always awake and on duty they have gone to a four-watch system with six-hour shifts.

1<sup>st</sup> watch 00-06hrs – Quartermaster, Engineer

2<sup>nd</sup> watch 06-12hr – Striker, Ascetic

3<sup>rd</sup> watch 12-18hrs – First Mate, Surgeon,

4<sup>th</sup> watch 18-00hrs – Master Gunner, Musician

The Captain keeps odd hours, roll d100. Over 50 he is awake, otherwise he is sleeping in his quarters.

See Appendix S for more details on the crew.

**Judge:** *Stealing the ship and escaping with it could be the end goal of this adventure. However, we always offer a third scene. We've re-purposed an open water capture scenario below. It's a drop in scenario that could be used at any time during the PCs nautical career with minor modifications.*

## The Sereneco

The Sereneco sails fast and travels light. Most of the armaments are defensive in nature. Chain shot to tear through masts and crew instead of large, heavy cannonballs to sink enemies. There are no broadside cannon, but there are chase cannons fore and aft, two each port and starboard. They're smaller, lighter cannon that can be loaded and aimed quickly. See rules in the next scene on their use.

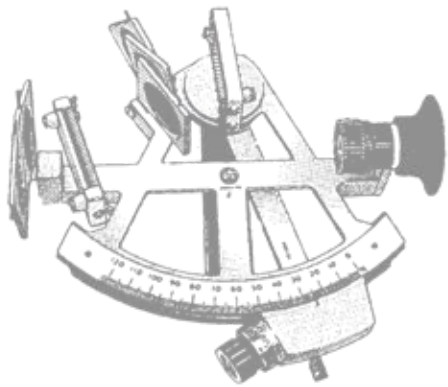

## Scene 3 Objects at Sea

*The watch sees a ship sailing fast at a line perpendicular to the Sereneco. It looks like it might really be the crew's lucky day. Stealing a ship and capturing a prize all in the same day? YAARRR!*

Give the PCs on watch a chance to find a soft target with a Luck check. If they fail, they find a hard target that may be more trouble than it's worth.

If the new crew of the Sereneco has gunners, they can fire the small cannon at the target before boarding. There are 2 small cannon on each side of the ship at the front and the back. They fire chain and bar shot that do not sink other ships but do damage to prevent continued pursuit, as it's a smuggling vessel. Using them to slow and board an enemy ship is a good re-purposing of them. Gives a bit of a chase scene element.

Roll an attack against the enemy ship as DC 14 AGI for the gunner. On a hit, the gunner then makes a Luck roll. On a success, the hit kills 1d3+1 enemies. On a failure, it kills just 1 enemy. Four hits slows the enemy ship to half speed, eight stops it dead in the water.

Pilots can make move checks to get a +2 to hit, or +2 to the DC of the AGI check for opposing cannon.

Things for PCs to do during battle if not a pilot or a gunner:

- Firefighting.
- Weapons should be readied.
- Sand should be spread on the main deck both to fight fires and to absorb blood from battle to keep it from getting slick.
- Buckets of water should be prepped for firefighting.
- Reloading cannon, in reality takes minutes, with 3 crew per gun it takes 3 rounds. One DC 12 AGI each PC.
- Targets will not have cannons on them because they are focused on speed. However, they may still fire flaming arrows, magic, or simply throw torches at the Sereneco when close enough.
- Because of the small size of the cannon, position makes little difference in the damage and effect of the shots from the Sereneco.

**For more complex, yet still modular and light, naval combat rules see 2 Old Guys Games' [Rules of Engagement](#) product available on DrivethruRPG.**

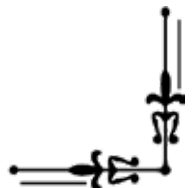

## The Soft Target

A trader on a spice run full to the brim with things easily sold in almost any port without many questions, and a smaller detail of fighting sailors. Hand-to-hand combat of this nature is difficult and dangerous. There are no rules of engagement and nothing to prevent one person from killing an enemy engaged with someone else. These are not well-trained fighters but could still overtake the crew in ten rounds or less. If things look grim, suggest the PCs cut ties with the target and retreat. The Sereneco will outpace this ship, and retreat is quick.

**SAILOR (2, PLUS 3 FOR EVERY 2 PCs):** *Init +0; ATK +1 Dagger/ Club; 1d4 Dmg; AC 10; HP 8; SV Ref +1 Fort +0, Will +0*

**GUNNER (1, PLUS 1 FOR EVERY 2 PCs):** *Init +1; ATK +1 crossbow; 1d6 Dmg; Range 80/160/240 AC 10; HP 9; SV Ref +2 Fort +0, Will +1*

### Booty Per PC

- 25 gp of spices (cinnamon, ginger, saffron, and salt).
- 6 gp of fabrics (samite, wool)
- 1/X<sup>th</sup> of weapons from combatants (X = # of crew)
- 3 silver bars (5 sp each)
- 2 semi-precious gems (5cp each)

The captain gets 3x this, other officers get 2x this. Officers get first choice of weapons from combatants, then the rest gets split across the crew.

**Strategy:** The sailors and gunners aim to not die. If things go extremely poorly, they'll surrender to save their lives and ship, handing over the cargo under a flag of surrender.

## The Hard Target

A trader under contract to a kingdom shuttling troops to a warfront. There will still be some valuable cargo on the ship, but it will be far more difficult to extract. Combat of this nature is brutal. These troops are well-versed in hand-to-hand combat and deadly efficient at their jobs. It is entirely possible that they overwhelm the crew of the Sereneco in a handful of rounds. If things look grim, suggest the PCs cut ties with the target and retreat. The Sereneco will outpace this ship, and retreat is quick.

Two gunners will be in the rigging as snipers with long guns (+3 ATK; 1d10 Dmg; Range 60/120; One shot every four rounds until they are killed.)

**MILITARY (3, PLUS 2 PER PC):** *Init +2; ATK +1 longsword; 1d8 Dmg; AC 12; HP 11; SV Ref +0 Fort +1, Will +1*

**GUNNER (2, PLUS 1 PER PC):** *Init +1; ATK +2 Flintlock; 1d8 Dmg; Range 40/80 AC 11; HP 10; SV Ref +2 Fort +1 Will +1*

## Booty Per PC

- 1/X<sup>th</sup> of weapons from combatants (X = # of crew)
- 8 gold bars (10gp each)
- 7 silver bars (5gp each)
- 1 ruby (10gp)

The captain gets 3x this, other officers get 2x this. Officers get first choice of weapons from combatants, then the rest gets split across the crew.

**Strategy:** See above.

### Notes for either encounter

If all the enemy crew are killed, the PCs may tow the captured ship to port as part of their cut. Use a Dhow or a Luger which were merchant vessels with small crews. However, they'll have to find a piracy-tolerant port and society and the price will be quite low (say 3,000-5,000gp). They certainly can't go back to Lostport just yet. Plus, there's only a 25% chance of finding a buyer of such a noticeably stolen good like a ship.

Also, if they capture a ship, and it has cargo on it, which both targets do, someone might get angry and come looking for it. This could be plot hooks for later stories. Maybe someone recognizes some of the cargo when they try to sell it and either comes after them or sells them out to others who will. See *Further Adventures*, below.

Both targets will have various sundries such as food, fresh water, and standard shipboard supplies. Neither ship carries black powder, cannons or ammunition. Both may have maps or information about other potential targets.

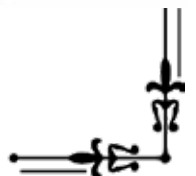



## Wrapping up the Adventure

**Treasure:** The Sereneco is a ship like no other that you've seen. In fact, it hails from another world and has the power to travel between the spheres of reality and ride the void to destinations unknown. The problem is, it's powered by magic and you'll have to figure out what that means. Judge's discretion. While on the PC's world it acts much like a standard sailing vessel. The crew are sailors of some sort and after a bit of practice they get pretty good at sailing it.

If the cargo was loaded in the harbor:

- 50 bars of gold (25gp each) in the Captain's quarters
- 12 crates of cargo full of ???

Allow each player to level up one PC to first level. Keep any others around as crew on the ship. That way it's easy to get reinforcements, or bring in a new PC when one dies.

## Further Adventures!

Someone saw the PCs steal the Sereneco and comes after them to take it back, join the crew, hire them, etc.

The cargo was loaded on the Sereneco and one of the parties involved in the transaction come looking for it. Who that might be, is a mystery.

Someone survives Scene 3 and sends the local Pirate Hunters out to hunt down the pirates (PCs).

One of the cargo owners from Scene 3 is alerted, or spots their cargo in the hands of someone who shouldn't have it. They decide to hunt and kill the PCs as revenge. Or maybe hire them, or trick them... or all of the above.

Their sea-going prowess has attracted the attention of other pirates, factions or entities who have reason to stop, join forces, or avoid the PCs.



## Appendix E: Enemy sailors

### Soft Target Sailors

#### **SAILOR (2, PLUS 3 FOR EVERY 2 PCs)**

*Init +0; ATK +1 Dagger/ Club; 1d4 Dmg; AC 10; HP 8; SV Ref +1 Fort +0, Will +0*

**Strategy:** The sailors and gunners aim to not lose their lives. If things go extremely poorly, they'll surrender to save their lives and ship, handing over the cargo.

#### **GUNNER (1, PLUS 1 FOR EVERY 2 PCs)**

*Init +1; ATK +1 crossbow; 1d6 Dmg; Range 80/160/240 AC 10; HP 9; SV Ref +2 Fort +0, Will +1*

**Strategy:** The sailors and gunners aim to not lose their lives. If things go extremely poorly, they'll surrender to save their lives and ship, handing over the cargo.

### Hard Target Sailors

#### **MILITARY (3, PLUS 2 PER PC)**

*Init +2; ATK +1 longsword; 1d8 Dmg; AC 12; HP 11; SV Ref +0 Fort +1, Will +1*

**Strategy:** These guys will want to fight to the death as a point of honor. They're sort of jerks that way. Plus, they're on a trip to the frontlines of a war for their king. They could be serious problems for the PCs.

#### **GUNNER (2, PLUS 1 PER PC)**

*Init +1; ATK +2 Flintlock; 1d8 Dmg; Range 40/80 AC 11; HP 10; SV Ref +2 Fort +1 Will +1*

**Strategy:** The sailors and gunners aim to not lose their lives. If things go extremely poorly, they'll surrender to save their lives and ship, handing over the cargo.

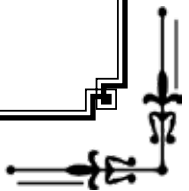



## Appendix O: Occupations

ROLL	OCCUPATION	WEAPON	TRADE GOODS
1-11	Able-bodied Sailor	Tankard (1d3)	Nothing
12	Boatswain	Saber (1d6, AGI)	15' rope, 3 yards canvas, 10' chain
13-14	Cabin Boy	Carving Knife (1d4)	Privy brush, bucket
15	Carpenter	Hammer (1d4)	Saw, 1 dozen nails
16	Cooper	Flagging Iron (1d4)	Cooper's Tools*
17	Doctor/Surgeon†, ††	Clyster Syringe (1HP, DC 15 Sedative, 1 dose)	Surgeon's Kit**, pint of rum
18	Gunner	Handspike (polearm, 10' range, 1d6)	5' fuse, 1lb black powder, botefeux
19	Master Gunner	Bar shot (1d6, melee)	Spyglass, powder vial, 2x Chain shot (1d4, range 15')
20-21	Mate (2nd, 3rd...)	Dagger	Ship's journal, quill, ink pot
22	Musician†	Nipperkin (1HP)	Fiddle, pipes
23	Navigator†, ††	Quadrant (1d4)	Sailing charts, compass, spyglass
24	Pilot	Plumb bob (15' range, 1d4)	Compass
25	Powder Monkey	Unarmed (2HP)	1lb black powder, coil of fuse
26	Rigger	Belaying pin (1d4)	Knife, block & tackle
27	Striker	Spear	Animal hide, net, snare
28-29	Swabbie	Mop (1d3)	Bucket, soap, scrub brush
30	First Mate or Quartermaster ††	Saber, pistol (1d8) and dagger or trident (1d10)	10gp, longcoat (acts as leather armor), good pair of boots, 2 random pieces of equipment from Table 3.4 (page 73 DCC Rulebook)

† Most likely pressed into service or kidnapped. May not necessarily be extremely loyal to the Officers.

†† Usually not more than one of each.

\* Tools necessary to make barrels includes: Heading knife, hammer, flush borer, tapered borer, shave base, shave top, plucker, block hook, bent cooper driver, chincing iron, rivet punches, flagging iron, hoop driver.

\*\* Tools for arrow/bullet extraction, Cauterizing, various syringes, dental instruments and pelicans, dressings, head surgery tools, leeches, various medicines, setons and cauteries, mortar and pestle, straight razors, amputation tools. A portable kit would only contain a plaster box (first aid), a Salvatory (salves and medicines for treating a fresh wound), a pocket toolset (folding lancets, forceps, scissors, seton needle, speculum oculi, tenaculum, uvula spoon)

### Who is the Captain!?

There is no Captain on the table. Someone could petition the crew to be Captain. It means a larger cut of bounty and being responsible for everything. The Captain could be elected from the crew the first time round. Later, they could be challenged to one-on-one combat for the position. As Captain, it's best to kill anyone who challenges your authority in that way, because they will probably try to kill you if you don't. That's what being bad is about.

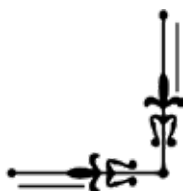

## Appendix R - Reference Cards

### *Vaush /vawsh/*, *The Quartermaster/Pilot*

*Ursine humanoid warrior, Medium*

*Init +1; Atk Saber +3 melee (1d8+3); Claw +3 melee (1d5+3); AC 12; HD 2d8+4 (10HP); MV 30'; Act 1d20; SV Fort +2, Ref +1, Will -1; AL Neutral.*

Vaush is bear folk who grew up in the high wood of Cautheron. Vaush fought in the Green Folk rebellion against the evil lord of Tuboluk and was dislodged from their home plane in the final battles. The Captain found them drifting on the Ageless Sea and took them on as crew. Turned out Vaush was a naturally gifted Aether Sailor and could sail the Aether Winds like no one the Captain had ever seen, as if the ship were a leaf on the wind.

**Strategy:** Vaush is a seasoned fighter and as such will raise the alarm to ensure the entire crew wakes to join the battle. After that Vaush will wade into the battle, first targeting the person that looks most deadly, with saber (1d20) and claw (1d16) attacks each round. A magic user of any kind will be high on the hit list, having had bad experiences with them in the past.

### *Follier /foh-li-ay/*, *The Ascetic*

*Vulpine humanoid cleric, Medium*

*Init +1; Pacifist who does not participate in physical combat; AC 11; HD 2d8 (8HP); MV 35'; Act 1d20; SV Fort +0, Ref +1, Will +3; AL Law.*

Follier comes from the reclusive Sly Tribes of the Steaming Steppes where they study the silent ways of the Vulpine Collectives, each dedicated to understanding of a single aspect of the universe. Follier has scarring marks that, if one were to know of such things, denote that they were a 1st tier master of the spiritual aspect of the universe.

**Strategy:** Follier is a master of psychic combat and defense. However, they are existing in a continual state of crisis at the moment and are unable to bring themselves to attack another living creature. That is, until their life is threatened, then, as a matter of self preservation, Follier will create a mental blindspot that hides them from other living creatures. This is an innate mental ability, not magic.

### *Kitlee, The Engineer*

*Grimalkine humanoid thief, Medium*

*Init +3; Atk Wrench +1 melee (1d4), Claws +1 melee (1d3), Poison Needles +3 ranged (10/20/30' (1d6 dmg), DC Fort 12 vs poison for half); AC 14; HD 2d6+2 (7HP); MV 40'; Act 1d20; SV Fort +1, Ref +3, Will +0; AL Chaos.*

The Engineer, Kitlee, hails from The Technocratic Republic of Grimalkin where the Feline Folk strive to be the most advanced society in the Seven Spheres. The strict class structure places every kitten into a classification based on intense aptitude testing. Kitlee was put into the Aether Sailing Engineering (ASE) program where she failed, miserably.

**Strategy:** Kitlee is not much of a physical fighter. The wrench is always with her, so she swings it as needed. She prefers to stay out of sight and attack from the shadows getting a back-stab bonus on the attack. She is fast and a fast climber (25') because of her claws. If she can get a position above the battle, she will attack with the poison needles (20) stored in a bandoleer.

### *Mental Blindspot - Roll 1d20+5*

1-10 Follier is unable to summon enough willpower to affect anything.

11-13 Follier can hide from 1 living creature they target. The target can do a Will save vs Follier's to see through the blind spot. Failure means the target is unable to mentally process the fact they are present.

14-16 Follier can hide from 1d3 living creatures they target. Targets can do a Will save to see through the blind spot.

17-19 Follier can hide 1d3 allies plus self from 1d3 living creatures they target. Targets can do a Will save vs Follier's to see through the blind spot.

20-24 Follier can hide 1d5 allies plus self from 1d4 living creatures they target. Targets can do a Will save vs Follier's to see through the blind spot.

25+ Follier can hide 1d6+2 allies plus self from 1d8 living creatures they target. Targets can do a Will save vs Follier's to see through the blind spot.



### **Serranus, The Musician**

*Crystalline humanoid, Medium*

*Init +1; Atk Saber +2 melee (1d8+1); AC 11; HD 2d8+2 (9HP); MV 30'; Act 1d20; SV Fort +2, Ref +1, Will -1; AL Neutral.*

While Serranus may look fragile, her crystalline form is rather sturdy. Part of a race of sentient crystals formed by residual magical energy on the Mirror Moor from the Techno-Mage Wars.

**Strategy:** Serranus is more of a diplomat than a fighter but do have a saber that they can swing fairly well. They will target the smaller, weaker looking enemies since they are not the strongest fighter themselves.

### **Oz, The First Mate**

*Canine Humanoid, Medium*

*Init +3; Atk Blunderbuss +3 ranged (15/30/45' 1d8/1d6/1d4 dmg); +2 falchion melee (1d6+2 dmg); AC 14; HD 2d10+4 (12HP); MV 30'; Act 1d20; SV Fort +2, Ref +1, Will -1; AL Law.*

Oz, short for Eozenyella /eh-ohs-en-ye-la/, is the Captain's oldest and most trusted friend. A former Warhound of the Industrial Empire who broke free of their bonds. They helped lead an uprising that toppled the Industriocracy but was then labeled a war criminal.

**Strategy:** Oz will defend the crew, and the Captain at all cost. That means doing whatever it takes to keep them safe and whole. Even, if it means stepping outside the Captain's Motto and doing a bit more killing than is absolutely necessary. A veteran of numerous skirmishes, Oz is a master tactician. Take out the most dangerous targets and work your way down that list.

### **Survis, The Surgeon**

*Strigiformine humanoid, Medium*

*Init +2; Atk Cane +0 melee (1d4); AC 11; HD 2d6 (6HP); MV 30'; Act 1d20; SV Fort +1, Ref +1, Will +3; AL Law.*

Survis is an intellectual, not a fighter, even though his people are excellent at it. But being excellent fighters also meant a dire need for skilled doctors and surgeons to undo the damage of the fighting. So, Survis took that route so he could better help his sister who became an excellent fighter. Now he searches for her as she has gone missing. He is not a fan of the Captain but follows the Motto and his personal medical code of ethics, which is somewhat self-serving at times.

**Strategy:** Actively avoids combat unless absolutely necessary. Then attacks with whatever is at hand, usually a simple ebony cane. He will rush in to administer healing to any fallen comrade with little regard for his own safety.

### **Tamra, The Striker**

*Yetine humanoid, Medium*

*Init +4; Atk Longsword +4 melee (1d8+3); Atk crossbow +2 ranged (1d6+1); Atk pistol +2 ranged (20/40/60 1d8+1); AC 15; HD 3d12+3 (20HP); MV 40'; SV Fort +3, Ref +1, Will -1; AL Chaos.*

Tamra is even larger than Vaush and their bluish skin is covered in a thick white fur like most Yetikin. Four three-inch, gnarled, horns protrude from the upper edge of Tamra's forehead and curl up and back making them even more menacing. They are a fierce fighter, and everything is seen as a competition.

**Strategy:** Hot-tempered, cold-blooded and willing to kill to better their own position. Tamra will even kill the Captain if the perfect opportunity presents itself. In battle Tamra is an unparalleled fighter with both ranged and melee weapons and will not hesitate to wade into battle and start swinging their sword tirelessly. Since everything is a competition with Tamra, they will head directly for the largest enemy, firing their ranged weapons if they are outside of melee range.

### **Krobbin, The Master Gunner**

*Raptorine humanoid, Medium*

*Init +3; Atk Pistol +3 ranged (20/40/60 1d8+2); Atk Powder Bomb +3 ranged (1d4 damage within 5', DC 13 Ref or be blinded for 1 round if hit by it); Atk Bite +1 melee (1d4+1); Atk Claw +1 melee (1d4); AC 15; HD 2d10+2 (11HP); MV 35; Act 1d20; SV Fort +1 Ref +1, Will +0; AL Neutral.*

**Strategy:** Krobbin keeps two pistols on their person at all times. They also carry small black powder bombs they use to disrupt enemies and do a little damage if they are close. Krobbin will throw a bomb or fire a pistol each round never getting within melee. However, being a Raptorine means they have a head like a dinosaur including some spiky orbital ridge and sharp teeth. A headbutt from Krobbin isn't deadly, but it will daze someone. Their bite and claws are powerful and dangerous.

#### **The Motto:**

- Smuggle, don't pirate.
- Fight when necessary, kill if absolutely necessary.
- Be straight with the crew, share equally the spoils.
- Crew may voice opinions, but the Captain's word is law on the ship.

### **Nollam, The Captain**

*Minotaur, medium*

*Init +4; Atk Pistol +3 ranged (20/40/60 1d8+2); Atk saber +3 melee (1d8+3); Atk Gore +4 melee (1d4+3); AC 14; HD 2d12+4 (14HP); MV 35; Act 1d20; SV Fort +2 Ref +1, Will +2; AL Law.*

Captain Nollam is tall, broad-shouldered, and bullheaded. Literally bullheaded as one would expect a minotaur to be, but also in terms of personality. Stubborn is not a strong enough word to describe Nollam. He fought against the Imperium Initiative and led a company of assault troops at the Calibanus Conflict. During the Sturgian Struggle, Nollam was on site as a pilot. He was the last person to put down his weapon at the Serenitian Struggle, officially ending the Imperium Initiative war in surrender, against his own desires. To this day, he is a wanted war criminal throughout the Imperium, and is seen as a hero by those who fought against them. Now, he strives without end to make a life for himself and his crew without the boot of the Imperium on their necks.

**Strategy:** Nollam does not tolerate people that he did not personally invite aboard his ship. He will fight to his last breath to protect his crew and what's his. He is stubborn and unrelenting and will not change his mind about something until actual evidence is staring him in the face, usually at the end of a weapon.



## Appendix S: The Sereneco Crew

Note: None of the places, peoples, or events in these NPC bios will be familiar to the PCs as they all exist elsewhere. Whether a far-flung region of this world or on another world entirely is unknown. At most, some of the stories may sound similar to myths or legends. Even the names of the crew would not have been learned unless through spying directly as even Vaush simply said “Quartermaster of the Sereneco” when in town buying supplies and asked for a name.

### **Vaush /vawsh/, The Quartermaster/Pilot**

*Ursine humanoid warrior, Medium*

*Init +1; Atk Saber +3 melee (1d8+3); Claw +3 melee (1d5+3); AC 12; HD 2d8+4 (10HP); MV 30'; Act 1d20; SV Fort +2, Ref +1, Will -1; AL Neutral.*

Vaush is bear folk who grew up in the high wood of Cautheron. Vaush fought in the Green Folk rebellion against the evil lord of Tuboluk and was dislodged from their home plane in the final battles. The Captain found them drifting on the Ageless Sea and took them on as crew. Turned out Vaush was a naturally gifted Aether Sailor and could sail the Aether Winds like no one the Captain had ever seen, as if the ship were a leaf on the wind.

**Strategy:** Vaush is a seasoned fighter and as such will raise the alarm to ensure the entire crew wakes to join the battle. After that Vaush will wade into the battle, first targeting the person that looks most deadly, with saber (1d20) and claw (1d16) attacks each round. A magic user of any kind will be high on the hit list, having had bad experiences with them in the past.

### **Kitlee, The Engineer**

*Grimalkine humanoid thief, Medium*

*Init +3; Atk Wrench +1 melee (1d4), Claws +1 melee (1d3), Poison Needles +3 ranged (10/20/30' (1d6 dmg), DC Fort 12 vs poison for half); AC 14; HD 2d6+2 (7HP); MV 40'; Act 1d20; SV Fort +1, Ref +3, Will +0; AL Chaos.*

The Engineer, Kitlee, hails from The Technocratic Republic of Grimalkin where the Feline Folk strive to be the most advanced society in the Seven Spheres. The strict class structure places every kitten into a classification based on intense aptitude testing. Kitlee was put into the Aether Sailing Engineering (ASE) program where she failed, miserably. She didn't fail because of an inability to do it, but because her understanding was so beyond that of the instructors that they were threatened by her and therefore contrived for her to be removed.

**Strategy:** Kitlee is not much of a physical fighter. The wrench is always with her, so she swings it as needed. She prefers to stay out of sight and attack from the shadows getting a back-stab bonus on the attack. She is fast and a fast climber (25') because of her claws. If she can get a position above the battle, she will attack with the poison needles (20) stored in a bandoleer.

### **Follier /foh-li-ay/, The Ascetic**

*Vulpine humanoid cleric, Medium*

*Init +1; Pacifist who does not participate in physical combat; AC 11; HD 2d8 (8HP); MV 35'; Act 1d20; SV Fort +0, Ref +1, Will +3; AL Law.*

Follier comes from the reclusive Sly Tribes of the Steaming Steppes where they study the silent ways of the Vulpine Collectives, each dedicated to understanding of a single aspect of the universe. Follier has scarring marks that, if one were to know of such things, denote that they were a 1st tier master of the spiritual aspect of the universe.

**Strategy:** Follier is a master of psychic combat and defense. However, they are existing in a continual state of crisis at the moment and are unable to bring themselves to attack another living creature. That is, until their life is threatened, then, as a matter of self preservation, Follier will create a mental blindspot that hides them from other living creatures. This is an innate mental ability, not magic.

### **Mental Blindspot - Roll 1d20+5**

1-10 Follier is unable to summon enough willpower to affect anything.

11-13 Follier can hide from 1 living creature they target. The target can do a Will save vs Follier's to see through the blind spot. Failure means the target is unable to mentally process the fact they are present.

14-16 Follier can hide from 1d3 living creatures they target. Targets can do a Will save to see through the blind spot.

17-19 Follier can hide 1d3 allies plus self from 1d3 living creatures they target. Targets can do a Will save vs Follier's to see through the blind spot.

20-24 Follier can hide 1d5 allies plus self from 1d4 living creatures they target. Targets can do a Will save vs Follier's to see through the blind spot.

25+ Follier can hide 1d6+2 allies plus self from 1d8 living creatures they target. Targets can do a Will save vs Follier's to see through the blind spot.

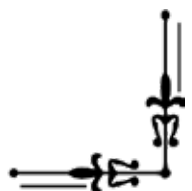

## Serranus, The Musician

Crystalline humanoid, Medium

Init +1; Atk Saber +2 melee (1d8+1); AC 11; HD 2d8+2 (9HP); MV 30'; Act 1d20; SV Fort +2, Ref +1, Will -1; AL Neutral.

While Serranus may look fragile, her crystalline form is rather sturdy. Part of a race of sentient crystals formed by residual magical energy on the Mirror Moor from the Techno-Mage Wars.

**Strategy:** Serranus is more of a diplomat than a fighter but do have a saber that they can swing fairly well. They will target the smaller, weaker looking enemies since they are not the strongest fighter themselves.

## Oz, The First Mate

Canine Humanoid. Medium

Init +3; Atk Blunderbuss +3 ranged (15/30/45' 1d8/1d6/1d4 dmg); +2 falchion melee (1d6+2 dmg); AC 14; HD 2d10+4 (12HP); MV 30'; Act 1d20; SV Fort +2, Ref +1, Will -1; AL Law.

Oz, short for Eozenyella /eh-ohs-en-ye-la/, is the Captain's oldest and most trusted friend. A former Warhound of the Industrial Empire who broke free of their bonds. They helped lead an uprising that toppled the Industriocracy but was then labeled a war criminal. Went into hiding, landing on a sand skiff collecting iron gems in the Driftless Desert where they met the Captain, saved enough to start their own skiff and worked up from there. Strictly follows the Captain's Motto (see below)

**Strategy:** Oz will defend the crew, and the Captain at all cost. That means doing whatever it takes to keep them safe and whole. Even, if it means stepping outside the Captain's Motto and doing a bit more killing than is absolutely necessary. A veteran of numerous skirmishes, Oz is a master tactician. Take out the most dangerous targets and work your way down that list.

## Survis, The Surgeon

Strigiformine humanoid, Medium

Init +2; Atk Cane +0 melee (1d4); AC 11; HD 2d6 (6HP); MV 30'; Act 1d20; SV Fort +1, Ref +1, Will +3; AL Law.

Survis is an intellectual, not a fighter, even though his people are excellent at it. But being excellent fighters also meant a dire need for skilled doctors and surgeons to undo the damage of the fighting. So, Survis took that route so he could better help his sister who became an excellent fighter. Now he searches for her as she has gone missing. He is not a fan of the Captain but follows the Motto and his personal medical code of ethics, which is somewhat self-serving at times.

**Strategy:** Actively avoids combat unless absolutely necessary. Then attacks with whatever is at hand, usually a simple ebony cane. He will rush in to administer healing to any fallen comrade with little regard for his own safety.

## Tamra, The Striker

Yetine humanoid, Medium

Init +4; Atk Longsword +4 melee (1d8+3); Atk crossbow +2 ranged (1d6+1); Atk pistol +2 ranged (20/40/60 1d8+1); AC 15; HD 3d12+3 (20HP); MV 40'; SV Fort +3, Ref +1, Will -1; AL Chaos.

Tamra is even larger than Vaush and their bluish skin is covered in a thick white fur like most Yetikin. Four three-inch, gnarled, horns protrude from the upper edge of Tamra's forehead and curl up and back making them even more menacing. They are a fierce fighter, and everything is seen as a competition. That makes them ambitious and often Tamra will try to usurp power from the Captain, rarely with any support from the rest of the crew.

**Strategy:** Hot-tempered, cold-blooded and willing to kill to better their own position. Tamra will even kill the Captain if the perfect opportunity presents itself. In battle Tamra is an unparalleled fighter with both ranged and melee weapons and will not hesitate to wade into battle and start swinging their sword tirelessly. Since everything is a competition with Tamra, they will head directly for the largest enemy, firing their ranged weapons if they are outside of melee range.

## Krobbin, The Master Gunner

Raptorine humanoid, Medium

Init +3; Atk Pistol +3 ranged (20/40/60 1d8+2); Atk Powder Bomb +3 ranged (1d4 damage within 5', DC 13 Ref or be blinded for 1 round if hit by it); Atk Bite +1 melee (1d4+1); Atk Claw +1 melee (1d4); AC 15; HD 2d10+2 (11HP); MV 35'; Act 1d20; SV Fort +1 Ref +1, Will +0; AL Neutral.

**Strategy:** Krobbin keeps two pistols on their person at all times. They also carry small black powder bombs they use to disrupt enemies and do a little damage if they are close. Krobbin will throw a bomb or fire a pistol each round never getting within melee. However, being a Raptorine means they have a head like a dinosaur including some spiky orbital ridge and sharp teeth. A headbutt from Krobbin isn't deadly, but it will daze someone. Their bite and claws are powerful and dangerous.

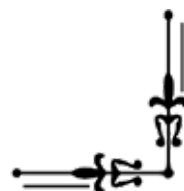

## **Nollam, The Captain**

*Minotaur, medium*

*Init +4; Atk Pistol +3 ranged (20/40/60 1d8+2); Atk saber +3 melee (1d8+3); Atk Gore +4 melee (1d4+3); AC 14; HD 2d12+4 (14HP); MV 35'; Act 1d20; SV Fort +2 Ref +1, Will +2; AL Law.*

Captain Nollam is tall, broad-shouldered, and bullheaded. Literally bullheaded as one would expect a minotaur to be, but also in terms of personality. Stubborn is not a strong enough word to describe Nollam. He fought against the Imperium Initiative and led a company of assault troops at the Calibanus Conflict. During the Sturgian Struggle, Nollam was on site as a pilot. He was the last person to put down his weapon at the Serenitian Struggle, officially ending the Imperium Initiative war in surrender, against his own desires. To this day, he is a wanted war criminal throughout the Imperium, and is seen as a hero by those who fought against them. Now, he strives without end to make a life for himself and his crew without the boot of the Imperium on their necks.

**Strategy:** Nollam does not tolerate people that he did not personally invite aboard his ship. He will fight to his last breath to protect his crew and what's his. He is stubborn and unrelenting and will not change his mind about something until actual evidence is staring him in the face, usually at the end of a weapon.

**The Motto:** Smuggle, don't pirate. Fight when necessary, kill if absolutely necessary. Be straight with the crew, share equally the spoils. Crew may voice opinions, but the Captain's word is law on the ship.

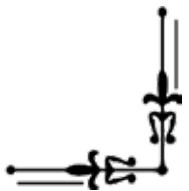



# Appendix D - DTC Tokens & Maps

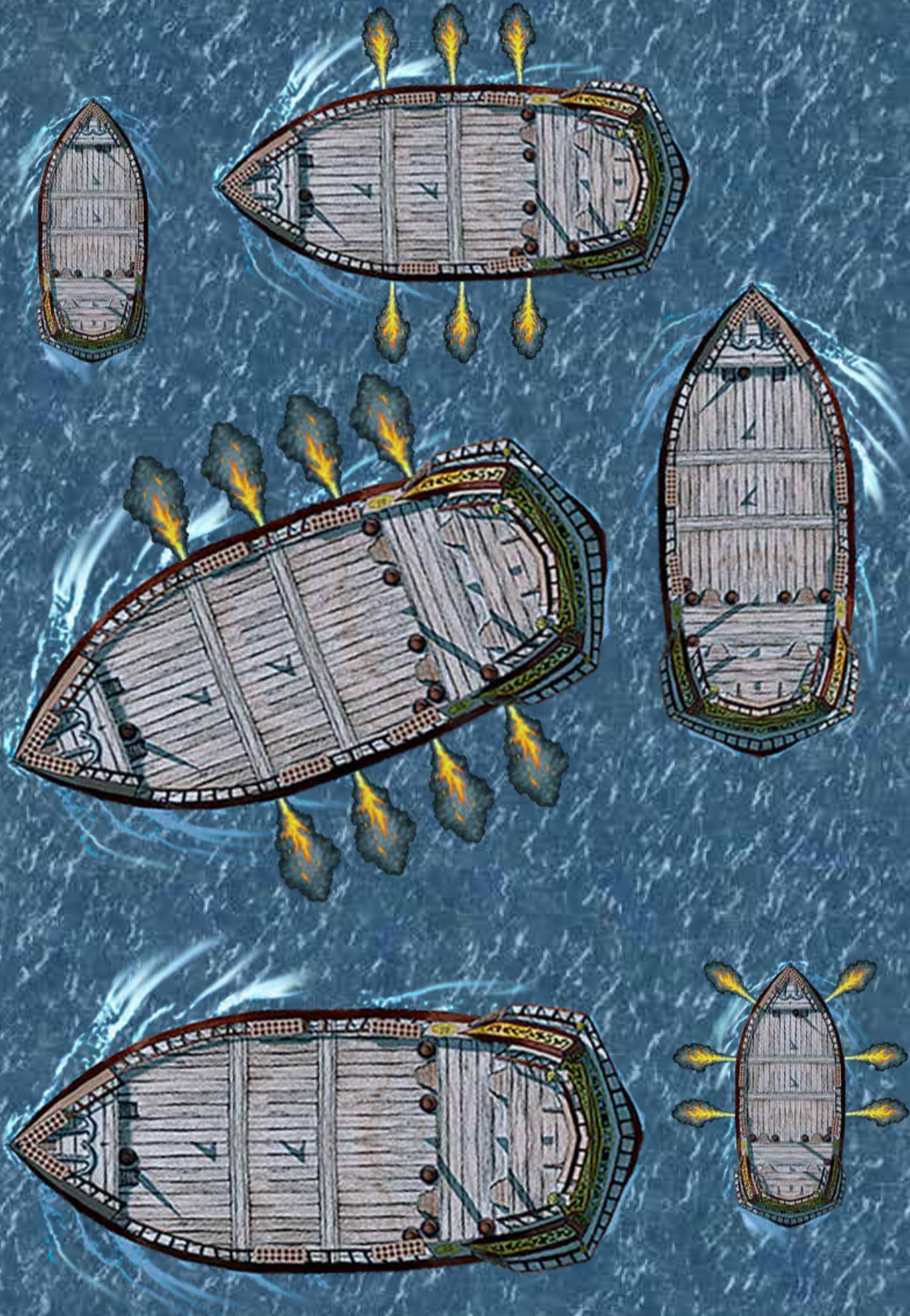



# THE SERPECO







LOSTPORT  
HALL

Niska's

HOBAN'S  
HAVEN

CRUSTY  
RANGOLIN

THE  
SERENECO

LOSTPORT







This printing of *Let's Be Bad Guys: Pirates* is done under version 1.0 of the Open Gaming License, and the System Reference Document by permission from Wizards of the Coast, Inc.

#### Designation of Product Identity

All illustrations, art, place names, character names, names of organizations and similar proper nouns introduced in this publication are product identity, including but not limited to *Two-Hour Tales*, and *Quick Crawls*. All text that does not describe a discrete game element is product identity. All content that is product identity for DCC remains product identity for DCC.

#### Designation of Open Game Content

All game statistics, and stat blocks, for any game elements included in this publication are designated open game content.

#### OPEN GAME LICENSE Version 1.0a

The following text is the property of Wizards of the Coast, Inc. and is Copyright 2000 Wizards of the Coast, Inc ("Wizards"). All Rights Reserved.

**1 Definitions:** (a) "Contributors" means the copyright and/or trademark owners who have contributed Open Game Content;

(b) "Derivative Material" means copyrighted material including derivative works and translations (including into other computer languages), potation, modification, correction, addition, extension, upgrade, improvement, compilation, abridgment or other form in which an existing work may be recast, transformed or adapted;

(c) "Distribute" means to reproduce, license, rent, lease, sell, broadcast, publicly display, transmit or otherwise distribute;

(d) "Open Game Content" means the game mechanic and includes the methods, procedures, processes and routines to the extent such content does not embody the Product Identity and is an enhancement over the prior art and any additional content clearly identified as Open Game Content by the Contributor, and means any work covered by this License, including translations and derivative works under copyright law, but specifically excludes Product Identity.

(e) "Product Identity" means product and product line names, logos and identifying marks including trade dress; artifacts; creatures characters; stories, storylines, plots, thematic elements, dialogue, incidents, language artwork, symbols, designs, depictions, likenesses, formats, poses, concepts, themes and graphic, photographic and other visual or audio representations; names and descriptions of characters, spells, enchantments, personalities, teams, personas, likenesses and

special abilities; places, locations, environments, creatures, equipment, magical or supernatural abilities or effects, logos, symbols, or graphic designs; and any other trademark or registered trademark clearly identified as Product identity by the owner of the Product Identity, and which specifically excludes the Open Game Content;

(f) "Trademark" means the logos, names, mark, sign, motto, designs that are used by a Contributor to identify itself or its products or the associated products contributed to the Open Game License by the Contributor

(g) "Use", "Used" or "Using" means to use, Distribute, copy, edit, format, modify, translate and otherwise create Derivative Material of Open Game Content.

(h) "You" or "Your" means the licensee in terms of this agreement.

**2 The License:** This License applies to any Open Game Content that contains a notice indicating that the Open Game Content may only be Used under and in terms of this License. You must affix such a notice to any Open Game Content that you Use. No terms may be added to or subtracted from this License except as described by the License itself. No other terms or conditions may be applied to any Open Game Content distributed using this License.

**3 Offer and Acceptance:** By Using the Open Game Content You indicate Your acceptance of the terms of this License.

**4 Grant and Consideration:** In consideration for agreeing to use this License, the Contributors grant You a perpetual, worldwide, royalty free, non-exclusive license with the exact terms of this License to Use, the Open Game Content.

**5 Representation of Authority to Contribute:** If You are contributing original material as Open Game Content, You represent that Your Contributions are Your original creation and/or You have sufficient rights to grant the rights conveyed by this License.

**6 Notice of License Copyright:** You must update the COPYRIGHT NOTICE portion of this License to include the exact text of the COPYRIGHT NOTICE of any Open Game Content You are copying, modifying or distributing, and You must add the title, the copyright date, and the copyright holder's name to the COPYRIGHT NOTICE of any original Open Game Content you Distribute.

**7 Use of Product Identity:** You agree not to Use any Product Identity, including as an indication as to compatibility, except as expressly licensed in another, independent Agreement with the owner of each element of that Product Identity. You agree not to indicate compatibility or co-adapt-

ability with any Trademark or Registered Trademark in conjunction with a work containing Open Game Content except as expressly licensed in another, independent Agreement with the owner of such Trademark or Registered Trademark. The use of any Product Identity in Open Game Content does not constitute a challenge to the ownership of that Product Identity. The owner of any Product Identity used in Open Game Content shall retain all rights, title and interest in and to that Product Identity.

**8 Identification:** If you distribute Open Game Content You must clearly indicate which portions of the work that you are distributing are Open Game Content.

**9 Updating the License:** Wizards or its designated Agents may publish updated versions of this License. You may use any authorized version of this License to copy, modify and distribute any Open Game Content originally distributed under any version of this License.

**10 Copy of this License:** You MUST include a copy of this License with every copy of the Open Game Content You Distribute.

**11 Use of Contributor Credits:** You may not market or advertise the Open Game Content using the name of any Contributor unless You have written permission from the Contributor to do so.

**12 Inability to Comply:** If it is impossible for You to comply with any of the terms of this License with respect to some or all of the Open Game Content due to statute, judicial order, or governmental regulation then You may not Use any Open Game Material so affected.

**13 Termination:** This License will terminate automatically if You fail to comply with all terms herein and fail to cure such breach within 30 days of becoming aware of the breach.

All sub-licenses shall survive the termination of this License.

**14 Reformation:** If any provision of this License is held to be unenforceable, such provision shall be reformed only to the extent necessary to make it enforceable.

#### 15 COPYRIGHT NOTICE

Open Game License v 1.0 Copyright 2000, Wizards of the Coast, Inc. System Reference Document. Copyright 2000, Wizards of the Coast, Inc.; Authors Jonathan Tweet, Monte Cook, Skip Williams, based on material by E. Gary Gygax and Dave Arneson.

DCC RPG, copyright © 2012 Goodman Games, all rights reserved, visit [www.goodmangames.com](http://www.goodmangames.com) or contact [info@goodman-games.com](mailto:info@goodman-games.com) FOURTH PRINTING

*Let's Be Bad Guys: Pirates*, © 2020 2 Old Guys Games, LLC; Authors: Christopher Rick & Michael Spredemann

End of license.

