

CINEMATIC FLEET COMBAT SYSTEM

LIGHTNING STRIKE

SECOND EDITION

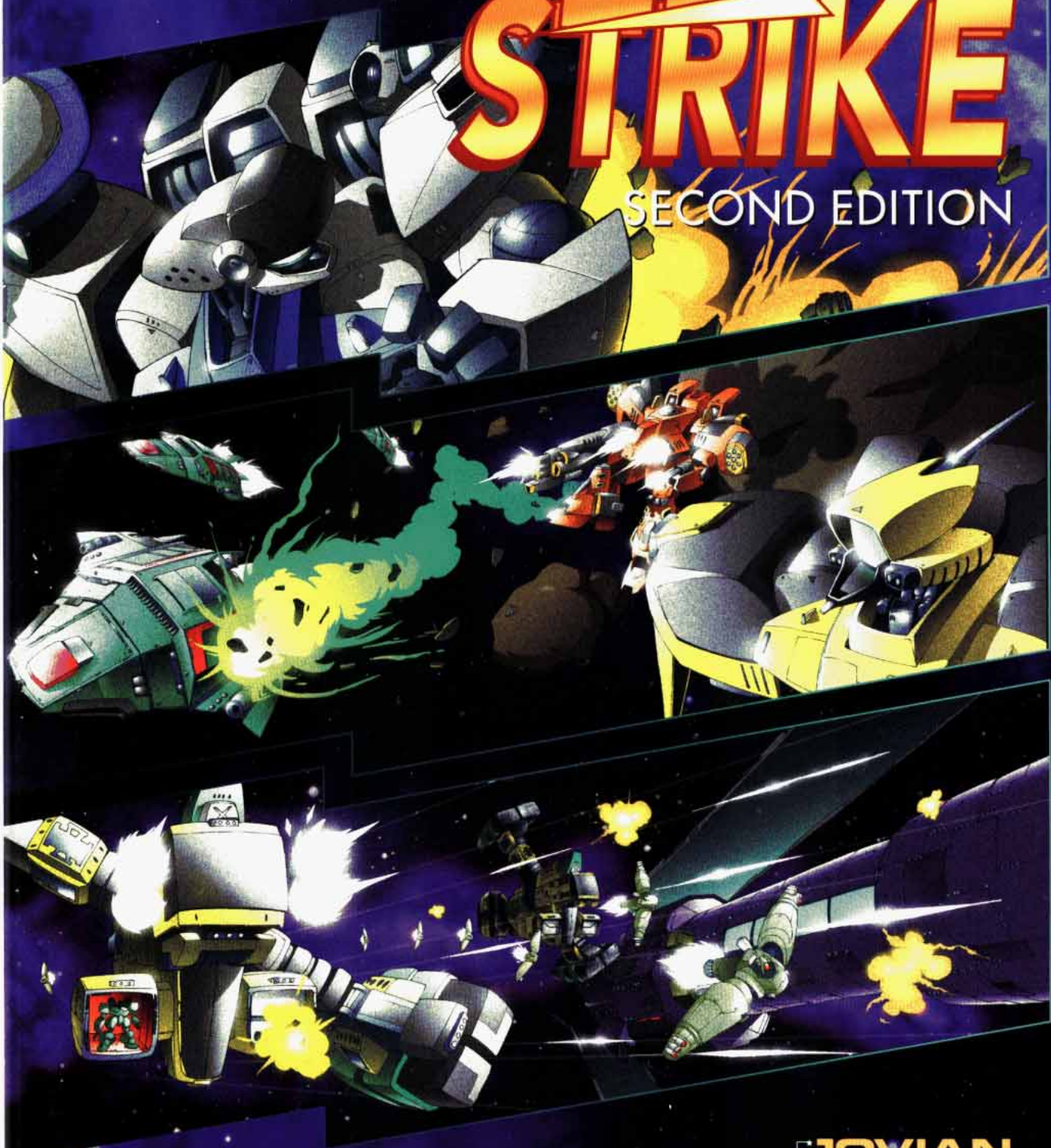

JOVIAN
CHRONICLES
FROM DREAM POD 9



★ JOVIAN ● CHRONICLES



The strike carrier thundered ahead, its massive hull gleaming in the light of the distant Sun. Its companions were spread out in a loose attack formation, ready to cut a swath through CEGA's massed fleet.

"Launch flash! Missile launch confirmed. We're getting a fix on the launcher - "

"Captain, I'm reading several bogeys twenty clicks off our port bow", said the tactical officer. "Not fighters... Velocity's wrong. Wait." The crewman punched a few controls and pointed at his screen. "Confirmed — Wyvern-class exo-armors on standard inbound attack vector."

"Damn! Scramble the pilots. I want them out there now!"

The ship was rocked by a large explosion as one of the exos opened fire with its massive arm-mounted gun. The attacker was blown in half as it turned to fire a second volley, its powerplant exploding in a blinding flash of light. A Stormrider exo-armor flashed a victory sign to the relieved bridge crew before heading off to hunt down the rest of the attackers.

Lightning Strike is a game of tactical fleet combat set in the universe of the Jovian Chronicles. Players take the part of ship commanders in the conflict, viewing the battle from above and giving orders to the participating units. This book includes basic rules and game stats allowing players to take the side of the Jovian Confederation, the Central Earth Government and Administration (CEGA) or the Cooperative Venusian Naval Administration (CVNA).

- Quick Start basic rules to start playing immediately;
- Full rules for fielding exo-armors, fighters, exo-suits and warships;
- Advanced rules for aces, boarding actions and electronic warfare;
- Basic scenarios and extensive campaign rules;
- Game statistics for the major Jovian, CEGA and Venusian combat spacecraft;
 - A full-color game counter sheet.

DP9 - 322



www.dp9.com

ISBN: 1-896776-82-5



9 781896 776828

A few six-sided dice, miniatures, pen and paper are required to play the game.

PRINTED IN CANADA

JOVIAN
CHRONICLES

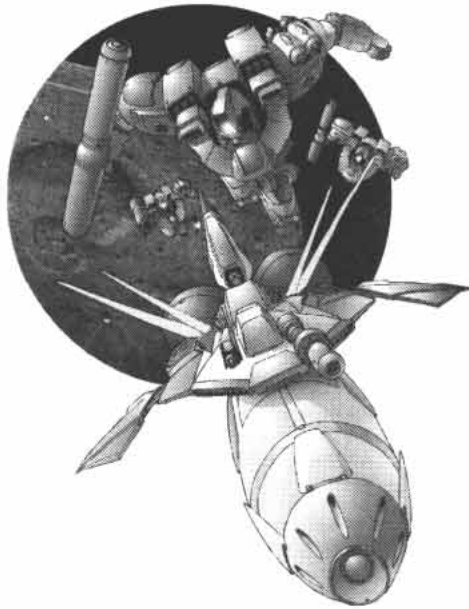



► DREAM POD 9

▼ WRITING

Wunji Lau Writer/System Design
 Christian Schaller Editor
 Marc A. Vezina Senior Editor/
 Developer
 Hilary Doda Copy Editor

▼ PRODUCTION

Pierre Ouellette Art Direction/
 Designer
 Jean-Francois Fortier Layout Artist
 Ghislain Barbe Illustrator/Colorist
 John Wu Illustrator/Colorist
 Marc Ouellette Computer
 Illustrator/Colorist
 Alain Gadbois Miniatures and
 Scenery Modeler/Photograph
 Marcel Bastien Miniatures and
 Scenery Modeler
 Dimitri Kalivatis Miniatures and
 Scenery Modeler

▼ ADMINISTRATION

Robert Dubois Administration

▼ SUBCOLUME

Gene Macell System Designer
 Stephane J. Matis System
 Designer
 Wunji Lau Lightning Strike Rules
 Designer
 Marc A. Vezina System Developer

▼ SPECIAL THANKS

Chris Schaller, Frank Foulis,
 Robert Mitchell, Robert Glass,
 Robert Beck, Alison Crawford,
 Doug Jessee, Patrick Paulsen,
 Ken Winland, Dave Graham,
 Patrick Bohner, Albert Nakano
 and the entire Jovian Chronicles
 mailing list all playtested and
 gave some much-needed advice,
 information, and browbeating.

This game is dedicated to Wendy
 Lau; if it ain't broke, it doesn't
 have enough features yet.

CHAPTER 1: INTRODUCTION

Intro Fiction	4-5
1.1 Introduction	6
1.1.1 What's Different?	6
1.2 Book Content	7
Basic Rules	7
Intermediate Rules	7
Advanced Rules	7
Scenarios and Campaigns	7
Hardware	7
Vehicles and Spacecraft	7
1.3 What You Need to Play	8
Miniatures	8
Ruler	8
Dice	8
Playing Field	8
Counters	8
Binders and Markers	9
1.3.1 Standard Unit Datacard	10
1.3.2 Spaceship Datacard	11
1.4 Core Game Concepts	12
1.4.1 Scale	12
1.4.2 Unit Types	12
Exo-Armor	12
Fighter	12
Exo-Suit	12
Spaceship	12
1.4.3 Variable Unit Characteristics	13
Group	13
Skill Level	13
Skill Bonus	13
1.4.4 Dice and Dice Rolling	13
Dice	13
Threshold	13
Chapter 2: Basic Rules	14
2.1 Turn Sequence	14
2.1.1 Initial Set-up	14
2.1.2 The Game Turn	14
Initiative Phase	14
First Ship Phase	14
Main Phase	15
Second Ship Phase	16
End Phase	16
Ending the Game	16
2.2 Movement	17
2.2.1 Exo-Armors	17
2.2.2 Exo-Suits	18
2.2.3 Fighters	18
2.2.4 Spaceships	19
2.2.5 Moving Off the Board	19
2.3 Actions	20
2.3.1 Ship Actions	20
Damage Control	20
Fire Weapons	20
Ping	20
Spoof	20
Thrust	20
2.4 Combat	21
2.4.1 Line of Sight	21
2.4.2 Range	22
2.4.3 Avoidance	22
2.4.4 Fire Arcs	23
2.4.5 Attacking	24
Attacking with Ships	24
Attacks against Ships	24
Close Combat	25
The Attack Roll	25
Combining Attacks	26
2.5 Damage	28
2.5.1 Damage Types and Special Defenses	28
2.5.2 Damage to Standard Units	29
2.5.3 Damage to Spaceships	29
Hit Locations	30
Catastrophic Damage and Explosions ...	31

CHAPTER 3: INTERMEDIATE RULES

3.1 Expanded Activation Options	34
3.1.1 Evading	34
3.1.2 Aiming	34
3.1.3 Reaction Attacks	34
3.2 Ship Vector Movement	35
3.3 Expanded Close Combat Option	36
3.3.1 Grappling	37
Grappling Procedures	37
Winning the Grapple	38
3.4 Command Points	39
3.4.1 Command Point Uses	39

CHAPTER 4: ADVANCED RULES

4.1 Aces	40
Skill Level and Bonus	40
4.1.1 Ace Perks	40
Parting Shot	40
Command Points	40
Aura of Command	40
Blind Luck	40
Charmed Life	40
Inspirational	40
Lightning Reflexes	40
Melee Master	40
Nerves of Steel	40
Quick and Wily	40
Sixth Sense	40
4.1.2 Ace Cost	41
Ace Basic Cost Table	41
4.2 Electronic Warfare	41
4.3 Infantry	42
4.4 Boarding Actions	42
4.5 Obstacles	43
Asteroids	43
Debris Fields	43
Dust Clouds	43
Factory Complexes	43
Rock Fields	43
4.5.1 Installations	43
Cargo Barges	43
Skyhooks	43
Space Stations	43
4.5.2 Low Orbit	44
4.5.3 Minefields	44
4.5.4 Noisemaker Shrouds	45
4.6 Ramming	45
4.7 Lightning Strikes	46
4.7.1 During the Game	46
4.7.2 After the Game	46
Intermission Fiction	47

CHAPTER 5: CAMPAIGNS

5.2 Single Games	48
Basic Scenario 1: The McGuffin Scenario	48
Basic Scenario 2: The Hot Flash Situation	49
Basic Scenario 3: The St. Bernard Exercise	49
Basic Scenario 4: The Alamo Eventuality	49
5.3 The Campaign	50
5.3.1 Campaign Stats	50
Repair Value	50
Fleet Maneuver	50
5.3.2 Assembling the Fleet	50
Support Ships	51
Cargo Points	51
Stealing Cargo	51
Special Rule for Venusian CVNA Fleets	51
Leadership	51
Optional Rules	51
5.3.3 Playing the Campaign	52
The Strategy Phase	52
Fleet Maneuver	52
Selecting a Scenario	52
The Strategy Roll	52
The Battle	52
Obstacle Table	52

Special Rules for Venusian CVNA Fleets 52
 The Repair Phase 53
 Salvage 53
 Regrouping 54
 Survival 54
 Ship Repair 54
 Standard Unit Repair 54
 Experience 55
 Campaign Points 55
 Reinforcements 55
 Ending a Campaign 55
 5.3.4 The Campaign Scenarios 56
 Knock, Knock 56
 Vamp 56
 Vandalism 56
 Face of the Enemy 57
 Nobody Home 57
 Headhunter 57
 Scenario: Outnumbered 58
 Back Shot 58
 Full Contact 58
 Campaign Fleet Roster 59

CHAPTER 6: HARDWARE

6.1 Perks and Flaws 60
 6.1.1 Basic Perks and Flaws 60
 Concealed Sections 60
 Energy/Projectile Protection (#/#/#) 60
 Exposed Fire Control 60
 Missile Defense (#) 60
 Multiple Redundancy 60
 Reinforced Systems (#) 60
 Target Designator (#) 60
 Venusian 60
 6.1.2 Cargo 60
 Internal Cargo 60
 External Cargo 60
 6.1.3 Cloak 61
 Deep Cloak 61
 6.1.4 Close Combat Optimized (#) 62
 Clamping 62
 6.1.5 Electronic Warfare (#) 62
 Electronic Counter Measures (ECM) 62
 Targeted ECM 62
 Electronic Counter Counter Measures (ECCM) 63
 6.1.6 Stealth 63
 6.2 Weapons and Weapon Characteristics ... 64
 6.2.1 Basic Weapon Characteristics 64
 Anti-Infantry (AI#) 64
 Anti-Ship (AS#) 64
 Armor-Destroying (AD) 64
 Armor Piercing (AP) 64
 Energy-Homing (EH) 64
 Flak (FI) 64
 Haywire (H) 64
 Missile (Mis) 64
 Power-Hungry (PH#) 64
 Rapid Fire (R#) 64
 Ship Missiles (S-Mis) 64
 Slow (Slw#) 64
 Seek (Sk#) 64
 Self-destruction (SD) 64
 Stealthy (St) 64
 Sweeping (Swp#) 64
 Target Designator (TD) 64
 6.2.2 Ship Missile Bays 65
 Lock-on Rolls 65
 6.2.3 Point Defense Systems (PDS) 65
 Standard Mode, Offense 66
 Standard Mode, Defense 66
 Shield Mode, Offense 66
 Shield Mode, Defense 66
 6.3 Drones 67
 Class I Drones 67
 Class II Drones 67
 Class III Drones 67

6.3.1 Drone Carriers 67
 Drone Class or Type 67
 Rate, Launch 67
 Reload Threshold 67
 6.3.2 Launching Drones 68
 6.3.3 Drone Data Cards 68
 Threat Value 68
 Skill Threshold 68
 Protection 68
 6.3.4 Drone Movement and Actions 69
 6.5 Options and Add-ons 70
 6.5.1 Exo-Armor and Fighter Weapons ... 70
 Swarms 70
 Light Missiles 70
 Medium Missiles 70
 Heavy Missiles 70
 HARM Missiles 70
 Assault Railgun 70
 Drone Rack 70
 Beam Cannon 70
 Sentry Pod 70
 Melee Weapons 70
 6.5.2 Exo-Armor and Fighter Equipment . 71
 Anti-Missile System 71
 EW Pod 71
 Target Designator 71
 Executor Copilot 71
 Advanced Fire Control 71
 Snoopy Pod 71
 Ablative Armor 71
 Battle Arms 71
 Shield 71
 Booster Pack 71
 Vernier Module 71
 Chameleon Refit 71
 6.5.3 Exo-Suit Equipment 71
 Claymores 71
 Toolkits 71
 Booster Pack 71
 Shields 71
 Target Designator 71
 6.5.4 Ship Equipment 71
 Proximity Mines 71
 HEAT-Resistant Armor 71
 Decoy Pod 71
 Diogenes System 71
 Repair Bots 71
 EW Rig 71
 6.6 Ship Ability: Launch and Recovery 72
 Launch 72
 Recovery 72
 Vehicle Bays 72
 6.7 Standard Unit Ability: Tagging 72
 Tagging Range 72
 Tagging Rolls 72
 Hardware Reference Table 73

CHAPTER 7: VEHI. AND SPACECRAFT

7.1 Fleet Lists 74
 7.1 The Solar System in 2214 74
 7.2 The Jovian Confederation 75
 7.2.1 Jovian Armed Forces 75
 7.2.2 JAF Fleet List 80
 7.3 The Central Earth Government and Admin. 81
 7.3.1 The CEGA Navy 81
 7.3.2 CEGA Navy Fleet List 86
 7.4 Venus 87
 7.4.1 Cooperative Venusian Naval Admin. ... 87
 7.4.2 CVNA Fleet List 91
 7.5 Neutral and International Units 92
 7.5.1 Common Ships 92
 Intermision Fiction 93
 Appendixes
 Datacards 94-110
 Reference Sheets 111-112

PRODUCED AND PUBLISHED BY:



Dream Pod 9
 5000 Iberville # 332
 Montreal, QC
 Canada
 H2H 2S6

All art, characters and designs
 ©1992, 1994, 1997, 1998, 1999
 2000 Dream Pod 9, Inc.

The Dream Pod 9 logo, Jovian
 Chronicles, Silhouette, Exo-Armor,
 Exo-Suit, Exo-Fighter, Jovian
 Confederation, Central Earth
 Government & Administration and all
 distinctive logos and terms are
 trademarks of Dream Pod 9, Inc.
 Copyright © 1992, 1994, 1997, 1998,
 1999, 2000 Dream Pod 9, Inc. All
 Rights Reserved.

No part of this book can be
 reproduced without written
 permission from the publisher,
 except for short excerpts for review
 purposes. Any similarities to
 characters, situations, institutions,
 corporations, etc. without all these
 intent, are strictly coincidental.

The use of the male gender
 throughout this manual should not
 imply exclusion of the female
 gender. It is meant only in order to
 avoid pronouns like "him/her/it",
 making the text lighter and easier to
 read.

Dream Pod 9 can be reached
 through the Internet. Look for our
 page on the World Wide Web at
<http://www.dp9.com>.

Also, check out the all-games.dp9
 rec.games.mech and
 rec.games.fpp.mil newsgroups for
 support and information about the
 Jovian Chronicles.

Stock # DP9-327

Legal Deposit: November 2000

Bibliothèque Nationale du Québec

National Library of Canada

ISBN 1-896776-82-5

Printed in Canada

▶ VALUE JUDGMENTS

Helena Juno wrenched her control sticks to the left, firing thrusters that sent the Lancer into a hard sideslip. A stream of tracers drew a line through the space her fighter had just occupied.

"Who is this guy?" she muttered. Behind her, dwarfing her slim fighter, the dirty-green Dragonstriker surged forward on full burn, as if attached to her rear end by a rubber band.

"Who cares?" came Wang Ling's bored voice over the comm. "He sure doesn't know how to treat a lady. Although, I suppose I can't be sure about that, since I don't see any around at the moment."

Helena sighed, dipping her fighter's nose to dodge an azure particle bolt. Ling was a lot of fun to have around on boring search-and-recover ops, but when things got hairy, she found him impossible to put up with. The rest of the squadron loved him, though, so he'd gotten to come along with Helena, right into a CEGA ambush. Things had been going well, and then the maniac in the giant green exo-armor had shown up and taken a liking to Helena's tailfin.

"I'll kick your ass later for that. For now, can you just get this nut off my tail?" Helena looked around, but saw no sign of Ling. Ling's response, however, was as lackadaisical as always.

"As usual, I'm way ahead of you." Like an Olympian thunderbolt, Ling's Pathfinder streaked down from above, cutting neatly between Helena and her pursuer. The battered Dragonstriker broke hard to avoid Ling's first shot, leaving Helena some breathing room. Gee-forces pushed her deep into her seat as she threw the Lancer onto another evasive vector. Despite its own elusive acrobatics, the Dragonstriker continued to shoot at Helena, lighting the dark void with blinding blue bolts of fire.

Halfway through her spin, Helena's comm chirped with a message from one of the other exos in her squadron.

"Colonel," came the concerned male voice, "there's a group of light warships closing at relative cruise delta-vee. Looks like two Bricks and one Hachi."

Before she could reply, a scrambled burst communication from the fleet appeared in glowing text on her helmet faceplate. *Main fleet under attack, it read. Return to Home One ASAP.*

"Nothing is ever easy in this job," Helena grouched through clenched teeth. Glancing over her shoulder, she saw the green exo-armor, still hounding her.

Ling spun around and fired again, this time connecting with the Dragonstriker's back. As sheets of electrical discharge played over the Dragonstriker's skin, the massive exo cut thrust and slowly turned around to face Ling at a range of only a few hundred meters. One clawed hand, large enough to engulf a Pathfinder's head, pointed a judging finger at Ling, and casually blew apart the Pathfinder's particle cannon with a burst of cannon fire.

"Well, I was wondering when I'd get your attention." Helena didn't miss the quaver in Ling's normally cheerful voice.

"Ling!" she shouted, kicking her thrusters to maximum and drawing an attack vector to the Dragonstriker. Five seconds to range, she thought, watching her targeting reticule. It seemed to crawl across the viewscreen with an exaggerated slowness, as if to mock her efforts, but it was closing in on its quarry.

The Dragonstriker seemed to stare at Ling's Pathfinder, as if taking the smaller machine's measure. Ling raised his exo's fists in a futile gesture of defiance. Three seconds. I'm not going to make it, Helena realized. She fired off a cluster of missiles at extreme range, hoping to distract the huge war machine, but the missiles didn't even get a firm lock before the Dragonstriker blew them to bits.

For a moment, nothing happened. The Dragonstriker floated in space, silent and unmoving. Then, with an almost contemptuous glance over its shoulder at Helena, the green exo-armor suddenly lit its thrusters at full burn, rocketing away from the bewildered Jovians. Cutting in her retros, Helena slowed to a relative halt next to Ling, letting the enemy leave the field unmolested.

"Great," muttered Ling. "I'm not good enough to kill. I'm insulted. That guy is definitely off my Inception Day gift list."

"Ling, you're not good enough for me to kill," Helena snipped. "But thanks for the help anyway."

Ling's exo turned to the left. Following its gaze, Helena saw about a dozen points of light growing closer, moving in tight formation. Took them long enough, she thought.

"My po-po always told me to respect the elderly," said Ling, before switching to the squadron-wide channel to address his incoming compatriots. "And thank you, everyone, by the way, for your timely assistance."

"Sorry we're late," came the apologetic reply. "We cleared out most of the other CEGA units, but then the rest just suddenly retreated." The Jovian exo-armors and fighters folded into neat formation around Ling and Helena.

"Yeah, seems to be a lot of that going around," Helena said. "Okay, let's deal with the situation at hand. Groups Gabriel and Chatterbox, secure this area and search for the objective. If those ships get too close, take 'em out, but if the exos come back for a rematch, run for it — it's not worth the risk."

A chorus of affirmative responses inundated Helena's headset. To her left, four Lancers and an equal number of broad-shouldered Vindicators peeled off and flowered out into a scattered formation.

"Ling," she continued, "gather your group. We need to get back to the fleet. If Admiral Lin's attacking, then Jay's going to need all the help he can get."

Ling sighed.

"With our luck, we'll end up engaging her personally. I knew I should have taken ballet like mom wanted me to. Instead, I get to be target practice for Gawain the Green Nut."

With that, he turned his exo's back to the oncoming CEGA corvettes and lit his burners.

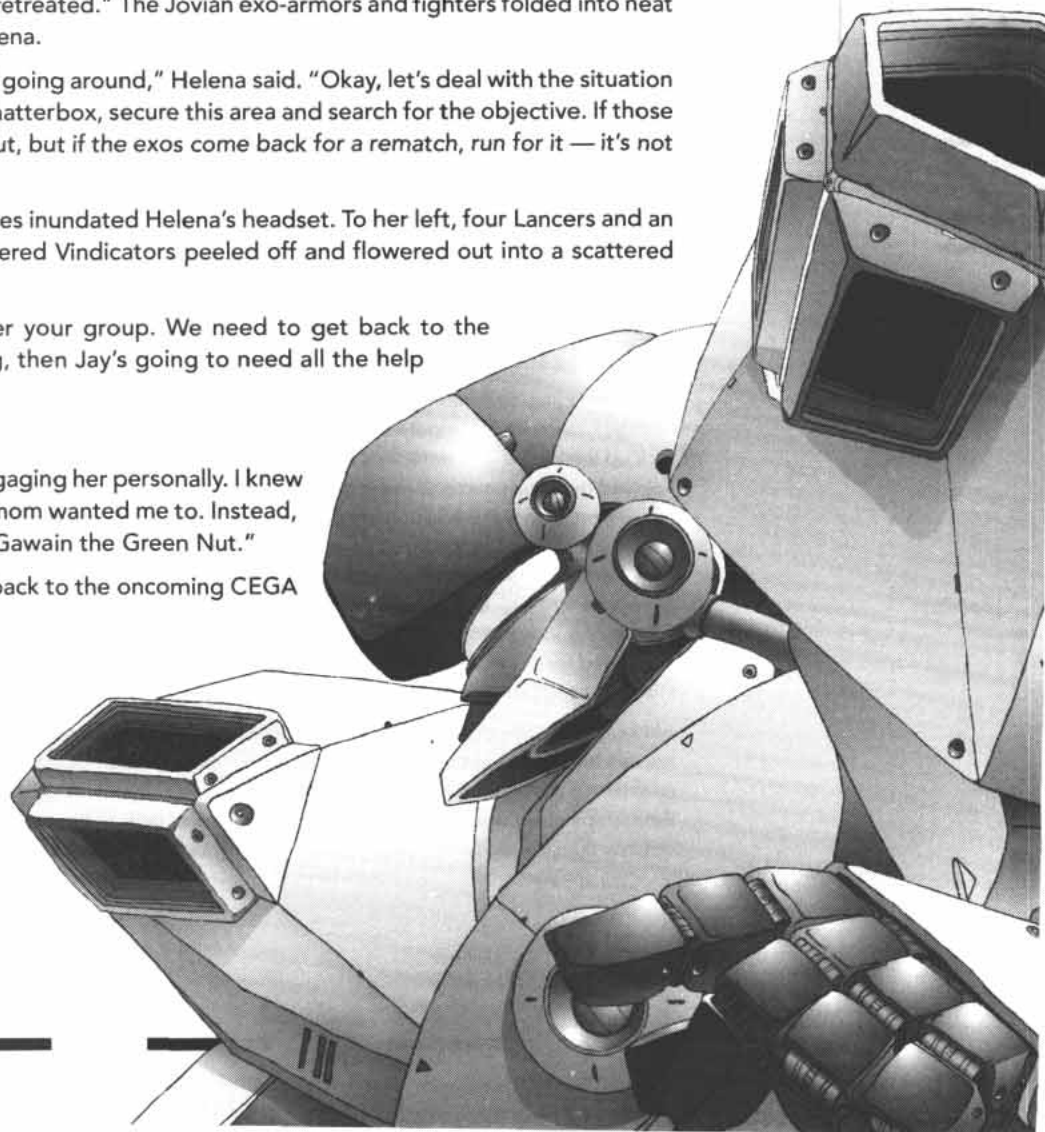

▶ INTRODUCTION

From the ashes of the Fall, humanity rose, phoenix-like, soaring outward into the Solar System. Over the course of a century, they built new homes, new nations and new societies. When, at long last, contact between the worlds resumed, all of humanity rejoiced at the dawn of a new age of peace and unity. Two decades later, though, mistrust, greed and old hatreds slowly chip away at the new brotherhood of humanity, bringing the Solar System ever closer to the chaos of war. The year is 2214. Humans have conquered space. Now it is time to conquer each other.

Jovian Chronicles: Lightning Strike is a tabletop miniatures wargame that allows players to control fleets of massive warships and squadrons of nimble exo-armors and fighters in battle for control of the Solar System. Set in the politically-charged universe of the Jovian Chronicles, the **Lightning Strike** rules themselves are also readily adaptable to virtually any space-combat setting. This 2nd-edition rulebook combines the rules from the three previously released books into a single volume, and makes some corrections and additions to the original books. Future **Lightning Strike** releases will cover orbital assaults and ground combat on the various worlds, moons and planetoids of the Solar System.

Three major military forces currently spar with each other in the Solar System. The Jovians, powerful and idealistic, have built a vast nation of spaceborne colonies in the orbit of Jupiter. Having lived in space for more than a century, they are masters of space combat. Their avowed goal of saving the inner Solar System from the tyranny of Earth and Venus stems both from the nobility of the Jovian people as well as the greed and arrogance of their leadership.

Directly opposite the Jovians on the battlefield is the Central Earth Government and Administration, inheritors of the battered home planet of humanity. Stubborn, imperialistic and xenophobic, the Earthers seek to establish dominion over the other planets, which they perceive as rogue colonies. Not only will doing so reestablish Earth as the dominant power in the Solar System, but it will enable CEGA to turn its resources inward to feed its people and rebuild Earth's shattered biosphere.

The Venusians are a wild card in Solar System politics. Wealthy, urbane and ambitious without limit, their small but effective military is a cause for concern for both the Jovians and CEGA, as are their ambiguous goals. The corporate society on Venus is civilized and hardworking, but also duplicitous and cutthroat; even the Venusians cannot agree on what they really want from the rest of the Solar System, beside money. Other minor space forces do exist, such as the Martians, Mercurians and the terrorist group known as STRIKE, but their navies are primarily defensive forces with little ability to project power beyond a very limited range. Players of **Lightning Strike** can choose from one of the three major Solar powers, building a fleet and taking it into battle to test the strength of their fellows or their enemies. Later, players will have the option to build fleets composed of units from the smaller (but no less dangerous) powers.

▼ WHAT'S DIFFERENT?

When deciding to create a second edition, many hard choices had to be made. What to keep? What to change? The rules are largely unaltered, but they have been reorganized to make it easier for new players to pick up the basics. The datacards have been completely revamped; now that the miniatures are available, it seemed only reasonable to make the packaging of the mini itself into a fully-functional game aid. The most major alteration is the addition of fleet list rules, which provide guidelines for building fleets as well as many options for weapons and equipment variations. Gone, however, are the various history segments and roleplaying integration rules; the history (for those with more interest in the various factions than merely blowing them up) is available in the many other **Jovian Chronicles** roleplaying supplements, and the roleplaying integration rules will be in the next edition of the **Jovian Chronicles RPG Rulebook** in much-expanded form. We also moved the timeline back to the familiar RPG setting; when the time comes for the storyline to return to the fire of the Edicts War, rest assured that it will be no small thing.

Although the rules changes are apparent in the new reference tables, experienced **Lightning Strike** players are still recommended to give the rules a quick read-through. Most currently-existing fleets will most likely conform to the new fleet list rules; only people who feel the need to field an army of nothing but snipers and battleships need worry. The game is now faster and less ambiguous, while still providing more strategic options than before. We hope you enjoy playing **Lightning Strike** as much as we enjoyed making it.

BOOK CONTENT ◀

Chapter 2, Basic Rules (page 14): This chapter introduce Players to the mechanics of **Lightning Strike**, and allow for fast games involving exo-armors, fighters and ships. Even advanced Players may wish to limit themselves to the basic rules when playing large battles or playing within a time limit. The Intermediate and Advanced rules presented later allow Players to add more tactical options to the game at the cost of speed of play. To play a single game, players will need to read the Perks and Flaws section (see page 60) and the fleet lists starting on page 74. To play a continued campaign, Players will also need to use the Campaign Rules, starting on page 48.

Chapter 3, Intermediate Rules (page 34): Unlike the Basic rules, which should be read and used in their entirety, these Intermediate rules are distinct and modular. Players may use none, some or all of them, leaving out the ones that are too time-consuming or complex. The difference between the Intermediate and Advanced rules is that the formers tend to modify the way the basic game is played, while the latters add extra facets that increase the numbers of way the game can be played. Use of any Intermediate rules should be agreed upon by all Players before the game begins; a note should be made of all the Intermediate rules that are in effect to prevent future disagreements while in play.

Chapter 4, Advanced Rules (page 40): The rules in this chapter complete the rules set for **Lightning Strike**. All of these rules are optional, and add new tactical options at the price of increased complexity. Some of these rules, however (notably the rules for Aces and Obstacles), play a significant role in the campaign game (see Chapter 5). Players should thus either agree not to use these rules or become comfortable with them before beginning a campaign.

Chapter 5, Campaign Rules (page 48): Even in the charged political climate of the 23rd century, outright warfare is often a logistical and economic impracticality. It's so much easier to send out a lone fleet, made as self-sufficient as possible, and tell its commander to wreak as much havoc as possible before coming home. If the fleet succeeds, they can be quietly welcomed back. If they fail, their actions can be loudly (if not necessarily believably) denied.

Each basic campaign focuses on two rival fleets, each one assigned to undertake operations in a certain area of the Solar System. Players will choose their fleets, maneuver them into a strategically advantageous position, and then fight it out on the tabletop.

Chapter 6, Special Abilities, Weapons and Equipment (page 60): This chapter contains rules for the special abilities listed on most units' datacards. Most weapons have abilities listed in their "Notes" column, and most vehicles have Perks and Flaws, which are traits that affect the vehicle as a whole. The game can be played without these special abilities (most of them are beneficial, so you really are not "cheating" by leaving them out), and beginning Players may wish to ignore the rules in this chapter until they are comfortable with the Basic rules in Chapter 2.

Chapter 7, Fleet List (page 74): It is said that diplomats use lies to make policies, while armies use honesty to enforce them. This chapter provides game-context descriptions, rules and guidelines for these tools of politics. Each one is different, but they all serve the same function for their respective nations: using guns, knives and bare hands, they act as the ultimate statement of truth, an unfettered declaration of mortal dislike.

Each fleet list provides a description of the various standard units and ships used by one of the military organizations in the Solar System. In this book, the three superpowers (Jupiter, Earth and Venus) are presented; fleet lists for other, smaller forces will make their appearance shortly. Each list also gives rules and limitations for building a fleet, and ends with a description of organizational and behavioral quirks.

1.2

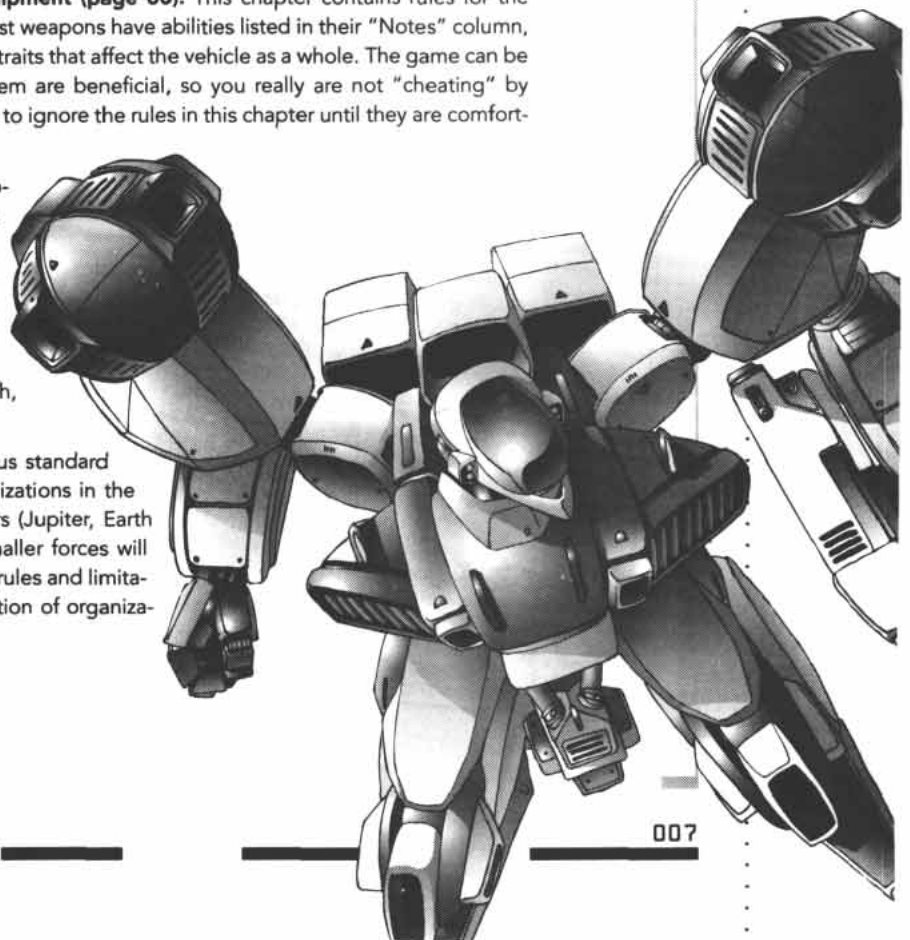



▶ WHAT YOU NEED TO PLAY

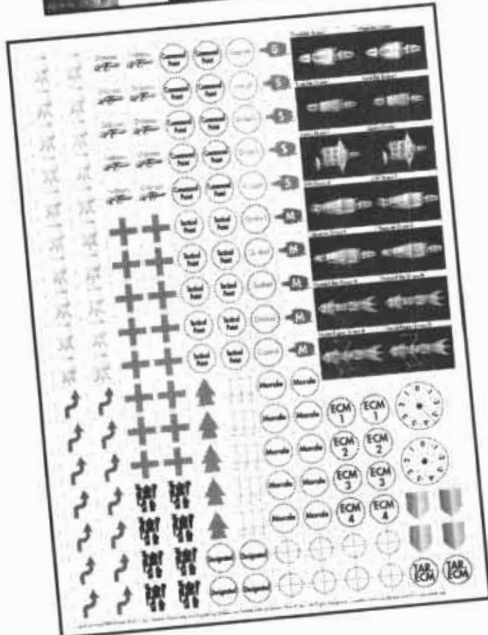
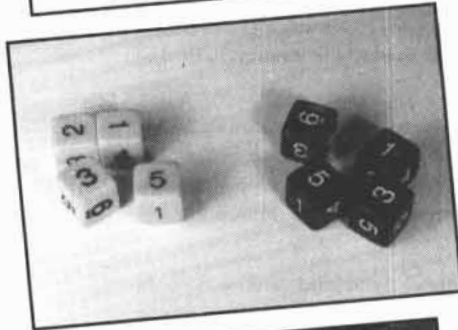
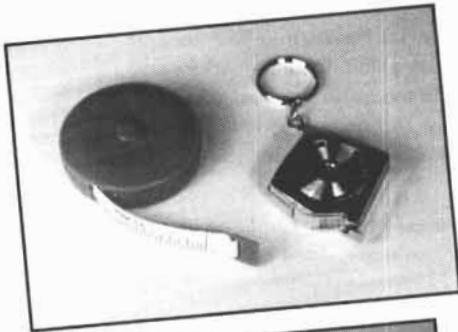

Miniatures: Lightning Strike is meant to be played as a tabletop miniatures game. Miniatures are available from Dream Pod 9, although many manufacturers also produce generic science-fiction miniatures that will also suffice (indeed, it is quite possible to play the game with nothing more than labeled counters or scraps of paper).

Ruler: a ruler or tape measure will be required to play the game. The units used in this rulebook are centimeters, but Players may use inches if they so desire (using inches will require more table space, but makes crowded close-range combat somewhat more manageable). An arc ruler, to measure firing arcs and turn radii, will also come in handy.

Dice: each player will need between two to four six-sided dice for making combat rolls. More is always better.

Playing Field: Lightning Strike is a tabletop game, and thus has no actual mapboard upon which to move the playing pieces. All that is really needed is a large flat surface and a tape measure or ruler, although many enhancements may be added to spruce up the field. For example, asteroids may be represented by pieces of foam, Styrofoam or by actual rocks. Small boxes or other containers can represent spaceborne structures, or purpose-built miniatures can also be used. Cotton can be used for dust or other particulate clouds. Minefields can be represented by cardboard disks of the appropriate diameter. See page 32 for more on terrain modeling. Other than these items, though, space is a pretty empty place and as such any plain surface will do.

▼ COUNTERS

This book includes a sheet with examples of the many counters that may be used in the course of a game. For large games, you may need to photocopy this sheet (or download and print the file from Dream Pod 9's website) in order to get extra counters (this is especially true of the counters required by the Advanced and Optional Rules).

Command Point Counters: these come in two varieties: Initiative and Tactical, and are given to Players to help them remember how many points they have left to spend. Tactical points are retained throughout the game until they are used, while Initiative points are discarded at the end of every turn if they are not used. See page 39 for more.

Overthrust Counters: used to mark a unit as having used Overthrust movement.

Aiming Counters: these counters are used to mark a unit that is Aiming.

Evasion Counters: similar in usage to Aiming Counters, these are used to signify that a unit is evading.

Damage Counters: there are two types of damage counters, both of which may be assigned to a single unit at once. Stunned units have sustained mild damage, while Crippled units have taken heavy hits and are noticeably weakened.

Missile Swarms: these counters are used to represent swarms of ship-launched missiles. They can be replaced by missile miniatures if the Players wish.

Avoidance Wheel: this is attached to a ship miniature's stand, and is used to denote the ship's current level of visibility.

Shield-Mode PDS Counters: these counters are used to mark a ship that has its Point-Defense System (PDS) in shield mode, in which the lasers watch a protective perimeter around the ship instead of actively shooting down opponents.

Vector Counters: these are used to mark a warship that has a vector independent of its current direction.

ECM Counters: these are placed on Units that are actively using ECM to block enemy command and control.

Ace Counters: these counters represent Ace-level pilots, and are placed next to the unit the Ace is piloting.

The other counter types are used with the Advanced Rules, and are explained elsewhere. These counters are: Ordnance, Targeted ECM, Cloak, Drone, Payload, Minefields and Shrouds.



BOOKKEEPING ▼

Each unit type in **Lightning Strike** has its own datacard that provides all of the information necessary to use that unit in gameplay. There are two types of datacard used in the game: Standard and Ship. One can either use the datacard reference sheets included in this rulebook, or keep a stack of the datacards that are included with each Jovian Chronicles miniature. If special equipment, like Missiles or Booster Pods are installed on a unit, the datacard can be altered to note this; otherwise, the datacard need never be written on, and a single datacard is sufficient to provide data for any number of that type of miniature, so long as they are all identically equipped. Blank datacards and other support material will be available as computer files of various types at Dream Pod 9's Web site (<http://www.dp9.com>).

The best way to use datacards, however, is to place them in a document binder with transparent plastic sleeves. Erasable markers, such as those pictured at right, can then be used to mark damage and carried ordnance directly onto the sleeve-protected datacards, without any permanent effects!

Keeping all the cards in one binder also makes them easier to organize and store. For example, a Combat Group (see page 13) can be stored in a single sleeve. Getting a fleet together is then a simple matter of looking through the binder and selecting battlegroups and individual ships. The task is made even easier if a slip of paper with the group's point value and other special data (such as earned experience and pilot skills) is slipped in one corner of the sleeve.

Binders and transparent sleeves can be found at the local office supply stores, but game stores are generally carrying them as well for game cards storage. The larger ship datacards will not fit those sleeves, but full page document sleeves or quarter-page photo sleeves will hold them perfectly (see pictures at right).

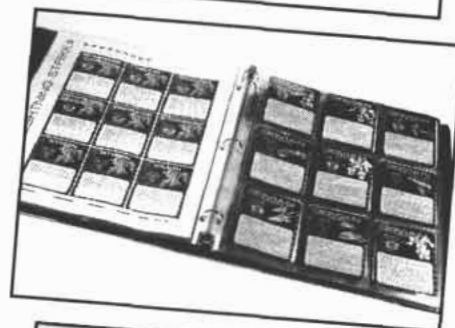

2.E.1



▼ STANDARD DATACARDS

The vast majority of datacards used in the course of a typical game of **Lightning Strike** will be of the **Standard Datacard** type. This type is used for anything smaller than a capital ship, and provides game statistics for either a single large vehicle or a squad of smaller units (such as spacesuited or power-armored troops). Standard data cards are divided into several distinct sections.

⊙ DATACARD IDENTIFICATION

IDENTIFICATION SECTION

The Identification section is the set of characteristics at the top of the card. These include the unit's **Name**, its **Threat Value** (abbreviated to TV) and three miscellaneous attributes. **Actions** denotes the number of Actions the unit has available when Activated, while **Electronics** is a composite of the unit's basic abilities to communicate with and sense other units. Size is used to determine how much space the unit occupies, and what it can hide behind.

MOVEMENT SECTION

Just below the identification section is the Movement section, which defines how far the unit may move each turn. There are usually two numbers here. The first number is the unit's normal **Movement Allowance**. The second number (if any) represents the unit's movement allowance when using an alternate movement scheme (e.g. Overthrust for exo-armors and fighters). Also in the movement section is a **Facing** notation, which describes what sort of turning characteristics the unit has (in this game, the possible Facing types are Exo-Armor, Fighter and Exo-Suit/Infantry).

WEAPON NAME

This gives a short description of what the attack actually consists of (generally the weapon's name).

ARC

Arc defines in what direction relative to the unit the attack may be used in. The most common arc is Forward (F), which is a one-hundred-eighty-degree arc centered on the front of the unit.

ATTACK SECTION

Located at the bottom of the card, the Attack section is a table that summarizes all of the forms of attack available to the unit, including the name of each weapon, its arc, range, accuracy, damage, type and any special abilities that it may possess.

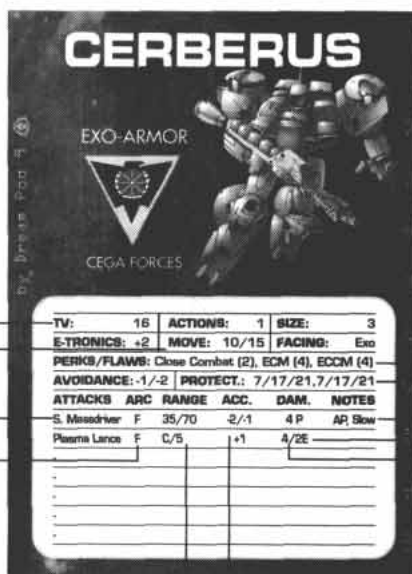

RANGE

Range defines how far away from the unit the attack may be used, and also defines a set of range bands in which the attack has varying levels of performance.

ACCURACY

Accuracy defines how frequently the attack hits its target. Accuracy may vary with range; if this is the case, each slash in the Range column corresponds to a slash in the Accuracy column.

DEFENSE SECTION

Beneath the movement section is the Defense section, which is arranged in a table format, and provides information regarding the unit's defenses against attacks coming from various arcs (in this game, the defensive arcs are simply Forward and Rear). For each arc, two values are given. **Avoidance** is a measure of the unit's ability to not get hit by an incoming attack, and takes the form of a modifier to the unit's defense rolls. **Protection**, on the other hand, approximates the unit's ability to survive after actually being struck by an attack, and is noted as three threshold numbers.

PERKS/FLAWS SECTION

The **Perks/Flaws** section is located on the right side of the data card. It lists any special characteristics the units may have, such as enhanced defenses against particular types of attack or close-combat abilities.

NOTES

Any special traits the attack might have, such as the ability to pierce armor or to hit multiple times, are listed here.

TYPE

Listed immediately after the Damage Multiplier, this is either a 'P' (Projectile) or 'E' (Energy) and denotes the actual form the attack takes when used.

DAMAGE MULTIPLIER

The **Damage Multiplier** defines how much damage the attack inflicts on its target. This number is multiplied by the Margin of Success of the die roll to obtain the final damage value. Damage may vary with range, just like Accuracy.

SHIP DATACARDS ▼

The **Ship Datacards** are, unlike the standard datacards, meant to be written on in the course of a game, reflecting the greater complexity of damaging large vessels. Thus, each ship in the game must have its own datacard, either collected from miniatures blister packs or photocopied from this book.

Ship Datacards are generally similar to standard datacards, though with some important differences:

DATACARD IDENTIFICATION ○

SHIP CLASS

Ship Class describes the ship's **Class Name** and **Type**.

THREAT VALUE (TV)

The **Threat Value** is used for single battles and campaigns. The number after the slash, if any, is the ship's Campaign Threat Value.

CREW LEVEL

In most cases, a ship's **Crew Level** will be 2/0, which means that it has a Skill Level of 2 and a Skill Bonus of 0. Over time, however, a ship's crew may grow more Skilled, which is why this entry is left blank for the Player to write in.

BASE VISIBILITY

This value is the ship's highest possible **Avoidance** number. A ship's Avoidance value will change throughout the game but may never go above this.

DAMAGE CONTROL

Damage Control represents the crew's ability to repair the vessel during the game. This entry also has checkboxes for recording damage (in this case, casualties).

ARC

Arc defines in what direction relative to the unit the attack may be used in. The most common arc is Forward (F), which is a one-hundred-eighty-degree arc centered on the front of the unit.

RANGE

Range defines how far away from the unit the attack may be used, and also defines a set of range bands in which the attack has varying levels of performance.

BACK

The back of a datacard can be used to keep track of any long-term campaign notes, if necessary.

TURNING

Turning serves a similar purpose to the "Facing" entry on standard data cards.

ACTIONS AND ELECTRONICS

Actions and **Electronics** are the same as on the standard data cards. However, note that both of these entries have two small checkboxes next to them, to keep track of which systems have sustained damage.

COMPONENTS

A warship is a very large unit made up of several components. All ships will have a **Main Hull** and **Drives**, but the presence of hangars and weapons will vary from ship to ship. Each component has its own Protection value, and checkboxes to keep track of damage.

COMPONENTS NOTES

Any special traits the component might have, such as the ability to pierce armor or to hit multiple times, are listed here.

ACCURACY

Accuracy defines how frequently the attack hits its target. Accuracy may vary with range; if this is the case, each slash in the Range column corresponds to a slash in the Accuracy column.

DAMAGE MULTIPLIER

Damage Multiplier defines how much damage the attack inflicts on its target. This number is multiplied by the Margin of Success of the die roll to obtain the final damage value. Damage may vary with range, just like Accuracy.

CAMPAIGN NOTES

Resupply/Repair and **Fleet Maneuver** values are detailed in the Campaign Rules chapter on page 48.

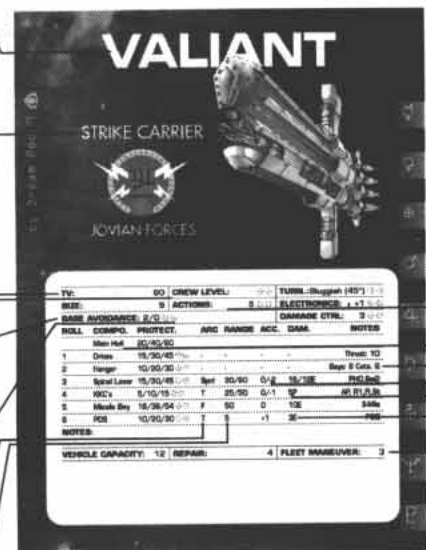

NOTES

This section describes any special rules that apply to the ship, either because of its design or because it has added equipment or an Ace crew.

TYPE

Listed immediately after the Damage Multiplier, this is either a 'P' (Projectile) or 'E' (Energy) and denotes the actual form the attack takes when used.



► CORE GAME CONCEPTS

This section contains the basic principles that **Lightning Strike** is built on. At its root, the game is a rather more complex version of chess, in which each unit has certain abilities, no one unit is overpowering or undefeatable, and coordinating a single, skillful attack is of far more value than simply lashing out with all guns blazing. After Players are comfortable with the Basic rules, they can read through the Intermediate and Advanced rules for even more game options.

▼ SCALE

Each game turn represents about 30 seconds. Each centimeter on the tabletop represents approximately 500 meters. The scales of the counters and miniatures are not "accurate;" if they were actually in scale with the playing field, they would be practically microscopic! Likewise, the scale of the available Jovian Chronicles miniatures is, by necessity, inconsistent. The exo-armors and fighters are 1/500 and the ships are 1/5000.

To look at it another way, the player is seeing the same view an admiral would see on his or her battle display, with all the units enlarged and labeled for easy identification. The actual unit only occupies the centerpoint of the miniature, and its range to other units is measured from the center of its base. Any combat activity (shooting, line-of-sight, taking cover, etc.) is also measured and dealt with from this centerpoint, with the exception of close combat, as explained later. The rest of the model, as far as the combatants are concerned, does not exist. It is there purely for the benefit of the player/admiral (and any onlookers).

► UNIT TYPES

In the **Lightning Strike** rules, a unit is any single stand (usually, but not always, with one miniature atop it). There are four major unit types. Exo-armors, fighters and exo-suits are collectively described as Standard Units, while large spacecraft are grouped in the Spaceship category. Standard units are distinguished by different modes of movement and combat; Spaceships stand out from Standard units because of their complexity and breadth of abilities.

An **exo-armor** is a large (fifteen meters tall, on average) and very expensive humanoid machine that is designed for close combat and dogfighting. First fielded by the Jovian Confederation in 2169, exo-armors (not to be confused with exo-suits, which are described below) have excellent maneuverability and defenses, but only average linear acceleration. Not quite the kings of the battlefield, they are still the closest things to reigning princes as far as the 23rd century is concerned.

The latest descendants of the atmosphere-bound war machines that fought for supremacy on Earth in centuries past, the **fighters** of the Solar Nations continue to perform traditional roles of reconnaissance, bombing and interception at budget prices. While exo-armors have taken over the arena of close-quarters dogfighting, fighters have both the acceleration and firepower to outflank and outshoot exo-armors, given half a chance. Their simpler construction also makes fighter much more adaptable in terms of payload and modifications.

Barely one step up from basic infantry, the **exo-suit** is essentially an armored spacesuit equipped with artificial muscles for enhanced strength and thruster pods for limited space mobility. Singly, an exo-suit poses little threat to a larger-type unit. In groups, however, the massed firepower of their small-but-effective anti-armor weapons can bring down even the mightiest exo-armor or fighter, and their small size makes them irritatingly difficult to hit. Exo-suits are also feared by warship crews, due to their deadly effectiveness as boarding parties. In **Lightning Strike**, exo-suits operate in squads of three to six 'suits; each plastic miniature base represents one squad, regardless of the actual number of exo-suit miniatures that are on the stand.

A **spaceship** is any space vessel equipped for long-term operation and mobility away from a base or port. Ranging in size from tiny corvettes to the mighty battleships and supercarriers of the Solar Nations' navies, ships serve as mobile hangars and repair centers for fighters and exo-armors, as well as bringing heavy support firepower to the battlefield. Battles between warships take place on a completely different level from the smaller machines flitting about around them; warships duel in a slow, graceful ballet of move and countermove that relies more on forethought and careful analysis than good aim and lightning reflexes.

VARIABLE UNIT CHARACTERISTICS ▼

Each unit can possess abilities or traits that are not noted on its datacard. Its Group and Crew Level are the two most common ones (the full game effects are explained in the Basic Rules chapter, page 14).

A **Group** is simply a number of units working together, much like the members on a football team. The purpose of Grouping in the basic rules set is to determine which units are able to combine attacks with each other. All units in a Group move at the same time during a game turn. Independent units may move independently but cannot effectively combine attacks, while larger Groups must move together and thus lose some tactical flexibility in exchange for massed firepower. Each of the three fleets presented in this book has different rules for Grouping; see the Fleet List chapter (page 74) for more information. Since there is no restriction on how far units in a single Group may be from one another, one must make it easily distinguishable which Group a unit belongs to: distinctive paint schemes, for example, or colored paper clips or slips of paper attached to the miniatures' bases.

Each unit has two unlisted attributes, a **Skill Level** and a **Skill Bonus**. In the basic game, all units have a Skill Level of 2 and a Skill Bonus of 0. This simply means that in combat, they roll two dice for Actions and defense, with no inherent modifiers. These are referred to as Standard Pilots (or, in the case of ships, standard crews). The advanced rules section provides rules on how to use pilots and Groups with higher or lower Skill Levels and Skill Bonuses. The ship data card has a blank space for recording crew level, if necessary.

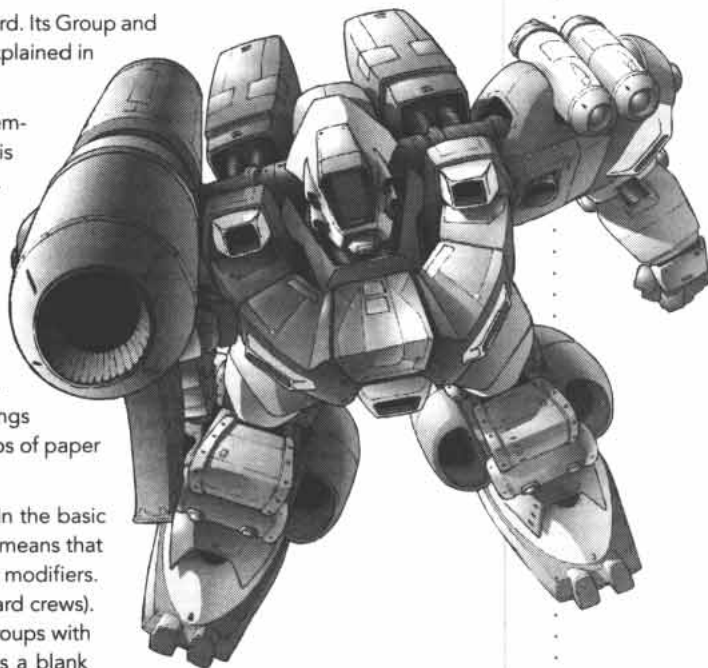

DICE AND DICE ROLLING ▼

Several six-sided dice are needed to play **Lightning Strike**. When two or more dice are rolled simultaneously, their results are not added together. Instead, the highest value rolled is considered to be the outcome of the die roll. If more than one '6' is rolled, each extra '6' adds one (1) to the total of the die roll. Thus, if two dice are rolled and come up a '6' and a '5,' the result is six, not eleven. If both dice come up '6,' then the result is seven (6+1). If every die rolled turns up a '1,' the die roll is a Fumble and an automatic failure, regardless of any modifiers.

Modifiers can be added to or subtracted from the result of the die roll. A +2 modifier would add two to the result of a roll, for instance, while a -3 modifier would subtract three from the result. The minimum result after modifiers is zero. If negative modifiers lower the total below zero, the final result is always zero.

Most of the rolls made in **Lightning Strike** are opposed rolls, with one Player actively rolling against another. If a Player's die roll is greater than his opponent's, the test succeeds. The degree of success or failure is determined by the **Margin of Success (MoS)**, a value equal to the difference between the two rolls. The defender always wins draws.

In some cases, a Player must roll against luck or nature, in which case a set target number, or **Threshold**, is assigned. For instance, the Threshold to see if a ship successfully Spoofs is 3. A roll using a number of dice equal to the Skill Level of the unit is made: if the highest result is above 3, the roll succeeds; otherwise, the roll fails. For simplicity, all such rolls are referred to as Skill rolls. In the game, most pilots are Level 2 pilots, with Skill Levels of 2 and Skill bonuses of zero. This means that whenever a Skill test must be made for a unit, two dice are rolled, with no initial modifiers.

Unless otherwise mentioned, all die rolls in **Lightning Strike** work in this way. Occasionally, other rolls need to be made, not based on any unit's Skill level, but simply to randomly determine game events such as returns from off the playing field or warship reactor explosions. These rolls are usually performed on one die.



▶ THE TURN SEQUENCE

2.1

Lightning Strike is played as a series of turns during which both Players may act. In each turn, Players will roll off to determine initiative. The Player who wins initiative decides which Player will go first in each of several subsequent phases. When all Players have completed their actions for the turn, another turn begins, with a new roll for initiative.

▼ INITIAL SETUP

2.1.1

Players set up on the tabletop according to the dictates of the scenario. In a simple shootout between two forces, Players should take turns setting up on opposite sides of the playing field (if necessary, determine randomly which Player places the first unit). All ships or Groups of ships should be placed first, starting within twenty centimeters of their owning Player's edge of the field. Each ship must have a way of tracking its Avoidance. Avoidance counters may be photocopied from the counter sheet and punched so as to spin freely around the miniature's base; painting the Avoidance numbers directly on the base and using a rotating pointer is another option.

After all ships are placed (or if there are no ships being used in the battle), Players alternate placing Groups of fighters, exo-armors or other units on the field. Depending on the scenario and the Players' choices when building their fleets, some of the units on the table may start the game with various counters. Unless specifically forbidden by the scenario, units may start the game with Special Movement counters (Overthrust, Evasion, Aiming or Vector), and ships may start at maximum Avoidance.

▼ THE GAME TURN

2.1.2

In each turn, Players roll off to determine initiative. The Player who wins initiative decides which Player will go first in each subsequent phases. When all Players have completed their actions for the turn, another turn begins, with a new roll for initiative. The table below summarizes the various phases and steps that make up each game turn.

▣ GAME TURN SUMMARY

INITIATIVE PHASE	Roll Initiative
	Players assign PDS mode for all ships
FIRST SHIP PHASE	Players alternate moving independent (ungrouped) ships.
	Players alternate moving Groups of ships.
	Players alternate moving any independent ships that did not move before the Grouped units.
MAIN PHASE	Players alternate taking Actions with independent (ungrouped) standard units.
	Players alternate taking Actions with all standard-unit Groups.
	Players alternate taking Actions with any independent units that did not act before the Grouped units.
SECOND SHIP PHASE	Players alternate taking Actions with independent (ungrouped) ships.
	Players alternate taking Actions with ships.
	Players alternate taking Actions with any independent ships that did not act before the Grouped units.
END PHASE	Resolve warship missile launches.
	Resolve warship missile hits.
	Roll for catastrophic damage on warships.

◇ THE INITIATIVE PHASE

Each Player rolls two dice; high roll wins, reroll ties. The winner gains initiative for one full turn. At the beginning of the First Ship Phase, the Main Phase and the Second Ship Phase, the Player who has initiative chooses which side must go first (if there are more than two Players, the winner of initiative decides the order in which the Players will go). The winner of initiative may make different play order choices for each of the three phases. In the Initiative Phase, Players may also switch PDS modes. PDS is explained in further detail in the Perks and Flaws section (page 60).

THE FIRST SHIP PHASE ◇

In this phase, ships may move, with the winner of the initiative choosing which side will go first.

- 1) The first Player may move one of his independent ships (i.e. single ships that are not in a Group). Each subsequent Player, in turn, may move one independent ship; play then returns to the first Player. When all Players either do not wish to move an independent ship, or have none left to move, go to the next step.
- 2) The first Player may move one of his ship Groups. Each subsequent Player, in turn, may move one ship Group; play then returns to the first Player. When all Players either do not wish to move a ship Group, or have none left to move, go to the next step.
- 3) The first Player may move one of his independent ships that has not already moved this Phase. Each subsequent Player, in turn, may move one independent ship that has not already moved this Phase; play then returns to the first Player. When all Players either do not wish to move an independent ship, or have none left to move, the First Ship Phase is over. Once a Player elects not to move a ship or Group, he may not move another ship or Group until the next step of the Phase.

THE MAIN PHASE ◇

The Main Phase is where all exo-armors, fighters, exo-suits and infantry move and act. The term **Activation** is used to refer to a unit's movement and actions, when it is actively doing something during the Main Phase, as opposed to sitting around. A unit's Activation comprises the period of time between a Player's choosing it out of an activated Group and it finishing any movement or Actions it needs to execute for the turn; this may be, if the Player desires, no movement and no action at all.

At the start of a unit's Activation, the Player may choose to retain, add or remove an Overthrust counter from the unit. The unit then moves or acts as its owning Player desires. At the end of a unit's Activation, any unused Actions are lost. A standard unit has one Activation each turn, and may thus only move its full MP allowance once per turn. When a Group is activated, all units in that Group are activated, in any order, one after the other, and must finish their Activation before the next Player activates a Group of his own.

In this phase, standard units may move, with the winner of the initiative choosing which side will go first.

- 1) The first Player may activate one of his independent units (i.e. single units that are not in a Group). Each subsequent Player, in turn, may activate one independent unit; play then returns to the first Player. When all Players either do not wish to activate any more independent units, or have none left to activate, go to the next step.
- 2) The first Player activates one of his standard-unit Groups. Each subsequent Player, in turn, activates one standard-unit Group; play then returns to the first Player. When all Players either do not wish to activate any more standard-unit Groups, or have none left to activate, go to the next step.
- 3) The first Player activates one of his independent units that has not already been activated this Phase. Each subsequent Player, in turn, activates one independent unit that has not already been activated this Phase; play then returns to the first Player. When all Players either do not wish to activate any more independent units, or have none left to activate, the Main Phase is over.

Once a Player elects not to activate a unit or Group, he may not activate another unit or Group until the next step of the Phase.

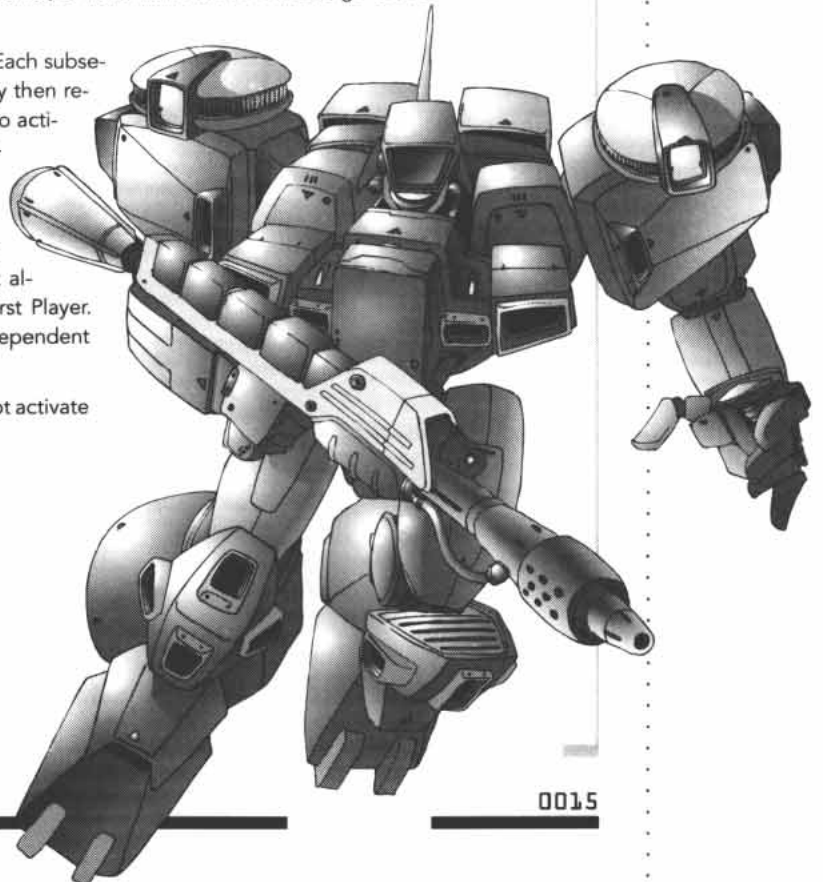

◇ THE SECOND SHIP PHASE

The Second Ship Phase is where all ships take their Actions. Each ship has several Actions, which can be used to attack, move or perform other activities. A ship's Activation has exactly the same definition as a standard unit's Activation. At the end of a ship's Activation, any unused Actions the ship has remaining are lost. When a Group is activated, all units in that Group are activated, in any order, one after the other, and must finish their Activation before the next Player activates a Group. The winner of initiative decides which side will go first.

- 1) The first Player may activate one of his independent ships (i.e. single ships that are not in a Group). Each subsequent Player, in turn, may activate one independent ship; play then returns to the first Player. When all Players either do not wish to activate any more independent ships, or have none left to activate, go to the next step.
- 2) The first Player activates one of his ship Groups. Each subsequent Player, in turn, activates one ship Group; play then returns to the first Player. When all Players either do not wish to activate any more ship Groups, or have none left to activate, go to the next step.
- 3) The first Player activates one of his independent ships that has not already activated this Phase. Each subsequent Player, in turn, activates one independent ship that has not already activated this Phase; play then returns to the first Player. When all Players either do not wish to activate any more independent ships, or have none left to activate, the Second Ship Phase is over.

Note that once a Player elects not to activate a ship or Group, he may not activate another ship or Group until the next step of the Phase.

◇ THE END PHASE

The End Phase is very important for warships, but less so for other units. Initiative does not matter in the End Phase; all events in each step are considered to be simultaneous.

- 1) All Players announce warship missile attacks and make lock-on rolls.
- 2) All incoming warship missile attacks roll to hit their targets.
- 3) All ships that are not visible to any enemy gain +1 Avoidance.
- 4) All ships in danger of exploding roll for Catastrophic Damage.

Once the End Phase is done, the next turn begins.

◇ ENDING THE GAME

A game may end when one side has completely cleared all opponents from the table, or when all sides but one concede victory. Depending on which scenario (if any) is being played, other conditions for victory may also exist, adding to or replacing the basic goal of completely destroying one's opponent(s).

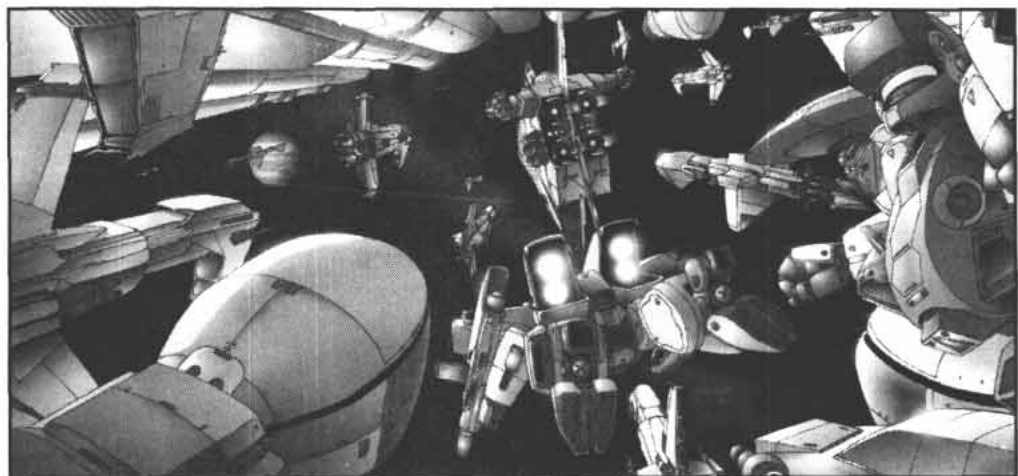

MOVEMENT ◀

Each unit has a Movement entry on its datacard. This is the basic distance (in centimeters) that the unit may move each turn. Most units will have two types of movement, to simulate differing goals on the battlefield; these will be described in further detail below. All units may only move once per Phase; since ships have two Phases (First and Second), they may move twice in a turn, if they so desire (once in each Phase).

As stated earlier, the scale of counters and miniatures in **Lightning Strike** is much larger than the scale of the battlefield itself. As a result, each unit occupies, in 'reality,' much less space than its associated counter does. Thus, units may move over and through each other without harm, with effectively no chance of a collision unless one is intended (see page 45 for ramming rules). Units may also end their movement anywhere, even atop other units, although this may get awkward when dealing with the miniatures. It is almost always sufficient just to place such miniatures next to each other.

A unit that leaves the edge of the playing area is not necessarily destroyed, but is considered to have retreated from battle and is immediately out of the game. Only if all Players agree, or a particular scenario demands it, should exceptions be made.

EXO-ARMORS ▼

An exo-armor may, during its Activation, move anywhere within a circle centered on its starting position in that turn and whose radius in centimeters is equal to the amount of movement the exo has available that turn. For instance, an exo with 10 cm worth of movement allowance that starts its Activation at point A may end up anywhere within 10 centimeters of point A. However, its path may be in any direction and in any shape; if a Player wants an exo-armor to move in circles for an entire turn, then that is what the exo will do. The exo-armor's facing is independent of its movement; the exo may fly 'backwards' for the entire battle, if its owner so desires. The only purpose of facing for an exo-armor is to determine where the pilot is focusing attention and hence which side is to be considered the 'blind' (or rear) side.



It should quickly become apparent that it is very difficult indeed to halt an exo-armor that does not want to stop, since it can simply edge out of the way of any obstruction. Exo-armors pay no movement allowance for facing changes, and may turn to face in any direction every time they move. An exo-armor must, however, have a definite facing at all times; if, for instance, it is being attacked from two sides, it cannot face both directions at once!

If an exo-armor is attacked while it is not acting, then its current facing is used for targeting purposes. At the end of its Activation, an exo-armor may be turned to face any direction, and will remain so until its next Activation.

This may seem confusing at first, since the exo's actual position during its Activation is rather abstract; it is somewhere within its sphere of movement, but where exactly varies depending on where the exo uses its Action and what path it takes to its destination. It is, for instance, entirely possible for an exo to move all the way to one edge of its 'circle,' fire off an attack, and then immediately zoom off to the opposite edge of the circle before ending its Activation. Once its Activation is over, however, the exo's position and facing are fixed until its next Activation. It is helpful for Players to trace the path of their exos' movements, always keeping in mind the exo's distance from its starting point. As long as the exo does not stray out of its 'circle' during its Activation, Players are encouraged to come up with creative ways of moving their exo-armors.

An exo-armor may use **Overthrust** movement to increase its movement allowance. The use of Overthrust movement must be declared at the start of the exo-armor's Activation, and an Overthrust counter is immediately placed on the unit. The unit's Overthrust movement allowance is the number after the slash on its datacard's movement section.

Overthrust movement is very strenuous on an exo-armor's structure and balance, and its Actions are accordingly more difficult to accomplish effectively. Attacks and other Actions are made with a -3 modifier until the start of the exo-armor's next Activation (this status is denoted by the Overthrust counter). Otherwise, the movement style is exactly the same as normal movement.



2.2.2

▼ EXO-SUITS

Exo-suits travel in squads of several 'suits. Each exo-suit miniature base represents a full combat squad, and the exo-suit datacards likewise describe the stats for a full squad of four to six men. Exo-suits have no facing: every side is considered to be the 'front,' even when the squad is attacked from multiple sides (exo-suit squads have identical front and rear defense stats). Otherwise, their movement is exactly the same as exo-armor movement, following the same system of normal and Overthrust movement, albeit with smaller MP allowances to reflect their lower reaction mass reserves.

2.2.3

▼ FIGHTERS

Under normal movement, a fighter may move a number of centimeters equal to its basic movement allowance (the number before the slash on its datacard). However, fighters, being less maneuverable than exo-armors, must pay for facing changes. A fighter under normal movement may make one turn of up to ninety degrees at any point in its phase for free; any additional turns past that, up to and including full about-faces (180°), cost half of the fighter's movement allowance.

For example, a Lancer has a basic movement allowance of 12. If it only turns ninety degrees during its phase, it may move 12 centimeters. If, however, it wants to turn around completely, it may only move 6 centimeters.

A fighter cannot move in any direction like an exo-armor, but must instead move in the direction in which its nose is facing. Thus, care must be taken to properly trace a fighter's movement, since its position and facing are always solid values, unlike the more abstract systems used by exo-armors.

Fighters are lousy close combat combatants, as shown by their poor performance under normal movement. Where fighters excel, however, is when throttles need to be opened wide and blazing acceleration is needed. A fighter using Overthrust movement uses the movement allowance value after the slash on its datacard's movement section. The fighter may make only one turn of up to ninety degrees at the start of its phase. It may make no other turns at all. An Overthrusting fighter must also move a minimum distance equal to its normal MP allowance. Fighters have no penalties for attacking or performing other Actions while using Overthrust movement, and so do not need to be marked with Overthrust counters.

○ STANDARD UNIT MOVEMENT EXAMPLE

An exo-armor with a Movement of 10/20 starts its Activation behind a piece of cover (say, an asteroid). Its controlling Player uses a ruler to measure a 10-centimeter-radius circle around the exo-armor miniature; until the exo-armor finishes its Activation, it can be anywhere inside this circle. So, the Player moves the exo-armor around the asteroid, 10 cm toward an enemy, and uses the exo-armor's Action to attack. After the attack, the Player moves the exo-armor back behind the asteroid, and ends the unit's activation; at this point, the exo-armor's position and facing become fixed again. If he wanted, the Player could also move the exo-armor 10 cm back from where it started, even though it moved 10 cm forward to attack. If the player had chosen to Overthrust, he could have moved the exo-armor anywhere inside a 20-centimeter-radius circle, but its attack would have had a -3 modifier.

An exo-suit squad with a Movement of 5/10 starts its Activation. It can be anywhere within a 5-centimeter-radius circle around the center of the miniature stand until the squad finishes its Activation. After the attack, the squad can move as far back as it needs too, so long as it stays within the circle. Once it is done moving, its position becomes fixed again. Exo-suits have no facing — every side is considered to be the 'front' — so its final facing does not matter. If the Player had chosen to Overthrust, he could have moved the exo-suit squad anywhere inside a 10-centimeter-radius circle, but its attack would have had a -3 modifier.

A fighter with a Movement of 15/45 starts its Activation behind an asteroid, facing the asteroid. The Player decides to use normal movement. He must first turn the fighter so that it won't fly into the asteroid. He can turn up to ninety degrees, and does so. He moves the fighter 8 centimeters, and then decides to turn the fighter again. Since he has turned more than 90 degrees, his fighter must give up half its Movement allowance. Since half of 15 is 7.5, rounded up to 8, the Player cannot move the fighter any more this turn, since it has already moved 8 cm forward. If the Player had chosen to Overthrust, the fighter could have turned 90 degrees and then moved up to 45 cm straight forward, but it would not have been able to turn again, because Overthrusting fighters only get to make one turn.

SPACESHIPS ▼

2-2-4

Almost all ships are constructed around a similar design principle. A large array of primary engines is placed at the end of a long main hull, along which cargo modules, habitat rings and weapons emplacements are mounted. Small clusters of maneuvering thrusters are scattered all over the hull and are used to turn or roll the ship. This configuration allows the ship to accelerate powerfully "forward," but in order to decelerate or change direction, the ship must use its maneuvering thrusters to come about.

Each ship has listed on its datacard the available thrust from its **Drives** section. This thrust value is the number of centimeters the ship may move, straight ahead, each time it is allowed to move. A ship may move once during the First Ship Phase, and may also spend one Action to move a second time in the Second Ship Phase. A ship may not spend more than one Action to move in the Second Ship Phase.

A ship can change facing by a certain amount each turn, and may do so before, during or after its forward thrust. If a ship changes facing, it must "pay" for the facing change with half of its normal forward thrust. There are four classes of ship Turning:

Nimble: each turn, this ship may change facing up to 180° at the cost of half its movement allowance.

Average: each turn, this ship may change facing up to 90° at the cost of half its movement allowance.

Sluggish: each turn, this ship may change facing up to 45° at the cost of half its movement allowance.

Immobile: this ship may not change facing at all. It either sits completely still, or moves in a single direction for the entire game.

A ship cannot change facing more than once a turn. Even if the ship uses an Action to move in the Second Ship Phase, it still may not change facing a second time. A ship may, however, choose to wait until the Second Ship Phase to make its facing change.

For example, a Valiant-class carrier has 10 cm of movement allowance and an Average Turning Type. In the First Ship Phase, it decides to change facing. It may turn up to ninety degrees, but may only move forward half of its movement allowance (5 cm). After it moves and changes facing, its Avoidance is reduced by 1 (see Avoidance, page 22). In the Second Ship Phase, the Player spends an Action to apply more thrust (which will again reduce the ship's Avoidance by 1). The Valiant may move forward 10 cm, but it may not change facing, because it has already done so this turn.

SHIP TURNING □

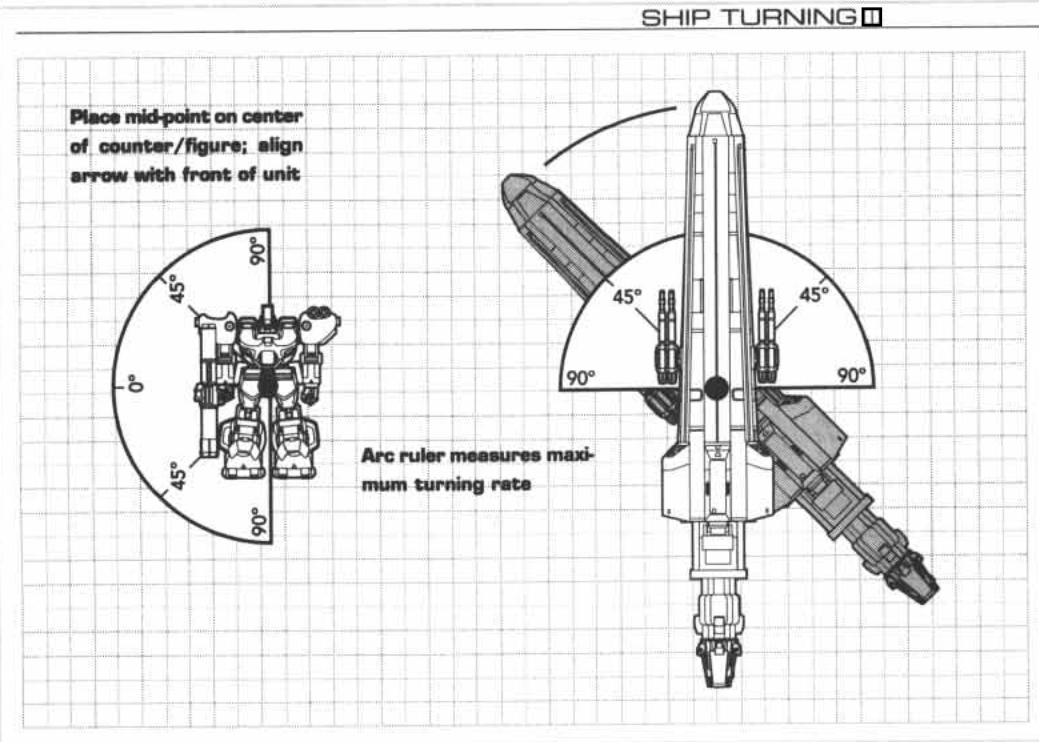



▶ ACTIONS

At any point in its Activation (i.e. before, during or after its movement), a standard unit may use any or all of its **Actions**. Actions are most often used to attack other units or repair damage (this is a wargame, after all), but some other options may be available to certain specially-equipped units (see *Perks and Flaws*, page 60). The number of Actions a unit may spend each turn is listed at the top of its datacard, under 'Actions.' For most non-ship units, this number is one, although some units (like CEGA's Wraith fighter) have two or more.

Ships have several Actions, and can use them for a number of purposes, not just attacking. The Player must choose what Actions a ship will take; very seldom will a ship be able to do all the things it wants to do.

▼ SHIP ACTIONS

Each ship in the game has a basic number of Actions, noted on the ship's datacard. Unlike most smaller units, like exo-armors and fighters, this number is usually quite large, and represents a ship's large crew and multiple automated systems.

Several types of Action are available to ships and may only be used in the Second Ship Phase unless a Command Point is used. With the exception of the Thrust Action, any Action may be taken more than once in a single turn, and the Actions may be taken in any order.

The five possible Actions for ships are:

Damage Control: this Action represents crewmembers being called away from normal duty stations to assist in repairing the ship. The ship may immediately roll its full available damage control dice complement against a Threshold of 3. The Margin of Success of the Roll is the number of damage boxes on the datacard that may be repaired (erase the marks in those checkboxes). A failed or fumbled roll has no result.

Fire Weapons: this rather self-explanatory Action allows a ship to fire any or all of its weapons. Each weapon may only fire once per use of this Action, but as many weapons as the Player desires, up to and including the vessel's entire complement, may fire each time this Action is used. Note that weapons with the Power-Hungry characteristic, when fired, restrict the number of other weapons that may be fired in the same Action (see page 64).

Ping: the ship turns on its active sensors for a few moments in an attempt to "light up" another ship. Select a target ship. For ships, the range of a Ping is essentially unlimited, but is limited by line-of-sight (it is not possible to ping a ship that is hiding behind an asteroid, for instance). Each ship makes a Skill test, modified by its Electronics rating. If the defender wins, there is no effect. If the attacker wins, the defender's Avoidance is reduced by 2. No matter what the result of the roll is, the attacker's Avoidance is reduced by 1. If the attacker fumbles, its Avoidance is reduced by 2 instead of 1.

Spoof: this Action represents the ship's crew devoting power, resources and attention to misleading enemy targeting systems by various electronic and physical means (balloon decoys, flares, etc.). Make a Skill test using the ship's Crew Level against a Threshold of 3. If the roll fails or fumbles, nothing happens. If the roll succeeds, increase the ship's Avoidance by the roll's Margin of Success.

Thrust: in the First Ship Phase, every ship gets the opportunity to use its movement allowance (apply thrust) without expending Actions. If this proves insufficient, the ship may spend one of its Actions in the Second Ship Phase to move a second time (this will again reduce the ship's Avoidance by one). This Action may only be taken once per turn.

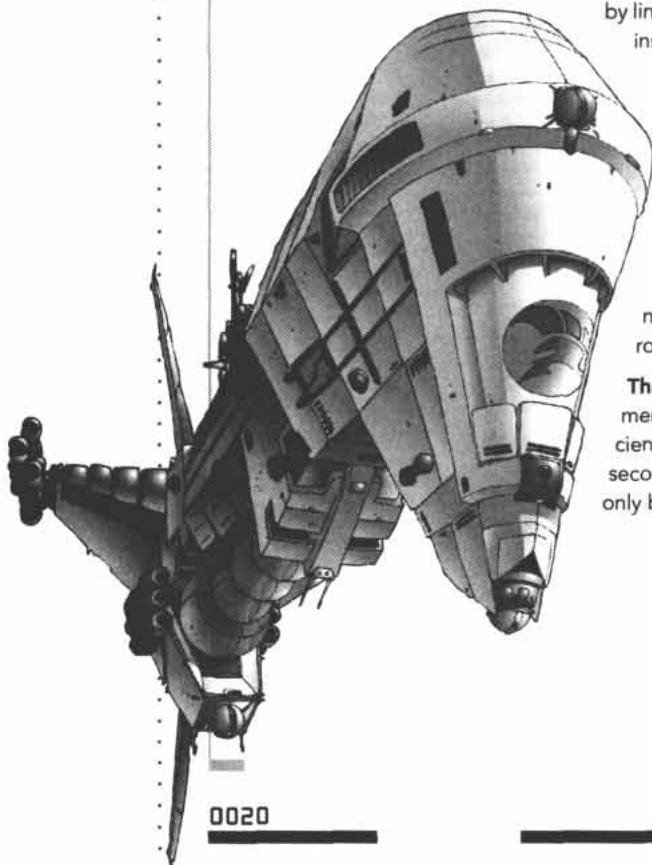

0020

2.3.3

2.3.1

COMBAT ◀

The basic goal of maneuvering in battle is to get in a position to attack (and hopefully destroy) the enemy. In **Lightning Strike**, there are two basic styles of attack. Standard units dash about to make single, well-placed strikes on their opponents, while warships launch vast swarms of missiles, beams and hypervelocity slugs at one another. This section describes the procedures for both types of combat.

All units in the game are assumed to have enough ammunition for their weapons to last through a battle. Only some special weapons (like Drones and bomber ordnance) require ammunition to be tracked; rules for such weapons are provided with their descriptions. Units are also assumed to have sufficient fuel to last through the battle. Fuel and ammunition considerations do come into play in Campaign games, but these are dealt with outside of the main tactical **Lightning Strike** rules.

LINE-OF-SIGHT ▼

Space is big, extremely so. There is seldom any cover worth speaking of, and it is generally not hard to get a clear shot at a target, provided one knows where it is. **Line-of-Sight (LOS)** is defined as the knowledge a unit has of the location of its target, and the implied ability to launch an attack against the target. If a unit does not have LOS because its target is hiding behind a rock, dust cloud or another unit, then the target may not be attacked until LOS is established. LOS can be blocked only under certain circumstances. In most situations in **Lightning Strike**, any unit on the map will be able to see any other unit on the map.

LOS is blocked if the target is in base-to-base contact with an intervening piece of terrain or a similarly intervening other unit whose Size is equal to or greater than the unit being targeted. Note that base-to-base contact is necessary for LOS to be blocked. If the unit the target is in base-to-base contact with is actively engaged in close combat with the target, and the involved units are the same size, then any weapon hit has an equal chance of striking either unit.

Thus, an exo-armor (Size 3) could hide by placing itself so that a Size 3 or larger object or vehicle is between it and its assailant. If it were in close combat with another Size 3 unit, it would run a fifty-percent chance of getting hit by any incoming fire (with its opponent getting hit the other fifty percent of the time). In close combat with a Size 2 exo-suit, it would gain no cover at all. On the other hand, it would gain complete cover from a Size 8 warship it was in close combat with, as long as, of course, it remained behind the warship and in contact with the warship's base. Depending on what Intermediate or Advanced rules are in effect, there may be other instances in which LOS may be blocked, but in the Basic rules, the concept is that LOS is never blocked unless the target in question is in base-to-base contact with the intervening object(s).

LINE OF SIGHT EXAMPLES ◉

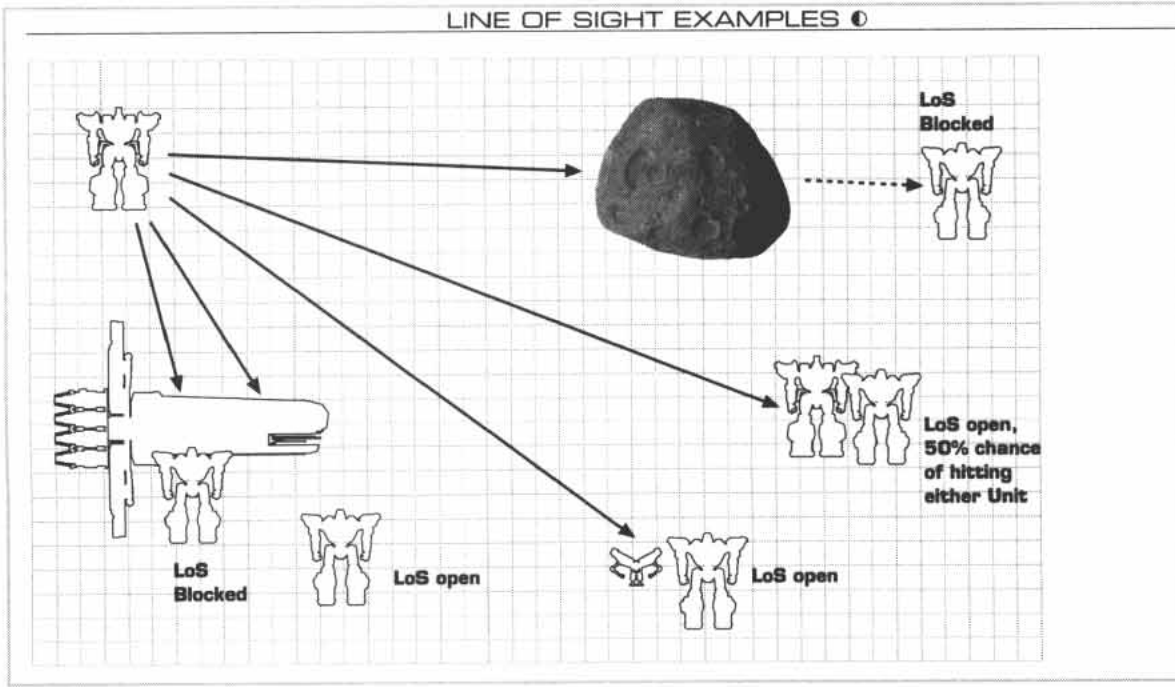

2.4
2.4.3

▼ RANGE

Before an attack is made, the **Range** between the attacker and the target must be determined. Simply measure the distance in centimeters from the center of the attacker's base to the center of the target's base. Players may measure range at any time. Units in physical or base-to-base contact are considered to be in close combat, and the range between them is considered to be zero (or "C" on the datacards).

The Range column of the attack box on the datacards provides range information for attacks in one or more range bands. These bands correspond with the bands that are in the Accuracy and Damage columns, giving an attack different Accuracy and Damage scores depending on the range. For instance, the Pathfinder Alpha's particle cannon has three range bands: C, 10 and 25, separated by slashes. In the Accuracy column, the three Accuracy values, +1, +1 and 0 are also separated by slashes, as are the three Damage values in the Damage column. Thus, at a range of 'C' (close combat, or physical contact), the particle cannon has an Accuracy of +1 and a Damage Multiplier of 4. Out to ten centimeters, the particle cannon still has a +1 Accuracy, but its Damage drops to 3. Finally, at ranges between 10 and 25 centimeters, the cannon's Accuracy drops to zero and its Damage drops again, to 2. The particle cannon cannot attack beyond 25 centimeters.

If a weapon does not have a 'C' as one of its range bands, then it cannot be used in close combat. Such a weapon may attack as long as there is any space (even a fraction of a centimeter) between the attacker's counter and the target's, but once the two are in physical contact, it may not attack at all. This represents weapons that have a minimum arming distance, like long-range missiles, or especially heavy or unwieldy weapons that cannot be swung around to bear on a nearby target.

▼ AVOIDANCE

All units have an **Avoidance** value, which defines their ability to dodge, hide or otherwise avoid being struck by an attack. Standard Units have fixed Avoidance values, which act as modifiers applied to all of that unit's defense rolls. Ships, on the other hand, have Avoidances that can rise and fall from moment to moment, depending on the ship's actions and the actions of others.

Being unable to nimbly dodge incoming fire like exo-armors, ships must rely on deception and stealth to avoid being hit by enemy fire. All warships have extensive arrays of electronic spoofers and decoy generators, designed to mask the ship's exact location and make targeting difficult for enemy gunners. While it is impossible to make a ship invisible, all that is really required is to persuade an enemy that his target is a few tens of meters from its true location, just enough to make any incoming fire miss.

A ship's Avoidance rating starts the game at its base level (noted on the datacard). Moving, firing weapons, or sending many comm transmissions lowers the ship's Avoidance, while minimizing the preceding activities, or diverting more power to the decoy systems, increases the ship's Avoidance. Keep track of these changes by turning the counter wheel so that the current Avoidance value is pointing to the ship's front.

As with combat between standard units, a ship's defense rolls are modified by its current Avoidance value. It is thus important for Players to keep their ship's Avoidance as high as possible, until an opponent makes a mistake and lowers his own Avoidance enough for a full assault to be launched. The Avoidance counter's position should be updated immediately after any of these events occur:

Cover: every time a ship enters a dust cloud, debris field or other cover, it gets +1 to its Avoidance. In the End Phase, every ship that is hidden from all enemies by an obstacle or ship or is still in a dust cloud, debris field or other cover gets +1 to its Avoidance (see page 43).

Ping: each Ping attempt lowers the ship's Avoidance by -1. If a ship is the target of a successful ping, it gets -2 to its Avoidance (see page 20).

Spoof: every successful spoof attempt adds the Margin of Success to the ship's Avoidance (see page 20).

Tagging: if a ship is tagged by an enemy unit, it gets -1 to its Avoidance (see page 72).

Thrust: -1 Avoidance if thrust is used in the First Ship Phase. An additional -1 is applied if the ship also uses thrust in the Second Ship Phase (see page 19).

Weapons: -1 Avoidance for each shot from any weapon (unless it is Stealthy, see page 65).

No matter what, a ship's Avoidance may never go above the Base Avoidance listed on its datacard. There's only so much a two-hundred-meter hunk of fusion-powered metal can do to hide itself! On the other hand, a ship's Avoidance may never drop below -5 either.

FIRE ARCS ▼

All units have **Fire Arcs** listed in their attack characteristics. These arcs define what portion of a unit's surroundings that unit's weapons may target and affect. The primary arcs are described:

Forward: this arc covers a one-hundred-eighty degree arc centered to the unit's front (see diagram).

Fixed Forward: this allows attacks only within a 90-degree arc centered on the unit's front facing (see diagram below).

Right/Left: similar to Forward, this arc covers a one-hundred-eighty degree arc centered to the unit's right or left side.

Rear/Aft: similar to Forward, this arc covers a one-hundred-eighty degree arc centered to the unit's rear. Aft is synonymous with Rear; it is a nautical term used on warships.

Spinal: a weapon with a Spinal arc may only fire at targets directly in front of the unit in a 1-cm wide path.

Turret: the attack may be used in any direction, regardless of the unit's facing.

Defense Arcs are similar to fire arcs, but they are largely simplified. There are only two arcs, Front and Rear. For standard units, each arc is a one-hundred-eighty-degree semicircle, covering the front half and rear half, respectively, of the unit. Attacks that originate from the unit's front use its Front defense stats, while attacks from the rear use the Rear defense stats. Ships have a rear arc of only ninety-degrees, representing the zone in which sensor readings and spoofing effects are fouled by the presence of the ship's drives.

E-4-2

COMBAT ARC DIAGRAMS ①

ATTACK ARCS

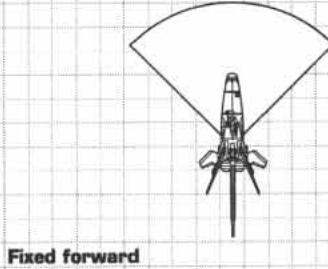
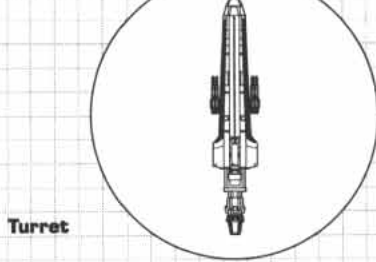

Forward

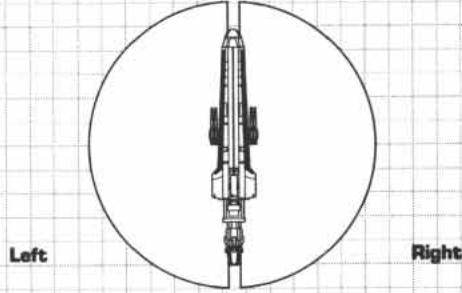
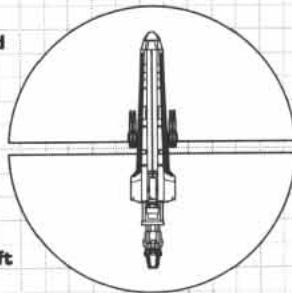

DEFENSE ARCS

Front

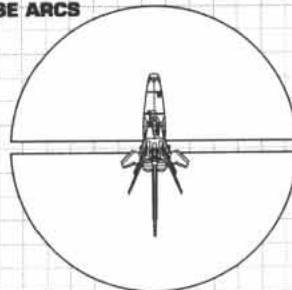

Front

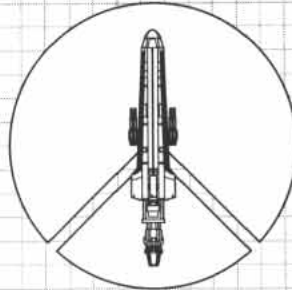



▼ ATTACKING

Attacks are resolved with opposed rolls based on the involved units' Skill Levels. All pilots in the basic game are Skill Level 2, and so will roll two dice for attack and defense. For each Action spent, a unit may use one weapon in an attack against one target, provided that the target is within range, arc and line-of-sight.

On each standard unit's datacard is an area labeled 'Attack,' with several lines of information. Each line corresponds to one weapon that is available to the unit; for each Action spent to attack a target, the unit may choose one of those weapons to use. The only way to attack with more than one type of weapon in a single turn is by expending more Actions. Since most standard units have only one Action, they will only be able to choose one weapon each turn.

Some units may be equipped with additional weapons purchased before the game with Threat Value points. The abilities of these weapons are summarized on page 70, and can also be penciled onto unit datacards. These additional weapons are treated just like built-in weapons; they do not confer extra Actions.

◇ ATTACKING WITH SHIPS

A ship's available attacks are listed in its Components section. A ship attacks with its weapons by using a Fire Weapons Action. Unlike a standard unit's attack, a ship that takes a Fire Weapons Action may fire any or all of its weapons once, not just one of them.

The Player must decide which weapons will fire at what target before actually making any attack rolls. Once the Player finishes declaring his attacks for the ship, he then makes his attack rolls in any order he chooses. He may not, however, change his chosen targets. For instance, if a Player declares that his Poseidon will fire both of its particle cannons at a Pathfinder, and the first particle cannon shot destroys the Pathfinder, the second particle cannon shot simply fires into empty space; it may not be redirected. Thus, Players should exercise judgment in deciding how many attacks to assign to a single target.

Range, Fire Arcs, Accuracy and Damage are worked out just as with standard unit attacks (remember to measure range from the ship's centerpoint). For each Fire Weapons Action, the ship may attack once with as many weapons as it desires, attacking as many targets as it desires.

◇ ATTACKS AGAINST SHIPS

Ships, being rather large constructions, are generally not fired on as a whole. Rather, individual components are targeted and destroyed, often rendering the vessel unable to fight while still leaving it relatively intact. A common tactic is to use exo-armors or fighters to destroy a warship's poorly-armored weapons and drives, leaving its exceptionally well-armored main hull helpless in space.

Ships are so big that it is possible to hit any component by simply moving to the side a bit. As a result, any component on a ship may be targeted and hit from any direction.

At long range, attacks against ships will hit a random component, determined by the table on page 36. Below this range, a unit may choose a component to attack; if the attack succeeds, that component is hit automatically (each system on the Main Hull Damage Table is considered a single component). Warship-launched missile swarms always hit a random location, no matter where they were launched from.

The range at which a unit may choose individual components is determined by the firing unit's Electronics rating. Note that in some cases (like the Pathfinder), a unit's weapons will have a shorter range than its range for targeting ship components.

A ship or standard unit may target individual ship components from any distance beyond the one defined by its Electronics rating, at the cost of a -2 modifier to its attack roll.

▣ TARGETING RANGE

Electronics Rating	Range	Electronics Rating	Range
-1 and below	5 cm	+2	30 cm
0	15 cm	+3	40 cm
+1	20 cm		

CLOSE COMBAT ◊

When two or more units are in base-to-base contact, they are considered to be in close combat. If one of the units is smaller than the other, it may hide behind the larger unit; LOS cannot be drawn to the hiding unit if the larger unit is between the smaller unit and the unit attempting to draw LOS. If the units are the same Size, then any ranged attack on one of those units has a chance of accidentally hitting the other; roll randomly to see which unit is attacked, and then make the attack-defense roll as normal. A unit that is in close combat with several other units may choose which of the other units with which it is in base-to-base contact it will attack, with no chance of striking the wrong target.

The only way most ships can attack a unit in close combat with them is with their PDS (see page 65) while it is in Shield mode, and even then only when the target unit is actually moving into or out of physical contact. A ship cannot move itself to enter close combat; the only way for a ship to actively touch another unit is to ram it (see page 45).

THE ATTACK ROLL ◊

After establishing that LOS exists, determining the range to the target and deciding on which attack to use, one must announce the intention to attack the other Player, and with what type of attack. At this point, both Players will figure out the dice rolls each must make to resolve the attack. Each Player rolls two dice, and modifies the result of the roll with applicable modifiers.

Accuracy: the weapon's Accuracy at the target's range is a modifier that is applied directly to the attack roll.

Overthrust: an exo-armor or exo-suit squad that uses Overthrust movement is subject to an automatic -3 modifier to their attack roll. Fighters are not penalized in this fashion when using Overthrust movement.

Evasion: a Unit that is evading gains a +3 bonus to all of its defense rolls.

Avoidance: the target unit's Avoidance value for the arc from which the attack is originating is a modifier that is applied directly to the target's defense roll. Thus, if the attacker is in the target's Front arc, the defender's Front Avoidance value is added to (or subtracted from) the target's die roll. A ship's Avoidance value is the current number noted on the Avoidance wheel; if the attack comes from inside the ship's Rear arc, an additional modifier applies based on the ship's Rear Base Avoidance.

If the attacker's roll is higher, the attack is a hit, and Damage is scored. If the target's roll ties the attacker's roll or is higher, the attack misses. Note: although there are few instances when one should want to do so, any unit may choose not to defend against an incoming attack, and take zero as its defense roll.

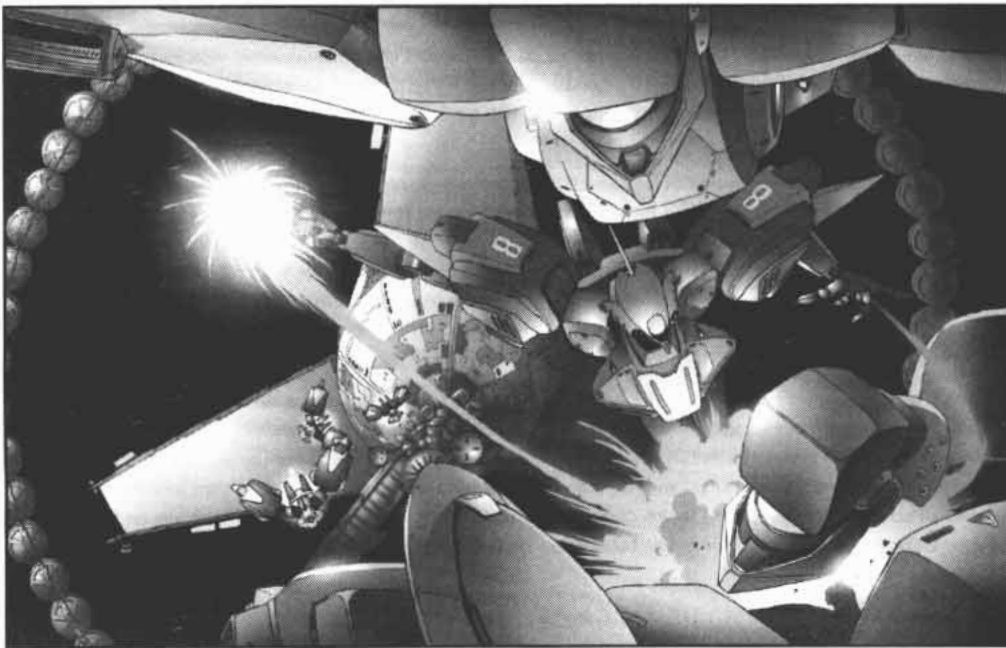



ATTACK ROLL SUMMARY

The attacker's roll equals the roll of two dice modified by:	
•	+ Attack's Accuracy
•	-3 if attacker has Overthrust counter
•	+ Close Combat Optimized bonus (if applicable; see page 62)
•	+ combination bonus (if applicable, see 2.6.5.6)
The target's roll equals the roll of two dice modified by:	
•	+ Avoidance

STANDARD UNIT ATTACK EXAMPLE

A Pathfinder finds itself in combat with a Syreen exo-armor. The Pathfinder pilots maneuver his vehicle near the enemy machine and opens fire. The range between the center of the two machines is 22 centimeters — far, but within maximum range. Since the Pathfinder's pilot has a Skill level of 2, the Player rolls two dice for his attack. He rolls a 3 and a 2; the roll is thus 3. He adds the weapon's Accuracy at 22 centimeters (+0); none of the other modifiers are applicable. The final attack roll is thus 3. The Syreen's pilot also has a Skill level of 2, and rolls two dice for his defense. They come up 4 and 2. The attack is coming from the Front arc, and the Player adds the Syreen's Front Avoidance (+0). The final roll is 4, which beats the Pathfinder's. The attack misses. It's the Syreen's Activation now: it Overthrusts by 20 centimeters, moving into close range with the Pathfinder. The dice come up 6 and 3; modifiers are -3 for Overthrust, +1 for Accuracy at 'C' range. The final roll is thus 5. The Pathfinder's pilot rolls his defense: 1 and 1 — a Fumble! His defense is thus zero, and a world of hurt awaits him...

SHIP ATTACK EXAMPLE

A Poseidon Battleship is at the beginning of its Activation. The controlling Player spends an Action and select Fire Weapons to attack a nearby Valiant strike carrier. Since a Fire Weapons Action allows a ship to fire any or all its weapons, the Poseidon declares that it will fire both its Kinetic Kill Cannons (KKC) and Particle Cannon batteries at the Jovian ship. These weapons have the Rapid Fire characteristic at Rating 1, meaning that each one gets to fire twice. The Poseidon ends up making four separate attack rolls, two for the KKCs and two for the Particle Cannon.

Each shot from the Particle Cannon reduces the Poseidon's Avoidance by 1, for a total of 2. The KKCs (because they have the Stealthy characteristic) do not lower the ship's Avoidance. The range between the center of the two ships is within maximum range of all attacks. Since the Poseidon's crew has a Skill level of 2, the Player rolls two dice for each of his attacks. He rolls a 4 and a 1 for the first KKC; the roll is thus 4. He adds the weapon's Accuracy (+1); none of the other modifiers are applicable. The final attack roll is thus 5. The Valiant's crew also has a Skill level of 2, and rolls two dice for defense. They come up 6 and 3. The attack is coming from the Front arc and the Player adds the ship's current Front Avoidance (-1), for a total of 5. The attack misses. The other three attacks proceed in the same fashion, each being completed before moving to the next one.

COMBINING ATTACKS

Two or more units in the same Group may choose to coordinate, or combine, their attacks against a single enemy, increasing their chances to hit. This can be accomplished through extensive group training or, more commonly, through linked battle computers picking the optimum moment to unleash the attacks so as to catch the opponent off guard.

To combine attacks, a Player must declare which units are going to combine their attacks when the Group is activated. The entire Group does not have to combine attacks; it is perfectly acceptable for two units in a four-unit Group to combine their attacks, leaving the rest of the Group to attack individually. However, all units that wish to combine attacks must take their Actions one after the other, with no interruptions by other units in the Group that are not part of the combination attack. A cumulative +1 bonus is added to the attack roll of each unit in the combination past the first. Units may not combine attacks with units that are not in their Group.

Ships that are in a Group may also combine attacks. Although ships (and some standard units) have multiple attacks, the maximum bonus increment from each ship in a Group is +1. However, the bonus is applied to every target the ship attacks in its turn. It is a good idea, when dealing with combination attacks from large groups of ships, to mark each target with a scrap of paper for each ship in the Group that has attacked it; the number of scraps on a given unit is the current combination bonus the Group has built up on that target. When the Group is done activating, the scraps can be removed.

COMBINATION ATTACK EXAMPLE 1

Five Pathfinders are a Group. When the Group is activated, the Player decides that three of the Pathfinders will combine their attacks against a single Wyvern. Pathfinders B, C and D are chosen as the participating units. The Player begins his turn.

Pathfinder A takes its Actions, unaffected in any way by the combination attack. Then, Pathfinder B acts, attacking normally and thus starting the combination chain. Pathfinder C must act immediately after Pathfinder B, and does so, adding a +1 modifier to its attack roll. Immediately after, Pathfinder D must act, and receives a +2 modifier to its attack roll. This ends the combination attack, and Pathfinder E takes its Actions normally, with no modifiers to its attack roll from the combination attack. If Pathfinder E had been part of the combination attack, though, its attack roll would gain a +3 modifier, putting the Wyvern in a distinctly uncomfortable situation.

COMBINATION ATTACK EXAMPLE 2

Three CEGA Bricriu corvettes are in a Group. When their Activation comes around, there are three Pathfinders (named A, B and C) in range of the ships. The first Bricriu announces that it will spend one action and fire one laser shot each at Pathfinders A and B. It does so, missing both times.

The second Bricriu spends one action to fire, but fires both its beam cannon and its lasers; one shot from each weapon to Pathfinders B and C, so that each of the two Pathfinders is attacked twice. The second Bricriu receives a +1 bonus to hit Pathfinder B, because of the combination bonus from the first Bricriu's attack, but gets no bonus to attack Pathfinder C because the first Bricriu did not fire at Pathfinder C. The second Bricriu fires, and misses all four shots.

The third Bricriu spends one action to fire, and fires one laser shot each at Pathfinders A and C, and one beam cannon shot at Pathfinder C, so that each Pathfinder is attacked once. The third Bricriu receives:

- 1) a +1 to hit Pathfinder A (because the first Bricriu attacked it once, for a +1 combination bonus)
- 2) a +2 to hit Pathfinder B (because the first Bricriu attacked it once, for a +1 combination bonus, and the second Bricriu attacked it twice, for another +1; remember, no matter how many times a single ship attacks a target, the maximum bonus to a single target from a single ship is +1)
- 3) and a +1 to hit Pathfinder C (because the second Bricriu attacked it twice, for +1 combination bonus)

COMBINATION ATTACK EXAMPLE 1

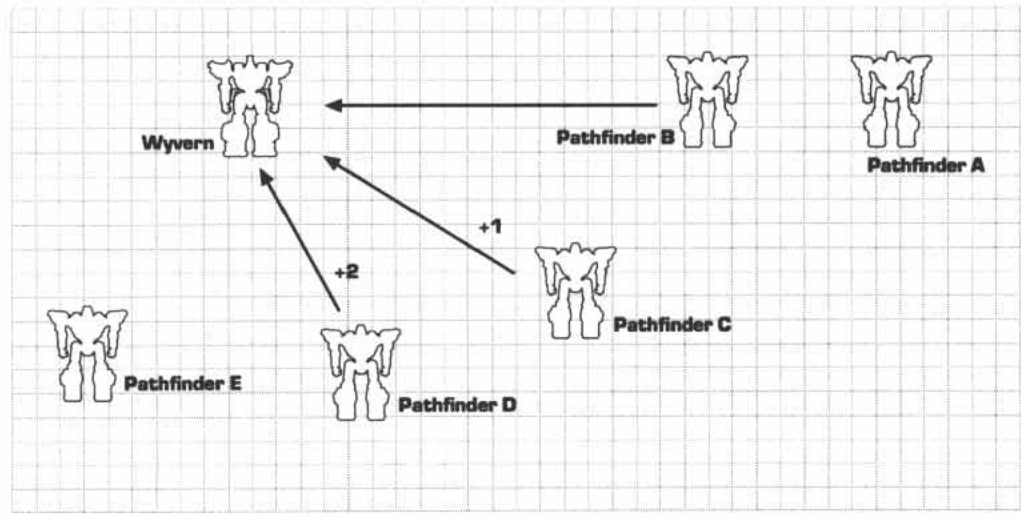



► DAMAGE

After an attack hits a target, a certain amount of damage is inflicted. An attack's damage is equal to the attack's Damage Multiplier times the Margin of Success of the attack roll. The final damage is compared to the target's Protection rating.

There are three values for each defense arc. The first number is the **Stun Threshold**. The second number is the **Crippled Threshold**. The third number is the **Overkill Threshold**. These values are compared to the damage result to determine what happens to the unit being hit.

If the damage is less than or equal to the Stun threshold, the hit was a glancing blow, and no damage is incurred. If the damage is greater than the Stun threshold, the unit is Stunned (sustaining light damage). If the damage is greater than the Crippled threshold, the unit is Crippled (sustaining heavy damage). Finally, if the damage is greater than the Overkill threshold, the unit (or component, in the case of ships) is destroyed outright. Note that, unlike the Silhouette system, a Threshold number must be exceeded, not merely equaled, to have an effect. Thus, a unit that sustains damage equal to the Overkill threshold is only Crippled; the damage must actually exceed the Overkill threshold for an overkill to take place.

Only the most severe of these possible damage results applies to the target. Thus a unit that sustains Crippling damage gains only a Crippled counter. It does not gain a Stunned counter, even though the damage was obviously enough to exceed the Stunned threshold. In short, only one damage result can be inflicted from each hit.

▣ DAMAGE PROCEDURE

Total Damage = Margin of Success x Damage Multiplier
If Total Damage > Stun Threshold, target is Stunned (standard units gain Stunned counter, ships take one point of damage to target component)
If Total Damage > Crippled Threshold, target is Crippled (standard units permanently gain Crippled counter, ships take two points of damage to target component)
If Total Damage > Overkill Threshold, target (or target component) is destroyed

▼ DAMAGE TYPES AND SPECIAL DEFENSES

There are two possible types of damage, designated by letters next to the Damage Multipliers on the datacards. They are:

Energy: these are weapons that do heat or atomic damage by electromagnetic radiation or the impact of various subatomic particles on the target. They are designated by an 'E' on the datacard.

Projectile: these weapons launch some sort of solid mass at the target, inflicting damage by breaking armor and physically tearing through material. Such weapons are designated by a 'P' on the datacard.

Certain units are better protected against one type of damage than another. For instance, the Vindicator has Energy Protection. If the Vindicator is attacked with a weapon that does 'E' damage, it would get a different Protection (listed beside the Energy Protection) if the weapon hit. If the Vindicator is attacked with a 'P' weapon, however, it gets no special defenses, and must use its normal Protection values.

Although there are certainly more types of weapons imaginable (psychic, perhaps, or gravitic), the two types described here are sufficient to cover the Jovian Chronicles universe. Although it is possible for a weapon to have more than one type of attack, such instances do not, for the moment, occur in **Lightning Strike**.

▼ DAMAGE TO STANDARD UNITS



Stunned units are mildly shaken up by the attack, but not seriously damaged. When a unit is Stunned, place a Stun counter on the unit's base. To remove the Stun counter, the unit must spend one Action. If, at any time, a unit has two Stunned counters on it, both counters are immediately removed and replaced with a single Crippled counter. A Crippled unit may be Stunned again by additional attacks or effects, but this time, if there ever are two Stun counters on the unit, the unit will receive a second Crippled counter, and is immediately Overkilled. This effect may be modified by certain vehicle characteristics. Note that a Stunned unit is *not* required to remove the Stun counter if it does not want to. The Stun counter has no adverse effects, and a Stunned unit may operate at full power; the only danger is that if the unit gets Stunned again, it will become Crippled.

► DAMAGE TO STANDARD UNITS

Crippled units are permanently affected. They follow the **'Rule of Halves:'** values for MP allowance and weapon damage are all halved, rounding up. A Crippled counter may not be removed from a unit; it stays until the unit is dead (or repaired after the battle). This effect may be modified by certain vehicle characteristics, like Exposed Fire Control (see page 60).



If a unit ever has two Crippled counters on it, it is immediately Overkilled. Overkilled units are immediately eliminated from the game and should be removed from the board.

STANDARD UNIT DAMAGE EXAMPLE 1 ⓘ

If a Pathfinder attacking a Wyvern with its particle cannon at a range of five cm beats the Wyvern's roll by five, the Margin of Success of the roll would be five. The particle cannon's Damage Multiplier at five cm is 3, which means that the total damage done to the Wyvern is $5 \times 3 = 15$ points. This is greater than the Wyvern's heavy protection rating of 12, but under its Overkill protection rating of 18, so the Wyvern is Crippled.

If the Margin of Success had been 3, the damage total would have been $3 \times 3 = 9$, which would be a Stunned result.

STANDARD UNIT DAMAGE EXAMPLE 2 ⓘ

A Pathfinder has scored a successful hit on an enemy Syreen. The Margin of Success of the attack — that is, the difference between the attacker and the defender's die rolls — is multiplied by the Damage of the attack at the range between the two Units. In this case, they are separated by 22 centimeters, which indicates we should use the right-most entry (Damage 2 E). The Pathfinder's Player rolled a 6, the Syreen's a 2. The damage is thus $(6-2) \times 2 E$, or 8 E. This is compared to the Syreen's Protection, which is 3/6/11; the Syreen has no special defense versus 'E' attacks. 8 is higher than 6, but lower than 11. The Syreen then receives a Crippled counter. It now moves at 6/12 and halves the Damage Multipliers of all its weapons.

DAMAGE TO SHIPS ▼

Ships, being much larger than standard units, are not attacked as a whole, but rather as individual parts of a whole. When a ship is hit by any attack not aimed at a specific location, a hit location must be determined. Roll one die and consult the Basic Hit Location table below, then check either the Main Hull Location Chart or the Component Location Chart, depending on which result was rolled.

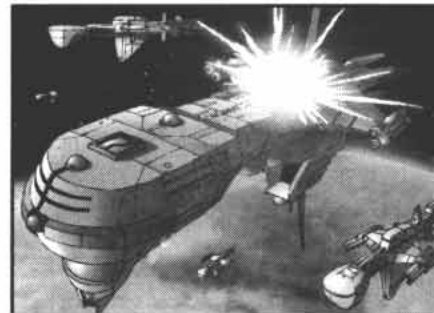

If the Basic Chart indicates a hit to the Main Hull, roll one die to find out which system in the Main Hull has been hit. If a roll results in a hit on a system that is already Overkilled, the attacking Player may choose a different system from this table.

If the Basic Chart indicates a hit to a component, roll one die and check the numbers along the left side of the target's datacard to see which component was hit. For example, a long-range shot hits a Valiant carrier. A 5 is rolled on the Basic Hit Location Chart, which means a component was hit. One die is rolled. It comes up 3. Looking on the left side of the Valiant's datacard, we see that a roll of 3 means that the Spinal Laser, with a Protection of 15/30/45, was hit. If a roll results in a hit on a component that is already Overkilled, the attacking Player may choose a different component on the ship's datacard.

Some vessels (like the Venusian Shan-Yu) have more than six components listed on their data cards. When the attacker rolls for a random component hit, and gets a location that has two or more components, all the components with that hit location number are affected by the hit. If an attacker is choosing a component to attack, and chooses a component that has the same hit location number as one or more other components, then his attack will affect all the components with that hit location number.

If the attacker chose a specific component to attack, he may choose any single system or component from either the Main Hull Damage Table or the Component Damage Table.

2.5.3



◇ HIT LOCATIONS

Ships are rather difficult to effectively Cripple. Hits that would obliterate an exo-armor can, on a ship, be either repaired or backed-up with little effort. Only very severe damage or repeated hits on a single system are likely to damage a ship beyond the ability of its damage control crews to repair. To reflect this, and to help Players keep track of the fact that ship systems can be damaged and repaired repeatedly, each system on a ship's datacard has two small checkboxes next to it. These damage boxes can be marked off (with a pencil or other erasable marker) as the ship's systems take battle damage. Successful Damage Control rolls allow marked-off damage boxes to be erased (see page 20).

If the hit exceeds the Main Hull or Component's Stun Threshold, mark off one damage box on the appropriate section of the ship's datacard. If the hit exceeds the Main Hull or Component's Crippled Threshold, mark off two damage boxes in the appropriate section of the ship's datacard.

If the hit exceeds the Component's Overkill Threshold, or if you need to mark off a damage box and there are no more empty damage boxes in that section, cross the entire relevant section out. It is Overkilled (destroyed) and may not be repaired during the battle.

If any single Main Hull hit inflicts enough damage to exceed the Main Hull's Overkill Threshold, the entire ship is immediately destroyed. Leave the miniature on the table; it may explode in the End Phase (see next page), but if it does not, the drifting hulk can be used as cover by other units.

Note that the only difference between Stun damage and Crippling damage to a ship is the number of damage boxes that are crossed off. When a ship system is damaged, regardless of the severity, it is turned to "standby" mode for ease of repair. So, as long as the system isn't Overkilled (and completely destroyed), any damage result will have the same effect. However, if a system with no empty damage boxes takes another hit, it will be Overkilled, so it's important to repair heavily damaged systems (i.e. those with both damage boxes marked off) as quickly as possible!

▣ BASIC HIT LOCATION CHART

1-4	Main Hull; roll on Main Hull Damage Table
5-6	Component; roll one die and find result on target's datacard

▣ MAIN HULL DAMAGE TABLE

Die Roll	System	Stun/Crippling Damage	Overkill Damage
1	Damage Control	Damage Control rating is halved, rounding up, damage is completely repaired.	Damage Control destroyed. No further damage until the control rolls may be made.
2	Reactor/Power	Number of Actions is halved, rounding up, until the damage is completely repaired.	Number of Actions drops to 1. Every End Phase, roll for Catastrophic Damage
3	Command and Control	Crew Level halved, rounding up, until the damage is completely repaired (i.e. replacement crew arrives at battlestations).	Crew Level drops to 1, any Skill Bonus is lost.
4	Electronics	Electronics Rating drops to -2 until damage is completely repaired.	Electronics is -2 permanently. All spoof attempts roll half the normal dice (round down).
5	Structure	Turning Type drops one level until the damage is completely repaired.	Whenever ship changes facing, roll one die. On a 4, 5, or 6, the ship breaks apart and is destroyed.
6	Radiation Shielding	Base Avoidance reduced by 2 per damage box until repaired.	Base Avoidance reduced to -3, permanently.

▣ COMPONENT DAMAGE TABLE

Component	Stun/Crippling Damage	Overkill Damage
Drives	The ship's Thrust value is halved	The ship may no longer apply thrust, nor may it change facing.
Hanger	The hanger is out of commission until it is completely repaired. All units inside the hanger are Crippled.	The hanger is destroyed, and may no longer launch, repair or recover units. All units inside the hanger are destroyed.
Cargo	20 points of cargo are destroyed (attacker chooses) for each damage box marked off. No repairs are possible.	All cargo is destroyed.
Weapon	The weapon is taken off-line for repair. It may not fire until completely repaired.	The weapon is destroyed and may not be repaired.
PDS	The PDS system's Damage Multiplier is halved (round up) until it is completely repaired.	The PDS system is destroyed and may not be repaired.

CATASTROPHIC DAMAGE AND EXPLOSIONS ◇

Ships in **Lightning Strike** are powered by one or more large fusion reactors. Although quite stable under normal operating conditions, and engineered with failsafes in case of damage or core breaches, the reactors are nonetheless both delicate and volatile and can, on some occasions, overload, trigger a runaway fusion chain reaction and explode with devastating results.

Whenever a ship's Reactor takes an Overkill hit, the reactor runs the chance of exploding. In each End Phase, roll one die. On a one through five, the reactors' failsafes successfully bleed off and cool down the core, staving off a critical buildup for one more turn. If the roll comes up a six, one of the ship's reactors cannot shut down in time and explodes. Add one to the roll for every other Overkill hit the ship's Main Hull has taken in addition to the Reactor hit.

In cases when a ship's Main Hull is Overkilled as a result of a single shot, the reactor may also explode. The roll in the End Phase is made as normal, but if no explosion occurs, no further rolls need be made; the ship is now a floating hulk drifting in space.

A reactor explosion affects everything within a number of centimeters equal to the ship's Size. Every unit or ship within this radius takes an amount of 'E' damage equal to the ship's Size multiplied by the roll of one die. Affected ships only take damage to components facing the explosion's center. The ship itself, everything in it, and everything that was in close combat with it, are vaporized with absolutely no chance of survival or salvage.

If a ship manages to get off the table, it is considered "safe," and no longer has a chance of exploding; out of the heat of battle, the crew manages to cool the reactor down and safely bring the ship back to port.

SHIP DAMAGE EXAMPLE ▣

A Bricriu-class corvette is on the sharp end of a rather brutal attack that causes 20 points of damage. The attack comes from long range, so a die is rolled to determine the location. The die turns up a 4, meaning a Main Hull hit. 20 is higher than 18 (the Main Hull's Crippled Threshold), so a roll is made on the Main Hull Damage Table (if the shot had exceeded the Main Hull's Overkill Threshold, the whole ship would have been destroyed). The roll comes up a 6, which is a Radiation Shielding hit. Two boxes are marked off the Avoidance section of the datacard, and the ship's Base Avoidance drops by -4 until the damage is repaired. If the Radiation Shielding takes another hit before it's repaired, there will be no more damage boxes to fill in, and the Radiation Shielding will be Overkilled.

Another group of attackers, which is closer, decides to target the ship's engine in an attempt to immobilize it. Their Electronics rating is 0, requiring them to move within 15 cm of the ship to target a specific component. They do so, and attack the Drive component. They Stun the drive section, which causes one damage box to be filled in and the ship's thrust to be cut in half. Another attack comes in and cause Crippling damage to the engine. This would normally fill two boxes, but since one is already marked off, the engine section is Overkilled! In the End Phase, the Player checks for explosion and roll one die: it turns up six. A runaway chain reaction starts up and the fusion drive explodes. One die is rolled for damage: another six, which is multiplied by the ship's Size, 7, to yield 42 points of 'E' damage to anything within seven cm of the doomed vessel. At least they took some of the attackers with them...

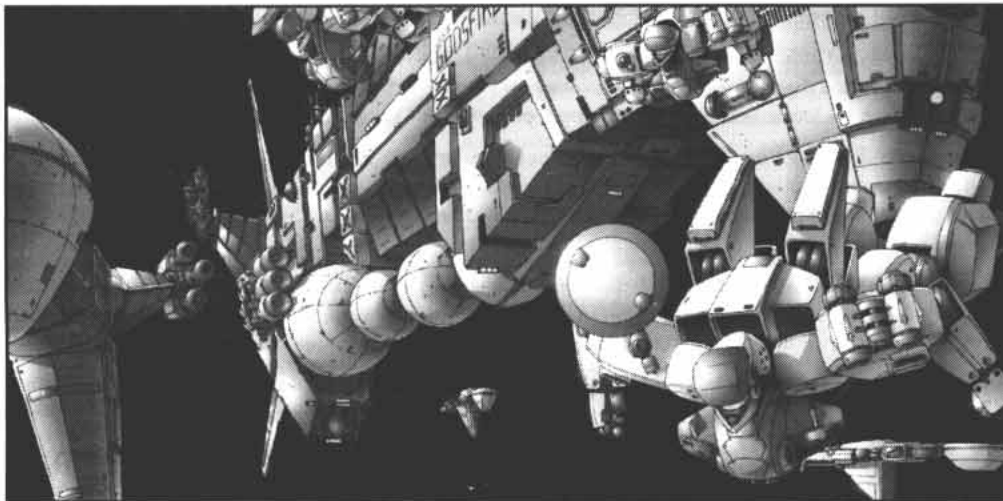



▶ ASSEMBLING THE MINIATURES

The **Jovian Chronicles** miniatures are high-quality multi-part kits that require some assembly to complete. A few tools will be needed; while some may be costly, they will last for many years if cared for properly. You will need glue, a pin vise, drill bits, a hobby knife and wire snips. Some other tools you may want are: pliers, clamps, needle files, sandpaper (multiple grades), tweezers, small scissors and modeling putty.

▼ GLUE

You will need either cyanacrylate (CA) or two-part epoxy glue to assemble the model. CA glue is better known as superglue. It bonds just about anything very strongly, but the bonds formed are weak unless the mating surfaces are clean, absolutely dry and fit well. CA glue is best applied with a small toothpick. The better the fit between the parts to be joined, the stronger the bond. Be extremely careful when working with CA glue: it *will* glue anything that comes into contact with it, including skin! Cyanacrylate contains some very minute quantity of cyanide, which is a toxic compound. Use it in a well-ventilated area and don't breathe the fumes. *Never, ever* heat it to make it cure faster.

The term "epoxy glue" covers a variety of adhesive resins that are cured by a chemical reaction instead of evaporation. Most epoxies come as a two-part set that must be mixed in equal proportions, yielding a strong and nearly universal glue. They require a few minutes to set, making them perfect for assembling variable position parts.

▼ SAFETY FIRST

When talking about tools one must talk about safety. Remember that any tool capable of cutting through plastic and metal is doubly capable of cutting through flesh!

When using a cutting tool, make sure you cut away from yourself to avoid accidents. A dull blade will be harder to control and require more pressure to cut, increasing the chances of slipping and causing injuries, so be sure the blade is very sharp.

Don't forget that many paints and glues are toxic to some degree. Do not breathe the fumes and be sure to work in a well-ventilated area.

When sanding or filing, remember that any small airborne particulates can be carcinogenic. Always use water when sanding or filing to prevent particles from accumulating in the air you're breathing.

Your work area should always be kept tidy, clean, and well-organized. It is vital that it be well lit; the best light source, bar none, is the sun. If a window is not available, make sure that you have plenty of good illumination that is comfortable to your eyes.

▼ BASIC ASSEMBLY

Your miniatures are generally made of metal parts (non-toxic pewter), which requires the use of either CA or epoxy glue for assembly. Start by cleaning all the parts, removing flash and mold lines.

Small parts may be attached to a metal bar called a sprue. Do not twist the parts off the sprues — it is the best way to damage them. Use a hobby knife or a pair of small cutters, and don't cut too close to the pieces; after the pieces are loose, you can clean them up properly with a hobby knife or file.

Once the part is free, remove any flash or mold lines by gently scraping it off with a knife or file, then lightly sand until you are satisfied with the finish. Repeat for each new part, paying special attention to small detail pieces. Assemble the parts without glue to see how they fit together. Cut, file and bend where necessary to improve the fit.

When you're ready, attach the parts with glue. Some parts may be left off for painting to make the job easier. If this is the case, make sure the joint won't be too apparent afterward, since you won't be able to apply putty (see page 33 on the painted surfaces. Spray the model with an undercoat primer before painting it.

A note on assembling ships: the spaceship miniatures are cast in resin, a light and easy-to-work polymer. Resin is easier to cut and drill than pewter, but it is also more fragile. Be extra careful when working with gun turrets and wings. Otherwise, prepare the model for painting just as you would a pewter kit.



JOVIAN FORCES ◀



DP9-401
PATHFINDER



DP9-411
RETALIATOR

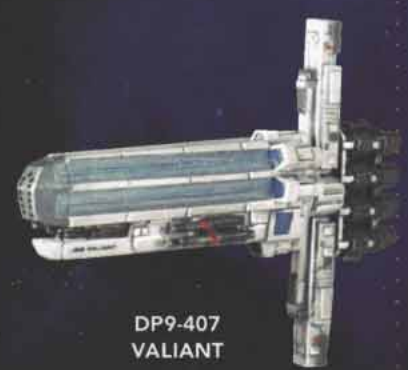

DP9-407
VALIANT



DP9-409
LANCER
(2 per pack)

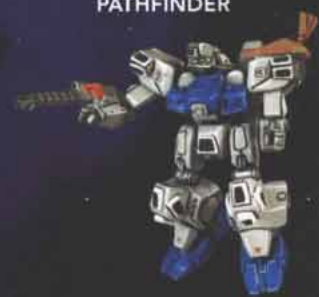

DP9-413
PATHFINDER
SNIPER



DP9-405
VINDICATOR



DP9-403
ATHENA

CEGA FORCES ◀



DP9-406
CERBERUS



DP9-414
WYVERN
MARINE



DP9-408
POSEIDON



DP9-410
WRAITH
(2 per pack)



DP9-412
SYREEN



DP9-402
WYVERN



DP9-404
HACHIMAN

▶ HOW TO PAINT MINIATURES



STEP 1

STEP 1: PAINTING PREPARATION ▼

Once the miniature is cleaned and assembled, attach it securely to its base (or other convenient handle) so you don't have to touch it while painting. Apply a coat of primer to the entire surface — this will allow the paint to stick better to the model, and also allows you to see (and correct) any surface defect before you start painting. Primers are generally sold in spray cans; white or light gray is a good choice.



STEP 1



STEP 2

STEP 2: BASIC COLORS ▼

Once the primer coat is thoroughly dry, apply the basic colors of the paint scheme you have selected to the entire model. Acrylic paints are the best choice, since they are non-toxic, have little odor and can be diluted with water.

Try to keep the divisions between basic colors neat and straight, though at this point any mistakes are easily corrected. Make sure the paint is properly diluted and not too thick: it should cover the surface without obscuring details. Remember that two light coats are always preferable to a single thick coat.



STEP 2



STEP 3

STEP 3: SECONDARY COLORS ▼

Once the basic colors are dry, start painting the other major areas of the models: thruster ports, weapons, missiles, etc. Once more, it's important to keep the colors neat and apply thin coats to avoid obscuring surface details. By now you'll have a good idea of what the finished model will look like. If you are in a hurry to play, models painted up to this step look quite acceptable on the tabletop.



STEP 3



STEP 4

STEP 4: DETAILS AND LINING

Prepare a darker mix of the color of the area you'll be working on, and dilute it so the paint will flow freely. Using a thin brush, apply this mixture to the model's panel lines and joints. This will create deep shadows and generate the illusion that the miniature is a complex mechanical device rather than a solid piece of pewter. The raw metal areas can be accentuated by brushing metallic paint over a black or dark gray coat. Load the brush with pigment but remove most of it on a dry towel before applying it. You want metallic accents, not a solid color (remember, you can always add more if need be).



STEP 4



STEP 5

STEP 5: HIGHLIGHTS AND DECALS ▼

Highlighting accentuates the details. Prepare a lighter mix of the color of the area you'll be working on. Using a thin brush, lightly apply this mixture on raised details and corners — basically, any place that would catch light. This is easy to overdo, so be careful. Once this is done, paint any remaining small details: sensors, antennae, etc. Each miniature comes with a small decal sheet so you don't have to paint the markings on; see page 33 for instructions. Once this is done, paint the base, apply a national insignia to it (optional) and seal the paint job with a clear varnish to protect the model during play.



STEP 5

► HOW TO MAKE ASTEROIDS

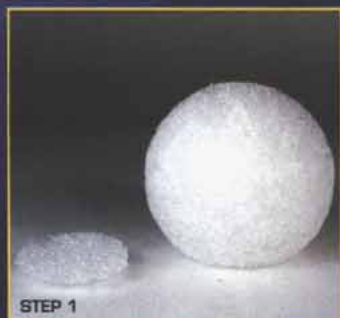

STEP 1

STEPS 1 & 2: PREPARATION ▼

The best material to create asteroids is an ordinary Styrofoam ball, available in most craft stores. You can use real rocks, but foam can be carved into the shapes you want. Real asteroids can have any shape, but the bigger they are, the rounder they tend to be because of their own gravity. Cut some depressions on the surface of the Styrofoam ball to make impact craters and other features. Make a hole in the bottom for the stand, or just sand the base flat.

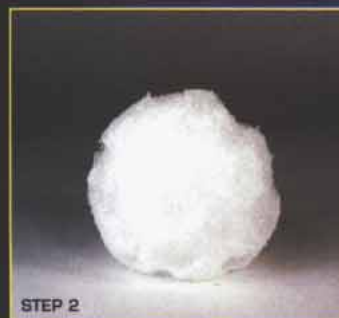

STEP 2



STEP 3

STEPS 3 AND 4: SURFACE ▼

Once you're satisfied with the shape, it's time to cover up the pores in the Styrofoam. Plaster or wallfiller is a good material to work with; it's water-soluble, odorless and you can pre-color it with acrylic paint. Apply a light coat to the surface, being careful to make it even and not too thick (or else it will not dry properly). Once it's fully dry, apply more plaster until you are happy with the shape and texture. Let dry, then paint in gray or brown colors.



STEP 4



STEP 5

STEP 5: DETAILS ▼

Prepare a paint mix slightly lighter than the color of your asteroid. Take an old, wide brush, dip it in the lightner paint and then remove most of the pigment with a paper towel. Lightly run the brush across the surface of the asteroid; the ridges and edges of craters will pick up minute amounts of paint, making them stand out. Repeat until you are happy with the results. Once the asteroid is dry, glue it to its base (if it has one).



STEP 5

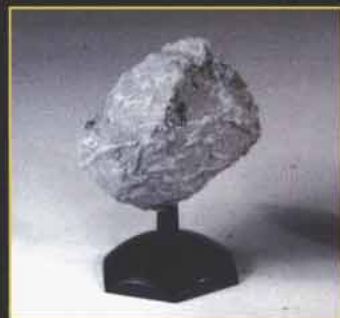

EXAMPLES ▼

The irregular rock on the left has been glued fairly high on its flight stand. The impact crater on the right side has been created by gouging a piece of foam out before applying the plaster. The asteroid on the right received less plaster to give it a pitted, rougher texture. Feel free to experiment with shapes, textures and color — no two asteroids need be the same!



ASTEROID BASES ▼

Find some spare bits of model; in these pictures, we used a chopped-up Poseidon battleship, but any blocky bits will do. Drill a small hole in each piece and glue a piece of wire into the hole. Prepare the asteroid as noted above, but pin the bits in place while the plaster is drying so they will sit correctly on the surface. Once the plaster is dry, remove the pieces carefully, paint the outpost(s) and the asteroid separately, then glue them together.



► MAKING THE TABLETOP



CREATING A STARFIELD ▼

Use a large piece of black fabric (felt is nice) as a base. Iron out the creases and lay it down on some newspapers to protect the surrounding surfaces. Take an old toothbrush and dip it in light-colored acrylic paints, then "flick" the paint off onto the black fabric to create stars. Let the fabric starfield dry thoroughly before using it, roll it up and store it in a dry, clean space between game sessions.



STARFIELD PATTERNS ▼

You can create patterns and nebulas by varying the amount of stars and their colors. Individual stars and other objects can also be painted on directly. The surrounding patterns are just a few of the possible types of starfields you can create to serve as a backdrop to your games. You can find additional ideas in astronomy books and on the Web. But don't let these constrain you — as long as you like the results, all patterns are equally valid!



BATTLE ON! ▼

Though the game can be played on any flat surface, a miniature battle will look so much better on a proper starfield! These are some images of what a Lightning Strike battle looks like with painted miniatures and props. Asteroids provide some cover, and you can make makeshift markers for dust clouds and debris out of cardboard, cotton balls and anything else that comes in handy. Above all, have fun modeling your forces and settings!

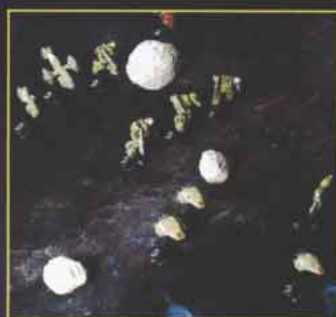
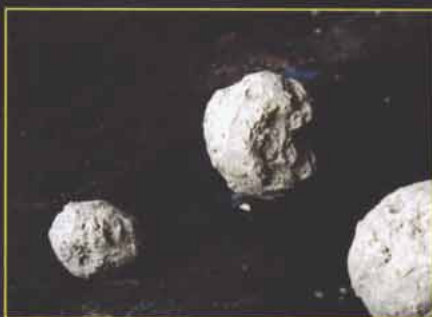

PINNING ▼

Although CA and epoxy glues are strong stuff, gamers are stronger by far. While a simple glue joint is sufficient for display and careful handling, a regularly used gaming miniature will probably require more structural support. Pinning involves drilling a small hole in a part where it joins another part, and inserting a stiff piece of wire (like a pin) into the hole, so that part of the pin protrudes. Then, a matching hole is drilled where the part is supposed to go, allowing the two parts to be joined with the pin acting as a structural reinforcement. Use a longer wire for bigger parts to add more strength.

Although any thin, stiff wire will work, the best pinning wire for the price is a small paper clip. Simply unbend a portion of the clip and use snips to cut off a piece of the desired length. Use an appropriately-sized drill bit to drill the holes. If you lose your pin, there's plenty more where that came from.

FLIGHT STANDS ▼

Most **Jovian Chronicles** miniatures include a two-part black plastic flight stand. A hole for the flight stand will have to be drilled somewhere on the miniature. If you are using the plastic display post included with the miniature, use a 1/16" drill bit. Alternatively, you can use the same kind of wire you use for pinning the miniature; simply drill a hole in the bottom of the plastic hex base and glue the wire in to make a sturdier flight stand suitable for rough use (don't forget how useful paper clips are). You can place the flight stand hole anywhere you like; although the most common method is to place the hole between the legs of exo-armors or under the hull of ships for stability, there's no reason why you can't drill the flight stand hole elsewhere, to depict a miniature on its side, flying on its back, or even upside down!

PUTTY AND GAP-FILLING ▼

Gaps may appear where the parts meet. Putty is a malleable substance that hardens when it dries. Putty comes in small, squeezable tubes, and several brands are available at your local hobby or game store. Apply the putty with a toothpick — just enough to fill the gap — and let it dry before sanding off the excess. Model putty takes forever to dry when applied in thick coats. If the gap to be filled is in a detail-dense area of the model, apply strips of masking tape on either sides of the gap to prevent the putty from filling in the detail. Remove the tape once sanding is done.

The structural strength of regular model putty is somewhat poor. If you have to build up a large area, two-part epoxy putty is a better choice. Epoxy putty consists of two bars of different colors that must be mixed in equal proportions. You can work the putty with sculpting tools, blending it into the model instead of sanding it away. The putty will adhere to almost any surface, so work it with damp tools. Always wash your hands and your tools immediately afterwards.

DECALS AND MARKINGS ▼

Jovian Chronicles miniatures include decal sheets with numbers and national insignia on them. For extra personality and flashiness, you can also find a huge variety of small-scale decals at many hobby and game shops. Warning tags, nose art and other insignia can really enhance your fleet's appearance, and with decals, you won't have to be a master painter to get things to look good.

Each marking should be cut out from the sheet as close as you can without damaging it; this will help hide the carrier film. The model's surface must be clean and dry. Dip each marking in water for a second or two; don't put them all in at the same time, because the glue will dissolve to nothing before you have the chance to place them all. Let the wet decal stand for a few seconds. Using tweezers, place the damp decal over its intended spot. Carefully slide it into place — don't try to lift it from the backing sheet, you'll rip it apart. Once you are satisfied with the decal's position, use a dry cloth to gently absorb the excess water. Don't rub, just tap, or you will rip and otherwise damage the decal film. Apply clear varnish to protect it once it's dry.

KITBASHING ▼

Entire books and Web sites have been devoted to this subject, which encompasses more tricks and techniques than we could ever cover in one rapidly diminishing paragraph. Simple conversions can be accomplished by cutting and pinning arms, legs and waists to different poses, or using bits of spare sprue or plastic to create modified weapons and equipment. For inspiration and ideas, see the Dream Pod 9 page (<http://www.dp9.com>) for modeling links; the site will also feature modeling articles in the future.



▶ EXPANDED ACTIVATION OPTIONS

3.1.1

The following three options give standard units more flexibility in battle, allowing them to adjust their offensive and defensive stances according to the current tactical needs. Evading makes a unit stronger defensively at the cost of its offensive capabilities; Aiming makes a unit stronger offensively at the cost of some defensive capabilities; and Reaction Attacks let one reacts immediately to new and unexpected threats. These options can be used only by standard units, and do not apply to spaceships.

▼ EVADING

3.1.1.1



Exo-armors and exo-suits, with their spectacular maneuverability, are very good at being slippery targets. At the beginning of its phase, an exo-unit may choose to forgo all of its Actions for the turn in order to perform a series of violent evasive maneuvers. Place an **Evasion** counter on the unit; this counter remains in effect until the unit's next activation. An evading exo-unit gets a +3 modifier to all its Defense Rolls until its next phase. An exo-unit may not both evade and Overthrust.

Fighters are not quite as good at evading as exo-armors are. If a fighter chooses to give up all its Actions in order to evade, it must move a minimum distance equal to its normal Movement allowance. This represents the fact that most of a fighter's evasion bonus will come from minor jinks in the course of fast movement in one direction, rather than the somersaults and twists an exo-armor is capable of. A fighter may evade under both normal and Overthrust movement, and gains +3 to all Defense Rolls until its next phase. Mark evading fighters with Evasion counters.

An Evading unit move, but it may not attack, counterattack or spend actions in any way; even using a Command Point (see page 39) does not allow an evading unit to take an action.

▼ AIMING

3.1.2



A unit may intentionally fly a stable, straight path, or perhaps turn on a bright searchlight or laser sight, in order to increase its chances of hitting a target. This is referred to in the game as **Aiming**. The use of Aiming must be declared when the unit begins its activation. Place an Aiming counter next to the unit; this counter remains in effect until the start of the unit's next activation in the next turn. While the Aiming counter is active, the unit gains a +1 modifier to all its attacks, as well as a -1 penalty to all its Defense Rolls. Any standard unit may aim, but remember that Evading units cannot attack, and Overthrusting exo-units have a -3 penalty to their attacks.

▼ REACTION ATTACKS

3.1.3

Normally, a unit may only attack during its activation. The addition of the **Reaction Attack** rule allows a unit to attack outside of its activation. In a game in which Reaction Attacking is allowed, any standard unit (not ships; they're too slow to react) may take a single Action anytime in the First Ship Phase, Main Phase or Second Ship Phase. The Action can be used for anything that normally requires an Action (note that standard unit movement is *not* an Action); this is most often an attack, but the Action may also be used in other ways (see *Options and Add-ons*, page 70).

A Reaction Attack works just like a normal attack, and operates under all normal restrictions for fire arc and movement mode (i.e. Overthrusting exo-units have a -3 to their Action, and Evading units may not Reaction Attack). However, unlike normal attacks, which cost one Action in the unit's activation, using a Reaction Attack results in a Stun counter being placed on the Reaction-Attacking unit. Otherwise, there is no cost for using a Reaction Attack. The placing of the Stun counter is to simulate the unit's pilot being flustered by an incoming unit and using his attention to fire off a quick shot at his attacker, and not paying attention to the status of his machine.

A unit may Reaction-Attack as many times as it likes, taking a Stun counter each time it does so. However, there is a practical limit on the number of times a unit may Reaction Attack. If it Reaction Attacks twice in quick succession, it will have two Stun counters, and is immediately Crippled. A Crippled unit may Reaction Attack, but only if doing so would not result in its destruction (i.e. a unit that is both Crippled and Stunned may not Reaction Attack, since doing so would give it another Stun counter, destroying it). Thus, Reaction Attacks are something of a tradeoff; they allow units to fire on incoming threats, but make any further incoming attacks that much deadlier.

SHIP VECTOR MOVEMENT ◀

Normally, once a ship finishes its movement, it sits still until the next time it gets a chance to apply thrust. This movement implies that the ship is carefully watching its velocity and burning retro-rockets if needed to keep itself on course.



3.2

It is possible, however, for a ship to allow itself to drift a certain amount each turn, independent of any other thrust it may apply. Anytime a ship expends its full movement allowance to move straight ahead, it may be given a **Vector** counter. The vector counter has an arrow on it; place the counter next to the ship so that the arrow points in the direction of the ship's movement. This counter moves with the ship, but its direction does not change; it will always point in the direction it was first placed, unless it is actively changed.

In the Initiative Phase, all ships that have vector counters are moved a number of centimeters equal to their normal thrust (or half their normal thrust, if their drives have been damaged) in the direction the vector counter is facing. Note that this movement is independent of the ship's current facing, so it is possible for the ship to be moved sideways, or even "backward." This movement costs no movement allowance, does not alter the ship's Avoidance, and is mandatory for all ships that have vector counters.

Note the difference between using movement allowance to thrust and simply drifting as the result of having a vector counter. Thrust involves activating the ship's engines and applying backward force, altering the ship's Avoidance value and allowing the ship to turn. Vector counters simulate the fact that in space, anything that's given a push in a direction will keep on moving in that direction forever, until something stops it. Movement due to a vector counter does not alter a ship's Avoidance, and never involves facing changes of any sort.

After the vector counter movement is resolved, the ship may still apply thrust as normal in the rest of the turn, but the vector counter will remain facing in the same direction, regardless of any movement or facing changes the ship makes.

The vector counter's direction may be altered, under certain conditions, if the Player so chooses. Anytime the ship expends its full movement allowance to travel straight forward, the vector counter's direction may be shifted from its original facing to the ship's new direction of travel. If the Player decides not to change the vector counter's direction, the vector counter will remain as is, and the ship will continue to drift in its old direction every turn.

To remove a vector counter completely, a ship must spend its entire movement allowance applying thrust in the direction opposite from the vector. The ship must be facing within forty-five degrees of the direction opposite the vector counter's direction. Obviously, the ship may not make any turns, since it must use its entire movement allowance to remove the vector counter. The ship doesn't actually go anywhere; the only result of this expenditure of movement allowance is the removal of the vector counter.

This movement system allows a ship to move in one direction, spin around and fire at a target behind it, while still moving away. It's not completely realistic, but it does reduce the need to calculate combined vectors. For full 3D vector movement, use the roleplaying/tactical Silhouette system in the **JC Rulebook**.

VECTOR COUNTER EXAMPLE ◉

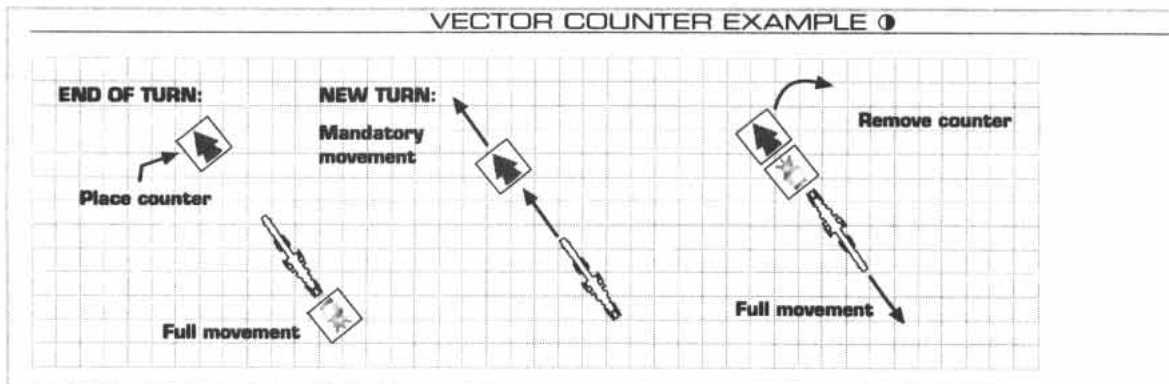



▶ EXPANDED CLOSE COMBAT

In the basic rules, units in physical contact with one another carry out combat normally, with the exception that most units inflict more damage in close combat, and most exo-units get bonuses to hit and defend because of their Close Combat Optimized Perk (see page 62). These rules add a more cinematic aspect to close combat, by allowing units in close combat to attack and defend simultaneously, much as in a real fistfight.

Under these rules, physical contact between counters is the only time when attacks may take place simultaneously. Although the miniatures in **Lightning Strike** are much larger than they would be in "reality," for ease of play, when miniatures (or their bases) come into physical contact with one another, the units they represent are considered to actually be touching, even though their centers would be hundreds of meters apart if properly scaled.

Whenever two counters are in physical contact with each other, they are considered to be in **Close Combat**, shooting at point-blank range and using their limbs to punch and kick. Units in close combat are treated differently in the following ways.

◇ MELEE TARGETS

The two units are so close that other units cannot shoot at one without running a chance of hitting the other. A shot fired into a close combat situation will attack one of the combatants randomly (flip a coin, or roll a die to determine which). After the target has been determined, attack and Defense Rolls are made as normal; the attacking vehicle may not cancel its shot if it finds out that it is about to shoot a teammate!

◇ COUNTERATTACKS

A unit that attacks another unit in close combat will likely do more damage, but also runs the risk of being damaged or destroyed by a swift counterattack. Every close combat attack consists of two attack rolls and two Defense Rolls, one from each combatant. In other words, when two units are in close combat, both of them get to attack and defend. The defender's attack is basically a free Action, and does not restrict it from using its normal Action later in the turn. This "free attack" is simply part of the close combat sequence, representing the throwing of a quick counter-punch while dodging an attack. This means that it is possible for both combatants to be destroyed in a close combat.

If both combatants survive a close combat exchange, they remain locked in close combat until one of the combatants decides to move away.

◇ MULTIPLE ATTACKERS

When a single unit is attacked by multiple close combat opponents in a single turn, it may fight each and every attacker normally. However, the presence of multiple attackers is a significant distraction to a vehicle's pilot. Every enemy in physical contact after the first modifies the defender's combat rolls by -1. For example, a Pathfinder is attacked in close combat by a Syreen, and both units survive the exchange. Before the Pathfinder can move away, however, another Syreen moves into close combat. Another close combat exchange takes place, but this time, the Pathfinder gets a -1 penalty to both its defense and attack rolls. If a third Syreen were to close assault the Pathfinder before it could get clear, the Pathfinder's rolls would then be modified by -2. If, on the other hand, the Pathfinder were to move away from its other two attackers before being attacked by the third Syreen, it would be able to fight at full strength, because only one enemy would be in physical contact with it.

● CLOSE COMBAT EXAMPLE

A Pathfinder moves into base-to-base contact with a Wyvern that has not yet moved. The two units are now in close combat. The Pathfinder's Action is to attack the Wyvern with its particle cannon. The attack succeeds, and the Wyvern is destroyed. However, the Wyvern still gets to make its free counterattack, and does so, destroying the Pathfinder. At the end of the Pathfinder's Action phase, both units are destroyed (they probably managed to knock each other's heads off at exactly the same time).

GRAPPLING ▼

The Expanded Close Combat procedure above essentially consists of units making one-off exchanges at point-blank range, rather akin to jousting. Any unit is capable of this kind of melee combat. For units that are Close Combat Optimized (see page 62), however, there is another, more up-close maneuver option, known as **Grapping**. This is a mechanized combination of martial arts and wrestling that involves full use of an exo-vehicle's arms and legs to both inflict damage and avoid being damaged in return. Grapping is useful to keep a normally slippery exo-vehicle in one place, and is especially deadly against fighters and non-Close-Combat-Optimized units. Grapping is also useful because it involves holding on to an enemy and finding weak spots in his armor; Avoidance and Protection ratings are thus irrelevant. Note that using the Grapping rule will put fighters at a greater disadvantage than normal, compared to exo-armors and exo-suits.

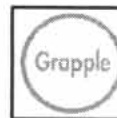

T.E.E

GRAPPLING PROCEDURE ◇

Any unit may be the target of a Grapple, but only units that are Close Combat Optimized may actually initiate a Grapple. Also, Grapples may not occur between units with more than one level of Size difference between them; thus, standard units may not get into bearhug contests with warships. There are two ways to enter a Grapple:

1) A unit may move into close combat with its intended target. Instead of attacking, it declares that it is going to try to Grapple. The defender may counterattack as usual. If the attacker survives, the two units are immediately in a Grapple.

2) A unit defending itself in close combat may, instead of making a counterstrike, choose to Grapple. The two units are immediately in a Grapple.

Evasive units may not initiate Grapples, nor may they be engaged in a Grapple. If a third unit wishes to Grapple with two units already engaged in a Grapple, it only needs to move into contact and declare that it wishes to Grapple. If a third unit moves into contact with two Grappling units and attacks one, the attacked may either counterattack (with the normal penalty for multiple attackers) or add the new opponent to the Grapple.

Place a Grappling counter next to the Grappling units. Remove any Overthrust, Aiming or Evasive counters (see page 34); none of these counters may be placed on a unit that is Grappling. Grappling units do not get an action phase, and thus may not move or shoot; they are completely focused on the immediate situation, and do not have time to deal with the big picture. Grappling units are subject to the same targeting rules as units engaged in normal close combat, i.e. there is an even chance of hitting any unit engaged in the Grapple (note that for Grapples, this rule also applies to normal close combat attacks originating from outside the Grapple).

In the End Phase of each turn, Grappling units roll to determine who (if anyone) has the upper hand in the fight. An opposed Skill test is made; both units add their respective Close Combat Optimized ratings. There are no other modifiers, and Command Points may not be used.

In Grapples, Crippled units halve their Close Combat Optimized rating (rounding down). In Grapples involving multiple units, only one roll is made; add the Close Combat Optimized ratings of all units on one side together, and then roll as normal. If there are more than two sides (assuming that none of the sides is cooperating in the Grapple), each side rolls against each other side.

If the Margin of Success of the roll is 2 or less, neither opponent has an advantage; the units remain locked in the Grapple until the next End Phase, when another roll is made. If the Margin of Success of the roll is 3 or greater, the winning unit(s) gain a temporary upper hand. If one of the opponents Fumbles the Grapple roll, however, the other side automatically wins the Grapple for the turn, regardless of the actual MoS.

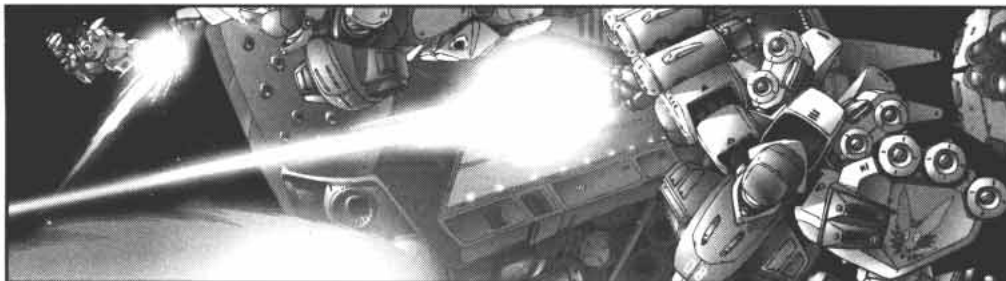



◇ WINNING THE GRAPPLE

The winner of the Grapple may choose to do one of the following (if the winner is not Close Combat Optimized, only options 1 and 2 are permissible choices):

- 1) The winner(s) may move all units involved in the Grapple as one big clump, up to half the winner's normal movement allowance.
- 2) The winner(s) may "present" one of his Grapple opponents to friendly shooters. The winner may rotate the chosen opponent to any facing desired. Until the next End Phase, that opponent may be attacked by other units with no chance of hitting other units involved in the Grapple. Units wishing to attack the Grapple winner (or any other units involved in the Grapple), however, still have an even chance of hitting anyone involved in the Grapple.
- 3) The winner(s) may give one opponent a single Stun counter. If the opponent is a Drone, the Drone is immediately destroyed. As usual, a standard unit that receives two Stun counters is immediately Crippled.
- 4) The winner(s) may make a single attack with one of its weapons, at point-blank range. The attack and Defense Rolls are made as normal. This attack may be used against any available target, not just the Grapple opponent.
- 5) The winner(s) may disengage from the Grapple. Remove the Grapple counter. The winner may be moved up to half its normal movement allowance. Next turn, it moves and acts as normal, as does its opponent(s).

In all of the above cases except 5 (disengagement), the Grappling units remain locked in combat for another turn, unless, of course, one of them is destroyed. The only other way for Grappling units to disengage is for all units involved in the Grapple to announce in the End Phase that they are voluntarily disengaging. If this happens, the Grapple counter is removed, and although the units remain in close-combat distance, they may move and act as normal in the next turn. Close Combat Optimized units Grappling with non-Close Combat Optimized units can disengage whenever they want to.

Close Combat Optimized units may counterattack regardless of the arc in which they are attacked, by using back kicks and other rear-defense tactics. Non-Close Combat Optimized units may only counterattack if they have a weapon in the proper arc.

Evading units may not attack or counterattack in close combat, and may not initiate Grapples. They do, however, receive their defensive bonus against close combat attacks.

■ GRAPPLING EXAMPLE

Exo-armors A, B and C are all on different sides. Exo-armor A is Evading. Exo-armor B activates, Overthrusts, moves into close combat with exo-armor A, attacks and misses. Exo-armor A is Evading, and so cannot counterattack or initiate a Grapple. Exo-armor C now activates and moves into close combat with both exo-armor A and exo-armor B. Exo-armor C chooses to initiate a Grapple with exo-armor B (he cannot Grapple with exo-armor A, because exo-armor A is Evading, and Evading units may not be Grappled). Exo-armor B is allowed to counterattack before the Grapple actually takes effect, and does so. He misses again, and is now in a Grapple with exo-armor C. Exo-armor B's Overthrust counter is removed, and a Grapple counter is placed near the three exo-armors. However, exo-armor A keeps his Evasive counter, and is not considered to be part of the Grapple, since Evasive units cannot Grapple.

In the next turn's Main Phase, exo-armor A decides to move normally. The Evasive counter is removed. Exo-armor A can:

- 1) Move away from the Grapple
- 2) Attack exo-armor B or exo-armor C, joining the Grapple as a third side
- 3) Team up with either of the Grappling exo-armors against the other, keeping the Grapple two-sided.

If exo-armor A had decided to remain Evasive, the two other exo-armors would carry out their Grapple normally, and would not be affected in any way by exo-armor A; they cannot Grapple with exo-armor A, and they cannot attack it otherwise, because they are too busy with each other.

COMMAND POINTS ◀

Command Points represent the commander of a force shouting warnings and directions to his or her troops over the communications net. They allow individual units to take instant Action to respond to danger outside of their normal turn sequence. There are two types of Command Point. Although obtained in different ways, both types of Command Point are used in exactly the same fashion. Players can use colored counters or spare dice to keep track of the number of Command Points they have remaining.



Tactical Command Points are provided to one or more Players at the beginning of the game. Tactical Command Points are kept through the game from turn to turn, although once they are used, they are gone forever. All Players should agree before the game begins how many, if any, Tactical Command Points each Player should receive (one Tactical Command Point for every five units is a good benchmark). Differing numbers of Tactical Command Points may be given to Players in order to represent a handicap.



Initiative Command Points, if used, are 'awarded' to the loser of initiative each turn to offset the benefits of winning initiative, and are also granted every turn by certain special units (like the Jovian Godfire-class ships). Unlike Tactical Command Points, Initiative Command Points are not carried over from turn to turn; if they are not used during the turn in which they are awarded, they are lost.

All Players must agree to use Initiative Command Points before the game begins. After each roll for Initiative, the winner of initiative still gets to choose the order of play in each phase. Each Player who lost initiative receives a number of ICPs equal to the difference between his roll and that of the winner. In order to prevent massive cascades of CPs in small battles, the number of ICPs a Player receives in a turn from any source cannot exceed one-fifth of the total number of units he has in play, rounding down. ICPs may only be used if a fleet has more than one unit left in play; a lone unit cannot warn itself to get out of the way of danger!

COMMAND POINTS USE ▼

Command Points have priority over all other Actions; the only thing that can interrupt a Command Point from taking effect is another. This can occasionally lead to 'cascades' of CPs, where Players will keep preempting each other's Command Points with another Command Point. These should be worked out in order from the last declared CP back to the first, resolving each use before moving on to the next. All the Command Points in a cascade are considered used, that is, if the unit these points are assigned to is destroyed or otherwise unable to make use of the remaining points in the cascade due to damage or the destruction of its target, the remaining Command Points assigned to it are wasted.

STANDARD UNITS ◇

A Command Point may be spent on a single standard unit at any time during the First Ship, Main or Second Ship phases to give it *one* of the following benefits:

- 1) One additional Action, which must be used immediately. This Action does not receive or increase Combination Attack bonuses;
- 2) A single +3 bonus to the next Defense Roll the unit makes;
- 3) A free facing change of up to 180 degrees.

If the exo is interrupted by a Command Point Action while trying to attack, its current facing (which it is using for its attack) is used for targeting purposes.

SPACESHIPS ◇

Ships may use Command Points much like standard units, but with a different set of options. Uses for ships and standard units are *not* interchangeable. A ship may use a Command Point in *one* of the following ways:

- 1) The ship may take one Action immediately. It does not receive or increase Combination Attack bonuses. The Action may be of any type except the Thrust Action, which can only be used as a normal Action in the Second Ship Phase. The ship's Avoidance is affected as normal by whatever Action it ends up taking.
- 2) The ship may immediately change facing up to the maximum arc for its Turning Type. Unlike normal movement, this "emergency move" does not affect the ship's Avoidance.
- 3) A ship's Point Defense System may change mode instantly. This does not affect the ship's Avoidance.



▶ ACES

Be it by skill, experience, courage or plain dumb luck, some pilots and ship crews are noticeably superior to their fellow warriors, sometimes seeming to possess almost supernatural powers of insight, aim or survival against the odds. Such people are represented in **Lightning Strike by Aces**, which are specialized counters that can be assigned to a single vehicle or ship. Players can create these counters themselves, or simply paint the relevant statistics on the base of the Ace's vehicle or ship.

An Ace unit in a Group gets its own counter, and thus will likely have different Skill levels and attributes from the other units in the Group. Otherwise, the Ace follows all fleet-specific rules for Groups (e.g. a Venusian Ryu Ace must always be in a Group of four Ryus) and Morale. Aces are the only pilots who are not standard pilots (i.e. Skill Level 2, Skill bonus 0).

Each Ace counter should have several noteworthy characteristics. Aside from the character's name, Skill level and Skill bonus, there may be an additional symbol on the front of the counter, which denotes a special ability or characteristic the Ace possesses, such as an exceptionally quick mind or a sixth sense. These characteristics are called **Perks**.

Aces must be purchased before a battle, and they must be assigned to a single vehicle or ship. Up to 10% of a force's total TV may be spent on Aces. Before building their fleets, players should agree on whether there should be a limit to the number of Aces a fleet may have, and they should agree on a maximum cost for Aces. (A suggested limit is one ace for every ten units, with a maximum cost of 35.) *Unlimited use of Aces can drastically unbalance a game, and is not recommended.*

▼ ACE PERKS

All Aces get two automatic Perks just by virtue of being Aces. Of most importance is the **Parting Shot**, by which an Ace is allowed a final Action after being destroyed, possibly resulting in a double-kill. Nothing can prevent this final Action. Even if the Ace is massively Overkilled (or caught in a ship reactor explosion), he or she will still get to take one last Action. This Action must be taken at the moment of the Ace's destruction, and supersedes both the normal turn sequence as well as Command Point usage. Aces also automatically get to use **Command Points**, regardless of enemy ECM activity (a solitary Ace with no one else left on his side still can't use Initiative Command Points, however).

In addition to these automatic Perks, an Ace may have one special Perk, purchased from the list below.

Aura of Command: when the Ace speaks, people listen. As long as the Ace is not destroyed, his side receives an additional Initiative Command Point at the start of every turn. Cost: 10

Blind Luck: either by skill or chance, things just always seem to work out for this Ace. This remarkable individual can accomplish even seemingly impossible tasks. When the Ace makes die rolls, he may choose to convert any one die that rolls a five into a six. Cost: 5

Charmed Life: the Ace has spectacular karma. Point-blank shots veer off course, destroyed systems mysteriously come back on-line, and every conceivable mishap seems to miss the Ace by a millimeter. The number on the Ace counter represents how many dice rerolls the Ace has available each battle. When the Ace fails a roll of any sort, he may use one of his dice rerolls to try the roll again. Cost: 1 per reroll (max. 5 rerolls)

Inspirational: the Ace's piloting Skills may not be the greatest, but he makes up for it by encouraging everyone around him to be all that they can be. All other non-Ace units in the Ace's Group get a Skill bonus of +1 as long as the Ace is neither Crippled nor destroyed (if the Ace is in a ship, this ability works as long as the ship has taken fewer than 8 boxes of damage). Cost: 10

Lightning Reflexes: the Ace moves with both speed and efficiency, doing more in a few seconds than most people can do in a minute. The Ace gets an additional Action, above and beyond the normal number of Actions available to his vehicle or ship. Cost: 10

Melee Master: the Ace has gained impressive Skills in the dangerous art of close combat. The Ace adds 2 to his vehicle's Close Combat Optimized rating. This Perk has no effect for non-Close-Combat-Optimized vehicles. Cost: 5

Nerves of Steel: the Ace is a highly-trained sniper. When the Ace takes an Aiming counter, the bonus to his attack roll is +2 instead of the normal +1. In addition, the Ace may fire into close combats with no chance of hitting a friendly target. Ship crews cannot take this Perk. Cost: 5

Quick and Wily: the Ace always seems to know where the next attack is coming from, and moves with fluid grace to avoid it. The Ace gets a +1 bonus to all Defense rolls. Cost: 5

Sixth Sense: this Perk is assigned to warship crews. At the end of the first ship phase, the ship may make a single free turn up to its normal Turning type. In other words, a ship with Average Turning may make a free turn of up to ninety degrees, while a ship with Sluggish Turning may only make a turn of up to forty-five degrees. Cost: 5

ACE CREATION RULES ▼

The cost of an Ace is modified by the type of vehicle the Ace is assigned to; an Ace crew in a Shan-Yu battlecruiser is worth much more than an Ace in a Syreen. In the above list, each Perk has a Cost associated with it. To create an Ace, simply decide what Skill Level, Skill Bonus and Perks your Ace will have. Calculate the new Ace's cost as instructed below. Name the Ace, create a few punchy one-liners to deliver in battle, and the Ace is ready to go.

The Ace's Basic Cost represents his Skill Level and Skill Bonus. Use the following table to find the Ace's Basic Cost multiplier. For instance, the Basic Cost of an Ace with a Skill Level of 3 and a Skill Bonus of +1 would be 16.

ACE BASIC COST MULTIPLIER □

Skill Bonus	0	+1	+2
Skill Level One	-4	-2	0
Skill Level Two	0	5	12
Skill Level Three	8	16	25
Vehicle Modifier = Base TV of Ace's vehicle or ship, divided by 5 (round up)			
Ace's Total TV Cost = Basic Cost + Perk Cost + Vehicle Modifier			

To complete the example, let's say the Level 3, Bonus +1 Ace from above has Nerves of Steel and will be assigned to a Pathfinder (TV 8). The Vehicle Modifier is 8 divided by 5, which equals 1.6, rounded up to 2. The sum of the Basic Cost, the Perk Cost and the Vehicle Modifier is 16 + 5 + 2 = 23. The Ace thus has a TV of 23. The Ace and his Pathfinder together cost 31, which seems expensive for a Pathfinder until one considers that he will consistently roll 6's and 7's, virtually never Fumble, and gets a +2 bonus when Aiming.

ELECTRONIC WARFARE ◀

Some units are equipped with complex suites of electronics allowing them to interfere with their enemies' communications. These **ECM** (Electronic Counter Measures) systems consist of jammers, white noise generators and other devices that can only be effectively canceled out by dedicated **ECCM** (Electronic Counter Counter Measures) systems. Units equipped with ECM and ECCM are marked as such on their Datacards; the full rules for Electronic Warfare equipment can be found in Chapter 6, page 62.

Few warships use electronic warfare, because doing so tends to greatly reduce a ship's Avoidance. However, all ships do have the ability to use both ECM and ECCM by virtue of their onboard electronic systems and high power computers. Ships with damaged or destroyed Electronics may not use ECM or ECCM.

Any ship may spend an Action to use ECM or ECCM. A ship can choose an EW Rating, from 1 to 6 (if using Targeted ECM, the chosen Rating must be at least 2). If the ship is using ECCM, the chosen Rating is also the Avoidance cost to the ship. If the ship is using ECM, the chosen Rating is subtracted from the ship's Base Avoidance; the ship's Base Avoidance keeps this penalty until the ship ends a Second Ship Phase without spending an Action to maintain the ECM.

The exception to this rule is ships that have ECM or ECCM listed as a separate Perk (for example, the Godfire or Hammerhead); such ships may use their specialized EW Perks at no Avoidance cost, since the systems' signature has been taken into account when the ship was designed.

4.3.2

4.2



► INFANTRY

Infantry has always been the central unit of ground warfare; even in space they have their place. Used by every nation, these soldiers are equipped with spacesuits, jetpacks for mobility and small arms. While deadly in the close confines of a spaceship's corridors, they are slow and near-helpless while moving through open space. Their armaments are too light to be of use against anything but other infantry, save for their demolition charges which are used to blow access holes in ship hulls. Amid the mighty warships and exo-weapons that litter the modern battlefield, infantry are less than nuisances, but in their element, they can be deadly.

Infantry may move two centimeters (2 cm) per turn in any direction. Like exo-suits, they have no facing since the men can fan out to cover every direction at once. Infantry have only minimal reaction mass reserves and may not Overthrust, Aim or Evade. Like Drones (see page 67), Infantry are destroyed by any damage received if they fail their Multiple Redundancy Perk roll (see page 60). When choosing forces from the fleet lists, Infantry do not count as either units or vehicles for fleet limitation purposes.

► BOARDING ACTIONS

An exo-suit or infantry unit in close combat with a ship may attempt to board it and damage it from the inside. The unit must declare its intention to attempt a **Boarding Action** before taking its Action(s) for the turn. The unit must pick a component through which to enter the ship, and must attack that component with its Action. If the attack damages the component at all, no actual damage is inflicted (regardless of the severity of the hit) but a hole is blown in a door or hatch and a number of exo-suit or infantry squads up to the ship's Size may now enter the ship. Units that have boarded a ship should be removed from the playing field and placed on the boarded ship's record sheet.

On the turns following the actual boarding of the ship, a battle for control of the vessel will take place in the corridors and rooms of the ship. The boarded vessel's crew may try to fight off the invasion. Also, if there are any friendly infantry or exo-suit units aboard the ship at the time of the boarding, they may engage the invaders in close combat using the intermediate close combat rules (see page 36) during their Action phases.

If any defending exo-suits or infantry squads are aboard the ship, they must be destroyed in close combat or driven off the ship entirely before Actions may be spent to damage the ship itself. Every turn, for its Action, a boarding unit may attack any unit on the ship as if it were in close combat.

If there are no friendly infantry or exo-suit squads aboard the ship, the invaders have free run of the ship. The boarders may use their Action to set demolition charges. The boarders roll an opposed Skill test against the ship's crew. The boarders may add any Close Combat Optimized bonuses, while the ship's crew gets no bonus. If the boarders win the roll, they may choose a single system or component, which is immediately Overkilled (they may, if they choose, do less damage). If the ship's crew wins the roll, then the boarders only manage to mark off one damage box in a system or component of their choice. If the boarders fumble the roll, they get caught in one of the crew's booby traps and are destroyed. As a final option, boarders may spend their Action to leave the ship (a wise choice, if they've just blown up the reactor).

Units firing on a boarded ship run a chance of damaging or destroying the boarding party along with the ship itself. Any time a ship system or component is damaged by an outside attack, any boarding units are Stunned, and any time a ship system or component is Overkilled by an outside attack, any boarding units are Crippled. Note, however, that a squad's Multiple Redundancy characteristic may be used to attempt to ignore all of these damage results.

Rather than making its own entryway into a target ship, a boarding party may allow some other unit (hopefully with a larger weapon) to perform that task. Any unit may declare that it is attempting to create an entrance for a boarding party (i.e. aiming its attack for an internal corridor or room). The attack is made just like a normal boarding attack (i.e. no damage, hole cut in hull). The boarding parties must enter through this hole in the same turn in order to maintain the element of surprise. If they do not, then a new hole must be made in the next turn, since damage control crews will have already sealed off the damaged section.

OBSTACLES ◀

Due to the fact that most pitched space battles take place around large stationary objects (in order to provide both admirals with a frame of reference), many space battlefields are littered with the detritus of industry and civilization. These objects are collectively known as **Obstacles**.

If Players decide to use Obstacles in a game, each Player should get to place an equal number of Obstacles on the table. Obstacles can be used to block LOS but otherwise pose no threat to anyone, having no Actions or defenses. Each Obstacle counter is considered to actually be in scale with the table. Thus, unlike ship counters, any contact with an obstacle counter results in that unit being affected by the obstacle. For the purposes of this rulebook, obstacles may not be destroyed. There are five types of Obstacle in the basic game:

Asteroids: Asteroids are big — really big. An asteroid is in scale with the table, so a rock 10 cm in diameter represents an asteroid five kilometers wide. Asteroids block Line of Sight completely, and are the only Obstacles in the game that do so; no matter how far away two units are from each other and the asteroid, they cannot draw LOS to each other if the asteroid is between them.

Dust Clouds: These vast areas are filled with electromagnetic radiation-absorbing dust. Any ship that moves into a dust cloud may increase its Avoidance by 1. If the ship is still in the dust cloud in the End Phase, it gets another +1 to its Avoidance. Exo-armors, fighters and exo-suit squads inside a dust cloud get a +1 bonus to their Defense Rolls.

Debris Fields: These are like dust clouds, but are made up of larger objects. In game terms, they work just like dust clouds, with one addition. Units entering a debris field must make a Skill check against a Threshold of 2. If the roll is failed, the unit takes a single Crippling hit to a randomly-determined system or component as it collides with a floating piece of debris at high velocity.

Factory Complexes: These are huge arrays of robotic zero-gee manufacturing complexes. They inflict a -2 Accuracy penalty to units attempting to fire into or through any part of the complex. They do not penalize units that are firing from inside the complex, however. Factory complexes do not have any penalties associated with entering them.

Rock Fields: These are dense manmade fields of depleted mining asteroids. They inflict a -2 Accuracy penalty to units attempting to fire into, out of, or through any part of the rock field. Units entering a rock field must make a Skill check against a Threshold of 2. If the roll is failed, the unit takes a single Crippling hit to a randomly-determined system or component.

INSTALLATIONS ▼

Space stations, skyhooks and cargo barges all fall under the category of **Installations**. Installations are essentially ships with no movement capability (although barges do technically have propulsion systems, their movement is so slow as to be unnoticeable in the game). Installations may have vector counters, to simulate an orbiting station moving through a battlefield. Simply move the installation every turn, just like a ship with a vector counter. Before the game starts, Players should agree on the distance the installation should be moved each turn (something between 5 and 15 cm works well). Because they do not maneuver, any component on an installation may be targeted at any range, regardless of the attacker's Electronics Rating.

Installations generally not have Threat Values. However, if Players want to have a station on the table that is firmly on one side, providing supporting fire, vehicle repair and other resources to one Player and not another, a Threat Value will be required. Based on the agreed-upon stats and the objectives of the game, Players should agree upon a reasonable Threat Value. Keep in mind, however, that the installation is mostly terrain, and should not make up the bulk of one side's force; that's why the Threat Value can be so freeform depending on the scenario's objectives.

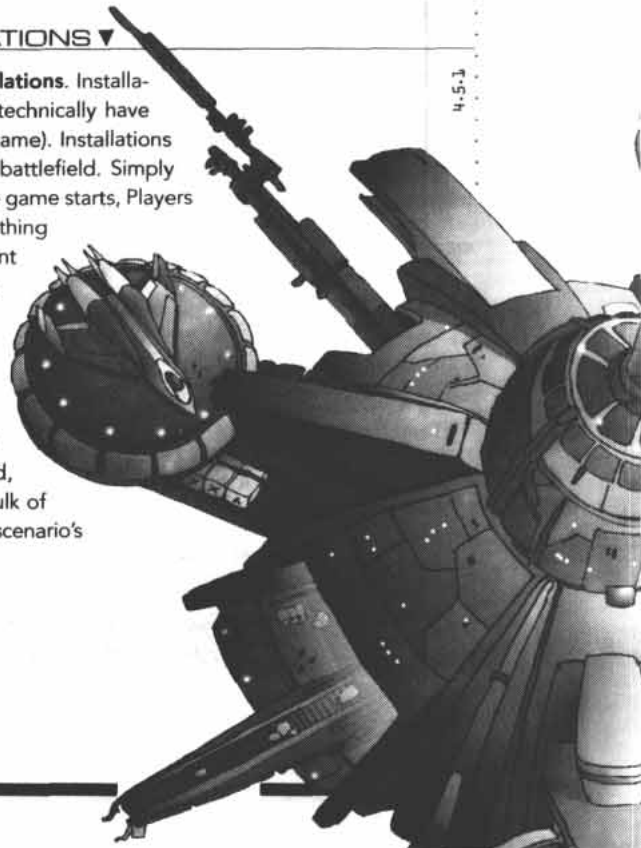



4.5.2



▼ LOW ORBIT

Much of the action surrounding a planetary invasion takes place in low orbit. Shuttles make reentry runs, orbital bombardments fire on targets far below, and defending skyhooks and space stations desperately muster defenses. For ease of play, however, many factors of low orbit combat are abstracted in **Lightning Strike**. When playing a battle set in low orbit, the following conditions apply to the entire battlefield.

Nominate one edge of the table as the "planet" edge. Any unit that moves off this edge is considered to have entered the process of reentry. Non-reentry-capable units are automatically destroyed. Reentry-capable units may do nothing at all; leave them at the edge of the table. In the End Phase of the turn after a unit begins reentry, remove it from the table; it is now into the atmosphere decelerating, and is out of range and line of sight. Until the reentering unit is removed entirely, however, it is very vulnerable to attack; any attacks against it gain a +2 modifier to hit and count as Armor Destroying.

Orbital installations and obstacles will either all be stationary or will all have the same vector, moving along the planet edge of the table. The distance moved may vary, but values between 10 and 40 cm are workable, if not terribly realistic. Ships with destroyed drives gain a vector counter oriented toward the planet edge.

▼ MINEFIELDS



4.5.3

A **Minefield** is a group of passive sensor packages attached to large bombs. Mines have some stationkeeping thrusters, a single solid-rocket booster that is activated when a target is detected, and a torpedo-style directed-burst warhead. Mines are dropped in large clusters, which subsequently break apart and spread a web of several dozen individual mines over a large area of space. On a strategic level, minefields are almost useless, since it is impossible to mine an area of space so large that an enemy cannot find a way around. Once the location for a battle is reasonably certain, however, the presence of a minefield can be a useful tool for influencing enemy movements and shielding friendly units from close assault.

Modern minefields contain an assortment of mine types and decoys in order to be most effective against a variety of interlopers. Mines are equipped with friend-or-foe identification systems that prevent them from attacking friendly forces. However, these systems rely on the friendly unit having an operational communications system. If a unit is for some reason unable to identify itself to the mine Executor's satisfaction, it may find itself under attack from its own side's mines.

For the purposes of the game, it is assumed that minefields extend above and below the plane of the battlefield, preventing units from moving over or under them without going significantly out of their way.

Mines are considered Class I Drones and have a Skill Threshold of 7. Because they take up more space and require special equipment, mines can only be deployed from ships, never from standard units. Dropping a single mine is equivalent to dropping three normal Drones, i.e. a Rate of 3.

Once dropped, a mine will remain in place until the start of the end phase of the current turn. At that point, remove the mine counter and replace it with a minefield. Any enemy target inside the minefield will be immediately attacked. Any units located in a previously-deployed minefield are also attacked in the End Phase.

A minefield template is a circle ten centimeters in diameter, and is considered in scale with the tabletop (i.e. about five kilometers in diameter). It will immediately attack any enemy unit that enters it, interrupting the normal turn sequence. If the defender's roll fumbles, the minefield is depleted (the unlucky target has probably managed to hit every mine in the field) and is removed. Otherwise, a minefield may attack any number of units in a turn. There is no danger in moving within or leaving a minefield, except that in the end phase, a minefield will attack any hostile units that remain within the template.

Minefields usually do not attack units on their own side, so units may move through friendly minefields without difficulty. However, Crippled standard units, ships with Overkilled Electronics and any unit affected by hostile targeted ECM will be mistaken for the enemy and attacked as normal.

If a unit is attacked by a minefield while it is in close combat (or any other physical contact) with one or more other units, all units involved in the close combat will be attacked by the minefield.

Although minefields are inherently difficult to destroy, due to their stealth, dispersion and intelligence, minesweeping is not an impossible task, given time and the right tools. Minefields can be attacked just like any other unit; however, in close combat, they always get to make their automatic attack first.

NOISEMAKER SHROUDS ▼

A **Noisemaker Shroud** is a specialized type of minefield designed to conceal movement and block lines of sight. Shroud pods disperse huge clouds of radioactive dust and reflective particles, and also broadcast random signals and ghost traces. Used properly, shrouds can be an invaluable asset in battle.



Shrouds are considered Class II Drones, and are carried and dropped just like mines, using a Rate of 3 per shroud. However, a shroud's template is a circle 20 centimeters in diameter.

Line of sight to and from any object within the shroud's template is blocked from the moment it enters the shroud until it leaves. No missile locks, pings, tagging attempts, target designation, targeted ECM or attacks may be made by or against the unit. Units within the shroud may not use Command Points.

Units inside a shroud may be attacked in close combat as normal, but only if the attacking unit first passes a Skill roll against the shroud's Skill Threshold. If the roll fails, the combatants have completely lost each other inside the shroud. Overlapping shrouds are considered a single large shroud; effects are not cumulative.

The shroud has no effect on any attacks that only pass through it, without actually coming from or being aimed at a unit inside the shroud. Only units that are actually inside the shroud are helped or hindered by it. In other words, it's permissible to shoot //through// the shroud, as long as the attack doesn't begin or end in the shroud.

Minefields located entirely within a shroud may not be attacked, except in close combat. If an impartial mediator can be found, Players can use shrouds to hide minefields entirely, not placing a minefield on the table until an enemy actually runs into it.

Shrouds may be attacked when they are first deployed. After the shroud template is placed on the table, the shroud is invulnerable from all battlefield effects, unless a ship that is physically inside the shroud undergoes a reactor detonation; if this happens, the shroud is removed from the table. Shrouds may not be used in low orbit.

RAMMING ◀

Usually an act of desperation, ramming is actually a very effective combat maneuver, considering the amount of thrust most battlefield units are capable of generating. The difficulty, however lies in persuading a pilot to impact his vehicle into a target at high velocity, quite possibly resulting in his death.

Any unit may ram. Ramming is not counted as an Action, and may thus be performed even if a unit is Evading. To ram, a unit must move into base-to-base contact with its intended target. Then, a Skill roll against a Threshold of 5 must be made, to represent the possibility that the unit's crew may simply refuse to willfully scuttle their vehicle on the orders of their commander. If the roll fails, then the ram attempt is aborted, and the unit ends up in close combat with the target. A unit may only be ordered to ram once per game, no more.

If the roll succeeds, then the unit immediately attempts to ram its target. A normal attack roll is made, but the only modifiers are the pilot's Skill Modifier and the ramming unit's Avoidance value. The defender gets a normal Defense Roll, with all applicable modifiers, but only if the defender is capable of movement. If for any reason the defender is unable to move, its roll is automatically zero, and the attacker's Margin of Success is automatically at least one (unless, of course, the attacker fumbles). It's not hard to run into a stationary object.

A unit inflicts an amount of damage equal to its Size plus half (round down) the total distance it moved in centimeters that turn, multiplied by the Margin of Success of the ram. Both units involved in the ram inflict damage on each other in this manner. Ships ramming ships always impact on the Main Hull (and each Player may choose which system on his opponent's ship to damage). Standard units ramming ships may choose any Main Hull system or Component upon which to inflict the ram damage.



► LIGHTNING STRIKES

Despite this game's title, the use of lightning strike tactics in **Lightning Strike** is extremely abstracted. A lightning strike takes place when a vehicle applies massive and constant acceleration while still far away from the battlefield, such that by the time it is in weapons range of the battle, it is traveling at an extremely high velocity in comparison to the rest of the combatants. A lightning-striking unit will enter the battlezone, attack, and vanish into the distance in the space of a moment or two. Such an attack gets only one chance to inflict damage, but is also correspondingly difficult to counter.

Rather than force Players to keep track of every single shot fired in a lightning strike situation, this game uses the concept of the Lightning Strike Value, or LSV, to determine the effectiveness of a lightning strike. There is no need to specify what types of units are actually going to strike; Players may simply purchase LSV points at the rate of one LSV point per TV point, and use them as described below during the game. Unless all Players agree otherwise, no Player may spend more than ten percent of his total TV allowance on lightning strikes.

In campaigns, Players may purchase LSV points before a scenario is played, but may not spend more than ten percent of the TV allowed by the scenario on lightning strikes. Also, the LSV cost for a scenario cannot be more than the total TV of all the units in the portion of the fleet that is not participating in the scenario.

For example: a Player with a 500-TV fleet is playing a campaign. The scenario allows him to use up to 500 TV of units. The Player can choose to not use lightning strikes, in which case he can put his entire fleet on the table. If he chooses to use lightning strikes, he can purchase up to 50 points of LSV (ten percent of the total TV allowed by the scenario). If he takes 50 LSV points, he will have to choose 50 TV worth of units to leave off the table (those are the ships and units that will actually be doing the lightning striking). If the Player only purchases 20 LSV points, he will only have to choose 20 TV worth of units to leave off the table.

▼ DURING THE GAME

Before the battle, each Player must secretly decide in which turn (or turns) the lightning striking units will pass through the battlefield. The total LSV may be divided in any manner, between any number of turns. Lightning strikes that arrive after the game ends are wasted. For example: a Player has purchased 30 LSV points. He decides to use 10 points in turn 3, 15 in turn 7, and 5 in turn 12. As it turns out, the game ends on turn 10. The 5 LSV points assigned to arrive in turn 12 are wasted, since they will arrive after the battle is over.

In each Initiative Phase, all Players must announce how many LSV points will be used in that turn, according to their LSV point decisions before the game began. At this point, a Player may also choose to abort that turn's lightning strike; the strike is canceled, and none of the events described below will occur. The lightning strikes themselves are resolved at the beginning of the End Phase, before minefields act.

Throughout the turn, any unit may attack the lightning-striking units by making a standard attack roll at maximum range. The Defense Roll is always an unmodified Skill roll on two dice. Over the course of the turn, a record must be kept of the total damage inflicted on the lightning-striking units. This damage has no effect until the end of the game.

In the End Phase, the lightning-striking Player may choose as many targets as he likes, so long as at least one LSV point is assigned to each target. When all LSV points are allocated, the attack rolls are made. Each target makes a normal Defense Roll; the attack rolls are all unmodified Skill rolls on two dice. The LSV points assigned to a target are treated as the Damage Multiplier for a successful hit.

▼ AFTER THE GAME

At the end of the game, each side adds up the total amount of damage inflicted on its lightning-striking units throughout the entire game. Divide this total by 10 and round down. In a one-off game, the result is the number of Victory Points lost due to damage to the lightning-striking units.

In a campaign, the result is the number of Cargo Points required to repair the damage to the lightning-striking units. The Player *must* remove this amount of Cargo Points from his fleet's stockpile. If the fleet does not have enough Cargo Points remaining, then each unpaid Cargo Point is applied as a single Crippling hit to one of the fleet's units that did not fight on the table in the battle (i.e. any units that may have been lightning striking instead of fighting normally). The owning Player may distribute the damage however he likes. Once the number of units destroyed in this manner equals or exceeds the Player's original LSV for the battle, any further damage is ignored.

4.7

4.7.1

4.7.2

ELEMENTS OF SURPRISE ◀

"We're late," Ling noted. Ahead of them, even though the naked eye would see nothing but empty space, Ling knew that over a dozen warships lurked about, waiting for opportunities to kill each other. After the initial summons, the fleet had remained silent, most likely in an effort to keep hidden. Looking at his tactical screen, though, Ling could clearly see which enemy ship most needed his attentions. There, sitting in the midst of several light escorts, was an unprotected Poseidon-class battleship. Ling smiled.

"Hey, folks. Maybe Admiral Lin isn't so clever after all."

"Don't speak too soon, Ling," Helena reproached. "You also said that they'd be nuts to ambush us in their own search zone."

"Fine, fine, whatever," Ling said dismissively, focusing on the current target. "Okay, here's the plan. Two waves. Fighters harass, exos close to do some pruning. After that, it's all yours, respected elder."

"Sounds good," Helena replied, obviously ignoring the barb. "My wing, stand by."

Ling and his three wingmates headed toward the Poseidon. The huge battleship opened up with its kinetic kill batteries, filling space with hypervelocity slugs. Ling wove and dodged, closing the distance while sidestepping death. The Dragonstriker may have deprived him of a ranged attack, but Ling hadn't been planning on shooting the Poseidon, anyway.

His exo's giant manipulator hand reached down and drew a slim metal tube from a hidden compartment. Ready himself, Ling hurtled into the last few kilometers of his approach. Over his head streaked missiles from Helena's wing of fighters. The battleship's point defense lasers deftly shot down each missile before it could hit, but failed to pay enough attention to Ling. In moments, he was skimming the Poseidon's hull, safe from attack.

Ling hit a trigger, and from the tube clutched in his exo's hand sprang a white-hot stream of superheated gas. Ling swept the fiery plume down toward the ship's surface, aiming in particular for the clustered point defense projectors jutting from the hull. When he and his wingmates finally broke off, the Poseidon's entire side was aglow with plasma burn. Looking back, Ling saw Helena's Lancer wing charging in on the last moments of their bombing run. He faced forward and accelerated away.

Behind him, a bright flare marked the demise of the Poseidon's primary reactor. The massive ship glowed like an ember on his tactical screen as its crew tried desperately to stabilize the volatile plasma combustion chamber. A fly-swarm of escape pods launched from the dying vessel, hurtling out into the middle of the battlefield.

Helena's voice whooped cheerily over the comm.

"Target is clear. Okay, it's all up to Sanjay, now. It's back to the box for us."

Ling couldn't resist.

"Helena, there's something I've been meaning to ask you."

"What is it, Lieutenant?" Helena asked in exasperation. Ling smiled cheerfully.

"When a stranger in an old exo kicks your tailpipe that badly, do you have, like, a blanket or something that you can hug at night?"

Helena waited until Ling was inside the bay before answering.

"Ling, when you dismount, I'm going to hurt you."

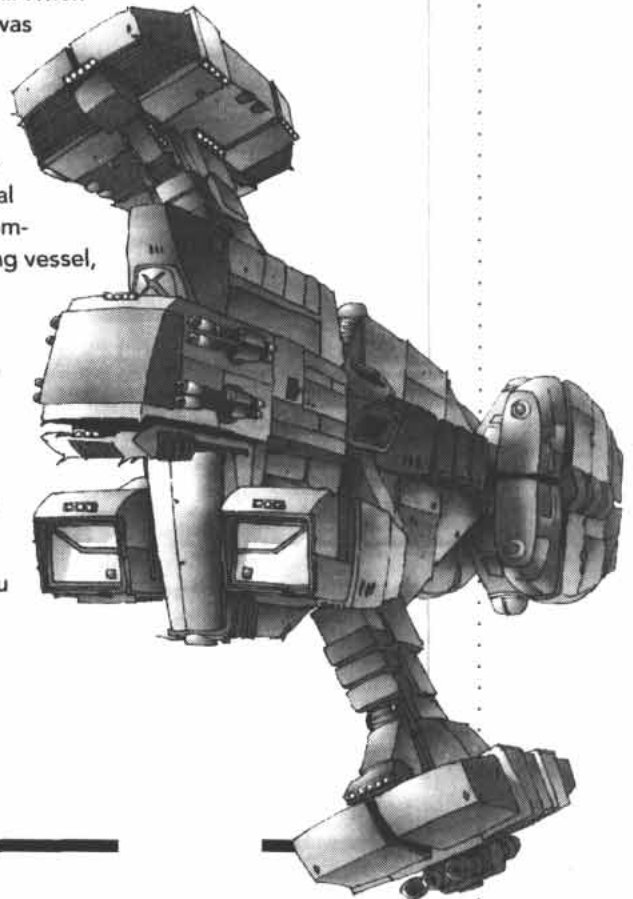



5.1



► SCENARIOS AND CAMPAIGN

Welcome to the Jovian Armed Forces Advanced Warfare School. The public and the media call us Redeye. As far as you're concerned, sir, this is Hell. You'll eat when I tell you, and sleep when I tell you. By the way, if you think a holographic simulator and practice ship aren't close enough to reality for you, you're in for a shock. See that wall over there, the one with all the names? Those are...

...the names of all the vac-suckers who couldn't hack it in the sims. The rank of CEGA Admiral isn't for everyone, and frankly, looking at the statistics, sir, it's probably not for you, either. But hey, if you want me to bust you up for a few months, I'm happy to oblige. Keep in mind, though: nobody fails you out of the Admirals' College except yourself. Either you stay until you're good enough to leave...

...or you walk out of your own free will. That is because the first mark of a true leader is to finish a struggle of your own accord. If you leave the Kanagawa Military Science Institute, the dishonor is all your own. Yes, honored superior, I do know who you are, and I know your wealth and connections. They do not matter. Here, nothing matters, except your ability as a soldier. Let us begin. I will start a fight. Let us hope you can finish it.

In the cold-war détente of 2214, sending fleets out to rattle sabers and wave flags is a dangerous and risky undertaking. Many would-be admirals are poor diplomats, or too aggressive, to be safely trusted with the preservation of peace. This is why every active fleet in the solar system is led by an individual who has undergone the most grueling and rigorous training and study in their nation's top military educational establishments. Although the battles in these schools are simulated and relatively safe, the tactics, strain and uncertainty are quite real. All of the Solar Nations run their flag officer candidates through the scenarios in this chapter over and over again, practicing new strategies and searching for previously undetected weaknesses.

In this chapter, Players take on the role of a prospective flag officer in their nation's navy. They will create fleets and lead them in a variety of battles. In this environment, fleets from the same nation can meet each other in battle, and fleets that come from opposing nations may be seen cooperating. After all, when studying war, it is a good idea to plan for every eventuality.

▼ SINGLE GAMES

5.1.1

When Players simply build a fleet, play one game and then call it quits, the procedure for generating a scenario is quite simple. Players should agree on a TV total and purchase fleets using the fleet lists (see Chapter 7). The total TV is used to determine the TV restrictions for Aces and equipment. After all Players have chosen their forces, a scenario should be chosen (either randomly or by group agreement). Players can choose one of the basic game scenarios on this page (which are meant specifically for quick, deadly one-off games), or they may pick any of the campaign scenarios (treating its TV requirements normally).

When choosing a scenario or setting up Obstacles, Players should either agree to work together, or they should establish some fair method of distributing the workload (e.g. each Player gets to place an equal number of Obstacles). When setting up the forces on the table, Players can take turns placing one ship or Group so that no one has to commit to a setup before anyone else. There is no practical TV limit for the basic scenarios; they will work equally well for forces of almost any size. Note that it is also possible to just purchase equivalent forces, set up on opposite sides of the table and then rush at each other. However, such a battle can often drag out due to the lack of a defined objective to strive for.

◇ BASIC SCENARIO 1: THE MCGUFFIN SCENARIO

You'll find yourself receiving lots of orders that don't make sense. Go here, take this, stop that, et cetera. When all's said and done, that's your job, to do what you're told. Sure, you're a big-shot admiral. You know what you'll get told when you ask why you're supposed to do something stupid and meaningless? They'll say: don't ask. And I'll guarantee that the person to tell it to you will be some punk enlisted rating.

Setup: Place one asteroid, neutral vehicle or some other marker right in the middle of the table. This point in space is the McGuffin; everybody wants it for themselves. You don't care what it is, or why you want it; all you want to do is keep everyone else away from it. Any number of other Obstacles can be placed, depending on the Players' preferences. All Players set up their forces within 20 cm of the table's edge, as far away from one another as possible.

All Players' Objective: You must move at least one unit onto the McGuffin. You must keep this unit from being destroyed. At the end of the third End Phase in which this unit occupies the McGuffin, you win.

BASIC SCENARIO 2: THE HOT FLASH SITUATION ◇

The media says we're at peace. If you're dumb enough to believe them, you can write your name on the washout wall right now. It's happened before, and it'll happen again: two patrolling fleets bump into each other, say a couple of naughty words, and before you know it, they're shooting at each other. Sure, it's an act of war. But these little incidents help us keep up with how good the bad guys are, and they always get stopped within a few minutes. So far.

Setup: Any Obstacle setup can be placed, depending on the Players' preferences. All Players set up their forces within 20 cm of the table's edge, as far away from one another as possible.

All Players' Objective: Destroy as many enemy units as possible while losing as few units as possible. At the end of the 12th turn, all sides receive an order to cease fire and withdraw peacefully. The game ends at this point. Total up the TV of all the enemy units you've destroyed, and then subtract the total TV of all of your units that were destroyed. The Player with the highest result is the winner.

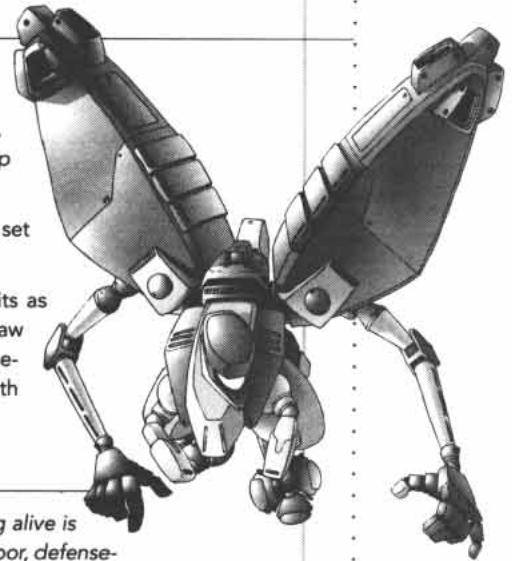
**BASIC SCENARIO 3: THE ST. BERNARD EXERCISE** ◇

Of course you're good at staying alive. You wouldn't be here, otherwise. Problem is, staying alive is not your major priority. Keeping other people alive is. When you're ordered to escort some poor, defenseless ship out of a combat zone, you'd better be ready to climb out an airlock and stop incoming rounds with your gloved hands, because if you screw up, and the media find out, you'll wish you were dead.

Setup: The table is split into two halves, the Attacker side and the Defender side. All Players must decide before the game begins which side they will be on; roll randomly, if necessary. For more than two Players, divide up the TV total of each side and distribute it among the Players. The Attackers get to place all Obstacles. The Attackers may set up along one edge of the table, within 20 cm of the table's edge. The Defenders may set up anywhere on the table except within 30 cm of the Attackers' table edge.

Special Rules: The Attackers receive one Ebiiru-class ship for every 100 TV (or fraction thereof) in their force; these ships may not have any equipment or Aces assigned to them.

Attacker Objective: You must move all of your Ebiiru-class ships off the opposite edge of the table; the moment you do so, you win. If some (but fewer than half) of the transports are destroyed, you win a marginal victory.

Defender Objective: You must destroy all the Attacker's Ebiiru-class ships to win a total victory. If you destroy at least half of the transports, you win a marginal victory.

BASIC SCENARIO 4: THE ALAMO EVENTUALITY ◇

Sometimes, you just can't win. No bluster here, sir. The final test of any admiral is how he faces death, and I can't teach you anything about that, because no matter what you do, you won't have to answer to anyone in this life. My opinion, though? When you're at the pearly gates, your opponent had better be right behind you, and you'd better be the one to tell St. Peter "you ought to see the other guy."

Setup: The defender gets place all Obstacles. As in Scenario #3, there is an Attacker side and a Defender side; all Players must choose a side, and the side's TV total must be divided among its Players. The Attackers get twice the TV total of the Defenders. The Defenders may set up anywhere on the table. The Attackers may set up on any or all table edges, within 10 cm of the edge.

Special Rules: The Defenders are not subject to their fleets' Morale rules.

Attacker Objective: Wipe out the Defenders. Total up the TV of all the enemy units you've destroyed, and then subtract the total TV of all of your units that were destroyed. The Player with the highest result is the winner.

Defender Objective: Destroy more than your total fleet TV worth of enemy units. If you hurt them more than they hurt you, you win.

5.2

▶ THE CAMPAIGN

A campaign is a series of games that follows the exploits of a single fleet of ships. Any number of Players may participate in a campaign. Either Players may ally, splitting the TV cost of each scenario, or they may engage in a free-for-all, in which every Player fights against every other Player in a randomly-determined series of battles. Players may decide on any stopping point before beginning the campaign. A suggested stopping point is when all Players have played ten games. The Player who accumulates the most Victory Points is the campaign's winner. If they wish, Players can keep the same fleet throughout several campaigns, building their fleet's experience and reputation.

▼ CAMPAIGN STATS

5.2.1

All units and ships in Lightning Strike have traits that are not relevant on the tabletop, but which are of vital importance during a campaign. These values appear at the bottom of each ship's data card; the values for standard units are defined by their classification in their fleet list.

Repair Value: This represents the difficulty of repairing and resupplying the unit. Some vessels, like the Ebiiru, are well-known, modular and very common, making them easy to put back together. Other ships, like the Poseidon battleships, are cranky and take much more time and equipment to repair. The value is the number of Cargo Points needed to repair each section of the ship. For standard units, the Repair Value is noted on the table on page 54, and represents the number of Cargo Points needed to repair the unit.

Fleet Maneuver: This defines how good the ship is at moving from one battlezone to another while remaining in operating condition. Some ships can move fast, while others are extremely simple to repair. Ships that have both of these qualities tend to have high Fleet Maneuver ratings.

▼ ASSEMBLING THE FLEET

5.2.2

All Players start out with the same total Threat Value. A small fleet is 750 TV, a medium-sized fleet is 1500 TV and a large fleet is 2500 TV (the default recommendation is 1500 TV). Each Player must choose a nation and build a fleet according to the rules given in that nation's fleet list (see Chapter 7, page 74).

Both ships and standard units may be purchased with Options. Ship Options may not be changed once the campaign begins. For standard units, a Player may only buy Options that cost TV, not ones that reduce TV. A Player may buy multiple Options for a given standard unit (like a Pathfinder or Wyvern), and switch Options before each battle. Note the available Options for each unit type on the Fleet Roster (for example: Retaliators: 4 x Vindicator Massdrivers). Standard units in a campaign may always, if desired, use an Option with a negative TV cost (e.g. a Vindicator equipped with a Retaliator Railgun), but the Player receives no TV bonus for doing so.

The fleet may also purchase weapons and equipment. Weapons and equipment may be freely exchanged between units before battles. Weapons that require Ordnance Counters are reloaded after each battle, assuming the unit survives. If a unit carrying a weapon or piece of equipment is destroyed, that weapon or equipment is also destroyed. Otherwise, weapons and equipment are recovered from any surviving unit and can be used again.

When buying Aces for the Campaign game, they must be assigned to a single vehicle or ship, and may not transfer. If their vehicle is destroyed, they may experience a variety of outcomes (see page 54). When building the fleet, remember that no more than 10% of the fleet's total TV can be spent on Aces and no more than 10% of the fleet's total TV may be spent on add-ons weapons and equipment. A Player may buy as many Options as he wants, but he may not get to use them all at once (see page 73).

A fleet may have as many ships as the admiral wants, but it may only have a limited number of standard units. Each ship has a Vehicle Capacity: this is the number of exo-armors, fighters or exo-suit squads the ship may carry along with it during the campaign. To determine a ship's Vehicle Capacity, look up the ship's class in its fleet list and reference the table next page. Add up the Vehicle Capacities of all the ships in the fleet: this is the fleet's Vehicle Capacity, and is the maximum number of standard units the fleet may have at any time. Note that when choosing forces for the campaign scenarios, there is no limit to the number of standard units that may be fielded; Vehicle Capacity only matters when building fleets and in between battles.

Unless all Players agree otherwise, infantry may not be part of a campaign fleet.

VEHICLE CAPACITY □

Any ship with Vehicle Bays	2/Available Bays
Heavy Ship without Bays	2
Support Ship without Bays	2
Any other ship without Bays	1

Use the table on the Fleet Roster to keep track of your standard units. Any weapons or equipment the fleet possesses should also be recorded here. Use a pencil, since there will likely be lots of changes in your units' conditions and number throughout the campaign. For each ship in your fleet, photocopy an appropriate ship data card and keep it with your Fleet Roster.

SUPPORT SHIPS ◇

Fleets on long missions usually don't get to go home for repairs until after they've finished the job they came out to do. Often, the only way for a fleet to get spare parts, fuel and ammunition is to bring along a group of military support ships. These ships carry Cargo Points that can be spent to repair damaged units. An admiral may take as many or as few support ships as he wishes. Keep in mind, however, that support ships are a fleet's only source of resupply; when they run dry, the fleet will begin to fall apart. Support ships are not an infinite resource. Each support ship has a Cargo Point value listed on its datacard. After choosing the number and type of support ships the fleet will have, note their name and remaining Cargo Points on the Fleet Roster. As Cargo Points are lost or resupplied throughout the campaign, these numbers will change. A fleet may never have more Cargo Points than the total of all its support ships' starting Cargo Point capacities.

Stealing Cargo: It is possible for Close Combat Optimized units to fly up to an enemy transport, grab a crate or two, and run off. A unit must spend one Action in close combat with the support ship; this Action is spent removing the cargo from its moorings. A unit may remove a number of Cargo Points equal to the result of a Skill test roll. The unit may then leave, carrying the stolen cargo as External Cargo (see page 60). Mark the unit with a spare counter. The stolen cargo uses the carrying unit's Avoidance, but has no Protection; if it is hit by any weapon, it is destroyed. If the unit survives the battle, the stolen cargo is automatically added to the fleet's Cargo Point total.

Special Rule for CVNA Fleets: Venusian ships are designed to look like civilian transport ships, enabling them to conceal their identity until the last moment. CVNA Players may purchase Inari and Ebiiru support ships as normal, but the Player should note down (in secret) on each transport's datacard what class of Venusian warship it resembles; on the battlefield, each transport will use its appropriate warship miniature instead of the normal miniature. It is also permissible, for whatever reason, for a Venusian Player to take normal, undisguised support ships. Satrap Transport Carriers count as both warships and support ships. They start a campaign with 50 Cargo Points, and cannot be disguised to look like anything else.

LEADERSHIP ◇

A fleet must have a leader; although the actual rank varies, in this chapter, the term Admiral is used to refer to this individual. In these rules, you, the Player, are the admiral, and are represented in the game by one ship in the fleet that you designate as your flagship. A fleet's flagship is automatically an Ace with a Skill Level of 3, a Skill bonus of 0 and any single Perk; this Ace is free, and does not count against the fleet's limitation on Aces. If the flagship is destroyed, a new flagship must be chosen before the next game is played.

OPTIONAL RULES ◇

When playing a campaign, the baseline set of rules is encompassed by Chapters 2, 6 and 7 in this book. If Players wish to use the rules in Chapters 3 and 4, they may pick and choose which ones will be in effect, and to what extent. For instance, all Players might agree to allow Command Points, and further agree that all Players receive two Tactical Command Points before each battle and that the loser of Initiative receives one Initiative Command Point, regardless of the difference between the initiative rolls. Note the rules' section numbers in the Fleet Roster, so that there's no confusion.



▼ PLAYING THE CAMPAIGN

Now that you've assembled a fleet, allocated supplies and prepared a Fleet Roster, it's time to begin the campaign. Each campaign battle is preceded by a Strategy Phase, in which the scenario to be played is chosen. The battle is followed by the Repair Phase, where the fleet licks its wounds and hopefully receives reinforcements. Campaign Points are also assigned in the Repair Phase.

If there are more than two Players in the campaign, it must be decided which Players will fight each other in the next battle. Each of the campaign scenarios is designed for two opposing sides, so if there is an odd number of Players, one of the Players will either have to ally with another Player and divide up the TV of the battle (reducing both the risk and the potential glory) or will have to skip the session. The exact arrangement of the campaign is left up to the Players; any arrangement will work, so long as everyone has fun.

◇ THE STRATEGY PHASE

In the Strategy Phase, the two Players (for the sake of simplicity, all future references to Players can be assumed to refer to all the Players that make up one side) determine which scenario they will play. They can also spend Cargo Points from the support ships to increase their Fleet Maneuver rating in the hopes of gaining an advantage in the upcoming battle.

Fleet Maneuver: A group of ships is often limited by its slowest members. In Lightning Strike, a ship's thrust and fuel capacity when traveling long distances (such as those between battlefields) are encapsulated in its Fleet Maneuver rating (FMR), which affects how well it does when making Strategy Rolls. On each ship's data card, there is an entry for Fleet Maneuver. A fleet's overall Fleet Maneuver Rating is equal to the lowest FMR in the task force. A ship's Fleet Maneuver rating can be increased temporarily by spending Cargo Points. Each Cargo Point raises one ship's FMR by one. The bonus lasts only until the Strategy Roll is made.

Selecting a Scenario: There are nine scenarios included in this chapter. More will be made available on Dream Pod 9's website (<http://www.dp9.com>) or in future supplements. The Players pick a scenario to play, or they can choose one randomly. If the Players disagree on which scenario to play, the winner of the Strategy Roll (see below) gets to choose. Both Players must pick a scenario *before* the Strategy Roll is made, so that a Player can't change his choice after winning the roll. In order to prevent unscrupulous Players in multi-Player campaigns from teaming up and choosing only the least risky scenarios to play against one another, scenarios should be chosen randomly when there are more than two Players in a campaign.

The Strategy Roll: Both Players make a Skill roll on two dice and add their fleet's current FMR. Apply a -1 penalty if the Player's fleet salvaged from the battlefield at the end of the last battle. Reroll draws.

- 1) The scenario the winner chose before the Strategy Roll was made will be the next scenario played.
- 2) The winner of the Strategy roll may add or subtract 1 from rolls to determine attacker and defender.
- 3) The winner of the Strategy roll may place all Obstacles on the table before either Player sets up his forces.
- 4) In the Initiative Phase of the first turn of the battle, the winner of the Strategy roll may add or subtract up to 3 from his Initiative roll. Subsequent Initiative Phases are carried out normally.

◇ THE BATTLE

The actual strategic movement that the fleets undergo in between battles is totally abstracted. Between a battle, a fleet may cross the Solar System, and months may go by. Thus, it is possible for one battle to be fought in Jupiter's orbit and for the next battle to be fought at the gates of Earth. How the fleets got there is less important than what they do now that they are there.

Each Player chooses a force from his fleet based on the TV allowance defined in the scenario. Note that in these scenarios, there is no limit to the number of standard units that may be fielded; the fleet's Vehicle Capacity does not matter, since the units will simply fly back to their carriers after the battle. Players can assign units to Groups just before the battle starts. After that, fleet list restrictions apply normally.

Options, Aces, weapons or equipment may be assigned at this point. A Player may choose any number of Aces, weapons and equipment from his Fleet Roster; they still cost TV, but the restriction of 10% of the force's total TV does not apply. It is permissible for a Player to choose a few units loaded to the brim with all of the fleet's most expensive equipment; if they get destroyed, though, too bad. No more than 50% of the units chosen for this battle may have Options (see page 72).

The Obstacle Table is used to figure out where the scenario will take place, and the type and number of Obstacles to be found on the battlefield. Roll one die to see which territory the scenario will take place in. Then roll one die for each type of obstacle, modifying the roll by the modifier listed under the appropriate column. The result of each roll is the number of that type of Obstacle that will be on this battlefield. The Player that won the preceding Strategy Roll may place all obstacles on the table before either Player sets up his forces. The Player may choose to place fewer Obstacles, if desired.

Once the Obstacles are placed and the forces set up, the battle begins. Once the scenario is finished, the Players clean up the table and proceed to the Repair Phase.

OBSTACLE TABLE □

Die Roll:	1	2	3-4	5-6
	Jovian Space	Earth Space	Inner Solar System	The Belt
Dust Clouds	+2	0	+1	0
Debris Fields	-1	+1	-1	-1
Rock Fields	-2	-2	-1	+1
Factory Complexes	-1	+1	-1	-4
Asteroids	-2	-2	-1	+2

Special Rules for CVNA Fleets: A CVNA Player always starts each battle with his ships' datacards hidden from his opponent. This is so that the enemy will not know which ships are support ships and which ships are disguised warships. A CVNA ship's datacard is revealed for all to see when it takes any Action that an Ebiiru or Inari is not capable of (such as launching missiles, raising its Avoidance to 3 or using +1 Electronics to defend against a Ping), or if it is hit by an attack (the attack doesn't have to damage; it just has to hit the ship).

THE REPAIR PHASE ◇

The Repair Phase occurs after each campaign battle. It consists of several steps: Salvage, Regrouping, Ship Repair, Standard Unit Repair, Experience, Campaign Points and Reinforcements. The results of the Repair Phase can be kept secret, if all Players agree (and trust each other), in order to add another element of uncertainty to the campaign.

Salvage: If a scenario states that the winner of the battle may salvage, it means that the side that won the fight may attempt to gain Cargo Points from the enemy wreckage left on the field. Each side should keep track of all the units it has lost as the battle progresses. At the end of the battle, the winner may, if he chooses, receive Cargo Points as listed below for each enemy unit that was destroyed on the battlefield. The price for staying around to salvage is that the Player receives a -1 penalty to his next Strategy Roll. Once the decision to attempt to salvage is made, there is no going back; even if the salvage rolls are extremely poor, the Player still has a -1 penalty to his next Strategy Roll. Only units that were on the battlefield when they were destroyed can be salvaged; units and ships that left the table cannot be salvaged.

SALVAGE VALUES □

Ships destroyed by reactor explosions	0 Cargo Points
For each ship destroyed by structural failure or Main-Hull Overkill	Roll 1 die, gain that many Cargo Points
For each non-elite standard unit	1 Cargo Point each
Elite units	0 Cargo Points

Regrouping: After the battle, any survivors will regroup with the main task force. Then, the fleet must take stock of its battle damage. Any ship that left the table with an Overkilled Drive component or Reactor may not be able to make it back to the fleet. Ships that left the table on an "illegal" edge (see individual scenarios for details) may be similarly stranded. For each such ship, roll one die against a Threshold of 3. If the roll fails, the ship is destroyed. If the roll succeeds, the ship manages to regroup with the fleet (although any damage must still be repaired). Ships that suffered reactor explosions, catastrophic structure failure or one-shot Main Hull overkills are destroyed.

If a fleet loses too many warships, it may not have enough room to carry all its exo-armors, fighters and exo-suits to the next battle. If the number of surviving standard units exceeds the total Vehicle Capacity of the fleet's remaining ships, a number of standard units must be left behind and are considered destroyed. Each such unit may be converted into one Cargo Point, assuming there's room in the transports.



Survival: Many units that are "destroyed" in combat are actually in pretty good shape. Very seldom is the unit so battered that it can't be fixed, and pilots often safely eject. After every battle, roll a die for every destroyed standard unit (with the exception of anything that was at ground zero of a ship reactor overload, which is absolutely, positively vaporized). If the unit was crewed by an Ace, add +1 to the die roll.

☐ STANDARD UNIT SURVIVAL DIE ROLL EFFECT

1-4	The unit is completely destroyed. Any weapons, equipment or Options it had are destroyed.
5	The unit is Crippled, and must be repaired. Weapons, equipment and Options are unharmed.
6	The vehicle is unharmed (the damage was an easy-to-repair critical hit).

A fleet is assumed to have an effectively unlimited supply of standard pilots and crews (one may assume that such individuals can be picked up between battles relatively easily). Aces, however, are harder to come by. If an Ace's vehicle is destroyed on the battlefield, roll a single die for the Ace himself, as well as for his vehicle.

☐ ACE SURVIVAL DIE ROLL EFFECT

1	The Ace has been killed or is too severely injured to fight anymore. Remove the Ace from the fleet roster. If the Ace's vehicle survived, it may be sent into battle with a standard pilot or a replacement Ace.
2	The Ace has been captured by the enemy. The opponent may execute the Ace, give him back for free, ransom the Ace in exchange for the Ace's TV worth of Cargo, equipment or vehicles, or simply keep the Ace until he decides what to do with him.
3-4	The Ace is injured, and may not be used for two battles. After the fleet has fought two battles, the Ace has healed. The Ace may be assigned to a new vehicle as described below if his original vehicle is destroyed.
5-6	The Ace is unharmed, and may be assigned back to his vehicle (if it survived; see above) or another vehicle of exactly the same type (i.e. a Wyvern Ace must pilot a Wyvern). If no suitable vehicle is available, the Ace must sit out until one becomes available by reinforcement (he could pilot another unit as a standard pilot, but there is no benefit to this, since a fleet has unlimited standard pilots, anyway).

Ship Repair: Most repairs that take place on the battlefield are jury-rigs that tend to fall apart within a matter of hours. After a battle, more permanent repairs must be undertaken. For ships, all marked-off damage boxes may be erased (destroyed or stolen Cargo Points, however, are lost forever), but Overkilled systems remain Overkilled, and must be repaired separately. If the ship received any damage at all in the battle, even if it was subsequently repaired, the Player must now pay a number of Cargo Points equal to the ship's Repair Value (listed on its datacard). If the Player does not have enough Cargo Points to pay this cost for a ship, one random item (use the ship hit location chart) is Overkilled; the jury-rigged repairs fail, causing massive secondary damage, but the rest of the ship holds together.

Each Overkilled ship system costs the ship's Repair Value in Cargo Points to repair. Once repaired, the system is fully functional. Destroyed Cargo sections may be repaired, but the destroyed Cargo Points are gone forever. The only benefit to repairing Cargo sections is if the fleet needs more Cargo space to store salvage and reinforcement Cargo Points later on. If an Overkilled system is not repaired, the ship will carry the damage with it from battle to battle until it can be repaired.

Standard Unit Repair: Stunned standard units are automatically un-Stunned. After checking the disposition of all destroyed standard units (see Regrouping, above), the Player may repair any standard units that are still Crippled. The Standard Unit Repair Cost from the table below is the number of Cargo Points needed to return a Crippled standard unit to full functionality. The maximum number of standard units that can be repaired is equal to the number of Bays the fleet has. Overkilled Hangar sections not count toward this number, nor do Bays on ships such as the Intrepid (whose datacard states that its Bays may not repair units).

☐ STANDARD UNIT REPAIR COSTS

Command Units	3 Cargo Points
Special-duty Units	3 Cargo Points
Elite Units	4 Cargo Points
All other units	2 Cargo Points
Standard units that are not repaired will remain Crippled until they are repaired.	

Experience: Every ship that participated in and survived the preceding battle gains one Ship Experience Point, which should be noted on its datacard. For every two standard units that participated in and survived the preceding battle, the fleet gains one Standard Unit Experience Point. Lightning striking units (see page 46) do not receive any Experience. Experience Points can be used to upgrade ship and vehicle crews to Aces. Note that the "10%" restriction on Aces only applies when first building the fleet before the campaign begins; it is permissible for a fleet to have more than 10% of its TV represented in Aces as a result of gaining new Aces through experience or reinforcements (see below). Units that become Aces via experience have a minimum Skill Level of 2, and may be upgraded repeatedly to gain higher Skill Levels, Skill Bonuses and Perks; simply pay the TV difference between the current level and the desired new level.



Ship Experience Points can be traded in to upgrade a ship's crew to an Ace ship crew. Treat each Ship Experience Point as a five TV points usable only to pay the Ace costs for that ship. Standard Unit Experience Points can be traded in to upgrade standard units to Ace units. Treat each Standard Unit Experience Point as one TV point usable only to purchase new Aces. The Aces can be assigned to any standard unit, so long as enough Experience Points are spent to pay for the unit's Vehicle Modifier (see page 40).

Note that Ships that start the campaign as Aces do not receive experience, and standard units that start the campaign as Aces may not be upgraded using Standard Unit Experience Points (although they still count for gaining Standard Unit Experience Points).

Campaign Points: Campaign Points are a measure of your fame (or infamy) as a fleet admiral. You gain Campaign Points for victories and kills, and lose them for defeats and unit losses. Keep a running total of your Campaign Points on the Fleet Roster. At the end of the campaign, the Player with the most Campaign Points wins.

CAMPAIGN POINTS □

Complete victory won	+3 Campaign Points
Marginal victory won	+1 Campaign Point
Battle lost	-2 Campaign Points
Flagship participates in a battle	+1 Campaign Point
Flagship destroyed	-10 Campaign Points (to a minimum of zero)
For each Ace (not counting flagship) that participated and whose vehicle was not destroyed	+1 Campaign Point
Ace killed or captured	-1 Campaign Point

Reinforcements: Depending on how well the fleet is doing, and how much it is in need, reinforcements may sometimes be diverted to aid the fleet. To request reinforcements, roll one die against a Threshold of 4. For every five Campaign Points your fleet has, add one to this roll. If the roll fumbles or fails, you get nothing. If the roll succeeds, you will receive reinforcements.

If you receive reinforcements, roll one die on the following table, and subtract one from the result for every five Campaign Points your fleet has. You may roll a number of times equal to the Margin of Success of the request roll. For each roll, you may select one of the reinforcement options from the table below that the result of the die roll allows. The reinforcements arrive immediately and may be used in the next battle.

REINFORCEMENT DIE ROLL RESULTS □

Any result	20 Cargo Points
2 or greater	30 TV worth of non-Elite standard units or weapons/equipment
3 or greater	100 TV worth of ships
4 or greater	50 TV worth of standard units (maximum of 1 Elite unit)
5 or greater	150 TV worth of ships
6	Up to 4 new Aces, maximum total cost 30 TV

ENDING A CAMPAIGN ◇

If, at any time, a fleet has no ships left, it is considered wiped out. Its exo-armors, fighters and exo-suit squads have no way to get home or to travel any significant distance, and will soon die in the cold void of space. Otherwise, a campaign ends when all Players have played the agreed-upon number of games, or when everyone agrees to stop. Each fleet may keep its accumulated Campaign Points for the next campaign.



scenario 1

◇ KNOCK, KNOCK

Gathering intelligence is the first step to winning any battle. Waiting for your enemy to gather intelligence and then smacking him across the face is the best way to trip someone who's trying to take a first step.

Attacker/Defender: Each player rolls two dice. The winner of the Strategy roll may add or subtract one from his roll. The winner of the roll chooses which player will be the attacker.

Force Composition: the defender's force consists of as much of his fleet as he desires. The attacker may choose a force up to 20% of his fleet's total TV, or up to 75 TV, whichever is greater.

Setup: the defender sets up his entire force no greater than 20 cm from the center of the table. The attacker may set up his force no further than 10 cm from any one table edge. The battle lasts until the attacker is either completely destroyed or has retreated off the table.

Special Rules: the defender keeps his ship data cards hidden from the attacker. Only when one of his ships takes an Action or is successfully attacked must that ship's data card be revealed. The defender may not retreat any ships or standard units off the table.

Attacker Objective: For each unit in your force, you must reveal one enemy ship datacard (or, if there aren't enough enemy ships, all enemy datacards), or you lose. If you do this and at least half your force survives, you win a complete victory. Otherwise, you win a marginal victory.

Defender Objective: If the attacker wins completely, you lose. If the attacker wins marginally, you also win a marginal victory. No matter the outcome, you may Salvage.

scenario 2

◇ VAMP

Before we begin, sir, I should ask: do you know what a trapdoor spider is? No? It's something they have on Earth. Well, when you're done with this little outing, you'll have good reason to go look it up.

Attacker/Defender: Each player rolls two dice. The winner of the Strategy roll may add or subtract one from his roll. The winner of the roll chooses which player will be the attacker.

Force Composition: the defender may choose a force up to 30% of his fleet's total TV, or up to 75 TV, whichever is greater. The attacker may choose a force up to 20% of his fleet's total TV, or up to 50 TV, whichever is greater.

Setup: there must be at least ten Obstacles on the table. If an insufficient number of Obstacles is randomly generated, add enough Obstacles of your choice to make up the difference. The defender sets up his entire force no greater than 20 cm from any one table edge of his choice. The attacker does not set up as normal. Instead, at the end of each turn's End Phase, he may place any portion of his force on the table inside one or more of the Obstacles.

Special Rules: the defender may not use Overthrust, Aiming or Evasive counters in the first two turns. The defender may not use lightning strikes at all. To escape the battle, the defender's units must leave the table on the edge opposite from its starting edge. The attacker's units may leave the table from any edge.

Attacker/Defender Objective: the battle lasts until one side is either completely destroyed or has retreated off the table. The side that remains in control of the table may Salvage. The attacker must destroy at least half of the enemy force's TV. If he succeeds, he completely wins the scenario. If he fails, he loses.

scenario 3

◇ VANDALISM

If your enemy is huddled into a corner, don't go right for the throat. Cornered enemies are dangerous. Instead, walk up and kick him in the shins. Keep doing it, and sooner or later he'll come out to play on your terms.

Attacker/Defender: Each player rolls two dice. The winner of the Strategy roll may add or subtract one from his roll. The winner of the roll chooses which player will be the attacker.

Force Composition: the defender may choose a force up to and including his entire fleet. The attacker may choose a force up to 15% of his fleet's total TV, or up to 75 TV, whichever is greater.

Setup: the defender sets up his entire force no more than 20 cm from the table's center. The attacker sets up his entire force no greater than 10 cm from any one table edge of his choice.

Special Rules: none of the defender's warships may move until the fifth turn. Either player's forces may leave the table from any edge. The attacker must nominate a single enemy warship at the start of the first turn. If the defender has no warships, the attacker must choose a single Ace or four specific standard units; the Ace or units may not leave the table for any reason. The battle lasts until one side is either completely destroyed or has retreated off the table; the side left controlling the table may Salvage.

Attacker Objective: Destroy the unit you nominated at the beginning of the scenario; if you retain more than half of your starting TV, you win a complete victory, while if you lose half or more of your starting TV, you win a marginal victory.

Defender Objective: If the attacker wins completely, you lose completely. If the attacker wins marginally, you win marginally.

NOBODY HOME ◇

The lone soldier is not alone so long as two assumptions hold true. The first is that he can shout to his friends for help. The second is that his friends aren't sleeping on the job.

Attacker/Defender: Each player rolls two dice. The winner of the Strategy roll may add or subtract one from his roll. The winner of the roll chooses which player will be the attacker.

Force Composition: the defender may choose a force up to 30% of his fleet's total TV, or up to 75 TV, whichever is greater. The attacker may choose a force up to 15% of his fleet's total TV, or up to 40 TV, whichever is greater.

Setup: the defender sets up 20% of his chosen force anywhere on the table. Before the attacker sets up, the defender must openly choose one table edge. This edge is his entry point. At the end of each turn's End Phase, he may place up to 10% of his unused forces no more than 10 cm from his entry point. If the defender desires, he may delay this entry until a later turn, and thus bring a larger force onto the table in a single turn. The attacker sets up his entire force no greater than 10 cm from any one table edge of his choice, except for the defender's entry point.

Special Rules: The attacker's units may only leave the table from their entry edge. The defender's units may not leave the table from the attacker's entry edge.

Victory: the battle lasts until one side is either completely destroyed or has retreated off the table. In the End Phase of each turn, if the defender has no forces on the table, he may choose to concede the battle. The side that controls the table at the end of the battle is the winner, and may Salvage.

scenario 4

HEADHUNTER ◇

You did what? Well, I sure hope you've got a plan for this one. Don't worry, it happens to a lot of people. That won't stop the other candidates from laughing at you, though. Rightly so, too.

Attacker/Defender: the winner of the Strategy Roll is the attacker in this scenario.

Force Composition: the defender gets his flagship and up to eight standard units; this makes up the Flagship Force. In addition, the defender may choose a force up to 20% of his fleet's total TV, or up to 60 TV, whichever is greater.

The attacker may choose a force up to 15% of his fleet's total TV, or up to 45 TV, whichever is greater.

Setup: the defender sets up the Flagship Force no further than 20 cm from the table's center. Before the attacker sets up, the defender must openly choose one table edge. This edge is his entry point. At the end of each turn's End Phase, he may place up to 20% of his unused forces no more than 10 cm from his entry point. If the defender desires, he may delay this entry until a later turn, and thus bring a larger force onto the table in a single turn. The attacker sets up his entire force no greater than 10 cm from any one table edge of his choice, except for the defender's entry point.

Special Rules: The attacker's units may not leave the table from the defender's entry point. The defender's units may leave from any edge. The defender's flagship may not move on the first turn. The scenario ends when the flagship or all attackers are removed from the table.

Attacker Objective: Destroy the enemy flagship for a complete victory. Any other result is a loss.

Defender Objective: If you your flagship survives and you drive off the enemy, you win a complete victory, and may Salvage. If your flagship retreats from the table, you win a marginal victory.

scenario 5

FACE OF THE ENEMY ◇

When you're groping in the dark for your enemy, sometimes you get lucky and find his throat. Then again, sometimes you end up with an earlobe. Don't feel cheated, sir. Just bite really hard.

Force Composition: each player may choose a force up to 30% of his fleet's total TV, or up to 75 TV, whichever is greater.

Setup: the players set up at opposite sides of the table, within 20 cm of the edge.

Special Rules: to escape the battle, a unit must leave the table on the edge opposite from its starting edge.

Attacker/Defender Objective: the battle lasts until one side is either completely destroyed or has retreated off the table. The side that remains in control of the table wins a complete victory, and may Salvage. The other side loses.

scenario 6



scenario 7

◇ OUTNUMBERED

There are lots of ways you can get surrounded. Some of them may not even be your fault, although none come to mind at the moment. If you can't figure out how to break out, then it's always your fault.

Attacker/Defender: the player who won the Strategy Roll is the attacker in this scenario.

Force Composition: the defender may choose a force up to 20% of his fleet's total TV, or up to 75 TV, whichever is greater. The attacker may choose a force up to 60% of his fleet's total TV, or up to 200 TV, whichever is greater.

Setup: the defender sets up his entire force no greater than 20 cm from the center of the table. The attacker may set up his force no further than 10 cm from any or all of the table edges.

Special Rules: at the start of the battle's first turn, the defender must openly choose one table edge and his escape route; the defender may only leave the table from this edge. The attacker may leave the table from any edge. The battle lasts until one side is either completely destroyed or has retreated off the table; the side left in control of the table may Salvage.

Attacker/Defender Objective: each player adds up the TV he lost during the battle. The defender divides this number by two. The player whose result is the lowest wins a complete victory. If the result is a draw, both players win marginal victories.

scenario 8

◇ BACK SHOT

The second greatest danger in sending out a strike force to hit the enemy where he's vulnerable is that your enemy will send out a strike force to hit you where you're vulnerable. The greatest danger, of course, is that he'll find you first.

Attacker/Defender: the player who won the Strategy Roll is the attacker in this scenario.

Force Composition: the defender must take all of his support ships. In addition, he may choose a force up to 20% of his fleet's total TV, or up to 100 TV, whichever is greater. The attacker may choose a force up to 15% of his fleet's total TV, or up to 75 TV, whichever is greater.

Setup: the defender sets up his support ships and 20% of his chosen force no more than 20 cm from the table's center. Before the attacker sets up, the defender must openly choose one table edge as his entry point. The attacker sets up his entire force no greater than 10 cm from any or all table edges of his choice, except for the defender's entry point.

Special Rules: none of the defender's ships may move in the first turn. At the end of each turn's End Phase, he may place one ship or up to four standard units no more than 10 cm from his entry point. If the defender desires, he may delay a ship or standard unit's entry until a later turn, and thus bring a larger force onto the table in a single turn.

The defender's forces may only leave the table from the defender's entry point. The attacker's forces may not leave the table from the defender's entry point. The battle lasts until one side is either completely destroyed or has retreated off the table; neither side may Salvage.

Attacker Objective: kill the defender's support ships. If you destroy them all, you win completely. If you destroy none, you lose. Anything in between is a marginal victory.

Defender Objective: save your support ships. If all the support ships survive, you win completely. If all the support ships are destroyed, you lose. Anything in between is a marginal victory.

scenario 9

◇ FULL CONTACT

All right, sir. Lights on, gloves off. It's a stand-up fight, just the sort of thing you're supposed to avoid. You're nervous, worried, anxious and, if your performance up to this point is any sign, you're probably going to lose. The only consolation I can offer is that your opponent is in the same boat. Bon chance: you'll need it.

Force Composition: each Player's force consists of his entire fleet.

Setup: the Players set up at opposite sides of the table, within 20 cm of the edge.

Special Rules: to escape the battle, a unit must leave the table on the edge opposite from its starting edge.

Victory: the battle lasts until one side is either completely destroyed or has retreated off the table. The side that remains in control of the table wins a complete victory, and may Salvage. The other side loses.



▶ PERKS AND FLAWS

Most units have one or more Perks or Flaws, which help to distinguish the units and modify their effectiveness in certain situations. Perks are good, and Flaws are bad. Perks or Flaws with a number inside parentheses are referred to as having a **Rating**. A rating is a numerical representation of the characteristic's effectiveness.

▼ BASIC PERKS AND FLAWS

Concealed Sections: some ships have components that can be withdrawn into the Main Hull for protection. This is designated by the Con notation on the datacard, along with a rating. In order for Concealed systems to be used (the Narwhal's railguns and antenna array, and the Detroit's damage control and repair abilities), the ship must spend a number of Actions equal to the rating to deploy these components. When concealed, the systems use the main hull's Protection value. When deployed, they use their own Protection values. If the ship does not have enough Actions in a turn to fully deploy or conceal its components, it may spread the action requirement over several turns.

Energy/Projectile Protection (#/#/#): the unit's armor or structure is particularly resistant to a particular type of damage. Instead of a rating, this Perk has a full set of Protection values next to its notation on the Datacard. When attacked by the appropriate type of weapon, use the listed protection instead of normal protection.

Exposed Fire Control: the unit has a poorly-protected targeting system. On 'Crippled' combat results, all range bands other than 'C' on all attacks are destroyed. The unit may now only attack in close combat.

Missile Defense (#): the unit is equipped with a protective measure (such as a computer-controlled decoy launcher) that helps the unit to avoid being hit by attacks with the "Missile" characteristic. Add the rating to all Defense Rolls against these attacks. It is possible for this number to be negative. Missile Defense also works against attacks with the S-Mis characteristic.

Multiple Redundancy: this Perk represents either massive backup systems or a large number of individual units (such as a squad of exo-suits). On a successful Piloting roll vs. a threshold equal to the rating, the unit may ignore the effects of any damage result, be it a Stun, Cripple or Overkill. This roll should be made immediately after the damage is inflicted; if successful, no damage counter is placed on the unit. This Perk may be used for every damaging hit upon the unit.

Reinforced Systems (#): on a successful Piloting roll vs. a threshold equal to the rating, the unit may ignore the effects of a 'Crippled' damage result. This roll should be made immediately after damage of the appropriate level is inflicted (a Crippling hit or a second Stunning hit); if successful, no Crippled counter is placed on the unit. This Perk may be used once each time Crippling damage is inflicted on the unit. It has no effect on hits that only cause Stun damage.

Target Designator System (#): the unit gains the rating as a bonus to all of its Tagging rolls (see page 72).

Venusian: This Perk is used to distinguish the special qualities of Venusian ships. When using the Spoof action, Venusian ships roll against a Threshold of 2. When using the Damage Control action, Venusian ships roll against a Threshold of 5. Under normal movement (i.e., applying thrust without spending an action), Venusian ships do not lose Avoidance; only if an action is used in order to gain extra thrust in a turn does a Venusian ship's Avoidance drop (by one point).

▼ CARGO

Some units are equipped to transport cargo that is clipped, strapped or in some way attached to their outer hull. The type(s) or cargo a unit is allowed to carry is specified on its Datacard. A cargo-carrying unit may move and act normally when it is carrying cargo; it simply carries its cargo with it wherever it goes (place the two counters in contact with one another). For targeting purposes, units that are docked in this fashion are considered to be Grappling (see page 36). For simplicity's sake, assume that the carried unit always faces in the same direction as the carrying unit.

If the cargo is another combat unit, like an exo-armor or exo-suit squad, that unit may take its action normally during a turn. The cargo may not move, evade or aim on its own, and its actions are also subject to any movement-related restrictions that the carrying unit takes (i.e. Overthrust, Evasion and Aiming). In close combat, treat the carrying unit and its cargo as two separate units; they can both fight, and count toward multiple attacker bonuses. However, since the carrying unit and its cargo are stuck to one another, they both suffer a -1 penalty to their Close Combat Optimized Perk (if this Perk is not present, then there is no effect).

A unit may release its cargo at any point in its action phase, at the cost of one action. If the cargo is mobile (i.e. is capable of taking its own actions, like an exo-armor or exo-suit squad), it may move and act normally after being dropped, assuming it hasn't already used its action phase for the turn. In addition, mobile cargo may disengage itself at the cost of one action (and no cost to the carrying unit). Finally, mobile cargo may dock with a suitable cargo-carrying unit if both units spend one action.

The Internal Cargo perk is similar to the External Cargo perk, except that the cargo is enclosed and sheltered by the carrying unit's hull. As a result, the cargo may not make any attacks, take any actions, nor fight in close combat. The cargo may not be attacked while being carried. If the carrying unit (or the cargo-carrying component thereof) is destroyed, then the cargo takes damage equal to half that of the initial attack. If the cargo survives, it is now floating free and acts as an independent unit

CLOAK ▼

There are few more complex, expensive and dreaded pieces of battlefield equipment than the suite of computers, photoskin coverings, sensor-damping devices and advanced propulsion systems that is collectively known as a **Cloak**. Although Cloaks have been installed to great effect on prototype vehicles like the infamous Typhon, the only production units even suspected of possessing a Cloak are the Venusian G-8 Korikaze exo-armor and the Huang-ti Observer Ship.



B.1.1.3

A Cloaked unit gains the following benefits for an entire turn, so long as it is not Crippled, by spending one Action. Place a Cloak counter next to the unit; if it does not move more than its normal move distance or take any other actions, it is considered invisible, and may not be directly fired on or attacked in close combat. If a cloaked unit takes an Action of any kind (aside from cloaking), it is immediately uncloaked. Any ship missiles locked on to a cloaked unit lose their lock. The missiles will still travel to the target area, but if the target is still successfully cloaked in the End Phase, the missiles are unable to find their target and automatically self-destruct, causing no damage.

A unit may attempt to target the cloaked unit by spending one action while within 10 cm of the cloaked unit. An opposed Skill test is made: the attacker adds his Electronics rating, the defender adds his Cloak rating. If the defender is successfully targeted, then all enemy units are able to target it, and the cloak is immediately negated. A Group of units may combine attempts to see through a cloak, just like an attack (see page 26).

DEEP CLOAK ◇

When a unit cloaks itself, its enemies usually have an idea of its general location. If, however, the cloaked unit remains concealed long enough to drift a significant distance, it will be able to completely elude detection. Such a state is called **Deep Cloak**.

If a unit begins its action phase already cloaked, and there are no enemy units within 10 cm, that unit may spend another action to go into deep cloak. Remove the unit from the table, leaving only the Cloak counter to mark the unit's last known position. No further attempts to target the unit may be made.

A unit in deep cloak may not take any actions, except to remove Stun counters. When its Group's action phase comes up, it can attempt to remain in deep cloak. To do so, the unit must pass a Skill test against a Threshold of 3. If the test is passed, the unit remains invisible. If the test is failed, the pilot has made an error in managing the photoskin. The unit must immediately be placed back on the table (see below).

Every turn that a unit spends in deep cloak, it may "move" further away from its last known position. This deep-cloak movement rate is equal to the unit's normal movement rate. When a deep-cloaked unit decides to reappear, multiply the unit's normal movement rate by the number of turns the unit has been in deep cloak: this number is the maximum number of centimeters the unit may be placed from its Cloak counter. Other than this restriction, the unit may appear anywhere on the table.

Keep track of the number of turns a unit remains deep-cloaked by placing a die with the "1" showing next to the Cloak counter the first time the unit passes its Skill test. Each successive turn, increment the number on the die by one. When the unit decloaks, simply multiply its normal movement rate by the die's number.

If a unit in deep cloak chooses not to remain cloaked, it is placed back on the table at the beginning of its action phase. It may then move and act as normal. If, on the other hand, a unit drops out of cloak as a result of failing its deep-cloak Skill test, it may not move, act, Overthrust or Evade until its next action phase (the pilot still thinks he is invisible).

6.3.4



▼ CLOSE COMBAT OPTIMIZED (#)

In close combat ('C' range), this unit adds the rating of this Perk to its attack and Defense Rolls when fighting units without this characteristic. If both the attacker and the target have this Perk, use the difference between the two ratings (if any) as the attack and defense bonus for the unit with the higher Close Combat Optimized rating. Thus, if a Pathfinder (CCO rating 2) is in close combat with a Syreen (CCO rating 1), the Pathfinder will get a +1 bonus to all its rolls against the Syreen because it is better equipped for hand-to-hand combat.

A Close Combat Optimized unit cannot be attacked from behind in close combat unless there is more than one attacker. It may always turn itself to face an incoming *close combat* attack; however, it must keep its new facing even after the attack ends, and it may not turn in this manner if there is currently an enemy in base-to-base contact with it.

Units with this perk may latch onto a ship's hull, thus moving where the ship moves, like a parasite. This is called **Clamping**. A clamped unit may unclamp from the ship and go its own way again at any time. Clamping and unclamping cost no Actions and take no time; the only requirement is that the unit be in physical contact with the ship's centerpoint (or as close to as possible).

Clamping can be a very powerful tool for units, since it essentially allows a unit to get 'free' movement. A unit that begins the turn in close combat with a ship may clamp onto it in the first ship phase and be carried along with the ship when moves, then unclamp in the main phase and continue on its merry way. Alternatively, a unit may stay clamped to a ship turn after turn, attacking the ship in close combat from where the ship cannot get at it. A clamped unit may attack the ship in close combat as normal; the ship gets to roll its normal defense. (See Expanded Close Combat, page 36)

▼ ELECTRONIC WARFARE (#)



6.3.5

Some units are equipped with complex suites of electronics allowing them to interfere with their enemies' communications and sensors. These Electronic Counter Measures (ECM) systems consist of jammers, white noise generators and other devices that can only be effectively canceled out by dedicated ECCM (Electronic Counter Counter Measures) systems. Units equipped with ECM and ECCM are marked as such on their datacards.

It costs one Action to activate ECM, and one Action every turn thereafter to maintain the ECM. A Skill roll is made, and the rating of the unit's ECM is added to the result (if the unit is subject to an Overthrust penalty, it applies as well). This is the ECM's threshold. Place an ECM counter marked with the threshold on the unit (if a high enough threshold counter is unavailable, use a combination of counters adding up to the current threshold). Enemy communications are now jammed, and no units or ships on that side may use Command Points (see section 4.1, page 40). ECM has, for the purposes of the game, unlimited range. ECM does not affect Command Point usage for friendly units or ships.

Maintaining ECM costs an Action, but does not require any additional Skill rolls. An ECM unit may, however, choose to reroll its ECM in order to get a better threshold. If the unit cannot pay an Action to maintain its ECM (if, for instance, it is Stunned and wishes to remove the Stun counter), the ECM counter is removed at the end of its Action phase, and enemy communications return to normal. If a unit that is activating or maintaining ECM is Crippled, its ECM counter is removed, and it may no longer use ECM. If an ECM-using unit is destroyed, the ECM counter is removed immediately.

If several units on the same side use ECM at the same time, only the highest ECM threshold gets a counter on the playing field to represent it. All weaker ECM thresholds from that side are canceled out. If, later on, a friendly unit activates ECM and gets a higher threshold than the current one, the owning Player may remove the old ECM counter and place an ECM counter on the new 'high' unit.

Instead of using ECM to create broad-based communications disruption, an electronics-warfare unit can also attempt to interfere with a single target on a deeper level, causing failures in targeting and unit-identification systems. ECM can also help a friendly unit by masking its location with radiation and false sensor traces. This is called **Targeted ECM**.

To use **Targeted ECM**, each Player must have an extra set of ECM counters, marked so as to be different from normal ECM counters and the other Players' ECM counters. By spending one action, the ECM-using unit may nominate a single target (including itself). The range is limited by the unit's Electronics rating as listed on the Tagging Range Table (see page 72).

An opposed skill roll is made. Both units add their Electronics rating; the attacker also adds its ECM rating, and the target may add its ECCM rating, if desired. The target may decline to roll, using zero as its result. If the attacker wins, the ECM attempt is effective. Instead of placing the ECM counter next to the ECM-using unit, place the counter next to the unit being affected.

If the target is friendly, it gains a +2 bonus to its Avoidance and to any rolls to resist being locked-on, tagged or designated, while the Targeted ECM counter is in play.

If the target is an enemy, it receives a -2 penalty to its attack rolls and any attempts to lock-on. In addition, the target's identify friend or foe (IFF) system is disabled, making it vulnerable to its own side's minefields, and the target may not tag, target designate, use ECM or spend Command Points. These effects last as long as the Targeted ECM counter is in play. Although a side can only have one normal-type ECM counter on the table at any time, any number of Targeted ECM counters may be present at any time.

Targeted ECM effects are not cumulative; adding more targeted-ECM counters to a victim only means that each counter must be removed individually before the effects of the ECM are lifted. At the end of each End Phase, every unit with targeted-ECM counters on it makes a skill roll against a threshold of 4 for each ECM counter (friendly or hostile) it has on it; if the roll succeeds, remove the counter. A unit with ECCM may spend an action to remove an enemy ECM counter on it without having to roll, but is unable to use ECCM to help other units.

It is possible to occasionally get a transmission through an ECM blockade, simply by luck or stubborn persistence. If a Player wishes to break through the ECM and give a Command Point to a unit that is being jammed by ECM, the unit must make a Skill roll, modified only by its Electronics rating (usually zero). If the roll beats the ECM threshold, the unit may use the Command Point; otherwise, the roll fails and the Command Point is lost. Either way, the ECM threshold remains in place.

ELECTRONIC COUNTER COUNTER MEASURES ◇

Units with ECCM can use it to dispel the effects of hostile ECM. For each Action spent on ECCM, a Skill roll is made, and the unit's ECCM rating is added to the result. If the total is higher than the ECM threshold, the ECM counter is removed, and communications are restored. If the total is lower than the threshold, the attempt fails and the ECM counter remains. If the roll ties the ECM threshold, the ECM threshold is halved (rounding down), but continues to block communications. The ECM counter should be changed to reflect this. Crippled units may not use ECCM.

STEALTH ▼

Stealth is used to define vehicles that are designed with shielded exhausts, radar-absorbing hulls, and other sensor-defeating measures of a passive nature. Stealth components are effective but fragile; even slight damage can negate their effectiveness. A Stealthy unit gains the following benefits at all times, so long as it is not Crippled:

- 1) A Stealthy unit gains a bonus to its Avoidance equal to its Stealth rating.
- 2) When rolling to defend against lock-ons from ship missiles and tagging, a Stealthy unit may add its Stealth rating to the roll.
- 3) A unit attempting to target a specific component of a Stealthy ship reduces its Electronics rating by the ship's Stealth rating for the purposes of targeting only.
- 4) Units with Stealth are always the last units to be placed on the battlefield. If there are units with Stealth on both sides, take turns placing Stealthed units according to their Stealth Rating, starting with Stealth level 1, and proceeding up through increasingly more stealthy units until all Stealthed units are placed.

Stealth systems are very fragile. If a Stealthy unit is Crippled, all benefits of Stealth are immediately and permanently lost. Stealthed ships lose their stealth permanently the first time their Main Hull is damaged.

B.1.5



▶ WEAPONS AND CHARACTERISTICS

Many attacks have various Characteristics built into them, noted on the Datacards under the 'Notes' column. These characteristics confer certain abilities above and beyond the basic attack stats, making them more versatile or setting limits upon their operation. The abbreviation in parentheses that follows each characteristic name is the way that characteristic is listed on the unit Datacards, and the numbers that follow the abbreviation are the characteristic's rating.

▼ BASIC WEAPON CHARACTERISTICS

Anti-Infantry (AI#): the attack is especially effective against small units. It gains the listed Accuracy bonus to any attacks against exo-suits or infantry. Unless otherwise noted, all exo-suit and infantry attacks automatically have this characteristic at a rating of 2.

Anti-Ship (AS#): the attack is designed to do massive damage to large targets. It gains the listed Accuracy bonus to any attacks against any object of Size 6 or larger (this includes all warships in this rulebook).

Armor-Destroying (AD): an Armor-Destroying weapon is massively destructive, such that all modern defenses are practically useless against it. Such weapons have the benefits of the Armor Piercing characteristic (i.e. the target's Protection rating is halved), but are, unlike normal Armor Piercing weapons, allowed to inflict Overkill damage.

Armor Piercing (AP): the attack is especially good at penetrating a target's defenses. The target's Protection ratings are all halved, rounding up. However, the attack may not Overkill any target; the maximum possible hit result is Crippled.

Energy Homing (EH): the weapon gains a +3 attack roll bonus if the target is using standard ECM. If the Reaction Attack rule is in use (see page 34), the weapon may also be used to Reaction Attack a unit immediately after that unit rolls to Ping, Tag or to use ECCM or targeted ECM.

Flak (Fl): when attacking ships, the weapon's maximum possible damage is Stun damage.

Haywire (H): If the weapon inflicts Stun damage on a ship component, that ship's Electronics receive a point of damage. If the weapon inflicts Crippling damage, the target's Electronics receive two points of damage. If the weapon hits an exo-armor or other standard unit, any damage inflicted is automatically one level worse (i.e. Stun damage becomes Crippling damage, and Crippling damage is Overkill).

Missile (Mis): the attack consists of a self-guided munition that moves through space under its own power and guidance. There is no inherent benefit to this characteristic. However, some defensive systems are specifically designed to shoot down incoming missiles.

Power-Hungry (PH#): found on warships only. The weapon requires a great deal of power and attention to fire. The rating is the number of weapons other than the power-hungry weapon that may be fired in one Action. For instance, a weapon with PH0, if fired, would not allow any other weapons to be fired in that Action. Standard-mode PDS would still get an opportunity to fire, however, and warship missile bays would still be able to operate normally.

Rapid Fire (R#): this weapon may make a number of additional attacks equal to the rating at no additional Action or defensive cost; the entire series of attack rolls is considered a single Action and a single attack. Thus, a weapon with R2 could make three attack rolls for each Action spent (one normal attack, followed by the maximum of two additional attacks). Rapid Fire may be used on multiple targets, but only if all the targets are within the weapon's firing arc.

Ship Missiles: these complex weapons require rules of their own. See 6.2.2 on next page.

Slow (Slw#): the attack must be used under very steady conditions. The attacking unit may only use this attack if it is Aiming (see page 34).

Seek (Sk#): this weapon can auto-correct its course and aim. The number after the 'Sk' is the number of extra dice that may be added to the attack roll. For example, a standard (Skill Level 2) pilot fires a 'Sk2' weapon. The attack roll, before any other modifiers, is four dice (two dice for the pilot's Skill plus two dice for the Seeking characteristic of the weapon itself).

2-9

6-2-1

Self-destruction (SD): generally not found on manned vehicles, this weapon characteristic has one, very simple effect: whenever the weapon is used to make an attack, the entire firing vehicle is immediately destroyed, regardless of whether or not the target is destroyed (or even hit). This characteristic is most often used to define cruise-missile-type vehicles, designed to blow up once they reach their destination.

Stealthy (St): attacking with this weapon does not alter the firing ship's Avoidance.

Sweeping (Swp#): The weapon may "sweep" its beam across a wide area, increasing its chance to hit, but reducing its overall damage. Whenever the weapon fires, it may reduce its Damage by the Perk's Rating in exchange for a +1 bonus to Accuracy. This exchange may be taken any number of times, so long as the weapon has damage left to "spend."

Target Designator (TD): A weapon that is a target designator does no damage when it hits. Instead, the target's Avoidance is lowered by the Margin of Success of the attack. If the target is a standard unit, mark it with a Designation counter; its Avoidance is lowered by 2. In the End Phase, remove all designation counters from play.

SHIP MISSILE BAYS ▼

Missile Bays launch swarms of self-guided missiles, programmed to hunt down and attack a specific target. They usually inflict heat damage, with high explosive, plasma or (rarely) nuclear warheads. Missiles usually serve as a deterrent; a ship captain who knows that he's being hunted by a swarm of missiles will usually take on a defensive posture, thus handing the flow of battle over to his opponent.



A ship missile bay (labeled under the Datacard's Notes as S-Mis) does not fire like other ship weapons. It may only be used in the End Phase of a turn; other than that, it may not fire. To fire a swarm of missiles, a target must be selected and a lock-on roll made. The lock-on roll is an opposed Skill roll between the attacker and defender, modified only by each unit's Electronics rating. The lock-on roll is limited by the Missile's fire arc and range, but not by the bay's Accuracy (that comes into play later).

If the lock-on roll fails, no missiles may be launched from that bay this turn. Some ships have multiple missile bays (denoted by the Rapid Fire notation under the component's Notes column). They may make one lock-on roll for each missile bay, choosing a different target for each one, if desired.

If the lock-on roll succeeds, a swarm of missiles is launched. Place a missile counter on top of the target ship. These missiles are considered to be in transit somewhere between the two ships, getting their bearings, planning an attack run and actually traveling to their target. Each missile swarm launched by a ship reduces its Avoidance by 1.

In the next turn's End Phase, all missiles launched in the previous turn arrive at their targets and attack. Note that it doesn't matter where the target is in relation to the ship that fired the missiles. The range and fire arc listed on the Datacard are used only for the lock-on and represent limitations of the ship's targeting computers; after launch, the missiles will hunt down their target no matter where it runs.

When a missile swarm attacks, the Opposed Skill roll works just like any other normal attack. The missiles use the firing ship's crew Skill level, so if there's an Ace ship on your side, make sure you keep track of which missile swarms it launched. In the case of targets with multiple facings, the defender may decide which facing the missiles will attack (presumably attacking the stronger side).

POINT DEFENSE SYSTEMS (PDS) ▼

Ships are equipped with extensive arrays of **Point Defense Systems**: these are lasers and particle accelerators that are designed to protect the vessel from micrometeorite impacts in the course of space travel. As it happens, however, these systems also have some very useful combat functions.

Like a Missile Bay, PDS is a special weapon, and works differently from normal weapons. A ship's PDS may operate in one of two modes each turn. The mode must be chosen in the Initiative Phase and cannot be changed for the rest of the turn unless a Command Point is spent. Depending on which mode, Standard or Shield, the PDS is operating in, the ship has a differing set of defensive profiles. No matter what mode it is in, using PDS never alters a ship's Avoidance.



◇ STANDARD MODE

Offense: Standard mode uses the system's laser beams to specifically target and shoot down missiles and other vehicles at fairly long distances. Standard PDS may be used as a normal weapon, as part of a Fire Weapons Action, but the true power of Standard PDS lies in its use as an opportunity-fire weapon.

Standard-mode PDS is the only weapon in the basic rules that may attack during another unit's Action without using a Command Point. Standard-mode PDS may make one free attack anytime a unit enters its firing range during a turn. The free attack is also allowed whenever the ship moves so that an enemy unit comes into PDS range. However, this attack may only be used against the currently-moving unit, and may only be used once per target, per turn. Once the free attack is rolled, if the target survives, it may continue with its phase.

This represents the PDS' control computer automatically targeting and firing a single quick shot at any approaching enemy unit. Firing the PDS as part of an Action, on the other hand, represents human crewmembers taking control of the PDS and hitting an especially dangerous target a second time. This 'automatic shot' ability is potentially very powerful, since it makes it dangerous for any number of units to even approach a ship.

Defense: in Standard mode, the PDS adds its Damage Multiplier as a bonus to the ship's Defense Rolls against Missile attacks. This ability works automatically against every incoming Missile attack as long as the PDS is in Standard mode.

◇ SHIELD MODE

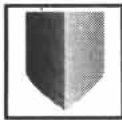

Offense: Shield mode focuses the system into a low-power radar; any physical object detected by the laser pulses then becomes the focus of a close-range barrier of coherent light, damaging anything that tries to pass through with a crisscrossing grid of laser beams, as well as providing minor protection from projectiles.

Mark a ship in shield mode with a Shield-mode PDS counter. Shield PDS requires no Actions to use. It is always on, and will damage anyone foolish enough to blunder into its field. Any unit that comes into physical contact with a ship whose PDS is in shield mode is immediately and automatically hit with an amount of damage equal to the PDS' Damage Multiplier multiplied by the result of a Skill roll. The victim gets no Defense Roll whatsoever. Units that begin the turn in physical contact with a ship that has turned its PDS to shield mode do not take any damage from the shield until they actually pass through it. This will occur either when the ship moves away from the unit, or if the unit chooses to move away from the ship. Thus, if a unit manages to stay in close combat with the ship for the entire turn, it will remain 'under' the shield and take no damage.

Ships that run into PDS shields on other ships take the shield-inflicted damage as a single hit on the hit location chart. PDS shields do not interfere with one another, being laser light. If two ships touch each other's PDS shields, both ships will take the appropriate damage. Then again, the only way for two ships to touch each other is a ram, so both ships probably have more important things to worry about than a bit of PDS damage. Likewise, a ship cannot move its shield into contact with an exo-armor or fighter unless it makes a ramming attempt (good luck).

Defense: Shield-mode PDS is used out of combat to deviate or disintegrate micrometeorites whose impacts could harm the ship, essentially 'burning' a clear path through space. In this mode, PDS cannot independently target incoming missiles for destruction (possibly negating the attack entirely), but it is capable of shearing away some or all of the mass of a cannon round, either harmlessly disintegrating it or causing it to detonate prematurely.

In shield mode, the PDS reduces the damage inflicted by 'P' type hits by a number of points equal to the PDS' Damage Multiplier, before the damage is multiplied by the attacker's Margin of Success. In many cases, this will reduce the damage to zero. Note that attacks made at 'C' range are not affected by the shield. Shield-mode PDS has no effect on incoming Missile weapons. Energy ('E') weapons are unaffected by PDS in any of its modes.

DRONES ▼

In the 23rd century, a dedicated computer is capable of not only piloting a spacecraft, but also of guiding it through a battle or surveillance mission. Such uncrewed craft are collectively known as **Drones**, and perform a variety of battlefield roles that are either too dangerous or too precise for humans.

Drones are divided into three classes. Every Solar nation has its own models of Drone in each class, but the class designations (much like the common use of naval terms like "destroyer" and "frigate") are used uniformly throughout the Solar System. All of the Solar Nations use similar Drone types, with very little real variation between them. Although Venusian Drones do tend to be better-constructed and generally superior to foreign Drones, the differences are too minor to make much of a difference in Lightning Strike.

Class I Drones are the simplest and most straightforward Drone designs, little more than precocious missiles with basic decision-making abilities. **Class II Drones** are somewhat brighter than Class I Drones, in that they actually have some sense of self-preservation. Such Drones are still considered highly expendable, however, and have tasks that put them in the way of great harm. **Class III Drones** are the most complex of the three Drone classes, and are generally not considered expendable on the battlefield; they are difficult to obtain and expensive to replace. The decision-making processes of Class III Drones are advanced enough such that they can be trusted with weapons and the discretion to use them on the battlefield.

When a unit that carries Drones is chosen as part of a force, you will need counters or miniatures for both the unit itself and for its Drones. Generally, one should have enough Drone counters to allow placement of two full turns' worth of Drone launches (see below). If different Drone types are being used, each Drone counter must be clearly marked with its type, to distinguish it from other Drones. Also, if more than one side is using Drones, each side's Drones must be clearly marked to show whom it belongs to. Counters for the seven different Drone types presented herein are included with this book; feel free to photocopy them and mark them with appropriate national colors.

Each Drone-carrying standard unit must have an Ordnance Counter placed on it when it first appears on the table. As long as the Ordnance Counter is on the unit, that unit may launch Drones. When the Ordnance Counter is removed, the unit has run out of Drones (or suffered a mishap with its Drone bay), and may not launch Drones for the rest of the game.

If different Drone types are being used, each Drone counter must be clearly marked with its type, to distinguish it from other Drones. Also, if more than one side is using Drones, each side's Drones must be clearly marked to show whom it belongs to.

Shipkiller Drone I

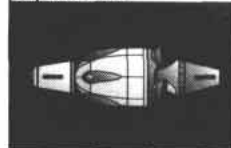

DRONE CARRIERS ▼

A Drone-carrying unit's Datacard will look somewhat different from the Datacards of more typical units, reflecting the different set of data that must be provided for Drones. A unit's Drone-launching capabilities (also known as its Drone bay) are listed in the Attacks section of its datacard. However, there are only three pieces of information in a Drone bay entry; no Accuracy, Range, Arc or other stats are listed, because Drones don't use them. It is possible for a Drone bay to have special characteristics (like Slow) that affect the conditions under which it may be used, but this is rare.

Drone Class or Type: this specifies what types of Drones the unit may launch. This entry may either specify one or more entire Classes of Drones, allowing the unit to launch any Drone in those Classes, or one or more individual Drone types.

Rate: the number of Drones the unit may launch each turn. Regardless of how many Drones are launched, launching Drones costs one action. For ships, Drones are launched as part of a Fire Weapons action; launching Drones does not alter a ship's Avoidance.

Reload Threshold: When a unit uses an Action to launch Drones, place the Drones on the field as described next page, and then make a Skill Roll against the Reload Threshold. For every individual Drone the unit has launched this turn (including Drones launched in previous Actions as well as the Drones just launched), apply a cumulative -1 penalty to the roll. Note that Drones launched in a previous turn do not count toward this penalty. If the roll succeeds, there are no additional effects. If the roll fails or fumbles, remove the unit's payload counter; no further Drones may be launched from this unit.

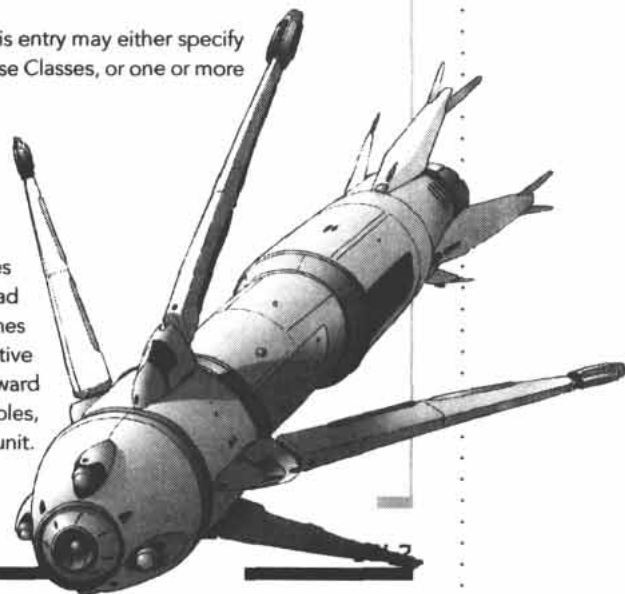



◇ SHIP DRONE CARRIERS

Ships, for the most part, can carry many more Drones than standard units can, and are thus less affected by the prospect of running out in a fight. There are two ways of keeping track of shipboard Drones:

1) If the ship carries a limited number of Drones, there will be a number of checkboxes on the ship's Datacard, on the Drone weapon entry. Every time a Drone is launched, cross off one box. When all the boxes are filled, Drones may no longer be launched.

2) If the ship carries a very large number of Drones, such that it is not likely to run out of them, it has a Reload Threshold just like standard units. When a ship fails its reload Threshold, however, its Drone-launching abilities are not permanently disabled, unlike standard units. Instead, a single damage box is marked off in the Drone Bay's entry on the ship's Datacard, simulating a loading error or delay. When the damage is repaired, the ship may continue to launch Drones as normal.

Shipboard Drone bays take damage like any other weapon, becoming temporarily nonfunctional when damaged, and being completely destroyed when Overkilled. When a Drone bay is damaged, the stored Drones are not harmed, but if the bay is destroyed, then all carried Drones are also destroyed. Launching Drones does not affect a ship's Avoidance.

▼ LAUNCHING DRONES

Drones always start a battle inside their mother unit. Standard units may launch one or more Drones, up to their Drone bay's rate, by spending one action. A Crippled standard unit may launch only half the number of Drones it may normally launch, rounding up.

Ships may launch Drones up to their Drone bay's rate as part of a Fire Weapons action.

When Drones are launched, they must be placed on the table in contact with the unit that just launched them. From that point on, they are considered independent units, with their own actions. Once they are launched, Drones do not have to be associated with their mother unit at all; they can go anywhere on the battlefield, regardless of where their mother unit goes. If the mother unit is destroyed, the Drones may continue operating as normal.

After the Drones are placed on the table, the launching unit either rolls against its Reload Threshold or crosses off Drone boxes, depending on its type.

Due to the mechanics of the game, it is theoretically possible for an infinite number of Drones to be launched by a single unit. Under most circumstances, this should not be a problem for the same reason ammunition is usually not a problem for vehicles; neither the Drone nor its mother unit are expected to survive long enough to cause reality-bending problems.

If, however, an excessively large number of Drones is about to inundate the table, Players may limit the maximum number of Drones on the table to the total Rate of all Drone bays in play, multiplied by two. Put more simply, once you run out of Drone counters, it will be impossible to launch more Drones until some of the Drones that are already in play are destroyed.

▼ DRONE DATA CARDS

Drones use a much-simplified datacard compared to standard unit datacards. Several types of Drone cards are included with this book (see page 110), representing generic Drones used throughout the Solar System. The differences between the Drone Datacards and the standard Datacards are explained below.

Threat Value: Drones do not have individual Threat Values. They are worth no victory points beyond the TV cost of their mother unit, which already takes into account the offensive and defensive power of the drones it carries.

Skill Threshold: Drones are fairly predictable in battle and thus never roll dice. For any situation in which a Drone must perform a Skill check, the Skill Threshold listed on its datacard is treated as the result of the Skill check.

Protection: Drones are not provided with Protection ratings; any hit from a battlefield weapon will destroy them automatically.

B.3.2

B.3.3

DRONE MOVEMENT AND ACTIONS ▼

Drones move and act during the Main Phase, after all other non-ship Groups have moved and acted.

A Drone has one Movement value on its Datacard. Drones may not use Overthrust or Evasive movement types. Drones can have different facing types, however, reflecting their design and purpose. These facing types are identical to the ones used for standard units.

Drones get one action per turn. They may Aim; doing so reduces their Skill Threshold by one when defending, and increases it by one when attacking.

If the Reaction Attack rule is being used, Drones may Reaction Attack. However, unlike other units, which can choose to leave a Stun counter in place indefinitely, a Drone that gets a Stun counter cannot take any other action besides removing the Stun counter. In fact, the only way a Drone can acquire a Stun counter is by using a Reaction Attack, since Drones are automatically destroyed by any kind of combat hit.

Note that even Shipkillers and Exokillers may Reaction Attack, even though the Stun counter will have no effect on them (because they are already automatically destroyed when they attack because of the SD characteristic on their warheads).

Some combat options are not available to Drones: Drones may not ram (for simplicity's sake); Drones may not use Command Points; and Drones may not combine attacks.

DRONE EXAMPLE ●

A Sentry Drone is being shot at by an exo-armor. The exo-armor rolls normally to attack, and compares its roll to the Drone's Skill Threshold of 4. The exo rolls a total of 4, just barely missing the Drone. Later that turn, the Sentry Drone shoots at the exo. The Drone's Skill Threshold is 4, plus its missiles' Accuracy of 1, for a total Threshold of 5. The exo must roll a 5 or better on its Defense Roll, which it does.

The next turn, the exo shoots at the Drone again, and this time rolls a 5. Even though the Margin of Success is only 1, a hit of any type will destroy a Drone, so the Sentry is obliterated.

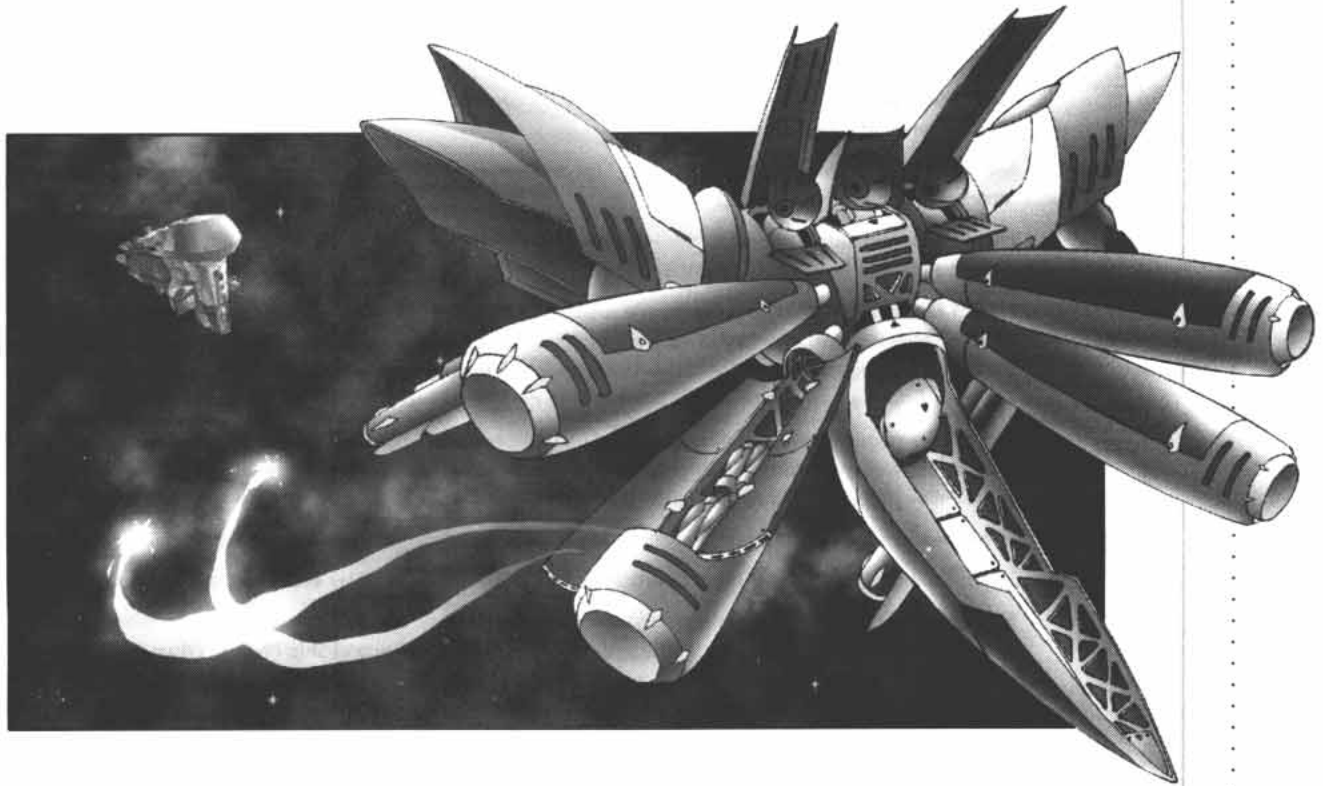

b.e.h.



▶ WEAPONS AND EQUIPMENT

The various datacards included in this book represent the basic “no frills” versions of the units and ships. All units can be upgraded to some extent. This section lists some of the possible add-ons for standard units and ships, and also provides rules for their use. A table of the costs and stats for each add-on is located on page 73.

No more than 10% of a force’s total TV may be spent on Weapons and Equipment. This limit may only be changed if all Players agree before the game begins. Refer to the fleet lists (Chapter 7) for further equipment availability restrictions for each nation. To mark the tabletop miniatures as being upgraded, Players can use counters, bits of sticky-notes, or (preferably) actually build parts for the miniatures. Players can also use pencil or dry-erase markers to make notes on the units’ datacards.

▼ EXO-ARMOR AND FIGHTER WEAPONS



These are weapons systems that can be mounted to hardpoints or bays on standard units, increasing their firepower. Some of the weapons specify the use of an Ordnance counter. This is a counter used to mark a unit that is carrying a limited-use weapon, just as it is for Drones (see 6.3). Once the weapon runs out of uses, the Ordnance counter is removed. In order to aid Players in keeping track of which unit is carrying what ordnance, Players may wish to write the type of ordnance being carried on the counters.

Unless otherwise specified, weapons added to a fighter will always have a Fixed Forward arc and equipment added to an exo-armor will always have a Forward arc. Exo-armors may carry one add-on weapon, while fighters, due to their payload bays and solid construction, may carry two; units that carry three mounted weapons may not carry add-on weapons at all. Some specialized units may carry more or less than the usual number of add-on weapons; this is noted on the units’ datacards. A unit may carry more than its permitted allotment of add-on weapons; in addition to the basic TV costs of the weapons, an additional TV cost is applied. This cost is equal to the cost of the most expensive add-on weapon on the unit, multiplied by the number of add-on weapons the unit is carrying.

See the table on page 73 for game statistics for the following weapons. Damage from add-on weapons is halved if the carrying unit is Crippled, just like built-in weapons.

Swarmers: Smart cluster missiles. Use an Ordnance counter to mark the unit; remove the counter after the Missiles have attacked once.

Light Missiles: Anti-exo missiles. Use an Ordnance counter to mark the unit; remove the counter after the Missiles have attacked once.

Medium Missiles: Multi-purpose missiles. Use an Ordnance counter to mark the unit; remove the counter after the Missiles have attacked once.

Heavy Missiles: Large anti-ship missiles. Use an Ordnance counter to mark the unit; remove the counter after the Missiles have attacked once.

HARM Missile: Radiation-seeking missile. Use an Ordnance counter to mark the unit; remove the counter after the Missiles have attacked once. Same stats as Medium Missiles, but they gain a +3 attack roll bonus if the target is using standard ECM. If the Reaction Attack rule is in use (page 34), HARMs may also be used to Reaction Attack a unit immediately after it rolls to Ping, Tag or to use ECCM or targeted ECM.

Assault Railgun: A heavy gun often mounted on bomber units in place of missiles. Use an Ordnance counter to mark the unit; every time the railgun fires a shot, make a die roll. On a 1-4, the railgun is jammed or out of ammunition, and the Ordnance counter is removed.

Drone Rack: These come in various types. Mark the unit with an Ordnance counter and see 6.3 for rules.

Beam Cannon: Heavy, fixed-mount particle accelerator weapon used by assault units.

Sentry Pod: Fires flares, chaff and decoys to distract the enemy. Use an Ordnance counter to mark the unit. The Sentry Pod may be used at any time in the First Ship, Main or Second Ship Phases. When the Sentry Pod is used, remove its Ordnance counter and replace it with an Evasion counter (see *Evasion*, page 34). The Evasion counter is removed as normal when the unit next activates.

Melee Weapons: various implements for use in close combat. The unit’s Close Combat Optimized Rating is increased by one. This add-on has no effect on units without the Close Combat Optimized Perk.

EXO-ARMOR AND FIGHTER EQUIPMENT ◇

These are additional items that can be installed into or onto fighters and exo-armors. A fighter or exo-armor may have one item from the following list in addition to any add-on weapons it already has. A unit may carry more than one piece of equipment; in addition to the basic TV costs of the equipment, an additional integration fee equal to the cost of the most expensive piece of equipment, multiplied by the total number of add-ons pieces of equipment the unit is carrying, is applied.

Anti-Missile System: these small laser turrets add Antimissile System (Rating 2) to the unit.

EW Pod: the unit gains either ECM 2/ECCM 3 or ECM 3/ECCM 2. Does not add to existing EW systems.

Target Designator: Range C/20, Acc +1/0. See 6.2.1 for Target Designator rules.

Executor Copilot: intelligent computer-controlled systems. The unit gains a bonus Action.

Advanced Fire Control: the unit receives a +1 bonus to all its attack rolls.

Advanced Sensor Suite "Snoopy Pod": The unit can automatically detect cloaked units within 20cm. Units in deep cloak may not reappear within 20cm of a unit with a snoopy pod. Stealthed units do not receive their stealth Avoidance bonus when being attacked by a unit with a snoopy pod.

Ablative Armor: layers of extra protection. The unit gains Multiple Redundancy (see 6.1.1) at Rating 5.

Battle Arms: crude but effective grasping claws. The unit's Close Combat Optimized Rating is increased by one. Units without the Close Combat Optimized Perk now have the Perk at Rating 1.

Shield: additional forward armor, either handheld or attached to the hull itself. The unit's Front Protection values are all increased by 1.

Booster Pack: increased fuel and thrusters. The unit's movement values are increased by 10 cm each.

Vernier Module: Extra maneuvering thrusters. The unit's Front Avoidance is increased by 1.

Chameleon Refit: Modular photoskin covering and radar-absorbing material. The unit's Avoidance values are lowered by 1. The unit gains Stealth (2) and Cloak (0).

EXO-SUIT EQUIPMENT ◇

An exo-suit squad may carry as many pieces of equipment as the Player desires, but it may not carry duplicate pieces of equipment.

Claymores: These directional mines give the exo-suits an edge in close combat. The Close Combat Optimized rating is increased by 1.

Toolkits: These compact tools allow the squad to make emergency repairs to any standard unit. If the squad is in base-to-base contact with a friendly unit, it may spend one Action to either remove a Stun counter or replace a Crippled counter with a Stun counter. The squad may not use the toolkits on itself.

Booster Pack: Increased fuel and thrusters. Double the squad's movement allowance.

Shields: Bolt-on or hand-held armor. Add one to the squad's Stun, Crippled and Overkill Thresholds.

Target Designator: Range C/20, Acc +1/0, see section 6.1.1, Target Designator.

SHIP EQUIPMENT ◇

A ship may carry as many pieces of equipment as the Player desires, but it may not carry duplicate pieces of equipment.

Proximity Mines: These explosive modules are designed to protect ships in Close Combat. Use an Ordnance counter to mark the ship. At any time during the First Ship Phase, Main Phase or Second Ship Phase, the ship may elect to damage every unit (friend or foe) within ten cm with an amount of damage equal to 4P multiplied by the result of the roll of one die. After the damage has been dealt, roll another die. On a 1-3, the Ordnance counter is removed; otherwise, the counter remains and may be used again.

HEAT-Resistant Armor: The ship's Protection ratings are all increased by +3 when being attacked with an "E"-type weapon.

Decoy Pod: When using the Spoof Action, the ship may add one to its roll.

Diogenes System: When using the Ping Action, the ship may add one to its roll.

Repair Bots: When using the Damage Control Action, the ship may add +1 to its roll.

EW Rig: The ship may use ECM and ECCM at Rating 3 with no penalty to Avoidance.

Target Designator: Arc F, Range 30, Acc 0. This system must be used as part of a Fire Weapons Action, and reduces the firing ship's Avoidance by one for each shot. This system cannot be used if the ship's Electronics are damaged. See 6.1.1, Target Designator.



► SHIP ABILITY: LAUNCH AND RECOVERY

B.3

The value of a carrier lies not in its firepower, but in its ability to carry hordes of exo-armors and fighters into battle, and repair them afterward. Although units cannot be repaired by a carrier in the middle of a battle, they can use the carrier's hangar as a hiding place, or to get an extra speed boost from its catapults.

To land on a carrier, a standard unit must spend one Action in physical contact with the carrier's counter. At the end of its phase, the unit is taken aboard the carrier and may no longer be the target of any attacks. Remove the unit from the table and place it on the carrier's Datacard. Warship missiles hunting the unit will target the carrier, instead.

To leave a carrier, a unit can simply drop out of an airlock. The unit appears on the playing field adjacent to its mothership during the Main Phase and may move and act as normal.

Fighters and exo-armors may also use a carrier's catapults to launch into battle. A carrier may launch as many units in a turn as it has catapults; this costs it no Actions, nor does it alter its Avoidance value. Catapults may be used at any time during the Main Phase; simply place the unit next to the carrier and move it straight ahead up to 20 cm. A launched unit may move and act as normal after it launches, once its activation comes up.

Each exo-armor or fighter occupies one bay in a carrier's hangar. Any ship may carry a number of exo-suit squads equal to its Size, and may carry an essentially unlimited number of infantry (although common sense should still limit Players' creativity). Exo-suits and infantry may not use catapults (although it might be morbidly amusing to try).

Note that it is possible to have many more units on the field than there are bays to carry them. One may assume that the "extra" units arrived at the battle under their own power, or by clamping on to the hulls of friendly ships.

► STANDARD UNIT ABILITY: TAGGING

B.4

Most exo-armors, fighters and exo-suit squads would be hard-pressed to do significant damage to a warship on their own. Such a unit can, however, use its weapons and comm systems to help its friends get a better shot on a big ship.

Any exo-armor, fighter, exo-suit squad or infantry squad may tag a warship. **Tagging** is considered an Action, and will thus prevent most units from attacking and tagging in the same turn. A unit may only tag a target that is in its primary attack arc (the arc of the first attack on its Datacard). The maximum range of a tag attempt is determined by the tagging unit's Electronics rating (see table below).

Other than lowering the target ship's Avoidance by one, tagging does no damage. Tagging may only be used against ships; it has no effect on smaller units that are too nimble for reliable targeting. Tagging may be used as part of a Combination Attack.

▣ TAGGING RANGE

Electronic Rating	Range	Electronic Rating	Range
-1 and below	5 cm	+2	30 cm
0	15 cm	+3	40 cm
+1	20 cm		

▣ TAGGING ROLLS

The tagging roll is an opposed roll between the tagging unit and the target ship.	
Tagging unit rolls a Skill test modified by:	
•	Electronics rating
•	Aiming (if applicable)
•	Overthrust (if applicable)
Target ship rolls a Skill test modified by:	
•	Electronics rating

EXO-ARMOR AND FIGHTER WEAPONS

Name	Game Stats and Notes	Ordnance Counter?	TV Cost
Swarms	Rng C/20, Acc +2, Dam 2E, Mis, Sk2	Y	1
Light Missiles	Rng C/30, Acc +1, Dam 4E, Mis	Y	1
Medium Missiles	Rng C/20, Acc 0, Dam 6E, Mis, AS1	Y	1
Heavy Missiles	Rng C/20, Acc -1, Dam 8E, Mis, AS2	Y	1
HARM	Rng C/20, Acc 0, Dam 6E, Mis, AS1, EH	Y	3
Assault Railgun	Rng 30, Acc -1, Dam 4P, R1, AD, Slw	Y	3
Drone Rack A	Shipkiller Drones, Rate 4, Reload 2	Y	3
Drone Rack B	Drones I, Rate 4, Reload 2	Y	4
Drone Rack C	Drones I, Rate 2, Reload 2	Y	3
Drone Rack D	Drones I, Rate 1, Reload 1	Y	4
Drone Rack E	Drones II, Rate 2, Reload 3	Y	2
Drone Rack F	Drones II, Rate 1, Reload 1	Y	4
Drone Rack G	Drones III, Rate 2, Reload 2	Y	4
Drone Rack H	Drones III, Rate 1, Reload 1	Y	5
Drone Rack I	Drones I, III, Rate 2, Reload 1	Y	6
Drone Rack J	Drones II, III Rate 2, Reload 1	Y	6
Drone Rack K	Drones III Rate 2, Reload 1	Y	7
Beam Cannon	FF, Range 20/40, Acc -2/-1, Dam 5E/4E	N	2
Sentry Pod	automatic Evasion	Y	1
Melee Weapons	Close Combat Optimized Rating +1	N	1

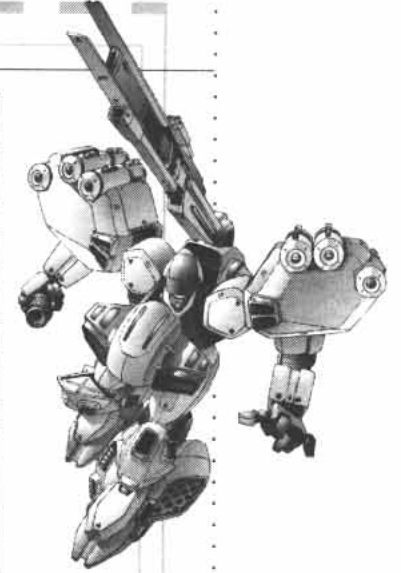

EXO-ARMOR AND FIGHTER EQUIPMENT

Anti-Missile System	Missile Defense (2)	N	2
EW Pod	ECM 2/ECCM 3 or ECM 3/ECCM 2	N	3
Target Designator	Range C/20, Acc +1/0	N	3
Executor Copilot	+1 Action	N	10
Advanced Fire Control	+1 bonus to attack rolls	N	10
Snoopy Pod	Detect cloaked and stealthed units	N	5
Ablative Armor	Multiple Redundancy (see 6.1.1) at Rating 5	N	4
Battle Arms	Close Combat Optimized Rating +1	N	1
Shield	Front Protection values are all increased by 1	N	2
Booster Pack	+10 cm movement	N	2/fighter, 4/exo
Vernier Module	Front Avoidance +1	N	5
Chameleon Refit	Stealth (2), Cloak (0), -1 Avoidance	N	10

EXO-SUIT EQUIPMENT

Booster Pack	Movement values x 2	N	3
Claymores	Close Combat Optimized Rating +1	N	1
Shields	Protection values all +1	N	2
Target Designator	Range C/20, Acc +1/0	N	3
Toolkits	spend 1 Action to repair other standard units	N	3

SHIP EQUIPMENT

Decoy Pod	+1 to Spoof rolls	N	10
Diogenes System	+1 to Ping rolls	N	5
EW Rig	ECM 3, ECCM 3, no Avoidance penalty	N	20 (30/heavy ships)
HEAT-Resistant Armor	Protection values all +3 vs "E"-type attacks	N	5
Proximity Mines	every unit within ten cm takes 1d6x4 damage	N	10
Repair Bots	+1 to Damage Control rolls	N	5
Target Designator	F, Range 30, Acc 0, -1 Avoidance	N	10



► FLEET LISTS

It is said that diplomats use lies to make policies, while armies use honesty to enforce them. This chapter provides game-context descriptions, rules and guidelines for these tools of politics. Each fleet list provides a description of the various standard units and ships used by one of the military organizations in the Solar System. In this book, the three superpowers (Jupiter, Earth and Venus) are presented; fleet lists for other, smaller forces will make their appearance shortly in a latter volume. Each list also gives rules and limitations for building a fleet, and ends with a description of organizational and behavioral quirks.

When choosing a force for a battle or to create a task force, Players will have to pay attention to both the Grouping limitations and the unit restrictions of their chosen force. For instance, units that are described as "special duty" units in a fleet list can usually only be taken in limited numbers. If a Player wishes to add more units than the army list allows, he may do so; additional units cost double their basic TV. Each fleet has access to certain common units (such as cargo ships). The descriptions for these common units are in the Neutrals section (page 92).

Many units will have specific Options listed under their individual descriptions. The stats and costs for these upgrades will be listed there, or can be copied from other units. In any fleet, no more than 50% of the units of a single type (e.g. Wyverns or Pathfinders) may use these Options. Options do not count as add-on weapons and equipment, and do not count toward a force's 10% TV limitation for such items.

Each fleet list provides a listing of how that particular fleet uses the weapons and equipment described on page 70. **Common** equipment is freely available to the fleet. **Restricted** equipment is harder to come by. A fleet may buy one piece of Restricted equipment at its standard cost for every ten units (standard or ship) it has; additional Restricted items cost double. **Experimental** equipment is available only in the most limited quantities. A fleet may have one such piece of equipment at its standard cost; additional Experimental items cost triple. If an item described in Chapter 6 is not listed in a fleet list, then that item is not available. When choosing a force for a battle, no more than 10% of the force's total TV may be spent on weapons and equipment. Unless otherwise specified, these may be assigned to units however the Player desires.

▼ THE SOLAR SYSTEM OF 2214

The Solar System of 2214 is a tense place. It has recently suffered the ordeal of open warfare between two immensely powerful forces. At the end of 2213, the Solar System paused at the edge of an abyss of destruction and carefully pulled back. In the past six months, however, humanity's thirst for warfare has steadily grown, and many people fear the next decade will see an end to the golden age humanity has worked so hard to attain.

The major powers, the Central Earth Government and Administration and the Jovian Confederation, are locked in a cold war. Pulling strings from the shadows, a third major power, Venus, is making dangerous decisions that may very well tip the precarious balance and plunge the Solar System into a full-scale war from which no one will be spared. Two recent events have brought humanity to this tragic point in history.

In 2210, an Earth scientist researching a remarkable new human/machine interface technology petitioned the Confederation for political asylum. The JAF sent an inexperienced team of operatives to extract the scientist from a conference on Venus. The team fled back to Jovian space; the resulting desperate series of events came to be known as the Odyssey. During the chase, CEGA forces destroyed a colony dome in Copernicus Crater on the Moon, unknown forces destroyed the prototype Martian space elevator, and a rogue CEGA Navy fleet very nearly succeeded in destroying the Jovian capital station of Elysée.

In 2213, the Centennial Anniversary of the founding of the Jovian Confederation, war broke out between the totalitarian Martian Federation and the Martian Free Republic. Both CEGA and the Jovian Confederation saw this war as the perfect opportunity to rattle their own proverbial sabers; both nations sent fleets to support and protect their allies, the Federation for CEGA and the Republic for the Jovian Confederation. Their ostensible mission was to protect Martian orbital facilities and limit the ground warfare below. However, a Solar Cross distress call gave both nations another excuse, this time to intervene directly. The result was a small-scale dogfight between the two superpowers that rapidly escalated into a full fleet action. The entire war came to a screeching halt when the Confederation fleet's command ship, the Godsfire-class JSS Gilgamesh, mortally wounded by CEGA forces, crashed into the Martian Federation capital of Kurtzenheim, killing over six million people in a fiery blast with a five-kilometer radius crater at its center.

THE JOVIAN CONFEDERATION ◀

Barely a century old, the Jovian Confederation is perhaps the most powerful nation ever constructed by humankind. Its founders fled the strife and downfall of the Inner Solar System, outward to the largest of planets, Jupiter. There, hampered by radiation and the lack both of solid ground and abundant sunlight, they forged a society housed in hundreds of orbital space colonies. The Confederation was born in the early years of the 22nd century when the colony cylinders in orbit around Jupiter proper, known collectively as Olympus, allied themselves with the colonies in Jupiter's Trojan asteroids, Vanguard Mountain in the leading cluster and Newhome in the trailing cluster, in 2113. The Confederation claimed more territory as its own than any other human civilization had ever dared.



2-1

The Jovians built vast automated mining complexes, gargantuan cargo massdrivers, self-replicating factories and countless other technological innovations. In 2162, the Jovians built the first humanoid space fighters, known as exo-armors, ushering in a new era of warfare. Other nations have copied, modified and improved all of these technologies, but the Confederation still reigns supreme in the quality and quantity of exo-armors it can field.

The events of the Odyssey were a rude awakening for the citizens of the Confederation. They had eyed the formation of CEGA in 2186 with a certain amount of distrust, and the two nations had engaged in several minor skirmishes and "police actions" in the years that followed. When the allegedly rogue CEGA fleet entered Jovian space and dared to attack the Capital, however, the nation was outraged. Arms production increased steadily, and the Agora, the ruling body of the Confederation, commissioned the design and construction of new warships that would enable the Jovians to take direct action against Earth if need be.

The Battle of Kurtzenheim in 2213 was a major blow to the Confederation's national pride. The fleet's role was supposed to have been that of savior and protector for the Free Martian Republic, but in the end, it was a Jovian spaceship that killed over six million innocent people. Accident or not, that single event is unpardonable, and it is reflection upon that event that both keeps the Jovians at bay and fuels their hatred for CEGA.

JOVIAN ARMED FORCES ▼

Although the citizens of the Jovian Confederation are rethinking the nation's role in the Solar System, other minds prevail within its military, the Jovian Armed Forces. Despite the faltering national self-image, the JAF High Command continues to appropriate funds to improve its fleets and to maintain its state of combat readiness. Meanwhile, the remnants of the Mars Taskforce have returned home, undergone repairs and been successfully reintegrated with their respective Divisions.



The soldiers of the Confederation tend to be young, enthusiastic and well trained, but are also perhaps the most idealistic and pampered military personnel in history. During the cold war build-up of recent years, the Jovian military has seen little shortage of equipment. The only question nagging the minds of the Jovian High Command is whether the pilots who use that equipment will be able to deal with the true face of war. The events of the Battle of Kurtzenheim have shaken the nerves of countless new recruits.

Two interesting traits of the Jovian Armed Forces are its unit-to-unit flexibility and independence. These traits are true at all levels of the JAF, from the high-level separation of the fleet into Alpha, Beta and Gamma Divisions down to the smallest of flights. Most common are flights made up of two or more different units, each one hopefully covering the weaknesses of the others. No matter how it is separated or broken up, the different constituent components of the JAF are capable of acting autonomously to a great degree.

Each of the JAF Divisions is assigned to the space in and around one of the three Jovian states. Alpha Division is charged with the protection of Vanguard Mountain. Beta Division is assigned to Newhome. Gamma Division protects Olympus. Nearly all new recruits are assigned to Gamma Division; the JAF frequently reassigns its veterans to Alpha and Beta Divisions. The newest equipment, from warships on down to exo-suits, however, is most commonly assigned to Gamma Division.

JAF taskforces often comprise elements from each of the three Divisions in order to minimize the impact of the formation of the taskforce. Taskforces are usually built around a carrier, which serves as a command ship, and its escorts, which provide anti-ship firepower and additional fighter-carrying capability. Most taskforces have four to six escorts for each fleet carrier and one or two escorts for each light carrier. The most prominent taskforces have traditionally been assigned a Godfire supercarrier as a symbol of Jovian pride and might.



S
T
S

F
L
E
E
T

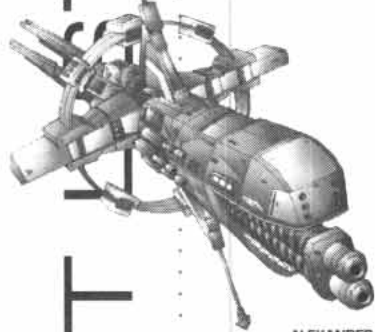

ALEXANDER

LINE SHIP: ALEXANDER DESTROYER

Similar in purpose to the smaller Athena-class destroyers, the Alexander-class ships are longer-ranged and are able to operate without resupply for greater periods of time. They are commonly used as escorts and patrol vessels and are usually paired with a light carrier. In fleet operations, their speed and armament make them well suited to quick strikes and raids against flank or rear units. The armament of an Alexander is more or less equivalent to that of an Athena, albeit with a somewhat stronger focus toward anti-fighter capabilities.

Options: +10 TV: Replace Lasers with KKC's (Prot 5/10/15, Range 25/50, Acc 0/-1, Dam 5P, AP, R1, St, FI)

LINE SHIP: ATHENA DESTROYER

Graceful and agile, the Athena has been described as a "capital ship that thinks it's a fighter." Its poor weapon arcs are made up for by its truly awe-inspiring forward fire capability. Early on in their production, Athenas were named after Greek provinces of old, such as Athens, Lacedaemon, Ithaca and Marathon. After those ran out, however, the JAF expanded the convention to include mythical or real places associated with heroism and valor.

LINE SHIP: THUNDERBOLT CRUISER

One of the oldest ship classes still in service with the JAF, the Thunderbolt class ships appear headed for retirement and mothballs now that the Athena- and Alexander-class destroyers have taken over many of its original duties. With the recent preparations for a direct assault on CEGA-occupied Earth, however, the need for a light orbital artillery platform has arisen. Rather than design an entirely new class of ship to serve this role, a simple modification is planned that will replace the Thunderbolt's characteristic particle cannon with a space-to-ground railgun.

Options: +10 TV: Replace Particle Cannon with Railgun (Range 20/60, Acc 0/-1, Dam 8P, AD, Sw3, PH0)

LINE SHIP: JAVELIN MISSILE CRUISER

The Javelin is a modification of the venerable Thunderbolt cruiser, designed to provide versatile long-range fire support to friendly ships and squadrons. The characteristic oversized keel of the Javelin houses massive, long-range anti-ship missiles. With the recent advent of the use of Drones in battle, JAF High Command has initiated plans to convert the keel into a giant Drone bay, making the Javelin a dedicated Drone carrier — which is practically what it is today, since its missiles are, in effect, Drones themselves.

Options: +10 TV: Exchange Missile Bay for Drone Bay (Drones I-III, Rate 3, Reload 3)

LINE SHIP: CORSAIR FRIGATE

Introduced in 2191, the Corsair is a small and nimble fleet support ship designed to outflank enemy positions quickly while using its heavy missile bay to keep pursuers busy. The current design sports two torpedo tubes for anti-ship duty, but plans exist to upgrade the ship to mount a small spinal laser. Ships of this class are named after famous pirates, privateers, seafarers or raiders.

Options: +5 TV: Replace Drone Bay with Laser (Arc Spinal, Range 30/60, Acc 0/-1, Dam 12/10 E, Sw2)

CARRIER: VALIANT STRIKE CARRIER

Designed for long-range patrols and raids, the swift Valiant-class strike carriers have become the backbone of the Jovian fleet. A Valiant is a combination of battlecruiser and carrier, equipped with extensive internal repair bays that allow it to tend to several ships' worth of exo-armors and fighters. It also sports enormous firepower, including the first generation spinal laser that is now common on many of the largest Jovian ships. Valiant-class carriers are all named with words beginning with the letter "v."

CARRIER: FORGE PATROL CARRIER

The Forge-class carriers are some of the most common ships in the JAF, despite the carrier's mediocre armament and protection. The Forget is ideal, however, for long-range patrols in non-critical areas of the Confederation, and its complement of six exo-armors or fighters is usually more than adequate protection. The Forge is currently seeing increased production, signaling a move on the part of the JAF toward expanding its sphere of influence. It is estimated that by the year 2225, there will be more Forges in space than any other Jovian warship. Ships of the Forge class all have names beginning with the letter "f."

Options: +10 TV: Replace Railgun with Particle Beam (Range 20/40, Acc -1/-2, Dam 12E, H)

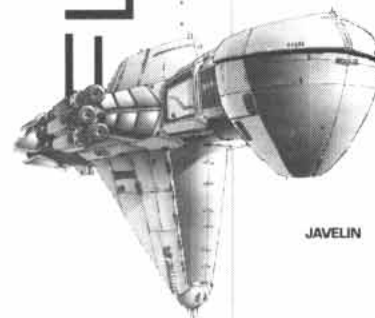

JAVELIN

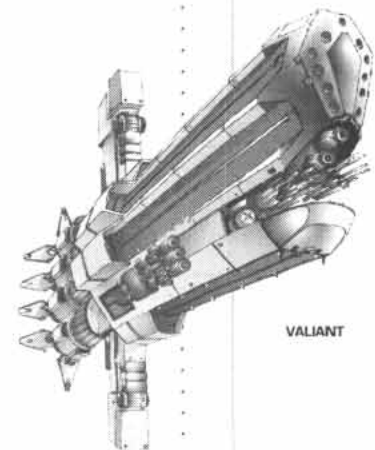

VALIANT

CARRIER: INTREPID TRANSPORT

The Intrepid-class battlefield transport is roughly analogous to the armored personnel carriers used by terrestrial infantry, carrying a flight of fighters or exo-armors to a battle zone and providing light fire support. These ships are not technically carriers, however; they possess no catapults and have no repair capabilities. In fleet operations, they are used to provide extra storage space and exo-armor transport for missions not important enough to warrant the attention of the main battle carriers; they are effectively "taxis" for other ships' complements. The basic design has been in service with the JAF since 2150.

HEAVY SHIP: GODSFIRE COMMAND CARRIER

The Godsfire class of warships has undergone remarkable change since its inception. Originally designed as a battleship class, the ships of this class were refitted in 2210 to serve as heavy carriers. The recent advent of larger, less costly carriers such as the Ypres and the Majestic, however, seems to portend the imminent demise of the design. Still, the Godsfire strikes a chord with many of the senior members of both the JAF and the Agora, and plans are in the works to evolve the design once again. The next phase of this awesome ship's lifecycle will see it as a dedicated command and control cruiser, equipped with some of the most powerful communications, electronic warfare and tactical evaluation systems ever flown aboard a single ship. Only four Godsfires have been built, one of which was destroyed in the Battle of Kurtzenheim.

Options: +20 TV: Replace Missile Bay with Drone Bay (Drones I-III, Rate 3, Reload 1)

-15 TV: Remove Com Array, Particle Beam becomes component #3.

HEAVY SHIP: YPRES BATTLESHIP

The Ypres was launched in 2212 and is essentially a moving platform for many, many guns. It carries no daughtercraft, is completely incapable of coordinating fleet activities, and is completely useless if there are no targets for it to shoot at. However, it fulfills its basic purpose superlatively, able to generate a withering hail of gunfire that can obliterate virtually any naval opponent. The ship mounts eight KKC batteries that are augmented by missile bays and heavy particle accelerators. By far its most feared system, however, is its pair of massive spinal lasers powered directly from the ship's oversized reactors and capable of alternating fire almost continuously.

HEAVY SHIP: MAJESTIC FLEET CARRIER

Even rarer than the Ypres battleships are the leviathan Majestic carriers, which are the largest combat ships in existence and are arguably the most powerful. Twenty-four exo-armors or fighters can reside within the Majestic's bays, and it also sports battleship-sized weapons, including the same spinal lasers found on the Ypres. Unfortunately, the ship requires near-constant attention from support and supply vehicles. Seven of these ships currently exist, with more on the way — another indication that Jupiter is getting ready for battle in the Inner Solar System.

SUPPORT SHIP: LENNOX CARGO SHIP

The inherent vulnerability of civilian cargo ships makes military cargo vessels like the Lennox vital to Jovian fleet operations. While totally unarmed, the Lennox is reasonably armored and possesses sufficiently powerful drives to allow it to move with the main force of the fleet. Lennox cargo ships also operate alone, generally equipped with a few flights of fighters or exo-armors for defense. The oversized habitat ring of the Lennox can serve as a medical facility in rescue and recovery operations.

SUPPORT SHIP: GAGARIN FLEET TENDER

The largest ship in service with the JAF, the Gagarin-class fleet tenders are designed to solve the logistical problem created by the vast distance between Jupiter and its enemies. Essentially a mobile shipyard, the Gagarin is slow, poorly armed, and difficult to hide. Without it, however, no Jovian fleet could operate in the Inner Solar System for an appreciable amount of time without resorting to potentially unreliable neutral assets. The Gagarin features a cavernous internal bay that is large enough to contain any ship short of a battleship, and it can be pressurized if necessary to provide an enclosed work area suitable for a complete overhaul.

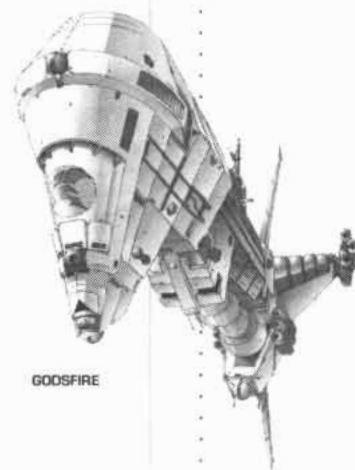

GODSFIRE

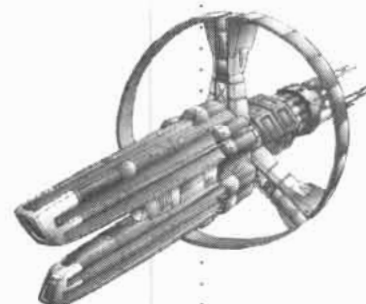

MAJESTIC

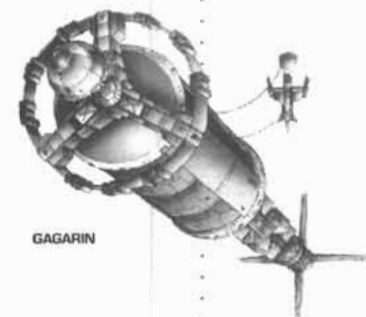

GAGARIN

COMMAND UNIT: EAL-04A PATHFINDER COMMAND

The officer's variant of the Pathfinder improves the trooper version's already-powerful sensor and communications suite. It also mounts a more powerful Jovian Optics 792R particle cannon in place of the standard 652A gun. This exo-armor is the command unit preferred by officers attached to Gamma Division. Alpha and Beta Division officers prefer the Hector, however.

Options: Exchange Hvy. Particle Cannon for Retaliator Railgun: +1 TV; Vindicator Massdriver: +3 TV; Pathfinder Sniper Railgun: +5 TV

COMMAND UNIT: EAL-04NA HECTOR

The Hector originated in the Trojan State of Newhome as a local variant of the Pathfinder but has since been adopted by the entire Confederation. The Hector performs many of the same missions but often better, since it is a machine built solely for use in space. Alpha and Beta Division officers prefer the Hector over the Pathfinder Command, which is used by Gamma Division officers. In Alpha Division, the Hector is called the Achilles.

Options: Exchange Particle Cannon for Pathfinder Command Hvy Particle Cannon: +1 TV; Retaliator Railgun: +2 TV; Vindicator Massdriver: +4 TV; Pathfinder Sniper Railgun: +6 TV

SPECIAL-DUTY UNIT: EAH-01A VINDICATOR

One of the heaviest exo-armors in the Confederation's inventory, the mighty Vindicator is moving from being an elite machine to a basic frontline support unit. This change in status (brought about by mass production and newer, better designs as well as by the increased threat of open warfare) has not diminished its effectiveness in any way. At present, however, it remains a relatively uncommon machine.

Options: Exchange Massdriver for: Pathfinder C Hvy Particle Cannon: -2 TV; Retaliator Railgun: -1 TV; Pathfinder Sniper Railgun: +4 TV, Pathfinder Particle Cannon: -3 TV

SPECIAL-DUTY UNIT: EAL-04A PATHFINDER SNIPER

The Pathfinder Sniper is a machine with a single purpose: the elimination of enemy forces from a distance. It replaces most of the standard Pathfinder's weapons and electronics with a single long-barreled massdriver with specialized sighting equipment. Although less well protected than its CEGA counterpart, the Cerberus, the Pathfinder Sniper is quicker and more maneuverable than the latter, and it has a longer reach.

SPECIAL-DUTY UNIT: IM-05 INTRUDER

First introduced in 2195, the Intruder has remained in service with the JAF as a highly specialized support fighter. Intruders are assigned to squadrons singly or in pairs, never in groups on their own. When supporting other units, the Intruder can use its stealthy characteristics to elude detection until it has achieved a superior position on the battlefield.

SPECIAL-DUTY UNIT: EAT-02 MENTOR

The JAF's primary exo-armor training vehicle can also serve as a competent field unit. Modular and easy to repair, the Mentor is capable of fulfilling most general-purpose roles. The Mentor has two full cockpits: the instructor's seat serves as a gunner/operations position, doubling the Mentor's ability to perform multiple simultaneous tasks. A variant, the Sensei, provides fire support capabilities.

Options: Exchange Particle Cannon for Retaliator Railgun: +2 TV. Add Beam Cannon (FF, Range 20/40, Acc -2/-1, Dam 5E/4E) +3 TV

ELITE UNIT: EAH-07 STORMRIDER

The Prometheus Project heralded the fourth generation of exo-armor design. Jovian Armor Works, the principal exo-armor contractor for the JAF, developed multiple prototypes of the new generation in the years since the Project's inception; the last design to leave the Project's doors was the Stormrider, a mish-mash of all the lessons learned by the Prometheus teams in the course of their marathon of exo-design innovation. Reserved almost exclusively for aces and high-ranking officers, the Stormrider requires special bay accommodations on its carrier as well as nearly triple the fuel, ammunition and downtime of more common trooper units. Originally slated for full incorporation into the JAF by the end of 2215, the production schedule has been advanced by six to twelve months in anticipation of renewed hostilities between CEGA and the Confederation.



HECTOR

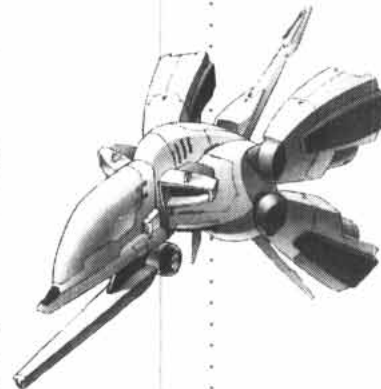

INTRUDER

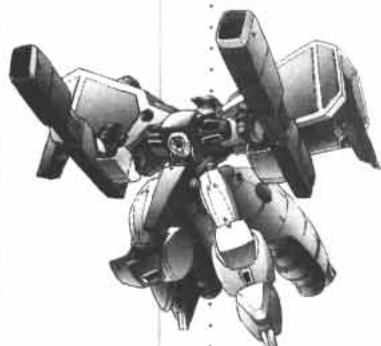

STORMRIDER



▼ JAF FLEET LIST

Line Ships:	any number of these vessels may be included in a fleet.
Carriers:	any number of these vessels may be included in a fleet. A Jovian fleet must have at least one carrier for every four line ships.
Heavy Ships:	For every eight line ships, a Jovian fleet may include one heavy ship.
Support Ships:	A Jovian fleet may have any number of Ebiiru, Lennox or Inari-class ships. A Jovian fleet may have a maximum of one Gagarin no matter how many ships it has.
Basic Units:	A Jovian fleet may have any number of basic units.
Command Units:	A Jovian fleet may have one command unit without restrictions. An additional command unit may be taken for every five basic units in the fleet.
Special-Duty Units:	A Jovian fleet may have one Pathfinder Sniper or Intruder for every six basic units. A Jovian fleet may have one Vindicator or Mentor for every three basic units.
Elite Units:	A Jovian fleet may have one elite unit. An additional elite unit may be taken for every fifteen standard units in the fleet.

◇ GROUP DEFINITIONS

Any number or type of standard units, from one to eight units, may constitute a Group. These Groups must be defined before play and must be clearly marked to prevent ambiguity. At the cost of one Action, a unit may be removed from one Group and added to another; this change must always be clearly announced. Moving to an unactivated Group does not allow the unit to act again that turn.

Jovian Armed Forces ships are used to autonomy. They do not form Groups, and thus never get bonuses for combining attacks.

◇ MORALE

The soldiers of the JAF are skilled and enthusiastic, but they are also inexperienced and easily shaken. Whenever a unit in a Group is destroyed, the remainder of the Group must make a single skill test; use the highest Skill Level in the Group, and roll against their Base Morale Threshold of 3. Add one to the roll for every command unit in the Group. If the roll succeeds, there are no adverse effects. If the roll fails, all remaining units in the Group gain a Morale counter. Any unit that has one or more Morale counters at the start of its activation must exchange one of the Morale counters for an Overthrust or Evasion counter.

◇ EQUIPMENT AVAILABILITY

COMMON EQUIPMENT:	
Standard Units:	Swarmlers, All Missiles, HARM, Assault Railgun, Sentry Pod, Melee Weapons, Anti-Missile System, Target Designator, Ablative Armor, Shield, Booster Pack
Exo-Suits:	Claymores, Booster Packs, Shields, Target Designator
Ships:	HEAT-Resistant Armor, Decoy Pod, Diogenes System, Repair Bots
RESTRICTED EQUIPMENT:	
Standard Units:	All Drone Racks, Beam Cannon, EW Pod, Snoopy Pod, Battle Arms, Vernier Module
Exo-Suits:	Toolkits
Ships:	EW Rig
EXPERIMENTAL EQUIPMENT:	
Excutor Copilot, Advanced Fire Control, Proximity Mines	

CEGA ▼

The destruction of Earth's civilization and ecosystem that came to be known as the Fall began in the late 2070s and culminated in the Third World War during the first two decades of the 22nd century. A deathly silence hung over the planet until the Unification Wars of the 2160s and 2170s. The final Unification War, in which the North American Alliance and the United States of Europe attacked several other fledgling nations, ended in armistice in 2183. The Central Earth Government and Administration, CEGA, was officially formed on January 1, 2184, and the Orbital Colonies joined shortly thereafter. By the end of the year, the entire Solar System was familiar with CEGA, which demanded a full planetary-level seat on the United Solar Nations council despite the fact that roughly half of Earth still refused to join the alliance.



Today, CEGA has three major concerns. First is its relationship with the Jovian Confederation, which many citizens of CEGA view as the ultimate rebellion against the natural order of the Homeworld: a nation of wealth and luxury built using people and resources stolen from Earth during the Fall. Second is CEGA's relationship with the rest of Earth; with its overall goal of uniting the entire Solar System under its wings, the resistance of local Earth governments is particularly galling. Finally, though many outside of CEGA often fail to realize it, CEGA is striving to rebuild, restore and heal the shattered ecosystems destroyed during the Fall.

The Odyssey rattled CEGA's core nations, who saw that CEGA had taken on an existence of its own and could operate without their direct input. Worse still, it very nearly brought Earth into a war that it was ill-prepared to fight. A series of bloody purges resulted as the NAA and the USE attempted to regain control of the monster they had created. The internal strife encouraged rebels in CEGA-occupied territories to intensify their fighting, further weakening the founding nations' influence over the meta-nation.

The Battle of Kurtzenheim had not quite the same effect on CEGA as it did on the Jovian Confederation. The citizens of CEGA were outraged at the destruction of Kurtzenheim, capital of the nation's only real ally beyond the Earth system. The events in space have demonstrated to the CEGA citizens that the colonies are incapable of handling their freedom and must be reined in with all haste. Although few members of the CEGA Assembly want war, many are preparing for the worst. Sometimes, the rod cannot be spared.

THE CEGA NAVY ▼

CEGA's military is organized into the Joint Military Service, or JMS, which comprises the CEGA Navy, the Forward Defense Armies and the Occupation Control Units. The Navy trains recruits at its academy on Goliath Station in orbit around Earth. Because CEGA troops are always well trained before entering the Service, they are seldom hindered by the anxieties their opposites in the Jovian Armed Forces frequently suffer. With the recent major military actions against the Jovian Confederation, the CEGA Navy has received increased funding for the commission of new ships of war and the refitting of older ships. The conflicts with the Jovian Confederation have demonstrated the value of small units, in particular exo-armors and exo-suits, and the Assembly has increased funding for these vehicles as well.



CEGA taskforces generally consist of numerous, relatively inexpensive warships that are most often led by a battleship-sized vessel. While Jovian warship commanders are most comfortable operating independently, CEGA commanders prefer to coordinate their actions between ships. This coordination gives CEGA warships a distinct tactical advantage, permitting the huge vehicles to operate in concert in much the same way as a squadron of fighters or exo-armors can work together. These taskforces are well suited to heavy assaults, but lack tactical maneuverability.

The Navy has six fleets, at least three of which are in the Earth system at any given time while the others patrol as far out as the Asteroid Belt, projecting the phoenix emblem of CEGA across the Inner Solar System. Each fleet is a separate entity, its commanding admiral reporting directly the JMS High Command. CEGA taskforces comprise elements from a single fleet in order to maintain overall fleet cohesiveness and to aid taskforce ship commanders in coordinating operations.

In addition to its six giant fleets, the CEGA Navy maintains three orbital squadrons dedicated to the support of planetary operations on Earth. Each of the squadrons is tasked with providing orbital assistance to an FDA (Forward Defense Army). Their low-Earth-orbit battle and reconnaissance satellites, aerospace fighters and armored space stations make the squadrons powerful formations. The orbital squadrons have few weapons capable of planetary bombardment, however; the political ramifications of using such weapons against Earth's surface keep such weapons permanently attached to the main fleets — for use against the surfaces of other planets.

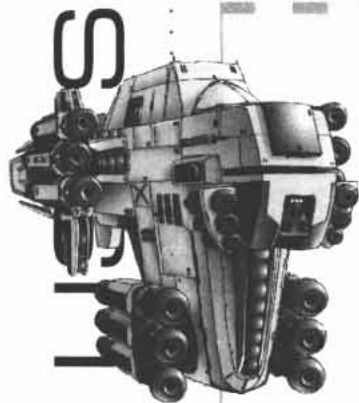

BRICRIU

LINE SHIP: BRICRIU CORVETTE

The Bricriu corvette is older than CEGA itself, dating back to 2134 when the Orbital Colonies developed it in order to defend themselves should the wars on Earth "spill over" into her surrounding space. The ship is small and cramped, and it has few crew amenities. The modern version of the Bricriu, or "Brick," as it is affectionately known, serves as a fast support craft, armed with both anti-ship and anti-fighter weaponry.

LINE SHIP: HACHIMAN DESTROYER

The Hachiman-class destroyer was once the workhorse of the CEGA Navy, and it is still seen in large numbers despite its aging design. The Hachiman's main disadvantage is its preponderance of high-signature energy weapons. Hachiman ships are thus very vulnerable to attacks and are seldom seen without an escort of fighters or corvettes. Hachiman-class ships are named after legendary warriors.

LINE SHIP: ULLER MISSILE CRUISER

Developed very early in the 2200s as a heavy support frigate, the Uller class of vessels remains relatively rare in the CEGA Navy. It relies almost exclusively on guided missile weaponry, which limits its endurance. The Uller's defining characteristic is its standard payload of eight Harpoon III heavy missiles, which are independent, self-guiding fire-and-forget weapons designed to take out capital ships with a single hit.

Options: +10 TV: Exchange both Missile Bays for 2 Drone Bay (Drones I, Rate 2, Reload 2 and Drones I-III, Rate 2, Reload 3)

LINE SHIP: CONSTANTINOPLE MAV

The Constantinople class is intended to deliver a sizable force of infantry troops to a planet or colony and to establish a "beachhead" through which a larger force can arrive. The Marine Assault Vehicle carries a complement of infantry (fifteen squads), six squads of exo-suit marines and two exo-armors, as well as the delivery vehicles required to get the troops to their destination.

Options: +0 TV: The Habitat can be modified to carry no infantry, 12 exo-suit squads and 12 Barracuda Breaching Pods.

LINE SHIP: HYDRA ADB

CEGA's initial fear of Jovian exo-armor tactics, coupled with its desire to maintain a naval force centered on warships, resulted in an initiative to create a class of small ships that could easily keep pace with enemy exo-armors. The result was the Hydra, a small, uncomfortable and somewhat structurally weak fast-attack ship able to intercept incoming attackers or pursue stragglers with equal efficiency.

LINE SHIP: CH'IN DRONE BOAT

Based on the hull of the Hydra, the Ch'in is a more versatile vessel with a correspondingly higher cost. Equipped with two large Drone bays, a Ch'in can be used as an escort carrier, an anti-ship torpedo boat, an electronic warfare unit or a minelayer; its exact function depends on the Drones carried. Because the Ch'ins require drone maintenance and repair bays, they are even more cramped than their sister ships.

CARRIER: TENGU ESCORT CARRIER

The Tengu is little more than a mobile repair bay for exo-armors and fighters. It is unable to function on its own in battle, armed only with a pair of missile bays used to provide fire support to its daughtercraft or escorts. When used properly, however, the Tengu performs its task effectively and reliably, even if its vehicle capacity is not on par with equivalent Jovian light carrier designs.

CARRIER: BIRMINGHAM ATTACK CARRIER

A concession to the undeniable power of exo-armors and fighters on the modern space battlefield, the Birmingham-class carriers are becoming a common sight in CEGA taskforces, carrying vehicles that, until recently, resided in makeshift hangars on destroyers and cruisers. A vast improvement over the cramped and undersized Tengu, the Birmingham-class ships contain full repair facilities and relatively spacious crew quarters.

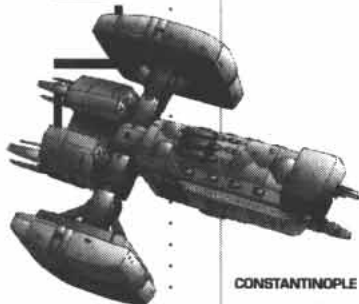

CONSTANTINOPLE

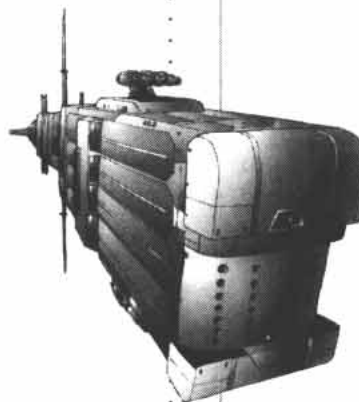

BIRMINGHAM

HEAVY SHIP: POSEIDON BATTLESHIP

Originally conceived purely as a mobile gun platform, the Poseidon-class ships were eventually finalized as battleship-carriers, having traits of both ship types. The compromises made as a result of this quick marriage of design principles are obvious. The ship's two modified cargo bays are large enough to support five exo-armors or fighters each, extensive modifications were required to rearrange the vehicle hangars in order to accommodate catapults. The vessel's armament also cannot compare to that of a dedicated battleship's weapon complement. Despite these flaws, the Poseidon is still one of the most powerful warships in the Solar System, and it is a very potent fleet command ship.

HEAVY SHIP: HAMMERHEAD DREADNOUGHT

The modern use of the term "dreadnought" is quite literal without retaining the implication of being an exceedingly large vessel. Indeed, while the Hammerhead-class ships are not nearly as large as CEGA's battleships, they have certainly been designed to be ships that need not fear any potential opponent. While most attempts to produce jack-of-all-trades ships have historically failed, CEGA's study of (and subsequent improvements to) Jovian shipbuilding methods has produced an effective, if expensive, independently operating warship. The Hammerhead shares many of the design philosophies of the Jovian Valiant and Forge classes, but without the rotating habitat that CEGA High Command considers unnecessary. Often named for marine predators, Hammerheads are amply armed with effective anti-ship weaponry, a flight of four exo-armors or fighters, and a single heavy railgun for operations against large targets.

HEAVY SHIP: NARWHAL BOMBARD

The Narwhal-class ship is one of the few space vessels that can draw and hold the attention of troops on the ground. While it can serve as an adequate battleship-sized ship of the line, the Narwhal's primary purpose is to take up position in a planet's low orbit and use its spinal railgun to destroy ground targets with little fear of retribution. A proposed variant replaces the single large railgun with a cluster of smaller weapons more suited for battlefield use, and adds an expensive and fragile targeting system to the ship's communications array.

Options: +30 TV: Exchange Railgun for Railgun Cluster (Range 20/60, Acc 0/-2, Dam 11P, AD, Sw3, PH0, R3, Con3) **and** add the following Perks to the Sensors: Con2, adds +1 to Railgun Acc when deployed.

SUPPORT SHIP: APPALACHIAN CARGO SHIP

Although CEGA makes extensive use of inconspicuous civilian cargo ships for many of its less overt operations, the CEGA Navy does maintain a sizable fleet of dedicated military cargo ships, each one larger than a battleship. Strictly non-combat vessels, Appalachian-class ships are generally unarmed, although some ships operating in known hazard areas will be assigned a flight of one or two exo-armors to protect the valuable ships from roving hunter-killer units.

SUPPORT SHIP: DETROIT FLEET SUPPORT SHIP

At first glance, a Detroit-class ship is simply an unusually large cargo ship. It has huge cargo containers and military-grade engines that allow it to keep up with a fleet accelerating at interplanetary burn. However, when a Detroit is coasting through space or orbiting a planet, its engines shut down and it reveals its true capabilities. Using advanced versions of the mobile spacedocks carried by standard cargo ships, the Detroit can deploy a repair scaffold large enough to enclose another Detroit. Although the scaffolding is fragile and cannot withstand acceleration while deployed, much less combat damage, it does greatly facilitate the repairs and service for damaged ships. A single missile bay provides defensive firepower; on some Detroits, even this paltry armament is removed.

Options: -10 TV: Remove Missile Bay

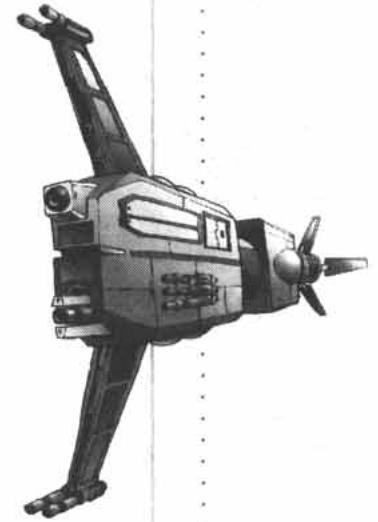

HAMMERHEAD

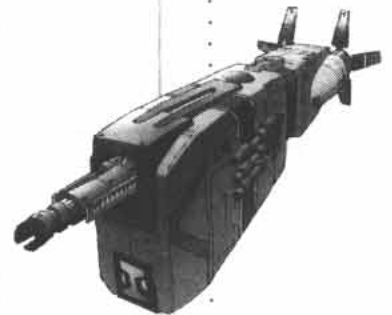

NARWHAL

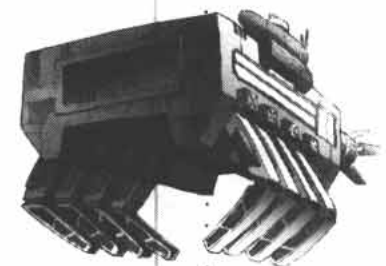

DETROIT

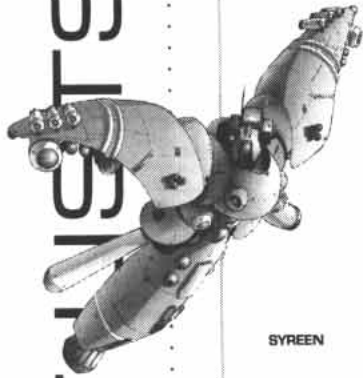

SYREEN

BASIC UNIT: CEA-01J SYREEN

Essentially a retro-fitted orbital transfer vehicle, the Syreen was merely intended to be a short-term stopgap measure. Much to nearly everyone's surprise, it has outlasted all expectations and has become CEGA's mainstay light exo-armor. While reasonably well armored, the Syreen suffers from a number of structural faults. It does have the ability to stay out of reach of its opposite in the JAF, the Pathfinder, however, which has led to the unit's popularity, both with its pilots and with CEGA's propaganda machine.

BASIC UNIT: CEA-05 WYVERN

The Wyvern is CEGA's nominal frontline exo, heavily armed and armored, but also reliable and easy to repair or replace. Equipped with an anti-missile laser system, the Wyvern is, like many CEGA units, highly resistant against missile attacks. Its hypergolic bazooka is a simple, reliable and extremely deadly weapon. The Wyvern is actually based on the Jovian Confederation's second-generation medium exo-armor, the Defender. The Marine variant adds more firepower and armor.

Options: Exchange Bazooka for: Wyvern Command Assault Massdriver +2 TV; Wyvern Bomber Rocket Pod +0 TV. Increase Protection to 7/15/21, +2 TV.

BASIC UNIT: CF-03 WRAITH

CEGA's most common spacefighter is well-respected by enemy ships, fighters and exo-armors alike. Its firepower is both versatile and powerful, with its two-person crew (one of who is a dedicated gunner), the Wraith can hit twice as hard as its Jovian counterparts. Its dual Xander X10 particle cannons, while not as powerful as those carried by Jovian exo-armors, are enough to keep enemy units occupied while it is making its bombing runs. Like most CEGA fighters, the Wraith is fully capable of operating within a planetary atmosphere.

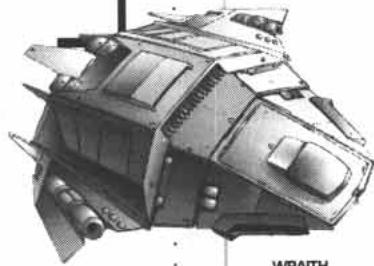

WRAITH

BASIC UNIT: CF-03 WRAITH-SI

The interceptor version of the Wraith retains the second crew member, but it dispenses with the particle cannons in favor of oversized thrusters and a large, vulcan-style massdriver cannon. The result is a simple and effective vehicle that strikes fear into almost any equivalently-sized unit on the battlefield. The Wraith-Si is just as fast as the Jovian Lancer series of fighters, but is much better armored.

BASIC UNIT: CF-08 WIGHT

The Wight is a light fighter capable of providing accurate reconnaissance and targeting data to shipboard weapons systems, allowing them to hit targets that are normally too small or too nimble for the ship-based weapons to track. Aside from its target designator, however, the Wight is lightly armed with only a single massdriver mounted to its fuselage. With its ability to operate inside a planetary atmosphere, the Wight is often used to provide on-site terminal guidance for orbit-delivered munitions.

BASIC UNIT: CM-11 BARRACUDA

The CM-11 Barracuda is the direct descendent of the CM-07 Piranha assault pod, which is a small vehicle designed to transport a squad of infantry to a space station or ship, clamp onto the hull, burn an entry hole, and disgorge its cargo into the enemy facility. The Barracuda is a larger robot-controlled boat designed to deliver a full squad of exo-suits into the enemy facility. Most Constantinople-class marine assault ships carry enough Barracudas to transport their entire exo-suit complement into battle. The Barracuda can also be fitted with a disposable reentry package that allows it to serve as a single-use shock-attack dropship.

BASIC UNIT: CS-04 MINOTAUR

The Minotaur has been in service with the CEGA Navy for nearly two decades, and it can still be found patrolling the corridors of most ships and guarding almost every space station within Earth's influence. It is so common, in fact, that most older CEGA ships and installations feature oversized corridors to allow the bulky unit to operate relatively unimpeded within their confines. Although the Minotaur is better suited to space combat than it is to ground-based operations, it still cannot compare to the Jovians' Falconer exo-suit in terms of acceleration and maneuverability.

Options: Exchange Heavy Rifles for Kobalt Masers +0 TV.

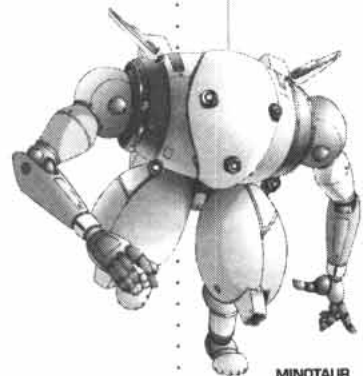

MINOTAUR

BASIC UNIT: CS-08 KOBALT

Lighter and less well-armored than the Minotaur, the Kobalt is a relatively new exo-suit designed more for close-quarters combat aboard ships and on the ground than for space fighting. Equipped with masers to minimize damage to warship components during defensive boarding operations, a squad of Kobalts is often the first thing an enemy boarding party sees upon entering a modern CEGA ship. It is certainly well on its way toward replacing the Minotaur in this duty.

Options: Exchange Masers for Minotaur Heavy Rifles +0 TV.

COMMAND UNIT: CEA-05 WYVERN COMMAND

The command variant of the Wyvern is a simple modification that exchanges the Wyvern's standard military communications suite and heavy bazooka for a high-end officer's comm system and a rapid-firing massdriver assault rifle. The Wyvern Command replaced the Syreen Commander, which was phased out of the Navy immediately upon the arrival of the Wyvern base model in 2109.

Options: Exchange Assault Massdriver for: Cerberus Sniper Massdriver +4 TV; Wyvern Bomber Rocket Pod -1 TV. Increase Protection to 7/15/21, +2 TV.

COMMAND UNIT: CEA-14 FURY

An outgrowth of the Syreen, the Fury is also a space-only machine, unable to function in an atmosphere or on the ground. In its element, however, the Fury serves as a top-of-the-line multi-role unit with several easy-to-configure weapons payloads. In its Megaera configuration, which is its standard, the Fury is often preferred over the Wyvern for dogfighting and strike missions. The Fury's less-common Alecto configuration is designed for reconnaissance, and the somewhat slower Tisiphone configuration is designed to kill capital ships using a payload of anti-ship torpedoes. The Fury Megaera is slated to become the CEGA Navy's standard command unit within the next three years.

Options: Alecto: Exchange Railgun for Drones (II, Rate 2, Reload 3) and Electronics to +2. Tisiphone: Exchange Railgun for Drones (I, Rate 4, Reload 2), Close Combat Optimized to 3 and Avoidance to 0/-1.

SPECIAL-DUTY UNIT: CEA-09 CERBERUS

Originally conceived of as a hunter-killer exo-armor, the Cerberus has rather proven itself as an ideal support unit, able to soften up targets from behind the main battle lines or wreak havoc upon enemy communications with its complex and powerful ECM suite. Although its oversized long-range sniper massdriver is somewhat awkward to use, the deficiency is made up for by the exo-armor's exceptional protection. The machine has few weaknesses aside from its high cost and time-consuming maintenance cycle.

SPECIAL-DUTY UNIT: CEA-05 WYVERN BOMBER

Conceived with only one purpose, the Wyvern Bomber is practically defenseless against other exo-armors, but carries enough heavy anti-ship torpedoes to destroy a battleship. Often deployed in pairs against enemy ships, the Wyvern Bomber normally makes its runs accompanied by a flight of standard Wyverns or Syreens for protection against enemy exo-armors and fighters.

Options: Exchange Rocket Pod for: Wyvern Bazooka +0 TV. Increase Protection to 7/15/21, +2 TV.

ELITE UNIT: CEA-21 DRAGONSTRIKER

One of the largest and most heavily armored exo-armors in production, the Dragonstriker is being delivered to selected elite squadrons in the CEGA Navy after an extended gestation period in which several prototypes were designed and redesigned. The problems with production lay not in red tape or financial matters, but rather in the simple inability of test squadrons to keep the maintenance-hungry unit operational in the field. Full-production units have been operating as far out as the middle Belt recently, however, signifying that CEGA has worked out its technical problems and now fields and unparalleled heavy assault exo-armor.

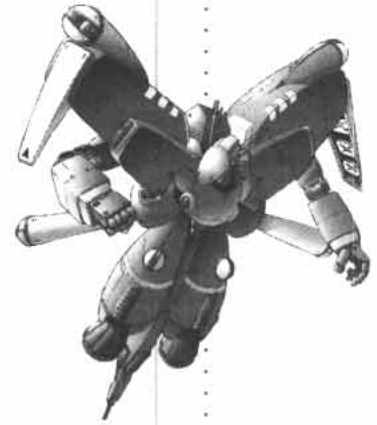

FURY

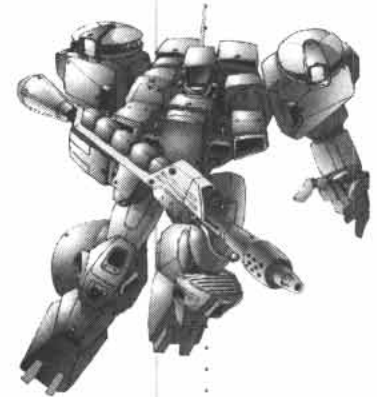

CERBERUS

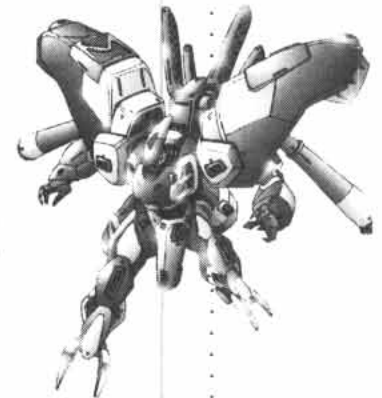

DRAGONSTRIKER



▼ CEGA NAVY FLEET LIST

Line Ships:	any number of these vessels may be included in a fleet.
Carriers:	A CEGA fleet may have one carrier for every two line ships.
Heavy Ships:	A CEGA fleet may have one heavy ship for every three line ships.
Support Ships:	A CEGA fleet may have any number of Ebiru, Appelachian or Inari-class ships. It may have a maximum of two Detroits no matter how many ships it has.
Basic Units:	A CEGA fleet may have any number of basic units.
Command Units:	A CEGA fleet may have one command unit for every six basic units.
Special-Duty Units:	A CEGA fleet may have one special-duty unit for every six basic units.
Elite Units:	A CEGA fleet may have one elite unit. An additional elite unit may be taken for every twenty standard units in the fleet.

◇ GROUP DEFINITIONS

Four to six standard units make up a Group. There are three kinds of Groups, divided by the type of unit they must be made up of: exo-armor, fighter exo-suit. A unit of one type may not be in a Group with a unit of another type. Groups may start the battle with less than four units only if there are not enough units to be evenly divisible by four; basic units may not start the game ungrouped. Units may not change which Group they are in during a battle.

Command units operate singly, or can start the game added to a Group of basic units. The command unit is considered part of the Group for all intents and purposes. Only one command unit can be attached to any one Group; the maximum number of units in a Group with an attached command unit is seven. A Group with an attached command unit gains an additional +1 attack roll bonus in any combination attack that the command unit is involved in. Special Duty units operate either singly or in Groups of two. Elite units operate alone.

CEGA is known for its mastery of fleet maneuvering. Any CEGA ships can be Grouped together. Such a Group may consist of two to four ships. A Group of ships can use combination attacks. At the cost of one action, a ship may be removed from one group and added to another; this change must always be clearly announced, and does not take effect until the End Phase. Moving to an unactivated Group does not allow the unit to act again that turn. A ship that changes Groups may not participate in any combination attacks on that turn, although it may still attack normally, without a combination bonus.

◇ MORALE

CEGA troops are, generally speaking, uncreative and stubborn. Willing to grimly stand their ground in the face of horrific losses, they inspire both awe and exasperation in their opponents. When a Group is reduced to a single unit, or if the Group's command unit is destroyed, or if a ship in a Group of ships is destroyed, the Group must make a Skill test (using the highest Skill Level in the Group) against CEGA's Base Morale Threshold of 5. If the roll succeeds, there are no adverse effects. If the roll fails, the Group gains a number of Morale counters equal to the Margin of Failure. The Player may choose which units are affected; a unit may have more than one Morale counter placed on it. Standard units that have one or more Morale counters at the start of their activation must exchange one of the Morale counters for an Overthrust or Evasion counter. A ship with Morale counters has a cumulative -1 to all its dice rolls for each Morale counter it has; the ship may spend one Action to remove one Morale counter.

◇ EQUIPMENT AVAILABILITY

COMMON EQUIPMENT:	
Standard Units:	Swarmers, All Missiles, HARM, Assault Railgun, Melee Weapons, Anti-Missile System, Target Designator, Ablative Armor, Shield, Booster Pack, EW Pod
Exo-Suits:	Claymores, Booster Packs, Shields, Target Designator
Ships:	HEAT-Resistant Armor, Decoy Pod, Proximity Mines
RESTRICTED EQUIPMENT:	
Standard Units:	All Drone Racks, Beam Cannon, Battle Arms, Vernier Module, Sentry Pod
Exo-Suits:	Toolkits
Ships:	EW Rig, Diogenes System, Repair Bots
EXPERIMENTAL EQUIPMENT:	
Snoopy Pod, Chameleon Refit	

VENUS ◀

Venus has been shrouded in mystery since the first early humans saw it shining brightly in the night. With the advent of human colonization and Herculean efforts to terraform the hostile planet into a second home for the human race, it remains to this day a mystery. It has been a corporate planet since the very first days of its terraforming, with private Earth-based corporations funding the project to found colonies on the planet outside the bounds of public governments. When the Fall cast the Homeworld into chaos, Venus felt secondary effects as an armada of refugee ships arrived in orbit seeking sanctuary and the corporations lost all contact with their headquarters back on Earth. During the first few months of this period, known as the Birthing, hundreds of thousands of people died from starvation and disease. Now, nearly 150 years after the tumultuous Birthing, Venus is a major Player in the fate of the human race. The fact that the true extent of Venus' reach is unknown alarms every other Solar power.



Venus is governed by its zaibatsu (corporations), which vie for control of the planet on political, economic, financial, social and, occasionally, military fronts. Each zaibatsu owns its own arcology; many hold orbital territories as well. The three largest Venusian zaibatsu are the Venusian Bank (VenusBank), Waldsen-Nishiyama Collective Technologies (W-NCT) and the Venusian Aerospace Corporation (VAC). Until recently, VenusBank dominated Venusian policy, and it wielded immense financial power over many of the other Solar Nations, especially CEGA.

Unbeknownst to the rest of the Solar System at large, VenusBank engineered most of the events of the Odyssey in 2210. Early in 2210, the Bank's board of directors initiated Operation Methuselah, a plan to secure Venus' dominance over the entire Solar System by disrupting or destroying the Bank's enemies. However, the major goals of the operation were foiled by Jovian agents during the Odyssey. Although the VenusBank board of directors attempted to conceal evidence of its involvement, VAC discovered evidence of Operation Methuselah in 2212, and brought it before the other zaibatsu. As a result of these revelations, the corporations of Venus have banded together under the auspices of the Planetary Advisory Board (PAB), which formed in the middle of 2213 with very little public explanation or fanfare. With the United Solar Nations' official recognition of the PAB as the sole voice of foreign policy for Venus, VenusBank has lost its hold on the affairs of the planet and, by extension, the rest of the Solar System. This fact does not mean that Venus can be ignored, however; as many politicians are fond of saying, "The only thing worse than knowing that a Venusian is pulling your strings is knowing that there are ten others pulling *his* strings."

COOPERATIVE VENUSIAN NAVAL ADMINISTRATION ▼

Venus' military situation is as complex as its politics are shadowy. While the Merchant Guild dominates shipping between planets, each zaibatsu maintains its own small transport fleet to handle cargo of "sensitive" nature and to service its System-wide assets. These require protection, both from foreign powers as well as rival zaibatsu intent on weakening the parent corporation's status. Thus, each zaibatsu maintains its own army and, until recently, navy. Individually, these forces are no match for a more conventional military.

In 2176, Venus formed the Home Defense Force in order to protect the planet and its colonies from concentrated aggression. The HDF served a secondary purpose as well: by presenting an obvious military force to the rest of the Solar System, the Venusian zaibatsu engaged in stealthy misdirection. Observers could focus on the HDF while the zaibatsu concentrated funding on their true forces behind the scenes. While the HDF is a viable military force, its technology is outdated compared to that of the individual zaibatsu.

With the formation of the Planetary Advisory Board, a second major military force has arisen in orbit around Venus. As a result of VenusBank's Operation Methuselah, and by mutual agreement between the corporations, zaibatsu are no longer permitted to possess a force of warships. Rather, each contributes money, hardware and personnel toward a unified space navy, the Cooperative Venusian Naval Administration (CVNA). No single Venusian faction controls this force; rather, it requires at least tacit approval from the entire PAB in order to conduct operations.

The two navies have very different kinds of troops. HDF troops, after decades of tireless and under-appreciated service, have grown accustomed to their lot in life and continue to serve Venus without reserve and without complex politics. The troops of the CVNA, on the other hand, are assigned to the navy from their corporate militaries, and they tend to find themselves caught up in the machinations of their zaibatsu all too frequently. As a result, internecine bickering within a CVNA ship can sometimes reduce its combat effectiveness to zero or worse.



STTS

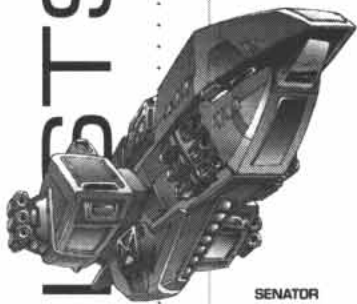

SENATOR

HDF SHIP: SENATOR CORVETTE

The Senator-class corvette is the Venusian Home Defense Force's version of the ubiquitous and reliable Bricriu warship. Venus purchased the hulls from the fledgling CEGA during the last decade of the 22nd century when the latter was particularly eager to rid itself of some of its older warships. Venus thus purchased numerous Bricrius at extremely low prices; upgrading the old Bricriu systems to the more modern Senator systems has been relatively cost-efficient, and the newer model has served the HDF well.

HDF SHIP: GAO-TZU DEFENSE CRUISER

Since 2200, the largest warships in service with the Venusian corporations were the Gao-Tzu-class defense cruisers, of which only nine were ever constructed. Given Venus' secrecy, however, it is likely that several more of these vessels exist. These ships were originally in service directly to their home corporations; the recent formation of the CVNA, however, has altered their role somewhat, and those that are awaiting conversion to the more powerful Tsar heavy cruiser configuration are assigned to the HDF.

LINE SHIP: IMPERATOR PATROL CRUISER

In Venus' incomparably crowded local space, there is a constant need for a small, nimble ship that can fulfill a variety of roles and be effective at all of them. In 2206, several corporations instituted a comprehensive refit program to take advantage of the customizability of the Senator's base hull, the Bricriu. The resulting ships, the Emperor-class patrol cruisers, are far more potent than their precursors. The Emperor uses two Bricriu hulls; one serves as a potent laser array mount and the other as a hangar for two escort vehicles.

LINE SHIP: CHIEFTAIN ESCORT CRUISER

The Chieftain-class cruiser is an exceptionally fast warship with a heavy weapons load and a small carried-craft capacity. Two boat-shaped primary hulls serve as crew quarters, while the secondary hulls are used as weapon mounts. A small bay with a pair of catapults is located in the central hull. As a class, the Chieftains exhibit more variability in appearance than any other warship class. This trait helps the ship perform its assigned duty of escorting Venusian civilian vessels to their destinations.

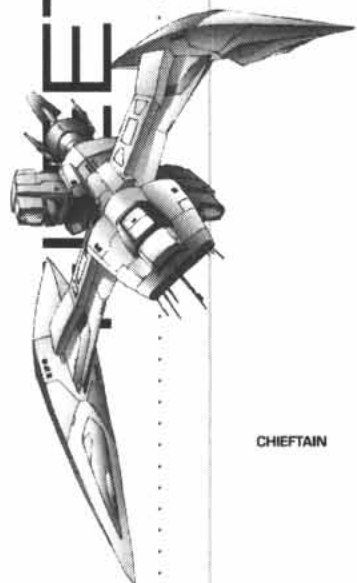

CHIEFTAIN

HEAVY SHIP: SATRAP TRANSPORT CARRIER

Most Venusian transports are essentially luxurious versions of the Ebiiru, possessing a larger main hull and a gravity wheel for crew comfort. The Satrap transport carrier is a modification of such a vessel, sacrificing some of its cargo capacity for the ability to service and launch fighters and exo-armors. Although this reasonably well-stocked fleet tender cannot fight well, it can launch swarms of daughtercraft to fight for it. In addition to traditional daughtercraft, the Satrap carries a large stock of Drones to assist in operations.

HEAVY SHIP: SHAN-YU BATTLECRUISER

The VenusBank-manufactured Shan-Yu-class battlecruiser is the largest military vessel in service with the CVNA; it is at the upper limit of size for a ship that must be disguised as a reasonably commonplace civilian ship. Although smaller than the battleships and fleet carriers of other nations, the Shan-Yu, with its heavy firepower and respectable daughtercraft complement, is more than a match for such vessels.

SPECIAL OPERATIONS SHIP: HUANG-TI OBSERVER

When the Planetary Advisory Board formed the CVNA, one of the new Navy's first projects was to design a warship capable of concealing its presence from the enemy, even at close range, to allow it to gather data unhindered by hostile attention. The Huang-Ti fills this role adequately, using as a design base the covert operations vessel that VenusBank developed for its controversial Project Methuselah. The ship does exactly what it is supposed to do but is capable of little else. Properly deployed, it is a superlative scout, but should an enemy get a lock, it is little more than an expensive coffin for its crew.

SPECIAL OPERATIONS SHIP: TSAR HEAVY CRUISER

The Tsar heavy cruiser is a recent adaptation of an older design, the Gao-Tzu defense cruiser. Replacing one of the three carrier hulls with a massive assembly housing three railguns and their associated targeting equipment, there is little doubt as to the Tsar's primary purpose: planetary bombardment. If reports are to be believed, a Tsar-class ship took part in the war between the Martian Federation and the Martian Free Republic in 2213, though the exact extent or nature of the ship's participation is unclear. Regardless, the very existence of the Tsar has alarmed both CEGA and the Jovian Confederation.

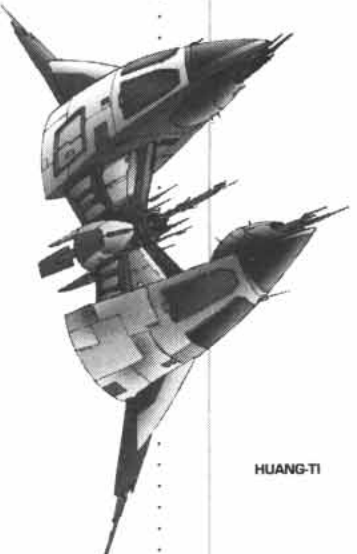

HUANG-TI

HDF UNIT: VEA-05 ONI

Although there has never been any public confirmation of rumors, it is widely believed that VenusBank provided financial, tactical and/or analytical assistance to CEGA in the development of the Wyvern exo-armor. Shortly after the initial appearance of Wyverns in CEGA's fleets, the almost identical Oni exo-armor appeared in Venus' Home Defense Force. That few Onis appeared in the private corporate armies of Venus only adds to the mystery; it is almost as though Venus used the Oni as a form of misdirection to keep prying eyes away from its real power — a hypothesis that only too well fits the planet's modus operandi.

Options: Exchange Twin Beam Cannon for: Ryu Beam Cannon +1 TV; Bonebreaker Shotgun +0 TV.

HDF UNIT: VEA-09 ER-LANG

The Er-Lang exo-armor is the result of an interesting collaboration between engineers from CEGA's Lunar Aerospace Consortium and Waldsen-Nishiyama Collective Technologies. When W-NCT delivered to the HDF three dozen Er-Lang exo-armors that were obviously relatives of CEGA's Cerberus exo-armor, a long-standing mystery was finally solved, namely the identity of the Venusian corporation that helped Earth develop its first non-derivative exo-armor. The Er-Lang of 2214 outperforms the Cerberus, suggesting that W-NCT has continued its development, something that LAC has not done with its own model.

Options: Exchange Sniper Massdriver for Oni Twin Beam Cannon -1 TV; Ryu Beam Cannon +0 TV; Bonebreaker Shotgun -1 TV.

BASIC UNIT: G-1 RYU

The Ryu is the baseline unit of every CVNA military force. It is produced by all three of the major Venusian corporations in a number of variants, and it is the most publicly recognizable of all Venusian military vehicles. Although the Oni exo-armors have been more visible thanks to their use by the HDF, the Ryu's tall and spindly profile readily captures the fancy of most citizens, unlike the rather large and chunky Oni. Despite its somewhat frail appearance, the Ryu is relatively tough and is capable of carrying a large variety of specialized equipment.

Options: Exchange Beam Cannon for Oni Twin Beam Cannon +0 TV.

BASIC UNIT: G-1 RYU BONEBREAKER

Taking an objective view of exo-vehicles' roles on the battlefield, Venusian tacticians noted that the effectiveness of an exo-unit tended to drop off sharply as its distance to its target increased. As a result of these and other observations, exo-armors in the Venusian military are generally assigned to close combat and confined-quarters fighting. The Bonebreaker is the best-known physical manifestation of this doctrine; it is designed to close quickly with an opponent or target zone and linger, fighting at very close range while receiving support from fighters.

Options: Exchange Shotguns for Oni Twin Beam Cannon +0 TV; Ryu Beam Cannon +1 TV.

BASIC UNIT: G-4 KAMINARI

Waldsen-Nishiyama Collective Technologies developed the Kaminari as a companion to the Ryu. It is the most straightforward of Venusian exo-armors, largely similar in purpose to the Jovian Vindicator. Relatively brutish in comparison to most Venusian war machines, the Kaminari is actually quite agile for its size, and it is well armored and sturdy as well. Unlike the Ryu, which has little in the way of built-in weaponry, most of the Kaminari's offensive systems are integral to the design.

BASIC UNIT: G-6 GUAN GUNG

The Guan-Gung exo-vehicle fills a role that is relatively uncommon in many militaries but that is required for the Venusians. Because much of Venus' ground is still extremely hot, most long-distance Venusian vehicles are flyers or skimmers. The Guan-Gung is, in essence, a ground-skimming armored personnel carrier designed to transport a squad of exo-suits into battle and to provide fire support for its charges. The transport can also operate in space, though it requires a simple modification to its thrusters to do so. The Guan-Gung's most distinctive characteristic is its four identical limbs.



ONI

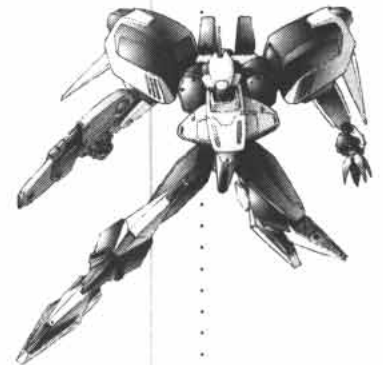

RYU

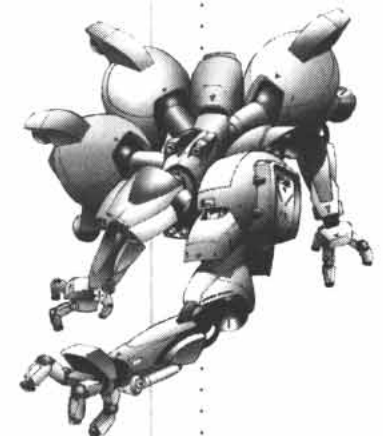

GUAN GUNG



ELECTRA

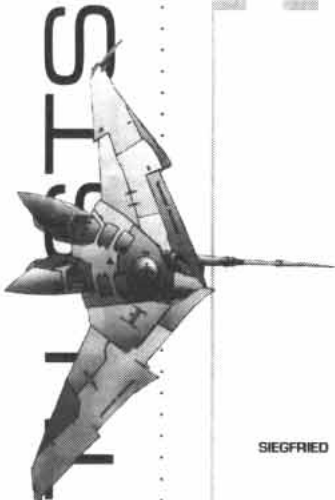

SIEGFRIED

BASIC UNIT: GF-13 SIEGFRIED

The Siegfried, while technically classified as a light fighter, is more than a match for most trooper-level exo-armors, provided its pilot remembers to stay out of arms' reach. The fighter's shape reflects the Venusian designers' desire for a visually pleasing shape with a distinctive silhouette. While in space, the craft flies with its fins in the vertical plane, but while entering or travelling through an atmosphere, the craft rolls over into a more conventional configuration. The linear frame cockpit adjusts to maintain the pilot's alignment.

BASIC UNIT: GF-09 BRUNNHILDE

The Venusians field very few dedicated atmosphere-only fighters; their winged spacefighters fill the role handily. The second notable feature of all Venusian fighters is their use of a modified linear frame as a control mechanism. The fluidity of the controls easily translates pilots' reflexes and instincts into workable combat maneuvers. The Brunnhilde, a heavy fighter, is an excellent example of both of these characteristics. The two-person craft mounts a pair of beam cannons, a tailgun laser turret and a large payload bay.

BASIC UNIT: S-2 TANUKI

The Tanuki is classified as an exo-suit but is technically the smallest exo-armor in production by any nation. Barely larger than a Martian Sabertooth exo-suit, the Tanuki is a marvel of miniaturization. The pilot operates the vehicle via a linear frame mounted in a cramped cockpit cocooned within the exo's torso. The Tanuki is the most common exo-suit used for internal security aboard CVNA ships; additionally, it is the preferred unit for boarding operations against enemy ships.

COMMAND UNIT: GG-2 SAKURA

Currently the exclusive pride and joy of Waldsen-Nishiyama Collective Technologies, the expensive Sakura exo-armor serves as a highly visible battlefield command unit for Venusian exo-armor and fighter squadrons. The Sakura is operated by three crewmembers, a pilot, a communications/drone officer and a commanding officer, although only the first two are strictly required for basic functionality. Four large payload bays carry a horde of combat drones, and each of its two arms holds a beam cannon with a plasma lance "bayonet."

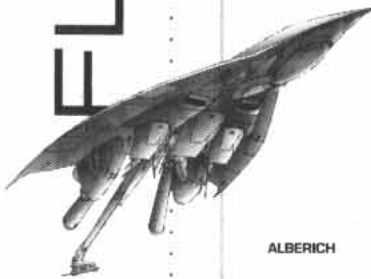

ALBERICH

SPECIAL-DUTY UNIT: GF-204 ALBERICH

Lightly armed and designed mostly to evade enemy fire, the Alberich is the perfect electronic warfare platform. Its battlefield role generally calls for it to stay on the outskirts of a fight and to use its powerful ECM/ECCM suite to take control of the battle's flow of information. Due to its nature, the Alberich is rare in the CVNA, though it is evenly distributed. A single small laser turret is mounted on a retractable boom; the laser is used for both communication and defense.

SPECIAL-DUTY UNIT: GF-115 RIENZI

The Venusians' most common dedicated anti-ship fighter, the Rienzi is equipped with enough torpedoes to overwhelm the defenses of nearly any warship. Like its smaller brethren, the fighter is capable of atmospheric flight. Although it can release its torpedoes at standoff range, doing so leaves the torpedoes vulnerable to interception and defensive fire; as a result, the Rienzi must make relatively close-approach torpedo runs. The Rienzi tends to fare poorly without an escort of additional fighters to protect it on those runs.

SPECIAL-DUTY UNIT: S-7 KITSUNE

Similar in function and size to the Jovian Decker exo-suit, the Kitsune is an extremely small and agile unit designed to operate stealthily in enclosed spaces. A recent development, the Kitsune is expensive and relatively rare, and it is assigned primarily to covert-operations vessels. The unit uses standard infantry weapons and, remarkably, is agile enough that martial artists wearing it can perform near-acrobatic moves.



KORIKAZE

ELITE UNIT: G-8 KORIKAZE

For the past two years, rumors have grown of an almost legendary "invisible" exo-armor responsible for a number of otherwise inexplicable losses and mishaps throughout the Solar System. The craft is described as a small, slender exo-armor with four arms and a pair of pulse particle guns; it uses plasma lances for close-in work. Intelligence agents have reported the existence of Venusian designs for an experimental exo-armor code-named "Korikaze" that appear to match this description. Both the Jovians and CEGA are making efforts to gain more information, but their operations are both time-consuming and expensive in terms of equipment, funding and, most notably, personnel.

CVNA FLEET LIST ▼

HDF Ships:	any number of these vessels may be included in a fleet.
Line Ships:	any number of these vessels may be included in a fleet.
Heavy Ships:	A CVNA fleet may have one Shan-Yu for every six line ships, and one Setrap without restrictions. One additional Setrap can be taken for every six line or HDF ships.
Special Operations Ships:	A CVNA fleet may have one Tsar for every three line or HDF ships, and one Huang-ti for every six line ships.
Support Ships:	A CVNA fleet may have any number of Ebiru or Inari-class ships.
HDF Units:	A CVNA fleet may have any number of Oni, and one Er-Lang for every four Oni.
Basic Units:	A CVNA fleet may have any number of basic units.
Command Units:	A CVNA fleet may have one command unit for every six basic units.
Special-Duty Units:	A CVNA fleet may have one special-duty unit for every three basic units.
Elite Unit:	A CVNA fleet may never have more than two Korikazz. Otherwise, there are no restrictions.

GROUP DEFINITIONS ◇

Four identical Basic or HDF units make up a Group. These units may have different options and add-on weapons and equipment, but the base chassis must be the same. Groups may start the battle with less than four units only if there are not enough units to be evenly divisible by four (for instance, if a force has only two Er-Lang, then the two Er-Lang will be one Group). These groups must be defined before play and must be clearly marked to prevent ambiguity. Basic and HDF units may not change which Group they are in during a battle.

Command units operate singly, or may spend one Action to join or leave a Group; such a change must always be clearly announced. Moving to an unactivated Group does not allow the unit to act again that turn. Special-Duty and elite units operate singly.

Venusian ship crews are self-serving and unwilling to divide the glory of battle with their fellows. They do not form Groups, and thus never get bonuses for combining attacks.

MORALE ◇

Made up of troops from all the Venusian corporations, the CVNA is riddled with corruption, ambition and competition. Its soldiers are determined, but far more concerned about their own skins than those of their comrades. In the End Phase of each turn, every Crippled Venusian basic or command unit and every non-HDF Venusian ship with eight or more crossed-out damage boxes must make a single Skill test against the CVNA's Base Morale Threshold of 3. If the roll succeeds, there are no adverse effects. If the rolls fails, the Venusian has decided that survival is the better part of glory, and the unit gains a Morale counter. A Venusian standard unit with a Morale counter must use either an Evasion or Overthrust counter every turn for the rest of the game. A Venusian ship with a Morale counter may only use a Fire Weapons, Ping or Electronic Warfare Action if its Avoidance is at its maximum value.

If a standard unit Fumbles its Morale roll, it is immediately destroyed; the pilot has scuttled his vehicle and ejected. Note that HDF units and ships and CVNA special-duty and elite units are not affected by Morale; special-duty pilots are handpicked veterans, and HDF units assigned to the CVNA are either too pessimistic or too ambitious to consider retreat.

EQUIPMENT AVAILABILITY ◇

COMMON EQUIPMENT:	
Standard Units:	Swarmers, All Missiles, HARM, Assault Railgun, All Drone Racks, Melee Weapons, Anti-Missile System, Target Designator, Ablative Armor, Shield, Booster Pack, EW Pod, Snoopy Pod
Exo-Suits:	Claymores, Booster Packs, Shields, Target Designator
Ships:	Decoy Pod, EW Rig, Diogenes System, Repair Bots
RESTRICTED EQUIPMENT:	
Standard Units:	Beam Cannon, Battle Arms, Vernier Module, Sentry Pod, Advanced Fire Control
Exo-Suits:	Toolkits
Ships:	HEAT-Resistant Armor, Proximity Mines
EXPERIMENTAL EQUIPMENT:	
Chameleon Refit, Executor Copilot	

▶ NEUTRAL AND INTERNATIONAL UNITS

Not everybody in the solar system is out to kill everybody else. The Mercurians, for instance, are famously neutral, unwilling to choose sides in any conflict. In the bustling inner solar system, this policy can sometime put neutral ships in very uncomfortable positions. The following guidelines assume a two-Player game. Neutral forces can also be controlled by an impartial third Player, allowing for more "realistic" behavior than the haphazard reactions described below.

Neutral forces can be used as part of a scenario. Neutral forces can also be used as "terrain" in any game, in order to simulate a battle near a colony or heavily-traveled trade route. If used in this manner, neutral units simply go about their business until attacked or damaged by one of the Players. If that happens, the other side immediately gets control of all neutral forces on the table. If both sides attack the neutrals, then control of neutral forces is randomly determined at the start of each turn.

Neutral ships will attempt to complete their missions (which usually involve fleeing the area as quickly as possible) without antagonizing anyone. If attacked, they will return fire. If prevented from leaving, they will fight to the death. Players are encouraged to come up with new motivations and responses for neutral ships, like having all neutral ships on the table randomly ping targets from both sides, or attempting to block (i.e. ram) enemy ships that get too close.

▼ COMMON SHIPS

The following ships are used by every nation in the Solar System for both military and civilian purposes. They can be purchased as part of a fleet for use as cargo and supply ships, or they may be placed on the table as neutral units, according to the guidelines above. When used as neutrals, these ships may not carry any add-on equipment. If they are chosen as part of a fleet, however, they may carry add-on equipment as allowed by that fleet's fleet list.

EBIRU CARGO SHIP

Ebiiru-class cargo ships share a sturdy and common design that dates back to the earliest phases of the commercial exploitation of space. Ships of this class are in service with virtually every settlement of the Solar System. These fusion-driven cargo vessels are used whenever a cargo needs to arrive rapidly, and cannot wait to go via one of the regular but slower solar sail flights. The external appearance of the ship is blocky and massive, with little thought given to esthetic concerns. The Ebiiru is practical above anything else, and its surface is bristling with hardpoints and tie-down rings where cargo can be attached.

INARI CARGO SHIP

Inari-class liners have a long history of reliability and endurance, having plied their trade in the solar system for more than fifty years. They have been touted as "the most efficient commercial ship in existence." Indeed, their double role as cargo and passenger liner rarely lets them leave a spaceport at less than full capacity. The spacious passenger lounges and cabins take up the whole center portion of the ship, just above engineering and the crew section. Most of the internal partitions are modular and can be quickly rearranged to fit the requirements of the passengers. Cargo is carried in two huge bays located on either side of the main hull, each having a separate life support system from the rest of the ship. The cargo bays can be detached with the help of the proper facilities and replaced by other types of bay, the most common of these being large tanks capable of holding many tons of liquefied gasses.

A few Inaris have been sold to private interests and ply the solar system as free traders, luxury cruise ships or mobile stations. Like most of these venerable transport ships, they are generally extensively modified and seldom look much like the original design. Only a close examination of the lines of the hull will allow one to recognize the ship as an Inari.

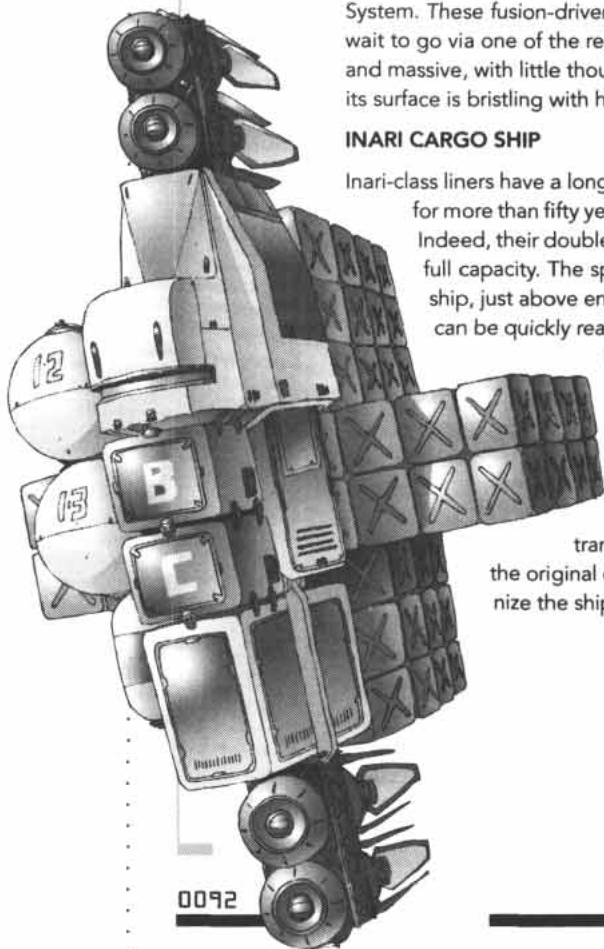

BASIC SKILLS ◀

Lieutenant Wylie Keaner looked over at his commanding officer, reporting "The exos and fighters are all back in, sir. Just a couple of escorts left."

In the command chair, Sanjay Santhakumar nodded absently. He already knew the status of the battle, but he had so far been unsuccessful in weaning Keaner from his tendency to provide constant, needless "updates." On the other hand, the new bridge Lieutenant had done an excellent gunnery job today, so perhaps there was hope for the boy in this posting, after all. In any case, Sanjay had more important things on his mind. Personal things.

She wasn't here today, he thought. That battleship wasn't the Cyclops, and she wouldn't have walked into this fight in the first place. I've been snookered.

The ship intercom chirped, signaling the return of the recovery crew to the *Venatrix*' bay. Sanjay spoke resignedly into his headset mike.

"Sergeant Grayson, did your marine team get the target?"

On the other end, Sergeant Daniel Grayson replied in clipped, professional tones. "Affirmative, sir. It's the fleet commander's pod."

Whoever it is, Sanjay thought.

"How do you know whose pod it is?" Keaner piped up. "And why do we want him, anyway?"

Grayson snorted derisively. "You're new here, aren't you, Keaner? Why don't you —"

Sanjay overrode Grayson's comment. "Cut the lip, Sergeant."

"Yessir," Grayson replied, immediately respectful. "Sorry, sir."

"No problem," Sanjay allowed. "Just remember that it's my job to make fun of the new guy."

The bridge crew's chuckles were echoed by the laughter of Grayson's commandos. Keaner reddened. Sanjay smiled. He dismissed Grayson, shut off the intercom, and turned to Keaner, studying the young officer's eager face and bright eyes.

He's part of the new breed, Sanjay thought. I never had that look on my face. Jie never had it, either. We grew out of peace, hating war. This boy was born knowing nothing but war. As a result, he can fight, but he can't understand why he needs to do so.

Sanjay sighed, wondering what sort of man Keaner would be in twenty years. He rose from his seat, and drifted toward the bridge door. At the threshold, he turned around.

"By the way, Keaner," he mused. "You haven't missed a shot yet, today, have you?"

"No, sir," Keaner replied, showing more than a hint of pride.

Sanjay activated his headset. "Spinal control," he called. "Status?"

"Ready to fire, sir," came the voice through the intercom. Sanjay nodded and grinned at Keaner.

"Keaner, you have the button for the rest of the fight. I'm going down to meet our guest." With that, he floated out of the bridge, leaving behind several crewmembers staring at one very surprised Lieutenant.

Ten meters down the bridge corridor, Sanjay felt the *Venatrix* vibrate around him as the huge spinal laser fired a full four-second shot. Sanjay didn't even pause.

Keaner has a lot of learning to do, he thought, but if nothing else, the boy certainly can shoot straight.

STANDARD PDS

•	May fire as part of a Fire Weapons Action.
•	May make one free attack on any target that enters its range during the turn.
•	Adds its Damage Multiplier as a bonus to the ship's defense rolls against Missile attacks.

SHIELD PDS

•	Automatically damages any unit that enters or leaves close combat. Damage equals PDS Damage Multiplier multiplied by Skill roll. Victim gets no defense roll.
•	Reduces the damage inflicted by "P" type hits (except attacks made in close combat) by a number of points equal to the PDS' Damage Multiplier, before the damage is multiplied by the attacker's Margin of Success.

OBSTACLES

•	Asteroids: An asteroid is in scale with the table. Asteroids block Line of Sight completely, and are the only Obstacles in LS that do so; no matter how far away two units are from each other and the asteroid, they cannot draw LOS to each other if the asteroid is between them.
•	Dust Clouds: Any ship that moves into a dust cloud may increase its Avoidance by 1. If the ship is still in the dust cloud in the End Phase, it gets another +1 to its Avoidance. Exo-armors, fighters and exo-suit squads inside a dust cloud get a +1 bonus to their defense rolls.
•	Debris Fields: Debris fields work just like dust clouds, with one addition. Units entering a debris field must make a skill check against a Threshold of 2. If the roll is failed, the unit takes a single Crippling hit to a randomly-determined system or component.
•	Rock Fields: Rock fields inflict a -2 Accuracy penalty to units attempting to fire into, out of, or through any part of the rock field. Units entering a rock field must make a Skill check against a Threshold of 2. If the roll is failed, the unit takes a single Crippling hit to a randomly-determined system or component.
•	Factory Complexes: These inflict a -2 Accuracy penalty to units attempting to fire into or through any part of the complex. They do not penalize units that are firing from inside the complex, however. Factory complexes do not have any penalties associated with entering them.

SHIP TURNING CLASSES

1)	Nimble: each turn, this ship may change facing up to one-hundred-eighty degrees at the cost of half its movement allowance.
2)	Average: each turn, this ship may change facing up to ninety degrees at the cost of half its movement allowance.
3)	Sluggish: each turn, this ship may change facing up to forty-five degrees at the cost of half its movement allowance.
4)	Immobile: this ship may not change facing at all. It either sits completely still, or moves in a single direction for the entire game.

ACTIVATION COUNTERS, STANDARD UNITS

•	Overthrust: use movement value after slash, see 2.4
•	Evasion: no actions or attacks, +3 to defense, see 3.1.1
•	Aiming: +1 to attack, -1 to defense, see 3.1.2

LAUNCHING DRONES

Rate:	the number of Drones the unit may launch each turn. Regardless of how many Drones are launched, launching Drones costs one action. For ships, Drones are launched as part of a Fire Weapons action; launching Drones does not alter a ship's Avoidance.
Reload Threshold (Standard Units):	every time the unit launches a Drone, make a Skill Roll against this Threshold. For every individual Drone launched, apply a cumulative -1 penalty to the roll. If the roll fails or fumbles, remove the unit's payload counter. No further Drones may be launched from this unit. The reload roll is made after each Drone launch, so a failed roll will not affect the Drone(s) launched this turn.
Reload Threshold (Ships):	same procedure as above, except if roll fails, mark off one damage box on Drone Bay; when damage is repaired, Drones may be launched again. Some ships have limited Drones; cross off one box for each Drone launched.

HIT LOCATION CHART

1-4	Main Hull; roll on Main Hull Damage Table
5-6	Component; roll one die and find result on target's data card

MAIN HULL DAMAGE TABLE

IF AN ALREADY-DESTROYED SYSTEM IS HIT, ATTACKER MAY CHOOSE A DIFFERENT SYSTEM.			
Die Roll:	System	Stun/Crippling Damage	Overkill Damage
1	Damage Control	Damage Control rating is halved, rounding up, until the damage is completely repaired.	Damage Control destroyed. No further damage control rolls may be made.
2	Reactor/Power	Number of actions is halved, rounding up, until the damage is completely repaired.	Number of actions drops to 1. Every End Phase, roll for Catastrophic Damage
3	Command and Control	Crew Level halved, rounding up, until the damage is completely repaired (i.e. replacement crew arrives at battlestations).	Crew Level drops to 1, any Skill Bonus is lost.
4	Electronics	Electronics Rating drops to -2 until damage is completely repaired.	Electronics is -2 permanently. All spoof attempts roll half the normal dice (round down).
5	Structure	Turning Type drops one level until the damage is completely repaired.	Whenever ship changes facing, roll one die. On a 4, 5, or 6, the ship breaks apart and is destroyed.
6	Radiation Shielding	Base Avoidance reduced by 2 per damage box until repaired.	Base Avoidance reduced to -2, permanently.

COMPONENT DAMAGE TABLE

Component	Stun/Crippling Damage	Overkill Damage
Drives	The ship's Thrust value is halved (round up) until repaired.	The ship may no longer apply thrust, nor may it change facing.
Hangar	The hangar is out of commission until it is completely repaired. All units inside the hangar are Crippled.	The hangar is destroyed, and may no longer launch, repair or recover units. All units inside the hangar are destroyed.
Cargo	20 points of cargo are destroyed (attacker chooses) for each damage box marked off. No repairs are possible.	All cargo is destroyed.
Weapon	The weapon is taken off-line for repair. It may not fire until completely repaired.	The weapon is destroyed and may not be repaired.
PDS	The PDS system's Damage Multiplier is halved (round up) until it is completely repaired.	The PDS system is destroyed and may not be repaired.

If an already-destroyed component is hit, attacker may choose a different system.

SHIP AVOIDANCE CHANGES

1)	Thrust: -1 Avoidance each time the ship applies thrust
2)	Each Ping attempt results in -1 to the ship's Avoidance. If a ship is the target of a successful ping, it gets -2 to its Avoidance.
3)	Spoof: every successful spoof attempt adds the roll's Margin of Success to the ship's Avoidance.
4)	Weapons: -1 Avoidance for each shot from any weapon (unless it has the Stealthy characteristic, see 6.2.1).
5)	Tagging: if a ship is tagged by an enemy exo-armor, fighter or exo-suit squad, it gets -1 to its Avoidance. See 6.4.
6)	Cover: every time a ship enters a dust cloud, debris field or other cover, it gets +1 to its Avoidance. In the End Phase, every ship that is hidden from all enemies by an obstacle or ship or is still in a dust cloud, debris field or other cover gets +1 to its Avoidance. See 4.4.
A ship's Avoidance may never drop below -5. See 2.6.5.	
A ship's Avoidance may never go above its Base Avoidance.	

JOVIAN CHRONICLES LIGHTNING STRIKE

Copyright ©2000 Dream Pod 9, Inc. Jovian Chronicles and Lightning Strike are trademarks of Dream Pod 9, Inc. All Rights Reserved. Tables may be photocopied for personal use.

► FULL TURN SEQUENCE

INITIATIVE PHASE	Roll Initiative
•	Players assign PDS mode for all ships
•	Move all ships with vector counters
FIRST SHIP PHASE	Players alternate moving independent (ungrouped) ships.
•	Players alternate moving Groups of ships.
•	Players alternate moving any independent ships that did not move before the Grouped units.
MAIN PHASE	Players alternate taking Actions with independent (ungrouped) standard units.
•	Players alternate taking Actions with all standard-unit Groups.
•	Players alternate taking Actions with any independent units that did not act before the Grouped units.
FOR EACH UNIT:	- Place or remove Overthrust counters before movement or Actions.
•	- Move and/or take Action(s)
SECOND SHIP PHASE	Players alternate taking Actions with independent (ungrouped) ships.
•	Players alternate taking Actions with ships.
•	Players alternate taking Actions with any independent ships that did not act before the Grouped units.
END PHASE	Resolve Grapples
•	Resolve warship missile launches.
•	Resolve warship missile hits.
•	Warships in cover get +1 to Avoidance
•	Roll for catastrophic damage on warships.

► STANDARD UNIT ACTIONS

•	Attack once with one weapon (certain weapons may attack more than once with a single action, however)
•	Remove a Stunned counter from the unit
•	Activate or Maintain ECM/ECCM
•	Leave or land on a ship
•	Tag Ship

► SHIP ACTIONS

1)	Thrust: The ship may use its normal movement allowance. This action may only be taken once per turn.
2)	Damage Control: The ship may immediately roll its full available damage control dice complement, against a Threshold of 3. The Margin of Success of the Roll is the number of damage boxes that may be repaired.
3)	Spoof: Make a Skill test using the ship's Crew Level (usually two dice with no modifiers), against a Threshold of 3. If the roll succeeds, increase the ship's Avoidance by the roll's Margin of Success.
4)	Ping: Select a target ship. Each ship makes a Skill test, modified by its Electronics rating. If the attacker wins, the defender's Visibility is reduced by 2. No matter what the result of the roll is, the attacker's Visibility is reduced by 1. If the attacker fumbles, its Visibility is reduced by 2 instead of 1.
5)	Fire Weapons: The ship may fire any or all of its weapons.

► COMMAND POINTS: STANDARD UNITS

•	One additional action, which must be used immediately.
•	One +3 bonus to the next defense roll the unit makes.
•	One free facing change of up to 180 degrees.

► COMMAND POINTS: SHIPS

•	The ship may take one action immediately. The action may be of any type except the Thrust action, which can only be used as a normal action in the Second Ship Phase. The ship's Avoidance is affected as normal by whatever action it ends up taking.
•	The ship may immediately change facing up to the maximum arc for its Turning Type. Unlike normal movement, this "emergency move" does not affect the ship's Avoidance.
•	A ship's PDS may change mode instantly. This does not affect the ship's Avoidance.

► ATTACK ROLL SUMMARY

THE ATTACKER'S ROLL EQUALS THE ROLL OF (+SKILL) DICE MODIFIED BY:	
•	+ Attack's Accuracy
•	-3 if attacker has Overthrust counter
•	+ 1 for Aiming (if applicable)
•	+ Close Combat Optimized bonus (if applicable)
•	+ combination bonus (if applicable)
•	- 2 if firing into or through rock field or factory complex
THE TARGET'S ROLL EQUALS THE ROLL OF (+SKILL) DICE MODIFIED BY:	
•	+ Avoidance
•	+ Evasion bonus (if applicable)
•	- 1 if defender has an Aiming counter
•	+1 if inside dust cloud or debris field

DAMAGE SUMMARY ◀

TOTAL DAMAGE = MARGIN OF SUCCESS X DAMAGE MULTIPLIER	
•	If Total Damage > Stun Threshold, target is Stunned (gains Stun counter, which may be removed with an Action, or mark off one damage box)
•	If Total Damage > Crippled Threshold, target is Crippled (permanently gains Crippled counter; movement allowance and attack damage permanently halved, or mark off two damage boxes)
•	If Total Damage > Overkill Threshold, target or target component is destroyed
•	2 x Stunned = Crippled, 2 x Crippled = Overkilled

RANGE FOR TAGGING & TARGETING SHIPS ◀

ELECTRONICS RATING	RANGE	ELECTRONICS RATING	RANGE
-1 and below	5 cm	+1	30 cm
0	15 cm	+3	40 cm
+1	20 cm		

Below this range, a standard unit may tag a ship, and any unit may target individual ship components.

TAGGING SHIPS ◀

TAGGING UNIT ROLLS A SKILL TEST MODIFIED BY:	
•	Electronics rating
•	Aiming (if applicable)
•	Overthrust (if applicable)
TARGET SHIP ROLLS A SKILL TEST MODIFIED BY:	
•	Electronics rating

Any exo-armor, fighter, exo-suit squad or infantry squad may use an action to tag a warship. A unit may only tag a target that is in its primary attack arc. The tagging roll is an opposed roll between the tagging unit and the target ship.

A successful tag lowers the target's Avoidance by 1.

WEAPON CHARACTERISTICS ◀

•	Anti-Infantry (AI#): The attack gains the listed Accuracy bonus to any attacks against exo-suits or infantry. All exo-suit and infantry attacks automatically have this characteristic at a rating of 2.
•	Anti-Ship (AS#): The attack gains the listed Accuracy bonus to any attacks against any object of Size B or larger.
•	Armor Piercing (AP): The target's Protection ratings are all halved, rounding up. May not Overkill.
•	Missile (Mis): affected by Missile Defense Park and warship PDS.
•	Power-hungry (PH#): The rating is the number of weapons other than the power-hungry weapon that may be fired in one action. PDS and missile bays may fire normally.
•	Rapid Fire (RF): May make a number of additional attacks equal to the rating.
•	Slow (Slw#): The attacking unit may only use this attack if it is aiming.
•	Seek (Sk#): The rating is the number of dice added to attack rolls.
•	Stealthy (St): using the weapon does not affect the firing ship's Avoidance.
•	Armor-Destroying (AD): same as Armor Piercing, but is allowed to inflict Overkill damage.
•	Flak (Fl): when attacking ships, the weapon's maximum possible damage is Stun damage (i.e. one damage point).
•	Haywire (H): If the weapon inflicts Stun damage on a ship component, that ship's Electronics receive a point of damage. If the weapon inflicts Crippling damage, the target's Electronics receive two points of damage. If the weapon hits an exo-armor or other standard unit, any damage inflicted is automatically one level worse (i.e. Stun damage becomes Crippling damage, and Crippling damage is Overkill).
•	Ship Missiles: see 6.2.2
•	Self-destruction (SD): vehicle is destroyed when weapon is used.
•	Sweeping (Swp#): weapon may reduce its Damage by the Perk's Rating in exchange for a +1 bonus to Accuracy. This exchange may be taken any number of times, so long as the weapon has damage left to "spend."
•	Target Designator (TD): does no damage. Instead, the target's Avoidance is lowered by the Margin of Success of the attack. If the target is a standard unit, mark it with a Designation counter; its Avoidance is lowered by 2. In the End Phase, remove all designation counters from play.

★ JOVIAN CHRONICLES LIGHTNING STRIKE

Copyright ©2000 Dream Pod 9, Inc. Jovian Chronicles and Lightning Strike are trademarks of Dream Pod 9, Inc. All Rights Reserved. Tables may be photocopied for personal use.

SHIPKILLER

DRONE I



ALL FORCES

E-TRONICS: -2	SIZE: 1	FACING: Fighter			
MOVEMENT: 20	SKILL THRESHOLD: 3				
FRONT AVOIDANCE: 0	REAR AVOIDANCE: -1				
PERKS:					
ATTACKS	ARC	RANGE	ACC.	DAM.	NOTES
Warhead 'A'	FF	6	0	4P	SD,ASS,AD
or					
Warhead 'B'	FF	C/2	0	12E	SD,Mis,AS2

EXOKILLER

DRONE I



ALL FORCES

E-TRONICS: -2	SIZE: 1	FACING: Fighter			
MOVEMENT: 30	SKILL THRESHOLD: 4				
FRONT AVOIDANCE: 0	REAR AVOIDANCE: -1				
PERKS:					
ATTACKS	ARC	RANGE	ACC.	DAM.	NOTES
Warhead	T	2	+2	5P	SD

SENTRY

DRONE II



ALL FORCES

E-TRONICS: -1	SIZE: 1	FACING: Exo			
MOVEMENT: 0	SKILL THRESHOLD: 4				
FRONT AVOIDANCE: 0	REAR AVOIDANCE: 0				
PERKS:					
ATTACKS	ARC	RANGE	ACC.	DAM.	NOTES
Auto-mines	T	20	+1	4E	Mis

EW

DRONE II



ALL FORCES

E-TRONICS: 0	SIZE: 1	FACING: Fighter			
MOVEMENT: 15	SKILL THRESHOLD: 4				
FRONT AVOIDANCE: 0	REAR AVOIDANCE: -1				
PERKS: ECM (4)					
ATTACKS	ARC	RANGE	ACC.	DAM.	NOTES
None					

OBSERVER

DRONE II



ALL FORCES

E-TRONICS: +3	SIZE: 1	FACING: Fighter			
SKILL THRESHOLD: 4	MOVEMENT: 20				
FRONT AVOIDANCE: -2	REAR AVOIDANCE: -3				
PERKS: Stealth (2)					
ATTACKS	ARC	RANGE	ACC.	DAM.	NOTES
Target Des.	FF	40	0	-	TD

HUNTER KILLER

DRONE III



ALL FORCES

E-TRONICS: +2	SIZE: 1	FACING: Exo			
MOVEMENT: 15	SKILL THRESHOLD: 5				
FRONT AVOIDANCE: 0	REAR AVOIDANCE: 0				
PERKS:					
ATTACKS	ARC	RANGE	ACC.	DAM.	NOTES
Laser Cannon	FF	C/15	0	4E	-

HUNTER-RIPPER

DRONE III



ALL FORCES

E-TRONICS: +2	SIZE: 1	FACING: Exo			
MOVEMENT: 20	SKILL THRESHOLD: 4				
FRONT AVOIDANCE: +1	REAR AVOIDANCE: +1				
PERKS: Close-Combat Optimized (1)					
ATTACKS	ARC	RANGE	ACC.	DAM.	NOTES
Plasma Lance	FF	C	+1	4E	

MINEFIELD

DRONE I



ALL FORCES

E-TRONICS: 0	SIZE: 1	FACING: n/a			
MOVEMENT: 0	SKILL THRESHOLD: 7				
FRONT AVOIDANCE: +3	REAR AVOIDANCE: +3				
PERKS:					
ATTACKS	ARC	RANGE	ACC.	DAM.	NOTES
Mine	T	C	0	6E	AS1

NOISEMAKER

DRONE II



ALL FORCES

E-TRONICS: 0	SIZE: 1	FACING: n/a			
MOVEMENT: 0	SKILL THRESHOLD: 3				
FRONT AVOIDANCE: n/a	REAR AVOIDANCE: n/a				
PERKS: Invulnerable after deployment					
ATTACKS	ARC	RANGE	ACC.	DAM.	NOTES
None, see 4.7.1					



PATHFINDER

EXO-ARMOR



JOVIAN FORCES

by Dream Pod 9

TV:	8	ACTIONS:	1	SIZE:	3
E-TRONICS:	+2	MOVE:	10/20	FACING:	Exo
AVOIDANCE:	0/-1	PROTECT:	4/10/12, 4/10/12		
PERKS/FLAWS:	Close Combat (2), ECCM (4)				
ATTACKS	ARC	RANGE	ACC.	DAM.	NOTES
R Cannon	F	C/10/25	+1/+1/0	4/3/2 E	

RETALIATOR

EXO-ARMOR



JOVIAN FORCES

by Dream Pod 9

TV:	10	ACTIONS:	1	SIZE:	3
E-TRONICS:	0	MOVE:	10/15	FACING:	Exo
AVOIDANCE:	0/-1	PROTECT:	5/12/15, 5/12/15		
PERKS/FLAWS:	Close Combat (2), Exposed Fire Control				
ATTACKS	ARC	RANGE	ACC.	DAM.	NOTES
Railgun	F	C/30	+1/0	4 P	AP
Plasma Lance	F	C	+1	4 E	

MENTOR

EXO-ARMOR



JOVIAN FORCES

by Dream Pod 9

TV:	14	ACTIONS:	2	SIZE:	3
E-TRONICS:	0	MOVE:	10/15	FACING:	Exo
AVOIDANCE:	0/-1	PROTECT:	4/7/11, 4/7/11		
PERKS/FLAWS:	Close Combat (2), Missile Defense (2), ECCM (4)				
ATTACKS	ARC	RANGE	ACC.	DAM.	NOTES
R Cannon	F	C/10/25	+1/+1/0	4/3/2 E	

LANCER PLUS

FIGHTER



JOVIAN FORCES

by Dream Pod 9

TV:	8	ACTIONS:	1	SIZE:	3
E-TRONICS:	0	MOVE:	15/45	FACING:	Fighter
AVOIDANCE:	-1/-3	PROTECT:	4/6/11, 4/6/11		
PERKS/FLAWS:	ECM (3), ECCM (4), Missile Defense (2)				
ATTACKS	ARC	RANGE	ACC.	DAM.	NOTES
Light Missiles	FF	C/10/25	0/0/-1	3 E	Mis

PILUM LANCER

FIGHTER



JOVIAN FORCES

by Dream Pod 9

TV:	6	ACTIONS:	1	SIZE:	3
E-TRONICS:	0	MOVE:	15/45	FACING:	Fighter
AVOIDANCE:	-1/-3	PROTECT:	4/6/11, 4/6/11		
PERKS/FLAWS:	Missile Defense (2)				
ATTACKS	ARC	RANGE	ACC.	DAM.	NOTES
Laser Cannon	FF	C/15/30	+1/+1/0	4/3/3 E	

PEACEKEEPER

FIGHTER



JOVIAN FORCES

by Dream Pod 9

TV:	12	ACTIONS:	1	SIZE:	3
E-TRONICS:	+1	MOVE:	10/35	FACING:	Fighter
AVOIDANCE:	-1/-3	PROTECT:	6/13/16, 6/13/16		
PERKS/FLAWS:	Missile Defense (1)				
ATTACKS	ARC	RANGE	ACC.	DAM.	NOTES
Missile	FF	C/30	+1/0	4P	
T Designator	FF	C/30	0/-1	-	TD
Pulse Guns	T	C/10	0	1E	A3, R1

Note: may carry one add-on weapon.

ARCHER

FIGHTER



JOVIAN FORCES

by Dream Pod 9

TV:	13	ACTIONS:	1	SIZE:	3
E-TRONICS:	+2	MOVE:	10/30	FACING:	Fighter
AVOIDANCE:	-1/-3	PROTECT:	6/12/15, 6/12/15		
PERKS/FLAWS:	ECM (3), ECCM (3), Missile Defense (1)				
ATTACKS	ARC	RANGE	ACC.	DAM.	NOTES
Laser Cannon	FF	C/25/50	+1/0/-1	2/2/1 E	
Pulse Guns	T	C/10	0	1E	A3, R1
Drones Hill					Rate:2 Reload:2

Note: may carry one add-on weapon.

FALCONER

EXO-SUIT



JOVIAN FORCES

by Dream Pod 9

TV:	10	ACTIONS:	1	SIZE:	2
E-TRONICS:	0	MOVE:	5/10	FACING:	Exo
AVOIDANCE:	+2/+2	PROTECTION:	1/2/3, 1/2/3		
PERKS/FLAWS:	Close Combat (1), Multiple Redundancy (5), Energy Protection (2/4/6)				
ATTACKS	ARC	RANGE	ACC.	DAM.	NOTES
Assault Rifles	T	C/20	+1/0	2 P	R1, A(2)

DECKER

EXO-SUIT



JOVIAN FORCES



by Dream Pod 9

TV:	8	ACTIONS:	1	SIZE:	2
E-TRONICS:	0	MOVE:	5/10	FACING:	Exo
AVOIDANCE:	+1/+1	PROTECTION:	1/2/3, 1/2/3		
PERKS/FLAWS:	Close Combat (2), Multiple Redundancy (5)				
ATTACKS	ARC	RANGE	ACC.	DAM.	NOTES
Assault Rifles	T	C/20	+1/0	2 P	R1, A(2)
Mis. Launchers	T	C/15	-1/-1	3E	Mis. Str



PATHFINDER COMMANDER

EXO-ARMOR





JOVIAN FORCES

TV: 9 ACTIONS: 1 SIZE: 3
 E-TRONICS: +2 MOVE.: 10 / 20 FACING: Exo
 AVOIDANCE: 0/-1 PROTECT.: 4/10/12, 4/10/12
 PERKS/FLAWS: Close Combat (2), EDCM (4)
 ATTACKS ARC RANGE ACC. DAM. NOTES
 H. R Cannon F C/20/40 +1/+1/0 4/3/2 E

HECTOR

EXO-ARMOR

JOVIAN FORCES

TV: 10 ACTIONS: 1 SIZE: 3
 E-TRONICS: +2 MOVE.: 15/25 FACING: Exo
 AVOIDANCE: 0/-1 PROTECT.: 5/11/15, 3/7/9
 PERKS/FLAWS: Close Combat (2), EDCM (4),
 Missile Defense (2)
 ATTACKS ARC RANGE ACC. DAM. NOTES
 Particle Cannon F C/10/25 +1/+1/0 4/3/2 E

INTRUDER

FIGHTER





JOVIAN FORCES

TV: 15 ACTIONS: 1 SIZE: 3
 E-TRONICS: 0 MOVE.: 15/45 FACING: Fighter
 AVOIDANCE: -1/-3 PROTECTION: 3/6/9, 3/6/9
 PERKS/FLAWS: Stealth (2), Missile Defense (1)
 ATTACKS ARC RANGE ACC. DAM. NOTES
 Guiding Laser FF C/30 +1/0 3E R1
 Target Des. FF C/30 +1/0 - TD
 Pulse Gun T C/10 0 1E A3

Note: may carry one add-on weapon.

PATHFINDER SNIPER

EXO-ARMOR





JOVIAN FORCES

TV: 13 ACTIONS: 1 SIZE: 3
 E-TRONICS: +3 MOVE.: 10/20 FACING: Exo
 AVOIDANCE: 0/-1 PROTECT.: 4/10/12, 4/10/12
 PERKS/FLAWS: Close Combat (2)
 ATTACKS ARC RANGE ACC. DAM. NOTES
 Sniper Railgun F 40/80 -3/-1 4 P AP Slow
 Plasma Lance F C +1 4 E

VINDICATOR

EXO-ARMOR



JOVIAN FORCES

TV: 13 ACTIONS: 1 SIZE: 3
 E-TRONICS: 0 MOVE.: 5/15 FACING: Exo
 AVOIDANCE: 0/-1 PROTECT.: 6/15/18, 6/15/18
 PERKS/FLAWS: Close Combat (2), Missile Defense (2),
 Energy Protection (7/17/21)
 ATTACKS ARC RANGE ACC. DAM. NOTES
 H. Massdriver F C/30 +1/0 4 P R1
 Laser Cannon F C/40 +1/0 4/2 E

Note: may carry two add-on weapons.

STORMRIDER

EXO-ARMOR

JOVIAN FORCES

TV: 23 ACTIONS: 1 SIZE: 4
 E-TRONICS: +2 MOVE.: 15/25 FACING: Exo
 AVOIDANCE: 0/-1 PROTECT.: 7/17/21, 7/17/21
 PERKS/FLAWS: Close Combat (2), Missile Defense (3)
 ATTACKS ARC RANGE ACC. DAM. NOTES
 Beam Cannon F C/25/50 +1/+1/0 7/5/2 E
 Missile Pods F C/5/20 0/0/-1 6 E Me, Sk1
 Scatter Gun FF C/20 +2/+1 3 P R1

Note: may not carry any add-on weapons.

SYREEN

EXO-ARMOR





CEGA FORCES

TV: 7 ACTIONS: 1 SIZE: 3
 E-TRONICS: 0 MOVE.: 15/25 FACING: Exo
 AVOIDANCE: 0/-2 PROTECT.: 3/6/11, 3/6/11
 PERKS/FLAWS: Close Combat (1), EDCM (3)
 ATTACKS ARC RANGE ACC. DAM. NOTES
 ACDS Laser F C/15/30 +1/0/0 4/3/2 E

WYVERN

EXO-ARMOR





CEGA FORCES

TV: 11 ACTIONS: 1 SIZE: 3
 E-TRONICS: 0 MOVE.: 10/15 FACING: Exo
 AVOIDANCE: 0/-2 PROTECT.: 6/14/18, 6/14/18
 PERKS/FLAWS: Close Combat (2), Missile Defense (2)
 ATTACKS ARC RANGE ACC. DAM. NOTES
 Hyper-Bazooka F C/15/30 +1/0/-1 4 P

WRAITH

FIGHTER

CEGA FORCES

TV: 10 ACTIONS: 2 SIZE: 3
 E-TRONICS: 0 MOVE.: 10/35 FACING: Fighter
 AVOIDANCE: -1 -3 PROTECT.: 6/12/18, 6/12/18
 PERKS/FLAWS: none
 ATTACKS ARC RANGE ACC. DAM. NOTES
 R Cannon FF C/15/30 +1/0/0 3/2/1E



ATHENA

DESTROYER



JOVIAN FORCES



TV:	70	CREW LEVEL:	○○	TURN.: Avgc (90°)	○○		
SIZE:	8	ACTIONS:	4 ○○	ELECTRONICS:	0 ○○		
BASE AVOIDANCE: 2/1 ○○		DAMAGE CTRL:		2 ○○			
ROLL	COMPO.	PROTECT.	ARC	RANGE	ACC.	DAM.	NOTES
	Main Hull	15/30/45					
1	Drives	12/24/36 ○○	-	-	-	-	Thrust: 10
2	Main Laser	10/20/30 ○○	FF	30/80	-2/-3	12/10E	PH1,Sw2,R1
3	KiCs	10/20/30 ○○	FF	25/50	0/-1	4P	AR R1,R5
4	KiCs	5/10/15 ○○	T	25/50	0/-1	4P	AR R1,R5
5	Missile Bays	12/24/36 ○○	F	40	0	10E	S-Mis, R1
6	PDS	10/20/30 ○○	T	5	+1	3E	PDS

NOTES:

VEHICLE CAPACITY:	1	REPAIR:	3	FLEET MANEUVER:	2
-------------------	---	---------	---	-----------------	---

JAVELIN

MISSILE CRUISER



JOVIAN FORCES

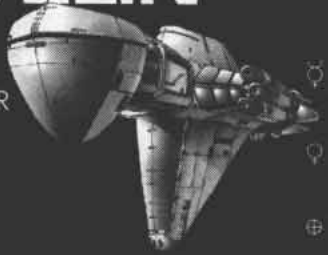

TV:	50	CREW LEVEL:	○○	TURN.: Avgc (90°)	○○		
SIZE:	8	ACTIONS:	4 ○○	ELECTRONICS:	0 ○○		
BASE AVOIDANCE: 2/1 ○○		DAMAGE CTRL:		3 ○○			
ROLL	COMPO.	PROTECT.	ARC	RANGE	ACC.	DAM.	NOTES
	Main Hull	14/28/42					
1	Drives	13/26/39 ○○	-	-	-	-	Thrust: 10
2	KiCs	5/10/15 ○○	T	25/50	0/-1	5P	AR R1,R5
3	PDS	10/20/30 ○○	T	5	+1	2E	PDS
4	Drones I	12/24/36 ○○	-	-	-	-	Rate: 2, Reload: 2
5	Missile Bay	12/24/36 ○○	F	40	0	10E	S-Mis
6	No component	-	-	-	-	-	-

NOTES:

VEHICLE CAPACITY:	1	REPAIR:	3	FLEET MANEUVER:	2
-------------------	---	---------	---	-----------------	---

THUNDERBOLT

CRUISER



JOVIAN FORCES

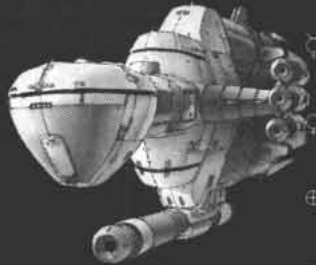

TV:	50	CREW LEVEL:	○○	TURN.: Avgc (90°)	○○		
SIZE:	8	ACTIONS:	4 ○○	ELECTRONICS:	+1 ○○		
BASE AVOIDANCE: 2/1 ○○		DAMAGE CTRL:		2 ○○			
ROLL	COMPO.	PROTECT.	ARC	RANGE	ACC.	DAM.	NOTES
	Main Hull	14/28/42					
1	Drives	13/26/39 ○○	-	-	-	-	Thrust: 10
2	Part Cannon	10/20/30 ○○	T	10/30	0/-1	7E/6E	H
3	KiCs	5/10/15 ○○	T	25/50	0/-1	5P	AR R1,R5
4	PDS	10/20/30 ○○	T	5	+1	2E	PDS
5	No component	-	-	-	-	-	-
6	No component	-	-	-	-	-	-

NOTES:

VEHICLE CAPACITY:	1	REPAIR:	3	FLEET MANEUVER:	2
-------------------	---	---------	---	-----------------	---

ALEXANDER

DESTROYER



JOVIAN FORCES

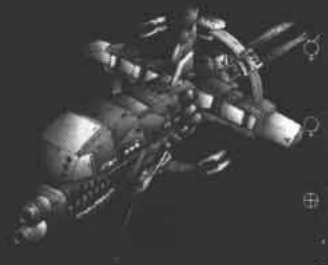

TV:	75	CREW LEVEL:	○○	TURN.: Avgc (90°)	○○		
SIZE:	8	ACTIONS:	4 ○○	ELECTRONICS:	0 ○○		
BASE AVOIDANCE: 2/1 ○○		DAMAGE CTRL:		2 ○○			
ROLL	COMPO.	PROTECT.	ARC	RANGE	ACC.	DAM.	NOTES
	Main Hull	16/32/48					
1	Drives	13/26/39 ○○	-	-	-	-	Thrust: 10
2	R Beam	12/24/36 ○○	Spr	30/80	-1/2	8E	R1,H
3	KiCs	5/10/15 ○○	T	25/50	0/-1	5P	AR R1,R5
4	Lasers	10/20/30 ○○	T	25	+1	4E	R1
5	Missile Bay	12/24/36 ○○	F	50	0	10E	S-Mis
6	PDS	10/20/30 ○○	T	5	+1	3E	PDS

NOTES:

VEHICLE CAPACITY:	1	REPAIR:	3	FLEET MANEUVER:	3
-------------------	---	---------	---	-----------------	---

CORSAIR

FRIGATE



JOVIAN FORCES



by Dream Pod 9

TV:	25	CREW LEVEL:	○○	TURN.: Nimble (180°)	○○
SIZE:	7	ACTIONS:	3 ○○	ELECTRONICS:	+1 ○○
BASE AVOIDANCE:		3/2 ○○	DAMAGE CTRL:		
		2 ○○			

ROLL	COMPO.	PROTECT.	ARC	RANGE	ACC.	DAM.	NOTES
	Main Hull	10/20/30					
1	Drives	10/20/30 ○○	-	-	-	-	Thrust: 10
3	Drones I	9/18/27 ○○	-	-	-	-	Ratr: 2, Reload: 2
5	Missile Bay	9/18/27 ○○	T	40	0	10E	S-Mis
6	POG	9/18/27 ○○	T	5	+1	2E	POG
5	No component	-	-	-	-	-	-
6	No component	-	-	-	-	-	-

NOTES:

VEHICLE CAPACITY:	1	REPAIR:	2	FLEET MANEUVER:	2
-------------------	---	---------	---	-----------------	---

VALIANT

STRIKE CARRIER



JOVIAN FORCES

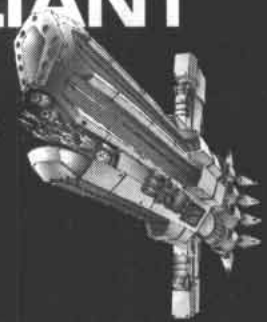

by Dream Pod 9

TV:	80	CREW LEVEL:	○○	TURN.: Sluggish (45°)	○○
SIZE:	9	ACTIONS:	5 ○○	ELECTRONICS:	+1 ○○
BASE AVOIDANCE:		2/0 ○○	DAMAGE CTRL:		
		3 ○○			

ROLL	COMPO.	PROTECT.	ARC	RANGE	ACC.	DAM.	NOTES
	Main Hull	20/40/60					
1	Drives	15/30/45 ○○	-	-	-	-	Thrust: 10
2	Hanger	10/20/30 ○○	-	-	-	-	Bays: 6 Cats: 6
3	Spinal Laser	15/30/45 ○○	Spri	30/60	0/2	16/12E	PHO, Sw2
4	KKCs	5/10/15 ○○	T	25/50	0/1	5P	AR R1, R, S
5	Missile Bay	18/36/54 ○○	F	50	0	10E	S-Mis
6	POG	10/20/30 ○○	T	5	+1	2E	POG

NOTES:

VEHICLE CAPACITY:	12	REPAIR:	4	FLEET MANEUVER:	3
-------------------	----	---------	---	-----------------	---

FORGE

PATROL CARRIER



JOVIAN FORCES



by Dream Pod 9

TV:	60	CREW LEVEL:	○○	TURN.: Avrg (90°)	○○
SIZE:	8	ACTIONS:	4 ○○	ELECTRONICS:	0 ○○
BASE AVOIDANCE:		2/1 ○○	DAMAGE CTRL:		
		2 ○○			

ROLL	COMPO.	PROTECT.	ARC	RANGE	ACC.	DAM.	NOTES
	Main Hull	13/26/38					
1	Drives	10/20/30 ○○	-	-	-	-	Thrust: 10
2	Hanger	10/20/30 ○○	-	-	-	-	Bays: 6 Cats: 6
3	Railgun	12/24/36 ○○	Spri	10/30	0/1	5P	AD, PHD
4	KKCs	5/10/15 ○○	T	25/50	0/1	5P	AR R1, R, S
5	Missile Bay	12/24/36 ○○	F	40	0	10E	S-Mis
6	POG	10/20/30 ○○	T	5	+1	2E	POG

NOTES:

VEHICLE CAPACITY:	12	REPAIR:	3	FLEET MANEUVER:	2
-------------------	----	---------	---	-----------------	---

INTREPID

TRANSPORT



JOVIAN FORCES



by Dream Pod 9

TV:	40	CREW LEVEL:	○○	TURN.: Avrg (90°)	○○
SIZE:	8	ACTIONS:	3 ○○	ELECTRONICS:	0 ○○
BASE AVOIDANCE:		3/2 ○○	DAMAGE CTRL:		
		2 ○○			

ROLL	COMPO.	PROTECT.	ARC	RANGE	ACC.	DAM.	NOTES
	Main Hull	13/26/38					
1	Drives	11/22/33 ○○	-	-	-	-	Thrust: 10
2	Hanger	13/26/38 ○○	-	-	-	-	Bays: 8
3	KKCs	5/10/15 ○○	T	25/50	0/1	4P	AR R1, R, S
4	Missile Bay	11/22/33 ○○	F	50	0	10E	S-Mis
5	POG	10/20/30 ○○	T	5	+1	2E	POG
6	No component	-	-	-	-	-	-

Notes: The Intrepid's bays may not make repairs in campaigns

Vehicle Capacity:	16	Repair:	2	Fleet Maneuver:	2
-------------------	----	---------	---	-----------------	---



GODSFIRE

COMMAND CARRIER



JOVIAN FORCES

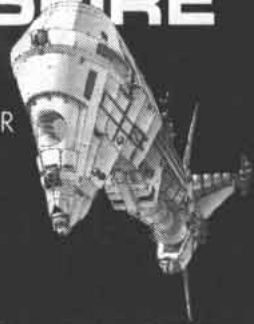

TV: 120/140 CREW LEVEL: ○○ TURN.: Sluggish (45°) ○○
 SIZE: 9 ACTIONS: 5 ○○ ELECTRONICS: +2 ○○
 BASE AVOIDANCE: 1/-1 ○○ DAMAGE CTRL: 4 ○○

ROLL	COMPO.	PROTECT.	ARC	RANGE	ACC.	DAM.	NOTES
Main Hull		20/40/60					
1	Drives	15/30/45 ○○	-	-	-	-	Thrust: 5
2	Hanger	12/24/36 ○○	-	-	-	-	Bays: 12 Cats: 4
3	Corn Array	8/16/24 ○○	-	-	-	-	ECCM (4)
4	R Beam	10/20/30 ○○	T	30/60	-1/2	BE	R1,H
4	KDCs	6/12/18 ○○	T	25/50	0/-1	5P	AR, R1
5	POG	10/20/30 ○○	T	5	+1	4E	POG
6	Missile Bay	12/24/36 ○○	F	40	0	10E	SMis

NOTES: Unless damaged, the Corn Array also gives the Jovian commander 2 extra initiative command points each turn
 VEHICLE CAPACITY: 24 REPAIR: 5 FLEET MANEUVER: 3

YPRES

BATTLESHIP



JOVIAN FORCES



TV: 135 CREW LEVEL: ○○ TURN.: Sluggish (45°) ○○
 SIZE: 9 ACTIONS: 5 ○○ ELECTRONICS: 0 ○○
 BASE AVOIDANCE: 1/-1 ○○ DAMAGE CTRL: 4 ○○

ROLL	COMPO.	PROTECT.	ARC	RANGE	ACC.	DAM.	NOTES
Main Hull		24/48/72					
1	Drives	15/30/45 ○○	-	-	-	-	Thrust: 5
2	Spiral Laser	20/40/60 ○○	Spiral	30/60	0/2	16/12E	PH1,Sw2
3	R Beam	12/24/36 ○○	T	30/60	-1/2	BE	H
4	KDCs	10/20/30 ○○	T	25/50	+1/0	5P	AR, R3,R5s
5	Missile Bays	20/40/60 ○○	F	50	0	10E	SMis, R1
6	POG	12/24/36 ○○	T	5	+1	3E	POG

NOTES:
 VEHICLE CAPACITY: 2 REPAIR: 4 FLEET MANEUVER: 2

MAJESTIC

FLEET CARRIER



JOVIAN FORCES



TV: 145 CREW LEVEL: ○○ TURN.: Sluggish (45°) ○○
 SIZE: 9 ACTIONS: 5 ○○ ELECTRONICS: 0 ○○
 BASE AVOIDANCE: 1/-1 ○○ DAMAGE CTRL: 4 ○○

ROLL	COMPO.	PROTECT.	ARC	RANGE	ACC.	DAM.	NOTES
Main Hull		20/40/60					
1	Drives	15/30/45 ○○	-	-	-	-	Thrust: 5
2	Hanger	13/26/39 ○○	-	-	-	-	Bays: 24, Cats: 12
3	Spiral Laser	18/36/54 ○○	Spiral	30/60	0/2	16/12E	PH1,Sw2
4	KDCs	7/14/21 ○○	T	25/50	0/-1	5P	AR, R3,R5s
5	Missile Bays	18/36/54 ○○	F	50	0	10E	SMis, R2
6	POG	11/22/33 ○○	T	5	+1	3E	POG

NOTES:
 VEHICLE CAPACITY: 48 REPAIR: 5 FLEET MANEUVER: 2

LENNOX

CARGO SHIP



JOVIAN FORCES



TV: 60 CREW LEVEL: ○○ TURN.: Sluggish (45°) ○○
 SIZE: 9 ACTIONS: 3 ○○ ELECTRONICS: 0 ○○
 BASE AVOIDANCE: 0/-1 ○○ DAMAGE CTRL: 2 ○○

ROLL	COMPO.	PROTECT.	ARC	RANGE	ACC.	DAM.	NOTES
Main Hull		17/34/51					
1	Drives	13/26/39 ○○	-	-	-	-	Thrust: 10
2	Hanger	13/26/39 ○○	-	-	-	-	Bays: 3
3	Cargo	16/32/48 ○○	-	-	-	-	75 Cargo Units
4	Cargo	5/10/15 ○○	-	-	-	-	75 Cargo Units
5	POG	10/20/30 ○○	T	5	+1	3E	POG
6	No component	-	-	-	-	-	-

NOTES: The Lennox' crew has -1 penalty in boarding actions.
 VEHICLE CAPACITY: 6 REPAIR: 2 FLEET MANEUVER: 2

WRAITH-SI

FIGHTER



CEGA FORCES



TV: 12 ACTIONS: 2 SIZE: 3
 E-TRONICS: 0 MOVE: 15/45 FACING: Fighter
 AVOIDANCE: -1/-3 PROTECT.: 6/12/18,6/12/18
 PERKS/FLAWS:

ATTACKS ARC RANGE ACC. DAM. NOTES
 Heavy Vulcan FF C/10/20 +1/0/0 4 / 3 P

Note: may carry one add-on weapon.

WIGHT

FIGHTER



CEGA FORCES



TV: 11 ACTIONS: 1 SIZE: 3
 E-TRONICS: +1 MOVE: 15/45 FACING: Fighter
 AVOIDANCE: 0/-2 PROTECTION: 3/7/11,3/7/11
 PERKS/FLAWS:

ATTACKS ARC RANGE ACC. DAM. NOTES
 Target Des. FF C/20/40 +1/0/1 - TD
 Massdriver FF C/20 +1/0 2P R1

MINOTAUR

EXO-SUIT



CEGA FORCES



TV: 8 ACTIONS: 1 SIZE: 2
 E-TRONICS: 0 MOVE: 5/10 FACING: Exo
 AVOIDANCE: +1/+1 PROTECTION: 2/4/6,2/4/6
 PERKS/FLAWS: Close Combat (2),
 Multiple Redundancy (5)

ATTACKS ARC RANGE ACC. DAM. NOTES
 Heavy Rifles T C/15 +1/0 2P AR A (2)

KOBALT

EXO-SUIT



CEGA FORCES



TV: 5 ACTIONS: 1 SIZE: 2
 E-TRONICS: 0 MOVE: 5/10 FACING: Exo
 AVOIDANCE: +1/+1 PROTECTION: 1/2/3, 1/2/3
 PERKS/FLAWS: Close Combat Optimized (2),
 Multiple Redundancy (5)

ATTACKS ARC RANGE ACC. DAM. NOTES
 Mass Rifles T C/15 +1 2 E R1, A (2)

COMMAND WYVERN

EXO ARMOR



CEGA FORCES



TV: 13 ACTIONS: 1 SIZE: 3
 E-TRONICS: +1 MOVE: 10/15 FACING: Exo
 AVOIDANCE: 0/-2 PROTECT.: 6/14/18, 6/14/18
 PERKS/FLAWS: Close Combat (2), Missile Defense (2)

ATTACKS ARC RANGE ACC. DAM. NOTES
 A. Massdriver F C/15/30 +1/0/1 4P R1

FURY

EXO-ARMOR



CEGA FORCES



TV: 13 ACTIONS: 1 SIZE: 3
 E-TRONICS: 0 MOVE: 15/25 FACING: Exo
 AVOIDANCE: +1/0 PROTECTION: 5/9/13,5/9/13
 PERKS/FLAWS: Close Combat (2), Missile Defense (2)

ATTACKS ARC RANGE ACC. DAM. NOTES
 Heatseekers T C/10/20 +1/+1/0 3/3/2E -
 Sniper Railgun FF 25/50 -1/0 2P AP

CERBERUS

EXO-ARMOR



CEGA FORCES



TV: 16 ACTIONS: 1 SIZE: 3
 E-TRONICS: +2 MOVE: 10/15 FACING: Exo
 PERKS/FLAWS: Close Combat (2), ECM (4), ECCM (4)
 AVOIDANCE: -1/-2 PROTECT.: 7/17/21,7/17/21

ATTACKS ARC RANGE ACC. DAM. NOTES
 S. Massdriver F 35/70 -2/-1 4P AP, Slow
 Plasma Lance F C/5 +1 4/2E

WYVERN BOMBER

EXO ARMOR



CEGA FORCES



TV: 13 ACTIONS: 1 SIZE: 3
 E-TRONICS: 0 MOVE: 10/15 FACING: Exo
 AVOIDANCE: 0/-2 PROTECT.: 6/14/18,6/14/18
 PERKS/FLAWS: Close Combat (2), Missile Defense (2)

ATTACKS ARC RANGE ACC. DAM. NOTES
 Rocket Pods F C/10 +1/0 4 E Ms, R1
 Ship Torpedoes F C/20 -2 8 E Ms, AS2

BARRACUDA

FIGHTER



CEGA FORCES



TV: 3 ACTIONS: 1 SIZE: 3
 E-TRONICS: -1 MOVE: 10/30 FACING: Fighter
 AVOIDANCE: 0/-1 PROTECT.: 7/14/21,7/14/21
 PERKS/FLAWS: Skill Threshold 2, Close Combat (1)

ATTACKS ARC RANGE ACC. DAM. NOTES
 Internal Cargo: 1x Exo-suit squad or 2x Infantry
 Plasma Cutter FF C +1 10E AP, Slow, R

Note: may not carry add-on weapons.



BRICRIU

CORVETTE



CEGA FORCES

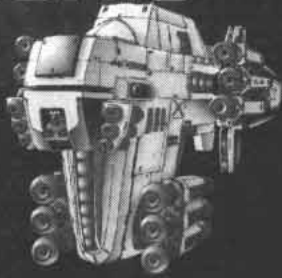

by Dream Pod 9

TV:	30 / 25	CREW LEVEL:	○○	TURN.: Nimble (180°)	○○		
SIZE:	7	ACTIONS:	3 ○○	ELECTRONICS:	0 ○○		
BASE AVOIDANCE:	3/2 ○○	DAMAGE CTRL:	2 ○○				
ROLL	COMPO.	PROTECT.	ARC	RANGE	ACC.	DAM.	NOTES
Main Hull 9/18/27							
1	Drives	8/16/24 ○○	-	-	-	-	Thrust:10
2	Lt. P Beam	7/14/21 ○○	T	20/40	0/-1	6E	R1,H
3	KKCs	5/10/15 ○○	T	25/50	0/-1	4P	AP, R1, R, S
4	POS	8/16/24 ○○	T	5	+1	2E	POS
5	No component	-	-	-	-	-	-
6	No component	-	-	-	-	-	-

NOTES:

VEHICLE CAPACITY: 1 REPAIR: 2 FLEET MANEUVER: 1

HACHIMAN

DESTROYER



CEGA FORCES



by Dream Pod 9

TV:	60	CREW LEVEL:	○○	TURN.: Average (90°)	○○		
SIZE:	8	ACTIONS:	4 ○○	ELECTRONICS:	0 ○○		
BASE AVOIDANCE:	2/1 ○○	DAMAGE CTRL:	2 ○○				
ROLL	COMPO.	PROTECT.	ARC	RANGE	ACC.	DAM.	NOTES
Main Hull 13/26/38							
1	Drives	11/22/33 ○○	-	-	-	-	Thrust:10
2	P Beam	7/14/21 ○○	T	30/60	-1/2	6E	R1,H
3	Lasers	5/10/15 ○○	T	30/60	0/-1	5E	Sw1, S
4	Missile Bay	8/16/24 ○○	F	40	0	10E	SMis, R1
5	Missile Bay	8/16/24 ○○	F	40	0	10E	SMis, R1
6	POS	10/20/30 ○○	T	5	+1	2E	POS

NOTES:

VEHICLE CAPACITY: 1 REPAIR: 2 FLEET MANEUVER: 2

ULLER

MISSILE CRUISER



CEGA FORCES

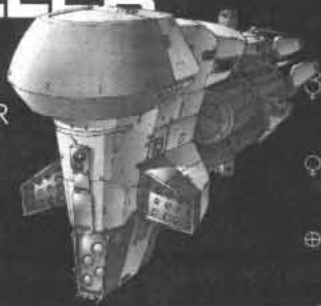

by Dream Pod 9

TV:	50	CREW LEVEL:	○○	TURN.: Average (90°)	○○		
SIZE:	8	ACTIONS:	4 ○○	ELECTRONICS:	0 ○○		
BASE AVOIDANCE:	2/1 ○○	DAMAGE CTRL:	2 ○○				
ROLL	COMPO.	PROTECT.	ARC	RANGE	ACC.	DAM.	NOTES
Main Hull 13/26/38							
1	Drives	11/22/33 ○○	-	-	-	-	Thrust:10
2	Drones I	8/16/24 ○○	-	-	-	-	Rate: 2, Reload: 2
3	Missile Bay	8/16/24 ○○	F	40	0	10E	SMis, R1
4	Missile Bay	8/16/24 ○○	F	40	0	10E	SMis, R1
5	POS	10/20/30 ○○	T	5	+1	2E	POS
6	No component	-	-	-	-	-	-

NOTES:

VEHICLE CAPACITY: 1 REPAIR: 3 FLEET MANEUVER: 2

CONSTANTINOPLE

MARINE ASSAULT SHIP



CEGA FORCES



by Dream Pod 9

TV:	70/85	CREW LEVEL:	○○	TURN.: Average (90°)	○○		
SIZE:	8	ACTIONS:	4 ○○	ELECTRONICS:	0 ○○		
BASE AVOIDANCE:	2/1 ○○	DAMAGE CTRL:	3 ○○				
ROLL	COMPO.	PROTECT.	ARC	RANGE	ACC.	DAM.	NOTES
Main Hull 15/30/45							
1	Drives	13/26/38 ○○	-	-	-	-	Thrust:10
2	Hangar	10/20/30 ○○	-	-	-	-	Bay:4 Cat:2
3	Habitat	15/30/45 ○○	-	-	-	-	-
4	KKCs	5/10/15 ○○	T	25/50	0/-1	5P	AP, R1, R, S
5	P Beam	11/22/33 ○○	FF	30/60	-1/2	6E	H
5	Missile Bay	12/24/36 ○○	F	50	0	10E	SMis
6	POS	10/20/30 ○○	T	5	+1	3E	POS

Notes: The Habitat can carry up to fifteen infantry squads and six Exo-Suit squads.

VEHICLE CAPACITY: 8 REPAIR: 2 FLEET MANEUVER: 2

HYDRA

DEFENSE BOAT



CEGA FORCES



by Dream Pod 9

TV:	30/30	CREW LEVEL:	○○	TURN.:	Nimble (90°) ○○		
SIZE:	7	ACTIONS:	2 ○○	ELECTRONICS:	0 ○○		
BASE AVOIDANCE: 3/2 ○○		DAMAGE CTRL: 2 ○○					
ROLL	COMPO.	PROTECT.	ARC	RANGE	ACC.	DAM.	NOTES
	Main Hull	9/18/27					
1	Drives	8/16/24 ○○	-	-	-	-	Thrust: 15
2	AD Laser	9/18/27 ○○	T	30	+3	2E	R3, Sw1, St
3	KKCs	4/8/12 ○○	T	25/50	0/-1	4P	APR, St
4	POS	8/16/24 ○○	T	5	+1	2E	POS
5	No component:	-	-	-	-	-	-
6	No component:	-	-	-	-	-	-

NOTES:

VEHICLE CAPACITY:	1	REPAIR:	2	FLEET MANEUVER:	0
--------------------------	---	----------------	---	------------------------	---

CHIN

DRONE BOAT



CEGA FORCES



by Dream Pod 9

TV:	30/30	CREW LEVEL:	○○	TURN.:	Nimble (90°) ○○		
SIZE:	7	ACTIONS:	2 ○○	ELECTRONICS:	0 ○○		
BASE AVOIDANCE: 3/2 ○○		DAMAGE CTRL: 2 ○○					
ROLL	COMPO.	PROTECT.	ARC	RANGE	ACC.	DAM.	NOTES
	Main Hull	9/18/27					
1	Drives	8/16/24 ○○	-	-	-	-	Thrust: 15
2	Drones Hill	9/18/27 ○○	-	-	-	-	Rate: 3, Reload: 1
3	KKCs	4/8/12 ○○	T	25/50	0/-1	4P	APR, St
4	POS	8/16/24 ○○	T	5	+1	2E	POS
5	No component:	-	-	-	-	-	-
6	No component:	-	-	-	-	-	-

NOTES:

VEHICLE CAPACITY:	1	REPAIR:	2	FLEET MANEUVER:	0
--------------------------	---	----------------	---	------------------------	---

TENGU

ESCORT CARRIER



CEGA FORCES

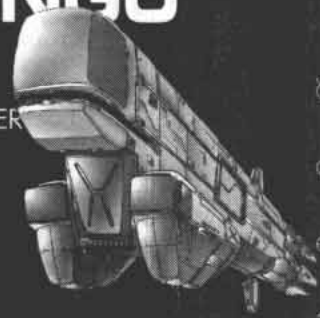

by Dream Pod 9

TV:	40	CREW LEVEL:	○○	TURN.:	Average (90°) ○○		
SIZE:	8	ACTIONS:	3 ○○	ELECTRONICS:	+1 ○○		
BASE AVOIDANCE: 2/1 ○○		DAMAGE CTRL: 3 ○○					
ROLL	COMPO.	PROTECT.	ARC	RANGE	ACC.	DAM.	NOTES
	Main Hull	12/24/36					
1	Drives	10/20/30 ○○	-	-	-	-	Thrust: 10
2	Hanger	10/20/30 ○○	-	-	-	-	Bays: 4 Cats: 2
3	Missile Bay	7/14/21 ○○	F	50	0	10E	SMis
4	Missile Bay	7/14/21 ○○	F	50	0	10E	SMis
5	POS	10/20/30 ○○	T	5	+1	2E	POS
6	No component:	-	-	-	-	-	-

NOTES:

VEHICLE CAPACITY:	8	REPAIR:	2	FLEET MANEUVER:	2
--------------------------	---	----------------	---	------------------------	---

BIRMINGHAM

ATTACK CARRIER



CEGA FORCES



by Dream Pod 9

TV:	60	CREW LEVEL:	○○	TURN.:	Sluggish (45°) ○○		
SIZE:	9	ACTIONS:	5 ○○	ELECTRONICS:	0 ○○		
BASE AVOIDANCE: 1/0 ○○		DAMAGE CTRL: 4 ○○					
ROLL	COMPO.	PROTECT.	ARC	RANGE	ACC.	DAM.	NOTES
	Main Hull	14/28/42					
1	Drives	15/30/45 ○○	-	-	-	-	Thrust: 5
2	Hanger	10/20/30 ○○	-	-	-	-	Bays: 16 Cats: 6
3	KKCs	5/10/15 ○○	T	25/50	0/-1	5P	AP, R1, St
4	Missile Bay	10/20/30 ○○	F	50	0	10E	SMis
5	POS	10/20/30 ○○	T	5	+1	3E	POS
6	No component:	-	-	-	-	-	-

NOTES:

Vehicle Capacity:	32	Repair:	3	Fleet Maneuver:	2
--------------------------	----	----------------	---	------------------------	---



POSEIDON

BATTLESHIP



CEGA FORCES



by Dream Pod 9

TV:	90	CREW LEVEL:	○○	TURN.: Sluggish (45°)	○○			
SIZE:	9	ACTIONS:	5 ○○	ELECTRONICS:	+1 ○○			
BASE AVOIDANCE: 1/-1 ○○		DAMAGE CTRL:		4 ○○				
ROLL	COMPO.	PROTECT.	ARC	RANGE	ACC.	DAM.	NOTES	
Main Hull 20/40/60								
1	Drives	16/32/48 ○○	-	-	-	-	Thrust:5	
2	Hangar	10/20/30 ○○	-	-	-	-	Bays: 10 Cats: 4	
3	P Beam	10/20/30 ○○	T	30/60	-1/2	10E	R1,H	
4	KKCs	8/16/24 ○○	T	25/50	+1/0	5P	AR, R1, R, S	
5	Missile Bays	18/36/54 ○○	F	50	0	10E	SMs, R1	
6	POS	10/20/30 ○○	T	5	+1	4E	POS	
NOTES:								
VEHICLE CAPACITY:		20		REPAIR:	4		FLEET MANEUVER:	2

HAMMERHEAD

DREADNOUGHT



CEGA FORCES



by Dream Pod 9

TV:	95	CREW LEVEL:	○○	TURN.: Average (90°)	○○			
SIZE:	8	ACTIONS:	4 ○○	ELECTRONICS:	+2 ○○			
BASE AVOIDANCE: 2/-1 ○○		DAMAGE CTRL:		3 ○○				
ROLL	COMPO.	PROTECT.	ARC	RANGE	ACC.	DAM.	NOTES	
Main Hull 18/36/54								
1	Drives	15/30/45 ○○	-	-	-	-	Thrust:10	
2	Hangar	10/20/30 ○○	-	-	-	-	Bays: 4 Cats: 4	
3	Corn Array	5/10/15 ○○	-	-	-	-	ECOM (4)	
3	Railgun	10/20/30 ○○	Spr	10/30	-1/3	11P	AD, PH1, Sw3	
4	PBeam	8/16/24 ○○	T	30/60	-1/2	8E	R1,H	
5	KKCs	5/10/15 ○○	T	25/50	0/1	5P	AR, R1, R, S	
Missile Bays		15/30/45 ○○	F	40	0	10E	SMs	
6	POS	10/20/30 ○○	T	5	+1	4E	POS	
NOTES:								
VEHICLE CAPACITY:		8		REPAIR:	3		FLEET MANEUVER:	3

NARWHAL

BOMBARD



CEGA FORCES



by Dream Pod 9

TV:	95	CREW LEVEL:	○○	TURN.: Sluggish (45°)	○○			
SIZE:	9	ACTIONS:	5 ○○	ELECTRONICS:	0 ○○			
BASE AVOIDANCE: 1/-1 ○○		DAMAGE CTRL:		3 ○○				
ROLL	COMPO.	PROTECT.	ARC	RANGE	ACC.	DAM.	NOTES	
Main Hull 20/40/60								
1	Drives	15/30/45 ○○	-	-	-	-	Thrust:5	
2	Sensors	5/10/15 ○○	-	-	-	-	ECOM(4)	
3	Railgun	10/20/30 ○○	Spr	20/60	0/2	17P	AD, Sw3, PH0, Con3	
4	KKCs	8/16/24 ○○	T	25/50	0/-1	5P	AR, R1, R, S	
5	Missile Bays	18/36/54 ○○	T	50	0	10E	SMs, R1	
6	POS	10/20/30 ○○	T	5	+1	4E	POS	
NOTES:								
Vehicle Capacity:		2		Repair:	4		Fleet Maneuver:	2

APPALACHIAN

CARGO SHIP



CEGA FORCES



by Dream Pod 9

TV:	80	CREW LEVEL:	○○	TURN.: Sluggish (45°)	○○			
SIZE:	9	ACTIONS:	3 ○○	ELECTRONICS:	0 ○○			
BASE AVOIDANCE: 0/-1 ○○		DAMAGE CTRL:		2 ○○				
ROLL	COMPO.	PROTECT.	ARC	RANGE	ACC.	DAM.	NOTES	
Main Hull 18/36/54								
1	Drives	15/30/45 ○○	-	-	-	-	Thrust: 8	
2	Cargo	10/20/30 ○○	-	-	-	-	50 cargo units	
3	Cargo	10/20/30 ○○	-	-	-	-	50 cargo units	
4	Cargo	10/20/30 ○○	-	-	-	-	50 cargo units	
5	POS	10/20/30 ○○	T	5	+1	3E	POS	
6	No component							
NOTES: Instead of cargo points, each Cargo section can be used as a Hangar with four bays and no Campaign Repair ability.								
VEHICLE CAPACITY:		2		REPAIR:	2		FLEET MANEUVER:	2

DATA CARDS

ONI

EXO-ARMOR



VENUS FORCES

by Dream Pod 9

TV:	12	ACTIONS:	1	SIZE:	3
E-TRONICS:	+1	MOVE:	10/20	FACING:	Exo
AVOIDANCE:	0/-2	PROTECT:	6/14/18, 6/14/18		
PERKS/FLAWS:	Close Combat (2), Missile Defense (2)				
ATTACKS	ARC	RANGE	ACC.	DAM.	NOTES
Twin Cannon	F	C/30	+1/0	3E	R1

ER-LANG

EXO-ARMOR



VENUS FORCES

by Dream Pod 9

TV:	17	ACTIONS:	1	SIZE:	3
E-TRONICS:	+2	MOVE:	10/20	FACING:	Exo
AVOIDANCE:	-1/-2	PROTECT:	7/17/21, 7/17/21		
PERKS/FLAWS:	Close Combat (2), ECM (4), ECCM (4)				
ATTACKS	ARC	RANGE	ACC.	DAM.	NOTES
S. Missdriever	F	35/70	-2/-1	4P	AP, Slow
Plasma Lance	F	C/5	+1	4/2E	-

RYU

EXO-ARMOR



VENUS FORCES

by Dream Pod 9

TV:	13	ACTIONS:	1	SIZE:	3
E-TRONICS:	+1	MOVE:	15/25	FACING:	Exo
AVOIDANCE:	+1/0	PROTECT:	6/12/15, 6/12/15		
PERKS/FLAWS:	Close Combat (2), Missile Defense (2)				
ATTACKS	ARC	RANGE	ACC.	DAM.	NOTES
Beam Cannon	F	C/20/40	+1/+1/0	4E	-
Missile Pods	T	20	-1	5E	Mis, ASI

BONEBREAKER

EXO-ARMOR



VENUS FORCES

by Dream Pod 9

TV:	13	ACTIONS:	1	SIZE:	3
E-TRONICS:	+1	MOVE:	10/30	FACING:	Exo
AVOIDANCE:	+1/0	PROTECT:	6/12/15, 6/12/15		
PERKS/FLAWS:	Close Combat (3), Missile Defense (2)				
ATTACKS	ARC	RANGE	ACC.	DAM.	NOTES
Shotg./Blasts	F	C/15	+1	4P	A2
Plasma Lance	F	C	+1	4E	-

KAMINARI

EXO-ARMOR



VENUS FORCES

by Dream Pod 9

TV:	17	ACTIONS:	1	SIZE:	3
E-TRONICS:	+1	MOVE:	10/20	FACING:	Exo
AVOIDANCE:	0/0	PROTECT:	7/17/21, 7/17/21		
PERKS/FLAWS:	Close Combat (2), Missile Defense (2)				
ATTACKS	ARC	RANGE	ACC.	DAM.	NOTES
Bazoo./Bayonet	F	C/30	0	5P	-
Missiles	T	C/5/20	-1/-2/-3	6E	Mis, ASI
Vulcans	F	C/10	0	2P	A2, R1

Note: may not carry add-on weapons.

GUAN GUNG

EXO-ARMOR



VENUS FORCES

by Dream Pod 9

TV:	14	ACTIONS:	1	SIZE:	3
E-TRONICS:	+1	MOVE:	10/25	FACING:	Exo
AVOIDANCE:	0/0	PROTECT:	6/12/18, 6/12/18		
PERKS/FLAWS:	Close Combat (2), Missile Defense (2), External Cargo: 1 x Exo-Suit squad				
ATTACKS	ARC	RANGE	ACC.	DAM.	NOTES
Beam Guns	F	C/30	+1/0	4E	R1, A2

SIEGFRIED

FIGHTER



VENUS FORCES

by Dream Pod 9

TV:	13	ACTIONS:	1	SIZE:	3
E-TRONICS:	+1	MOVE:	20/50	FACING:	Fighter
AVOIDANCE:	+1/0	PROTECT:	5/10/14, 5/10/14		
PERKS/FLAWS:	Missile Defense (2)				
ATTACKS	ARC	RANGE	ACC.	DAM.	NOTES
Missdriever	FF	C/20	+1	4P	R1

Note: may carry one add-on weapon (missiles only).

BRUNNHILDE

FIGHTER



VENUS FORCES

by Dream Pod 9

TV:	16	ACTIONS:	2	SIZE:	3
E-TRONICS:	+1	MOVE:	10/40	FACING:	Fighter
AVOIDANCE:	0/-1	PROTECT:	5/12/15, 5/12/15		
PERKS/FLAWS:	Missile Defense (2)				
ATTACKS	ARC	RANGE	ACC.	DAM.	NOTES
Beam Gun	FF	C/30	+1/0	5/4E	-
Tail Lasers	R	C/15	+1	2E	-

TANUKI

EXO-SUIT



VENUS FORCES

by Dream Pod 9

TV:	13	ACTIONS:	1	SIZE:	2
E-TRONICS:	+1	MOVE:	5/10	FACING:	Exo
AVOIDANCE:	+1/+1	PROTECTION:	3/5/7, 3/5/7		
PERKS/FLAWS:	Close Combat (2), Multiple Redundancy (5)				
ATTACKS	ARC	RANGE	ACC.	DAM.	NOTES
Autocannon	T	C/30	+1/0	3P	R1, A2
Grenades	T	C/5	+2	3E	Mis, A2



SAKURA

EXO-ARMOR



VENUS FORCES

TV:	37	ACTIONS:	2	SIZE:	4
E-TRONICS:	+3	MOVE:	10/20	FACING:	Exo
AVOIDANCE:	-1/-1	PROTECT:	8/16/27, 8/16/27		
PERKS/FLAWS: Close Combat(2)					
Missile Defense (3), ECCM (4)					
ATTACKS	ARC	RANGE	ACC.	DAM.	NOTES
Beam Cannon	F	C/20/40	+1/+1/0	6/5/4E	-
Missile Pods	T	C/20	0/1	6E	Miss, Sk1
Drones: I, II	-	-	-	-	Rate:2, Reload:1

Note: may not carry add-on weapons.

ALBERICH

FIGHTER



VENUS FORCES

TV:	18	ACTIONS:	2	SIZE:	3
E-TRONICS:	+2	MOVE:	10/20	FACING:	Fighter
AVOIDANCE:	-1/-2	PROTECT:	7/11/18, 7/11/18		
PERKS/FLAWS: ECM (5), ECCM (6),					
Missile Defense (3), Stealth (3)					
ATTACKS	ARC	RANGE	ACC.	DAM.	NOTES
Defense Laser	R	C/15	+1	2E	-

Note: may not carry add-on weapons.

RIENZI

FIGHTER



VENUS FORCES

TV:	13	ACTIONS:	1	SIZE:	3
E-TRONICS:	+1	MOVE:	10/35	FACING:	Fighter
AVOIDANCE:	0/-1	PROTECT:	6/11/15, 6/11/15		
PERKS/FLAWS: Missile Defense (2)					
ATTACKS	ARC	RANGE	ACC.	DAM.	NOTES
Laser Torrets	T	C/15	+1	2E	R1
SKiller Drones	-	-	-	-	Rate:4, Reload:3

KITSUNE

EXO-SUIT



VENUS FORCES

TV:	12	ACTIONS:	1	SIZE:	2
E-TRONICS:	+1	MOVE:	5/10	FACING:	Exo
AVOIDANCE:	+1/+1	PROTECTION:	1/2/3, 1/2/3		
PERKS/FLAWS: Close Combat (3),					
Multiple Redundancy (4), Stealth (1)					
ATTACKS	ARC	RANGE	ACC.	DAM.	NOTES
Assault Rifles	T	C/20	+1/0	2P	R1, A2

KORIKAZE

EXO-ARMOR



VENUS FORCES

TV:	40	ACTIONS:	2	SIZE:	3
E-TRONICS:	+3	MOVE:	15/25	FACING:	Exo
AVOIDANCE:	0/0	PROTECT:	3/8/13, 3/8/13		
PERKS/FLAWS: Close Combat (4),					
Missile Defense (3), Stealth (3), Cloak (2)					
ATTACKS	ARC	RANGE	ACC.	DAM.	NOTES
Pulse Cannon	T	C/20	+1	3P	R1, A2
Plasma Lances	T	C	+1	4E	-

DRAGON STRIKER

EXO-ARMOR



CEGA FORCES

TV:	25	ACTIONS:	1	SIZE:	4
E-TRONICS:	+2	MOVE:	10/25	FACING:	Exo
AVOIDANCE:	-1/-2	PROTECT:	8/18/24, 8/18/24		
PERKS/FLAWS: CloseCombat (2),					
Missile Defense (3), Energy Protection (9/20/27)					
ATTACKS	ARC	RANGE	ACC.	DAM.	NOTES
Beam Cannons	FF	C/25/50	+1/+1/0	7/6/5E	-
Vulcan Batteries	T	C/20	+1/0	4P	R1
Solar Missiles	F	20	-1	5E	Sk2, Miss

INFANTRY

INFANTRY



ALL FORCES

E-TRONICS:	0	SIZE:	1	FACING:	Exo
MOVEMENT:	2	SKILL THRESHOLD:	n/e		
FRONT AVOIDANCE:	+2	REAR AVOIDANCE:	+2		
PERKS: Close-Combat Optimized (1)					
Multiple Redundancy (5)					
ATTACKS	ARC	RANGE	ACC.	DAM.	NOTES
Guns, Grenades	T	C/5	0	3/1E	AP, AI (2)

SAMPLE

EXO-ARMOR



ALL FORCES

E-TRONICS:		SIZE:		FACING:	
MOVEMENT:		SKILL THRESHOLD:			
FRONT AVOIDANCE:		REAR AVOIDANCE:			
PERKS:					
ATTACKS	ARC	RANGE	ACC.	DAM.	NOTES

SAMPLE

EXO-SUIT





ALL FORCES

E-TRONICS:		SIZE:		FACING:	
MOVEMENT:		SKILL THRESHOLD:			
FRONT AVOIDANCE:		REAR AVOIDANCE:			
PERKS:					
ATTACKS	ARC	RANGE	ACC.	DAM.	NOTES

IMPERATOR

PATROL CRUISER

VENUS FORCES

TV:	45	CREW LEVEL:	○○	TURN.: Nimble (180°)	○○
SIZE:	7	ACTIONS:	3 ○○	ELECTRONICS:	+2 ○○
BASE AVOIDANCE:	2/1 ○○	DAMAGE CTRL:	2 ○○		

ROLL	COMPO.	PROTECT.	ARC	RANGE	ACC.	DAM.	NOTES
Main Hull 10/20/30							
1	Drives	10/20/30 ○○	-	-	-	-	Thrust: 10
2	Hangar	10/20/30 ○○	-	-	-	-	Bays: 2, Cats: 2
3	CMWs	8/16/24 ○○	T	C/20	+1/+2	5E	Mis. R1, S1
4	Lasers	8/16/24 ○○	F	30/60	0/-1	9/7E	Sx2
5	Missile Bay	9/18/27 ○○	T	40	0	10E	S-Mis
6	POS	9/18/27 ○○	T	5	+1	3E	POS

Notes: Venusian, Stealth 1

Vehicle Capacity:	1	Repair:	4	Fleet Maneuver:	1
--------------------------	---	----------------	---	------------------------	---

CHIEFTAIN

ESCORT CRUISER



VENUS FORCES

TV:	75/70	CREW LEVEL:	○○	TURN.: Nimble (180°)	○○
SIZE:	8	ACTIONS:	4 ○○	ELECTRONICS:	+1 ○○
BASE AVOIDANCE:	2/1 ○○	DAMAGE CTRL:	2 ○○		



ROLL	COMPO.	PROTECT.	ARC	RANGE	ACC.	DAM.	NOTES
Main Hull 13/25/39							
1	Drives	12/24/36 ○○	-	-	-	-	Thrust: 10
2	Hangar	12/24/36 ○○	-	-	-	-	Bays: 2, Cats: 2
3	KDCs	11/22/33 ○○	FF	25/50	0/-1	5P	AP R1, R2
4	Lasers	11/22/33 ○○	T	30/60	0/-1	9/7	R1, Sx2
5	CMWs	11/22/33 ○○	T	C/20	+1/+2	5E	Mis. R1, S1
6	POS	10/20/30 ○○	T	5	+1	3E	POS

NOTES: Venusian, Stealth 1

VEHICLE CAPACITY:	4	REPAIR:	4	FLEET MANEUVER:	1
--------------------------	---	----------------	---	------------------------	---

SATRAP

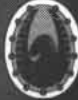
TRANSPORT CARRIER

VENUS FORCES

TV:	105	CREW LEVEL:	○○	TURN.: Sluggish (45°)	○○
SIZE:	9	ACTIONS:	4 ○○	ELECTRONICS:	+1 ○○
BASE AVOIDANCE:	1/-1 ○○	DAMAGE CTRL:	4 ○○		



ROLL	COMPO.	PROTECT.	ARC	RANGE	ACC.	DAM.	NOTES
Main Hull 17/34/51							
1	Drives	16/32/48 ○○	-	-	-	-	Thrust: 5
2	Hangar	16/32/48 ○○	-	-	-	-	Bays: 12, Cats: 6
3	CMWs	14/28/42 ○○	T	C/20	+1/+2	5E	Mis. R2, S1
3	Missile Bays	14/28/42 ○○	T	40	0	10E	S-Mis, R2
4	Cargo	10/20/30 ○○	-	-	-	-	50 Cargo Points
5	POS	10/20/30 ○○	T	5	+1	3E	POS
6	Drones: II, III	16/32/48 ○○	-	-	-	-	Rate: 2, Reload Threshold: 0

NOTES: Venusian, Stealth 1

VEHICLE CAPACITY:	24	REPAIR:	5	FLEET MANEUVER:	0
--------------------------	----	----------------	---	------------------------	---

SHAN-YU

BATTLECRUISER

VENUS FORCES

TV:	140	CREW LEVEL:	○○	TURN.: Sluggish (45°)	○○
SIZE:	9	ACTIONS:	5 ○○	ELECTRONICS:	+2 ○○
BASE AVOIDANCE:	1/-1 ○○	DAMAGE CTRL:	4 ○○		

ROLL	COMPO.	PROTECT.	ARC	RANGE	ACC.	DAM.	NOTES
Main Hull 20/40/60							
1	Drives	18/36/54 ○○	-	-	-	-	Thrust: 10
2	CMWs	14/28/42 ○○	T	C/20	+1/+2	5E	Mis. R2, S1
2	Missile Bays	14/28/42 ○○	F	40	0	10E	S-Mis, R1
3	R Beam	13/26/39 ○○	Spr	30/60	0/-1	16E	PHQ, H
4	Lasers	13/26/39 ○○	T	30/60	0/-1	10/8E	R1, Sx2
5	POS	10/20/30 ○○	T	5	+1	4E	POS
6	Hangar	18/36/54 ○○	-	-	-	-	Bays: 6, Cats: 6
6	Drones: III	18/36/54 ○○	-	-	-	-	Rate: 3, Reload Threshold: 0

NOTES: Venusian, Stealth 1

VEHICLE CAPACITY:	12	REPAIR:	7	FLEET MANEUVER:	1
--------------------------	----	----------------	---	------------------------	---



HUANG-TI

OBSERVER



VENUS FORCES



TV:	55/50	CREW LEVEL:	○○	TURN.: Nimble (180°)	○○		
SIZE:	7	ACTIONS:	3 ○○	ELECTRONICS:	+3 ○○		
BASE AVOIDANCE: 1/0 ○○		DAMAGE CTRL:		1 ○○			
ROLL	COMPO.	PROTECT.	ARC	RANGE	ACC.	DAM.	NOTES
Main Hull 8/18/27							
1	Drives	9/18/27 ○○	-	-	-	-	Thrust: 10
2	Hanger	9/18/27 ○○	-	-	-	-	Bays: 2, Cats: 2
3	Lasers	8/16/24 ○○	FF	30/60	+1/0	10/ 8E	Sw2
4	CMMs	8/16/24 ○○	T	C/20	+1/+2	5E	Mis, R1, 5e
5	PODs	8/16/24 ○○	T	5	+1	3E	POD
6	Drones: 8	8/16/24 ○○	-	Rate: 5, Reload:	○○○○○○○○○○○○○○○○○○○○		

NOTES: Venusian, Stealth 2, Cloak 1

VEHICLE CAPACITY: 4 REPAIR: 5 FLEET MANEUVER: 1

TSAR

HEAVY CRUISER



VENUS FORCES



TV:	95	CREW LEVEL:	○○	TURN.: Average (90°)	○○		
SIZE:	8	ACTIONS:	4 ○○	ELECTRONICS:	+1 ○○		
BASE AVOIDANCE: 1/0 ○○		DAMAGE CTRL:		3 ○○			
ROLL	COMPO.	PROTECT.	ARC	RANGE	ACC.	DAM.	NOTES
Main Hull 16/32/48							
1	Drives	15/30/45 ○○	-	-	-	-	Thrust: 10
2	Hanger	15/30/45 ○○	-	-	-	-	Bays: 4, Cats: 4
3	Railguns	10/20/30 ○○	Spli	10/30	0/-3	16P	AD, PHO, R2, Sw3, Con2
4	CMMs	14/28/42 ○○	T	C/20	+1/+2	5E	Mis, R1, 5e
4	Missile Bays	14/28/42 ○○	F	40	0	10E	S-Mis
5	Lasers	13/28/42 ○○	T	30/60	D/-1	9/7E	R1, Sw2
6	POD	10/20/30 ○○	T	5	+1	3E	POD

NOTES: Venusian, Stealth 1

VEHICLE CAPACITY: 8 REPAIR: 5 FLEET MANEUVER: 1

GAGARIN

TENDER



JOVIAN FORCES



TV:	80	CREW LEVEL:	○○	TURN.: Sluggish (45°)	○○		
SIZE:	10	ACTIONS:	3 ○○	ELECTRONICS:	0 ○○		
BASE AVOIDANCE: -1/-1 ○○		DAMAGE CTRL:		4 ○○			
ROLL	COMPO.	PROTECT.	ARC	RANGE	ACC.	DAM.	NOTES
Main Hull 15/30/45							
1	Drives	14/28/42 ○○	-	-	-	-	Thrust: 5
2	Ship Bay	15/30/45 ○○	-	-	-	-	Bays: 24
3	Cargo	10/20/30 ○○	-	-	-	-	150 Cargo Points
4	Missile Bay	12/24/36 ○○	F	50	0	10E	S-Mis
5	POD	10/20/30 ○○	T	5	+1	3E	POD
6	No component						

NOTES: The Ship Bay can contain any one ship Size 8 or smaller as integral cargo; in the Repair Phase, if the Ship Bay is not damaged, one ship or up to five standard units may be fully repaired at no Cargo Point cost.

VEHICLE CAPACITY: 48 REPAIR: 2 FLEET MANEUVER: 2

DETROIT

FLEET SUPPORT S



CEGA FORCES

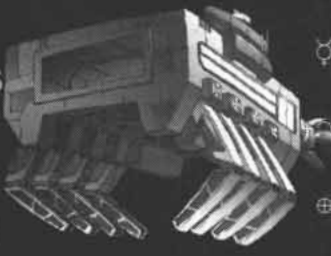

TV:	100	CREW LEVEL:	○○	TURN.: Sluggish (45°)	○○		
SIZE:	10	ACTIONS:	3 ○○	ELECTRONICS:	0 ○○		
BASE AVOIDANCE: -1/-1 ○○		DAMAGE CTRL:		4 ○○			
ROLL	COMPO.	PROTECT.	ARC	RANGE	ACC.	DAM.	NOTES
Main Hull 18/36/54							
1	Drives	15/30/45 ○○	-	-	-	-	Thrust: 5
2	Hanger	10/20/30 ○○	-	-	-	-	Bays: 18
3	Cargo	8/16/24 ○○	-	-	-	-	200 Cargo Points
4	Scaffold	6/12/18 ○○	-	-	-	-	Cond
5	POD	10/20/30 ○○	T	5	+1	3E	POD
6	Missile Bays	15/30/45 ○○	F	40	0	10E	S-Mis

NOTES: At the end of each End Phase, if the Scaffold is deployed, it automatically acts as a Toolkit (see 6.2.5) for any friendly unit in physical contact; in the Repair Phase, if the Scaffold is not damaged, one ship or up to five standard units may be fully repaired at no Cargo Point cost.

VEHICLE CAPACITY: 36 REPAIR: 2 FLEET MANEUVER: 2

INARI

MERCHANT VESSEL



ALL FORCES

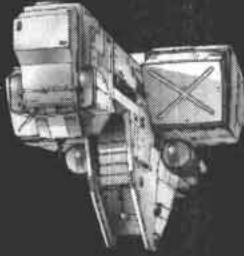

by Dream Pod 9

TV: 30 CREW LEVEL: 00 TURN: Sluggish (45°) 00
 SIZE: 8 ACTIONS: 2 00 ELECTRONICS: 0 00

BASE AVOIDANCE: 1/0 00 DAMAGE CTRL: 2 00

ROLL	COMPO.	PROTECT.	ARC	RANGE	ACC.	DAM.	NOTES
Main Hull 17/34/51							
1,2	Drives	15/30/45 00	-	-	-	-	Thrust: 5
3,4	Cargo	10/20/30 00	-	-	-	-	75 Cargo Points
5,6	POS	10/20/30 00	T	5	+1	2E	POS

NOTES:

VEHICLE CAPACITY: 2 REPAIR: 2 FLEET MANEUVER: 2

SENATOR

CORVETTE



VENESIAN FORCES

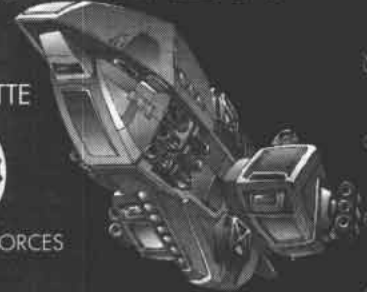

by Dream Pod 9

TV: 40 CREW LEVEL: 00 TURN: Nimble (180°) 00

SIZE: 7 ACTIONS: 3 00 ELECTRONICS: +1 00

BASE AVOIDANCE: 2/1 00 DAMAGE CTRL: 2 00

ROLL	COMPO.	PROTECT.	ARC	RANGE	ACC.	DAM.	NOTES
Main Hull 8/18/27							
1	Drives	8/16/24 00	-	-	-	-	Thrust: 10
2	Lasers	7/14/21 00	T	30/60	0/1	7/5E	Sw2, R1
3	KKCs	5/10/15 00	T	25/50	0/1	4P	AP, R1, R2, R3
4	POS	8/16/24 00	T	5	+1	2E	POS
5	No component	-	-	-	-	-	-
6	No component	-	-	-	-	-	-

NOTES: Venesian, Stealth 1

VEHICLE CAPACITY: 1 REPAIR: 3 FLEET MANEUVER: 1

EBIRU

TRANSPORT



ALL FORCES

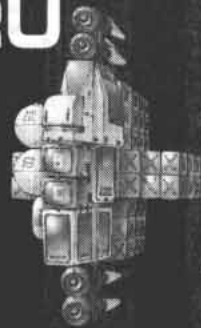

by Dream Pod 9

TV: 20 CREW LEVEL: 00 TURN: Sluggish (45°) 00

SIZE: 9 ACTIONS: 2 00 ELECTRONICS: -1 00

BASE AVOIDANCE: 0/-1 00 DAMAGE CTRL: 1 00

ROLL	COMPO.	PROTECT.	ARC	RANGE	ACC.	DAM.	NOTES
Main Hull 10/20/30							
1,2	Drives	8/12/18 00	-	-	-	-	Thrust: 5
3,4	Cargo	5/10/15 00	-	-	-	-	100 Cargo Points
5,6	POS	10/20/30 00	T	5	+1	2E	POS

NOTES:

VEHICLE CAPACITY: 2 REPAIR: 1 FLEET MANEUVER: 1

VALHALLA

SPACE STATION



ALL FORCES

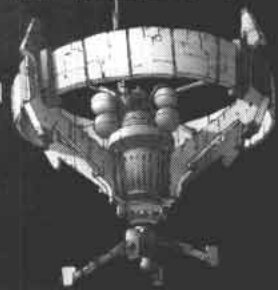

by Dream Pod 9

TV: 40 CREW LEVEL: 00 TURNING: N/A

SIZE: 10 ACTIONS: 4 00 ELECTRONICS: +3 00

BASE AVOIDANCE: -2/-2 00 DAMAGE CTRL: 4 00

ROLL	COMPO.	PROTECT.	ARC	RANGE	ACC.	DAM.	NOTES
Main Hull 20/40/60							
1	Hangar	10/20/30 00	-	-	-	-	Bay: 12
2	Com Array	5/10/15 00	-	-	-	-	ECOM (4)
3	Habitats	20/40/60 00	-	-	-	-	100 Cargo Points
4	KKCs	5/10/15 00	T	25/50	0/1	5P	AP, R1, R2, R3
5	P Beam	10/20/30 00	T	30/60	-1/2	8E	R1, H
6	POS	10/20/30 00	T	10	+1	4E	POS

Notes:

Vehicle Capacity: 24 Repair: 1/2 Fleet Maneuver: N/A



GAO-TZU

HEAVY CRUISER

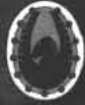

VENUS FORCES

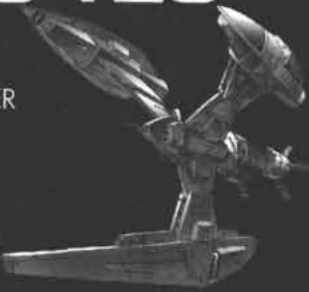

TV:	70	CREW LEVEL:	○○	TURN.: Average [90°]	○○		
SIZE:	8	ACTIONS:	4 ○○	ELECTRONICS:	+1 ○○		
BASE AVOIDANCE:	1/0 ○○	DAMAGE CTRL:	3 ○○				
ROLL	COMPO.	PROTECT.	ARC	RANGE	ACC.	DAM.	NOTES
Main Hull 16/32/48							
1	Drives	15/30/45 ○○	-	-	-	-	Thrust: 10
2	Hanger	15/30/45 ○○	-	-	-	-	Bays: 6, Cats: 6
3	Missile Bays	14/28/42 ○○	F	40	0	10E	S-Miss.R2
4	Lasers	5/10/15 ○○	T	30/60	0/-1	9/7E	R2.Sw1.Sk
5	PDS	10/20/30 ○○	T	5	+1	3E	PDS
6	No component						

NOTES: Venusian, Stealth 1

VEHICLE CAPACITY: 12 REPAIR: 3 FLEET MANEUVER: 1

SAMPLE

CLASS



NATION

TV:		CREW LEVEL:	○○	TURN.:	○○		
SIZE:		ACTIONS:	○○	ELECTRONICS:	○○		
BASE AVOIDANCE:	○○	DAMAGE CTRL:	○○				
ROLL	COMPO.	PROTECT.	ARC	RANGE	ACC.	DAM.	NOTES
Main Hull / /							
1							
2							
3							
4							
5							
6							

NOTES:

VEHICLE CAPACITY: REPAIR: FLEET MANEUVER:

A

Ablative Armor 71

Ace Cost 41

Ace Perks 40

Aces 40

Actions 20

Advanced Fire Control 71

Advanced Rules 7

Aiming 34

Anti-Infantry (AI#) 64

Anti-Missile System 71

Anti-Ship (AS#) 64

Armor Piercing (AP) 64

Armor-Destroying (AD) 64

Assault Railgun 70

Assembling the Fleet 50

Asteroids 43

Attack Roll, the 25

Attacking 24

Aura of Command 40

Avoidance 22

B

Basic Rules 7

Basic Scenario 1: The McGuffin Scenario 48

Basic Scenario 2: The Hot Flash Situation 49

Basic Scenario 3: The St. Bernard Exercise 49

Basic Scenario 4: The Alamo Eventuality 49

Basic Unit: Archer 78

Basic Unit: Barracuda 84

Basic Unit: Brunnhilde 90

Basic Unit: Decker 78

Basic Unit: Falconer 78

Basic Unit: Guan Gung 89

Basic Unit: Kaminari 89

Basic Unit: Kobalt 84

Basic Unit: Lancer 78

Basic Unit: Minotaur 84

Basic Unit: Pathfinder 78

Basic Unit: Peacekeeper 78

Basic Unit: Pylum Lancer 78

Basic Unit: Retaliator 78

Basic Unit: Ryu Bonebreaker 89

Basic Unit: Ryu 89

Basic Unit: Siegfried 90

Basic Unit: Sylene 84

Basic Unit: Tanuki 90

Basic Unit: Wight 84

Basic Unit: Wraith 84

Basic Unit: Wraith-si 84

Basic Unit: Wyvern 84

Battle Arms 71

Battle, the 52

Bays, Vehicle 72

Beam Cannon 70

Binders 9

Blind Luck 40

Boarding Actions 42

Booster Pack 71

C

Campaign Fleet Roster 59

Campaign Points 55

Campaign Scenarios 56

Campaign Stats 50

Campaign, Ending a 55

Campaign, Playing the 52

Campaign, the 7, 50

Cargo Barges 43

Cargo Points 51, 60

Cargo, Stealing 51

Carrier: Birmingham Attack Carrier 82

Carrier: Forge Patrol Carrier 76

Carrier: Intrepid Transport 76

Carrier: Tengu Escort Carrier 82

Carrier: Valiant Strike Carrier 76

Catastrophic Damage 31

CEGA Navy Fleet List 86

CEGA Navy 81

CEGA 81

Central Earth Government and Administration see CEGA

Chameleon Refit 71

Charmed Life 40

Clamping 62

Class I Drones 67

Class II Drones 67

Class III Drones 67

Claymores 71

Cloak 61

Close Combat Optimized 62

Close Combat Option, Expanded 36

Close Combat 25

Combat 21

Combining Attacks 26

Command Points 39-40

Command Unit: Fury 85

Command Unit: Hector 79

Command Unit: Pathfinder Command 79

Command Unit: Sakura 90

Command Unit: Wyvern Command 85

Common Ships 92

Concealed Sections 60

Content, Book 7

Cooperative Venusian Naval Administration see CVNA

Core Game Concepts 12

Counters 8

CVNA Fleet List 91

CVNA 87

D

Damage Control 20

Damage Procedure 28

Damage to Spaceships 29

Damage to Standard Units 29

Damage Types 28

Datacard, Spaceship 11

Datacard, Standard Unit 10

Datacards 94-110

Debris Fields 43

Decoy Pod 71

Deep Cloak 61

Defenses, Special 28

Dice Rolling 13

Dice 8, 13

Differant, What's 6

Diogenes System 71

Drone Carriers 67

Drone Class or Type 67

Drone Datacards 68

Drone Rack 70

Drones 67

Drones, Launching 68

Dust Clouds 43

E

ECCM 63

ECM 62

Electronic Counter Counter Measures see ECCM

Electronic Counter Measures see ECM

Electronic Warfare 41, 62

Elite Unit: Dragonstriker 85

Elite Unit: Konikaze 90

Elite Unit: Stormrider	79	Line Ship: Uller Missile Cruiser	82	Set-up, Initial	14
End Phase	16	Lock-on Rolls	65	Shield Mode, Defense PDS	66
Ending a Campaign	55	Low Orbit	44	Shield Mode, Offense PDS	66
Ending the Game	16	M		Shield	71
Energy/Projectile Protection	60	Main Phase	15	Ship Actions	20
Energy-Homing (EH)	64	Markers	9	Ship Equipment	71
Equipment Availability, CEGA	86	Medium Missiles	70	Ship Missile Bays	65
Equipment Availability, CVNA	91	Melee Master	40	Ship Missiles (S-Mis)	64
Equipment Availability, JAF	80	Melee Weapons	70	Ship Repair	54
Equipment, Exo-Armor and Fighter	71	Minifields	44	Ship Vector Movement	35
Equipment, Exo-Suit	71	Miniatures	8,32	Ships, Attacking with	24
Equipment, Ship	71	Missile (Mis)	64	Ships, Attacks against	24
Evading	34	Missile Defense	60	Shrouds, Noisemaker	45
EW Pod	71	Missiles, HARM	70	Single Games	48
EW Rig	71	Missiles, Heavy	70	Sixth Sense	40
Executor Copilot	71	Missiles, Light	70	Skill Bonus	13
Exo-Armor and Fighter Equipment	71	Missiles, Medium	70	Skill Level and Bonus, Aces	40
Exo-Armor and Fighter Weapons	70	Missiles, Ship	65	Skill Level	13
Exo-Armor	12,17	Modeling	32	Skill Threshold, Drone	68
Exo-Suit Equipment	71	Morale, CEGA	86	Skyhooks	43
Exo-Suit	12,18	Morale, CVNA	91	Sleeves	9
Expanded Activation Options	34	Morale, JAF	80	Slow (Slw#)	64
Expanded Close Combat Option	36	Movement and Actions, Drone	69	Snoopy Pod	71
Experience	55	Movement	17	Solar System in 2214, the	74
Explosions	31	Movement, Ship Vector	35	Space Stations	43
Exposed Fire Control	60	Moving Off the Board	19	Spaceship Datacard	11
External Cargo	60	Multiple Redundancy	60	Spaceship	12,19
F		N		Special Defenses	28
Factory Complexes	43	Navy, CEGA	81	Special Operations Ship: Huang-Ti Observer	88
Fighter	12,18	Nerves of Steel	40	Special Operations Ship: Tsar Heavy Cruiser	88
Fire Arcs	23	Neutral and International Units	92	Special Rules for Venusian CVNA Fleets	52
Fire Weapons	20	Noisemaker Shrouds	45	Special-Duty Unit: Albarich	90
First Ship Phase	14	O		Special-Duty Unit: Cerberus	85
Flak (Fl)	64	Obstacle Table, Campaign	52	Special-Duty Unit: Intruder	79
Fleet Lists	74	Obstacles	43	Special-Duty Unit: Kitsune	90
Fleet Maneuver	50, 52	Optional Rules	51	Special-Duty Unit: Mentor	79
G		Options and Add-ons	70	Special-Duty Unit: Pathfinder Sniper	79
Game Turn, the	14	P		Special-Duty Unit: Rienzi	90
Grappling	37	Parting Shot	40	Special-Duty Unit: Vindicator	79
Group Definitions, CEGA	86	Perks and Flaws	60	Special-Duty Unit: Wyvern Bomber	85
Group Definitions, CVNA	91	Perks, Ace	40	Spoof	20
Group Definitions, JAF	80	Phase, End	16	Standard Mode, Defense PDS	66
Group	13	Phase, First Ship	14	Standard Mode, Offense PDS	66
H		Phase, Initiative	14	Standard Unit Datacard	10
Hardware Reference Table	73	Phase, Main	15	Standard Unit Repair	54
Hardware	7,70	Phase, Second Ship	16	Stealing Cargo	51
HARM Missiles	70	Ping	20	Stealth	63
Haywire (H)	64	Playing Field	8	Stealthy (St)	65
HDF Ship: Gao-Tzu Defense Cruiser	88	Point Defense Systems (PDS)	65	Strategy Phase, the	52
HDF Ship: Senator Corvette	88	Power-Hungry (PH#)	64	Strategy Roll, the	52
HDF Unit: Er-lang	89	Protection, Drone	68	Support Ship: Appalachian Cargo Ship	83
HDF Unit: Ori	89	Proximity Mines	71	Support Ship: Detroit Fleet Support Ship	83
HEAT-Resistant Armor	71	Q		Support Ship: Gagarin Fleet Tender	77
Heavy Missiles	70	Quick and Wily	40	Support Ship: Lennox Cargo Ship	77
Heavy Ship: Godsfire Command Carrier	77	R		Support Ships	51
Heavy Ship: Hammerhead Dreadnought	83	Ramming	45	Survival	54
Heavy Ship: Majestic Fleet Carrier	77	Range	22	Swarmers	70
Heavy Ship: Narwhal Bombard	83	Range, Tagging	72	Sweeping (Swp#)	65
Heavy Ship: Poseidon Battleship	83	Rapid Fire (R#)	64	T	
Heavy Ship: Satrap Transport Carrier	83	Rate, Launch	67	Tagging	72
Heavy Ship: Shan-Yu Battlecruiser	88	Reaction Attacks	34	Target Designator (TD)	60, 65, 71
Heavy Ship: Ypres Battleship	77	Recovery	72	Targeted ECM	62
Hit Locations	30	Reference Sheets	111-112	Threat Value, Drone	68
I		Regrouping	54	Threshold	13
Infantry	42	Reinforced Systems	60	Thrust	20
Initial Set-up	14	Reinforcements	55	Toolkits	71
Initiative Phase	14	Reload Threshold	67	Turn Sequence	14
Inspirational	40	Repair Bots	71	U	
Installations	43	Repair Phase, the	53	Unit Types	12
Intermediate Rules	7	Repair Value	50	V	
Internal Cargo	60	Repair, Ship	54	Variable Unit Characteristics	13
J		Repair, Standard Unit	54	Vehicle Bays	72
JAF Fleet List	80	Rock Fields	43	Venus	87
Jovian Armed Forces	75	Rolls, Tagging	72	Venusian	60
Jovian Confederation	75	Ruler	8	Vernier Module	71
L		Rules, Advanced	7	W	
Launch	72	Rules, Basic	7	Weapon Characteristics, Basic	64
Launching Drones	68	Rules, Intermediate	7	Weapons, Exo-Armor and Fighter	70
Leadership	51	S		Weapons, Fire	20
Light Missiles	70	Salvage	53		
Lightning Reflexes	40	Scale	12		
Lightning Strikes	46	Scenario, Selecting a	7,52		
Line of Sight	21	Scenario: Back Shot	58		
Line Ship: Alexander Destroyer	76	Scenario: Face of the Enemy	57		
Line Ship: Athena Destroyer	76	Scenario: Full Contact	58		
Line Ship: Bricriu Corvette	82	Scenario: Headhunter	57		
Line Ship: Chieftain Escort Cruiser	88	Scenario: Knock, Knock	56		
Line Ship: Ch'in Drone Boat	82	Scenario: Nobody Home	57		
Line Ship: Constantinople MAV	82	Scenario: Outnumbered	58		
Line Ship: Corsair Frigate	76	Scenario: Vamp	56		
Line Ship: Hachiman Destroyer	82	Scenario: Vandalism	56		
Line Ship: Hydra ADB	82	Second Ship Phase	16		
Line Ship: Imperator Patrol Cruiser	88	Seek (Sk#)	64		
Line Ship: Javelin Missile Cruiser	76	Self-destruction (SD)	65		
Line Ship: Thunderbolt Cruiser	76	Sentry Pod	70		