

CONAN[®]

RUINS OF HYBORIA



QUILLIAMS
2006

CONAN[®]

RUINS OF HYBORIA

Credits

AUTHOR

Vincent N. Darlage

EDITOR

Richard Ford

ADDITIONAL TEXT

Nick Bergquist & W. Jason Peck

COVER ART

Chris Quilliams

INTERIOR ARTISTS

Eric Bergeron, Jim Brady, Slawomir Maniak, Danilo Moretti, Philip Renne & Chad Sergesketter

RPG MANAGER

Ian Belcher

PRODUCTION DIRECTOR

Alexander Fennell

PROOFREADING

Ron Bedison

PLAYTESTERS

Brian Bertrand, Mark Billanie, Tina Cook, Cindy Freeman, Craig Freeman, Brian Gellineault, Jamie Godfrey, Daryl Guignon, Richard Haines, Daniel Haslam, Brian Herrell, Mark Howe, Lucas Mackay, Danny Maloney, Alan Moore, Paul Palmer, Kevin Peterson, Robert Poulin, Ray Regular, Daniel Scothorne & Michael J. Young

SPECIAL THANKS

Thommy Wojciechowski & Fredrik Malmberg at Conan Properties.

Contents

INTRODUCTION	2
CREATING RUINS	3
CULTURES AND RUINS	26
CITY OF THE WINGED ONE	49
CITY OF THE GHOULS	55
DAGOOTH HILL	64
GREEN STONE CITIES	67
GAZAL	70
THE ISLE OF IRON STATUES	75
ISLE OF THE BLACK ONES	78
KHET	83
KUTCHEMES	86
PTEION THE DAMNED	93
TOMBS AND PYRAMIDS	99
XUCHOTL	109
EXPLORING RUINS	126
MONSTERS OF THE RUINS	137
INDEX	155
LICENSE	160

Conan: Ruins of Hyboria is © 2006 Conan Properties International LLC. CONAN®, CONAN THE BARBARIAN® and related logos, character, names and distinctive likenesses thereof are trademarks of Conan Properties International LLC unless otherwise noted. All Rights Reserved. Mongoose Publishing Ltd Authorised User. *Conan the Roleplaying Game* is released under version 1.0 of the Open Game License. Reproduction of non-Open Game Content of this work by any means without the written permission of the publisher is expressly forbidden. See page 160 for the text of this license. With the exception of the character creation rules detailing the mechanics of assigning dice roll results to abilities and the advancement of character levels, all game mechanics and statistics (including the game mechanics of all feats, skills, classes, creatures, spells and the combat chapter) are declared open content.

Printed in China.

Introduction

ANCIENT RUINS AND lost cultures are a mainstay of sword-and-sorcery fiction, especially *Conan* fiction. This book contains new rules for creating ruins, including a random generator. This generator takes the Games Master through the culture that built the ruins, the history of the ruins, how the structure came to be a ruin, its layout including defences, size and physical state, the cultural remnants of the ruin, and the alien nature of most ruins in the Hyborian Age.

After that follows a lengthy discussion on what sorts of ruins can be found in the Hyborian Age, each listed by current nationalities and cultures. Nemedian ruins are different than Turanian ruins, but how so? Also listed are sample ruins found in the various stories of the Hyborian Age, ranging from ruins mentioned by Robert E. Howard, to the multitude of ruins found in the books and comics that followed Howard's initial tales.

Some individual ruins are explored in greater detail. The City of the Winged One, from Howard's *Queen of the Black Coast*, is given an in-depth treatment, including the winged ape and the were-hyenas Conan fought.

The City of the Ghouls, mentioned in passing in Howard's *The Hour of the Dragon*, is presented for the first time with a map and a considerable amount of detail. Do you want to send chills of horror down the spines of your players? The City of the Ghouls should fill that need nicely.

The ruins of Dagoth Hill, mentioned as the place of conception for the dread Tsotha-lanti of

The Scarlet Citadel, is explored for the first time. A map and a few legends concerning the place are presented along with a detailed description.

Gazal, from a rough draft of Robert E. Howard's, is presented, as is Howard's Isle of Iron Statues. The Isle of the Black One (from *The Pool of the Black One*) is also presented.

Khet, Kuthchemes and Pteion are Stygian ruins detailed and given maps for the first time for *Conan the Roleplaying Game*. Players and Games Master's alike will relish the exploration of these historic artefacts of Stygia's past.

A particular favourite of many *Conan* fans is the green city of Xuchotl, described by Howard in *Red Nails*. Detailed maps of each of these tiers are presented for Games Masters. Be careful – it is easy to get lost in Xuchotl without a map to show the way.

Further, maps presenting generic Green Stone Ruins for the Games Master's own use are also provided.

All of this is followed by a section on exploring ruins, which includes rules for cave-ins and traps, as well as a trio of new feats for ruin explorers.

The final section is a bestiary of monsters commonly found in Hyborian Age ruins and a section on making monsters more unique. This bestiary includes serpent-men (which feature in de Camp's *Conan* stories and Howard's *Kull* stories) and the child of Set (from *The God in the Bowl*).



Creating Ruins

A RANDOM RUIN GENERATOR

SOMETIMES AN IDEA for a ruin forms in a Games Master's mind and there is no difficulty translating that to the game. Other times, the Games Master may know he wants a ruin but cannot decide on his specific needs and it seems like all the ideas are ripped straight from the pages of Robert E. Howard without hardly any modification. The following generator is intended to spark the imagination so it can be used for random elements or pick and choose the elements that seem most relevant. Use the generator in any order desired; there is no particular reason to use it in the order it is presented. Sometimes beginning with the history may suggest things about the structure of the ruin. On the other hand, knowing the layout and some things about the structure may suggest its history.

CULTURAL NATURE OF THE BUILDERS

Sometimes knowing something about the culture of the race that built the ruins can help spur the direction of its history or its structure. A warrior culture will have more castles and battlements in its ruins while a primarily agrarian culture will have more canals and irrigation ditches. Roll a d20 (or simply choose) for a cultural type from the table below. There is no reason to limit yourself to just one roll if you want a more complex society. A noble/warrior culture might be feudal in nature, while an agricultural/religious centre will possibly worship nature gods.

Cultural Type

d20	Basic Cultural Type
01-02	Agricultural
03	Artistic
04	Capital
05-06	Decadent
07	Industrial
08	Noble
09	Pirate
10-13	Religious
14-15	Scholarly
16	Thief
17-18	Trader
19-20	Warrior

Agricultural: The culture has developed a strong agriculture and can deal with harsh seasons most of the time. The ruin is unlikely to be large if it had a mostly pastoral/agrarian culture. This also includes fishing settlements.

Artistic: An artistic culture is a city primarily devoted to the arts; the ruin may once have been an artistic commune or a settlement of craftsmen serving a larger city.

Capital: The city is the seat of government for a larger area. A capital may have another cultural type attached to it.

Decadent: The culture could coax sustenance from the air and was so used to luxury it grew stagnant. The people were given to great extremes of hedonism and had few morals or standards.

Industrial: The settlement had achieved a marked advancement in technology (although still low by modern standards), perhaps utilising water power to grist mills or saws. Logging villages or mining towns may be of this sort.

Noble: A noble culture exists to serve the wealthy. Art and diplomacy are the name of the game in these cultures. The lower classes are oppressed and/or ignored.

Pirate: A pirate culture is often governed by some sort of charter or set of articles that the various crews agree to uphold.

Religious: The city existed for religious reasons; it was a religious centre for an entire culture devoted to a god or set of gods. This is often a temple building society dedicated to using a vast amount of its resources to honour the gods. Often the culture was dominated by a strong theocracy. Stygia is an example of this sort of society.

Scholarly: Much like the Stygian city of Kheshatta, this culture was driven by scholarly pursuits, science and intellectual acumen. Libraries, laboratories and academies probably dominate the ruin.

Thief: A thief culture would resemble the City of Thieves in Zamora. The culture was dominated by gangs and crime families.



Trader: A trader culture is geared toward getting goods from one place to another. The city may use land routes, river routes or may be (or once have been) on the shore of a lake or ocean. The ruin was once an important market.

Warrior: A warrior culture treats war as its main activity. The whole culture leans toward war and its rulers are veteran combatants. This culture is not necessarily violent on an individual level – it may view war as an art and philosophy, or the settlement may just have a defensive function for a larger culture, such as Sukhmet in Stygia. The culture may be crude and brutal in its methods or it may be sophisticated, using forms of martial arts.

ETHNIC TYPE

If desired, a Games Master can roll or choose a racial or ethnic type for the ruins and their builders. Keep in mind that having a racial type does not necessarily indicate location. Robert E. Howard's stories were replete with Shemite or Kothic cities founded in the Black Kingdoms, Aquilonian cities on Cimmerian soil or Aquilonian cities in the Pictish Wilderness; and other pastiches have included Corinthian cities founded in Zamora and Nemedian cities founded in the Border Kingdom. If not already known, a second roll can be made to randomly determine the ruin's location.

Ethnic Type

d100	Ethnicity
01-02	Aboriginal
03-04	Acheronian
05-06	Aquilonian
07-08	Argossean
09	Ashur (see page 40)
10	Barachan
11	Border Kingdom
12-13	Brythunian
14	Cimmerian
15-17	Corinthian
18-19	Darfari
20	Ghulistani
21-22	Giant-King
23-29	Green-stone Builder
30-31	Hyperborean
32-33	Hyrkanian
34-35	Iranistani
36-37	Keshani
38-39	Khari
40	Khaurani
41-43	Khitani
44	Khorajan
45-47	Kothic
48	Kushite
49	Mutare (see page 41)
50-54	Nemedian
55-56	Nordheimer
57-58	Ophirean
59-65	Other
66	Pictish
67-73	Pre-human
74	Puntish
75-77	Shemite
78	Southern Black Kingdom
79-82	Stygian
83-84	Turanian
85-90	Unknown
91-92	Vendhyan
93-94	Zamorian
95-96	Zembabwan
97-98	Zhemri
99-100	Zingaran

HISTORICAL NATURE OF THE RUIN

History is important for getting a feel for a ruin. How old is the ruin? Is the ruin a village abandoned 10 years ago for mysterious reasons or is it an ancient citadel thousands of years old? Howard's ruins almost always included historical elements with characters often discovering the history through interaction with the inhabitants or through dreams and visions. History makes the ruin seem more real and concrete in the minds of the Players, instead of just being a random dot on the map.

The tables below can be used to generate (or inspire) a skeletal history for your ruin. Roll as many times as needed or desired on the tables to piece together a general framework. Specifics, however, will need to be provided from your imagination.

THE BEGINNINGS OF THE CIVILISATION

This part of the history is optional. It is okay to leave the beginnings of the civilisation vague or lost to time. The beginning of the Acheronians and the Giant-Kings fall into this category.

This list is by no means exhaustive but is intended to spark the imagination. Many of the details will need to be filled in by the Games Master; these tables provide the merest skeleton of the culture's beginning.

In The Beginning

d20	Source of Culture
1-2	Atlantean or pre-Cataclysmic Thurian Culture
3-4	Cataclysm
5-6	Colony
7-8	Death of Prior Culture
9-10	Good Location
11-12	Migration
13-14	Omen
15-16	Outpost
17-20	Unknown

Atlantean or pre-Cataclysmic Thurian Culture:

The culture sprang from something pre-Cataclysmic, such as the Zhemri or the Picts.



Cataclysm: The culture's beginnings are rooted in either the Great Cataclysm or the lesser cataclysm.

Colony: The ruin had its beginnings as a colony for a larger civilisation.

Death of Prior Culture: Another culture had a cataclysmic end and the builders of the current structure simply built on top of their ruins – or just occupied their space.

Good Location: The site was chosen because of defensibility or access to natural resources.

Migration: Like the culture that built Xuchotl, the people migrated from elsewhere to the ruin.

Omen: The culture decides to build a civilisation because of an omen. The Aztecs are reputed to have built their civilisation after an eagle was seen perching on a cactus, a sign they were told to look for.

Outpost: The ruin had its beginnings as an outpost for a larger civilisation.

Unknown: The beginnings of the civilisation are lost to prehistory; the shroud of time is too thick to pierce.

ANCIENT EVENTS & PERIODS

Possibly some events from the ancient history of the civilisation are known. Generally only the greatest of events will be recorded for posterity that date back to the earliest era of a culture. Cultures may have a classic era (golden age), a post-classic era and/or a pre-classic era.

Post-Classic Era: Changes cause the end of the classic age of the culture. Growth may continue or may falter. Some cultures have more than one post-classic era, such as an early, middle and late post-classic era, each with its own events.

Pre-Classic Era: Societal forms are developing. Some cultures have more than one pre-classic era, such as an early, middle and late pre-classic era, each with its own events.

Ancient Events & Periods

d20	Event or Period
01	Builder Era
02	Discovery
03	Enslavement
04	Epic War
05	Expansion of Nobility
06	Expansionary Period
07	Founding
08	Golden Age
09	Grand Edifice Constructed
10	Great Cataclysm or Lesser Cataclysm
11	Legendary Figure
12-13	Lesser Cataclysmic Change
14-15	Natural Disaster
16	Period of Peace
17	Period of War
18	Plague
19	Religion
20	Renaissance Period

Builder Era: Society begins carving large monuments (giant heads, statues, monoliths, sphinxes, and so on).

Discovery: Development of Calendar, Alphabet or Writing System. Bronze or Iron discovered. Canals or irrigation methods discovered.

Enslavement: The culture is conquered or enslaved by another people but later returned after their freedom is won. Alternatively, another culture defeats them and lives in the site, either replacing the old culture or mingling the two cultures into one.

Epic War: Culture wages an intense war against a rival culture or holds off an invasion and often a Legendary Figure is involved. If desired, roll on the War table and/or Agents of Change table (page 11 and 12, respectively).

Expansion of Nobility: The noble classes become independent from the crown and the culture disintegrates into rival factions. After a period of war a Legendary Figure reunites the culture, or a conquering nation takes its place on the site. This can alternatively be the expansion of any class of people in the city. Perhaps the soldier class has expanded and gained new power, or the priestly class, or the merchant class, or the craftsman class or the scholarly class.

Expansionary Period: Creation of networks of trade, new towns created, new towns conquered, new lands or peoples conquered, the culture's wealth attracts new settlers, creation of colonies.

Founding: The ruin is founded, the capital city is founded or some other well known relic or location related to the site and/or culture is founded. This can also include the founding of a dynasty.

Golden Age: The culture enters a period of prosperity and well-being for its citizens. During this time most of the populace (with the possible exclusion of slaves) will have plenty to eat, more than adequate shelter.

Grand Edifice Constructed: A massive pyramid (or collection of pyramids), temple, monument or palace is built, a construction project worthy of infamy or legend.

Great Cataclysm: The Great Cataclysm rocks the culture, bringing major changes. Roll again on this table to find the following event, if any. This may be the end-time event that destroys the culture. If the culture was founded after the Great Cataclysm, ignore this roll and roll again.

Legendary Figure: A legendary figure plays an important role in some aspect of the culture. The person may be a ruler, or even an artist or architect (such as Imhotep in ancient Egyptian history). King Kull would be a legendary figure,

as is Thugra Khotan (see *Black Colossus*). The legendary figure may be related to the culture as a whole or specific to the ruin. King Epeus the Sword-wielder (of Aquilonia) and King Bragorus of Nemedra are also legendary figures. The entries in the Cultures & Ruins chapter include some known historical figures for tying into a particular ruin if desired.

Lesser Cataclysm: The lesser cataclysm rocks the culture, bringing changes in the culture, if not ending it. Roll again on this table to find the following event, if any. This may be the end-time event that destroys the culture. If the culture was founded after the lesser cataclysm, ignore this roll and roll again.

Lesser Cataclysmic Change: Roll on the Cataclysmic Change table (page 8). The event does not destroy the culture, however, but it may bring about changes, affecting behaviour or beliefs.

Natural Disaster: A natural disaster rocks the culture or settlement. It does not destroy the culture but it does bring about changes. Roll on the Natural Disaster table (page 9) or choose a desired disaster.

Period of Peace: A general period of peace and prosperity has befallen the culture.

Period of War: Some important city or ruler fell, creating a period of unremitting war as the culture attempts to fill the vacuum of power. If desired, roll on the War table and/or Agents of Change table (page 11 and 12, respectively).

Plague: Messantia's middle period is characterised by a reign-long plague that still affects the people (see *Conan: Messantia – City of Riches*).

Religion: A religion develops or is further refined. The power of the cult (or cults) overshadows the power of the crown, or the reverse happens, and the throne oppresses the religion. A demon-god may be summoned to live among the people at this point in history, and given a home in the temple.

Renaissance Period: The culture has entered a period of cultural revolution as they explore new ways of doing old things and go about the process of reinventing themselves. Arts and humanities have the centre stage during this period – and the culture may be at odds with its traditional religion and/or rulers. The culture may have become hedonistic or even more puritan in its style.

END TIMES

How a civilisation or city ends is important to give the ruin historical atmosphere or to provide food for weird dreams

of the past. The list below, by no means exhaustive, contains ideas on how a civilisation may falter and die. Feel free to mix and match, combining multiple elements. In *Red Nails*, the city of Xuchotl died when a slave opened the doors of the city and let in an invading force after the city already lost the ability to defend itself. The invading force then fell to warring among divisive factions until all were slain. Ultimately, the first step toward the fall is usually due to the city somehow losing the ability to defend itself from the coming cataclysmic event due to drugs, Corruption, religious beliefs, trust, stupidity or general decadence.

These lists are by no means exhaustive but are intended to spark the imagination. Many of the details will need to be filled in by the Games Master; these tables provide the merest skeleton of the culture's end-time history.

Cataclysmic Change

d20	Change Event
01	Curse or sorcery
02	Fire
03	Invasion
04	Mass corruption
05	Mass infertility
06	Mass riots
07	Mass sacrifice
08	Mass suicide
09	Monster attack
10	Natural disaster
11	Notorious leader dies
12	Plague
13	Raids
14	Scandal
15	Secrets-man-was-not-meant-to-know
16	Technological change
17	Trade disaster
18	Vanishing population
19	War
20	Widespread religious change

Curse or Sorcery: A curse was laid upon the city by a demon or sorcerer which ended the civilisation. The people may have been changed into plants, animals or monsters (by degrees or overnight), or they may have fallen into degenerated forms of worship, summoning up a demon god who then devoured them. The city could have been laid to waste by a sorcerer and his minions. Roll or choose who the source of the curse was on the Agent of Cataclysmic Change table on page 12.

Fire: Fire is a common cause for disasters, especially in a ruin comprised more of wood than stone. It can be man-made or natural. Fire can be

within the city walls or it could devour all the crops on a city's perimeter. Forest fires and other wildfires can rampage out of control, destroying both crops and settlement. Roll or choose the incendiary agent on the Agent of Cataclysmic Change table on page 12, discarding any rolls that do not make sense.

Invasion: Acheron fell because of invading Hyborians, the Giant-Kings fell because of an invading force of proto-Stygians and the founders of Xuchotl fell when the Tlazitlans invaded. The invasion can be a peaceful, long-term infiltration of society that ultimately changes the inhabitants or it can be brutal, an all-out war that decimates the society. Roll or choose who the invader was on the Agent of Cataclysmic Change table on page 12.

Mass Corruption: *The Queen of the Black Coast* describes how a beautiful civilisation came to be altered through the corruption of a river. Some source, perhaps green, glowing stones, perhaps a meteorite, causes the people to grow Corrupt, ending the civilisation over time. Roll or choose who brought the Corruption to the settlement on the Agent of Cataclysmic Change table on page 12.

Mass infertility: Either sex becomes infertile, dooming the civilisation. Alternatively, an entire sex was killed, making reproduction impossible. This could be an act of madness, war or vengeance. If an entire sex is destroyed the civilisation cannot grow further. They may just die out if isolated, or be forced to attack/raid other settlements for members of the opposite sex, resulting in a devastating war. Roll or choose from on the Agent of Cataclysmic Change table on page 12 to determine who or what killed the people, ignoring any rolls that do not make sense.

Mass riots: For whatever reason, the city is torn apart by riots. Roll or choose who or what started the riots on the Agent of Cataclysmic Change table on page 12.

Mass sacrifice: The religion of the region begins slaughtering its own people in an attempt to appease the gods. Unfortunately, the priests in their fervour went to far and sacrificed so many people the settlement or civilisation was unable maintain its society. It may have been conquered or it may have just died out. If desired, roll on the Agent of Cataclysmic Change table on page 12 to determine what exactly the priests were trying to change or end.

Mass suicide: The culture decides (or is forced to decide) to destroy itself. If desired, roll on the Agent of Cataclysmic Change table on page 12 to determine who or what talked them into it, discarding any rolls that do not make sense.

Monster attack: A monster or demon attacked the city or civilisation and destroyed it. The monster or demon may still be present, living nearby or long since gone on.

Natural Disaster: Natural disasters can be of many types. Roll (or choose) on the Natural Disaster table on page 9. If desired, roll or choose who caused the disaster (or whose lack of preparedness allowed the civilisation to die or leave the site) on the Agent of Cataclysmic Change table on page 12.

Notorious leader dies: This could be from natural causes, sorcery or assassination. The civilisation, not wanting to remember the leader, vacates his capital city, never to return. Roll or choose on the Agent of Cataclysmic Change table on page 12 to determine who killed the leader or what he did to deserve to die and be forgotten, ignoring any rolls that do not make sense.

Plague: Plague, brought about by sorcery, demons, filth, vermin or any other source, can devastate a city or even a whole civilisation. Maybe newcomers, wanting only to trade, brought a virus the civilisation did not have an immunity against. Maybe the virus still lurks, dormant, waiting to be disturbed.

Raids: Frequent skirmishes on the borders or along the trade routes have, over time, weakened the defences and population of the settlement or civilisation. Although the raiders never really conquer the population, the nation relocates or dies anyway.

Secrets-man-was-not-meant-to-know: A scholar delved too deep in the black wells of knowledge and brought back some horrible creature that destroyed the civilisation. Often the destruction is Lovecraftian in style and involves some Cthulhoid beast.

Technological change: Technology the civilisation is not ready for is developed, or a foe creates some advanced weapon or metal that makes this civilisation's arms obsolete.

Trade disaster: Trade routes change, resources dwindle or diplomacy fails, causing the city to dry up economically. People abandon the city for opportunities elsewhere.

Vanishing Population: Like the American colony on Roanoke Island, the people of the settlement simply vanished and left no trace of where they went or why they left. At best, a cryptic note may be the only clue to the people's whereabouts and/or final fate.

War: Much like the factions in *Red Nails*, a city could find itself divided into multiple sections constantly fighting and eventually everyone is killed. Roll for or choose a type of war on the War table, then roll or choose a cause of the war on the Agent of Cataclysmic Change table.

Widespread religious change: The establishment of a new religion or the overthrow of an old religion.

Natural Disaster

d20	Disaster
01	Avalanche or Landslide
02	Cold or Heat
03	Drought
04	Earthquake/Igneous Eruption
05	Fire
06	Flood
07	Hurricane
08	Impact Event
09	Infestation
10	Lahar
11	Land Poisoned
12	Lightning
13	Limnic Eruption
14	Mud Volcano
15	Storm Surge
16	Tornado
17	Tsunami
18	Volcanic Eruption
19	Winter Storms
20	Widespread Climate Change

Avalanche: An avalanche is a crushing slide of snow, rock and debris down a slope, burying and crushing everything in its path. There are two kinds of avalanches: slab and powder. The ruins left behind by an avalanche may be buried or partially buried, crushed and broken.

Cold: Unexpected and extreme cold snaps in areas not accustomed to such variations can kill crops, animals and people.

Drought: A drought is a dry condition without rainfall. Water sources dry up and food withers away. If the condition persists long enough, dust storms or other desert-like phenomena can occur. This can also be caused by poor soil or poor agricultural techniques. This roll could also include a river changing course, which is not necessarily a drought, but can force a settlement to abandon the river, leaving behind a ruin. Drought can cause famine, war, economic damage, social unrest, migration, relocation and disease.

Earthquake: An earthquake is characterised by the land shaking, cracking and moving. It can topple buildings. In cultures where a demon-god is trapped and worshipped in the temple, such an earthquake could unleash a monster that devours the countryside. When all are dead, the demon either moves on or returns to its ruined temple to await explorers and thieves. The ruins left behind by a massive earthquake are usually in a crumbled and broken state.

Fire: Wildfires can devastate a community, although they are often naturally occurring forces and part of a natural ecosystem. The burning of a forest often removes the vegetation that prevents erosion, so a storm after a fire can cause ash flows, mudslides and flash floods, all of which can take out a settlement that might have otherwise survived the fire. Wildfires often have up to three components: crawling fires, crowning fires and jumping fires. The crawling fires are wildfires along the ground. Crowning fires are fires high up in the trees; these fires suck the oxygen from beneath them and may cause asphyxiation to those on the ground. Jumping fires are fires that spread from wind-borne leaves and branches starting fires elsewhere, even over rivers, roads or firebreaks. Fires can also be started by lightning.



Flood: Floods can happen for a variety of reasons. The soil may be unable to absorb all the water from a rainfall creating a flash flood, a dam or dike could fail, a hurricane could occur, and flooding can come from storm surges, tsunamis, earthquakes or other causes. Glacier ice melted by volcanic activity can cause flooding, mudslides or lahars.

Heat: Unusual heat waves can cause hypothermia or heat-related deaths, as well as droughts and wildfires. The destruction of crops and/or massive deaths from heat can cause migrations or war. Heat waves can also cause derechos, fast-moving thunderstorms that remain on a stationary front. Heat waves can melt glaciers or ice-caps, causing flooding or lahars.

Hurricane: Hurricanes, tropical cyclones and typhoons are insanely powerful storms, generating high winds, heavy rains, tornadoes and storm surges. The storm surge created by a hurricane is what kills 80% of a hurricane's victims. Disease and transportation difficulties are often left in the wake of a hurricane.

Igneous Eruption: Like the explosion that covered historical Pompeii, a volcanic explosion can leave intact but buried ruins or can crush everything in its path.

A volcanic eruption happens when materials are ejected through the surface of the earth.

The ejected material might be magma, water mixed with minerals (mud), small bits of rock and/or gases.

Mud volcanoes are discussed in a separate entry; this entry concerns igneous ejections. Magma can be highly fluid or highly viscous. The more viscous the magma, the taller the volcano will be or will become. Lahars and pyroclastic flows are common when a volcano erupts. The melting of glaciers and mountain snow often creates devastating lahars. Pyroclastic flows are superheated flows of poisonous gases and ash that cannot be outrun. It was a pyroclastic flow that destroyed and buried Pompeii.

Impact Event: An impact event refers to the collision of an extraterrestrial object with the Earth. The ruin could have been hit by a meteor (which would leave little in the way of ruins) or simply have been close enough to have been wiped out by the resulting blast from the impact. The ruins may include an impact crater or its remains may be near an impact crater, although erosion or other natural processes (such as filling up with water to form a lake) can disguise or hide craters. If the impact was large enough, the city may be so far from the impact site to make the determination of the fate of the city difficult. Impact events on the ocean may cause tsunamis which may wipe out cities and/or civilisations. Tektites (small bits of fused glass) or shock quartz are often found in the area, formed when the impacting object hit.

Infestation: Termites, lice, rats, frogs, locusts or other infestations could have destroyed the city or forced the people to resettle elsewhere.

Lahar: A lahar is a mudslide made of water and pyroclastic materials belched forth from a volcano. Lahars are fairly fast and can move for miles, burying villages and cities beneath

tens or hundreds of feet of mud. The consistency of a lahar is similar to mortar or concrete – liquid when moving but solidifying quickly when it stops.

Land poisoned: Land can be poisoned by Corruption, salt or alchemical means, causing defective crops or not allowing crops to be grown. The land must be abandoned or the people must change their lifestyles dramatically. The unnamed city of the Winged One in the *Queen of the Black Coast* is an example of a city destroyed by a river becoming Corrupt.

Landslide: Landslides and mudslides are similar to avalanches, except they involve earth or mud instead of snow. Heavy rains, volcanic activity or earthquakes are typical causes of landslides. They are also caused by erosion, particularly when rivers, glaciers or other water activity undercuts the soil above. Like lahars and avalanches, mudslides can happen quickly and bury an entire settlement beneath tons of earth.

Lightning: Lightning is an electrical discharge common during various types of storms. Lightning can strike people or objects, killing them or setting them on fire.

Limnic Eruption: A limnic eruption occurs in lakes saturated in carbon dioxide. These lakes are usually near volcanoes, although the bottom of the lake is not volcanic per se. The bottom of the lake has a cooler thermal layer than the top and most of the carbon dioxide is at the bottom. Eventually the carbon dioxide at the bottom of these lakes becomes unstable due to the intense saturation. At this point, all the unstable lake needs to erupt is a trigger – often an earthquake, landslide, volcanic activity or even an explosion of a sorcerous or alchemical nature. Once triggered, the lake ‘overturns’ and the carbon dioxide explodes out of the lake in an immense cloud. This cloud of carbon dioxide is heavier than air and shoves breathable air upwards as the cloud expands over the lake basin, sometimes covering an area extending twenty miles out. Any creature living around the lake will die of asphyxiation. Some lakes have recurring limnic eruptions occurring every hundred or thousand years or so, others are more irregular. The limnic eruption is often accompanied by a small tsunami caused by the eruption of gas. Unless the structure was in the path of the tsunami, the ruins left behind by a limnic eruption are usually intact, as the gas does not harm it.

Mud Volcano: A mud volcano is a geologic process spewing methane and/or carbon dioxide and other gases along with a slurry of fine solids mixed with water. Although most mud volcano eruptions are small, some can bury a site beneath a hot mineral slurry.

Storm Surge: A storm surge is a wind-driven, rush of water onto the shore; it is usually the most fatal part of a hurricane. It slams onto the shore with immense power, destroying

everything in its path not able to withstand its battering-ram-like impact, able to even scour a beach down to bedrock.

Tornado: Tornadoes are violent storms that spin in circles, forming a shape like a cone with its point on the ground and the wide, circular end up in the sky. Houses and buildings hit by a tornado often look as though have exploded from within. Tornadoes can lift horses, wagons and war machines and hurl them about. Tornadoes over the water are called waterspouts.

Tsunami: A tsunami is a massive wave displacement that, while unnoticeable on the high seas, can devastate harbours and coastlines, scouring shores down to the bedrock, crushing buildings and moving moored ships inland. Tsunamis are usually caused by volcanic activity underwater, plate tectonics, earthquakes, landslides and impact events.

Winter storm: Blizzards, winter storms with high winds and blinding snow, can damage buildings and kill people. Extremely severe blizzards are so blinding that the ground and the sky look identical, causing people to become disoriented and lost. Powerful snowstorms can pile enough snow on a house to collapse its roof.

Widespread climate change: Ice ages, cataclysms, global warming and other world-wide changes can end a civilisation. This can be brought about by axis shifts, impact events or the passing of a comet. This can also include more localised changes – the drying up of a sea, the deforestation of a jungle land, erosion, the movement of a river off its ancient course and other changes that might destroy a settlement or civilisation. The great cataclysm or the lesser cataclysm (see page 7) is often cited as the end of many civilisations, the ruins of which can still be found during the Hyborian Age.

War

d20

Type of War

1-2	Conquest by Foreigners
3-4	Conquest of Foreigners
5-6	Crusade (external)
7-8	Crusade (internal)
9-10	Economic War
11-12	Epic War
13-14	Feud
15-16	Racial War
17-18	Rebellion
19-20	Succession

Conquest by Foreigners: Foreigners invaded the land and defeated the settlement or civilisation. The victors may have killed all the victims or enslaved them, driving them away from their cities. This could have

been a formal war or a guerrilla war. Roll or choose from on the Agent of Cataclysmic Change table below to determine the cause of the war.

Conquest of Foreigners: The kingdom went to war with someone else and overextended its resources, allowing its own infrastructure to unfold. Perhaps the war went well and the kingdom or settlement conquered the other people, then moved into that land, leaving their old land as a ruin. Roll or choose from on the Agent of Cataclysmic Change table below to determine the cause of the war.

Crusade (external): A religious war against an external race or religion has exhausted the resources of the civilisation or settlement, allowing it to fall – or a religious war from another foreign force defeated them, enslaving them and moving them away or killing them all. Sometimes a religious war is not about conquering an enemy or acquiring new lands, but is engaged solely for obtaining as many prisoners as possible for sacrifice to a god or demon.

Crusade (internal): A religious war within the civilisation itself (what might happen in Aquilonia if the religions of Mitra and Asura ever take up arms against each other) destroys it in a religiously-motivated civil war.

Economic War: Instead of using force of arms, another culture wipes out the one in question by destroying its economy. Perhaps the foreign force lays siege to all the trade routes, burns down all the fields, poisons the water or performs more economic means to dry up trade, forcing the people to abandon the site. Roll or choose on the Agent of Cataclysmic Change table below to determine the cause of the war.

Epic War: An epic war is a war that to this day, is spoken of in great tales in the halls of the world. The civilisation fell to the invading Hyborians, or in some other great war of renown. Characters can make Knowledge (history) (DC 5), Knowledge (local) (DC 8) or an Intelligence (DC 18) check to know something of the war. King Kull's war against the serpent-men is an example of an epic war.

Feud: A feud is an argument between families or factions that has escalated into a full-scale war. The war in Xuchotl during *Red Nails* is an example of a feud. Often the initial impetus for the feud becomes forgotten with time, but the hostilities continue. Roll or choose from on the Agent of Cataclysmic Change table to determine the cause of the feud.

Racial War: Race has been the subject of war more than once in history. The Hyborian war against the Acheronians could be considered a form of race war.

Rebellion: A rebellion is a war against the established government. Civil wars, slave revolts, insurrections, insurgencies and even non-violent protests and calls for revolution are all forms of rebellion. A revolution is a complete upheaval of the social order, while most rebellions are against one particular cause. Roll or choose on the Agent of Cataclysmic Change table below to determine the cause of the rebellion, which may even suggest the form of the rebellion.

Succession: Successors to the throne are not always clear, desired or strong. Wars of succession are similar to rebellions but centre on two or more contenders to some position of power. This could be the throne of the kingdom, or to a powerful position such as court scholar or legal heir to an otherwise uncontested throne.

Agent of Cataclysmic Change

d20	Cause of End Times
01	Barbarians
02	Beautiful Woman (Temptress)
03	Celestial event
04	Cult
05	Demon
06	Foreign Agent
07	Government
08	Mass Corruption or General Decadence
09	Migrant Culture
10	Mistake
11	Multiple agents (roll twice more)
12	Nature
13	Nobles
14	Oppressed population (slaves, etc.) or person
15	Religion
16	Rival civilisation
17	Ruler of civilisation
18	Scandal
19	Sorcerer
20	Uncontrolled Cultural Trait

Barbarians: A barbarian or nomad race has invaded. Historically, the Mongol horde serves as an excellent example of this type of agent. The Hyborian invasion of Acheron is a Hyborian Age example of a barbaric invasion. The Pictish invasion of the Westermarck is another.

Beautiful Woman (Temptress): A beautiful woman sparked the end, much like how Helen brought about the Trojan War, or how Tascela caused the feud that destroyed the Xuchotlan Tlazitlans in Howard's *Red Nails*. A second and third agent may be rolled or chosen if desired.

Celestial event: A meteor has struck the earth, causing earthquakes or fires, or was taken as an omen which caused

panic and war. Eclipses may portend success, so the culture engages in a war that dooms it. Essentially a celestial event occurs and either directly causes the end or causes the people to act in such a way that they effectively extinguish their own culture.

Cult: A cult has caused the end of the civilisation. They may have ignited the fires, brought upon the curse of a demon, invited in the barbarians, brought about decadence and weakness, taught a philosophy of non-violence that allowed a foreign kingdom to invade and enslave the culture or any number of activities related to the end. Perhaps the cult cut down or destroyed the natural barriers protecting the city from nature's wrath, allowing a hurricane to drown the city. If desired, a trait may be rolled or chosen on the Agent Traits table on page 14.

Demon: A demon from the outer dark brought about the cataclysm, either directly or indirectly.

Foreign Agent: A foreigner brought about the cataclysm, intentionally or accidentally. This can be a single person or simply a foreign government or leader. If desired, a trait may be rolled or chosen on the Agent Traits table. A second agent may also be rolled.

Government: The government bureaucracy could impede the salvation of the civilisation. Government could simply be rotten to the core, causing oppression or other end-times scenarios for the settlement or culture. If desired, a trait may be rolled or chosen on the Agent Traits table which may suggest how the government brought about the end.

Mass Corruption or General Decadence: *The Queen of the Black Coast* describes how a beautiful civilisation came to be corrupted. The city of Xuthal in Howard's *Xuthal of the Dusk* is ending because of general decadence. This can include mass inbreeding which ultimately brings down the civilisation. The government can become so corrupt that it actually ceases to function, allowing the end to happen almost without resistance.

Migrant Culture: A culture on the move decided to settle where the ruin is now located. The fall of the Giant Kings to the Khari (Stygians) is an example of this in the Hybrian Age.

Mistake: A horrid mistake was made which brought about the end. If desired, roll again on this table to see the source of the mistake. Perhaps a scholar mistranslated a diplomat's message and brought about a foolish war. Perhaps a scholar's research showed that a volcano's lava flow would move in the opposite direction. Maybe a prince was slain by a well-intentioned sword instructor which sparked oppressive activity by the king. Perhaps a government sent a gift to

a nearby force, who misinterpreted it as an insult due to cultural differences.

Nature: Roll on the Natural Disaster table on page 9. This natural cause weakened the civilisation and allowed a conqueror in, or perhaps the city's government made a plan for the survival of the wealthy but left the poor to die in the disaster – the survivors then rose up against them. Essentially a natural disaster occurs and either directly causes the end or causes the people to act in such a way that they effectively extinguish their own culture.

Noble: A noble (or the noble class in general) caused the cataclysm that ended or changed the civilisation. If desired, a trait may be rolled or chosen on the Agent Traits table.

Oppressed population (slaves, etc.) or person: Oppressed persons or populations brought about the cataclysm that ended the settlement or culture. Perhaps an angry slave weakened the barriers protecting the city from natural disaster, or an entire population of created monster-servants rose in revolt.

Religion: A new religion for the region arose or a new prophet became known. Perhaps an old religion is angry at a newer religion. The religion refuses to believe the gods are angry and ignores signs that nature is about to unleash its full force on the settlement. The religion may have preached superiority and 'the gods are on our side' so effectively that the people entered into a foolish war that doomed them. The religion may have decided the site had become holy and must be abandoned so the gods may live there alone.

Rival civilisation: The settlement or civilisation has a traditional rival who took advantage of some weakness or opportunity, or was driven by circumstances, to attack the culture now in ruins.

Ruler of civilisation: The ruler of the civilisation at the end may have been particularly weak and allowed the end event to happen. He may have simply made a mistake or had cause for vengeance. He may have been a strong leader who angered someone stronger. Roll for or choose an Agent Trait. Perhaps the death of the ruler brought about the end in the form of wars of succession, or the city was held together only by the charisma of the leader and when he died the populace abandoned the site out of despair or a desire to return to a former way of life, such as the fall of Egyptian Akhetaten, which was founded by Akhenaten and abandoned after his death.

Scandal: A horrible scandal rocks the civilisation; it may distract them from seeing the true threat or it may bring about the change that ended the civilisation in a more direct fashion.

Sorcerer: Through the summoning of demonic entities, tainting an area with Corruption or some other scandalous application of magic, a sorcerer has brought about some kind of disastrous event to the surrounding land.

Uncontrolled Cultural Trait: Roll for an Agent Trait. This trait applies in general to the entire population at the end, which ultimately caused its downfall. Perhaps the entire culture became slothful, such as in Xuthal, and just slowly died out due to indifference. Perhaps an envious culture decided to go to war in a pique of jealousy.

Agent Traits

d20	Trait
01-03	Anger
04	Envy
05-06	Deceit
07	Gluttony
08-09	Greed
10-11	Lust
12	Martyrdom
13-14	Pride
15-16	Sloth
17	Stupidity
18	Vanity
19-20	Zealousness

Anger: Event or person is or was motivated by anger, hate, vengeance or similar dark emotions. Someone may have dishonoured the agent or a tradition, for example. Anger may be related toward the actions of another agent of change (roll or choose a second agent if desired).

Envy: Event or person is or was triggered by envy, jealousy or similar dark emotions. Envy may be related toward the actions or possessions of another agent of change (roll or choose a second agent if desired).

Deceit: Event or person is or was triggered by deceit, fraud or worse. The Trojan horse is an example of cataclysm by deceit. Deceit may be related toward the actions or possessions of another agent of change (roll or choose a second agent if desired).

Gluttony: Event or person is or was triggered by gluttony, over-consumption, addiction or similar situations.

Greed: Event or person is or was triggered by greed, miser-like behaviour or other situation involving the hoarding of goods or services. Greed may be related toward the actions or possessions of another agent of change (roll or choose a second agent if desired).

Lust: Event or person is or was triggered by lust, sexual desires or attraction, all taken to an unhealthy or unnatural extreme. Lust may be related toward the actions or possessions of another agent of change (roll or choose a second agent if desired). This category could include incest or inbreeding.

Martyrdom: Event or person is or was triggered by sacrifice on the part of a legend or civilisation. Sacrifice may be related toward the actions or possessions of another agent of change (roll or choose a second agent if desired).

Pride: Event or person is or was triggered by pride, honour or similar notions. Pride may be related toward the actions or possessions of another agent of change (roll or choose a second agent if desired).

Sloth: Event or person is or was triggered by laziness, sloth and decadence. The Lotus-Eaters of ancient myth and the inhabitants of Xuthal are examples of cultures with this trait.

Stupidity: Event or person is or was triggered by stupidity, folly, ignorance or other situations where an ill-advised course of action was taken. Usually hindsight shows the stupidity of the action, but some follies are seen as ignorant even before the undertaking.

Vanity: Event or person is or was triggered by vanity or appearances. Perhaps the legend had her pretty face scarred forever, sending her on a crusade against the foes who damaged her. Vanity may be related toward the actions of another agent of change (roll or choose a second agent if desired).

Zealousness: Event or person is or was triggered by zeal, enthusiasm or similar feelings. Zealots are often religiously or morally motivated. Zeal may be related toward the actions or possessions of another agent of change (roll or choose a second agent if desired).

SAMPLE HISTORY

Using the tables shown, here is an example of how they might be used in preparing the history of an ancient ruin to be discovered by the Player Characters. The Games Master rolls an 11 on the In The Beginning table; this gives migration. He then decides to roll three Ancient Events & Periods, and rolls a 9, a 14 and a 19; grand edifice constructed, natural disaster and religion. Then he needs to know the end of the civilisation. He rolls a 6 – mass riots. Who caused the mass riots? The Games Master rolls on the Agent of Cataclysmic Change table with a 14; an oppressed population rioted. Just for kicks, he rolls once on the Agent Traits table and finds out the oppressed population were gluttons with a roll of a 7.

Thus, he has a skeleton history. Now he can fill in details, using the skeleton as inspiration. The settlement began when a group of people, migrating away from a distant land, settled on the spot of the eventual ruin (if he decides he wants a reason for the migration, he can roll on the Agent of Cataclysmic Change table again). The settlement grows and prospers, and somewhere along the line the great temple is built. Knowing that a group of oppressed people will later destroy the culture, he chooses this event to begin the oppression. Slave labour is used to build the great temple for an upper class. The upper class begins to exploit the lower classes. Later, a natural disaster occurs (rolling on the Natural Disaster table results in a 10 – lahar). A mountain in the distance explodes and a mudslide of pyroclastic materials and water rips along the river next to the ruin, burying much of the settlement. The people survive because of the grand temple, but it is mostly the upper class who live through the disaster. To protect themselves from future blasts, the people begin to worship the volcano. Eventually, they summon down a demon who promises to protect them in return for sacrifices. They install the demon into the great temple and begin to rebuild the city. People (from other settlements that did not survive so well) move into the city and become the new lower class of labourers.

Eventually the end comes. The oppressed lower classes, who judge a meal by quantity, not quality, are hungry and tired of feeding an upper echelon of priests who do nothing. After all, it is the demon that protects them. The lower classes revolt and, in a feast of gluttony, devour their rulers in cannibalistic rage. Without the priests to control it, the demon then slaughters the remaining cannibals. Any who survived now live as ghouls, ranging out from the ruin to find sources of grisly food.

PHYSICAL NATURE OF THE RUIN LAYOUT

All ruins have a 'floor-plan', so to speak. Is the ruin an oval or a sprawling mass built along the lines of the topography? Was the city centrally planned and built all at once or did it grow outward and upward from an earlier settlement? Perhaps two neighbouring hamlets grew until the cities they became met in the middle and merged. Do the streets converge on a central area or do they wind around like snakes? Roll once on the table below to come up with the basic shape of the ruin; roll an additional two times if it is a merged city to find the basic shapes of the two cities that grew together. If a merged city comes up a second time, then a third city was merged into it and a shape may have to be determined for that one as well. Then roll on the other tables to find out more about the overall layout.

Ruin Shape

d20	Shape
01	Circular
02	Hexagonal
03	Irregular Polygon
04	Merged City
05-06	Octagonal
07-09	Oval
10-11	Rectangular
12-14	Sprawling
15	Square
16-19	Topographic
20	Triangular

City Street Layout

d20	Street Layout
01-05	Courtyards
06-15	Meandering Streets
16-17	Straight Streets
18-20	Mixed Streets

Courtyards: The streets run around a pattern of courtyards, or there are no streets – just interconnecting courtyards of various repeated shapes (like a honeycomb). Roll on the city shape table to come up with a repeated shape for the courtyards. Often the courtyard shape is the same as the outer shape of the whole ruin. The ruins in *Pool of the Black One* are of this type.

Meandering Streets: These streets are a complete maze. The city had no preplanning whatsoever and was built haphazardly.

Straight Streets: The city was centrally planned and executed from the start. The streets are straight and often run toward a central point.

Mixed Streets: The city has one or two well designed streets running to a central point, but the side streets and alleys are more haphazard and meandering.

Ruin Defences

d20	Defence
01-12	Walled
13-15	Walled & Roofed
16-20	Unwalled

Walled: The ruin has the remains of a defensive wall around it. The wall may have been earthen, stone or wooden. The wall may or may not still be there.

Walled and Roofed: The ruin is built as a large palace with walls and a huge roof (sometimes with spires and domes sprinkled throughout). Green stone ruins commonly have this design. Xuchotl is one of many examples of this sort of construction in the *Conan* tales.

Unwalled: The ruin never had an actual wall. It may have been built on cliffs or otherwise did not need a wall.

SIZE OF THE RUIN

Some issues with layout include the size of the ruin. Is it an abandoned hamlet? Is it the remains of a great metropolis? Keep in mind that the size of the ruin may not be indicative of the size of the original city. People may have carted off the stones of the ruins to build newer cities or monuments, leaving the ruin much smaller than it might otherwise have been. The ruin may be so old that most of it has crumbled into the soil. Parts of the ruin may be buried or overgrown, hiding the true size of the ruin. Ruins may also be layered. Civilisations sometimes build on top of the ruins of older civilisations; the ruins in *Drums of Tombalku* are of this type. Sometimes the manner of the end may suggest something in regards to the size of the ruin.

Size of Ruin

d20	Size of Ruin
01-04	Small
05-08	Small Remnant of Larger City
09-10	Small Old Ruin within Larger Ruin of Later Culture
11	Medium
12-13	Medium Remnant of Larger City
14-15	Medium Old Ruin within Larger Ruin of Later Culture
16	Medium Old Ruin with Small Ruin of Later Culture Within or On Top
17	Large
18	Large Ruin of Elder Culture with Small Ruin of Later Culture Within or On Top
19	Large Ruin of Elder Culture with Medium Ruin of Later Culture Within or On Top
20	Large Ruin of Elder Culture with Multiple Ruins of Later Cultures Within or On Top

STATE OF THE RUIN

Keep in mind that the overall state of the ruin does not necessarily indicate the state of selected features. A ruin that is overall a crumbling wreck may contain an aqueduct that is perfectly preserved, or a ruin that is largely preserved may have a central pyramid that has crumbled into a large powdery mound.

A ruin may also have more than one state. If desired, roll percentile dice to determine what percentage of the ruin is in one state or another. Sometimes the manner of the historical end of the culture that built the ruin may suggest something in regards to the state of the ruin.

State of Ruin

d20	State of Ruin
01-02	Barely There
03-04	Blasted Apart
05-06	Buried, fully
07-08	Buried, partially
09-10	Crumbled
11-12	Flooded
13-14	Overgrown
15-16	Sinking
17-18	Toppled
19-20	Well-preserved & Intact

Barely There: Most of the stones and building materials have either been carted off or crumbled into nothingness. All that is left are the foundations of ancient structures and buildings.

Blasted Apart: The ruins have the appearance of having been blasted into a scatter pattern, perhaps because something exploded in the centre of the ruin or a nearby volcano knocked everything down when it exploded.

Buried, fully: The ruin is buried in rubble, mud, ash, sand or other debris; all that can be seen (if anything) are the tops of the tallest buildings.

Buried, partially: Only part of the ruin is buried. Perhaps the ruin was built next to a cliff and a landslide buried 70% of the village. Roll a percentile to determine how much of the ruin is readily accessible.

Crumbled: The ruins are particularly overcome by the ravages of weather and time. If the ruins are particularly crumbled, then every 10 minutes (real time) any characters moving around in them must make a Reflex save (DC 15) or take 1d4 blunt damage from falling debris. If the character rolls a natural 1 he takes damage and twists his ankle, reducing his movement speed by 10 feet per round until someone takes the time to make a Heal check (DC 20). Less decayed ruins may have a longer time increment between Reflex saves.

Flooded: Similar to buried, the ruin may now be in the middle of a lake or river, flooded partially or fully.

Overgrown: Nature has fought back against the attempt at civilisation and has retaken the ruin. Trees, grass, vines and other growth covers the ruins, hampering movement

(see movement in *Conan the Roleplaying Game* for hampered movement rates and rules).

Sinking: The ruin is sinking into a massive sinkhole or bog. The edge of the sinkhole or bog may give a natural threshold to the ruin (see the Threshold entry under the Weird Elements table on page 23).

Topped: Almost all the features of the ruin are knocked over, possibly because of an earthquake or a giant monster, if not just sheer gravity.

Well-preserved & Intact: The ruin is almost perfectly preserved, exactly as it was during its prime. The ruin may be a recent ruin, its inhabitants merely vanished, or it may have a caretaker. The preservation may be supernatural or simply unexplained.

RUIN COLOUR

The ruins of the Hyborian Age sometimes have colours associated with them. Acheronian ruins are purple and another cultures left green ruins. The ruined tower found in *Drums of Tombalku* is red. The Hyborian Age is an age of glittering cities, with coloured domes and spires. The ruins can display some of the same decadent forms to give it an eldritch feel. Particular features may have varying colours from the normal associated colour; for example, a green stone city may have a red central tower.

Colouration

d20	Colouration
01-02	Black
03-04	Blue
05	Gold
06-07	Green
08-09	Natural Colouration
10	Orange
11	Polychromatic
12-13	Purple
14-15	Red
16	Silver
17-18	White
19-20	Yellow

CULTURAL REMNANTS IN THE RUINS

Basically, there are two types of cultural remains in a ruin: artefacts and features. Artefacts are small, portable items created by a culture, such as tools, instruments, bowls and figurines. Features are larger, non-portable creations of a culture, such as walls, tombs, roads, wells, kilns, ports and

aqueducts. Roll a d20 on the appropriate table or choose an artefact or feature as desired. Roll or choose as often as needed. This list is not intended to be comprehensive, but should serve as a starting point.

Artefacts

Artefacts may be out in the open, or they may be hidden by debris, dirt or garbage. Many cultures are identifiable only by their distinctive artefacts. The Player Characters may not know the name of the culture of a given ruin, but when they come across the same type of artefact in a later ruin, they may connect the two as being the same culture, much like the 'green stone city' builders who left such distinctive ruins throughout the Hyborian Age lands. Try to give the artefacts a distinctive flair or flavour so that later encounters with similar artefacts create a feeling of continuity, even if the name of the culture is never known. Artefacts may be found intact or damaged to varying degrees.

Artefacts

d20	Artefact Found
01	Armour
02	Arrow Heads
03	Biofact
04	Buttons
05	Burial Goods
06	Clay Tablets
07	Clothing
08	Coins
09	Furniture
10	Gemstones
11	Jewellery
12	Musical Instruments
13	Personal Artefacts
14	Pottery Vessels
15	Recreational Artefacts
16	Religious Artefacts
17	Scrolls
18	Sorcerous Artefacts
19	Tools
20	Weapons

Armour: Armour can be made out of bronze, primitive, alien, superior or normal materials; roll or choose from the tables in *Conan the Roleplaying Game* or its supplements). Alternatively, custom armour can be designed to reflect the alien nature of the culture that built the ruin. Player Characters might find battered shields in the dirt with ancient symbols of power on them, their meanings long forgotten.

Arrow Heads: Arrow heads usually outlive the arrows they were once



attached to. They may be made of stone, bronze, iron, steel or some alien material.

Biofacts: Biofacts are the remains of old inhabitants. These might include the scorched bones of sacrificial victims, piles of skulls from war victims or mummies.

Buttons: Buttons are often made from materials that far outlast the clothing they were attached to.

Burial Goods: This includes coffins, ushabtiu figurines, masks, steles, jewellery, clothing, weapons and other personal belongings or ritual items buried with the dead.

Clay Tablets: Ancient cultures often wrote important information on hardened clay tablets. These include religious writings, myths & legends, spells and accounting information. Most clay tablets found will have accounting information on them. Some additional topics include: architecture, engineering, astronomy, astrology, mathematics, medicine, medicinal weeds & herbs, gem properties, numerology,

heraldry, legends, folklore, history, law, customs, philosophy, trees, geography or alchemy.

Clothing: Usually found in burial chambers and tombs, clothing tends to deteriorate and is not often found intact or in a recognizable format. However, the survival of clothing is not unheard of. The existence of clothing stores in a ruin may be a hint that someone lives there or routinely visits – perhaps to change the clothing of a goddess' statue.

Coins: Coins of various metals, denominations and nationalities may be found. Not only might the culture's coins be found, but also the coins of anyone the culture traded with or raided.

Furniture: Most wooden furniture will not survive from ancient periods unless stored in a dry location. This category would include thrones, chairs, tables, shelving, daises, fountains and the like. Truly fantastic furniture may be carved from massive, legendary gemstones (such as a throne carved from a single, monstrous ruby).



Gemstones: Gems are mined and used for ornamentation or money. Gemstones include: Banded, eye, or moss agate, azurite, blue quartz, hematite, lapis lazuli, malachite, obsidian, rhodochrosite, tiger eye turquoise, freshwater (irregular) pearl, bloodstone, carnelian, chalcedony, chrysoprase, citrine; iolite, jasper, moonstone, onyx, peridot, rock crystal (clear quartz), sard, sardonyx, rose, smoky, or star rose quartz, zircon, amber, amethyst, chrysoberyl, coral, red or brown-green garnet, jade, jet, white, golden, pink, or silver pearl, red spinel, red-brown or deep green spinel, tourmaline, alexandrite, aquamarine, violet garnet, black pearl, deep blue spinel, golden yellow topaz, emerald, white, black, or fire opal, blue sapphire, fiery yellow or rich purple corundum, blue or black star sapphire, star ruby, clearest bright green emerald, blue-white, canary, pink, brown, or blue diamond and jacinth.

Jewellery: Jewellery includes ornamentation made from metals (often precious) and smaller gemstones. Jewellery typically includes such items as: anklets, armbands, small boxes, bracelets, brooches, buckles, chalices, clasps, coffers, combs, crowns, decanters, earrings, goblets, headbands,

loquets, medals, medallions, necklaces, pendants, pins, orbs, rings, sceptres, hairpins, seals and tiaras. They can be made of ivory, wrought silver, silver and gold, gold, jade, wrought platinum, silver, or any of the previous materials in combination with various gems or semi-precious stones.

Musical Instruments: Musical instruments made of metals may easily survive intact in a ruin. Wooden instruments will usually only survive if stored in a dry location. Examples include: harps, lutes, horns, trumpets, drums, shawms, psalteries and tabors.

Personal Artefacts: Personal artefacts include combs, goblets, fetishes and so forth. Truly fantastic personal artefacts may be carved from huge gemstones (such as a goblet carved from a single, diamond) or be made of precious metals or inset with small gems and stones. Personal artefacts can include such items as: wooden bowls; leather costrels; leather drinking-jacks; clay jugs; clay mug/tankards; pewter mug/tankards; braziers; lamps; candles; iron pots; waterskins; barrels; chests; buckets and baskets.

Pottery Vessels: Pottery vessels include amphorae. Pottery may be intact or broken into bits and may hold scrolls, weapons, herbs, bones, treasure or anything else desired.

Recreational Artefacts: Recreational artefacts are the remnants of games and sports once played by the culture, which may include sports equipment or game boards and pieces. Often the rules are never recorded anywhere, so the manner of playing the sport or game is lost to the mists of time, which could be unfortunate if the clue to bypass a trap is to give the appropriate answering move in one of these old games.

Religious Artefacts: Religious artefacts include candelabra, chimes, altar cloths, masks, drums, idols, statues, mosaics, benches, incense and anything else that might be found in a temple.

Scrolls: Ancient cultures often wrote important information on scrolls. These include religious writings, myths & legends and spells. These are more perishable than clay tablets and if not stored in a dry place will deteriorate quickly; thus, they are not likely to be found in ancient ruins other than those found in deserts. Some additional topics include: architecture, engineering, astronomy, astrology, mathematics, medicine, medicinal weeds & herbs, gem properties, numerology, heraldry, legends, folklore, history, law, customs, philosophy, trees, geography or alchemy.

Sorcerous Artefacts: Any artefact involving sorcery, witchcraft or medicine. These could include dolls, tools, shrunken heads, wands, staffs, candles, magic formulae, altars, lotus, herbs, masks, alchemical equipment and other paraphernalia.

Tools: Tools can be made of stone, metal and/or wood, although stone ones will last longer. Wooden tools, or tools with wooden portions, are unlikely to be found in ancient ruins in certain environments. Tools include most farming artefacts and crafting artefacts.

Weapons: Weapons can be made out of bronze, primitive, alien, superior or normal materials; roll or choose from tables in *Conan the Roleplaying Game* or its supplements). Alternatively, custom weapons can be designed to reflect the alien nature of the culture that built the ruin. This category includes most war artefacts, including chariots and war machines.

Features

Features are sometimes found in a ruined state but not always. Features may be buried,

overgrown, toppled or they may still be standing erect. They may be inside a building, moved from its original spot or have missing pieces (stolen or broken off over the years). A feature could be sinking, leaning or crumbled into boulders. After rolling a few random features, choose or roll for the state the feature is found in on the State of Feature table. Features are not portable and tend to be heavy. As an option, choose a size, or roll a size randomly on the Size of Feature table, discarding any rolls that do not make sense. Features are rarely found completely intact.

Features

d20	Feature
01	Altar
02	Aqueduct
03	Bell
04	Building Remnants
05	Canal
06	Cemeteries
07	Docks & Piers
08	Fountains
09	Grinding Slabs
10	Hearth
11	Kilns
12	Middens
13	Ornamental Objects
14	Plazas
15	Pools
16	Roads
17	Stairways
18	Tombs
19-20	Walls

Altar: An altar is a structure where offerings and sacrifices are given or dedicated to the god or gods of the culture. Altars are often erected in high places because they are closer to the gods (or in especially low places if the gods are believed to reside underground).

Aqueduct: An aqueduct is a raised channel to carry water. Aqueducts may still be functional or they may have fallen into disrepair and/or disuse. This category can also include viaducts, which are raised roads.

Bell: Large bells may still be up in their towers and belfries or they may have fallen to the ground.

Building Remnants: These include pavilions, stalls, barns, sheds, houses, temples, civic buildings, barracks, cisterns, coliseums, corrals, granaries, inns, libraries, mills, offices, shops, stables, taverns, tenements, theatres, warehouses and

workshops. Sample ruined buildings and temples can be found throughout this book. Virtually any map of any city or structure can be turned into a map of a ruin with a bit of imagination.

Canal: The canals may still be filled with water, or they may have long since dried up. Some may have collapsed. They can impede movement and some may have bridges built over them. This category also includes smaller irrigation ditches.

Cemeteries: A cemetery is where the culture buried its dead. It may contain tombstones, tombs, mausoleums, obelisks, walls, arches and gates.

Docks & Piers: These constructions are likely not safe and may even have sunken ships attached to them or near them.

Fountains: Fountains are ornate water displays.

Grinding Slabs: Although the mills may vanish, the great stones that grind grain into meal are often left behind, as are stones used to sharpen implements or the smaller stones used in kitchens or around the hearth.

Hearth: A hearth is a brick- or stone-lined oven used for cooking or heating a building. They are often left behind long after the structure itself is gone. Even ancient campsites may leave a cooking pit or hearth behind for later generations to find. Fish and animal bones are often found around the remains of hearths (or if the people are cannibal, human bones). Although bone usually disintegrates fairly quickly normally, fire-hardened bone can last an extremely long time.

Kilns: Kilns are similar to hearths in that they are ovens, but a kiln is usually larger and is used for drying materials, such as pottery, converting wood into charcoal or strengthening steel.

Middens: Middens are basic waste dumps. Every culture has waste and few find anything useful to do with it, so they create dumps. Middens include shell mounds as well as simple kitchen waste dumps.

Ornamental Objects: Ornamental objects include monuments, large statues, fountains, idols, frescoes, obelisks, paintings, mosaics and other artful features

Plazas: A plaza is an open public space. Trees or other vegetation may have grown in a plaza or courtyard and may make identification difficult. Some plazas were paved, either with stones or even with artful mosaics.

Pools: Pools may or may not have water in them as a ruin. This category includes baths, bird baths or reflecting pools.

Roads: Roads are pathways used by people to travel.

Stairways: Stairways, especially those made of stone or cut into stone, often remain behind after the rest of the ruin has disappeared or crumbled away. Ruined stairways are often dangerous (see Movement Within Ruins, page 22).

Tombs: A tomb is a burial vault with walls, a roof and sometimes a door. Some tombs are not located in cemeteries but may be located beneath a building, plaza or other structure. The ruin may be nothing but a tomb. A crypt is a tomb beneath a temple. A dolman is a megalithic tomb with the large stones set in formation, creating a single chamber; although they are often covered in earth or smaller rocks, time often exposes the megalithic skeleton of the dolman. Some cultures do not use tombs, but bury their dead, either in individual graves or in mass graves.

Walls: Broken battlements and walls typify many ruins. This category includes architectural features such as arches, pillars and columns.

Size of Feature

d20	Size
01	Tiny
02-03	Small
04-08	Medium
09-11	Large
12-14	Huge
15-17	Gargantuan
18-19	Colossal
20	Cyclopean

Tiny: These are features that are one to two feet in general dimensions. Tiny features may be miniaturised versions of larger features or may be actual features (such as statues) that are either attached to something larger or so heavy as to be unmoveable; otherwise, the tiny feature is actually an artefact.

Small: Small features are generally two to four feet in general dimensions (height or length). Small features may be miniaturised versions of larger features or may be actual features (such as statues) that are either attached to something larger or so heavy as to be unmoveable; otherwise, the small feature is actually an artefact.

Medium: Medium features are between four and eight feet along one dimension and weigh between 60 and 500 pounds.

Large: Large features are between 8 and 16 feet along one dimension and weigh between 500 pounds and two tons.

Huge: Huge features are between 16 and 32 feet along one dimension and weigh between 2 and 16 tons.

Gargantuan: Gargantuan features are between 32 and 64 feet along one dimension and weigh between 16 and 125 tons.

Colossal: Colossal features are in excess of 64 feet along one dimension and weigh more than 125 tons.

Cyclopean: A Cyclopean feature is so massive it defies the imagination. A Cyclopean grinding stone, for example, might have a 600 foot diameter and be made of a single block of stone.

State of Feature

d20	State of Feature
01	Blasted Apart
02	Buried
03-04	Crumbling
05	Encrusted
06	Intact
07	Mismatched Pieces
08-10	Missing Pieces
11-12	Overgrown
13-14	Sinking or Leaning
15	Standing Erect
16-17	Toppled, Broken
18-19	Toppled, Intact
20	Weathered Badly

Location of Feature

d20	Location
01-05	Inside a Building
06-10	Inside but Moved From Its Original Spot
11-15	Outside
16-20	Outside but Moved From Its Original Spot

Distinctive Flair & Motifs

Most artefacts and features in a ruin should have some sort of cultural flair to make the items unique to the culture. It is hard to describe architectural styles but it is often fairly easy to describe recurring patterns, such as the serpentine pattern repeated in Epemitreus' tomb in *Phoenix on the Sword*. Celtic knot work and Egyptian hieroglyphs can also quickly give a cultural feel to a location.

The list below is a small sampling. A bit of research can turn up thousands of other options.

Flairs & Motifs

d100	Flair or Motif
01-03	Arabesque Vine Scrolls
04-06	Buttresses
07-09	Circles
10-12	Clustered, Slender Columns
13-15	Colonnades
16-18	Domes
19-21	Elaborate Windows
22-24	Friezes
25-27	Groin Vaults
28-30	Hieroglyphs or Writing
31-33	Honeycomb Patterns
34-36	Knot Work
37-39	Massive Pillars
40-42	Megaliths
43-45	Minarets
46-48	Monoliths
49-51	Mosaics
52-54	Obelisks
55-57	Parallel Mullions (vertical bars of stone)
58-60	Phallic Designs
61-63	Pointed Arch (lancet)
64-66	Porticos
67-69	Pylons
70-72	Recesses
73-75	Religious Motifs
76-78	Repeated Animal Designs
79-81	Rope Patterns
82-84	Shrunken Heads
85-87	Skulls
88-90	Step Forms
91-93	Terraces
94-97	Yoni Designs
98-100	Zigzag Forms

MOVEMENT WITHIN RUINS

Ruins are not always stable. Time has eroded much, although some ruins manage to survive with more tenacity than others. If the ruins are particularly decayed, then every 10 minutes (real time) any characters moving around in them must make a Reflex save (DC 15) or take 1d4 blunt damage from falling debris. If the character rolls a natural 1 he takes damage and twists his ankle, reducing his movement speed by 10 feet per round until someone takes the time to make a Heal check (DC 20). Less decayed ruins may have a longer time increment between Reflex saves.

Undergrowth: Many ruins have undergrowth, broken masonry and other impediments to movement. Follow normal rules in *Conan the Roleplaying Game* for hampered movement in a ruin, which will usually have Difficult Terrain or Obstacles.

Dense Rubble: The ground is covered with rocks of all sizes. It costs 2 squares of movement to enter a square with dense rubble. The DC of Balance and Tumble checks on dense rubble increases by +5, and the DC of Move Silently checks increases by +2.

Light Rubble: Small rocks are strewn across the ground, making nimble movement more difficult. The DC of Balance and Tumble checks increase by +2.

ALIEN NATURE OF THE RUINS

Many of the ruins in *Conan the Roleplaying Game* have an atmosphere of weirdness, an alien air that makes characters uncomfortable. Ultimately the laws of reality have broken down, creating a nightmarish environment, a twisted shadow of reality. Listed below are some sample ideas. Roll for 1d6 Weird Elements or choose the elements that best fit the concept.

Weird Elements

d20	Weird Element
01-02	Element of Horror
03-04	Element of Madness
05-06	Soporific Flora
07-08	Threshold
09	Unexplained Actions
10-11	Unexplained Appearances
12-13	Unexplained Disappearances
14	Unexplained Scents
15-16	Unexplained Sights
17-18	Unexplained Sounds
19-20	Unnaturally Quiet

Element of Horror: The ruins may contain some inexplicable element of horror. Those who look upon them must make a Terror check (DC 15). Characters that succeed do not normally need to make the check again. Characters that fail receive a -2 penalty on attack rolls, saving throws, skill checks and ability checks, and flees from the area as quickly as possible. If the area has an active horrific effect (i.e. it restores itself to its former grandeur during the night hours) then character's that formerly succeeded must make a second Terror check. This effect remains until the character leaves the ruined site for at least 24 hours.

Element of Madness: The ruins are so alien or so horrific they contain an inexplicable element of madness. Those who remain within the ruins or stare at the ruins overlong (time varies with each ruin) must make a Will save (DC 15). Characters that succeed do not need to make the check again for another 24 hours of contiguous time within sight of the ruin. Characters that fail suffer permanent madness - typically the characters suffer monstrous nightmares for the rest of their shortened days, dying with the froth of madness on their lips. The nightmares do not allow the character to sleep, so he slips into fatigue for 1d3 days. A fatigued character can neither run nor charge and takes a -2 penalty to Strength and Dexterity. Doing anything that would normally cause fatigue causes the fatigued character to become exhausted. An exhausted character moves at half speed and takes a -6 penalty to Strength and Dexterity, and to all Listen and Spot checks. If the nightmares are not stopped, the character will die frothing at the lips within 1d6 days. Alternatively, the Games Master can assign a permanent madness of a type described in *Conan the Roleplaying Game*.

Soporific Flora: The ruin's flora has a soporific effect on those who pass beneath or ingest it. The target must make a Fortitude save (DC 20) or fall into slumber for 2d4 hours. During this time the affected character may have visions of the past or the future. The ruin's monster or monsters will act against all affected characters, executing diabolical plans that usually involve some grisly sacrifice. The flora, instead of putting targets to sleep, may cause hallucinations or paranoia. Be careful to vary the effect in order to surprise and unnerve the Player Characters, and to give the ruin a unique character.

Threshold: The ruin is surrounded by some threshold feature that is unusual in some way. The ruin may be surrounded by a clearing that is perfectly circular, a perpetual fog bank, a region of complete desolation in an otherwise verdant locale, huge stands of trees in a desert, a colossal wall built to keep whatever lurks in the ruin away from outside villages, massive cliffs, tar pits or any other feature desired. This should be a feature that gives Player Characters a reason to pause and consider whether they should cross the proffered threshold. A threshold feature serves to give notice that the characters will be moving into an area out of the ordinary.

Unexplained Actions: The Player Characters must make a Will save (DC 20) or be forced to attempt to rebuild the ruin, re-enact the fall of the ruin or a legendary figure, run screaming to a precipice, start chanting or any other bizarre and potentially dangerous activity.

Unexplained Appearances: Things suddenly appear without warning or discernable cause: a tree that was not there a few moments ago; a building that was not there the

last time the Player Characters crossed the plaza; a hallway that was not there the last time they passed by the location; and other weird events.

Unexplained Disappearances: Things belonging to the Player Characters vanish without a trace. They may or may not reappear later. Things that may disappear without explanation to unnerve the characters include equipment, weapons, clothing, food, animals, Non-Player Characters (never Player Characters!), features or artefacts.

Unexplained Scents: The characters smell an overpowering scent that does not have any discernable source. The smell might be a perfume-type smell, an acrid smell, a chlorine smell, a mouldy smell, a manure smell, a bad body-odour smell, a putrid smell or any other smell desired.

Unexplained Sights: This is a typical element found in many 'haunted' locales: shadows out of the corners of the eye; people who appear, then vanish without a trace, the sight of completed buildings in the distance, visions of the past, ghosts, objects moving of their own accord and other visuals. The visuals are almost always related to the history of the ruin.

Unexplained Sounds: This is a typical element found in many 'haunted' locales: the garbled sound of people talking; moaning breezes or winds, bangs and slams, weird bellowing, unnerving giggling, footsteps, coughing, crashing, thumping, screaming, rattling of chains, laughter, scratching, horns blowing, howling, hissing or grunting.

Unnaturally Quiet: There is virtually no sound in the ruin save the sounds made by the Player Characters. They cannot hear birds chirping, monkeys chattering or anything else. This can be especially unnerving if the ruin is located in an otherwise noisy environment, such as a jungle. Perhaps it is a supernatural effect or perhaps the animals know better than to make noises in the presence of the ruins. Regardless, the lack of natural ambient noises can create an unnerving atmosphere for Player Characters; also, do not feel obligated to explain the reasoning for the lack of sound.

MAGIC & UNUSUAL ITEMS HIDDEN IN THE RUINS

Generally speaking, magic & unusual items should never appear in a *Conan the Roleplaying Game* adventure unless they have a story-related reason for being

there – they should never just be random loot or another part of the treasure, as many other fantasy roleplaying games handle magic items.

That said, ruins are places of legend and tales of fabulous wealth lying in state within the ruin circulate throughout the known world. Great treasure can be a fabulous story hook to get Player Characters to enter the ruins despite the obvious dangers.

LEGENDS REGARDING THE RUINS

A ruin often has legends attributed to it, especially by those who live relatively near to them. These legends are occasionally tested by youths on dares who regard the testing of a ruin as a rite of passage. Other legends serve as warnings to keep intruders away (especially when they desperately need shelter) and yet others provide the hook to bring the Player Characters to the ruin (especially when they do not have a reason to leave wherever they are). Most legends revolve around horrid monsters, lingering deaths and fabulous treasures. Most often the legend is linked either to the factual history of the ruin or the history of a place near the ruin.

MONSTERS & GUARDIANS OF THE RUINS

Ruins in the Hyborian Age are rarely are simply dormant sites of previous habitation. Hyborian Age ruins generally have a creature (human, demonic or monstrous) in residence and usually an ancient remnant from a forgotten history. Every encounter with a ruin should have some sort of entity or guardian involved somewhere.

The monster guardian does not even have to be a 'monster' in the normal sense. A disease can also guard a ruin or the ruin could cause characters to mutate into something else. Curses and spells protecting a location can also be the 'monster', such as the noxious gas contained by a shaman's spell in *The Black Stranger*.

The monsters and guardians of a ruin are usually the last of their kind in Howard's tales; they cannot replace themselves or replenish their race. If the Player Characters clear out the ruin, they will slay the last living evidence of a forgotten age.

Monsters & Guardians

d20	Monster/Guardian
01-02	Body Horror
03	Curse
04-05	Demon
06	Demon, Multiple, plus Leader
07-08	Mutated Monster
09-10	Mutated Monsters, Multiple, plus Leader
11-12	People, plus Leader
13	Person
14-15	Sorcerer
16	Sorcerers, Multiple, plus Leader
17-18	Undead, Multiple, plus Leader
19-20	Undead, Single

Body Horror: The ruin is protected by an infectious disease, Corruption or some other agent that changes the body. The characters have to make Fortitude saves (DC 18 or against the Disease infection DC) at regular intervals to avoid catching the horror. Perhaps the ruin is so alien and horrible that every three rounds the characters have to make a save to avoid gaining another point of Corruption – if they linger too long, they can become so corrupted they never want to leave or are unrecognisable as human. Perhaps an eyeball will start to grow from a person's shoulder, or an extra arm. It could be something so trivial as their hair turning permanently white or they gain a permanent twitch in a body part. Perhaps the twitch is tuned to a word or an event – every time someone says 'Acheron' the person begins to speak in tongues or his eye starts twitching whenever he sees a certain rune.

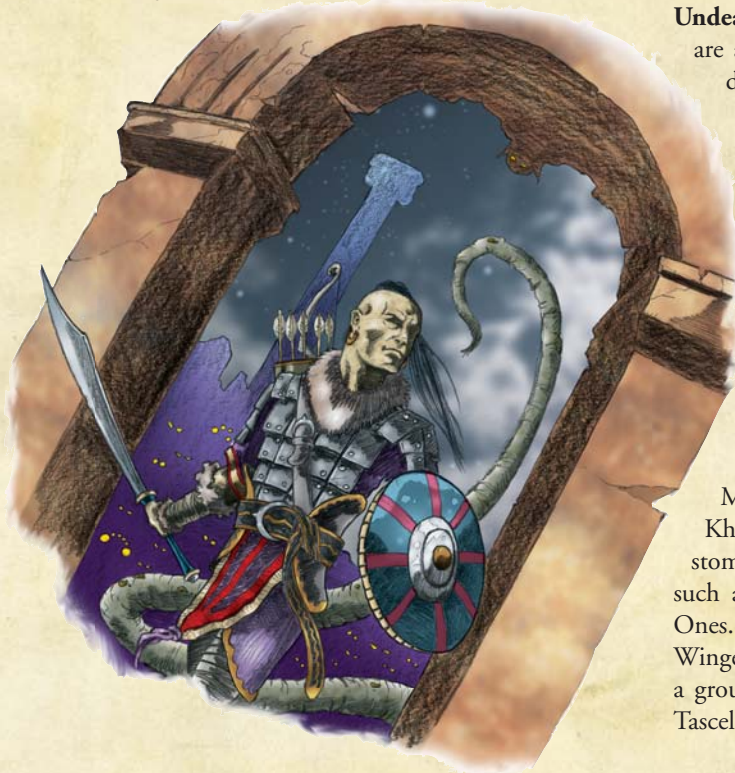

Curse: The ruin is protected by a curse. The ruins of the City of Brass in *Conan and the Grim Grey God* (by Sean A. Moore) was protected by a curse that would turn an intruder into sand (this is also an example of body horror). The treasure of Trancos in *The Black Stranger* was also protected by a curse. Perhaps a location is protected by a magical barrier or the awful rite of the werebeast.

Demon: Many ruins are host to a demon or demon lord. Thog of *Xuthal of the Dusk* and Khosatral Khel of *The Devil in Iron* are examples.

Mutated Monsters: The monsters of the ruins in Robert E. Howard's stories are unique beings. There are sample monsters in the bestiary of this volume as well as monsters in the other *Conan the Roleplaying Game* sourcebooks. Making unique monsters out of those is a relatively easy process. The easiest thing to do is to add wings to a monster or animal or add talons, prehensile tails or any other feature that would make the creature stand out as unique. Various templates can add variety to otherwise mundane animals or monsters. In addition to templates, a Games Master might consider simply adding Corruption to the monster (see *Conan the Roleplaying Game*). The Winged One from *Queen of the Black Coast* is an example of a mutated monster. See Monsters of the Ruins on page 137 for a random method of making standard monsters more unique.

Sorcerer: Sorcerers also may live in a ruin – and, like Thugra Khotan of *Black Colossus*, may arguably be undead. Tascela of *Red Nails* is another example of a sorcerer in a ruin.

Undead: In addition to altered monsters, undead creatures are also an option for ruins. Vampires, mummies, risen dead and other creepy fiends can easily be imagined lurking in a dank tomb, locked away and forgotten for ages.

People: People may also live in a ruin. They may be the decadent descendants of the builders, such as the Xuthalans from *Xuthal of the Dusk*, or they may be squatters, such as the Tlazitlans in *Red Nails*. Often, the people living in these ruins have lived ghastly lives and, because they probably have a sorcerous or demonic leader, have various levels of Corruption applied to them.

Monsters and guardians can be singular, such as Thugra Khotan, alone in their crypts and haunting their stomping grounds. They can be groups of creatures, such as the Xuthalans, the Tlazitlans or the Black Ones. Groups require a leader, much like how the Winged One of *Queen of the Black Coast* led a group of werebeasts. Leaders such as Tascela are usually sorcerous.

Cultures & Ruins

WHAT KINDS OF ruins might be found in Nemedea? Are they different than ruins found in Brythunia? This chapter discusses the typical types of ruins that might be discovered amid the various cultures and kingdoms of the Hyborian Age. Each section has some historical elements gleaned from the *Conan* saga to help place the ruins or to create specific artefacts.

AQUILONIA

Aquilonia is the wealthiest and most powerful of the Hyborian kingdoms, peopled with a proud population better off than most in that distant epoch. In Conan's time, Aquilonia most closely resembles medieval France in culture and ecology. Its barons and counts maintain ancient feuds from generation to generation and the frontiersmen fight Picts, Cimmerians, Nemedians, Ophireans and each other. Aquilonia plays a dominant role in the history of Robert E. Howard's world.

Aquilonia is the scene of much history, for ancient Acheron once existed over much of central and eastern Aquilonia. Ruins of Acheron certainly exist, hidden away in hills and nestled in secret places. Some of the ancient homes of the Acheronians were so devastated by the Hyborian barbarians that today the ruins may resemble little more than mounds or hills; someone digging to unearth some buried treasure may unleash untold horrors upon an unsuspecting populace.

Ruins can be Acheronian or Aquilonian in origin. Aquilonian ruins are often castles that have fallen into disrepair or disuse because of the feudal nature of the land. Cities that have been abandoned or ruined often have mitraeums (see below) that last longer than most of the houses and are a common ruin feature. Valusian ruins might be encountered, although this would be an extraordinary discovery as most Valusian remnants would have been utterly wiped away by the Great Cataclysm. It is more likely that a Valusian artefact, kept as a religious item by a Pictish or Cimmerian tribe would be found than an entire ruin.

Mitraeums

Mitraeums, the sanctuaries of Mitra, are usually in caves, which represents an empty tomb and the promise of eternal life offered in the Mysteries of Mitra. The chapels are small and each

brotherhood has a maximum of 100 members. If it exceeds that, another mitraea is established. These temples are places where devotees can feel close to divinity and have religious and mystical experiences.

The mitraeum is usually rectangular, often around 75 feet by 30 feet with a vaulted ceiling. The walls, ceiling and floor are white marble. A gold frieze often runs along the walls, decorated with scenes from the life of Mitra. An aisle runs down the centre of the temple and a stone bench runs along either side for the cult's members to sit upon. Most mitraea hold around twenty or thirty people comfortably. Behind an altar of clear green jade, unstained with sacrifice, stands the pedestal whereon sits the idol of Mitra. He is shown with magnificent shoulders, clear cut features, wide straight eyes, a patriarchal beard, the thick curls of his hair confined by a simple band about the temples. Behind the altar and the image of Mitra, is a wall carving depicting Mitra slaying a scarab.

The Mitran religion frowns upon ostentatious religious displays, and their temples idealise this thought in their relatively symbol-free architecture. Mitra's temples are awesomely plain, yet stately, artistic and beautiful despite the lack of ornate symbols and massive, sweeping structural forms so prevalent in most Hyborian Age temples. The altar is a symbolic gesture at best, for the Mitran religion does not sacrifice humans or animals to their omnipresent deity. A single dignified statue is likewise permitted, but is not worshipped. Any statues of Mitra are considered attempts by the faithful to visualize Mitra in an idealized form, for his true form is unknowable. No one pretends to know what Mitra looks like and he is not believed to inhabit idols (like Shemites are taught about their gods).

Historical Elements: Prior to the Cataclysm, the realms of Valusia occupied this space. A thousand years after the lesser cataclysm, Acheron firmly occupied this area. Aquilonia was founded 2,500-3,000 years ago after the fall of Acheron. Andromedus began feudalism in Aquilonia approximately 2,000 years ago. Epemitreus the Sage brought the religion of Mitra to Aquilonia fifteen hundred years ago. Nine hundred years ago Epeus the sword-wielder ruled Aquilonia. Somewhere around five or six hundred years ago Poitain became part of Aquilonia. Conan strangled Numedides (also spelled Namedides) and usurped the throne. Prince Arpello ruled briefly during the events of *The Scarlet Citadel* and

Prince Valerius ruled briefly during the events of *The Hour of the Dragon*.

Known Kings of Aquilonia: Andromedus, Epeus the Sword-wielder, Vilerus, Numedides (also spelled Namedides), Conan, Arpello, Valerius, Conan II.

KARUTONIA (RUIN)

The ruins of Karutonia, a great city of Acheron once lived in by a million people, can be found in the foothills of the Border Range on the Aquilonian side. The Aquilonian town of Croton is built upon these ruins, which appear to be low hills, covered in earth and vegetation.

Cultural Type: Acheronian.

Historical Nature: The Acheronian city of purple towers was founded between 5,000 and 4,000 years prior to the reign of King Conan. The city was founded upon broken Valusian ruins. It grew to the size of a metropolis, housing over a million people and was largely a market city linking east and west Acheron. It fell when the Hyborians sacked Acheron as a whole.

Physical Nature: The ruins are so ancient they are nothing more than large hills. It was a sprawling city with meandering streets, although virtually all of it is buried now. Most of the ruins are a shade of purple. Miners and explorers have occasionally unearthed strange artefacts from the ruin, including weapons, tools, jewellery, personal artefacts and a few sorcerous artefacts.

State of Ruin: Buried, with a small town (Croton) built between some of the 'hills'.

Alien Nature: Miners report unexplained disappearances of crews and equipment.

Legend: In the modern town of Croton is a hidden temple that is so old as to make ancient Karutonia seem a recent upstart; the temple stood there when the land was a desert and it stood there when Aquilonia was an inland sea; it was old before Atlantis was born. The temple is reputed to be larger on the inside than its outside dimensions allow for.

Guardian: An ancient sorcerer, who may occasionally sell drugs or alchemy, lives in the temple, waiting for the return of the Old Ones.

PYRROPHLAGALON (RUIN)

Pyrrophlagalon was known as the City of Burning Souls, an Acheronian city. Its location is not known, but scholars predict it will be found near the Shirki River.

Cultural Type: Acheronian.

Historical Nature: The city was founded upon broken Valusian ruins. It was the home of Ixion the Devourer and the birthplace of his sons, Xaltotun and Dhurkhan. Pyrrophlagalon fell when the Hyborians sacked Acheron as a whole;

Physical Nature: Pyrrophlagalon was razed upon its fall, so little of its ruins will be left. There is always the possibility the Hyborians built an Aquilonian city or castle on top of the razed Acheronian city.

State of Ruin: Razed and buried.

Legend: The tomb of Ixion the Devourer has never been located and is believed to have been in Pyrrophlagalon. The tomb is believed to house horrible but wondrous artefacts of great sorcery.

ARGOS

Argos is one of the Hyborian kingdoms that rose out of the ashes of Acheron when it fell three thousand years ago. Situated on a coast line with natural sea-ports, unlike Shem, the people of Argos have become master sailors, crafty pirates and powerful merchants.

Houses in Argossean cities and towns are laid out in streets with sewage lines located under the roads to avoid disease epidemics. The Argosseans also reticulate water by means of underground water pipes and pressure boxes, although some areas continue to use aqueducts. They also possessed a form of underfloor heating for the winter months. Pillars and arches are a common sight in Argossean houses and public buildings.

Upper class Argossean houses have a wide central courtyard entered from a type of 'harbour', as they call it, or an atrium. Rooms lead off from the central courtyard. The houses are typically a single storey and use stone for the foundation, with frames of wood and clay plastering to build up the walls. The ceilings are eaved and most walls are frescoed with geometric patterns. Interior walls usually have painted scenes on them.

Most Argossean cities are divided into wards or districts to make the city more manageable.

Like Aquilonia, one might find Acheronian ruins or – as an extreme possibility – some Valusian artefacts. Most Argossean ruins will be of Hyborian origin, however. Abandoned castles, destroyed cities and historical monuments are the most common ruins found in Argos.

Historical Elements: Argos was founded when Acheron fell. Messantia was built on the ruins of Tartarus. About 1,400 years after the fall of Acheron, Argos was invaded by Stygia. The black sorceries of the Stygians wreaked a horrible storm across all the harbours. Up the rivers the Stygians came, bringing with them death, destruction and pestilence. Temples of Set were founded along the rivers as the Stygians conquered. The people began to abandon Anu, Bori and the other Hyborian gods as worthless once the power of Set was seen as



unstoppable. Fortunately for Argos and the whole of the Hyborian world a prophet arose in Aquilonia – Epemitreus the Sage. This prophet came bearing a message from Mitra, with counterspells and with power. The Stygians were driven from the lands, forced back to the sea and slaughtered. The power of Epemitreus and his god, Mitra, were embraced by the Argosseans.

List of Kings & Queens: Danaus (approx. 2,800 years ago); approximately 48 unnamed kings and queens (covering the 15 centuries between Danaus and Arcturus); Arcturus (approx. 1,300 years ago); Cassius; approximately 32 unnamed kings and queens (covering the 10 centuries between Cassius and Menetus); Menetus (approx. 380 years ago); Gellius (approx. 350 years ago); Isabella (Queen) (approx. 330 years ago); Darina (Queen); Demetrius; Prius; Penellia (Queen); Calemos; Miklus (start and end of the Blackblood plague (200 years ago)); Tirijs; approximately nine unnamed kings and queens (covering the century or so between Tirijs and Oderigo); Oderigo; Arrigo; Lucius; Costans (reigned until Conan's 17th or 18th

year); Tahrend (reigned for three years until Conan's 21st year); Wrenna (Queen) (short reign (a matter of months)); Milo (sometime before *Black Colossus* until the *Black Sphinx of Nebthu*); Ariostro (after the events of *Black Sphinx of Nebthu*).

EIDORAN (RUIN)

Eidoran is a ruin on a plateau in the mountains of eastern Argos. The mountains surround the plateau, which is cut off from the mountains by an immensely deep, round crevice.

Cultural Type: Stygian.

Historical Nature: During Stygia's reign over the lands of Argos, the city was built as a location where sorcerers could learn and summon demons from Hell. The first followers of Mitra bound the demons in stone and laid waste to the city.

State of Ruin: The demons litter the city like statues of pink stone. Pink columns and white and pink marble temples cover the plateau.

Legend: A crystal skull with a red ruby in its forehead can be used to awaken the petrified demons.

Guardian/Monster: The followers of Mitra guard the ruins so that sorcerers cannot arrive here and unbind the demons.

TARTARUS (RUIN)

Tartarus is possibly the first city built of Acheron. It did not achieve the size of many of the later Acheronian centres but it was an important trading centre for Acheron nonetheless.

Cultural Type: Acheronian

Historical Nature: The Giant-Kings fled Stygia, excepting those traitors who aided the Khari. Expanding outward, those early tall, white-skinned merchants built a trading outpost named Tartarus on the mouth of the Khorotas river. The army of Aquilon joined with the army of Koth and destroyed Tartarus. The purple-towered city was razed to the ground, forming the foundation for the Hyborian city of Messantia

State of Ruin: Razed and buried beneath Messantia

Legend: If one goes deep enough into the sewers (or, in some versions of the tale, underneath the harbours), underground passages lead to three ruined Acheronian houses and/or temples.

BORDER KINGDOM

This haunted land is another Hyborian nation, a buffer between the wealthy Hyborian territories of the south and the barbaric hordes of Cimmeria and Nordheim to the north. This savage land has no pirates, but thieves and temptresses can be found throughout.

Empty castles, manor houses and abandoned villages dot the border kingdom landscape. Life in a world fraught with bandits, sub-humanoids and stark living conditions takes its toll on would-be inhabitants, and the remnants of attempts to settle this haunted wilderness are found high on the hills and deep in the valleys throughout.

BRYTHUNIA

Brythunia is a pastoral kingdom of callused herders, sun-bronzed farmers and wilderness-wise hunters. Vineyards and orchards are plentiful and the kings of the city-states prosper. Most are blonde or tawny-haired. The nation looks small but according to the scale of the map in *Conan the Roleplaying Game*, Brythunia is about 258,000 square miles of land (which makes it almost twice the size of Poland).

Brythunia features Neolithic flint mines in the mountains and about 70 ruined castles from various eras. Ruined mitraeums and manor houses can also be found.

Historical Elements: Brythunia was the corridor between Acheron and Zamora through which the Hyborians filtered down from the north.

CIMMERIA

Cimmeria is a gloomy land and its people are depressed and sombre to an unhealthy degree. Conan was an exception,

which is why he fled the land, desperately seeking an escape, diving into a life of violence in the hopes of finding something worth living for. Cimmeria is a brooding land whose black memories drive Conan to drink himself to forgetfulness.

Cimmerian villages are not made of materials permanent enough to last long, so an abandoned village is only evident for a few years at best. Hearths and cooking pits last longer, however. The only notable ruin in Cimmeria is the dead outpost of Venarium – and little enough of it remains.

Historical Elements: Conan was born in Cimmeria. Aquilonia attempted to colonise Cimmeria and the Cimmerians fought back, destroying Venarium in a blood-thirsty battle.

CORINTHIA

Corinthia is a triangle of land south of Brythunia, west of Zamora, east of Ophir and north of Koth. Its landscape is mostly dominated by the Karpash mountains, which run along its south-eastern, southern and south-western borders. A portion of the southern 'point' of Corinthia is desert where the city-states of Kamalla and Zahmahn are located. The west is dominated by forests that rise on jagged mountainous ridges until the Karpash Mountains rise above the tree-line, separating Corinthia from Ophir. Ruins include trading fortresses built in Acheronian or Zhemri style, as well as early Hyborian styles.

Historical Elements: Corinthia, before the arrival of the Hyborians, was once the trade corridor between Acheron and Zamora. Corinthia was a kingdom during the time of Acheron and, although initially independent, later became a subject realm to that dark nation of necromancers and sorcerers. It became independent again 3,000 years ago when Acheron fell.

LANJAU (RUIN)

Lanjau, the city of the ages, is an ancient city that is now in ruins. It lies near the city of Atilleos but is located on no map.

Cultural Type: Trading (possibly Hyborian)

Historical Nature: The city is said to predate Crom and Mitra.

Physical Nature: The ruin is walled and columns were used in much of its construction. Gargoyles sit on several of its fountains. In the centre of the ruin is a temple carved out of a single block of stone. A circular motif with eight rays extending from the centre dominates the dual doors into the ancient temple.

State of Ruin: An earthquake, along with spouts of flame, devastated much of the ruin, leaving it crumbled and in poor

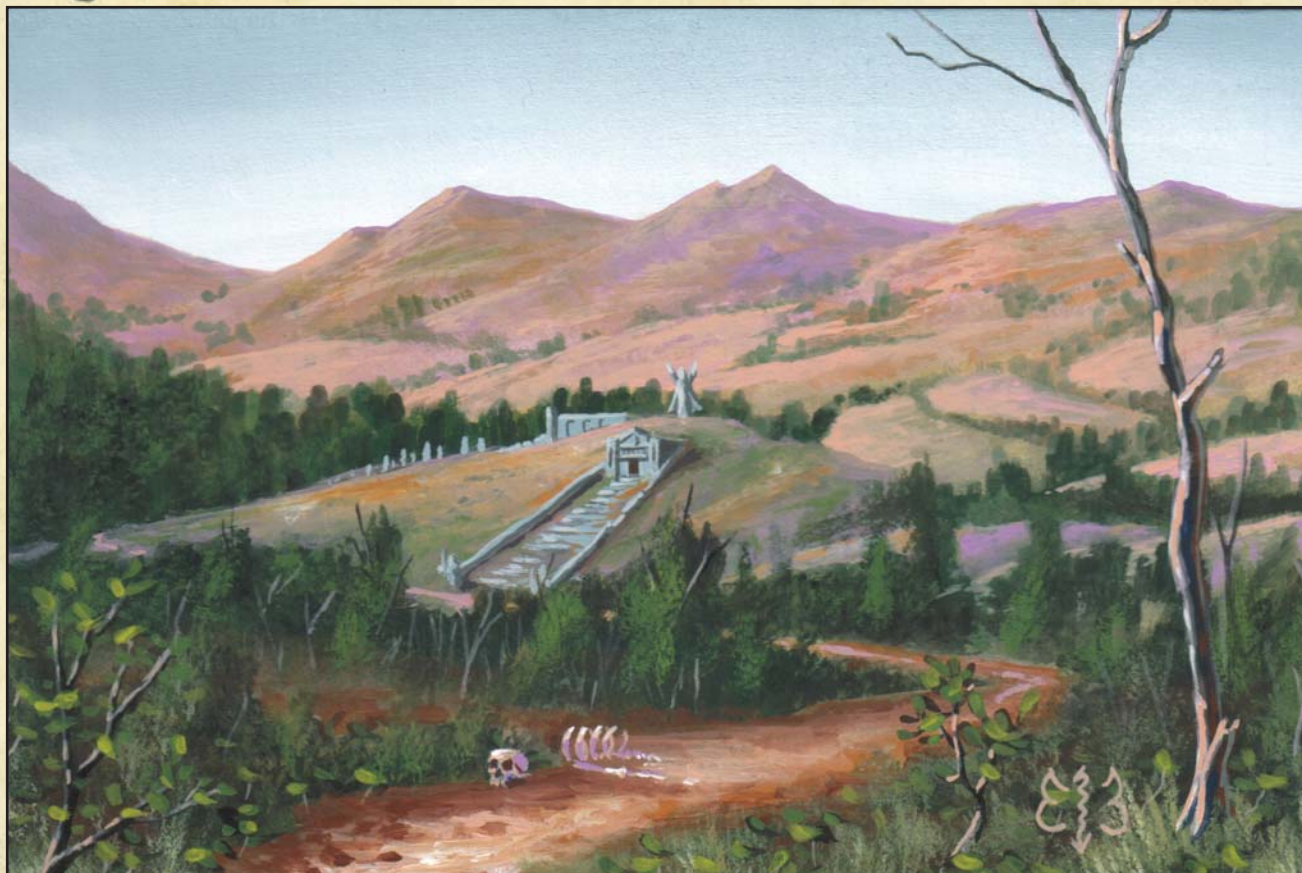

condition. Inner doors are often rotten enough to kick down easily.

Legend: Lanjau was the richest of ancient cities and the gods drove its inhabitants mad out of envy. A great treasure horde, enough to buy off every thief in Zamora, lies within but is guarded by the undead; a jade snake brought from this ruin came to life and killed a magistrate of Atilleos. The jade statue was later returned to Lanjau.

Guardian/Monster: The treasure is rumoured to be guarded by six giant mummies; the mummies are nigh indestructible but they will disintegrate if exposed to direct sunlight.

LONIKA (RUIN)

This is a city-state of the fertile meadowlands in central Corinthia. It lies southwest of Polopponi.

Cultural Type: Trading (Corinthian).

Historical Nature: Lonika was founded along a trading route beneath the ruins of an Acheronian castle (which was completely rebuilt). Lonika warred with Athros and Polopponi for years, although rarely did it escalate into a major armed conflict – mostly the wars were trading wars. Lonika was enslaved by the Lanjauans but won their freedom a generation later and returned home to find the Antilleosians in their city. The people merged. Later, the Lonikans made peace with the Polopponis by

making hostage trades with royal children. Lonika became a ruin after it was razed by King Zhenkri of Athros.

State of Ruin: The city was razed and there is little of it remaining – mostly just piles of rubble. It is badly crumbled and dangerous.

USKUTH HILL (RUIN)

In the northern hills of Corinthia, Uskuth Hill rises darkly, a mist-shrouded, forested monument of ill-repute.

Cultural Type: Unknown (Tomb).

Historical Nature: Centuries before the Cimmerians evolved from their primitive ape-like state, a fervent student of the dark arts ruled the men of the world, a student named Ingus-Kutha. He delved deep into forbidden lore, conjuring demons and trafficking with powers from beyond. He took the souls of men and of their virgin daughters to fuel his foul magic. In time, the fathers and brothers of his victims had enough and stormed Ingus-Kutha's stronghold, taking him by surprise. They slew him and buried him deep, walled in with stone. They put protective wards on the tomb, but the great cataclysm broke the crypt open. Although the sorcerer was dead, he had died with a spell half-formed on his lips, and when the crypt broke open, the half-formed spell called forth the demons upon the hill. The demons are bound to the corpse, trying to gather souls to resurrect the sorcerer.

Legend: Any who venture up the hill by dark never return

Monsters/Guardians: The hill is haunted by demons who fight among themselves each moonlit night atop the hill. The clashes can be heard at the nearby town. The demons are immune to physical damage, but the weapons of Ingus-Kutha can hurt them.

GHULISTAN

Himelian ruins tend to be Vendhyan or Oriental in nature; many of these are monasteries or scholarly retreats. Stupas and cairns are also common. Some Ghulistani build shelters out of rocks and these shelters may survive for a long time. Many ruins are buried beneath avalanches. The most common danger, aside from those derived from nature and the landscape, are the tribes and clans of tall, hairy hillmen, both strong and fierce. These hill tribes have their own barbaric code of honour, disdaining civilised behaviours, making fun of the weak and foolish. Above all, they hate traitors. Like the Hyrkansians, they prize horses and like the Vendhyans they prize customs and traditions. Like both, they fear mesmerism and sorcery. They are a fatalistic, superstitious lot, but easily enthused, especially at the prospect of slaughter and loot. They are of the east, and bound by long traditions and ancient ideas.

MOUNT YIMSHA

Mount Yimsha is the home of the Black Seers, practitioners of the worst sorts of black magic who seldom interfere in the lives of mortal men. The mountain home of the sorcerers is in an uninhabited region of the Himelians to the northwest of the hillmen's territories. The top of Yimsha is permanently snow-encrusted. Yimsha's slopes are too treacherous for horses, and no paths allowing for steeds exist.

Cultural Nature: Religious/Scholarly

Physical Nature: Near the snow-line, just above it, is the greater keep, a fantastic castle built by magic on the icy slopes, cut from the very stone of the mountain. Below that is a stone tower, the lesser keep, where the acolytes of the Black Seers, minor sorcerers, keep watch and practice their sorceries. A great chasm exists between the two keeps, a four hundred foot wide, five hundred foot deep chasm of death, filled with a deadly gas which can only be safely traversed by following a difficult to see thread of gold ore highlighting a safe path. This chasm encircles the mountain completely. Beyond that chasm is a broad stair cut out of a green, jade-like substance.

State of Ruin: Intact

Legend: The hillmen fear the Seers and avoid the mountain, considering it cursed and unholy, and will not build their villages near it or even within sight of it. When the Black Seers travel, they move as a crimson cloud or tornado effect enfolds them, creating the effect known as 'Yimsha's Carpet', which sends witnessing hillmen running for cover.

Inhabitants: The Black Seers

THE FORBIDDEN CITY

The Kirghiz of Mount Raktavashi live in a ruined stronghold known as the Forbidden City. The Kirghiz worship Raktavashi, the son of Erlik, Chief of the Seven Princes of Death. The stronghold itself is divided into castes, and the ruling castes are the shaven-headed, Khitan-featured monks who commune with infernal spirits, contemplate black mysteries of the hidden cosmos and read vile tomes of arcana. Kirghiz guards are huge brutes with shaven pates, but for a long top-knot.

Cultural Nature: Religious originally, now the ruin's economy is based on herding and has a small bazaar where fruits brought in from other lands are bought and sold.

Physical Nature: Small remnant of larger ruin destroyed by landslide.

State of Ruin: Mostly restored with a buried section.

Legend: Legends say the stronghold was reared by a demon-worshipping cult driven from a far-off homeland.

Inhabitants: The Kirghiz

Monster/Guardian: Horrible ghouls, the servants of Raktavashi, haunt the lower slopes of this bleak mountain, repeating, parrot-like, the last words of their victims.

HYPERBOREA

Hyperborea is a cold, windy land to the east of Asgard. Hyperboreans are often tall and gaunt with pale eyes and hair, although many have foreign blood in them. These people hunt wild animals, herd domesticated animals, gather meagre berries and pick pale mushrooms to supplement their sparse gardens of grains and vegetables. Their culture is inclusive, shunning most outside trade contact, so the Hyperboreans have minimal industry. Still, the Hyperboreans are skilled at woodcraft and stonework. Common Hyperboreans know how to move through the pine forests and survive in the wild for days. Many Hyperboreans go on extended wilderness forays, even going so far as to visit other countries.

There are approximately 60 ruined castles squatting throughout Hyperborea, perched on high hills, precipices or far within forbidding forests. Most of these ancient and broken castles are made of megaliths. Other ruins include cairns, ancient temples, strange megalithic circles and great statues from an unknown age. Which are often broken. Low fences of piled rocks can be found throughout the land. Grain bins made of piled rock or megaliths can also be found.

Historical Elements: Hyperborea is the first Hyborian nation. Hyperborea is also the site of the first Hyborian castle. They built castles throughout the land and there are possibly as many as 160 or more castles still extant in Hyperborea, although around 60 of them have fallen into ruin.



HYRKANIA

Hyrkanians are nomadic horsemen, cruel and ruthless, whose violent rampages across the steppe are still spoken of in frightened voices, as if the brutal conquests had happened but yesterday and not years or decades or centuries before. The area called Hyrkania lies to the east of the Vilayet and ranges from tundra to taiga forest to steppe to prairie and even desert. The Hyrkanians conquer all that they see, swarming over the terrain in overwhelming numbers on fleet horses.

Hyrkanians mostly build temporary villages and camps, as suits their nomadic nature. Some camps and villages, however, have become fairly permanent, especially along the trade routes. Hyrkanians often raze these cities and towns on a regular basis unless tribute is paid. Most ruins in Hyrkania are cities built by other peoples destroyed and assimilated by the Hyrkanians as they swept out of the east toward the Vilayet.

The sites of Hyrkanian worship are cairns of stones with a single vertical pole sticking out of the centre where prayers and sacrifice were performed.

Historical Elements: Hyrkanians are descended from the Lemurians and some tribes may maintain

ancient Lemurian artefacts as holy relics or heirlooms. Aboriginal peoples were conquered by the Hyrkanians and may have left ruins. Hyrkanians, especially Turanians, began to build cities late in their history. Most true Hyrkanian cities lie along the Vilayet or on the trade arteries between Turan, Vendhya and Khitai. Games Masters can have a free hand in creating ancient cultures and ruins in Hyrkania based on these unknown and lost cultures.

MAKKALET (RUIN)

Makkalet was once the chief trading rival of Aghrapur. Makkalet lied on the eastern shore of the Vilayet across from the Isle of Iron Statues. The city defended itself primarily by flaming arrows and flaming ammunition flung from massive siege engines.

Cultural Nature: Trading (Hyrkanian).

Historical Nature: Makkalet was one of the richest cities of the east. The city was governed by King Eannatum and Queen Melissandra. Its famed serpent walls had repelled Khitan hordes and Vendhyan raiders, but fell, in the end, to the ravaging Hyrkanian troops of Turan led by Prince Yezdigerd.

Physical Nature: A beautiful, brooding temple to Tarim was once here, carved and immense. Even the steps of the main wharf of the city was crafted from marble.

State of Ruin: Razed and burned. Some of the marble has been stolen but most of the buildings are still standing, although the wooden interiors were burned away.

Legend: Queen Melissandra survived the siege, bearing a child of Eannatum's. Perhaps her child will return and rebuild this once impressive city that glittered on the shores of the Vilayet like a jewel in the sun.

RAZADAN (RUIN)

Razadan was the twin of Dimmorz, another city besieged by Yezdigerd.

Historical Nature: Razadan was burnt to the ground by Yezdigerd during his wars of conquest for his father Yildiz.

State of Ruin: Burned to the ground. Some walls and sturdier features remain.

Legend: Shaven-headed Hyrkanians worshipped a stone idol in this region. The body was kept at Razadan, the head at Dimmorz. Together the head and body made for a powerful living statue if commanded by one who holds a certain amulet. Amulet, head and body are now somewhere in Aghrapur.

IRANISTAN

The culture of Iranistan is one of art, family, honour, hospitality and fatalism. Its people are barbaric and nomadic. Most Iranistani are familiar with horses and camels from an early age, using them for travel and food.

Early Iranistani cities were built on a circular plan, with the main streets radiating outward from a central plaza or building. Early palaces were oblong in shape with exquisite proportions. These early palaces were constructed in contrasting colours between varying designs and wall decorations. Later palaces were less colourful, but gave the appearance of being heavier, and had more ornate embellishments. The usual plan of these palaces was a central hall with columns surrounded by smaller rooms. Later still, the buildings of Iranistan became even heavier in appearance, even more ornate and the use of bright and contrasting colours returned. Frescoes and mosaics become common during this period. The central hall became a domed square surrounded by ornate minarets and *iwans* (vaulted areas with walls on three sides and a completely open (usually to a courtyard) fourth side. All periods feature large domes, arabesques, symmetry, ablution fountains and a focus on interior spaces. The culture prizes symmetry, so virtually all buildings are highly symmetrical.

Buildings were built of stone and ruins are found throughout Iranistan. Fire-temples, caravansaries, koochehs, baths, river bridges and tombs are common. Many buildings are octagonal in shape. Most Iranistani tombs found in the ruins are either domed mausoleums or tomb towers. The domed mausoleum is usually octagonal rising through various squinches and galleries to a circular dome on top.

YANAIDAR (RUIN)

Yanaidar, the city of the demons, lies in a deep canyon called the Gorge of Ghosts far in Drujistan. The ancient, demonic ruin is built on the southern end of an oval plateau against a dark mountain.

Cultural Nature: Unknown

Historical Nature: Thousands of years ago, the city was built by the ghoul-king Ura.

Physical Nature: Glittering Yanaidar appears larger than it is. Its domes, towers and flat-topped houses are compact, with two- and three-storey buildings, as well as gardens and groves. The city is dominated by a large sinister edifice with a purple dome shot with gold.

Defences: A parapet around the plateau provides the defence, as well as the wall around the actual city.

Legend: A thousand years ago an Ilbarsi chief settled in the ruins and began to restore them to make a stronghold for himself but one night he and his followers vanished. Another legend relates how the Sons of Yezm, the Hidden Ones, used this ruin for a base of operations.

Monster/Guardian: The Haunter of the Gulches (a larger than normal grey-ape, a snow ape of Pathenia); The Ghouls of Yanaidar live in chambers beneath Yanaidar and issue forth occasionally when it becomes obvious to them someone has taken up residence.

KHITAI

Khitai is described as being tangled amid thick jungles. Ancient temples hide within these dense wildernesses. Most Khitan ruins are temples that have been swallowed by the jungles and forgotten. Almost all Khitan ruins have a demon within them, a demon bound to the location in order to teach sorcerous skills and spells to those who dare to command them for such knowledge.

The defining characteristic of Khitan ruins is size. Khitans build everything with an eye to impress. Everything is built larger than life and with a grandeur the Hyborians can barely hope to match. If a palace in Khitai has a moat, it is a huge moat, spanning hundreds of feet in width. If a palace has a tower, the tower is built taller than a comparable tower in Aquilonia. If the Khitans decide they want a wall, they build a wall to put all other walls to shame.

Khitan ruins often include musical instruments, especially chimes and bells. Drums, zithers, panpipes, mouth organs and flutes are also common. Terre cotta soldiers and horses are sometimes buried with kings in tombs. Typical constructions include pagodas (tiered towers), an emphasis on width rather than height, an emphasis on symmetry and curved roofs. Roofs are more important than walls in Khitai. Colours are important in Khitai; only temples use blue roof tiles and only

the Emperor may use yellow tiles. Although the architects in some eras built in red brick or a coloured stone, most construction is wooden, so many ruins deteriorate quickly. Important official buildings or gates are quickly identified by the stone Imperial Guardian Lions, which appear in pairs. The male lion protects the building and the female lion protects the inhabitants.

Historical Elements: Yogah of Yag, also called Yag-kosha, lived among the ancient Khitans. Beyond this, the history of Khitai is unknown in the West.

KOTH

Koth is one of the oldest Hyborian kingdoms, a vast meadowland north of Shem, founded alongside Corinthia and Ophir. Ruled by warring princes and barons, the Kothian culture is a strange brew of Shemite, Stygian, Acheronian and Hyborian ideas and ways. Currently, Koth is vassal to Aquilonia.

Kothic ruins generally resemble Hittite ruins. Also, because Koth was originally part of Stygia, there are Stygian ruins throughout Koth, as well as Stygian features in current Kothic cities. There are also Acheronian ruins to be found. Many current Kothic cities have ruins within them; for example, Khorshemish holds the ruins of the Scarlet Citadel inside its walls. Indeed, Khorshemish is built on top of Acheronian ruins and earlier versions of Hyborian ruins. There are about a hundred abandoned castles throughout the countryside of Koth.

Their architectural style includes entrance halls with porticos approached by a stairway flanked by pillars. Kothians also make use of double gateways with corbelled arches. They decorate these gateways with friezes and gargoyle-like monster statues on either side. Domestic homes are built as large halls with a central hearth and four columns to support the roof.

The natural circumstances of Koth dictated how buildings were designed. The Kothians were the first to use half-stone/half-timber construction methods. Koth is a fertile land with plenty of rain, so the foundations of Kothic buildings are of stone. Earthquakes are also common in Koth, so a timber framework is used to give the buildings the strength to withstand most of the trembling. Mud brick or rubble is used to fill in the upper timber framework. Almost all Kothic architecture is rectilinear.

Historical Elements: Koth was originally part of Stygia but they allowed the Hyborians to settle the land as a vassal state. After Stygia was pushed back and Kuthchemes sacked, Koth became the overlords of the land of Shem. Koth

then fell prey to Acheron and became a vassal state to the black empire.

EL-SHAH-MADDOC (RUIN)

El-Shah-Maddoc is a smoking ruin of a city blasted apart by magic.

Cultural Nature: Trading (Kothic)

Historical Nature: El-Shah-Maddoc was a walled city in Koth with a population of 12,300 people. It was built in the meadows regions and eventually conquered by King Irham of Syreb who wanted to control the trade in the region. It was later utterly destroyed in a magical blast.

Physical Nature: It is a fairly large ruin but is almost unrecognisable as a former city – it has been reduced to rubble.

State of Ruin: Blasted apart; there is a central crater and all the buildings are knocked down in a scatter pattern radiating outward from that blackened crater. Nothing is left standing.

KUSH AND THE BLACK KINGDOMS

The so-called Black Kingdoms of the Hyborian Age are a grouping of widely disparate groups of indigenous peoples, each with their own habits, religions and lifestyles. The differences from one group to the next vary more expansively than can be discussed fairly in a work of this size. With the broadest of strokes, some of the more well known tribes and kingdoms will be discussed below. The Games Master is encouraged to do his own research into real-life or fantasy Africa to give a more realistic flavour to games run in these jungle-shrouded kingdoms where violence is taken as a daily matter of course.

Ruins in the Black Kingdoms can be of almost any type. Atlantean ruins, green-stone city ruins, tribal ruins, elephants' graveyards, stone ruins, pyramids and tombs are all possibilities. Styles differ greatly from one kingdom to the next; for example, Zembabwei forgoes rectilinear forms in favour of curves and circles. Some use megalithic architecture, others use mud, thatch, wood, bone or other local materials.

ALKMEENON (RUIN)

Alkmeenon is the ruined city lost along the south western jungle fringes of the near-mythical realm of Keshan. The ruins are now considered to be holy ground to the priests of Keshan and the surrounding jungles are taboo.

Cultural Nature: Unknown (Religious)



Historical Nature: Alkmeenon was said to have been founded by the great and wise ancestors of the current ruling class in Keshan. According to local legend it was here that a mysterious white race of men founded the civilisation of Keshan more than 1,000 years ago. Learned and civilised far beyond the primitive Kushite tribes around them, these people wielded their superior power to impose their will on all. They took what they wanted, amassing great wealth in the form of gold, jewels and slaves. In time, the people of Alkmeenon set themselves up as masters of the region, ruling over all the tribes and reaping the rewards. Princess Yelaya was the last ruler of Alkmeenon and, when she died, her youthful and beautiful body did not decay. Her spirit is the supposed oracle. Priests of old went to her to learn wisdom, but the custom has died off since one priest tried to steal the Teeth of Gwahlur (see below) and a doom came upon him. The priest Gorulga reinstated the tradition during Conan's lifetime.

Physical Nature: The ruin is located in the south-western corner of the kingdom amid uninhabited jungle. The royal palace of Alkmeenon is surrounded by great cliffs, a vast natural amphitheatre three or four miles in diameter, with a couple of secret passes that only the priests of Keshia know. Under the surface of the water is a cave mouth that enters the inner city of Alkmeenon. The city itself lay outside the cliffs, swallowed by the jungle. Jungle has also claimed the inner palaces and lotus trees grow among the south wall of the

cliffs near the avenue that leads to the palace. An unhealthy underground river of frigid, black water passes beneath the palace.

State of Ruin: Overgrown but largely intact.

Legends: The ruins house the legendary treasure known as the Teeth of Gwahlur; they are said to be the wealth of an epoch, and, according to Conan, fell into a darksome and cold river beneath the ruin. The Oracle of Alkmeenon, Princess Yelaya, is said to make pronouncements and divinations here.

Monsters/Guardians: The near-immortal, cannibal servants of Bit-Yakin lurk within the ruins. These grey-haired monstrosities are grey devils (see *Conan The Scrolls of Skelos*).

CITY OF THE WINGED ONE (RUIN)

The City of the Winged One is reached by travelling the poisoned waters of the Zarkheba River, a broad and sullen river along the Black Coast. The City of the Winged One is covered in detail on page 49.

GAZAL (RUIN)

Gazal is an ancient city of jade-green spires and minarets built amidst the



palms of an oasis. Gazal is covered in complete detail on page 70.

XUCHOTL (RUIN)

Xuchotl is an ancient oval-shaped city located to the south, in the jungles that infest the lands of Darfar and beyond. Xuchotl is covered in detail on page 109.

XUTHAL (RUIN)

Xuthal is a green-stone city gleaming on the grasslands of Kush. Unlike every other such site, Xuthal still stands and is occupied by descendants of the ancients who must have raised these fantastic structures.

Cultural Nature: Green-Stone Culture

Historical Nature: Unknown

Physical Nature: It is built upon an oasis. The city walls are built of a greenish stone that shines like glass. The walls are thirty feet high and the parapets and minarets are much higher. The city is designed as one great palace, with each building inside the walls and interconnected. The houses are lofty and made of the same material as the walls. The homes are decorated with velvet tapestries and the interior walls, floors and ceilings are constructed from the same green stones. Glowing jewels light many of the chambers. The jewels are charged with radium and glow when touched. Gold friezes decorate the walls in curious designs, furs and satin cushions litter the floors, tables are made of polished ebony and goblets made of jade and utensils of gold abound.

State of Ruin: Intact and inhabited

Inhabitants: The city is populated with a yellow race with slightly slanted eyes, but otherwise Hyborian in type. They dress in silk tunics and high-strapped sandals, arming themselves with short swords. They speak Stygian as well as an unknown tongue. They are lotus-eaters, living in a drug induced dreamland, visiting impossible realms such as Andarra, Tothra and Kuth of the Star-Girdle. The city is fairly well populated, but most times the inhabitants are slumbering, visiting their dreamlands. When not in their dreams, they are among the foremost scientists of the age. They create a golden elixir that heals wounds.

Monster/Guardian: The people of Xuthal worship Thog the Ancient, who sleeps beneath the city. When Thog grows hungry, he stalks the dark corridors of Xuthal and eats a few of the inhabitants. Although Conan fought Thog, it is likely the ancient god still lives and still stalks the haunted corridors of Xuthal where the lotus-eaters still dream.

NEMEDIA

Nemedia is the second great kingdom of the Hyborians, technologically and economically superior to the other Hyborian nations save Aquilonia. Nemedia's culture is similar to Aquilonia's, although

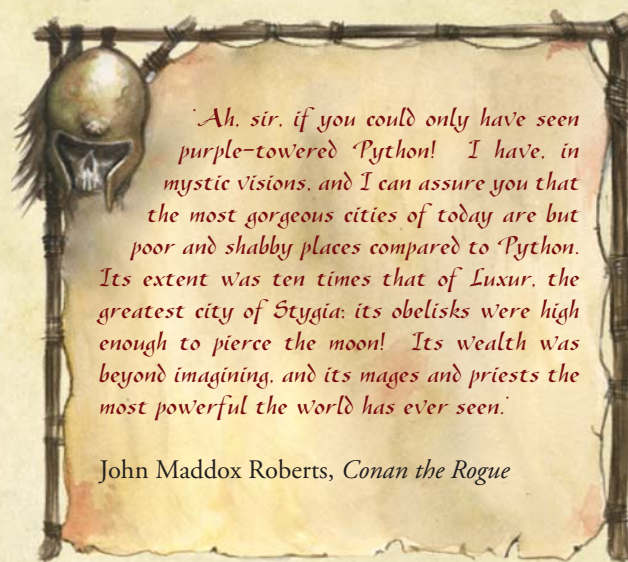

'Ah, sir, if you could only have seen purple-towered Python! I have, in mystic visions, and I can assure you that the most gorgeous cities of today are but poor and shabby places compared to Python. Its extent was ten times that of Luxur, the greatest city of Stygia; its obelisks were high enough to pierce the moon! Its wealth was beyond imagining, and its mages and priests the most powerful the world has ever seen.'

John Maddox Roberts, *Conan the Rogue*

the Nemedians emphasise feudal bonds more and personal freedoms less. Still, Nemedias is well regarded for scholastic and intellectual freedom, for the greatest historians, the most famous philosophers and the pinnacle of powerful orators in the West are Nemedians. Nemedias is an ancient kingdom, proud of its cultured sophistication and civilised traditions.

Nemedia is the scene of much history, for ancient Acheron once existed over much of Nemedias. Ruins of Acheron certainly exist, hidden away in hills and nestled in secret places. Some of the ancient homes of the Acheronians were so devastated by the Hyborian barbarians that today the ruins may resemble little more than mounds or hills and someone digging to unearth some buried treasure may unleash untold horrors upon an unsuspecting populace.

Built on the ruins of ancient Valusia and once a part of the sorcerous kingdom of Acheron, Nemedias has many hidden ruins that might contain fearful horrors.

Historical Elements: Although settled by the Hyborians, 3,000 years ago this was the land of Acheron and traces of Acheronian blood flows through many of the veins of Nemedian Hyborians. The hills of Nemedias still hold groups of people who boast of their Acheronian descent. 900 years ago, King Bragorus ruled Nemedias and invaded Aquilonia. King Tarascus took the throne of Nemedias when his father (King Nimed) and older brothers died in a sorcerous plague.

Known Nemedian Kings: Bragorus, Nimed, Tarascus

PYTHON (LOST RUIN)

Python is the ancient capital of Acheron. Python is a lost city; its treasures have lain unfound for 3,000 years. Its priests and sorcerers were the most powerful to ever walk the world.

Cultural Nature: Acheronian (decadent, scholarly capital)

Historical Nature: The last king of Python was Ahmas XXVII; he died fighting Hyborian barbarians in front of the Ruby Gate of Python's royal palace. Purple-towered Python was defended street by street when the Hyborians invaded.

Physical Nature: The ancient city was colourful, and the colour purple dominated. Its spires ascended unprecedented heights, beyond even the abilities of modern Stygians or Zamorians to duplicate. The city was unbelievably huge (one scholar claims it was ten times the size of Luxur) and built in a circular pattern. The architecture is notably alien, using, through magic, some non-Euclidean geometry. The ruins, should they be found, will be minimal as the city was probably razed.

State of Ruin: Unknown. The location has never been precisely determined. Believed by most to be in Nemedi, although some scholars argue for an Aquilonian location. Some modern Hyborian scholars believe that the City of the Purple Towers lies in north-eastern Nemedi, in the wilds near the Border Kingdom. It is likely the city has been razed and built over.

Legends: Before Python fell, King Ahmas XXVII sent the treasury, the wealth of Python, south on a fleet of dark ships. The fleet is a historical fact, but its cargo is speculation; the fleet was never seen or heard from again. Xaltotun lived in ancient Python, but fled as an exile to Khemi when his power was broken.

NORDHEIM

The Nordheimir are fierce warriors, proud and honourable. With white hot enthusiasm they pursue life, facing death fearlessly with a song on their lips. They are giant men who value honour, loyalty and reputation above all things, for their land is harsh. Even the women are strong, running households while the men war with each other across the icy plains and mountains. War is an essential ingredient in the life of the Æsir and Vanir.

This predilection for war has left behind many ruined villages. Fighting, plague and famine wipe out entire settlements. The frozen tundra often preserves the villages far longer than they would survive in a more humid climate, but still, the remains do not last long because they are mostly built from perishable materials, such as turf and wood. Nordheimir villages are encircled by earthworks, usually ditches and mounds. Most wealthy Nordheimir homes are longhouses with a fire pit or hearth in the centre. A poor man's house is three- or five-yards long and rectangular in shape. Grain storage buildings are built on stilts with a ladder to the door. The Nordheim also built saunas, workshops, barns and meat-drying sheds.

Artefacts are the most easily recovered item in Nordheim. Most artefacts are highly decorated, often with a dragon or bird-of-prey motif, as well as stylised patterns.

OPHIR

Ophir is a feudal kingdom, as many Hyborian kingdoms are. It is not as unified as Nemedi and is more fractious than Aquilonia. Ophir has a fragmented government ruled by an aristocratic class of local powers, counts and barons, who perform civil and military functions in the name of the king for an equally fragmented kingdom subdivided into numerous fiefs and sub-fiefs. The people of Ophir tend to be a silent, surly lot and do not trust outsiders. Its society is ruled by noble houses and they pride themselves on their scientific knowledge.

The economy of Ophir is based on mining gold ore and other mineral deposits, so many ruins revolve around lost mines and mining villages. Many mines become abandoned when parts of them cave in or dangerous gases fill them. Others are simply lost when the miners are slain due to cave-ins, bandits, monsters, etc. and no one knew where their mine was to begin with.

Ophir is also filled with feudal castles, many of which become ruined over the course of history. L. Sprague de Camp and Lin Carter's castle of Theringo in *The Star of Khorala* is an example. Other types of ruins include Mitraeums and Acheronian temples.

Historical Elements: Two hundred years ago, Count Alarkar tried to provide a stable government by forcing the nobles and the king to sign a charter; the attempt failed.

Known Kings of Ophir: Moranthes II (father of Olivia), Amalrus (during the events of *The Scarlet Citadel*), Ludovic.

THERINGO

Theringo is the name of an Ophirean county and castle. The castle and county are located southwest of Ianthe, near the Aquilonian border. Four towns still owe fealty to the count of Theringo, though there is no capital city any longer. It is surrounded by the towns of Thepahl, Ajon and Harjorj.

Cultural Nature: Warrior (Hyborian military)

Historical Nature: Built on a plain, it was the location of the Battle of the Hundred and One Swords 200 years ago. Queen Marala of Ophir came from this line of fief-holders. There is still a count of Theringo, although he does not live in his ancestral hall.

Physical Nature: Medium Castle

State of Ruin: Crumbled in the upper portions but the lower portions are mostly intact. The roofs of the various buildings are gone.

PICTLAND

The Pictish Wilderness is a lush forest, an expanse of dire swamps and thickly vegetated woodland, hilly and almost jungle-like in its vitality and fertility. Any major stone ruins found in Pictland usually date from pre-Cataclysmic times. Most Pictish remnants are artefacts, not features. The most well-known ruins found in the Pictish lands are the destroyed remnants of Aquilonian attempts at occupation, such as the settlements of Conajohara (which were destroyed during the events of *Beyond the Black River*).

Ruined Pictish villages are generally defended by terrain features, a palisade, earthworks or all three. Terrain features include building the village on high ground or an island surrounded by swamps. Rarely do the Picts build their villages against a major river bank, as attacks by animals (such as alligators) and enemies are much easier in such locations. Usually they build their villages a mile or two away from major waterways, using distance as a defence. The Picts further fortify their villages with wooden palisades. The larger villages will have more than one palisade, built in an almost maze-like fashion. These palisades are built of timbers lodged securely in the ground. The palisades vary from tribe to tribe in terms of shape and size, but are usually rectangular or oval, reaching up to twenty feet in height.

The Picts live in caves and tree shelters, as well as mud-and-wattle huts collected in villages. Other tribes build powerful villages of longhouses built of wood. Their homes are decorated with the grisly skulls of enemies. Depending on the size of the tribe, anywhere from 30 to 100 macabre bark longhouses or mud-and-wattle huts are held within the ramparts and palisades of a Pict village. Most Pictish constructions deteriorate quickly in the wilderness, although artefacts and some fire-hardened features can be found long after the more obvious signs of former occupation have decayed into the soil.

More information on the cultural trappings and building techniques of the Picts can be found in *Conan: Across the Thunder River*.

Known Chiefs and Warlords of the Pictish Wilderness: Dekanawatha rises to power among the Wolf clan sometime after *The Hour of the Dragon*. During or after the events of *Black Sphinx of Nebthu*, Dekanawatha falls in battle and is succeeded by Sagoyaga.

SHEM

Pastoral Shem is a non-Hyborian land of decadent despots in the west and fierce nomads to the east. Shem is a large nation, lying betwixt Koth and Stygia. To the west and to the east are Argos

and Turan, respectively. In the west, Shem is meadowland, in the east, desert. The most common ruins found in Shem are old Shemite cities or Shemite Zikkurats.

Shemite Cities

Shem is home to some 34 cities, 180 towns and over 19,000 villages or nomad encampments. Most of the cities and towns are in the west and tend to be the seats of power for each city-state, ruling attendant towns and villages. The cities are constantly at war with each other, even though few, if any, of them are economically stable enough to exist without the trade that passes between the cities, for each city has specialised in some tradable good or other, such as weaponry, wines or the herding of animals. Shemite cities are characterised by white zikkurats and gleaming towers. The only laws in these cities are the ones enforced by the individual kings. What is against the law in one city-state may well be perfectly legal in the next.

Shemite cities, often surrounded by high, wide, rectangular walls, are centred on a zikkurat dedicated to a god, for a god either owns the city or comes from the city. Smaller zikkurats may surround the largest one. Broad avenues lead from the city gates to the central zikkurat. The zikkurat is a terraced pyramid; the terraces are often planted with trees, shrubs and other plants, forming gardens. On the top of each zikkurat is a shrine to a god or goddess.

Near the central zikkurat the king and the nobles live in grand palaces complete with spacious gardens and open courtyards. The wealthy citizens have white-washed, two storey houses with around a dozen rooms and servant quarters. The buildings of the wealthy are white-washed inside and out to present affluence and an appearance of cleanliness. Some actually have mausoleums on the grounds.

The homes of the middle classes, still clustered tightly amid the web of thin alleys, are usually one storey with a central court amid several rooms.

The common people, slaves mostly, live in small mud-brick houses packed together as tightly as possible in a hodgepodge. Craftsmen who practice the same trade live and work on the same street. These streets are lined with shops and stalls for these craftsmen, serving as a type of bazaar for each particular type of good.

Many of the cities have canals to serve as harbours for boats. Each city also has one or more 'ports of trade,' called *karum*. The *karum* may be actual harbours, if the city has a riverfront or is on the sea, or the *karum* may be a harbour for caravans. In addition to being a centre of commerce, the *karums* also house foreign traders, keeping them segregated from the arrogant Sons of Shem.



Shemite Temples & Zikkurats

Lofty white zikkurats are reared to their gods, for to the Shemites, the gods are quite real, not just some illusion conjured by man's mind to explain the mysteries of the world. On top of the zikkurats are Shemite temples. The largest zikkurat, the true centre of the city-state, is the home of the city's patron god or goddess.

The zikkurat is a massive stepped pyramid holding aloft a rectangular temple. The zikkurats are not hollow and do not generally have rooms or passages. A new king often enlarges the main zikkurat by building on top of the previous one, creating a 'nested doll' effect. If one were to dig into a zikkurat, he would find a smaller one within, then another, then another. One end of the zikkurat has three staircases radiating out from the centre of the front wall. The three staircases converge at a tower gate, which then opens to a single staircase leading up to the temple. The sloping glazed-brick walls have weep holes to draw moisture from the core of mud-brick. All the straight-lines on the zikkurat are slightly convex to make the structure more aesthetically pleasing. Often the mud-brick deck floors are gardens.

A Shemite temple is a mud-brick building and has a rectangular central nave with aisles running along either side. Rooms for musicians, singers, priests and priestesses line the aisles. An altar for animal and vegetable sacrifices stand at one end of

the temple in front of a statue of the temple's deity. This great statue is the physical dwelling of the god or goddess. Great torches and sconces send dark shadows flickering and dancing across the entire nave. Daily are certain black rituals and gruesome sacrifices performed at this altar, some public, some not so public. Monthly feasts are also performed in this shadowed vestibule. Of course, the twice-annual sacred marriage by the king to the high priestess also takes place on the bloodstained altar, which is decorated and prepared as a bed for the occasion, which is a sexual ritual designed to link the god's magical essence to the people.

Just as the zikkurat represents a mountain to the Shemites as a home to the gods, there is also a representation of the sea in every temple and shrine. This representation of the sea, called the *apsu* basin, is an elaborately decorated stone basin found in Shemite temples to represent the beginning. Depending on the god or goddess of the temple or even the specific ritual being performed by the priests, this basin might be filled with water, molten metal, quicksilver or any number of exotic or mundane fluids.

The temple complex not only includes temple and zikkurats of varying sizes. Granaries, storehouses, estates of the high priests and priestesses and grand mansions are also part of the temple complex.



Historical Elements: According to John Maddox Roberts, a kingdom called Ashur once stood where Asgalun now stands. Ashur was a maritime nation for 300 years during the reign of the Den Dynasty. An earthquake brought down the walls of Ashur and raiding Shemites laid waste to the city, then built Asgalun upon Ashur's ruins. 300 years ago, Argos invaded Shem. A decadent, corrupted race led by King Skauraul ruled the lands now known as Shem for several hundred years ago, long before Acheron – before the Cimmerians were known as Cimmerians, but after the Great Cataclysm.

ABABENZZAR (RUIN)

Ababenzar is an ancient ruin now protected by Ishtar. The ruin is located in the far east of Shem, in areas now controlled by Turan in theory but by the nomads in fact.

Cultural Nature: Religious (actual culture unknown; city is devoted to Ishtar).

Historical Nature: It possibly dates back to Acheron or perhaps even the Thurian age. Some claim the city predates even the era of King Kull when he sat upon the throne of decadent Valusia.

Physical Nature: 50% Crumbled/50% Intact; the architecture is alien. Curious spires, leaning towers, fallen columns and curious designs create an uneasy feeling as people move through the ruin.

State of Ruin: The ruins are silent. Only half-crumbled towers and weirdly armoured mummified corpses remain to whisper darkly of the dead city's ancient glories. Bandits once used the ruins as a hideout but now it stands quiet and undisturbed.

Legends: The nomads speak of a curse put on the city by Ishtar herself, proclaiming that not a precious stone or other treasure will ever be allowed to leave the boundaries of the city again. There are jewels and gold aplenty to be found by visitors but death comes on swift wings to those who take it past the ruined city walls. The nomads avoid Ababenzar and consider it a haunted, evil place of black dooms and glittering, untouchable treasure.

Weird Element: Anyone who takes treasure from the city will suffer Unexplained Actions (see page 23) once per day until the treasure is returned.

Monsters/Guardians: Only desert snakes and scorpions live there now – although ghost stories abound about the ruins.

BÊCHARADUR (RUIN)

Bêcharadur was once a coastal city-state in the meadow region of Shem dedicated to Dagon. It once stood on a rare harbour along the Shemite shore.

Cultural Nature: Religious (Shemite)

Historical Nature: Originally built by the Ashur, it fell to the Shemites shortly after the Ashur capital fell. It was rebuilt as a Shemite city over two decades later

and dedicated to Dagon. It was destroyed by Imhotep the Ravager, a demon.

Physical Nature: Typical Shemite city (square design) until it was flattened.

State of Ruin: It is now a razed and flattened city. Even the zikkurat to Dagon was blasted into dust.

Legends: The Shemites, considering it a cursed location, have not rebuilt it, despite its position on a rare harbour.

Monster/Guardian: Pirates occasionally use the site to hide or rest.

BURYAT (RUIN)

Buryat is a city built low to the ground, hiding behind a sea of tall grasses. Dwarfish men lived in this city on the meadows of Shem south of Akkharia. The people of the city worshipped Nasati, the Heaven Bear.

Cultural Nature: Religious (dedicated to Nasati by a race of dwarfish men)

Historical Nature: The people who built Buryat were driven out by Conan and some Æsir warriors many years ago.

Physical Nature: Walled, but low to the ground. All the buildings are likewise low to the ground.

State of Ruin: Intact but beginning to decay. Buryat's ruins are maintained sporadically by groups of bandits, although they generally never effect a full repair.

Legends: A giant god-bear roams the region in some legends.

Monsters/Guardians: Bandits sometimes hide there.

KAETTA (RUIN)

Kaetta was a small semi-permanent Shemitish nomad village that inexplicably worshipped Mitra. The village specialised in opals and held less than a thousand people. It also possesses a great tunnel system of catacombs.

Cultural Nature: Artistic (Opals) and Religious (Mitraic).

Historical Nature: The sheikh of the nomad tribe dwelling here was named Lord Ranjau. The temple of Mitra in Kaetta was built upon the ruins of an ancient temple to Ibis.

Physical Nature: The village is situated around an oasis spring, although the water from the spring is not enough to irrigate crops. Located north of the Styx, it sits upon a plateau in the desert. The plateau is entered via a narrow, rock-walled passage that twists gradually upward. The passageway gradually widens and opens into a broad bowl-like circle around the spring. The converted temple is built at the centre of the bowl. The people live in cave dwellings around the wall, keeping to the nomad's traditional injunction against building homes.

State of Ruin: It is now a ruin, its population slain and its temple defiled.

Monsters/Guardians: Nomad tribes may now use it for its water.

KUTHCHEMES (RUIN)

Kuthchemes is a mysterious ruin in the far south-eastern deserts of Shem. Kuthchemes is covered in detail on page 86.

NITHIA (THE CITY OF BRASS) (RUIN)

Nithia, known as the City of Brass, is located about a day's journey on camel away from the ruins of Kaetta.

Cultural Nature: Religious (Ibis-worshippers, age of Acheron)

Historical Nature: Nithia was founded 4,900 years ago. Three times before it finally fell the city was assaulted by foreign armies. Eventually, the Nithians became so peaceful they were unable to defend themselves against the final assault by the Acheronians. The city was destroyed by the forces of Acheron, led by the Supreme Warlord of the Imperial Legions, the Jackal – also known as Dhurkhan Blackblade, the brother of Xaltotun. The city housed the legendary Seven Fountains of Ibis. The fall of Nithia brought about the virtual end of Ibis worship – only a few cults exist today.

Physical Nature: The city is built of white marble topped with brass spires and roofs. It is a round, walled city, capable of supporting 9,000 people. The streets run toward the centre of the city. In the centre stands the greatest marble temple of the known world, a temple with crystalline roofs and brass spires.

State of Ruin: Buried underneath tons of sand.

Legends: Rumours state that anyone dedicated to Set (has an Allegiance to Set or his temples) who enters Nithia will cause a calamity, both to themselves and certain artefacts within the city. Siptah writes that the worship of Ibis empowered the city to protect itself against Set and his allies. The statue known as the Grim Grey God is said to be harboured in these ruins, buried beneath centuries of sand.

Monsters/Guardians: The ruins of Nithia, protected by the countermagic of the long-dead cult of Ibis from having its location divined, is also protected by the Curse of Solnarus, which turns people into sand.

SKAURAUŁ'S STRONGHOLD (RUIN)

This is a greenish-black stone stronghold from antiquity located in the Shan-e-Sorkh desert.

Cultural Nature: Capital (Mutare, a corrupted human race with reptilian aspects).

Historical Nature: Built thousands of years ago (before the Cimmerians rose from their ape-like state to become Cimmerians) by the self-styled monarch of the Mutare, whose name was Skauraul, this stronghold was a breeding ground for obscenity and horror. Thousands of people

died there, impaled. He found the secret of immortality, so Skauraul lived for hundreds of years. Skauraul was eventually overthrown and impaled on a silver spike. The revolt was led by priests of Mitra in Shem.

Physical Nature: Walled. Monumental gates sag in ruins on broken hinges, leading to the actual stronghold. The stronghold was roughly circular, made of eleven greenish-black megaliths tapering toward the top, several hundred feet high. There were no windows. The single door was made of black iron. Weathered stone griffons stand guard along the worn steps to the single black door. Internal passageways do not generally have doors; instead, they have illusions of walls one can pass through. No torches, tapestries or decoration is used – just symmetrical brick-work. What doors are there are made of iron. However, the essence of Skauraul was defeated as he was trying to resurrect himself and the stronghold crumbled as if hit by a god's hammer.

State of Ruin: All is dust now, a complete and utter ruin.

Legends: There were reportedly hundreds of dark volumes with long-forgotten secrets of dark, sorcerous arts, the greatest store-house of arcane knowledge in the world. The esoteric Thurian Codex was rumoured to be among this sorcerous horde. Of course, all of that is gone if the site is encountered after Conan passed through it.

Weird Element: Element of Horror (see page 23) unless the character has 1 or more Corruption points.

Monsters/Guardians: Before it crumbled, the stronghold was protected by speaking Children of Zath (giant spiders) and the spirit of Skauraul.

TAL'IB (RUIN)

Tal'ib is also called the 'City in the Waste', and is nothing more than the haunted ruins of a long dead city named Yb. It lies in a southern gorge of the Mountains of Desperation to the west of Qjara.

Cultural Nature: Religious.

Historical Nature: Destroyed in a magical explosion.

Physical Nature: A carved obelisk sacred to Votanthe can be found there.

State of Ruin: Toppled. Across the dead flat of the gorge, shards and monoliths lie scattered. Hardly one stone remains on top of another.

Legends: It is said to be a reliable source of water in an otherwise waterless wasteland. However, strange tales of unspeakable horror surround the ruins.

Monsters/Guardians: The oasis is there amid the ruins but at night the ape-like descendants of the former inhabitants will attack. They are dressed in sheepskins.

STYGIA

Stygia is a decadent, sinister menace, a black land of nameless horror feared by the Hyborian races. Ruled by a dark theocracy devoted to the cult of Set,

its small population is notably xenophobic, and the people are obsessed with the subjects of death and immortality, building dark tombs and worshipping foul deities. The population of about four million people is notably small for a kingdom of its size, for there is little arable land for the people to live on and there is a constant demand for sacrifices by the cults. The Stygian cults utterly dominate Stygian society. This theocracy is conservative and closed-minded.

STYGIAN TEMPLES

The shadowed temples of dark Stygia are made according to proscribed rituals and architectural designs. They are usually huge structures, imposing and powerful, often made of black stone and have a menacing aura. To enter one without permission is cause for a Terror check (DC 18). The black temples are contained within a walled temple complex.

STYGIAN TOMBS

Stygian tombs are covered in detail on page 99.

Some of the ruins include Pteion the Damned (see page 93 for a detailed look at this particular ruin) and Khet (see page 83 for a detailed look at Khet).

Note: For more information on Stygia's history and kings see *Conan: Stygia – Serpent of the South*.

NEBTHU (RUIN)

Nebthu, the City of Tombs, is a ruined necropolis that looms over the Bakhr River.

Cultural Nature: Necropolis (Stygian).

Physical Nature: Nebthu is well known for the large stone hyena-sphinx that crouches outside the crumbled foundations that are all that remains of the ancient town walls. This sphinx is made of some smooth, lustrous black stone, like jet or basalt. Its head is of some beast of prey with a long skull, round ears and massive jaws. The sphinx represents the ghoulish hyena of Chaos. There is a door between the great paws of the sphinx leading to an underground labyrinth.

State of Ruin: The huge walls that once encircled the city have crumbled. The great pylons of the gates, carved with the leering gargoyle masks of grinning monsters, are all that remain of the broken walls. Roofs have fallen in, buildings have decayed into mounds of crumbling mud brick.

Weird Element: Shadows seem to watch people who stay the night there.

Monsters/Guardians: Thoth-Amon keeps another residence here (as well as at Kheshatta, Luxur and the Oasis of Khajar). Nebthu is also said to be a secret headquarters of the Black Ring. Also the Ghoulish Hyena of Chaos guards the ruins (see *Conan: Stygia – Serpent of the South*).

QARNAK (RUIN)

On the banks of the Styx in eastern Stygia are the ruins of Qarnak.

Cultural Nature: Necropolis/Religious Centre.

Historical Nature: Abandoned when the proto-Stygians (the Khari) drove out the Giant-Kings.

Physical Nature: This ancient place consists of vast, abandoned temple-tombs carved by forgotten races into the crimson face of the river cliffs. Massive colossi look over the ruins and the river.

State of Ruin: Varies from tomb to tomb, from temple to temple.

Legends: Many tombs of Children of Set are said to be here, as well as tombs of the ancient Giant-Kings of old.

THURAN-ON-THE-HEIGHTS (RUIN)

Thuran-on-the-Heights is a ruin in Taia.

Cultural Nature: Religious (Mitra).

Historical Nature: Thuran-on-the-Heights is the holy city founded by King Varanghi in Taia. It was destroyed 500 years ago when Stygia conquered Taia again. The city was consecrated to Mitra and the Taiaans believe the city was destroyed for this reason. In truth, the Stygians had no clue which god the city was consecrated to – the Taiaans were considered 'squatters'. The Stygians were angered that someone had decided to live there without paying tribute to the Stygian king. This fertile region had been a Stygian controlled land since the fall of Elder Stygia. However, due to mismanagement and concentration elsewhere, the region was largely abandoned when King Varanghi arrived and built his city. The Stygians took note of the activity and reasserted their rights in the region. An old temple of the Sun god, half in ruins, but housing a few priests of Mitra still exists.

Physical Nature: A large mitraeum can be found here, as well as older more Stygian style ruins.

State of Ruin: Little remains of Thuran-on-the-Heights other than the half-ruined temple. It has been a ruin for over 500 years. Terraces have crumbled, walls have collapsed, canals and reservoirs have silted and men have carted off most of the stones.

TURAN

Shining Turan is probably the wealthiest nation of the Hyborian Age save Vendhya. The Turanian Empire is built upon the foundation of a large Hyrkanian force that swept out of the east on their horses, swinging around the Vilayet and finding that great inland sea to their liking. Turan is a vast empire of incredible size, virtually encompassing the Vilayet Sea by the time Conan is king of Aquilonia. All but the most northerly reaches of the Vilayet are controlled by Turan. The northern reaches are too mountainous and cold

for the Turanians to bother with. Turan borders Zamora, Koth, Shem and even sends forays into Hyperborea.

Turanian cities are among the most grand of the Hyborian Age. The *suks*, or open-air market places are a feast for the senses. Colours, textures, sounds, smells and even tastes assault from all directions. Scarlets, greens and turquoises smash headlong into shining silks and dingy cloths, which, in turn are set off by the bright shine of precious metals and the dull glint of iron and polished woods. Great towers glitter in the sun and stand brightly against the moon. Minarets and spires decorated with arabesques and fantastic designs stand proudly over the great palaces of marble and gold as vast caravan trains move toward the bazaars with the goods from a thousand cities from around the known world.

For most constructions, the Turanians generally use brick and wood, however their greatest works use dressed stone. Turanians make a lot of use out of stalactite vaulting and minarets. The inner and outer walls are decorated in a material made by mixing marble, powder, lime and plaster. In addition, mosaics and domes include exotic materials such as coloured stone, fancy woods, gold and mother-of-pearl. Their monumental buildings (generally temples, caravansaries, tombs and palaces) are elegantly simple and harmoniously proportioned. An imposing central dome dominates these monumental buildings. Descending half domes, vaults and ascending buttresses aesthetically lead the viewer's eye up and down the building. Monumental buildings are framed with slender minarets of brick. These monumental buildings are always surrounded by open courts to keep the monument from being devoured and obscured by the surrounding city sprawl.

Early Turanian designs are severely plain with elaborate decorations only around doorways. Later designs are more elaborately decorated all over.

Turanian buildings are logical and clear in design, and each part of a building is considered relative to the whole building. There is nothing unnecessary in a Turanian building, largely because Turanian architects receive their training as military engineers.

There are more than 30 standing fortifications built by Turan that have been abandoned in the last 200 years, either from war, drought, sorcery or monsters. Not all ruins in Turan are Turanian. Several examples of the long-lost 'green-stone culture' have been found on the Vilayet. Zhemri (Zamorian), Stygian and aboriginal ruins can be found throughout the steppe and desert lands of Turan.

Historical Elements: Turanians are descended from ancient Lemurians. They were brutish and enslaved but rose up and threw down their Khari masters (who would later turn up as Stygians). By trading with Khitai, the Hyrkanians

(as they now called themselves) became a powerful people. Racing across the steppe, they encountered the Vilayet. A particularly strong Hyrkanian tribe swung south of the inland sea and founded Turan. Turan now occupies land once belonging to the Zhemri and later to the Zamorians.

List of Known Turanian Kings: Yildiz, Yezdigerd

ALHMET (RUIN)

Alhmet was a Turanian satrapy in the eastern desert.

Cultural Nature: Trader/Warrior (Turanian).

Historical Nature: It was attacked by imperial forces for not paying taxes for two years.

Physical Nature: A circle of standing stones.

State of Ruin: The castle there is now nothing but a ring of scorched earth surrounded by a circle of standing stones.

Weird Element: Occasionally the sounds of the slaughter and the burning can be heard.

Legend: The treasury of Alhmet was hidden in the desert nearby by the satrap but was never found by the Turanians.

THE ISLE OF IRON STATUES

The Isle of Iron Statues is a small, oval island in the northern Vilayet Sea near the western shore with ancient ruins built of the great iron-like green stones found in the region. The largest ruin is a great hall where rows of iron statues stand. The island is avoided by the sailors of the Vilayet Sea. The northern shore of the island rises up to a series of cliffs that drop into the Vilayet. The Isle of Iron Statues is covered in detail on page 75.

XAPUR THE FORTIFIED

Xapur the Fortified is the island home of the extinct Dagonians. The Dagonians were a white race, although dark-skinned with black hair. The island rises out of the Vilayet in sheer cliffs 150 feet tall. Its interior is jungle.

Cultural Nature: Religious Centre (Dagonian).

Historical Nature: The city was founded by a thing from the Abyss named Khostral Khel, and it was worshipped by the Dagonians in grisly rites of human sacrifice. In the end, after their god was defeated, they were slaughtered in brutal revenge by the barbarians they had enslaved.

Physical Nature: A ruined city made of colossal green stones can be found here. Underground tunnels crisscross beneath the earth, perhaps hiding some ancient treasure. Near the middle of the ruins, slightly to the north of the isle's centre, a broad mound rises 20 feet above the surrounding jungle – the highest point on the isle. This mound is actually the still-intact domed inner sanctum of Khosatral Khel's palace. Long

buried in the debris of countless ages, the structure has lost its resemblance to a crafted building and instead appears as a rough mound choked with tumbled green blocks and jungle vegetation.

State of Ruin: The foundations of the wall, stumps of broken columns and a great dome remain.

Legends: The place is thought to be haunted or cursed by the local Yuetshi fishermen, but is sometimes used as a rendezvous for pirates and their Kozak allies.

Weird Element: If and when Khosatral Khel (see *Conan: The Scrolls of Skelos*) is restored to life, he uses his power to recreate the lost city he once ruled over. Dagon stands again, a glimmering walled-city of tall towers and domed minarets fashioned from colossal blocks of green stone.

VENDHYA

Vendhya's culture resembles that of the mythical India described in the Vedas and the people are divided into distinct classes, or castes. Except for the palaces and the temples, Vendhyan homes are cut from the same mould. Each one is made out of brick, stands one or two stories high and has a flat roof. Built around a courtyard, each Vendhyan home has windows facing into the courtyard; the exterior walls have no windows, for privacy is prized. Every home has its own well and a privy. Pipes of clay lead from the private bathrooms to an extensive sewer system beneath the streets, be it city, town, or village. These sewers then drain into rivers and streams nearby.

Early Vendhyan cities had well-planned cities and houses, complete with drainage/sewage systems and public baths. Most of these early villages include some sort of fort-like structure made of stone and metal. Strangely, these early villages had few to no temples whatsoever. Older style houses lacked the modern courtyard in the centre and had thatched roofs.

Of any age, Vendhyan towns and cities each have a large, central building for storing communal grain. Few Vendhyans are selfish enough to store their own grain. Food is for all to enjoy, not for hoarding.

Vendhyan temples are massive edifices. The principal shrine is always facing the rising sun and the primary entrance faces east. The temples are designed to emulate the idea that a person is leaving the temporal world into an eternal one by walking through the temple chambers.

There are a few rules. People may not wear any kind of footwear inside and feet must never point toward the gods or their emblems. When sitting, feet are to be folded. Vendhyans must never sit so that their back faces the inner sanctum. It is also not permissible to enter the

shrine or touch a deity's statue without permission from a priest.

Vendhya's beautiful temple, palace and tomb art appears very exotic to Hyborians. Paintings, carvings and sculptures feature hallowed, multi-armed gods and goddesses as well as inspiring mortal heroes. The art is embellished further with dazzling arrays of spirals and curvaceous lines, including vines, tendrils, arches and domes, each detailed in painstaking exactness. Most monumental buildings (mostly temples, tombs and palaces) feature finials (crowning elements on a dome), a lotus decoration on the top of domes that supports the finial, onion domes, drums (cylindrical bases holding up the dome), decorative spires attached to the edges of supporting walls, domed and columned kiosks, decorated upper panels of arches, calligraphy, arches and decorative sculpted panels to line the lower walls of the monument.

Historical Elements: For 800 years an aboriginal culture flourished on the Vendhyan sub-continent. 2,500 years ago, this culture fell into a decline and was crushed by a nomadic northern people called the Kshatriya, led by King Orissa.

KHORALA (RUIN)

Khorala is a ruined city deep in the jungles of Vendhya.

Cultural Nature: Agricultural/Trader (aboriginal)

Historical Nature: Khorala was founded 3,100 years ago. It grew for 130 years before a natural disaster nearly destroyed it. A limnic eruption in the nearby lake killed almost the entire population. For twenty years, the city lay abandoned but for a few hermits and grave-robbers. The city was re-established and a grand temple unlike any seen before was built to protect the city. Five hundred years later, the Rishi of Khorala became a powerful sorcerer and made a certain ring for his daughter so she could rule the city through the Khoralan king. After 160 years, the Grand Palace was built over the old palace, which had been destroyed by a minor earthquake (which set off another limnic eruption, but the earthquake sent people fleeing from the city, so many survived to rebuild). The city was then defeated by King Orissa and his Kshatriyas. The people were taken to Maharashtra to work as slaves and Khorala was forgotten.

Physical Nature: Khorala is an oval city; the Grand Temple of Khorala and the Grand Palace are the foci of the oval. The streets are mostly straight, running either to the temple or to the palace. The city has a wall around it, decorated in multi-trunked elephant carvings. Typhoons periodically smash into the city.

State of Ruin: The ruin is mostly overgrown. Some of the minarets and walls have toppled but the grand monuments have stood the test of time well, although they are now festooned with vines and trees.

Weird Element: Sometimes people just suffocate there, especially after an earthquake (which sets off limnic eruptions in the nearby jungle lake).



Legends: It was from here that the ring known as the 'Star of Khorala' originated. Other great and sorcerous treasures created by the Rishi of Khorala of that time period are said to be hidden within the ruins.

Monsters/Guardian: A hermit dwelled here alone as a sorcerer.

MAHARASHTRA (RUIN)

This is an ancient city of Vendhya. In time it was absorbed by the Forest of Ghendai and its location lost.

Cultural Nature: Capital (Kshatriyan)

Historical Nature: Two thousand years ago, this was the city of the first Vendhyan King, Orissa. When he died, he was worshipped as a god in a temple built over his tomb. Five hundred years later, the city was sacked and abandoned.

Physical Nature: Maharashtra is a large ruin of an enormous city hidden by the forest. Most of the city is completely gone, so the ruins are smaller than the original city.

State of Ruin: Overgrown and toppled. The city looks 'as though some malevolent god, unwilling to wait for the slow wearing away by rain and wind, had commanded the forest to attack and consume all marks of men.' The streets are covered in dirt and humus and the trees of the tall forest surrounding the ruin have grown everywhere. The temple of Orissa has collapsed.

Legends: There is a prophecy that the 'army that will not die' will march from Maharashtra at the end of time. Also there is said to be a great bejewelled gold crown forged from all the crowns of the peoples Orissa conquered.

Monsters/Guardians: The Sivani (demons) protect the temple of Orissa, keeping Masrok from escaping. Masrok, a great eight-armed demon lord, is also locked in the city somewhere, buried under the collapsed temple of Orissa.

ZAMORA

Zamora is an ancient kingdom, descended from a mysterious race known as the Zhemri, an elder and evil race from pre-Cataclysmic times. The fortunes of the Zhemri and, later, Zamora rose and fell constantly. The ancient origins of Zamora causes them to look with some disdain upon Hyborians and their barbaric origins. Some of the noble lines in Zamora can trace their lineage back to the earliest of the Zhemri families, a heritage extending far beyond any known Hyborian family line. Locked in vaults and in private libraries, mouldering tomes detail periods of time so ancient as to cause the mind to reel with the magnitude of history. Many Nemedian scholars long to get even a peek at some of these family histories for their own essays and researches. Currently the several thousand year old civilisation has fallen into decadence and its



people are viewed as a wicked race of thieves, cutthroats and sorcerers. More information on Zamora and its thieves can be found in the *Conan: Shadizar – City of Wickedness* boxed set.

Zamorian cities are gorgeous from a distance, built of alabaster spires, golden domes and jewelled towers. The cities glitter in the night and shine during the day. Up close and personal, the streets are practically random and refuse often clogs the streets in the worst parts of town. The cities are structured into districts. With Zamorian ruins, the temple districts and the palaces survive the longest – the mean parts of town usually disintegrate quickly. Most Zamorian cities are built with walls around them as they live in a hostile world with no allies.

There are approximately 180 fortifications, piles of ancient stones, and ruins abandoned throughout Zamora. Some are horrifically ancient Zhemri ruins, others are Zamoran ruins destroyed by war, sorcery, drought, disease or famine. Bandits live in a few, others have become the lair of Zamora's infamous spiders.

Historical Elements: Zamorian history begins in the time of Valusia and Atlantis as the people of Zhemri, which may have been part of Grondar. When the Cataclysms rocked the earth, the Zhemri survived and degenerated to a stone age existence. The Zhemri, a diabolic race to begin with, sought to revive their ancient culture, which they knew only from an oral tradition. For a thousand years the Zhemri struggled, mining old ruins for artefacts and icons. The knowledge of the ancients was found and eventually the civilisation traded with Acheron and Stygia, and had a similarly evil reputation.

AMANAR'S KEEP (RUIN)

The sorcerer Amanar dwelled in this Dark Fortress (as it was dubbed by the local tribesmen) deep in the Kezankian Mountains of eastern Zamora. It lies several leagues north of a mountain pass used by caravans heading to Sultanapur.

Cultural Nature: Scholarly (Zamorian).

Historical Nature: It was ruined when the mountain exploded at the end of *Conan the Invincible*.

Physical Nature: It is a bleak, stone fortress carved out of the granite flank of a nameless mountain.

State of Ruin: Blasted and half-buried by an earth-slide.

Legends: The hillmen, though fearless by nature, ride leagues out of their way to go around this black citadel, making the sign of the horns to ward off evil at its very mention. Its half-buried ruins may well hold relics or magical energy, at the Games Master's discretion.

DAGOOTH HILL (RUIN)

The demon-haunted location known as Dagoth Hill is the site of pre-human ruins. Vile demons still dwell here, willing to enter into sorcerous pacts or lie with women to continue their foul lineages. See page 64 for more details on Dagoth Hill.

LARSHA (RUIN)

Larsha is a ruined city near Shadizar.

Cultural Nature: Unknown (Zhemri/Giant-King).

Historical Nature: Built in Cataclysmic times by the Zhemri and was ruled by Giant Kings. In Conan's youth, after his adventure within the walls of Larsha, the city was largely destroyed by an earthquake.

Physical Nature: In the centre of the city stood a royal palace carved out of a massive crag. That monolithic black basalt palace is now nothing more than a huge hill of rubble. If any passages or chambers still exist beneath the vast broken blocks they remain hidden to this day.

State of Ruin: The severe damage of the earthquake has reduced the city to rubble, yet people still avoid the ill-reputed ruin, afraid of lingering curses.

Legends: Legends tell of great treasures and a horrible curse lurking within.

Monsters/Guardians: Within this darksome ruin lurk the mummies of the Giant Kings that eternally guard their treasures. Conan encountered seven of them; they were, he discovered, destroyed instantly by sunlight.

PULAWER (RUIN)

Pulawer was an ancient city-state of the Janagar Empire.

Cultural Nature: Janagar.

Historical Nature: Pulawer of the Opal Gates was at its height when Python was still a crude village. Destroyed by magic over one thousand years ago. One king is known as King Ardubal IX.

Physical Nature: All that remains of this Janagar city is a ruined temple in northern Zamora. Thought by local legends to have been the temple of King Ardubal IX, the temple is erroneously called the Ardubal Temple. All the streets around the temple are short, punctuated by random flights of stairs to squares and courtyards. The artwork is decadent, revealing how the Janagar worshipped gods of blood and fertility.

State of Ruin: The ruins are ramshackle, with no straight roads.

Legends: Most legends tell tales about the temple of King Ardubal IX.

ZINGARA

Zingara is a land torn apart and ruined by civil war. Under a dazzlingly complex political system, dukes and counts rule fiefs in the name of the King in Kordava, although in most cases that fealty is, at best, nominal and somewhat confusing. The nobles of Zingara are a proud, individualistic race, not given to subservience. They rebel both openly and secretly. Today, Zingara is a faltering anarchy. Manners and pleasures in Zingara are elements of their elegance and sophistication. Ballet troupes learn the finest dances in the schools and the fine art of fencing was taught to all noblemen. Waving scented handkerchiefs, the nobility of Zingara plots and conspires against fellow nobles even as they talk elegantly of philosophy and civility.

Most temples of Mitra in Zingara are converted from older gods and religions. Temples to Mitra are plain almost to the point of austerity. Precious metals and stones may be used but only in simple forms, such as a square altar of solid jade but otherwise undecorated. A single depiction of Mitra is normal here, usually on a pedestal and depicted as a tall man, handsome, bearded, and very dignified. They are called mitraea and are similar in most respects to Argossean mitraea as shown on page 26, save they are less cave-like and more cathedral-like.

Zingaran homes are characterised by low-pitched roofs with red tiles and no overhanging eaves. The sides are usually stucco and the overall design utilises a lot of arches, especially over doors, entryways and windows. Cross-gables and side wings create an asymmetrical shape common among Zingaran houses, and many of the wealthier homes include parapets and flat roofs. Doors are usually engraved or carved into designs and the home usually has spiral columns. Floors are usually patterned tiles. Most houses are two, three or four-storey buildings with front and back terraces, sharing larger courtyards and gardens with their neighbours. These gardens usually include fruit orchards.



The wealthy in Zingara own flats in the cities as well as a chalet or villa out in the country overlooking their southern plantations. Zingaran flats are houses without gardens used by merchants who stay in the city. The ground floors of most flats are designed for businesses, shops, restaurants and taverns. The chalets and villas are country estates with an old house surrounded by manorial land, complete with olive, orange and lemon groves and expanses of wooded areas. Zingaran villas are characterised by indoor patios and large, vined terraces.

There are a huge number of ruins in Zingara. About 19 cities, 90 towns and possibly as many as 10,000 villages have been razed in the civil war, mostly in

FAITH AND FERVOUR



the north. Zingaran ruins can also be found on islands and in the form of sunken ships beneath the waves of the ocean.

Historical Elements: 300 years ago King Gitara III (and high councillor Elsin Ataro) ruled Zingara. King Ferdrugo de Ramiro III is the last of the Zingaran kings before years of civil war ravaged the nation. He ruled Ramiro, a large district of Zingara, for years before becoming king of the entire united nation. He took the throne after the death of King Mordermi, a tyrannical usurper who caused the death of King Rimanendo.

Known Rulers of Zingara: King Gitara III (300 years ago), King Rimanendo (during Conan's youth), King Mordermi, King Ferdrugo de Ramiro III (most of Conan's adult life), Queen Chabela de Ramiro & King Olivero de Hareje.

CASTLE OF VALBROSO (RUIN)

Valbroso was a Zingaran count who controlled a castle and manors on the short route from Poitain to Messantia. Before his death, Count Valbroso intended to take his men-at-arms and head south to serve as mercenaries.

Cultural Nature: Warrior (Zingaran).

Historical Nature: The castle was founded centuries ago during a war with Poitain. It was captured by Poitanian knights about a hundred or so years ago and ransomed back to the founding family. Valbroso died during the events of *The Hour of the Dragon*. His manors and lands are slowly starving. His castle is falling into ruin and, since his death, has been deserted.

Physical Nature: The castle is a Medium sized building with walls, a keep and some internal buildings.

State of Ruin: Intact but starting to fall apart. The moat is dry, half filled with debris.

Legends: Bandits store loot in the castle and some of the Count's heirlooms are still located within.

Monsters/Guardians: It is now a bandit's keep.

CITY OF THE GHOULS (RUIN)

The ruined City of the Ghouls is described in detail on page 55.

SADORIA (RUIN)

Once known as the garden spot of western Zingara, it was destroyed by the war, and every able bodied male over the age of five was put to the sword.

Cultural Nature: Artistic/Noble (Zingaran).

Historical Nature: Sadoria was founded 80 years ago as a garden spot for Zingaran nobles and artisans to enjoy and relax. It was destroyed by the civil war and its people slaughtered or enslaved.

Physical Nature: Sadoria was a small, sprawling city built along topographic lines. Streets meandered around in an almost lazy manner. Public baths, gorgeous gardens and courtyards, beautiful mitraeums and fantastic landscaping typified this pretty Zingaran town.

State of Ruin: Intact but burned & looted.

VALADELAD (RUIN)

Valadelad was a coastal town of Zingara.

Cultural Nature: Trader/Pirate (Zingaran).

Historical Nature: The city was founded 200 years ago along a trade route for local vineyards. An ancient temple was found and converted into a mitraeum. A great warrior was born in Valadelad and fought at the king's side 120 years ago and was posthumously rewarded by the king with a fantastic and ornate statue of Mitra for his people. Conan burned the town prior to the sinking of his ship by the Zingaran navy.

Physical Nature: Valadelad was a small coastal town that was topographic in shape, bounded on one side by the ocean and the other by three hills. A wall was in the process of being built when Conan and his pirates attacked.

State of Ruin: Burned and looted. It has not been rebuilt yet because of the demands of the civil war.

Legends: Conan's pirate ships were chased off by the Zingaran navy before he and his pirates could loot the Saint de Aventura mitraeum, which is said to have a golden statue of Mitra slaying a giant scarab of Set. The golden statue is said to tread upon a silver serpent. A golden bow and club lay in front of the serpent between an ivory statue of a pair of male twin children (with a small dog in one's arms and a rabbit in the other's arms) and an ivory bull statue.

City of the Winged One

THE HORROR ON THE ZARKHEBA

QUEEN OF THE *Black Coast* is one of the greatest of Robert E. Howard's *Conan* stories. It features a huge ruin wherein Bêlit meets her doom.

HISTORY

The City of the Winged One was built in the dawn of time, long before humanity rose to walk the surface of the earth. The city, built of dark green stone, was raised alongside a wide river on a huge plain. The creators of the city were not human. Howard described them as 'cast in the mould of humanity, they were distinctly not men. They were winged and of heroic proportions; not a branch on the mysterious stalk of evolution that culminated in man, but the ripe blossom on an alien tree, separate and apart from that stalk. Aside from their wings, in physical appearance they resembled man only as man in his highest form resembles the great apes. In spiritual, aesthetic and intellectual development they were superior to man as man is superior to the gorilla.'

These beings lived and died in this city for millions of years. When the poles shifted and the world changed, their own world was ruined. The river along their city was poisoned and

their plain turned into jungle. Many died from drinking the water but those who lived altered. They became corrupted and their bodies underwent grisly changes. Their vast knowledge became perverted and horrid and many became cannibals. This continued until only one remained.

The city was undisturbed throughout the remaining thousands of years until the pre-historic Stygians pushed south. Fifty warriors found the city and were enslaved by the remaining Winged One, turned into horrible were-hyenas. The city remained a rumour thereafter – until Bêlit and Conan decided to sack it.

The trip to the city was a doomed one. Conan alone walked out of the city alive – and with his passing, so ended the history of the first people of the world, for Conan slew the last Winged One in his vengeance.

LAYOUT

The City of the Winged One is reached by travelling the poisoned waters of the Zarkheba River, a broad and sullen river along the Black Coast. The river is dark and murky, home only to venomous reptiles. No native tribe lives along its jungle-clouded shorelines. There are no crocodiles, birds or four-legged beasts of any kind inhabiting the mysterious river or its environs.

The city of dark green stone itself is a broken ruin that is quickly being taken over by the surrounding jungle. Broken piers jut into the Zarkheba River and shattered paves line what were once streets, spacious plazas and broad courts. Great mounds of rubble and buckling towers are all that remain of most of the buildings. A marble pyramid with a slim spire on its pinnacle looms in the centre of the city. Massive altars can be found throughout the city, complete with channels for the spilled blood along their sides. Many of these altars have traps to protect the treasures beneath them.

TRAPS

The trap most associated with the City of the Winged One is the crushing tower trap, which was triggered when Bêlit's crew moved an altar aside. Other traps likely include built-to-collapse walls and pit traps (see page 126).

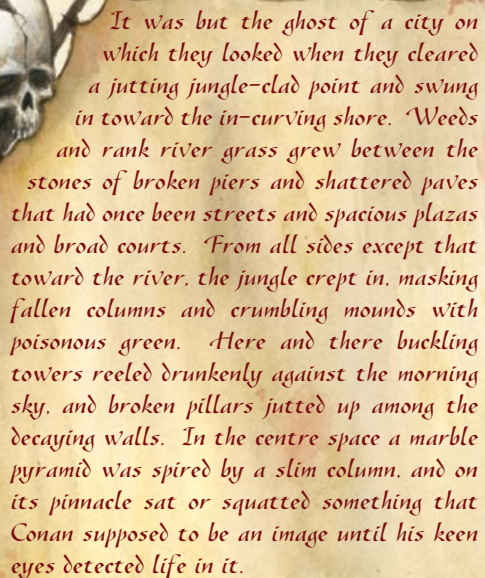

It was but the ghost of a city on which they looked when they cleared a jutting jungle-clad point and swung in toward the in-curving shore. Weeds and rank river grass grew between the stones of broken piers and shattered paves that had once been streets and spacious plazas and broad courts. From all sides except that toward the river, the jungle crept in, masking fallen columns and crumbling mounds with poisonous green. Here and there buckling towers reeled drunkenly against the morning sky, and broken pillars jutted up among the decaying walls. In the centre space a marble pyramid was spired by a slim column, and on its pinnacle sat or squatted something that Conan supposed to be an image until his keen eyes detected life in it.

Robert E. Howard, *Queen of the Black Coast*

ZARKHEBA

will likely contain the secrets to the spell *awful rite of the were-beast*.

TAINED TREASURES

Virtually all the hidden treasures in the City of the Winged One are worth as much as a king's ransom, well in excess of 10,000 golden crescents. Thus, any character finding one of the treasure crypts here must immediately make a Will saving throw with a DC of 15 + 1 per additional 10,000 golden crescents beyond the first. Failure indicates that the character becomes distracted for the next 2d6 rounds, with a -4 circumstance penalty to all Listen, Spot and Search rolls that do not relate directly to the treasure.

If the treasure in question is cursed or magically tainted in any way, which includes all treasure found in the City of the Winged One, this Will saving throw is considered to be a Corruption saving throw in every way, including the lack of bonus for the No Honour feat, increased bonus for Code of Honour, penalties for Corruption points and Corruption gain if failed. The usual penalties (above) apply but in addition any character who fails will become obsessed with

the treasure on a more long-term basis, spending at least the next hour concerned only with securing, counting or looking at the treasure, as appropriate. While in this state he may only take either a move or a standard action each round and is at a -2 circumstance penalty to all attack rolls and skill checks other than Appraise checks. After an hour, he may attempt another save as before, success indicating that he shakes off the effects.

Note that this can affect even the wealthiest characters. In *Queen of the Black Coast*, Bêlit and her crew are already rich on the treasures plundered from dozens of coast towns and merchant ships all up and down the Black Coast, yet they are still obsessed with acquiring more...

Built-to-Collapse Wall: Proximity trigger; no reset; Atk +20 melee (8d6, stone blocks); multiple targets (all targets in a 10-ft.-by-10-ft. area); Search DC 14; Disable Device DC 16.

Crushing Tower Trap: Location trigger; automatic reset; no attack roll required (18d6, crush); multiple targets (all targets in a 20-ft.-by-30-ft. area); Search DC 20; Disable Device DC 25.

MAGIC & UNUSUAL ITEMS

The treasures of the City of the Winged One are uncountable. Bêlit only looted one crypt. Presumably there are others – it is unlikely she would have found the only treasure on her first attempt. The Games Master can easily place virtually anything here.

Ancient spell books with the magic of the old ones can probably be found here and

WATER OF ZARKHEBA

The waters of the Zarkheba river are a deadly poison (Ingested DC 25 Fort, with 2d6 Con damage initially, followed by 1d6 Con plus Corruption as secondary damage). The secondary damage is notable because, in addition to the Constitution damage inflicted by drinking the water, the secondary damage includes Corruption – the drinker is filled with unnatural, evil thoughts, tempting him to turn from goodness. Any

creature drinking the waters of Zarkheba and who must make a Fortitude save against the secondary damage must also make a Corruption save (DC 25, as for the Fortitude save; all the usual Corruption bonuses and penalties apply) or gain 1 point of Corruption.

The waters are extremely foul-tasting, and so are rarely used to poison someone secretly, since the victim will not down a full dose voluntarily. However, some groups or individuals may slay an enemy by simply throwing him in the river, or collect a dose and force-feed it to a particularly hated individual. The death it causes is swift but agonising.

Waters of the Zarkheba do not retain their potency for long when removed from that dread channel, indicating that some spell or curse may be partially responsible for the poison. Removing the water from the river immediately reduces the initial damage to 1d4 Con and removes the Corruption effect of the secondary damage. Furthermore, each day after it was drawn from the river, the Zarkheba river water's damage is reduced by 1 point. For this reason the water has no especial resale value as a poison – the buyer can never be certain as to how potent the water will be by the time it reaches him.

MONSTERS OF THE CITY OF THE WINGED ONE

Queen of the Black Coast features three memorable monsters in the region of the City of the Winged One: the black lotus, the Winged One himself and his were-hyena guardians. All were presumably slain by Conan the Cimmerian during the events of *Queen of the Black Coast* but that does not necessarily have to be the case. Perhaps a sorcerer summons another Winged One out of the depths of time to learn its secrets or maybe one of the were-hyenas escaped – human now because of the death of the Winged One and perhaps quickly aging, but he knows where the city is and where the greatest treasures lie. Letting characters find unguarded treasures is not recommended, so some sort of guardian should take up residence after the death of the Winged One.

BLACK LOTUS

Large Plant

Hit Dice: 4d8+20 (38 hp)

Initiative: +7 (+3 Dex, +4 Reflex save)

Speed: 0 ft.

Dodge Defence: 13 (–1 size, +3 Dex, +1 natural)

DR: 2

Base Attack/Grapple: +3/+3

Attack: Touch +5 melee finesse (poison)

Full Attack: Touch +5 melee finesse (poison)

Space/Reach: 10 ft. (2)/10 ft. (2)

Conan suddenly realised that the air was impregnated with an alien and exotic scent. Something gently brushed his temple. He turned quickly. From a cluster of green, curiously leafed stalks, great black blossoms nodded at him. One of these had touched him. They seemed to beckon him, to arch their pliant stems toward him. They spread and rustled, though no wind blew.

Robert E. Howard, *The Queen of the Black Coast*

Special Attacks: Magical poison, miasma, poison

Special Qualities: Low-light vision, plant traits

Saves: Fort +9, Ref +4, Will –3

Abilities: Str 2, Dex 16, Con 20, Int –, Wis 2, Cha 26

Skills: –

Feats: –

Environment: Warm jungle

Organisation: Patch (5–10) or colony (11–30)

Advancement: 5–6 HD (Large)

Black lotus plants have a weird, semi-sentient life of their own, which can prove hazardous. Certain sorcerers and supernatural creatures may exploit the living black lotus' properties so as to drug their victims or capture prey.

Black lotus plants are green in colour, but with the infamous black blossoms heading each stalk. Black lotus plants can grow to over 12 feet in height.

Combat

Though black lotus plants are stationary, their stalks and blossoms are capable of deliberate and fast movement, allowing them to attack in a primitive manner.

Magical Poison (Su): The poisonous miasma (see below) given off by black lotuses is partially physical and partially magical in effect. The black lotus has a strangely seductive quality that seems to make passers-by deliberately want to inhale its poison. This allows the black lotus to add its Charisma bonus to the save DC of its miasma attack (see below).

Miasma (Su): Black lotus plants constantly give off a heady scent that forces all within 20 feet of the plant to make Fortitude saves (DC 25) or be affected as by inhaling black lotus blossom (see *Conan the Roleplaying Game*). The save DC is Constitution-based, but

ZARKHEBA

due to the effects of the black lotus' magical poison special attack, it may also add its Charisma bonus to the save DC.

Poison (Ex): Contact, DC 17, initial and secondary damage 1d4 Con. The save DC is Constitution-based. Note that this poison is essentially a less concentrated form of black lotus juice (see *Conan the Roleplaying Game*).

THE WINGED ONE

Scholar 12/Barbarian 5

Large Humanoid (corrupted)

Hit Dice: 10d6+30 plus 2 plus 15 (82 hp)

Initiative: +12 (+2 Dex, +10 Reflex)

Speed: 30 ft. (6 squares), fly 30 ft. (good)

Dodge Defence: 18 (-1 size, +2 Dex, +7 level)

Parry Defence: 22 (-1 size, +8 Str, +5 level)

Damage Reduction: 2

BAB/Grapple: +14/+26

Attack: Slam +21 melee (1d6+8)

Full Attack: 2 slam attacks +21melee (1d6+8)

Space/Reach: 5 ft. (1)/5 ft. (1)

Special Attacks: Crimson mist, sorcery, versatility (-2 penalty)

Special Qualities: +3 power points, advanced spells x10, base power points, bite sword, bonus spells x3, fearless, increased maximum power points (triple), independent background, knowledge is power, new sorcery style x5, old one traits, scholar, trap sense +1, uncanny dodge

Saves: Fort +11, Ref +10, Will +12

Abilities: Str 26, Dex 15, Con 16, Int 24, Wis 16, Cha 20

Skills: Climb +12, Concentration +17, Craft (alchemy) +22, Craft (herbalism) +26, Decipher Script +22, Handle Animal +17, Heal +12, Hide +6, Intimidate +25, Jump +16, Knowledge (arcana) +25, Knowledge (local) +22, Knowledge (nature) +22, Knowledge (astronomy) +22, Listen +22, Move Silently +16, Perform (ritual) +24, Search +16, Spot +22, Survival +16



Feats: Crushing Grip, Flyby Attack, Improved Grapple, Iron Will, Mobility, Power Attack, Ritual Sacrifice, Tortured Sacrifice, Track

Code of Honour: None

Reputation: N/A

Leadership: -

Allegiances: None

Base Power Points: 7 (4 base, +3 Wis, +3 bonus, -3 obsession; 21 maximum)

Magical Attack: +12 (+7 level, +5 Cha)

Sorcery Styles: Curses, Summonings, Nature Magic, Divination, Cosmic Sorcery

Spells Known: *Animal ally, astrological prediction, awful rite of the werbeast, children of the night, control magical beast, control monstrous humanoid, demonic pact, greater demonic pact, dream of wisdom, greater summon beast, lesser ill-fortune, sorcerous garden, summon beast, summon demon, the time is right, the stars are right, visions, visions of torment and enlightenment*

Corruption: 12 (corrupt; gained slam attack and ape-like attributes)

Insanity: Cannibalism, obsession with protecting his city

Possessions: None

With fearful speed it was rushing upon him, and in that instant Conan had only a confused impression of a gigantic man-like shape hurtling along on bowed and stunted legs: of huge hairy arms outstretching misshapen black-nailed paws: of a malformed head, in whose broad face the only features recognizable as such were a pair of blood-red eyes. It was a thing neither man, beast, nor devil, imbued with characteristics subhuman as well as characteristics superhuman.

Robert E. Howard, *Queen of the Black Coast*

The Winged One is a stunted abhorrent perversion of nature, the last member of the oldest race in the world. It has huge hairy limbs, bat-wings, bowed and stunted legs, black-nailed paws and a malformed head. It stands over 6 feet tall and weighs 400 lbs. His wingspan is immense in order to hold up his weight.

The Winged One is the last of a dead race. The race of the Winged One was originally cast in the mould of humanity yet they were not men, resembling men only as much as men resemble gorillas. They lived here before man rose from the slime of the primordial seas but they fell into decay and decline and their knowledge was twisted along ghastly paths. The last one, the strongest of his kind, remained.

Ages passed before fifty pre-historic Stygians came upon the city where the last Winged One lived. As they slept beneath the red blossoms of the ruins, the Winged One performed weird and awful rites on each sleeper and turned them into were-hyenas under his command.

Thousands of years later, the Winged One killed Bêlit and, in turn, was slain by Conan the Cimmerian. The fiend was cut in half by Conan's sword.

And now from the shadows dark shapes came silently, swiftly, running low - twenty great spotted hyenas. Their slavering fangs flashed in the moonlight, their eyes blazed as no true beast's ever blazed.

Robert E. Howard, *Queen of the Black Coast*

WERE-HYENAS

Borderer 2/Soldier 2

Medium Humanoid (Stygian, Shapechanger)

Reputation: N/A

Leadership: –

Code of Honour: None

Allegiances: None

Possessions: None

The were-hyenas are the slaves of the Winged One, but they will not hesitate to slay their master if they can.

ZARKHEBA



	Human Form	Hyena Form
Hit Dice	4d10+8 plus 3d8+12 (55 hp)	4d10+8 plus 3d8+12 (55 hp)
Initiative	+10 (+1 Dex, +9 Reflex)	+12 (+3 Dex, +9 Reflex)
Speed	30 ft. (6 squares)	50 ft. (10 squares)
Dodge Defence	16 (+1 Dex, +3 level, +2 natural)	18 (+3 Dex, +3 level, +2 natural)
Parry Defence	15 (+2 Str, +3 level)	—
DR	4	6
Base Attack/Grapple	+6/+8	+6/+12
Attack	Khopesh +9 melee	Bite +12 melee (1d8+6, AP 5)
Full Attack	Khopesh +9/+4 melee	Bite +12 melee (1d8+6, AP 5)
Special Attacks	Combat style (archery)	Trip
Special Qualities	Animal empathy, favoured terrain +1, low-light vision, scent, stygian qualities	Animal empathy, low-light vision, scent
Space/Reach	5 ft. (1)/5 ft. (1)	5 ft. (1)/5 ft. (1)
Saves	Fort +13, Ref +9, Will +1	Fort +13, Ref +9, Will +1
Abilities	Str 14, Dex 12, Con 14, Int 11, Wis 10, Cha 9	Str 22, Dex 16, Con 18, Int 11, Wis 10, Cha 9
Skills	Climb +6, Handle Animal +1, Hide +6*, Jump +5, Knowledge (geography) +3, Knowledge (local) +2, Listen +4, Move Silently +7, Perform (ritual) +1, Search +1, Spot +4, Survival +6	Climb +10, Handle Animal +1, Hide +8*, Jump +17, Knowledge (geography) +3, Knowledge (local) +2, Listen +4, Move Silently +9, Perform (ritual) +1, Search +1, Spot +4, Survival +6
Feats	Alertness, Endurance, Rapid Shot, Self-Sufficient, Stealthy, Track, Weapon Focus (khopesh)	Same as human form

*Were-hyenas have a +4 racial bonus on Hide checks in areas of tall grass or undergrowth, which is already calculated in.

Combat

A favourite tactic is to send a few individuals against the foe's front while the rest of the pack circles and attacks from the flanks or rear.

Trip (Ex): A hyena that hits with its bite attack can attempt to trip the opponent (+2 check modifier) as a free action without making a touch attack or provoking an attack of opportunity. If the attempt fails, the opponent cannot react to trip the hyena.

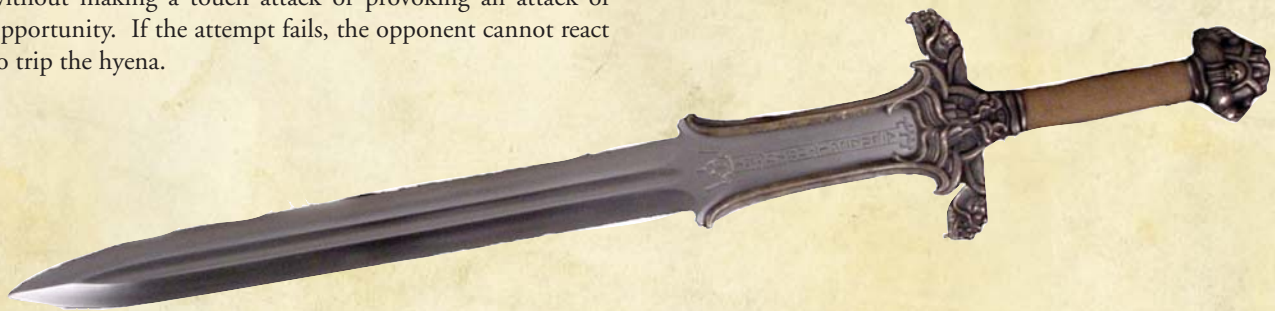

City of the Ghouls

ACCURSED RUIN LOST IN A HAUNTED FOREST

LOCATED IN THE hills that form the Argossean-Zingaran border, the City of the Ghouls lies hidden in a primitive forest.

HISTORY

The City of the Ghouls began as a settlement of aboriginal refugees after the fall of Acheron. They were neither Acheronian nor Hyborian. A legendary hero-king led the refugees to this site, claiming he was led here by a series of omens. He built the city out of stones carted away from Acheronian cities that had fallen to Hyborian warriors. A period of war was entered into as other refugees attempted to take the resources this site controlled.

During the era of the wars, the people captured their enemies and enslaved them, brutalising them and living lives of leisure off the sweat of their slaves. The slaves erected the city and its monuments and could not enjoy any of it. Only the select slaves of the noble families could even enter the higher tiers of the city – all other slaves were forced to live on the lowest tier or even outside the city walls in huts and shanties. Males who were deemed too unruly to accept slavery were forced to fight in an arena to the death – survival meant their freedom. The slaves suffered and the wealth of the city grew.

Half-forgotten memories surged back, of grisly tales whispered of the shapes that haunted these uninhabited forests at the foot of the hills that mark the Zingaran-Argossean border. Ghouls, men called them, eaters of human flesh, spawn of darkness, children of unholy matings of a lost and forgotten race with the demons of the underworld. Somewhere in these primitive forests were the ruins of an ancient, accursed city, men whispered, and among its tombs slunk grey, anthropomorphic shadows – Conan shuddered strongly.

Robert E. Howard, *The Hour of the Dragon*

A great priest rose among the slaves and he summoned a god to the world to fight for them – but he required a dark price, a price of blood and soul. The demon-god wanted a new race and he wanted the slaves to breed with his devils and bring about this new race. The male slaves, who were few in number, gave up their women to the devils from the underworld and watched, danced and celebrated as the girls, young and old, were bred to the devils in massive orgies that impregnated each woman, no matter how young or old. The barren became fertile and the fertile conceived monsters. The spawn in their bellies controlled their hungers, however, and the women turned on the men and their masters and devoured them. Many failed and were put to the sword, but their offspring would claw their way from the wombs after their mothers were buried in the graveyards, living on the corpses they found.

A great comet appeared in the skies and doom was foretold to the kings of the city in the forest by the priests, who ordained that the slaves would overthrow their masters. The kings and lords assembled their hosts and went into the lower city and into the underground warrens to slaughter the slaves only to find themselves ambushed and eaten alive. For months the people lived in terror as the horrid offspring of their former slaves slunk from the graves and mausoleums and the basements of their former homes. Those that tried to flee were caught in the woods by the inbred monstrosities who were made to live outside the walls. Women were captured and given to the demons and ghouls for more breeding.

Survivors attempted to barricade themselves into their homes, their lives becoming an ever-growing terror, but the ghouls did not stop. Eventually all the noble classes were devoured.

LEGENDS

Some people claim the original mothers are kept alive by the demons, all these thousands of years, never aging, always in pain, and perpetually within the cycle of birth.

The wealth of the city founders still exists in the city, guarded by the ghouls. Some of the treasure is looted from fallen Acheronian cities, carried off by the aboriginal founders of the city who fell upon the Acheronian remains like jackals.

CITY OF THE GHOULS

CITY OF THE GHOULS



LAYOUT

The walls of City of the Ghouls were built from the purple stones of Acheronian cities, looted and carted off after the Hyborians razed them. Thus, the walls are purple. At the heart of the city is the purple citadel of the ghouls. The citadel is indeed a ruin but it is largely intact. Time is wearing down the battlements but the ghouls are maintaining it somewhat. The citadel is built on top of a large mound of earth, now largely overgrown. Trees, vines and grasses cover the slopes from the walls below to the keep itself. Each tier of the city above the outer city is built on a mound of earth and stone that raises it by 10 feet above the previous, except for the castle motte, which raises the citadel up 40 feet above the grand temple tier. The mottes, after being raised, were covered in clay and reinforced with wood beams.

The buildings, walls and towers all have spurs and curving blades along the corners, giving the whole city a sharp aspect, as though built out of purple and stone axes and swords. Instead of standard medieval style battlements with merlons and embrasures, the walls of the City of the Ghouls has purple statues of cloaked men with swords or other weapons standing at regular intervals, providing the same utility as a merlon on a battlement, with the spaces between the cloaked statues serving as embrasures. Many of the statues are crumbled, fallen or otherwise ravaged by time. Each statue is somewhat unique in facial feature but all are frightening to behold – and often look like standing troops from a distance. The walls are also set with drum towers at irregular intervals; every other drum tower is fitted with a sharp-edged turret. Each of the towers on the central castle is fitted with a turret, although three of them have collapsed outwardly – their rubble lays mostly against the wall at the base of the castle motte.

The streets are a hopeless maze of broken stones, small trees, weeds, stagnant puddles and underbrush. Few residential buildings are intact and most (60%) are single storey affairs. Others are taller and there are several spires and towers. The western side of town, where the wall and the buildings have been effectively reduced to rubble, also serves as the ghouls' waste dump, so piles of bones and garbage are strewn all over the western part of the city.

- A. **The Great Hall:** Includes the throne of the Ghoule King and a stairway up into a tower overlooking the inner courtyard. The dining hall is beneath the Great Hall.
- B. **The Kitchens:** At one time, food was cooked here. The roof has since fallen in.
- C. **Royal Quarters:** These are old living quarters. The Ghoule King and his retinue still reside here among decaying splendour.
- D. **Servants' Quarters:** Servants lived in this lesser hall, along with clothing presses and other elements of their chores.
- E. **State Apartments:** These are old living quarters
- F. **Chapel:** This building is completely demolished; it was for the honour of a god even the ghouls have forgotten the name of and dates to a time prior to the coming of the demon-god.
- G. **Unknown**
- H. **Inner Courtyard:** The inner courtyard is overgrown but it does include a functioning well.
- I. **The Great Temple:** The great temple is an octagonal temple made of human skulls mortared together. The temple is dedicated to the great demon-god of the ghouls, who lives in a pit in the centre of the temple. Each corner of the temple has a 20 foot tall spire of human skulls rising up in a grim display of their victories and slaughters.
- J. **The Purple Spire:** This purple spire was once the home of a great sorcerer; the ghouls fear this edifice and avoid it. The spire is 40 feet tall and has a bladed appearance.
- K. **The Topped Spire:** Similar to the Purple Spire, except this one has fallen over, crushing several buildings beneath its fallen mass.
- L. **The Outer City:** This is a maze-like warren of streets and ruined buildings. The western side is completely reduced to rubble however, due to an earthquake. Trees and underbrush poke through the streets and ruins.
- M. **Public Baths:** This is a massive edifice where the founders relaxed and enjoyed themselves at the expense of the slaves. Although the roofs have all caved in, the ghouls still use the now-gross pools and lavatories for their own mockeries of life as well as a hot-house for growing red lotus (see *Conan: Hyboria's Finest*).
- N. **Combat Arena:** This is the ruin of the old combat arena where ancient lords pitted their slaves against each other. Trials by combat also took place here. The ruin climbs up the walls of the overgrown motte. Three towers from the wall above overlook the arena, where the greatest of lords would watch the combat matches.
- O. **Harbour:** The harbour is a useless ruin – the wooden piers have long since rotted away, leaving stone pylons in the water.
- P. **Rock Cut Tombs:** Along the slopes of the mottes are entrances to deep, underground tombs of the most wealthy city inhabitants. The tombs have all been broken into by the ghouls, and they mostly live there now.

MAGIC & UNUSUAL ITEMS HIDDEN IN THE RUINS

There is treasure galore in the city of the ghouls, lost since the age of Acheron.

TRIREGNUM OF HIGH PRIEST SHRAYEENT

This triregnum, a jewelled three-tiered religious crown in the shape of a beehive, appears as three crowns stacked on top of each other. Two lappets hang from the back of the triregnum, stitched with arcane symbols and the House design of Pehzemeenyt, the family crest of Shrayeent the High Priest. The stitching on the lappets are of gold thread. The core of the triregnum is made of silver. The exterior is coated in gold leaf and beautiful diamonds.

Whenever a sorcerer wears the triregnum, the target(s) of any spell he casts must make a Fortitude save (DC set by the sorcerer's magic attack roll) or be knocked prone from the force of the casting. If the target rolls a natural 1 on the save, he is knocked back 5 feet in addition to falling prone.

The triregnum also feeds upon sorcerous success. If the sorcerer casts a spell that succeeds in all that it was intended, then he may cast the spell the following round with one element of the spell doubled (duration, damage, save DC, range, and so on), in addition to the regular benefits discussed in *Conan the Roleplaying Game* under The Rule of Success.

There is a legend associated with this triregnum: anyone who takes possession of the triregnum will come into a great fortune that will bring ruin and hardship to his family and friends.

Manufacturing Costs: 30,000 sp; 3,000 xp; caster level 12th; spells required: *greater demonic pact* or *master words and signs*

MONSTERS OF THE CITY OF GHOULS

Of course the City of Ghouls hosts large numbers of ghouls. The *Conan the Roleplaying Game* core rules provide statistics for commoner ghouls. This section provides statistics for ghouls who are a cut above the common and have taken character classes. 50% of all ghouls are the standard ghouls described in the core rules for *Conan the Roleplaying Game*. 25% are level 1 barbarians, 15% are level 2 barbarians, 4%

are level 3 barbarians, 3% are level 4 barbarians, 2% are level 5 barbarians and 1% are level 6 or higher barbarians or some other class of any level.

SAMPLE GHOULS

Barbarian 1: Medium Monstrous Humanoid; Hit Dice: 6d8+18 plus 1d10+3 (53 hp); **Initiative:** +11 (+2 Dex, +9 Reflex); **Speed:** 40 ft.; **Dodge Defence:** 16 (+2 Dex, +4 natural); **DR:** 2; **Base Attack/Grapple:** +7/+10; **Attack:** Claw +10 melee (1d4+3); **Full Attack:** 2 claws +10 melee (1d4+3), bite +8 melee (1d8+1, AP 4); **Space/Reach:** 5 ft. (1)/5 ft. (1); **Special Attacks:** Improved grab, relentless jaws, versatility (–2 penalty); **Special Qualities:** Fearless; **Saves:** Fort +9, Ref +9, Will +2; **Abilities:** Str 16, Dex 14, Con 14, Int 10, Wis 10, Cha 1; **Skills:** Climb +4, Hide +8, Intimidate –4, Listen +6, Move Silently +8, Spot +5, Survival +1; **Feats:** Improved Bull Rush, Multiattack, Power Attack, Toughness, Track; **Climate/Terrain:** Any land; **Organization:** Solitary, patrol (2-4), or gang (5-20); **Advancement:** By character class (favoured class: barbarian)

Barbarian 2: Medium Monstrous Humanoid; Hit Dice: 6d8+18 plus 2d10+6 (62 hp); **Initiative:** +12 (+2 Dex, +10 Reflex); **Speed:** 40 ft.; **Dodge Defence:** 17 (+2 Dex, +4 natural, +1 class); **DR:** 2; **Base Attack/Grapple:** +8/+11; **Attack:** Claw +11 melee (1d4+3); **Full Attack:** 2 claws +11 melee (1d4+3), bite +9 melee (1d8+1, AP 4); **Space/Reach:** 5 ft. (1)/5 ft. (1); **Special Attacks:** Crimson mist, improved grab, relentless jaws, versatility (–2 penalty); **Special Qualities:** Bite sword, fearless; **Saves:** Fort +10, Ref +10, Will +2; **Abilities:** Str 17, Dex 14, Con 14, Int 10, Wis 10, Cha 1; **Skills:** Climb +5, Hide +8, Intimidate –2, Listen +6, Move Silently +8, Spot +5, Survival +2; **Feats:** Improved Bull Rush, Multiattack, Power Attack, Toughness, Track; **Climate/Terrain:** Any land; **Organization:** Solitary, patrol (2-4), or gang (5-20); **Advancement:** By character class (favoured class: barbarian)

Barbarian 3: Medium Monstrous Humanoid; Hit Dice: 6d8+18 plus 3d10+9 (70 hp); **Initiative:** +12 (+2 Dex, +10 Reflex); **Speed:** 40 ft.; **Dodge Defence:** 18 (+2 Dex, +4 natural, +2 class); **DR:** 2; **Base Attack/Grapple:** +9/+12; **Attack:** Claw +12 melee (1d4+3); **Full Attack:** 2 claws +12 melee (1d4+3), bite +10 melee (1d8+1, AP 4); **Space/Reach:** 5 ft. (1)/5 ft. (1); **Special Attacks:** crimson mist, improved grab, relentless jaws, versatility (–2 penalty); **Special Qualities:** bite sword, fearless, trap sense +1; **Saves:** Fort +10, Ref +10, Will +3; **Abilities:** Str 17, Dex 14, Con 14, Int 10, Wis 10, Cha 1; **Skills:** Climb +5, Hide +8, Intimidate +2, Listen +6, Move Silently +8, Spot +5, Survival +2; **Feats:** Crushing Grip, Endurance, Improved Bull Rush, Multiattack, Power Attack, Toughness, Track; **Climate/Terrain:** Any land; **Organization:** Solitary, patrol (2-4), or gang (5-20); **Advancement:** By character class (favoured class: barbarian)



Dex, +4 natural, +3 class); **DR:** 2; **Base Attack/Grapple:** +11/+15; **Attack:** Claw +15 melee (1d4+4); **Full Attack:** 2 claws +15 melee (1d4+4), bite +13 melee (1d8+2, AP 5); **Space/Reach:** 5 ft. (1)/5 ft. (1); **Special Attacks:** Crimson mist, improved grab, relentless jaws, versatility (–2 penalty); **Special Qualities:** Bite sword, fearless, trap sense +1, uncanny dodge; **Saves:** Fort +11, Ref +11, Will +3; **Abilities:** Str 18, Dex 15, Con 15, Int 11, Wis 11, Cha 2; **Skills:** Climb +6, Hide +9, Intimidate +6, Listen +6, Move Silently +9, Spot +6, Survival +4; **Feats:** Crushing Grip, Endurance, Improved Bull Rush, Improved Overrun, Mobility, Multiattack, Power Attack, Toughness, Track; **Climate/Terrain:** Any land; **Organization:** Solitary, patrol (2-4), or gang (5-20); **Advancement:** By character class (favoured class: barbarian)

Barbarian 6: Medium Monstrous Humanoid; Hit Dice: 6d8+18 plus 4d10+12 plus 6 (85 hp); **Initiative:** +16 (+3 Dex, +13 Reflex); **Speed:** 40 ft.; **Dodge Defence:** 21 (+3 Dex, +4 natural, +4 class); **DR:** 2; **Base Attack/Grapple:** +12/+16; **Attack:** Claw +16 melee (1d4+4); **Full Attack:** 2 claws +16 melee (1d4+4), bite +14 melee (1d8+2, AP 5); **Space/Reach:** 5 ft. (1)/5 ft. (1); **Special Attacks:** Crimson

Barbarian 4: Medium Monstrous Humanoid; Hit Dice: 6d8+18 plus 4d10+12 (79 hp); **Initiative:** +13 (+2 Dex, +11 Reflex); **Speed:** 40 ft.; **Dodge Defence:** 19 (+2 Dex, +4 natural, +3 class); **DR:** 2; **Base Attack/Grapple:** +10/+14; **Attack:** Claw +14 melee (1d4+4); **Full Attack:** 2 claws +14 melee (1d4+4), bite +12 melee (1d8+2, AP 5); **Space/Reach:** 5 ft. (1)/5 ft. (1); **Special Attacks:** Crimson mist, improved grab, relentless jaws, versatility (–2 penalty); **Special Qualities:** Bite sword, fearless, trap sense +1, uncanny dodge; **Saves:** Fort +11, Ref +11, Will +3; **Abilities:** Str 18, Dex 15, Con 15, Int 11, Wis 11, Cha 2; **Skills:** Climb +6, Hide +8, Intimidate +6, Listen +6, Move Silently +8, Spot +5, Survival +3; **Feats:** Crushing Grip, Endurance, Improved Bull Rush, Multiattack, Power Attack, Toughness, Track; **Climate/Terrain:** Any land; **Organization:** Solitary, patrol (2-4), or gang (5-20); **Advancement:** By character class (favoured class: barbarian)

Barbarian 5: Medium Monstrous Humanoid; Hit Dice: 6d8+18 plus 4d10+12 plus 3 (82 hp); **Initiative:** +13 (+2 Dex, +11 Reflex); **Speed:** 40 ft.; **Dodge Defence:** 19 (+2

mist, improved grab, relentless jaws, versatility (–2 penalty); **Special Qualities:** Bite sword, fearless, trap sense +2, uncanny dodge; **Saves:** Fort +12, Ref +13, Will +4; **Abilities:** Str 18, Dex 16, Con 15, Int 11, Wis 11, Cha 2; **Skills:** Climb +7, Hide +10, Intimidate +6, Listen +7, Move Silently +10, Spot +7, Survival +5; **Feats:** Crushing Grip, Diehard, Endurance, Improved Bull Rush, Improved Overrun, Improved Sunder, Mobility, Multiattack, Power Attack, Toughness, Track; **Climate/Terrain:** Any land; **Organization:** Solitary, patrol (2-4), or gang (5-20); **Advancement:** By character class (favoured class: barbarian)

Ghouls are misshapen, grey humanoids of enormous strength and vitality who eat human flesh. It is whispered that the ghouls have a limited society of sorts, though travellers and scholars have never returned alive to confirm or deny these rumours.

Ghouls speak their own language of grunts, howls and screams. No non-ghoul has yet mastered it, largely due to the near-impossibility of dealing peacefully with these primal horrors.

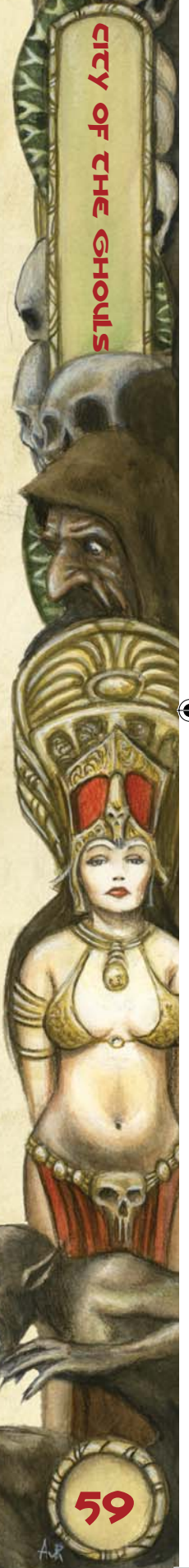

Combat

Ghouls usually attack in a wild frenzy of claws and teeth, though against a more powerful foe they will use more careful hit-and-run tactics.

Improved Grab (Ex): To use this ability, the ghoul must hit with a bite. If it gets a hold, it can use its Relentless Jaws attack the following round.

Relentless Jaws (Ex): Once a ghoul has hold of an opponent in its jaws (see Improved Grab, above) it can continue biting him each round thereafter, dealing standard bite damage. This also gradually chews through its opponent's armour – each round the ghoul uses Relentless Jaws, including the first round, the AP rating of its bite increases by +1.

Skills: Ghouls have a +2 racial bonus to their Hide and Move Silently skills.

KING OF THE GHOULS

Barbarian 6/Thief 1/Noble 1

Medium Monstrous Humanoid

Hit Dice: 6d8+30 plus 4d10+20 plus 6 plus 2 plus 2 (109 hp)

Initiative: +20 (+4 Dex, +16 Reflex)

Speed: 40 ft. (8 squares)

Dodge Defence: 22 (+4 Dex, +4 natural, +4 class)

DR: 2

Base Attack/Grapple: +12/+18

Attack: Claw +18 melee (1d4+6)

Full Attack: 2 claws +18 melee (1d4+6), bite +16 melee (1d8+3, AP 7)

Space/Reach: 5 ft. (1)/5 ft. (1)

Special Attacks: Crimson mist, improved grab, relentless jaws, sneak attack +1d8/+1d6, sneak attack style (bite), versatility (–2 penalty)

Special Qualities: Bite sword, fearless, rank hath its privileges, title, trap disarming, trap sense +1, uncanny dodge, wealth

Saves: Fort +14, Ref +16, Will +7

Abilities: Str 23, Dex 19, Con 18, Int 10, Wis 12, Cha 7

Skills: Balance +5, Bluff +2, Climb +7, Hide +14, Intimidate +10, Listen +6, Move Silently +14, Sense Motive +4, Spot +6, Survival +4, Tumble +5

Feats: Crushing Grip, Endurance, Improved Bull Rush, Improved Sunder, Mobility, Multiattack, Power Attack, Stunning Attack, Toughness, Track

Climate/Terrain: Any land

Organization: Solitary, patrol (2-4), or gang (5-20)

Advancement: By character class (favoured class: barbarian)

The horrible king of the ghouls is a physically powerful ghoul with the support of the shaman.

He only gains the noble class abilities while within the City of the Ghouls. His wealth is measured in treasure and in flesh. The ghouls feed him



portions of their catches, as is his right as king. He does not actually have the loyalty of any of the ghouls – they obey him because he has the strength to make them obey. He lusts after human females, so occasionally a girl captured by a ghoul is not immediately eaten but brought to the king to be his queen until she dies from terror and anguish, often an event that happens long after madness sets in.

Combat

Ghouls usually attack in a wild frenzy of claws and teeth, though against a more powerful foe they will use more careful hit-and-run tactics. The king of the ghouls has also learned to hit his foes so hard they are often stunned. He also keeps red lotus residue under his long, gross fingernails (see *Conan: Hyboria's Finest* for the effects of red lotus residue).

Improved Grab (Ex): To use this ability, the ghoul must hit with a bite. If it gets a hold, it can use its Relentless Jaws attack the following round.

Relentless Jaws (Ex): Once a ghoul has hold of an opponent in its jaws (see Improved Grab, above) it can continue biting him each round thereafter, dealing standard bite damage. This also gradually chews through its opponent's armour – each round the ghoul uses Relentless Jaws, including the first round, the AP rating of its bite increases by +1.

Skills: Ghouls have a +2 racial bonus to their Hide and Move Silently skills.

GHOUL SHAMAN

Barbarian 3/Scholar 4

Medium Monstrous Humanoid

Hit Dice: 6d8+12 plus 3d10+6 plus 1d6+2 plus 3 (60 hp)

Initiative: +15 (+3 Dex, +12 Reflex)

Speed: 40 ft. (8 squares)

Dodge Defence: 20 (+3 Dex, +4 natural, +3 class)

DR: 2

Base Attack/Grapple: +12/+15

Attack: Claw +15 melee (1d4+3)

Full Attack: 2 claws +15 melee (1d4+3), bite +13 melee (1d8+1, AP 4)

Space/Reach: 5 ft. (1)/5 ft. (1)

Special Attacks: Crimson mist, improved grab, relentless jaws, sorcery, versatility (–2 penalty)

Special Qualities: +1 Power Point, acolyte background, advanced spell x2, base Power Points, bonus spell, bite sword, fearless, knowledge is power, new sorcery style x3, scholar, trap sense +1

Saves: Fort +10, Ref +12, Will +8

Abilities: Str 17, Dex 17, Con 13, Int 15, Wis 13, Cha 8

Skills: Bluff +6, Climb +6, Craft (sculpture) +18, Craft (herbalism) +5, Hide +10, Intimidate +9, Knowledge (arcana) +11, Knowledge (nature) +5, Knowledge (local) +6, Listen +4, Move Silently +14, Perform (ritual) +10, Sense Motive +4, Spot +5, Survival +4

Feats: Crushing Grip, Endurance, Focused Magical Link, Hexer, Multiattack, Ritual Sacrifice, Toughness, Track

Power Points: 6 (4 base, +1 Wis, +1 bonus; 12 maximum)

Magical Attack Bonus: +2/+4 (+3 base, –1 Cha; +2 bonus if casting a curse)

Sorcery Styles Known: Divination, Curses, Summonings

Spells Known: *Astrological prediction, demonic pact, greater ill-fortune, ill-fortune, lesser ill-fortune, visions*

Climate/Terrain: Any land

Organization: Solitary, patrol (2-4), or gang (5-20)

Advancement: By character class (favoured class: barbarian)

The shaman of the ghouls uses the king to give him muscle and he supplies solid thinking and wisdom to the king in return. Although the two do not necessarily like each other, they recognise the other as an important half of a ruling whole. If the games master desires, he may possess the Tireregnum of High Priest Shrayeent (see page 58).

The shaman likes to make fetish dolls, and has one made up for almost any ghoul of importance. His lair is lined with hundreds of these fetish dolls as he is a firm believer in the power of vengeance. He longs to unlock the mysteries of alchemy, which has been told to him by his father (who was shaman before him), but he does not know where to even begin his studies.

He has a *demonic pact* with the demon-god of the ghouls, Quf-jushke'een. He dresses in an outfit of feathers, bones,

skulls and animal pelts and he usually wears greaves that he took from a tomb.

Combat

Ghouls usually attack in a wild frenzy of claws and teeth, though the shaman of the ghouls prefers to stay out of the fighting. He sends his acolytes (2 regular ghouls) to bring him back trophies of intruders so he can fashion fetish-dolls to increase his magic against them.

Improved Grab (Ex): To use this ability, the ghoul must hit with a bite. If it gets a hold, it can use its Relentless Jaws attack the following round.

Relentless Jaws (Ex): Once a ghoul has hold of an opponent in its jaws (see Improved Grab, above) it can continue biting him each round thereafter, dealing standard bite damage. This also gradually chews through its opponent's armour – each round the ghoul uses Relentless Jaws, including the first round, the AP rating of its bite increases by +1.

Skills: Ghouls have a +2 racial bonus to their Hide and Move Silently skills.

THE DEMON-GOD OF THE GHOULS

Huge Outsider (demon)

Hit Dice: 20d8+300 (390 hp)

Initiative: +4 (–4 Dex, +8 Reflex)

Speed: 10 ft. (2 squares)

Dodge Defence: 19 (–2 Size, –4 Dex, +15 natural)

DR: 4

Base Attack/Grapple: +20/+43

Attack: Tentacle +33 (2d6+15)

Full Attack: 8 tentacles +33 (2d6+15, 19-20, x2, AP 20), bite +28 (2d8+15, 19-20, x2, AP 22)

Space/Reach: 15 ft. (3)/15 ft. (3)

Special Attacks: Constrict, improved grab, *summon demon*, swallow whole, tongue attack (+33 melee)

Special Qualities: Manifest

Power Points: 55 (base 50, +5 Wis)

Magic Attack Bonus: +15 (+10 natural, +5 Charisma)

Saves: Fort +27, Ref +8, Will +17

Abilities: Str 40, Dex 2, Con 40, Int 18, Wis 20, Cha 20

Skills: Balance +29, Climb +38, Craft (alchemy) +27, Craft (herbalism) +27, Intimidate +28, Jump +38, Knowledge (arcana) +27, Knowledge (religion) +27, Listen +28, Perform (ritual) +28, Spot +28

Feats: Power Attack, Cleave, Great Cleave, Improved Critical (tentacle), Improved Critical (bite), Improved Bull Rush, Improved Overrun

Environment: Any land and underground

Organisation: Solitary

Advancement: –



Known among the ghouls as Quf-jushke'een, the demon-god of the ghouls is enormous, some 18 feet tall. He resembles a grossly fat toad, horned and fanged, with eight black tentacles instead of forelegs and six glowing red eyes all in a horrible row. His bulk is such that his back legs cannot move him without the aid of at least six of the eight tentacles (he can only attack with two tentacles if he makes a five foot step).

He is the patron of the ghouls' shaman and has promised to teach alchemy if he will provide him with a virgin princess. So far the shaman has been unable to provide this princess. The last one captured by the ghouls was promptly made into another of the Ghoule King's brides and was soon afterward no longer met the demon's demands.

The demon-god of the ghouls is a typical demon lord of the type which humans may make pacts with. He is even quite willing to dwell upon Earth if this is requested of him, so long as he is well supplied with sacrifices. As with any demon lord, he can teach a mortal any spells he wishes, though the demon-god of the ghouls himself is not very effective when it comes to casting magic.

Combat

The demon-god of the ghouls' combat style is simple and brutal. He will simply wobble over to his enemies, rip them apart with his tentacles and fangs, and devour them.

Manifest (Su): As a full-round action, The demon-god of the ghouls can either leave Earth and return to his home place, or appear somewhere on Earth. In either case, he manifests at the new location at the end of his action.

Improved Grab (Ex): The demon deals normal damage and attempts to start a grapple as a free action without provoking an attack of opportunity. To use this ability, the demon must hit with a tentacle, tongue or a bite. If it gets a hold, it can use its constrict attack the same round. When a creature gets a hold after an improved grab attack, it pulls the opponent into its space. If it attacks with its bite or tongue for the grab, it can swallow whole.

Constrict (Ex): Quf-jushke'een can crush an opponent, dealing bludgeoning damage, after making a successful grapple check. It deals constriction damage in addition to damage dealt by the tentacle used to grab.

Swallow Whole (Ex): If the demon begins its turn with an opponent held in its mouth (see Improved Grab), it can attempt a new grapple check (as though attempting to pin the opponent). If it succeeds, it swallows its prey, and the opponent takes bite damage. Unless otherwise noted, the opponent can be up to one size category smaller than the swallowing creature. A swallowed creature is considered to be grappled, while the creature that did the swallowing is not. A swallowed creature can try to cut its way free with any light slashing or piercing weapon (the amount of cutting damage required to get free is noted in the creature description), or it can just try to escape the grapple. The Defence of the demon from the inside is 17. If the swallowed creature escapes the grapple, success puts it back in the demon's mouth, where it may be bitten or swallowed again.

Tongue Attack (Ex): Quf-jushke'een can attack anyone within his reach with his tongue. It is sticky and, if it strikes a person, starts a grapple as a free action. If it attacks with its tongue, it may not attack with a bite the same round. Anyone grappled by the tongue is pulled into its mouth and it may swallow most prey whole the following round.

Slime (Sp): Quf-jushke'een's back produces a greasy, black slime. If taken orally or smeared on the body, it acts as a drug, providing a sexual high. Characters in contact with the slime must make a Fortitude saving throw (DC 25) or be unable to take any non-sexual actions for 1d4 hours. Anyone under the influence of his slime is considered entranced for the purposes of other spells.

Summon Demon (Sp): Quf-jushke'een can cast summon demon in lieu of making melee attacks, although he can only summon Servitors of Quf-jushke'een.

SERVITORS OF QUF-JUSHKE'EEN

Medium Outsider (demon)

Hit Dice: 9d8+27 (67 hp)

Initiative: +6 (+6 Reflex)

Speed: 20 ft. (legs) or 40 ft. (tentacles)

Dodge Defence: 17 (+6 natural, +1 dodge)

Damage Reduction: 4

Base Attack/Grapple: +9/+15

Attack: Tentacle +16 melee finesse (1d8+6)

Full Attack: 8 tentacles +16 melee finesse (1d8+6) and Bite +12 melee finesse (1d6+6)

Space/Reach: 5 ft. (1)/5 ft. (1)

Special Attack: Constrict, improved grab, slime

Special Qualities: Manifest

Power Points: 13 (base 10, +3 Wis)

Magic Attack Bonus: +8 (+4 natural, +4 Charisma)

Saves: Fort +9, Ref +6, Will +9

Abilities: Str 23, Dex 10, Con 17, Int 12, Wis 17, Cha 19

Skills: Craft (herbalism) +13, Heal +6, Hide +12, Jump +18, Knowledge (arcana) +13, Move Silently +12, Perform (dance) +10, Sense Motive +6

Feats: Blindfight, Dodge, Multiattack, Weapon Focus (tentacle)

Climate/Terrain: Any land and underground

Organization: Solitary

Advancement: By character class (usually scholar or barbarian)

They appear similar to Quf-jushke'een but they are bipedal and not so large. The Servitors of Quf-jushke'een resemble toads, horned and fanged, with eight black tentacles instead of forelegs and six glowing red eyes all in a horrible row. They walk upright on their toad-like hind legs although they can use their tentacles for faster locomotion (this may limit their attacks in a full-attack action) by walking on the tentacles instead of their legs. These horrid abominations are driven solely by lust. They eat human flesh or their own fallen dead.

Combat

A Servitor of Quf-jushke'een combat style is simple and brutal. He will simply wobble or jump over to his enemies, rip them apart with his tentacles and fangs, and devour them as they fall.

Manifest (Su): As a full-round action, the Servitors of Quf-jushke'een can either leave Earth and return to their home place, or appear somewhere on Earth. In either case, they manifest at the new location at the end of his action.

Improved Grab (Ex): A Servitor of Quf-jushke'een deals normal damage and attempts to start a grapple as a free action without provoking an attack of opportunity. To use this ability, the demon must hit with a tentacle, tongue or a bite. If it gets a hold, it can use its constriction attack the same round. When a creature gets a hold after an improved grab attack, it pulls the opponent into its space.

Constrict (Ex): A Servitor of Quf-jushke'een can crush an opponent, dealing bludgeoning damage, after making a successful grapple check. It deals constrict damage in addition to damage dealt by the tentacle used to grab.

Slime (Sp): A Servitor of Quf-jushke'een's back produces a greasy, black slime. If taken orally or smeared on the body, it acts as a drug, providing a sexual high. Characters in contact with the slime must make a Fortitude saving throw (DC 13) or be unable to take any non-sexual actions for 1d4 hours. Anyone under the influence of his slime is considered entranced for the purposes of other spells.

Dagoth Hill

PRE-HUMAN DEMON-HAUNTED RUIN

THE DEMON-HAUNTED location known as Dagoth Hill is the site of pre-human ruins. Some sources indicate the ruins are in Koth, other sources place it near Shadizar. The Games Master can place it where he wishes.

HISTORY

The ruins on Dagoth Hill were ancient even during the days of Valusia. These ruins formed a megalithic funerary site. Its inhabitants lived around the hill (or some theorise beneath it) in wooden structures and may have retreated into the dark citadel during conflicts.

LAYOUT

Dagoth Hill is a steep and wide hill rising out of the surrounding plain. The immense ruins on top of the hill stand out for miles around and are steeped in local folklore and the site for many horrific tales.

The pre-human ruins on Dagoth Hill are built out of cyclopean blocks of immense stone, 15 feet wide, 15 feet tall and 30 feet long. The blocks of stone are heavily weathered, so the edges are rounded and any carvings they might have once had on them have long since been blasted off. The stones do not have battlements of any kind. One section of the wall is heavily crumbled and reduced largely to rubble for most of its length. Whether these massive stones were reduced to rubble by weather or by war or by magic is subject to heavy speculation. Perhaps only the demons of the Hill know the truth.

THE TRILITHON GATEWAYS

There are three official openings into the ruin. The gates are trilithons held together by mortise and tenon joints. Two of the 15 x 15 x 30 foot stones are set up on end and hold up a 15 x 15 x 60 foot megalith.

Gate 1: The northernmost gate leads into a thirty-foot wide, roofless hallway approximately 270 feet long called the Hall of the Dead. This passage curves along until it reaches an irregular courtyard and a stone tunnel/building.

Gates 2 & 3: Two of the gates lead into a large, mostly-empty courtyard of burial mounds and cairns. A few blocks of stone sit in this courtyard but no one knows if those stones belong there or were somehow moved from one of the walls to their current position. Certainly no one in the Hyborian Age has the means to move such massive stones easily.

THE HALL OF THE DEAD

Entered by the northernmost trilithon gateway structure, the hall of the dead is believed to be a funerary passage with a ritual purpose. This passage represented the path from the world of the living to the world of the dead. It is possible there used to be smaller but similar halls leading from the other two gates. The passage is approximately 270 feet long and is bounded by seventeen 30 feet long, 15 feet high, 15 feet wide blocks of stone and one block of 30 feet high, 30 feet long, 15 feet wide stone on the southern side. The hall of the dead leads to Courtyard 1. The hall was once paved, but time has reduced most of the paving stones to gravel and tall, dry grasses grow throughout the hall.

COURTYARD 1

This courtyard, was once partially paved. Scholars believe the southwest corner, next to the thirty foot tall stone, once had a well that was filled in with rubble and dirt during Valusian times. Long rituals are believed to have taken place here when the funeral procession reached this point. Building 1 juts into this courtyard.

BUILDING 1

This building is little more than a tall tunnel connecting Courtyard 1 with Courtyard 2. It was built by stacking three 60 foot long, 15-foot wide and 15-foot tall stones on top of each other with mortise and tenon joints. No one really knows what this structure was used for or why it was built so tall. The amount of effort needed to hoist those four 600 ton rocks 45 feet into the air is staggering.

COURTYARD 2

Courtyard 2 is the courtyard in front of the impressive Building 2. Ancient pathstones lead in three directions: toward Courtyard 3, toward Building 2; and toward Courtyard 4. Tall, dry grasses grow here and a few spindly

DAGOTH HILL RUINS

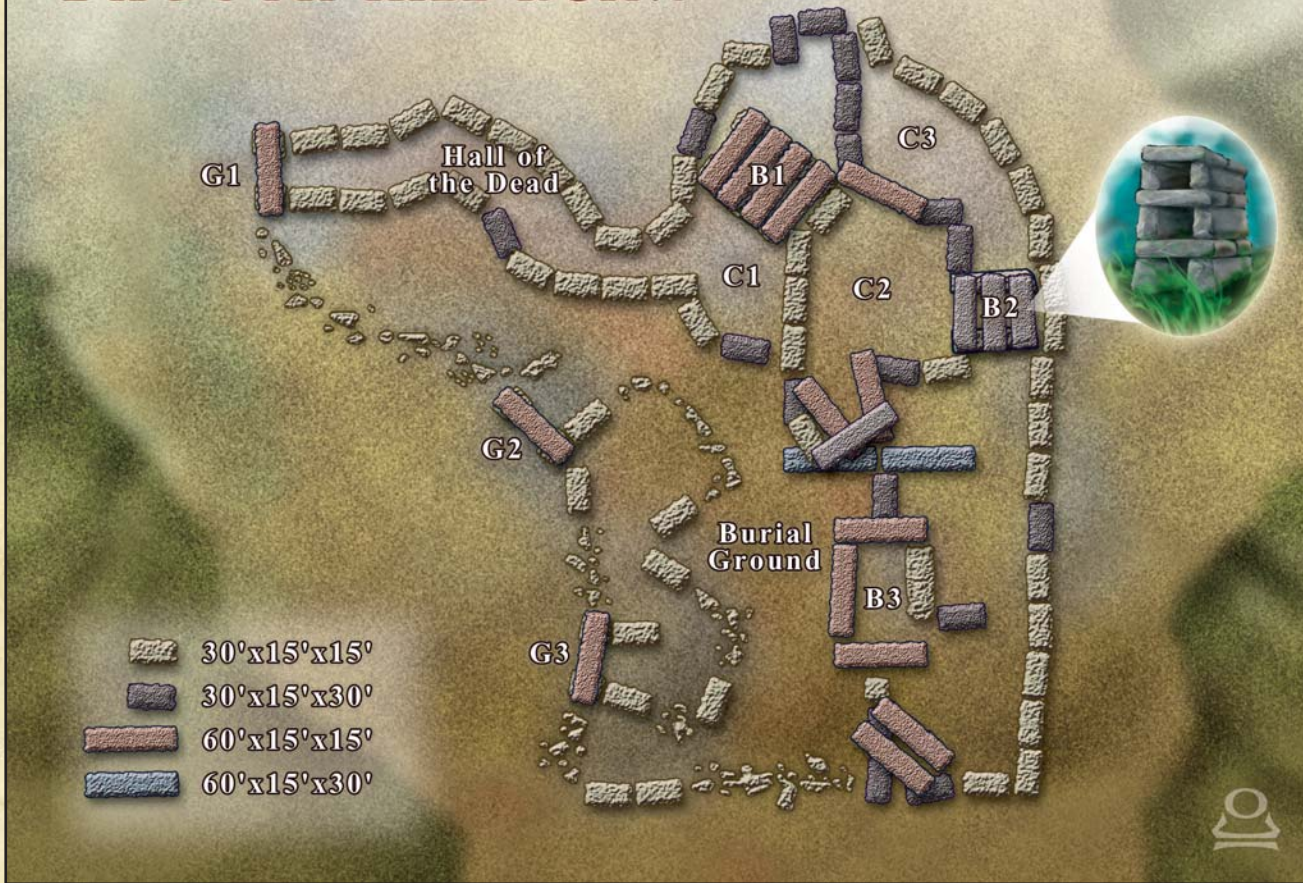

DAGOTH HILL

trees have taken root. Funerary objects and ritual items can often be found in the grasses or beneath a small layer of soil indicating that this courtyard may also have been the scene of some inhuman ceremony for the funeral. A 300-year old Nemedian scroll indicates an altar used to be situated in front of Building 2 and was the scene of mass sacrifices in honour of the deceased. The same scroll claims the altar was moved from the ruins to Edram castle.

BUILDING 2

This impressive building is a hundred feet tall. It has three storeys (or at least three chambers); however, there is no intrinsic way to reach the upper levels. There are no stairs, no carven handholds, no trapdoors and no place to hang a rope. The chambers are open in the front (the west-facing side) and closed in the back by a 15-foot thick back wall (the east-facing side). There are no windows. Each floor is also fifteen feet thick, as are the walls and the roof. The chambers are thirty feet wide and sixty feet long. Nothing grows inside and there is nothing to see. If there were furnishings, they have long since vanished.

There are cave-style paintings on the interior, but no one knows if these were painted by the inhuman creators of the ruin or placed there by later dwellers. The drawings create an Element of Horror in anyone who sees them, as well as an Element of Madness (see page 23). The time it takes for the madness to evolve is a number of minutes equal to half of the character's Wisdom score, spent in front of the drawings (characters may also accept a point of Corruption in lieu of going mad if the saving throw fails).

Those who can decipher the script (DC 55) must make an additional batch of saves (horror, then madness) as well as a Corruption save. If deciphered the character understands some horrible truths about reality and gains a Fate Point (he knows a little bit about how to adjust his own reality), and he understands something about sorcery: the character becomes particularly effective with spells of the Summoning sorcery style. Whenever he casts a *summon demon* or *summon elemental* spell, his scholar class level is considered to be +2 for purposes of both the maximum HD that can be summoned and the duration of the spell. Further, the translator of the ruins can choose to make scholar his favoured class, regardless of race.



COURTYARD 3

Courtyard 3 is entered by walking beneath another trilithon entry 50 feet wide and 15 feet deep along the northern wall of courtyard 2. This courtyard is filled with ancient cairns.

COURTYARD 4

Courtyard 4 is entered by walking beneath an irregular stone-bounded entry on the south-eastern corner of Courtyard 2. This weed-choked courtyard is fairly flat and leads to Building 3. The south-western corner of this courtyard has long roof-stones set on top of the fifteen-foot tall wall. Most of the walls surrounding this courtyard are 15 feet tall, except for one stone on the eastern wall, a stone on the western wall and a stone in front of Building 3; these stones are 30 feet tall.

BUILDING 3

Building 3 is not a roofed structure. It is built from four 15-foot tall, 60 foot long stones. It is entered through a 2 foot wide crevice between the building stones. This area is filled with charcoal, bones and dirt and it was where pyres were built and set ablaze. Considering the race seems to have buried its dead, no one has decided what purpose the burning was for. Some scholars speculate that it was later squatters that used it as a place of cremation. Others believe the pyres were ceremonial in some manner to the pre-human race.

BURIAL GROUND

The area labelled as the Burial Ground is a huge courtyard on the western edge of the ruin. It is filled with low mounds and rocky cairns.

LEGENDS

Tsotha-lanti (of Robert E. Howard's *The Scarlet Citadel*) was conceived in or near the Dagooth Hill ruins.

Anyone who sleeps near the Dagooth Hill ruins risks being raped, attacked or seduced by demons. The spawn of such unholy unions take the *Spawn of Dagooth Hill* template (see *Conan the Roleplaying Game*).

There used to be an altar in front of Building 2 and ancient records indicate it was taken to Edram castle. When the owner died of spontaneous combustion, the altar was sold to a collector in Hanumar, who intended to smash the altar in front of a mitraeum in a ritualised display of Mitran power. The day before the ceremony all the

As for Tsotha - men say that a dancing-girl of Shadizar slept too near the pre-human ruins on Dagooth Hill and woke in the grip of a black demon: from that unholy union was spawned an accursed hybrid men call Tsotha-lanti -

Robert E. Howard, *The Scarlet Citadel*

members of that particular mitraeum died of various causes. For over 250 years, the altar moved around Nemedra (and one excursion into Ophir), bought by collectors to be sold by those collectors' heirs when the various purchasers died uncanny deaths. At one point it was listed in the inventory of a certain museum in Numalia but after its owner died a strange death it was sold again without known record. It is said that if the altar should be returned to the ruins of Dagooth Hill a demon from the deepest pits of Hell will reward the rescuer with wealth unimaginable.

MONSTERS OF DAGOOTH HILL

Demons and fiends of all sort still wander the ruins on Dagooth Hill at night. The Games Master can use any sort of demon or fiend desired or create a unique one for the purpose of an adventure in the ruins. Black Fiends (see *Conan the Roleplaying Game*) are especially appropriate.



Green Stone Cities

STRANGE RUINS OF AN UNKNOWN CULTURE

THE ROBERT E. HOWARD short stories of *Iron Shadows in the Moon*, *Xuthal of the Dusk*, *The Devil in Iron*, *The Pool of the Black One* and *Drums of Tombalku* all feature ruins made of green stone. This chapter will notate certain aspects common to all the green-stone cities so the Games Master can create his own and still have them mesh well with Howard's writings if desired. Following are descriptions of Gazal, the Isle of Iron Statues, the Isle of the Black Ones and Xuchotl.

HISTORY

This history draws heavily upon the conclusions of Dale E. Rippke in his article, *The Mystery of the Green Stone Cities (The Hyborian Heresies)*. Although little is known of the culture or cultures that built the green stone cities, in all likelihood the culture originated in the east. Dale Rippke hypothesises they are Lemurians of the East (see below).

They built their jade-green cities to honour the sea-god they worshipped. During the age of King Kull, they built their first cities on the Thurian continent. The Great Cataclysm destroyed most of Lemuria and Mu, crushing most of the green-stone cities. The religion of the sea-god fell away to be replaced by demon worship, such as Xultha the Ape-God. For 500 years, this strange culture tried to re-establish itself and even had commercial ties with the Giant-Kings.

The lesser cataclysm drowned many of these cities when the Vilayet sea formed. The culture gave way to nomadism as the climate changed around them. Many of the nomadic tribes of this ancient culture wandered eastward and became the Old Kosalans mentioned in *Red Nails*. Other tribes went south and founded cities such as Xuthal and Gazal.

Later, the Old Kosalans were driven out of their homeland. Heading westward, they would go on to found the city that would become known as Xuchotl.

LAYOUT OF GREEN STONE CITIES

The cities are generally built underneath a roof, resembling a massive palace. In the centre of the cities is a tower or temple and most of the roads converge upon this central edifice.

Most green-stone cities are octagonal but some variations exist, such as Xuchotl's oval shape. Of course, the cities are built out of green stone, either translucent or dark-coloured. The stone is either created magically or through some sort of science unknown even in the modern era. A generic green-stone city map is provided for the Games-Master's use. He may modify it to suit his needs, make part of it in ruins and leave other parts intact. Also he may people it with any sort of creatures and persons needed to tell his story or do whatever else he wishes.

GREEN STONE CHARACTERISTICS

Green stone has a typical break DC of 40, hardness 9, and a 10 x 10 section 1 foot thick has 150 hit points.

DEMON IN THE HEART

Almost all of the ancient green stone cities are built around a demon-god. Their religion centred around the worship of a demon from the outer dark, which was usually summoned forth to live in the temple of the city. The Xuthallans worshipped Thog, the people of Dagon worshipped Khosatral Khel, the people of the ruin of Gazal worshipped Ollam-onga and the citadel on the Isle of the Black Ones included a demonic being at its heart as well. However, an adventure involving a green-stone city does not have to include the central demon. Conan's adventure on the Isle of Iron Statues did not involve one, although it is likely the city at its prime had a demon-god, nor did his adventures in Xuchotl involve a demonic god – and it is possible that city did not have a central demon-god. Demons sometimes leave when there are no more worshippers, or they may linger behind, waiting with immortal anger at being abandoned.

NATURAL OR SUPERNATURAL DEFENCE

Like most ruins of the Hyborian Age, green stone cities have some sort of protective mechanism. They are either hard to reach or actually have some sort of supernatural/

GREEN STONE CITIES

GREEN STONE CITY

Covered with roof, including Central Pit/Dome/Tower

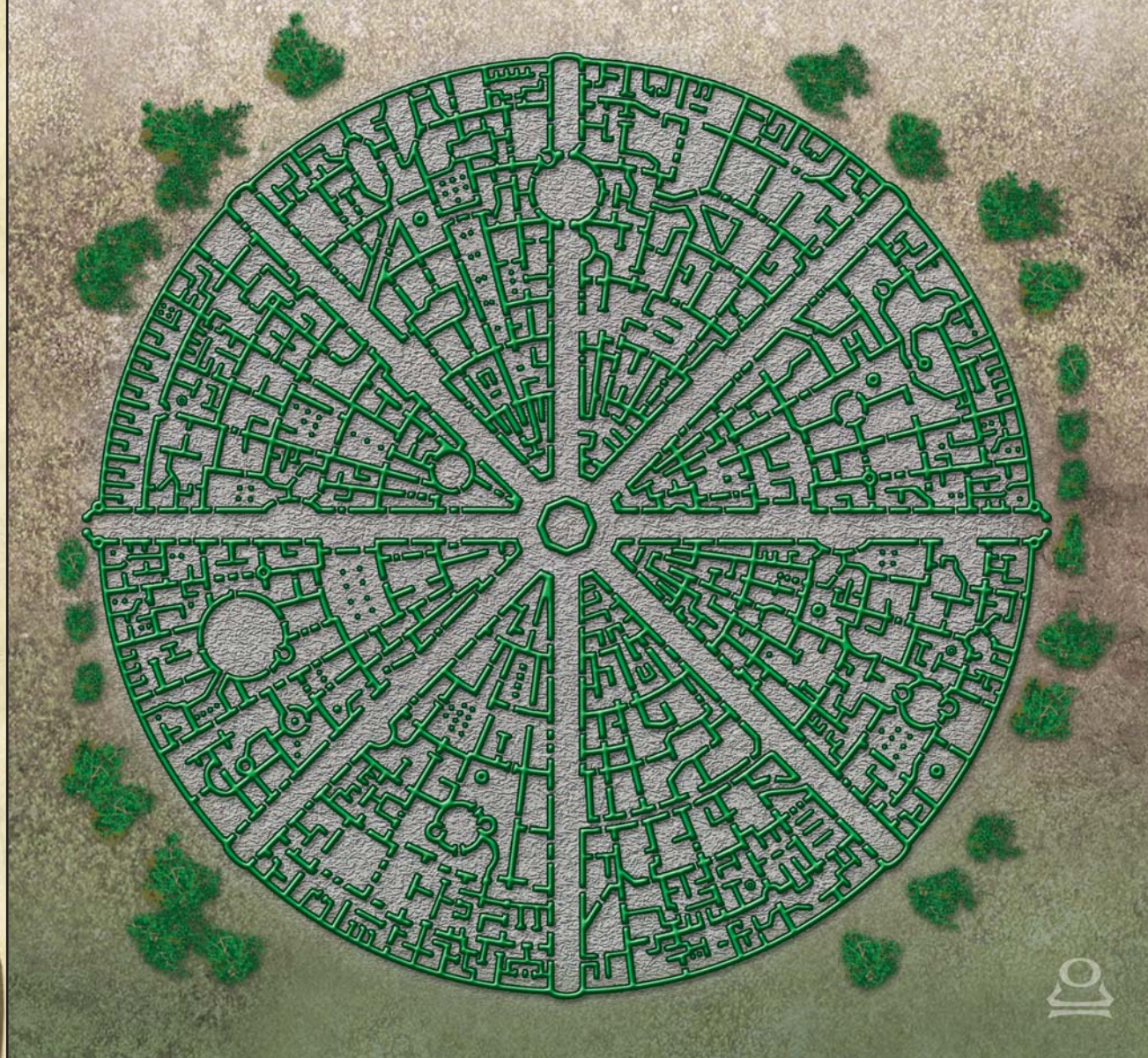

monstrous defence. In the case of Xuchotl, for example, the city was protected by a resurrected dragon as well as being in a less-than-well-travelled locale. A man-ape lived on the Isle of Iron Statues (not to mention the iron statues themselves) and Thog and Khosatral Khel still lurked about their ruins.

Most green-stone ruins have some protective mechanism generally falling into one of these types:

1. The green-stone ruin's flora has a soporific effect on those who pass beneath or ingest it. The target must make a Fortitude save (DC 20) or fall into slumber for 2d4 hours. During this time the affected character may have visions of the past or the future. The green-stone

ruin's intelligence will act against all affected characters, executing diabolical plans that usually involve some grisly sacrifice.

2. The green-stone ruins themselves are particularly decayed. Every 10 minutes (real time) characters moving around in them must make a Reflex save (DC 10) or take 1d4 blunt damage from falling debris. If the character rolls a natural 1 he takes damage and twists his ankle, reducing his movement speed by 10 ft. per round until someone takes the time to make a Heal check (DC 15).
3. The green-stone ruins contain some inexplicable element of horror. Those who look upon them must make a Terror check (DC 15). Characters that succeed do not need to make the check again. Characters that fail receive a -2 penalty on attack rolls, saving throws, skill checks, and ability checks, and flees from the area as quickly as possible. If the area has an active horrific effect (i.e. it restores itself to its former grandeur during the night hours) then characters that formerly succeeded must make a second Terror check. This effect remains until the character leaves the green-stone ruin for at least 24 hours.

Each of these base types may have any number of variations. For example, what if the decayed ruins were covered with a moss that causes hallucinations when it gets into wounds? What about an ancient, horrible ruin that causes people to act to rebuild it when they fail their Will saving throws? Such variations add interest and danger to what would otherwise be very repetitive experiences.

ADVANCED TECHNOLOGIES

Almost all green-stone cities have some form of advanced technology/sorcery/alchemy involved. Few bother with agriculture and grow their food from the air and/or elements; this may be accomplished through sorcery (see *fruit of air* in *Conan: The Scrolls of Skelos*), alchemy or underground machinery. Most have artificial light. Xuthal has radium gems (see *Conan: The Scrolls of Skelos*), Xuchotl has glowing green gems and Gazal has glowing globes as sources of artificial light.

GREAT WEALTH

Most green-stone cities still have great wealth or magical artefacts contained within.

NEW RACE LEMURIANS OF THE EAST

The people of this culture had saffron-coloured skin. Their eyes have an epicanthic fold. They are geniuses of the age, having mastered the use of both science and magic.

Culture: The culture of the Lemurians of the East is one of indolence and sorcery. They know little of cultivation or craft but they possess a great knowledge of curious architecture. What tools they do make are made of polished obsidian, jade or argillite. They create food out of the elements, growing them out of the air. They also make cities out of green stone, although no one knows if this is done through super-science or sorcery.

Names: No personal names of Lemurians are recorded. Names of gods and place-names tend to include an 'x' character, so it is possible that personal names are similar.

Religion: The Lemurians of the East are devil-worshippers for the most part (at least they gain their sorcerous knowledge from demons), but their utmost deity is an ancient god named Xultha the Apeman, the First God, a rival to Poseidon.

- ☼☼ +2 racial bonus to all Craft (alchemy), Craft (herbalism) and Knowledge (arcana) checks. Lemurians of the east are the inheritors of a grand and wondrous science that is beyond the ken of any other civilisation of the Hyborian Age. Though the Lemurians of the east still alive today remember little of how this advanced technology works, such knowledge nevertheless makes them the greatest scientists of the age.
- ☼☼ +1 racial bonus to all Fortitude saving throws against poisons, except black lotus blossom (which they always fail) and black lotus juice (which they receive a +4 bonus against).
- ☼☼ -2 racial penalty to any Craft skills other than alchemy or herbalism. The Lemurians of the east know little of such matters.

Background Skills: Craft (alchemy), Craft (herbalism), Knowledge (arcana) and Perform (ritual).

Favoured Class: Noble or Scholar.

Prohibited Classes: Barbarian, Borderer, Nomad and Pirate.

Automatic Languages: Ancient Lemurian.

Bonus Languages: None usable today.

Gazal

HORROR DWELLS IN THE RED TOWER

GAZAL IS A city deep in the desert, unknown to most Hyborian Age map-makers. Gazal appears in an unfinished Robert E. Howard story commonly known as *Drums of Tombalku*.

HISTORY

Many thousands of years ago, the culture that built the green-stone cities built one south of the lands of the Giant-Kings, a city centred around a red tower wherein they housed their demonic god, Ollam-Onga. For unknown reasons, the culture either abandoned the city or was exterminated as the city was already in ruins by the time Gazal was built.

Over 900 years ago the Gazali dwelt in southern Koth. The Gazali were noted for their scholarly wisdom but they were forced to leave Koth when they tried to revive the worship of Mitra, a religion the Kothians had long-since abandoned. The Gazali (comprised of priests, scholars, teachers and scientists) travelled south with their Shemitish slaves, through Shem and Stygia, into the Black Kingdoms. Lost in the desert, they built Gazal over a series of springs, an oasis in the desert. A green-stone ruin already occupied the site, so the Gazali used the green stones to build Gazal. The red stone tower was already on the location and the Gazali learned quickly to avoid the tower.

Once the city was built, the slaves revolted and fled into the desert to mix with the tribes they found there; they took every mount and pack animal with them. The Gazali learned to manufacture their food and drink from materials at hand.

LAYOUT

The city of Gazal is built of leaning spires, broken towers, sagging roofs and crumbling minarets of jade-green. A fragmented green wall rises sheer out of the desert sands. In the south-eastern corner of the city a shining red cylindrical tower rises high, shining amid the green ruins. The people of Gazal do not look toward this tower and try not to think about it. The streets are not straight and many buildings and courtyards cut into what would otherwise be straight paths to the Red Tower and *the house of the god*.

THE HOUSE OF THE GOD

Nearest the tower the ruins are savagely decayed, a heap of broken green masonry that reels and tumbles. Inside that dark mass are hung strange, sinister tapestries.

These inner ruins are particularly decayed. Moving around here is dangerous; every ten minutes spent moving around in these areas must make a Reflex save (DC 10) or take 1d4 blunt damage from falling debris. If the character rolls a natural 1 he takes damage and twists his ankle, reducing his movement speed by ten feet per round until someone takes the time to make a Heal check (DC 15).

MAGIC & UNUSUAL ITEMS KNOWN TO BE IN GAZAL

There are unknown secrets and monstrous things lurking in Gazal. Whole chambers in Gazal are filled with maps and books and chronicles, all at least 900 years old.

GLOWING GLOBE

A glowing globe is a refined form of green fire-stone (see page 113), and is similar to the radium gems of Xuthal (see page 36). It appears as a glassy knob with a golden glow. A single glowing globe of Gazal provides illumination within a 10-foot radius, weighs a negligible amount, and can be switched on or off up to once per round as a free action by rubbing them with a thumb. However, it still has a tendency to corrupt the carrier, exactly like green fire-stones do.

Anyone who does not have Corruption 1+ will feel distinctly unnerved when in an area lit by one or more radium gems. If he lives in such an area for a week or more, he must make a Corruption save (DC 15) or gain 1 point of Corruption. Characters who already have at least 1 point of Corruption are unaffected, and may even rather enjoy the glow.

MONSTERS OF GAZAL

Drums of Tombalku features demons dwelling in a great red tower in the midst of the green ruin.

OLLAM-ONGA

Medium Outsider (demon)

Hit Dice: 20d8 (90 hp)

Initiative: +22 (+5 Dex, +17 Reflex)

Speed: 40 ft. (8 squares)

Dodge Defence: 31 (+5 Dex, +15 natural, +1 dodge)

Damage Reduction: 15

Base Attack/Grapple: +20/+27

Attack: Claw +27 melee (1d8+7, AP 8)

Full Attack: 2 claws +27 melee (1d8+7, AP 8), bite +25 melee (1d6+3)

Space/Reach: 5 ft. (1)/5 ft. (1)

Special Attacks: Improved grab, rip armour, silence

Special Qualities: Manifest

Power Points: 56 (base 50, +6 Wis)

Magic Attack Bonus: +16 (+10 natural, +6 Charisma)

Saves: Fort +12, Ref +17, Will +18

Abilities: Str 24, Dex 20, Con 10, Int 20, Wis 22, Cha 22

Skills: Balance +28, Climb +30, Craft (alchemy) +28, Craft (herbalism) +28, Decipher Script +28, Hide +28, Intimidate +29, Jump +34, Knowledge (arcana) +28, Move Silently +28, Listen +29, Perform (ritual) +29, Spot +29

Feats: Multiattack, Dodge, Power Attack, Cleave, Great Cleave, Improved Initiative, Steely Gaze

Environment: Any land and underground

Organisation: Solitary

Advancement: –



GAZAL

And before him stood a white, naked figure. Amalric halted, his tongue cleaving to his palate. It was a naked white man, to all appearance, who stood there, gazing at him with mighty arms folded on an alabaster breast. The features were classic, cleanly carven, with more than human beauty. But the eyes were balls of luminous fire, such as never looked from any human head. In those eyes, Amalric glimpsed the frozen fires of the ultimate hells, touched by awful shadows.

Robert E. Howard, *Drums of Tombalku*

Ollam-Onga dwells in a sinister red tower on the edge of the city of Gazal. From here, he stalks the city at night, catching and devouring the peaceful folk of Gazal. They have been cowed by him for generations, and are temperamentally unsuited to fighting in any case. For these reasons they make excellent prey. He delights in eating sentient life, but prefers it not to fight back. When someday he kills the last of the Gazali, he will need to find a new home. Perhaps he will wander back into Kush itself and ally himself directly to one of the various tribes and secret societies that worship him.

Ollam-onga is worshipped by cults in dank jungles and along sullen dusky rivers. Although capable of taking a humanoid form, he is a Cthulhoid monster with a thoroughly alien aspect.

During the story *Drums of Tombalku*, Amalric, an ally of Conan's, slays Ollam-Onga. However, this is an unfinished story, and so it is fairly reasonable for the



Games Master to design a scenario based on it in which the player characters take the places of Amalric and Conan and face Ollam-Onga themselves.

Combat

Ollam-Onga will make extensive use of his Manifest special quality and his excellent Hide and Move Silently skills to escape from an unequal combat and stalk his foes one at a time from ambush. If forced into direct combat, he will concentrate his attacks on the most serious threat, tearing off his armour then tearing him to pieces.

Improved Grab (Ex): If Ollam-Onga hits with his claw attack, he deals normal damage and attempts to start a grapple as a free action without provoking an attack of opportunity. If he wins the opposed grapple check, he gets a hold and may rip armour.

Manifest (Su): As a standard action, Ollam-Onga can either leave Earth and return to his home place, or appear somewhere else on Earth. In either case, he manifests at the new location at the end of his action.

Rip Armour (Ex): When Ollam-Onga is grappling an enemy, he may elect to make a claw attack directly against his enemy's armour rather than against the enemy himself. He makes a standard melee attack roll and if successful any damage he deals is subtracted permanently from the armour's Damage Reduction, as he simply tears it off with his free claw.

Silence (Su): Ollam-Onga's terrifying presence can force his enemies into a stunned silence, in which they dare not speak, overwhelmed by the cosmic horror of the situation. Anyone within 30 feet of him must make a Will saving throw (DC set by his magic attack roll) or be unable to speak until they are at least 30 feet away again and can no longer see him.

Spells (Sp): Ollam-Onga may cast the following spells as though he were a 20th level scholar. The usual Power Point and other costs apply. He has a crystal ball in his tower for use with his *visions* spell.

Divination: *Astrological prediction, dream of wisdom, mind-reading, psychometry, sorcerous news, greater sorcerous news, visions, visions of torment and enlightenment*

Hypnotism: *Entrance, domination, hypnotic suggestion, mass hypnotic suggestion, ranged hypnotism*

Summonings: *Summon demon* (riders of Ollam-Onga only)

Ollam-Onga's Cult

Requirements of Worship: Obey priests of Ollam-Onga, sacrifice at least one human to the god per year.

Benefits of Worship: Spells.

Requirements for Ordained Priesthood: Must know at least three sorcery styles and the

Ritual Sacrifice feat; obey the high priest of Ollam-Onga; sacrifice at least one human per month to Ollam-Onga.

Benefits of Ordained Priesthood: Standard, plus as follows: sorcery teaching is available (any sorcery styles except Oriental Magic).

Typical Punishments for Disloyal Priests: Dedicate the entire resources of the cult to slaying him.

RIDER OF OLLAM-ONGA

Medium Outsider (demon)

Hit Dice: 6d8+6 (33 hp)

Initiative: +11 (+3 Dex, +8 Reflex)

Speed: 30 ft. (6 squares)

Dodge Defence: 17 (+3 Dex, +4 natural)

Damage Reduction: 4

Base Attack/Grapple: +6/+9

Attack: Claw +9 melee (1d8+3 plus hellfire)

Full Attack: 2 claws +9 melee (1d8+3 plus hellfire)

Space/Reach: 5 ft. by 5 ft. (1)/5 ft. (1)

Special Attacks: Hellfire, windblast

Special Qualities: Fast healing 2, fast tracking, manifest

Power Points: 11 (base 10, +1 Wis)

Magic Attack Bonus: +6 (+3 natural, +3 Charisma)

Saves: Fort +6, Ref +8, Will +6

Abilities: Str 17, Dex 16, Con 13, Int 10, Wis 13, Cha 17

Skills: Balance +11, Handle Animal +14, Intimidate +12, Listen +11, Ride +15, Search +11, Spot +11, Survival +12

Feats: Mounted Combat, Spirited Charge, Ride-by Attack, Track

Environment: Any land

Organisation: Solitary or patrol (2-7)

Advancement: By character class (favoured class: nomad)

The riders of Ollam-Onga are black-clad horsemen riding jet-black mounts. They wear black, flowing cloaks over baggy black robes. The only things visible from beneath these robes

As darkness came on, so came the black riders. Amalric glanced at Lissa, and a groan burst from him. His stallion stumbled and fell. The sun had gone down, the moon was blotted out suddenly by a bat-shaped shadow. In the utter darkness the stars glowed red, and behind him Amalric heard a rising rush as of an approaching wind. A black, speeding clump bulked against the night, in which glinted sparks of awful light... Seven black shapes loomed against the stars, racing like the wind. Under the hoods shone balls of evil fire. Jaw bones seemed to clack together.

Robert E. Howard, *Drums of Tombalku*



GAZAL

are skeletal black claws and the riders' flame-like eyes. When the riders' horses are moving at a gallop, the riders' cloaks billow out behind them in a manner reminiscent of bat-wings. Riders of Ollam-Onga are around the same size as humans, though the precise form of their bodies, if they have any, is impossible to discern under their robes.

The riders gain their name for their allegiance to the demon lord Ollam-Onga. There are only seven of them, and all serve the demon lord personally, or are assigned by him temporarily to serve one of his more powerful worshippers. If Ollam-Onga is ever slain, all seven of his riders will appear 1d6 hours later,

Riders of Ollam-Onga speak Demonic and Riders of Ollam-Onga are always encountered riding uncanny steeds.

Summoning Requirements

A rider of Ollam-Onga who is summoned with a *summon demon* spell or similar will only come if there is already an uncanny steed present, ready for him to mount and command. This uncanny steed may also be summoned by a *summon demon* spell, or may be available due to the sorcerer's *demonic pact* with it. Furthermore, riders of Ollam-Onga can only be summoned by a *summon demon* spell if the sorcerer

is a worshipper of Ollam-Onga (see page 71), or has a *greater demonic pact* with that demon lord.

Combat

Riders of Ollam-Onga favour charge attacks, riding down their terrified foes. Enemies who seem to be somehow outdistancing them will be knocked over or off their horses with the riders' windblast attack. Riders of Ollam-Onga are somewhat cowardly and will not fight against overwhelming odds or enemies clearly more powerful than them, even if they could potentially kill their targets at the cost of their own lives. Rather, they will prefer to flee, trusting to their uncanny mounts' speed to carry them out of danger.

Fast Healing (Ex): A rider of Ollam-Onga heals 2 points of damage each round so long as it has at least 1 hit point.

Fast Tracking (Ex): A rider of Ollam-Onga can track without penalty while moving at the full speed on his uncanny mount.

Hellfire (Su): Every time a rider of Ollam-Onga hits an opponent, its touch burns them painfully. This deals +2d6 heat damage. The target may attempt a Fortitude save, DC 14, for half damage. A target who fails his saving throw may only take either a move action or a standard



action on his next action due to the pain of the injury. The saving throw DC is Constitution-based.

Manifest (Su): As a standard action, the rider of Ollam-Onga can either leave Earth and return to its home place, or appear somewhere else on Earth. In either case, it manifests at the new location at the end of its action.

Windblast (Sp): At a cost of 3 PP, the rider of Ollam-Onga may conjure up a magical blast of wind that can knock over opponents and render missile fire ineffective. This strong blast of wind originates from the rider and moves in the direction the rider is facing. The force of this blast automatically extinguishes candles, torches, and similar unprotected flames, affecting an area 10 feet wide and 100 feet long. Creatures caught in the area must make Fortitude saving throws (DC set by the rider of Ollam-Onga's magic attack roll) or be knocked prone. A creature riding another creature may substitute his Ride skill check result for his Fortitude saving throw if desired, so long as his mount has succeeded in its own saving throw – if he fails, he is knocked off his mount, being dealt 1d6 damage in the process, and is prone. A gust of wind can also do anything a sudden blast of wind would be expected to do. It can create a stinging spray of sand or dust, fan a large fire, overturn delicate awnings or hangings, turn over a small boat, and blow gases or vapours to the edge of the range.

Skills: Riders of Ollam-Onga gain a +4 racial bonus to all Ride checks a +2 racial bonus to all Handle Animal and Survival checks.

NEW RACE

GAZALI

The Gazali, a Hyborian offshoot, dwelt in southern Koth almost a millennium ago. The Gazali were noted for their scholarly wisdom but they were forced to leave Koth when they tried to revive the worship of Mitra, a religion the Kothians had long abandoned. The Gazali (comprised of priests, scholars, teachers and scientists) travelled south with their Shemitish slaves, through Shem and Stygia, into the Black Kingdoms. Under the influence of Ollam-Onga the Gazali have become dreamy and introspective, losing human passions and ambitions.

Culture: The Gazali culture is predominantly Kothic although they worship Mitra. Theirs is a quiet, introspective culture of science and discovery. Their learning is a marvel. The Gazali leaders probably have a demonic pact with Ollam-Onga, who has taught them the *fruit of air* spell (from *Conan: The Scrolls of Skelos*).

Names: These seem to be based on traditional Kothic names. Examples: (female) Lissa

Religion: The Gazali worship Mitra and Ollam-Onga to a lesser degree.

Other than as follows, they are a subrace of the Hyborians and use their basic traits.

☼# No Weapon Familiarity. Unlike other Hyborians, the Gazali do not gain weapon familiarity with the greatsword.

☼# The Gazali do not get the racial bonus for Fate Points other Hyborians get.

☼# -1 racial penalty to all attack rolls. The Gazali are not merely untrained in the ways of war, they completely lack the temperament to willingly engage in combat. This penalty no longer applies if the Gazali ever gains a martial weapon proficiency.

☼# Literate: Although many Gazali are little more than commoners now, they are all literate and, even if they take the commoner class or another class that is illiterate, they do not have to spend 2 skill points to gain literacy.

☼# Corrupt: Having lived so long with glowing globes and the influence of demons, all Gazali begin their careers with 1 point of Corruption. Something is wrong with the Gazali and it is readily seen, if not identifiable.

☼# Cannot take ranks in Ride or Handle Animal at 1st level because there are no horses, camels or pack animals in Gazal. The Gazali simply have no experience with domesticated animals.

Background Skills: Knowledge (history), Knowledge (religion), Knowledge (geography)

Favoured Class: Scholar

Prohibited Classes: Barbarian, Borderer, Nomad, Pirate, Soldier

Automatic Languages: Ancient Kothian

Bonus Languages: Shemitish



The Isle of Iron Statues

IRON SHADOWS IN THE MOON

IRON SHADOWS IN *the Moon* (also known as *Shadows in the Moonlight*) is another Robert E. Howard tale featuring a green-stone ruin.

HISTORY

Amid a great green-stone city of cyclopean blocks and columns lived a black-skinned warrior race. These were not a Negroid race despite the black skin. Their garments and weapons were unlike anything found in the Hyborian Age and they lived among green and scarlet plumed parrots and worshipped a horrible demon at the centre of their city.

This race captured a white-skinned youth with golden curls and an alabaster brow. The youth was inhumanly beautiful and appeared to be chiselled out of living marble. The arrogant warrior-race tortured the naked youth and tied him to one of the pillars of the great hall. He was tortured to death in a horrible ritual until his life was finally ended by a ritual dagger that cut his throat – but not before the youth cried out to the skies beyond.

An immortal and awful being was summoned by the youth with his cry, an inhuman beauty even more godly and alien than the youth – although the resemblance was clear. The horrible entity forced the dark-skinned race to stand between the pillars of their great hall then he uttered the *invocation of Xuthalla*, which turned them into living statues of iron. The being also indicated that they may animate and live only while the moonlight shone down upon them.

LAYOUT

THE ISLAND

The oval island of iron statues is on the Vilayet, one of many that dot the inland sea. This particular island is a green wall of trees and shrubbery rising from the water's edge. A small bay where the waters lie calm as glass is the easiest way to land on the island. Conan rowed for a night after losing sight of the mainland to reach the island. The Hyrkanians generally avoid the island.

The island is covered in trees, thickets, cliffs, plateaus and slopes. The trees hug the shoreline, with roots dipping into the Vilayet. Birds flit amid the trees and the leaves murmur with the soft breezes moving through.

The island is beautiful. Leaving the shore, characters will pass under leafy arches of great branches and green swards will cushion their footfalls. Faery-like vistas can be glimpsed through the limbs and trunks of the trees. The trees form a jade canopy overhead, blocking out much of the sky.

The island also provides food. Golden and russet globes of fruit hang from many of the trees, sweet and great tasting but not terribly filling.

A plateau on the island holds the green stone ruin. The plateau, whose sides fall away toward the wooded shores on the east, west and south, slopes upward in the north until the slope becomes a tangle of rocky cliffs, the highest point on the island. Trees grow thick along the rim of the plateau to the east and west of the cliffs and along the precipitous incline. The slope is not sheer but broken by ledges, boulders and other natural hand- and foot-holds (Climb DC 15). The other side of the cliffs is a sheer precipice three or four hundred feet down to a narrow bit of woodland bordering a beach. Even from the pinnacle, no other land can be seen.

THE RUIN

Passing through thickets and forests to a grassy slope where the trees thin and the grass grows tall, the characters will climb to a plateau with even taller grasses and fewer trees. On this plateau is a long and broad edifice of crumbling greenish stone. Moss and lichen grow over much of the cyclopean ruin and its broken roof leaves most of the ruin open to the sky. It is constructed like most of the lost green-stone cities, although this one has fallen into severe ruin. Robert E. Howard describes it: 'On all sides lay bits and shards of masonry, half hidden in the waving grass, giving the impression that once many buildings rose there, perhaps a whole town. But now only the long hall-like structure rose against the sky, and its walls leaned drunkenly among the crawling vines.'

The long central hall is all that is intact within the ruin. The doors have long since rotted away leaving the ruin open. Gaps exist in the walls and roof, which makes the interior a mixture of streaming light and dim shadows. The floor is of polished green stone, but dust and fallen ceiling stones litter the floor. Vines grow between the stones, splitting them and blocking



out many of the openings and windows. Thick columns rise up to the rooftop and in between each column is an iron statue of a tall arrogant looking figure.

The life-size statues of lithe and naked men are black and shining. Every conceivable detail of these naked men is realistically portrayed, but each statue is unique. There are commonalities to the statues, though; the faces are arrogant, hawk-nosed sorts, giving the impression of proud superiority and intolerance. Unknown to most, though, the statues animate whenever moonlight strikes them.

Although the central core of the ruin was not reached by Conan, the culture is known to have worshipped demons housed in a central well or tower. That unnamed and unknown demon possibly still lurks there, trapped beneath fallen greenish masonry.

Anyone who sleeps within the ruin may have a dream about the history of the island and the final days of its people.

Exploring any part of the ruin other than the central hall is fraught with danger. Moving around the other areas of the ruin is dangerous. Every ten minutes a character spends moving around in these areas he must make a Reflex save (DC 10) or take

1d4 blunt damage from falling debris. If the character rolls a natural 1 he takes damage and twists his ankle, reducing his movement speed by ten feet per round until someone takes the time to make a Heal check (DC 15).

MAGIC & UNUSUAL ITEMS HIDDEN IN THE RUINS

There are unknown secrets and monstrous things lurking in the ruins on the Isle of Iron Statues. Although Conan did not find any treasure here, undoubtedly there are untold treasures hidden throughout the ruin, as with most other green-stone ruins.

MONSTERS OF THE CURSED ISLAND

Iron Shadows in the Moon features horrible giant man-apes, animated statues of iron and some form of godling and his child. Statistics for man-apes can be found in *Conan the Roleplaying Game* core rules.

IRON SHADOWS

Soldier 4

Medium Construct

Hit Dice: 2d10+20 plus 4d10 (53 hp)

Initiative: +1 (+1 Reflex)

Speed: 40 ft. (8 squares)

Dodge Defence: 12 (+2 level)

Parry Defence: 14 (+1 Str, +3 level)

Damage Reduction: 8

Base Attack/Grapple: +5/+6

Attack: Slam +6 melee (1d8+1, 19-20, x2)

Full Attack: Slam +6 melee (1d8+1, 19-20, x2)

Space/Reach: 5 ft. (1)/5 ft. (1)

Special Attacks: Formation combat (skirmisher), rending grip

Special Qualities: Construct traits, darkvision 60 ft., low-light vision; also see text

Saves: Fort +4, Ref +1, Will +2

Abilities: Str 12, Dex 10, Con —, Int 17, Wis 12, Cha 16

Skills: Climb +10, Intimidate +13, Jump +12, Knowledge (arcana) +10, Knowledge (local) +7, Perform (ritual) +7, Search +8

Feats: Power Attack, Improved Critical (slam), Improved Grapple, Improved Sunder, Skill Focus (Intimidate)

Environment: Isle of Iron Statues

Organisation: Solitary

Advancement: —

The Iron Shadows are nude male statues created by the invocation of *Xuthalla* spell (see *Conan: The Scrolls of Skelos*). The statues are seemingly made of polished iron and are uncannily accurate in all details. They animate when the moonlight touches them. As the night wanes, the statues

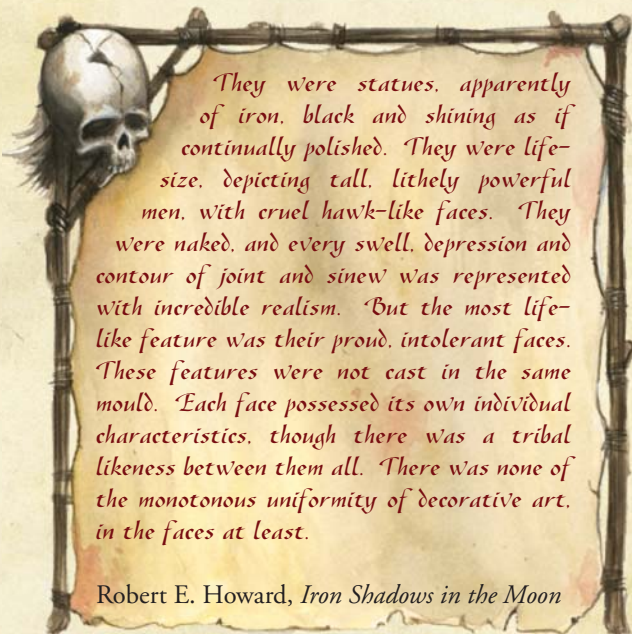

Robert E. Howard, *Iron Shadows in the Moon*



will make every effort to stand once again against the wall, losing animation when the moonlight vanishes.

The only way to restore a statue to life is with a *greater warding* spell. However, although the statue is immune to aging, the human who was turned into the statue is not – if restored to human form, he will immediately age to reflect the amount of time he spent as a statue. This can lead to victims of this spell simply dying of old age when ‘saved’ from their curse by a helpful sorcerer.

Combat

They are immediately aggressive and will fall upon anyone in the great hall, rending those persons limb from limb.

Rending Grip (Ex): The mighty thews of their horrible iron hands and arms can crush a man’s limbs or neck in moments, if they can but get a grip on him. If one of these iron statues manages to grapple an opponent and inflict damage on him, it may choose to inflict some or all of the rolled damage as damage to his Constitution, Dexterity or Strength, at its choice. The victim gets a Fortitude saving throw (DC 13) for half damage. Rending Grip may be continued from round to round, so long as it is grappling its opponent and inflicting damage upon him.

IRON STATUES

Isle of the Black Ones

USURPERS OF THE RUINS

THE ISLE OF the Black Ones, several weeks to the west of Zingara, is mentioned in the mysterious *Book of Skelos*, and it is written that this island holds crypts filled with hieroglyph-carven gold, guarded by strange monsters.

HISTORY

Originally built via magic, possibly as a cultural outpost, the castle on this isle was deserted for unknown reasons prior to the Great Cataclysm. The black ones either drove off the original builders or arrived just after they left.

LAYOUT

The island is beautiful and winds bring the scent of fresh vegetation and spices to ships just off its coasts.

THE ISLAND

The island is difficult to reach, as it is uncharted. A shallow bay affords easy entry onto the island by ship. The island is surrounded by a white girdle of sand.

Once past the beach, the island is thick woodland. Fruit and fresh water are both easily found with a Survival or Knowledge (nature) check (see Foraging DCs for Edible Food and Drinkable Water table). A Survival check (DC 10) or a Knowledge (nature) check (DC 5) can determine if food is safe for consumption (although a certain golden-skinned fruit does have a nonlethal side effect – see the sidebar). The degree of success indicates the level of success in foraging. Foragers who beat the DC by 5 or more find enough to feed four people. Beating the DC by 10 or more results in finding enough food to feed eight people. There is no limit to the number of foragers searching, however, for every increment of four searchers, the range of the search must increase by 1 mile. A standard search assumes one mile of searching. Characters with 5 ranks in Craft (herbalism) or Knowledge (nature) receive a +2 synergy bonus to these checks.

Foraging DCs for Edible Food and Drinkable Water

Survival Need	Winter	Spring	Summer	Autumn
Fresh Fruit	14	12	10	12
Drinkable Water	24	22	24	24

On a result failed by five or more when searching for food or water, the character has accidentally ingested something harmful. While most plants are really not lethally poisonous, there are a few that are deadly. Water, on the other hand, is usually obvious if something is amiss. However, if an individual consumes foul water the results are often severe. Characters having drunk bad water or inedible food must roll a d100. If the result is 1-15, then the plant or water is poisonous. Effects can include random ability damage on a failed Fortitude save, sweating, cramps or even disease. See the Effects of Contaminated Food or Water table for sample results.

Effects of Contaminated Food or Water

d20	Fortitude DC	Primary/Secondary Damage
1-5	15	0/Unconsciousness
6-10	14	1d4 Int/2d6 Int
11-13	11	1 Wis/2d6 Wis + 1d4 Int
14-16	13	1 Con/1d8 Con
17-18	17	2d6 Str/1d6 Str
19	18	2d6 Con/1d6 Con + 1d6 Str
20	Varies	Disease as determined by Games Master

Beyond the forest belt, the island is an expanse of gentle grassy slopes with even swards and clustered groves. The general trend as one moves inland is upward, even as one ascends and descends the gentle slopes with monotonous regularity. The array of small hills are seemingly endless. Until the summit of the island is reached, the shining green walls of the ruin are almost impossible to see against the green landscape (Spot DC 42 until the summit is reached or other reasonably close distance is attained).

Golden Fruit of the Isle

The delightful golden-skinned fruit with the sweet and cloying smell has a soporific effect on those who eat it. The target must make a Fortitude save (DC 20) or fall into slumber for 2d4 hours. During this time the affected character may have visions of the past or the future. The Black Ones will usually act against all affected characters, carrying them to the Pool for sacrifice.

THE GREEN-STONE RUIN

The ruin is composed of shining green walls and towers. The wall is circular and made entirely of semi-translucent green stone. Entry to the ruin is accomplished via a tall archway in the curving wall; there is no door. Inside the archway is a broad open court covered in grass. Various arches open from the circular court. The plan of the ruin is a great number of circular courts surrounded by walls and connected through open arches, all grouped around a cluster of fantastic towers in the centre.

One of the courts does not have smooth walls like the rest. Its walls are banded with long ledges and crowded with small objects. In the midst of this strange court is a dark green pool – the demon that lurks at the heart of all green-stone cities. The pool is placid but glimmers, as though one were looking through thick green glass. It is bordered by green jade and is incredibly deep. A faint luminosity can be seen in its depths at times.

Set upon the long ledges in that circular wall are thousands of tiny, mostly greyish figures about the length of a man's hand. They are clear enough that racial characteristics can be made out, such as Zingarans, Argosseans, Ophireans and Kushites. The Kushite figures are black, not grey. Modern races are on the upper shelves, the lower shelves hold extinct or ancient races. They feel as though made of petrified bone.

MONSTERS OF THE ISLE OF THE BLACK ONE

BLACK ONES

Large Outsider (native)

Hit Dice: 10d8+50 (95 hp)

Initiative: +11 (+2 Dex, +9 Reflex)

Speed: 25 ft. (5 squares)

Dodge Defence: 19 (-1 size, +2 Dex, +8 natural)

DR: 7

Base Attack/Grapple: +10/+20



Attack: Claw +15 melee (1d8+6)

Full Attack: 2 claws +15 melee (1d8+6) and bite +10 melee (1d4+3)

Space/Reach: 10 ft. (2)/10 ft. (2)

Special Attack: Whistle

Special Qualities: —

Magic Attack Bonus: +8 (+5 natural, +3 Cha)

Saves: Fort +12, Ref +9, Will +7

Abilities: Str 22, Dex 15, Con 20, Int 14, Wis 10, Cha 16

Skills: Balance +15, Bluff +16, Climb +19, Hide +11, Intimidate +16, Jump +19, Knowledge (arcana) +15, Move Silently +15, Perform (ritual) +16, Perform (pipes) +10, Search +10

Feats: Cleave, Improved Sunder, Power Attack, Steely Gaze

Climate/Terrain: Isle of the Black Ones

Organization: Solitary, group (6-10), or the entire group of 50

Advancement: —

No one knows the origin of the Black Ones, save perhaps those mad scholars who drink deep of the wisdom contained in the Scrolls of Skelos. Whatever it is, they seem to inhabit a single island far out in the Western Ocean. What purpose it serves, if any, cannot be guessed. Similarly their dark desire to take a victim to their

THE BLACK ONES



The superb symmetry of body and limbs was more impressive at close range. Under the ebon skin long, rounded muscles rippled, and Conan did not doubt that the monster could rend an ordinary man limb from limb. The nails of the fingers provided further weapons, for they were grown like the talons of a wild beast. The face was a carved ebony mask. The eyes were tawny, a vibrant gold that glowed and glittered. But the face was inhuman: each line, each feature stamped with evil - evil transcending the mere evil of humanity. The thing was not a human - it could not be: it was a growth of Life from the pits of blasphemous creation - a perversion of evolutionary developments.

Robert E. Howard, *The Pool of the Black One*

great green pool, hold it within, and transform it into a palm-sized statue devoid of live can only be understood by minds that move in the same, inhuman ways as their own.

These creatures appear to have existed for centuries, if not millennia, on the Isle. They constructed an elaborate city at one point; the ravages of time transformed that city into a ruin long ago. Of the handful left, most refuse to ever speak to a mortal; indeed they fight in utter silence, not even grunting or gasping as they slay.

There may be a great treasure of gold and silver located on the island. However, only the mightiest could hope to possibly deal with these creatures, their diabolic intelligence, and the sorcery of their leader.

Combat

The Black Ones have no respect at all for humans. They regard humans as animals but recognize an armed human as a potential threat. As such, they will typically wait until hungry crews drug themselves on the fruit of their island (see Golden Fruit of the Isle) before gathering the main bulk for transformation into statues. Stragglers, or those who go off alone, will be quickly attacked by at least one of these creatures, often with a small group waiting nearby in case the hunter needs assistance.

When attacking in melee combat the black one may choose to either

rend with his claws (inflicting slashing damage) or close his hand into a great fist (inflicting blunt damage). In addition, all Black Ones have the following special ability:

Whistle (Su): Once per day the Black One may use his thin black flute to target a creature within evil eye range. On the first round he casts *entrance* on the target; on the second round he casts *domination*. These abilities function just like the spells of the same name.

HIGH PRIEST OF THE BLACK ONES

Scholar 6

Large Outsider (native)

Hit Dice: 10d8+50 plus 6 (101 hp)

Initiative: +15 (+3 Dex, +12 Reflex)

Speed: 25 ft. (5 squares)

Dodge Defence: 21 (-1 size, +2 Dex, +8 natural, +2 class)

DR: 7

Base Attack/Grapple: +14/+24

Attack: Claw +19 melee (1d8+6)

Full Attack: 2 claws +19 melee (1d8+6) and bite +14 melee (1d4+3)

Space/Reach: 10 ft. (2)/10 ft. (2)

Special Attack: Whistle

Special Qualities: +2 Power Points, advanced spells x4, background, base Power Points, bonus spell, increased maximum Power Points (triple), knowledge is power, new sorcery style x3, scholar

Power Points: 7 (4 base, +1 Wis, +2 bonus; 21 maximum)

Magic Attack Bonus: +12 (+5 base, +3 level, +4 Cha)

Saves: Fort +14, Ref +12, Will +15

Abilities: Str 23, Dex 16, Con 21, Int 15, Wis 12, Cha 18

Skills: Balance +16, Bluff +17, Climb +19, Concentration +9, Hide +16, Intimidate +23, Jump +19, Knowledge (arcana) +21, Knowledge (local) +10, Knowledge (nature) +6, Move Silently +22, Perform (ritual) +23, Perform (pipes) +22, Search +15

Feats: Cleave, Improved Sunder, Iron Will, Power Attack, Ritual Sacrifice, Steely Gaze, Tortured Sacrifice

Sorcery Styles: Hypnotism, Curses, Summonings

Spells Known: *Demonic pact, domination, entrance, greater ill-fortune, ill-fortune, lesser ill-fortune, summon demon, summon elemental*

Climate/Terrain: Isle of the Black Ones

Organization: Solitary, group (6-10), or the entire group of 50

Advancement: —

The leader of the Black Ones is also a 6th level scholar. He wears a jewelled headband, the only clothing seen on any of these creatures. His knowledge of sorcery extends back centuries.

POOL OF THE BLACK ONE

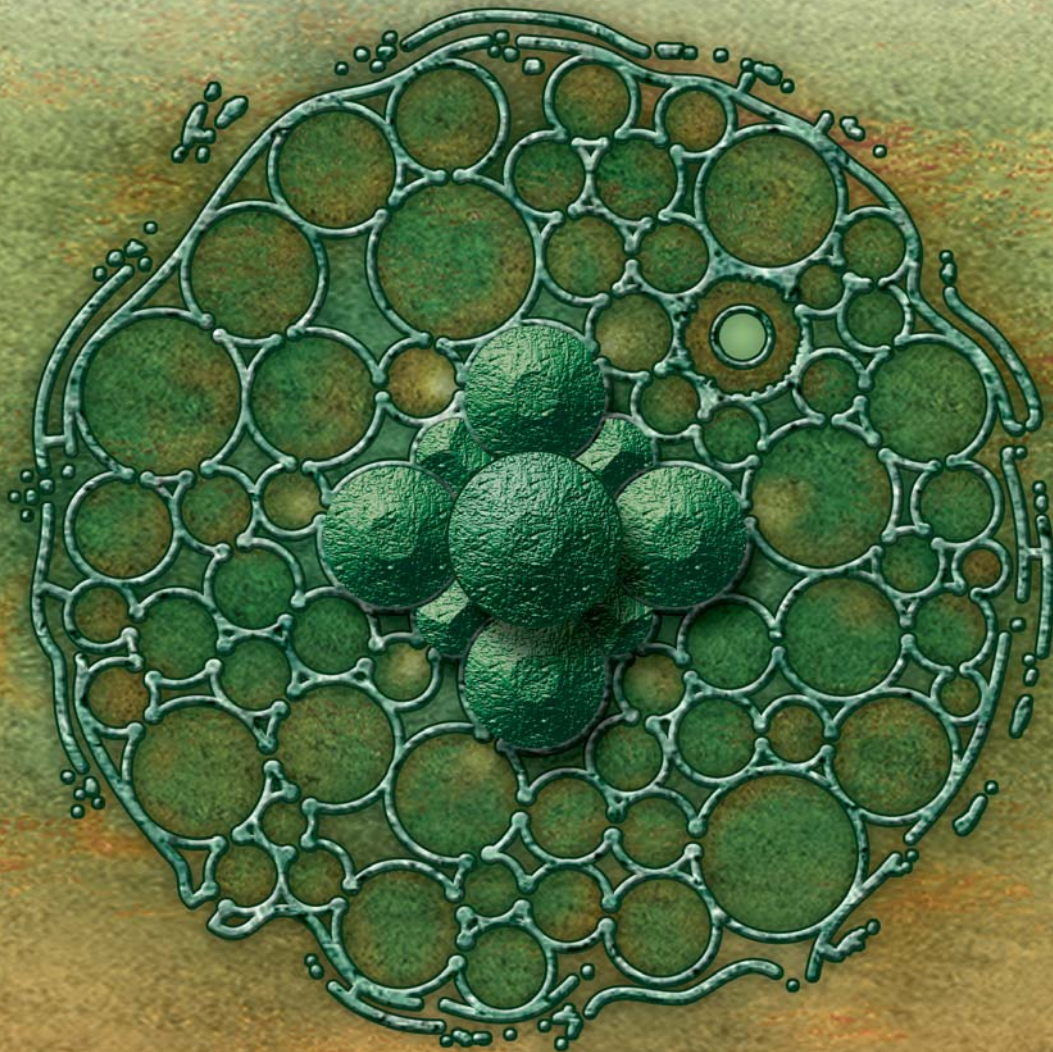

THE BLACK ONES

Whistle (Su): Once per day the black one use his thin black flute to target a creature within evil eye range. On the first round he casts *entrance* on the target; on the second round he casts *domination*. These abilities function just like the spells of the same name.

THE POOL OF THE BLACK ONE (NAME UNKNOWN)

Colossal Outsider (demon)

Hit Dice: 32d8+256 (400 hp)

Initiative: +12 (-3 Dex, +15 Reflex)

Speed: 20 ft. (4 squares)

Dodge Defence: 23 (-8 size, -3 Dex, +24 natural)

DR: 12

Base Attack/Grapple: +32/+63

Attack: Slam +39 (4d6+15, 19-20, x2, AP 20)

Full Attack: Slam +39 (4d6+15, 19-20, x2, AP 20)

Space/Reach: Variable/ 15 ft. (3)

Special Attacks: Engulfing torrent, fetish-making touch

Special Qualities: Immunities, improved grab

Power Points: 55 (base 50, +5 Wis)

The green pool was like a geyser now, the noise rising to deafening volume as the great column of water reared and reared, blossoming at the crest with a great crown of foam... Its green trunk was laced with white: its foaming crown was thrice the circumference of its base. Momentarily it threatened to burst and fall in an engulfing torrent, yet it continued to jet skyward... It was as if a gigantic green-stemmed and white-blossomed flower swayed above the towers, the roar filled the sky. Then the jade-green and snowy pillar broke with a noise like the rending of the skies, and the walls and towers were blotted out in a thunderous torrent... The torrent had not spread out and dissipated: like a giant serpent it flowed over the depressions and the rounded crests. It held a consistent course - it was following them... The green river burst through the fringe of trees. Those trees fell as if their stems had been cut away, and as they sank into the jade-coloured flood, they vanished. The tide flowed out over the beach, lapped at the ocean, and the waves turned a deeper, more sinister green.

Robert E. Howard, *The Pool of the Black One*

Magic Attack Bonus: +21 (+16 natural, +5 Charisma)

Saves: Fort +26, Ref +15, Will +23

Abilities: Str 40, Dex 4, Con 27, Int 28, Wis 20, Cha 20

Skills: Climb +50, Concentration +43, Craft (alchemy) +44, Craft (herbalism) +44, Decipher Script +44, Gather Information +40, Intimidate +40, Knowledge (arcana) +44, Knowledge (history) +35, Knowledge (nature) +35, Knowledge (religion) +35, Listen +40, Move Silently +32, Search +44, Sense Motive +40, Spot +40, Survival +36, Swim +50

Feats: Power Attack, Cleave, Die Hard, Endurance, Great Cleave, Improved Bull Rush, Improved Critical (slam), Improved Overrun, Menacing Aura, Steely Gaze, Track

Environment: Any land and underground

Organisation: Solitary

Advancement: –

The Pool of the Black One is a demon lord worshipped by the Black Ones. Sacrifices are dunked into its green gelatinous body and turned into small petrified fetishes, their souls devoured by the demon lord. It moves as a massive river of emerald green, but can only extend a few miles from the well where it is contained.

It is intelligent but its intelligence is alien in all ways. If it speaks, it does not do so in any manner discernable to human beings.

Anyone hitting the pool with a slashing weapon risks being covered in horrible, fetish-making gore (Reflex save DC 18 for only 1d12 points of damage; failure means the character must make the Fortitude save described in its special attacks).

The Pool of the Black One is capable of teaching all spells, both those found in *Conan the Roleplaying Game* as well as any supplements, although it rarely casts spells itself (it may cast *fruit of air* to sustain the black ones in return for the sacrifices).

Combat

The demon often attacks anyone above it with a grapple. Anyone thrust into the demon's body is also effectively grappled.

Fetish-making Touch (Su): Anything that falls entirely within the greenish ooze that comprises the demon's body is petrified and shrunk (Fortitude save to avoid set by Pool's magic attack bonus). Each round of contact causes another save. People are shrunk to approximately the length of a man's hand; feet become inches, so a six-foot man becomes a six-inch statuette apparently made of petrified bone. The only things apparently immune to this touch are the greenstones used to build the castle around it. The touch kills and destroys plant-life, causing trees to crumble and fall into the gelatinous body of the demon, which, in turn, shrinks and petrifies the trees.

Engulfing Torrent (Ex): The demon of the pool can jet skyward, pulling its entire mass from the nether realms into a massive plume of green, viscous liquid and white foam. Once it has pulled itself up, it can then collapse itself down into a city-sized mass of green liquid, petrifying and shrinking virtually anything in its wake. This attack takes 20 rounds to implement.

Khet

THE CITY OF SCORPIONS

THE RUINS OF the 'City of Scorpions' lie along the River Styx and were once the centre of worship for Selkhet. The city was abandoned and fell to ruin several centuries ago. This was once the centre of Selkhet's worship as a goddess of magic and childbirth before the Stygians altered her nature. Nomads occasionally pass near or through the ruins, often to allow their herds to drink out of the abandoned and broken canals.

HISTORY

During the Fall of Acheron, the city now known as Khet was still a town with an unknown name, focused on producing barley wine and bricks. Khopshef CLXXIII, one of the last of the god-kings of Stygia, gave the village to Acheronian refugees for their use. Among the Pythonians were priests of Selkhet; who subordinated their scorpion-goddess to Set and settled in the town, naming it Khet and building it into a grand city of black stone. Although nowhere near as grand as Python or any other purple-towered Acheronian city, it still was a jewel along the Styx.

Shortly after the arrival of the Acheronian refugees, the city decided to honour the king who gave them a place to live. A mad artist from Budhra (a kingdom now unknown save for the name) named Ekba built a magical statuette of Selkhet and presented it to Khopshef, who built a shrine for it in Luxur. Selkhet was the goddess of magic at this time and was called upon to provide sorcerous protection for the nobles.

The city was a haven for scholars. A great library of sorcerous knowledge was built on the temple grounds as the Acheronian settlers attempted to put their knowledge down in writing, for few of their books and scrolls made it out of Acheron during its blazing fall. Another temple was built in her honour as a centre of childbirth and medicine. The priests and priestesses took on Stygian acolytes to learn Acheronian methods of birthing.

The annual flooding of the Styx gave the city its life, allowing its fields and orchards to grow and feeding the brick-making industry. Although all the major buildings were made of black stone, the poorer houses and workshops were built of mud-brick. One year was almost a total disaster for Khet, a year when the flooding of the Styx exceeded its normal maximum and actually flooded almost to the Temple of

Selkhet's entrance. The ruler of Selkhet had to abandon his palace, and much of the industry and poorer houses were washed away in a deluge of water that killed almost 40% of the population.

Khet recovered and entered into an age of peace. The priests of Selkhet enjoyed the favour of the priest-kings and the population grew. The period of peace lasted 30 years when the priests of Set in Luxur grew jealous of the favour in which the priest-king held the priests of Selkhet. These priests bartered with the Shemites and allowed a tribe of their nomads to sneak into Stygia and attack Khet. The priests and nobles of Khet were the specific targets but most of Khet was enslaved by the Shemites and dragged off.

Seven months later, Nekhwemmut, a former high priest of Selkhet, living as a slave in Shem, murdered his master and family at night and rallied the slaves and they stole away at night, after slaughtering most of the nomad tribe that held them, and returned to Khet. The Stygians had repopulated the city and the returning Khetians were not welcome. Fighting and sorcery burned through the city for three days, leaving the former slaves again in charge of their city.

The city entered another age of building, and four great colossi were built on the edge of the desert behind the bulk of the city, colossi celebrating the four heroes of the conquest of Khet. Nekhwemmut, the high priest who led the slaves out of Shem, died during the revolt in Khet and a pyramid of black stone was built for him. Two great canals were built to increase the fertility of the land and to lead the way to the pyramid complex behind the temple.

Misfortune hit Khet during the Plague of Karnefhere. A Stygian noble of Acheronian descent, Karnefhere had the title of Master of Khet, the Scorpion of the King. He was also a priest of Set and he decided to build a temple to Set grander than the temple of Selkhet across the canal next to Selkhet's temple. As soon as the construction began, a plague struck. The plague afflicted the nobles first and, later, the poor. It is described in scrolls from the period as a black wind from a gaping tomb, the breath of Selkhet. Karnefhere was devoured by a Stygian serpent, the construction of the Temple to Set was halted, bringing an end to the plague.

KHET

RUINS OF KHET



KHET

During the Years of Dissolution, Khet was abandoned and the sands overtook most of it. Wars were fought in its streets and its youth was conscripted into armies as Stygia tore itself apart in unending civil wars. The goddess of Khet was relegated to a goddess of the dead (reflecting the status of her city as a ruin) and is believed to make the dead fertile. Her priesthood died out and the city was forgotten.

LEGENDS

Nomads report seen strange lights at night around the ruins and claim a Lamia lives there.

If a person goes to the Temple of Selkhet and brings an offering of food and beer and chants the name 'Iä-Amun' for an hour, the ghost of the last high priest will materialise and, silent as the grave, walk solemnly from the dark inner recesses of the temple to the place where he had the temple treasures hidden before the city was abandoned. Unfortunately, the ghost vanishes into the dunes, so no one has been able to use this to their advantage as yet.

Nomads talk in hushed whispers of encounters with strange, gnarled, blue-robed little people roaming around the ruins at night.

A powerful artefact, rumoured to be on a par with the Heart of Ahriman, was built on this site, although it was later moved to Luxur, then, during the Years of Dissolution, hidden in a tomb and lost.

LAYOUT

Great black structures loom oppressively over the sands that are slowly swallowing the ruins. The buildings often have scorpion motifs, as well as a large number of statues depicting Selkhet. She appears as a beautiful nude woman with the head and tail of a scorpion.

Homes and workshops are made out of sun-dried mud-bricks but all major structures (such as temples, palaces, obelisks, colossi, wharves, pylons and statues) are made out of black stone. The entrances to almost all enclosed areas are made between two massive pylons decorated with stylized art

depicting priests, priestesses, monsters, gods and goddesses. Writing and art are everywhere. Broken colossi of Selkhet line the River Styx.

Much of the city is buried beneath sand dunes. Sometimes the rooftops can be seen, sometimes nothing of the back half of the city can be seen, depending on the wind and the action of the dunes. Much of the back half of the city has been effectively reduced to rubble from the weight of the dunes on top of them, so little more than foundations can be found even if one went digging. The tops of the four colossi can usually be seen above the dunes, though they have been weathered; scoured by wind and sand.

1. **Homes of the Priests:** These large houses used to be the living quarters of the high priests and priestesses of the temple. Their roofs have long since fallen in, covering the floor with rubble.
2. **Noble Estates:** Four noble estates once existed in Khet; all of them are buried beneath the sand dunes, reduced down to their foundations.
3. **Officials' Housing:** These houses are constructed along the same lines as the priest homes. Almost all of these structures have been reduced to their foundations by the sand dunes; only a few still survive in front of the dunes, yet even these are little more than a maze of walls.
4. **Palace:** The Master of Khet lived here in a grand palace that is mostly intact but completely looted and empty.
5. **Pyramid Complex:** Not shown on the map, the pyramid complex is mostly hidden beneath the sands. Even the pyramid of Nekhwemmut has mostly collapsed to the point where it looks like a massive pile of crumbled stone instead of a four-sided regular pyramid.
6. **Temple of Childbirthing:** This temple was where healers worked and trained, teaching the ancient knowledge of the Giant-Kings and the Acheronians. Other than the retaining walls, it has mostly fallen down to its foundations, although rumours tell of serpentine underground chambers beneath this temple where inhuman things dwell in eternal darkness.
7. **Temple of Selkhet:** The Temple of Selkhet is reasonably intact. The massive walls and pylons of the temple complex have largely protected the Temple of Selkhet from the dunes, but the wall has crumbled in two places, allowing sand to blow in through the centre. A pit is within where human sacrifices were thrown screaming to a nameless amorphous monstrosity from Hell.
8. **Workshops & Housing Clusters:** These ruins are where the working classes and poor lived and worked. Little more than foundations remain and most of this section is buried beneath sand dunes.

MAGIC & UNUSUAL ITEMS HIDDEN IN KHET

The temple treasures are said to still be hidden somewhere beneath the dunes of Khet, possibly within the pyramid complex. Among the temple treasures is the *Ankh of Selkhet*.

ANKH OF SELKHET

The golden Ankh of Selkhet allows a character to cast *summon beast* (see *Conan the Roleplaying Game*) for 2 Power Points (he does not need to know the spell), but it only summons a swarm of scorpions. If a character is not a dabbler or sorcerer (or a dabbler or sorcerer without Power Points), he must willingly accept a point of Corruption each time the Ankh is used (instead of Power Points), which will slowly add scorpion attributes to the character.

Manufacturing Costs: 22,000 sp; 2,200 xp; must know *summon beast* and have the Craft Major Magic Item feat.

MONSTERS OF KHET

Nomads report seeing strange lights at night around the ruins and claim a Lamia lives there. Occasionally one hears reports of encounters with strange, gnarled, blue-robed little people roaming around the ruins at night. Stygian river-horses and giant Stygian crocodiles (as well as all manner of serpents) live in the River Styx. Twenty-foot-long serpents, Sons of Set (see *Conan the Roleplaying Game* for statistics), still live in the ruins, although none know what sustenance these horrors find in the dark pits below Khet. For more information on the creatures found around Khet see *Conan: Stygia – Serpent of the South*.

KHET

Kuthchemes

THE TOMB OF THUGRA KHOTAN

KUTHCHEMES IS A mysterious black ruin of the days when Stygia ruled Shem and its borders ran alongside the borders of Acheron. The ruin is in the far south-eastern deserts of Shem. It is a week's ride south of the barren hills at the border of Koth and a few days camel-ride north-east of the bend in the River Styx.

HISTORY

Kuthchemes was the eastern citadel of the kingdom of the Giant-Kings before the Khari (proto-Stygians) arrived. It was a walled city that defended the Giant-Kings from nomadic raids. They built the city out of black stone and raised monumental structures in honour of Yig, Set and their own God-Kings. The Children of Set lived in the temples as advisors and objects of worship.

The Khari arrived and found the Giant-Kings had grown decadent and soft, utilising humans for its infrastructure. Kuthchemes was woefully under-defended and fell quickly to the organised and mighty army of the Khari. The Khari refortified the city and used it as a base of operations as they attacked the rest of the Giant-Kings' lands, conquering the line of cities along the River Styx. The Heart of Ahriman, at this time, was located in Kuthchemes and was captured by the Stygians. Kuthchemes was remade into a Stygian city boasting of a warrior-priestess caste as well as the regular Stygian castes.

The Hyborians destroyed Kuthchemes 500 years after the fall of Acheron when the Kothians pushed the Stygians south of the River Styx. While the Kothians were shattering the streets and cutting down its archers, Thugra Khotan, the last magician of Kuthchemes, swallowed a strange, terrible poison and his masked priests locked him in the tomb he had prepared for himself. The Kothians slaughtered the priests but could not harm the tomb by maul or by fire, so they left the city a ruin.

For 2,500 years the ruins of Kuthchemes slumbered under the desert sun, undisturbed... until recently.

LAYOUT

The city is built out of black piles of colossal masonry for the most part, although some buildings are

made of ivory or marble. A long dry river bed runs through the ruined city. The black ruins are colossal: broken columns of huge size; cyclopean blocks of broken black masonry and shattered remnants of massive statues. Tombs, temples, spires, obelisks, mausoleums, mansions and thin bridges of black stone fill the city area.

1. **Thugra Khotan's Tomb:** The tomb of Thugra Khotan is a towering ivory dome. The base of the tomb dominating Kuthchemes is a gigantic pedestal of marble rising from what had been a terraced eminence on the banks of the ancient river. Broad steps lead up to a great bronze door in the dome. The dome rests on the base like half of some titanic egg and is made of pure ivory. The ivory shines as if unknown hands continually keep it polished. The pinnacle of the dome but has a shiny, gold spire capping it, also eternally polished. Golden hieroglyphics are inscribed about the curve of the dome. No man on Earth can read those characters. It is obvious to even the most dim-witted of fools that there is something unnatural about the structure. The dome creates an Element of Horror (see page 23) in those approaching it.

He stood, the one atom of life amidst the colossal monuments of desolation and decay. Not even a vulture hung like a black dot in the vast blue vault of the sky that the sun glazed with its heat. On every hand rose the grim relics of another forgotten age: huge broken pillars, thrusting up their jagged pinnacles into the sky; images, whose horrific features the corroding winds and dust-storms had half erased. From horizon to horizon no sign of life: only the sheer breath-taking sweep of the naked desert, bisected by the wandering line of a long-dry river-course: in the midst of that vastness the glimmering fangs of the ruins, the columns standing up like broken masts of sunken ships - all dominated by the towering ivory dome before which Shevatas stood trembling.

Robert E. Howard, *Black Colossus*

KUTHCHEMES



- o **The Door of the Tomb:** The bronze door has a smooth surface and offers no bolt or catch. Only the most sensitive of fingers and the most skilled of thieves can discover the projections that no eye can see. If these are pressed carefully according to a peculiar system (found in the forbidden iron-bound books of Vathelos the Blind) while muttering a long-forgotten incantation (learned from the grisly whispers of the votaries of Skelos under midnight trees), then the door will retreat inward without sound, revealing a short, narrow corridor. The door slides down this corridor until it becomes fixed at the end. Anyone attempting to open the door without the correct method will suffer an Element of Madness (see page 23).

- o **The Hallway:** A short narrow corridor leads from the door of the tomb inward. The floor, ceiling and sides of the tunnel-like aperture are of ivory. Twenty-foot long serpents with iridescent scales slide through an opening on one side when the door is opened, drawn to the fresh air and the prospect of food from their dank pits beneath the tomb. Banging against the door of the tomb will cause the door to slide to the side and reveal the interior of the tomb.

- o **The Interior of the Dome:** A crimson light throbs and pulses, lighting the interior in a manner almost beyond the endurance of mortal eyes. The light comes from a gigantic red jewel high up in the vaulted arch of the dome. The treasure here is beyond mortal reckoning, covering the floor inches deep in gold dust and other fantastic treasures. In the centre of the chamber is a dais of crystal directly beneath the red jewel. The floor of the tomb is made of ivory.

- ☒ **The Body of Thugra Khotan:** If the campaign takes place before the story *Black Colossus*, then Thugra Khotan's body (not just his bones) lies in state within the ivory dome. Legends state that his bones are guarded by a serpent. If the tomb is entered, his mouldering mummy will awaken and attack any who enter the tomb. The mummy is gone if the campaign takes place after *Black Colossus*.

2. **The Great Hall:** This ruined hall is where the priest king of Kutchemes hacked off the heads of hundreds during festivals dedicated to Set. Thousands of columns and statues comprise the hall, which is almost entirely ruined and crumbled.

3. **Temple of Set:** A huge, black temple devoted to Set, the Serpent-God of Stygia, squats near the northern entrance. Great serpents live in pits beneath the temple.

4. **The Pit:** Near the great hall is a pit where human sacrifices were thrown screaming to a nameless

'But in the reign of Thugra Khotan, the last magician of Kutchemes, grey-eyed, tawny-haired barbarians in wolf skins and scale-mail had ridden from the north into the rich uplands to carve out the kingdom of Koth with their iron swords. They had stormed over Kutchemes like a tidal wave, washing the marble towers in blood, and the northern Stygian kingdom had gone down in fire and ruin.

Robert E. Howard, *Black Colossus*

amorphous monstrosity from Hell. The pit lies beneath a black dome held up by black columns.

5. **Dry River Bed:** The river that used to run through Kutchemes has long since dried up, leaving the ruined remains of docks, wharves and bridges. Two of the four bridges have collapsed. The city wall ran over the river, leaving a gate for the water to travel through. Along the banks of this ancient bed are the ruins of wharves and storehouses.
6. **Walk of Heroes:** Giant black statues of ancient Giant-King warriors line this ruined walk. Most of the statues have crumbled or fallen. The three that are still standing are so wind-scoured that they lack recognisable characteristics. Surrounding the Walk of Heroes are colossal and cyclopean mausoleums, the tombs of Giant-Kings and noble-born Stygians. Many of the tombs may contain large bowl sarcophagi containing buried Children of Set, who were worshipped as gods by the Giant-Kings of old.
7. **Market District:** This area is characterised by ruined squares, markets, monuments and columned buildings.
8. **Temple District:** The part of the city known for its temples include temples to Set, various demons and other monuments to gods older and darker than even the Old Serpent. Mausoleums to ancient sorcerers and old priests also litter the area. A lot of domes and spires characterise the architecture of this sector of Kutchemes.
9. **Mansions and Estates of the Nobles:** This is the quarter where most noble families had their estates. Lots of domes, columns and spires are evident in these large and elaborate edifices of black stone. This section is located just to the south of the Great Hall and the mausoleums of the Pit.
10. **Craft District:** This is the district of the craftsmen, filled with winding streets, short black houses and lots of columns. This area is totally ruined. There are few (if any) intact roofs – only the foundations and remnants of walls remain.
11. **City Walls:** Large and thick walls of black stone surround the city, although not all of them are still fully intact.

Square towers are set into the walls at regular intervals, except for the towers on the banks of the dry river-bed, which are round. There is a gate in the north and in the south. The towers on either side of the two gates and the four towers around the dry river bed have turrets. The walls have battlements and merlons.

LEGENDS

Great treasures are said to be found there, although none live to enjoy any that might be stolen.

Legends make Thugra Khotan more than human. His degraded votaries still mint coins with his image and place those coins under the tongues of the dead to pay for passage to the afterlife. These votaries are known as the Zugite cult.

Beneath the pit of the nameless monstrosity is a path that leads to the River of Darkness, forded by Charon-like ferryman-demons from myth (use Black Fiend stats from *Conan the Roleplaying Game* but arm them with scythes). The River of Darkness leads to the afterlife. Those who do not pay the ferryman will encounter shades of their past and future.

MAGIC & UNUSUAL ITEMS HIDDEN IN THE RUINS

The treasure of the tomb of Thugra Khotan is heaped in staggering profusion – piles of diamonds, sapphires, rubies, turquoises, opals, emeralds; ziggurats of jade, jet and lapis-lazuli; pyramids of gold wedges; teocallis of silver ingots; jewel-hilted swords in cloth-of-gold sheaths; golden helmets with coloured horsehair crests, or black and scarlet plumes; silver-scaled corselets; gem-crusted harness worn by warrior kings three thousand years in their tombs; goblets carved of single jewels; skulls plated with gold, with moonstones for eyes; necklaces of human teeth set with jewel. The ivory floor of the tomb is covered inches deep with gold dust.

As far as unusual items, one could probably find a *potion of hibernation* and *dust of forgetfulness*, both of which are detailed in *Conan: The Scrolls of Skelos*.

Many a thief sought to gain the treasure which fables said lay heaped about the mouldering bones inside the dome. And many a thief died at the door of the tomb, and many another was harried by monstrous dreams to die at last with the froth of madness on his lips.

Robert E. Howard, *Black Colossus*

MONSTERS & GUARDIANS OF KUTHCHEMES

Twenty-foot-long serpents, Sons of Set (see *Conan the Roleplaying Game* for statistics), still live in the ruins, although none know what sustenance these horrors find in the dark pits below Kuthchemes. There are also bowl sarcophagi which may contain the Children of Set (man-serpents) such as the one seen in *The God in the Bowl*. The statistics for Thugra Khotan first appeared in *Conan: The Scrolls of Skelos*; these statistics are an errata to those.

THE NAMELESS MONSTROSITY FROM HELL (ZUG, THE DWELLER BELOW)

Huge Outsider (demon)
Hit Dice: 20d8+300 (390 hp)
Initiative: +14 (+1 Dex, +13 Reflex)
Speed: 10 ft. (2 squares)
Dodge Defence: 19 (–2 size, –4 Dex, +15 natural)
DR: 10
Base Attack/Grapple: +20/+43
Attack: Tentacle +33 melee (2d6+15)
Full Attack: 8 tentacles +33 melee (2d6+15, 19–20, x2, AP 20) and bite +28 melee (2d8+7, 19–20, x2, AP 22)
Space/Reach: 15 ft. (3)/15 ft. (3)
Special Attacks: Corporeal instability, swallow whole
Special Qualities: Immunity to transformation, manifest
Power Points: 55 (base 50, +5 Wis)
Magic Attack Bonus: +15 (+10 natural, +5 Charisma)
Saves: Fort +27, Ref +13, Will +17
Abilities: Str 40, Dex 13, Con 40, Int 18, Wis 20, Cha 20
Skills: Balance +19, Climb +38, Craft (alchemy) +27, Craft (herbalism) +27, Intimidate +28, Jump +38, Knowledge (arcana) +27, Knowledge (religion) +27, Listen +28, Perform (ritual) +28, Spot +28
Feats: Power Attack, Cleave, Great Cleave, Improved Critical (tentacle), Improved Critical (bite), Improved Bull Rush, Improved Overrun
Environment: Any land and underground
Organisation: Solitary
Advancement: –

The horrific creature lurking in the Pit of Kuthchemes known as a monstrosity from Hell has a mutable, ever-changing form. Howard describes the creature as nameless but apocryphal sources give the demon the name Zug. He is large enough to appear as the



floor of the pit. He is green and has many green eyes. He attacks with squid-like feeding tentacles that he can form at will.

Combat

The nameless horror in the pit of Kuthchemes is always hungry. It can grow a huge maw in any part of its bulk and can extend up to eight squid-like feeding tentacles to grab prey. The feeding tentacles have sharp, barbed suckers to help it catch its prey and bring it to its tooth-filled maw.

Manifest (Su): As a standard action, the monstrosity from Hell can either leave Earth and return to its home place, or appear somewhere else on Earth. In either case, it manifests at the new location at the end of its action.

Alien Anatomy (Ex): The internal organs of this demon are so different from terrestrial life, with no recognisable rhyme or reason, that it is immune to critical hits.

Swallow Whole (Ex): If the monstrosity from Hell begins its turn with an opponent held in its mouth by making a grapple attack, it can attempt a new grapple check (as though attempting to pin the opponent). If

it succeeds, it swallows its prey, and the opponent takes bite damage. Unless otherwise noted, the opponent can be up to one size category smaller than the swallowing creature. A swallowed creature is considered to be grappled, while the creature that did the swallowing is not. A swallowed creature can try to cut its way free with any light slashing or piercing weapon (the amount of cutting damage required to get free is noted in the creature description), or it can just try to escape the grapple. The Defence Value of the interior of a creature that swallows whole is normally $10 + \frac{1}{2}$ its natural Defence bonus, with no modifiers for size or Dexterity. If the swallowed creature escapes the grapple, success puts it back in the attacker's mouth, where it may be bitten or swallowed again.

Corporeal Instability (Su): A blow from a monstrosity from Hell against a living creature can cause a terrible transformation. The creature must succeed on a Fortitude save (DC 15) or become a spongy, amorphous mass. Unless the victim manages to control the effect (see below), its shape melts, flows, writhes, and boils. The save DC is Constitution-based.

An affected creature is unable to hold or use any item. Clothing, armour, rings and helmets become useless. Large items worn or carried – armour, backpacks and even shirts – hamper more than help, reducing the victim's Dexterity score by 4. Soft or misshapen feet and legs reduce speed to 10 feet or one-quarter normal, whichever is less. Searing pain courses along the nerves, so strong that the victim cannot act coherently. The victim cannot cast spells or use magic items, and it attacks blindly, unable to distinguish friend from foe (-4 penalty on attack rolls and a 50% miss chance, regardless of the attack roll).

Each round the victim spends in an amorphous state causes 1 point of Wisdom drain from mental shock. If the victim's Wisdom score falls to 0, it becomes a *foaming blasphemy* (see page 145).

A victim can regain its own shape by taking a standard action to attempt a Charisma check (DC 15) (this check DC does not vary for a monstrosity from Hell with different Hit Dice or ability scores). A success re-establishes the creature's normal form for 1 day. On a failure, the victim can still repeat this check each round until successful. Corporeal instability is not a disease or a curse and so is hard to remove. A *warding* or *greater warding* spell removes the affliction.

Immunity to Transformation (Ex): No mortal magic can permanently affect or fix a monstrosity from Hell's form. Effects such as *awful rite of the were-beast* force the creature into a new shape, but at the start of its next turn it immediately returns to its mutable form as a free action.

THUGRA KHOTAN (NATOHK THE VEILED ONE)

Scholar 17

Medium Humanoid (Stygian)

Hit Dice: 10d6+10 plus 7 (52 hp)

Initiative: +13 (+4 Dex, +9 Reflex)

Speed: 30 ft. (6 squares)

Dodge Defence: 20 (+6 level, +4 Dex)

Parry Defence: 17 (+6 level, +1 Str)

DR: –

Base Attack Bonus/Grapple: +12/+13

Attack: Unarmed strike +16 melee finesse (1d4+1) or thrown flame-powder +16 ranged (1d4 fire)

Full Attack: Unarmed strike +16/+11/+6 melee finesse (1d4+1) or thrown flame-powder +16/+11/+6 ranged (1d4 fire)

Special Attacks: Sorcery

Special Qualities: +4 Power Points, advanced spells x15, base Power Points, bonus spells x3, increased maximum Power Points (quadruple), knowledge is power, lay priest background, new sorcery style x6, scholar, Stygian qualities

Space/Reach: 5 ft. (1)/5 ft. (1)

Saves: Fort +6, Ref +9, Will +15 (+3 vs. Corruption)

Abilities: Str 13, Dex 18, Con 12, Int 17, Wis 16, Cha 19

Skills: Bluff +16, Concentration +21, Craft (alchemy) +23, Craft (herbalism) +23, Decipher Script +20, Handle Animal +6, Intimidate +24, Knowledge (arcana) +23, Knowledge (history) +23, Knowledge (religion) +23, Listen +8, Perform (harp) +20, Perform (ritual) +19, Spot +15

Feats: Alertness, Improved Grapple, Improved Unarmed Strike, Iron Will, Leadership, Loathsome Weapon, Poison Use, Priest, Ritual Sacrifice, Tortured Sacrifice

Reputation: 125 (Villain) (He may add a +10 bonus to his Bluff, Intimidate and Gather Information checks).

Leadership: 21/30 (10th level cohort; 800 1st level, 50 2nd level, 13 3rd level, 5 4th level, 2 5th level, 1 6th level followers)

Code of Honour: None

Allegiances: None

Magic Attack Bonus: +12 (+8 level, +4 Cha)

Power Points: 8 (4 base, +3 Wis, +4 bonus, –3 obsession penalty for Yasmela; 32 maximum)

Power Points (after acquiring Yasmela): 14 (4 base, +3 Wis, +4 bonus, +3 obsession bonus for Yasmela; 56 maximum)

Sorcery Styles Known: Counterspells, Divinations, Hypnotism, Immortality, Necromancy, Summonings

Spells Known: *Agonising doom, astrological prediction, banish outsider, bind demon, death touch, demonic pact, domination, dread serpent, entrance, eternal youth, form demon, greater demonic pact, greater warding, hypnotic suggestion, illusion, master warding, mind-reading, projection, raise corpse, summon demon, summon elemental, visions, warding, witch's vigour*

Corruption: 10

Obsession: Princess Yasmela of Khoraja

Possessions: Silk robes, ebon staff of Set, 20 doses of flame-powder, 3-stringed harp, potion of hibernation, dust of forgetfulness



Thugra Khotan was the last magician of Kutchemes when it fell approximately 2,500 years ago; he is a wizard of Old Stygia and he put himself into hibernation as Kutchemes fell. He arose from his millennia-long sleep recently as Natohk the Veiled One during the events of *Black Colossus*. He is a mysterious desert sorcerer of unnatural height and terrifying aspect, always appearing cloaked and veiled. He welded together a dangerous force of Asshuri Shemites, savages of Kush and rebel nobles of Stygia to menace Khoraja and eastern Koth. None knew from whence he came, though persistent rumours hinted that he came out of the desert on a demonic, cloven-hoofed black camel all wreathed about with fire.

Thugra Khotan, in his previous life, had a fine facial bone structure and a healthy head of hair. Most depictions of him as Natohk the Veiled One is one of Corruption, his face and body taking on mummy-like textures. He is an active sorcerer, is noted for his excellent muscular coordination and, even after nearly 3,000 years, still has energetic lustful yearnings. Thugra Khotan avoids salt and liquor if he can, and prefers quiet, serene surroundings.

Although he generally lacks any sense of tact or diplomacy (which is why he has no ranks in Diplomacy or Gather Information), he is charismatic enough with his innate expression of contagious enthusiasm

to gain a following regardless. He has the ability to inspire confidence in others.

Thugra Khotan is willing to gamble in order to follow a dream. He always follows his goals with an obsessive air, chasing his dreams with relentless energy and unlimited enthusiasm. At the time of his awakening, he was already obsessed with possessing Yasmela of Khoraja. If he does not yet possess her, he suffers a -3 obsession penalty to his Power Points (see *Conan the Roleplaying Game* for rules on obsession). Once he has her, the penalty becomes a bonus; he intends to feast upon her soul.

When encountered by Conan, Thugra Khotan (as Natohk) has a *greater demonic pact* with a demon lord who has sent him an uncanny steed and a black fiend that gibbers in the night to serve him. However, neither of these creatures is especially loyal to him; both will flee if he has clearly lost favour with his demonic overlord, such as his army losing badly in battle.

Thugra Khotan's cohort is a rebel Stygian prince named Kutamun. Thugra Khotan's followers are Stygian soldiers and nobles. By virtue of his wealth and intimidating nature, he has also been able to recruit some 2,000 Kushite light cavalry and 5,000 *asshuri* out of the Meadow Cities in western Shem. Thugra Khotan also has thousands of nomad warriors at his service. He may have upwards around 100,000 warriors in total. He led this force against Shem and drenched their walls in blood and killed their kings in front of the altars to their gods.



Pteion the Damned

INHUMAN REMINDER OF ANCIENT TIMES

PTEION IS A ruin from ancient times in eastern Stygia across from the Taian border.

HISTORY

Chronicles declare it was founded by the Giant-Kings thousands of years ago but legends say it was founded by the serpent men of prehistoric Valusia. The city was built on the edge of a sluggish river created by the Cataclysm.

For 500 years, Pteion was the seat of black magicians, a place of absolute terror. The Giant-Kings and their half-human offspring practised the worst of their fell sorcery here, learning from ancient, unknowable sources that slithered beneath the city, speaking to abominations in black pits deep beneath the dark buildings of their unseemly city.

Then, during the Seventh Dynasty, the lesser cataclysm struck and re-routed the River Nilus, leaving the city alone in the desert without fertile soil to sustain it. When the river shifted its course, the magicians moved the centre of their power to Khemi.

For generations afterward, the city was used as a necropolis. Thousands of years later, when the Khari came sweeping out of the east to lay waste to the civilisation of the Giant Kings, the city was lost and forgotten, left for the desert to consume.

LAYOUT

Drifts of sand pile nearly to the top of the remains of the outer walls. Some of the walls have crumbled. Black stone masses have a hint of the inhuman in their structure. They are low and narrow with sides slanting at curious angles to roofs grotesquely decorated. Monoliths and twisted columns rise above the sands. The streets twist and intertwine in maddening chaos amid cockscomb roofs, stumps of pillars and statues eroded to shapelessness. Drifting dust covers everything. Most buildings are collapsed to rubble heaps.

A. In the middle of the city on a large square looms a dolmen, a prehistoric tomb made of black megaliths set into formation, built of polished ebon slabs so huge that no man could tell how they had been raised into place. The dolmen

was probably once covered with dirt but time has blown all of that away, leaving only the skeleton of black megaliths behind. The megaliths of the dolmen tower 60 feet high and easily weigh 340 tons each on average. The floor of the dolmen is paved with black stones and the ceiling is usually lost in the darkness. At one end, a dim, bluish light can be discerned. Wings whisper and scales slither all around, although naught can be seen. The blue light comes from a crystal globe nested on a great block that serves as an altar. The block is inscribed with symbols that takes the eye down impossible paths and evoke nightmarish visions. Behind the altar looms an idol of something winged and many-tentacled, a god older than Set. At the edge of the blue illumination is an engraving of an ankh on the man-sized stone paving of the floor. This is the lid of an immemorial grave (if *Conan the Rebel* is taken as canon for your campaign, and the Player Characters are visiting Pteion after Conan's visit, this lid has been smashed to bits). Inside the grave are a few bones and traces of grave goods. Also, this is the hiding place of the magical Ax of Varanghi.

B. Toward the centre of the city is a stately avenue that belonged to the wealthy. The rubble of mansions that formerly stood well back from the avenue sloped in windrows to the feet of a double row of tall black menhirs that still line the avenue. Millennia of sandstorms have scoured off most of the hieroglyphs chiselled into their sides. Each one is approximately 50 feet tall and weighs 330 tons on average. The avenue leads to the dolmen.

C. The house of the skull has a huge black gate with a time-blurred but recognisable outsized human skull carved in the stone above it. The ghouls live in this house.

LEGENDS

Legend claims most of the city is underground, serpentine labyrinths fit for the snake-men who possibly built the city later inherited by the Giant-Kings and the forebears of the Acheronians.

Tombs of the snake-men, the serpents-that-speak, can be found beneath the ruins amid those labyrinths. Their magic (what was not plundered by the Giant-Kings) may still exist in unopened tombs.

PTEION

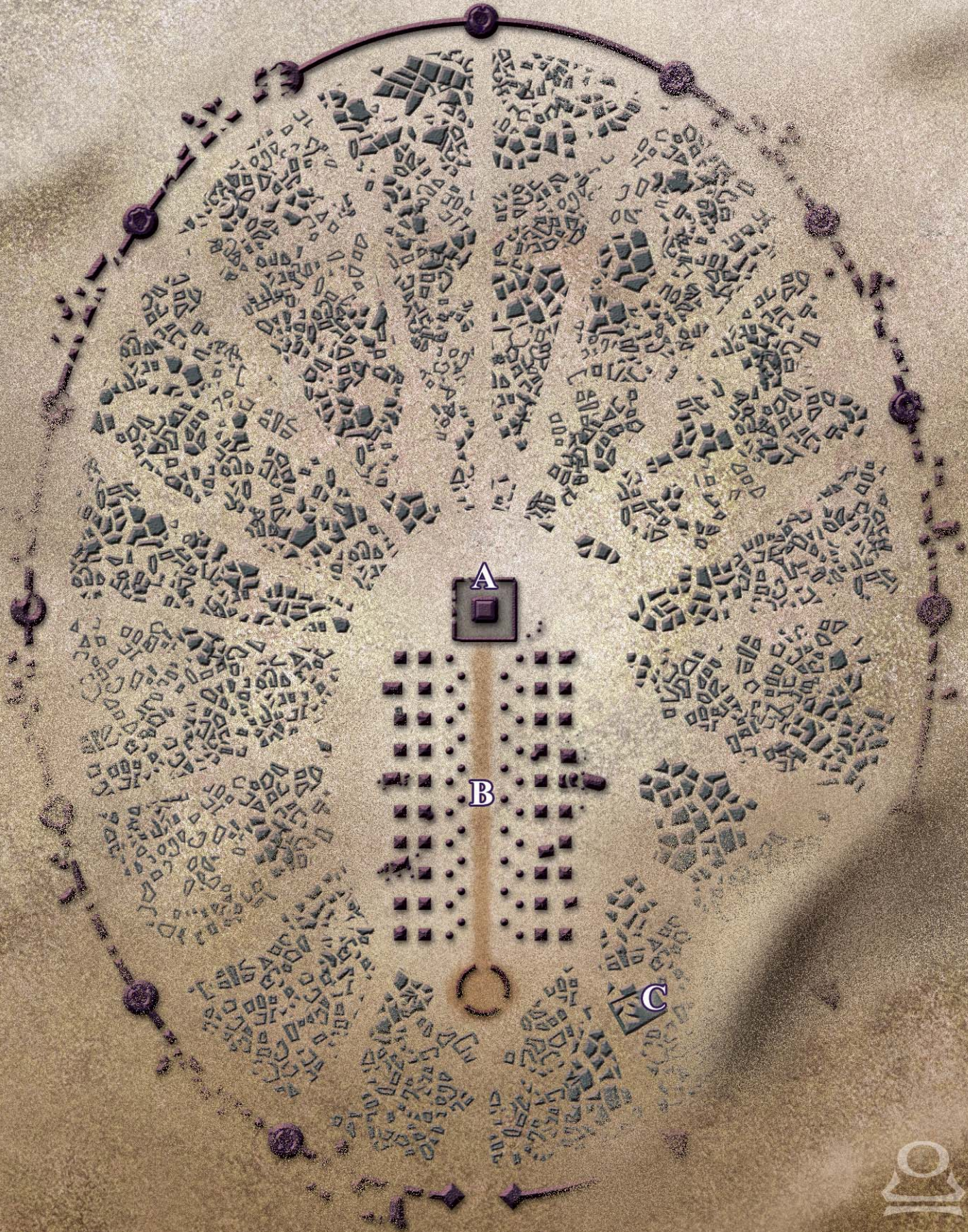

MAGIC & UNUSUAL ITEMS IN THE RUINS

It is said to be the resting place of the Ax of Varanghi, a powerful artefact of antiquity.

AX OF VARANGHI

This is a powerful magical weapon, one that comes alive in the hands, becoming part of the wielder, making the warrior a war god. The ax is razor keen and never needs honing. It serves a being older than Set, something winged and many-tentacled. The battle ax is such as is used in Taia, long and straight, with a slightly curved edge. The hammer-side of the axe is a sharpened point. It is a large weapon, requiring someone of 16 Strength or better to swing it proficiently. The helve of the weapon is made of an unknown red-brown wood that does not decay with age. Etched into the side of the ax-head is the emblem of the sun. The ax shines with a blue-white shimmer and wards off magic, so divination spells cannot find it and prestidigitation spells cannot move it. Spells cast at the wielder of this Ax rebound against the caster. Anyone with even a single point of Corruption that dares to pick up the ax will be put into a coma for 1d12 weeks. The weapon can affect a creature that has immunity to physical damage and it offers a +1 bonus to attack rolls (+2 if the wielder has a code of honour). It does 1d12 base damage, has a x3 critical, armour piercing of 9, 20 hardness and 30 hit points.

Manufacturing Costs: 130,000 sp; 13,000 xp; caster level 17th; spells required *agonising doom*, *warding*, *greater warding*.

MONSTERS & GUARDIANS OF PTEION THE DAMNED

The city is defended by 200 or so dried corpses, the blackened natural mummies of the dead. Once inside its walls, ghouls (see the entry on ghouls in *Conan the Roleplaying Game* or the ghouls on page 96) lurk within. Giant hyenas the size of bulls and clawed, bipedal dinosaurs twice the height of a man are also said to haunt the interior. Some believe these monsters are kept in an enchanted sleep until such time as the ruin is entered; others believe they hunt the surrounding dunes for sustenance and simply nest in Pteion. The foul beings raised up by the ancient wizards still haunt the area.

THE DEAD OF PTEION

Medium Undead

Hit Dice: 3d12+3 (22 hp)

Initiative: -1 (-1 Dex)

Speed: 20 ft. (4 squares)

Dodge Defence: 10 (-1 Dex, +1 natural)

Base Attack/Grapple: +1/+4

Attack: Unarmed +4 (1d6+3)

Full Attack: Unarmed +4 (1d6+3)

Space/Reach: 5 ft. (1)/5 ft. (1)

Special Attacks: -

Special Qualities: Ambulatory limbs, limp stumble, undead traits

Saves: Fort +1, Ref +0, Will +3



Those were not living men, they were dried corpses. Some bore archaic helmets and cuirasses over blackened skin, most wore only cerements gone ragged during millennia. In many, bones jutted through desiccated flesh. The sunken faces were unstimring, empty of expression: what eyes remained were dull, tearless, unwinking; breasts drew no breath, hearts did not beat behind ribs. Legs moved puppetlike. The company was armed with shortswords of antique shape or spears whose heads flared in the same fashion. The metal was corroded green bronze. The bodies numbered two hundred or more. The shuffle of their feet was the single sound they made.

Poul Anderson, *Conan the Rebel*

Abilities: Str 17, Dex 8, Con –, Int –, Wis 10, Cha 1

Skills: –

Feats: Brawl, Toughness

Climate/Terrain: Any land and underground

Organization: Gang (2-5), squad (6-10) or mob (11-20)

Advancement: 4-5 HD (Medium)

The risen dead plague many of the ruins and dark places of Hyboria. They are dried corpses in ancient armour.

Combat

The dead of Pteion fight with bronze short swords or spears of antique shape. The dried, black mummies of Pteion are not stopped by the loss of heads, arms or any other critical damage. Dismembered pieces continue to jerk and attack if possible.

Limp Stumble: The dead of Pteion are highly ineffective in combat and indeed everything else. All that they do is characterised by slowness, clumsiness and brainlessness. Each *round*, they may take either a standard action or a move action but not both.

Ambulatory Limbs (Su): The dead of Pteion are immune to critical hits; however, if a critical hit is confirmed, the dead loses a limb (although it just takes regular damage). On a roll of 1-4 on a d20, it loses its left leg; On a roll of 5-8 on a d20, it loses its right leg; On a roll of 9-12 on a d20, it loses its left arm; On a roll of 12-16 on a d20, it loses its right arm; On a roll of 17-20 on a d20, it loses its head.

GHOUL OF PTEION

Medium Monstrous Humanoid

Hit Dice: 6d8+12 (39 hp)

Initiative: +9 (+2 Dex, +7 Reflex)

Speed: 40 ft.

Dodge Defence: 16 (+2 Dex, +4 natural)

DR: 2

Base Attack/Grapple: +6/+9

Attack: Claw +9 melee (1d4+3)

Full Attack: 2 claws +9 melee (1d4+3), bite +7 melee (1d8+1, AP 4)

Space/Reach: 5 ft. by 5 ft. (1)/5 ft. (1)

Special Attacks: Improved grab, relentless jaws, infective touch

Saves: Fort +6, Ref +7, Will +2

Abilities: Str 16, Dex 14, Con 13, Int 10, Wis 10, Cha 1

Skills: Hide +13, Listen +5, Move Silently +13, Spot +5

Feats: Multiattack, Power Attack, Toughness

Climate/Terrain: Any land

Organization: Solitary, patrol (2-4), or gang (5-20).

Advancement: By character class (favoured class: barbarian)

Ghouls are misshapen, grey humanoids of enormous strength and vitality. They have inhumanly long arms that end in great claws. The ghoul lives in necropolises and dead cities.

Ghouls speak their own language of grunts, howls and screams. No non-ghoul has yet mastered it, largely due to the near-impossibility of dealing peacefully with these primal horrors.

Combat

Ghouls usually attack in a wild frenzy of claws and teeth, though against a more powerful foe they will use more careful hit-and-run tactics.

They pululated forth like maggots from rotting flesh till they formed a line three or four deep across the way. Conan's throat constricted, and a cold crawling passed over him. The naked, gray-skinned forms were manlike, in a skeletal fashion, but inhumanly long arms ended in great claws, and many squatted on all fours as jackals might while digging up a grave. Bestial too were the hairless heads, point-eared, muzzled, fanged, with eyes aglow like the eyes of owls. They leered, gibbered, let black tongues hang out, pawed the sand, crouched waiting.

Poul Anderson, *Conan the Rebel*

Improved Grab (Ex): To use this ability, the ghoul must hit with a bite. If it gets a hold, it can use its Relentless Jaws attack the following round.

Relentless Jaws (Ex): Once a ghoul has hold of an opponent in its jaws (see Improved Grab, above) it can continue biting him each round thereafter, dealing standard bite damage. This also gradually chews through its opponent's armour – each round the ghoul uses Relentless Jaws, including the first round, the AP rating of its bite increases by +1.

Infective Touch (Ex): A character wounded by a these creatures must make a Fortitude save (DC 13) at the end of the battle. Success indicates that the character fights off the infection. If the character fails the save, he sickens over the next 1d4 days, suffering 1 point of temporary Strength damage at the end of that time.

Skills: Ghouls have a +2 racial bonus to their Hide and Move Silently skills.

GIANT HYENA

Large Animal

Hit Dice: 5d8+20 (42 hp)

Initiative: +6 (+1 Dex, +5 Reflex)

Speed: 60 ft. (12 squares)

Dodge Defence: 13 (-1 size, +1 Dex, +3 natural)

Damage Reduction: 4

Base Attack/Grapple: +3/+15

Attack: Bite +10 melee (2d6+12, AP 9)

Full Attack: Bite +10 melee (2d6+12, AP 9)

Space/Reach: 10 ft. (2)/5 ft. (1)

Special Attacks: Trip

Special Qualities: Low-light vision, scent

Saves: Fort +8, Ref +5, Will +2

Abilities: Str 26, Dex 13, Con 19, Int 3, Wis 12, Cha 6

Skills: Hide +0*, Listen +7, Spot +5

Feats: Alertness, Track

Climate/Terrain: Warm desert and jungle

Organization: Solitary, pair or pack (40-50)

Advancement: 6-7 HD (Large)

*Hyenas have a +4 racial bonus on Hide checks in areas of tall grass or heavy undergrowth.

Hyenas are pack hunters infamous for their cunning and their unnerving vocalizations. Pteion's giant hyenas are the size of a bull.

Combat

A favourite tactic is to send a few individuals against the foe's front while the rest of the pack circles and attacks from the flanks or rear.

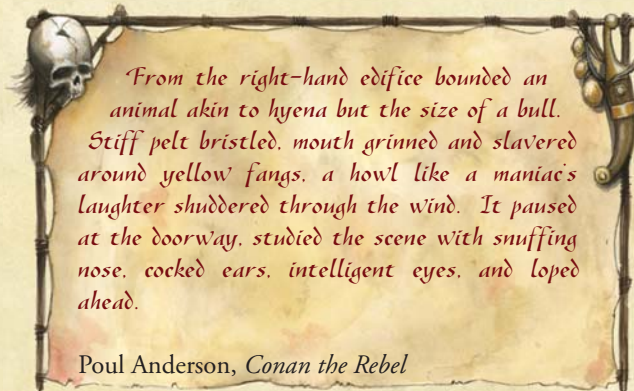

From the right-hand edifice bounded an animal akin to hyena but the size of a bull. Stiff pelt bristled, mouth grinned and slavered around yellow fangs, a howl like a maniac's laughter shuddered through the wind. It paused at the doorway, studied the scene with snuffing nose, cocked ears, intelligent eyes, and loped ahead.

Poul Anderson, *Conan the Rebel*

Trip (Ex): A hyena that hits with its bite attack can attempt to trip the opponent (+2 check modifier) as a free action without making a touch attack or provoking an attack of opportunity. If the attempt fails, the opponent cannot react to trip the hyena.

SAURIAN OF PTEION

Huge Animal

Hit Dice: 8d8+48 (84 hp)

Initiative: +10 (+2 Dex, +8 Reflex)

Speed: 60 ft. (12 squares)

Dodge Defence: 16 (-2 size, +2 Dex, +6 natural)

Base Attack/Grapple: +6/+19

Attack: Talons +9 melee (2d8+5)

Full Attack: Talons +9 melee (2d8+5) and 2 foreclaws +4 melee (1d4+2) and bite +4 melee (2d6+2)

Space/Reach: 15 ft. (3)/10 ft. (2)

Special Attacks: Pounce

Special Qualities: Low-light vision, scent

Saves: Fort +11, Ref +8, Will +4

Abilities: Str 21, Dex 15, Con 21, Int 2, Wis 15, Cha 10

Skills: Hide +5, Jump +27, Listen +12, Spot +12, Survival +12

Feats: Run, Toughness, Track

Environment: Warm forests

Organization: Solitary, pair or pack (3-6)

Advancement: 9-16 HD (Huge); 17-24 HD (Gargantuan)

This creature is a larger version of the deinonychus, standing about 12 feet tall with a total length of 24 feet. It has a sickle-shaped toe-claw on its second toe (of four) that it can slash forward to disembowel prey. A carnivore, it has a curved, flexible neck on which is mounted with a large, reptilian head with serrated teeth. Its long tail is rigid and club-like; it uses this for balance and turning ability.

Combat

The saurian pounces upon prey, slashing with its sickle-claws and biting with its teeth. It often tries to grapple with its claws,

From the left-hand structure stalked a beast on two long, taloned legs. Though the body stooped forward, counterbalanced by a great cudgel of a tail, the blunt reptile head lifted twice a man's height. Small forelimbs were bent, claws laid together in a parody of prayer. Scales on back and sides sheened steel-gray through dimness; the belly sagged white. When it saw prey, the saurian hissed and hastened.

Poul Anderson, *Conan the Rebel*

holding prey down so it can bite it more easily. Other times it grapples with its bite, holding tightly onto prey with its powerful jaws, while slashing with its hind legs in attempts to disembowel the prey.

Pounce (Ex): If the saurian charges, it can make a full attack.

Skills: The saurian has a +8 racial bonus on Hide, Jump, Listen, Spot and Survival checks.

OTHER DANGERS

Pteion is deep in a sandy desert so sandstorms are always a danger for those travelling to or within the ruins.

SANDSTORMS

A sandstorm reduces visibility to 1d10×5 feet and provides a -4 penalty on Listen, Search, and Spot checks. A sandstorm deals 1d3 points of nonlethal damage per hour to any creatures caught in the open, and leaves a thin coating of sand in its wake. Driving sand creeps in through all but the most secure seals and seams, to chafe skin and contaminate carried gear.



Tombs & Pyramids

THE EVERLASTING HOUSES OF STYGIA

TOMBS AND PYRAMIDS

JACKALS TEND TO lurk around tombs and graves, which gave early Stygians (and probably the early Giant-King race) reasons to embalm the dead and build elaborate tombs. The poor are either buried in family mastabas, mass mastabas (for the followers and workers of the wealthy) or simply in mass graves. When adventuring in these tombs, there are no sources of natural light. Also, in keeping with the atmosphere of the Hyborian Age, there are also no sources of magical light (the Stygians did not use the green stones found in Xuchotl, for example, in their tomb-building).

The bodies of the poor are salted and laid to rest in the sand to a depth of three or four feet, usually without coverings or ornaments, often without even a coffin. The extremely poor may even dispense with the salting of the body, trusting to the desert dryness to preserve the body. Some poor arrange to be buried with the wealthy, promising to serve as bodyguards or servants for all eternity in order to achieve something better in the afterlife than a shallow grave.

However, the wealthy like to ensure a certain comfort in their afterlife, so they have themselves interred within tombs, having them built during their lives (as one can never be sure their families will spend the money to have one built for them). There are several types of tombs; the basic types, in ascending order of cost, are the mastabas, the rock-cut tombs and pyramid tombs. Even within those three types there are different levels of complexity and style. Mastabas can be basic or complex. Rock cut tombs can be short and simple or elongated and complex. Pyramids can be a few dozen feet high or they can tower over the landscape as a testament to the wealth and power of the king who built them.

ARTWORK

A common feature in most Stygian tombs is artwork. Artwork is of three types; the first is biographical artwork, depicting the life and times of the deceased and all of his roles and functions in society. The second type of artwork is sepulchral, relating to the funeral procession and the afterlife, providing texts so that the deceased can have an easier time in the next world. The third type of artwork relates to funereal gifts so the deceased has plenty to eat and drink in the afterlife. Virtually all writing is done in hieroglyphics. Chapters from the Book of the Dead, which teach the deceased how to do things in their *ka*-form, are often inscribed on the walls.

STATUES

Tombs are often filled with figures of animals, birds and reptiles, as well as statues of the gods and statues of the deceased, his family and the king. Statues of animals are often found as votive statues, amulets worn by the dead and funerary statues. In tombs, the statues are made of bronze, stone and/or wood. Amulets are made of faience, lapis-lazuli and other precious stones or metals. Common statues of animals include apes (especially baboons), hippopotami, cows, lions, sphinxes, bulls, rams, cats, jackals, hares, sows, stags, shrews, crocodiles, vultures, hawks, frogs, fish and scarabs. Statues and emblems of virtually all the gods can be found throughout the tomb. Many are grotesque by Hyborian standards, half-men and half-beast. One of the strangest is a mysterious woman called a Serq, who has the head and arms of a woman, but the body of a scorpion – but she has no legs, scorpion or otherwise. Most tombs have at least one statue of the king who was ruling at the time the deceased lived or who ruled when the deceased died.

SAMPLE TOMBS

The samples given here are primarily for inspiration, although they can serve well enough in a pinch. No two Stygian tombs are exactly alike, so feel free to mix and match and make changes to the samples here to make each tomb unique and interesting.

MASTABAS

Mastabas are solid mounds, usually made of stone rubble covered with a facing of levelled and smoothed black limestone blocks. In all, they look like the first tier of a step-pyramid. They are built to represent the rise of the first ground out of the sea of chaos from which all creation came. These are not just tombs but complete funerary chapels where the living can take care of the statues of the dead to make sure the dead have a pleasant life in the after world.

They are built in huge necropolises outside of the cities, all lined up in imposing order, much like a miniature city itself. The outsides of the mastabas are tall and decorated in the grotesque designs of their bestial half-human gods. Most of the interior rooms are decorated from floor to ceiling in drawings,

MASTABA WITH FOUR SERDABS

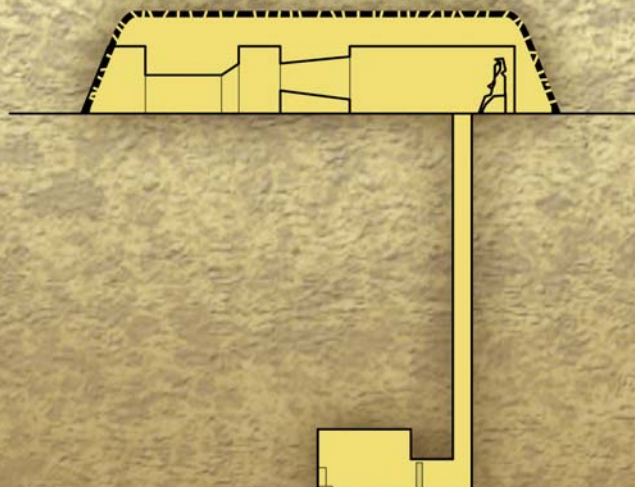
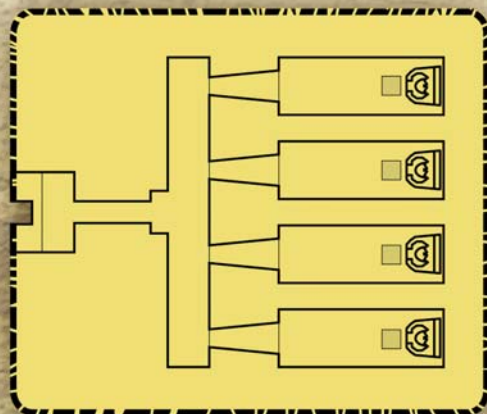

pictographs and hieroglyphs. Three samples are given. The first is the most basic, the second is more impressive and for a wealthier patron than the third, which is still more complex than the first.

In the basic mastaba tomb, there is an entry chamber that leads to a viewing hall. This viewing hall has sacrificial tables for food offerings or animal mummies. Also in the viewing hall there are small windows to look into the serdâb. The windows are about six inches wide and six inches high in the viewing room; they expand to a one foot height (retaining the six inch width) by the time it opens into the serdâb. Beneath the window is a stele naming the deceased.

There may be anywhere from one to six serdâbs in a mastaba. The sample map shows one with four serdâbs. A serdâb is a chamber for the deceased's *ka*. The serdâb contains a statue of the deceased which can be seen through the window. The serdâb usually has a small shaft somewhere in it to allow light in. In each serdâb is a shaft leading down to the sarcophagus chamber. The squared shaft is usually about two or three feet to a side and anywhere from 60 to a hundred feet deep. Another stele at the base of the shaft seals the actual burial chamber, which has the sarcophagus and the mummy within.

Mastabas can be more complex than the more common variety. These are the tombs of the priests and the officials, those who cannot afford to be lain in the pyramid tombs. The first sample complex mastaba is entered through a thin, tall doorway situated between two colossal statues. This is the mastaba of a vizier or a powerful high priest, even a deceased former Speaker of Set. The great sorcerer Rammon is buried in a tomb such as this.

1. On each side of the entry hall are images of the deceased and smaller images of his spouse, along with at least four rows of hieroglyphs giving the deceased's name and all of his titles. All the

images are in sunken relief. Designs showing the cycles of life fill out the rest of the entry hall. The actual first chamber is the vestibule, where the deceased is shown hunting in the swamp, which is filled with all sorts of swamp animals, to symbolically keep chaos away from the dead; the swamp represents primordial chaos and the hunt shows order being brought to the swamp.

2. This chamber shows the deceased hunting animals to protect the tomb and the deceased from ill-fortune. An altar is provided here for the sacrifice of such animals by the living. A statue of Bast is against the south wall.
3. This chamber depicts the deceased eating on his estates and being assisted by his servants and labourers. This room provides food for the deceased, both in the form of

STYGIAN COMPLEX MASTABA

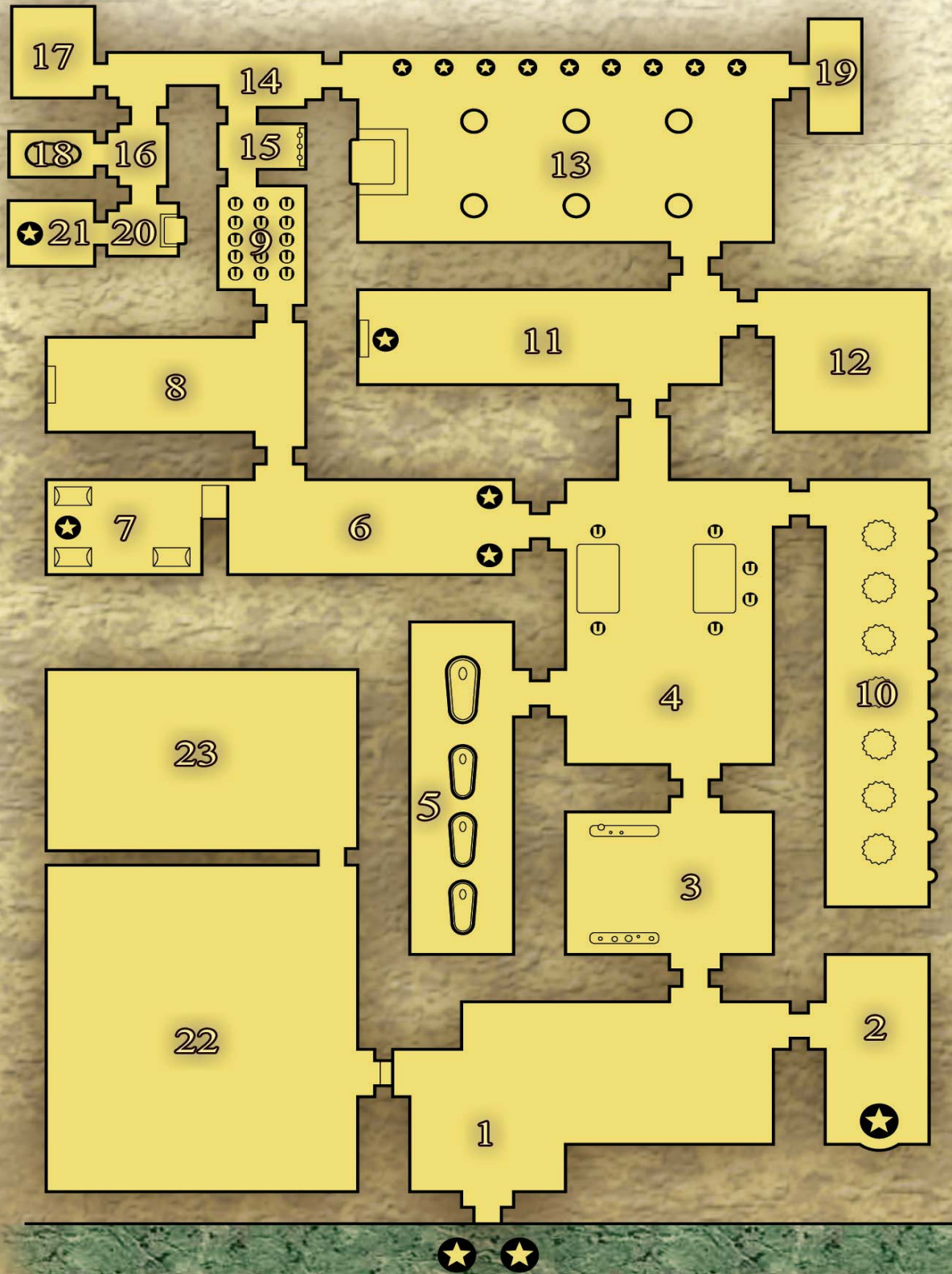

Sarcophagus



Statue



Ushabtiu

- the drawings on the walls and in food offerings brought by his cult or family.
4. The drawings on these walls show other activities done on the estate of the deceased, including (but not limited to) the actions of artisans, scribes, labourers and family. They are shown working and they are shown punishing those who do not work. This is to ensure his estates are taken care of in the afterlife. Low tables in this chamber often have ushabtiu figures performing work similar to those shown on the walls.
 5. This chamber holds the tombs of the deceased's wife (or wives) and any dead children or relatives. The tombs are reached through a series of shafts in the floor dropping 20 feet or more to the actual burial chambers and sarcophagi. Burials are given here for any relatives that might die after the deceased but may not be able to afford their own tombs.
 6. This chamber has statues of the deceased and his wife one either side of the passage leading from Chamber 4 as if they were walking from Chamber 4 into Chamber 6. Huge drawings of the deceased, surrounded by smaller figures of his wife, children and attendants, are on the west wall, watching the statues enter the room. Along the north and south walls are depicted long lines of attendants bringing the deceased and his family the fruits and products of his estate. Scribes are shown as recording the gifts. Long lines of fattened animals are shown in beautiful relief, many shown in the act of being sacrificed or butchered. Naked men on papyrus boats are shown hauling in fish.
 7. This serdâb is often sealed off. Sometimes a small shaft leads to the serdâb that is barely big enough for a hand. This shaft is so incense can pass into the serdâb for the pleasure of the *ka*. It holds statues of the deceased and furnishings. Other times it holds forbidden tomes or ancient treasures. Sometimes it holds a bowl sarcophagus with a family 'god' in it. Sometimes it holds a shaft to a sarcophagus chamber much like a basic mastaba.
 8. This chamber has the Book of the Dead carved on it. On the west wall is a stele used as a false door, a symbolic path to the after world. Furniture of the deceased is usually placed in this room.
 9. This chamber is filled with representations of servants, ushabtiu figures great and small line the floor in perfect rows, all with appropriate tools and implements for their chores.
 10. This chamber holds a whole procession of bestial and shambling gods with small altars for living sacrifices. The floors are usually blood-stained and black candles can be found inset within small niches in the walls, candles that, when lit, release a black light that make the hieroglyphs and pictures glow with an inhuman intensity. Just entering this room, unless one has at least one point of Corruption, is cause for a Terror check (DC 18).
- If the candles are lit, the Terror check is at a DC of 25. Ghosts and other horrible things often lurk in this chamber. In the mastaba of the sorcerer Rammon, for example, there are great pits in the floor where Foaming Blasphemies are kept, drumming and piping their mad tunes for eternity. Other sorcerers have similar trappings.
11. This chamber is an important room. It contains a shaft leading to the actual burial chamber of the deceased, which is built below this chamber. On the west wall is an inset false door, a symbolic path to the after world. A statue of the deceased is built stepping out of that inset into the room onto a small staircase. On the north wall, the deceased is shown overlooking the vast gifts of the king he was given in life, including vineyards and fields.
 12. This chamber portrays games and dances, probably by the children of the deceased, for the deceased is portrayed as a large figure watching them. The nude characters play board games, sports and dances. Often, the games of the deceased are placed in this room.
 13. This chamber is where the actual funeral would have been held. Great sacrifices would have been made here at the time of the burial and whenever favours were desired of the deceased. Six great pillars designed like papyrus stalks fill the chamber. Great statues of funerary gods (and Set) line the walls, inset within the hieroglyphs and orgiastic-drawings on the walls. A black and bloody altar to Set is against the west wall here.
 14. This is a small entry hallway into the tombs of the servants that were killed and buried with the deceased. It has a low ceiling, usually between four and five feet.
 15. This is a room where people can make offerings to the dead servants to keep their memories and names alive, lest they vanish from the afterlife and stop serving the deceased.
 16. This room has paintings of the tools necessary for the servants to do their jobs as well as written instructions. It has a low ceiling, usually between four and five feet.
 17. This is a mass tomb for soldiers to serve the deceased as protectors and bodyguards.
 18. This is a tomb for one of the servant overseers. It has a low ceiling and the sarcophagus is usually well-made.
 19. This is a tomb for mummified animals left for the deceased. An eerie ape-god looms at the east end of the room, looking over the animal mummies, wearing a crown with a mummified vulture-head on it.
 20. This chamber has a black altar with a bestial god looking over it, facing the statue of Set in Chamber 21.
 21. This chamber with a high ceiling houses a statue of Set. The hieroglyphs depict all the titles of Set and the proper way to greet and speak to the great Father Serpent.
 22. This chamber is usually sealed off and is not part of the funerary chapel of the deceased. This room has a low ceiling, about three to four feet high and is filled with

the corpses of the sacrifices killed when the deceased was buried. After the funeral the room is ceremoniously sealed.

23. This is where all the animals sacrificed during the funeral were laid to rest.

This mastaba is not as elaborate as the previous example. It is still elaborately decorated but has far fewer rooms.

1. A deep stairway leads into the tomb beneath the solid mastaba building. Other than the steps, this hall conforms to format in the previous mastaba for Room 1 in terms of decoration and symbolic purpose.
2. This chamber combines Areas 2, 3 and 4 from the previous mastaba example into one long hallway to protect the deceased, who is pictured in boats hunting or pictured sitting and eating or watching others hunting for him. A statue of Sobek lurks in one dark corner of the chamber. Mummified animals and food offerings

are often left here for the benefit of the deceased. The paintings on the walls indicate the deceased is surrounded by thousands of loaves of breads and other food stuffs. The incantations are meant to be read aloud by those entering the tombs to summon food to the deceased.

3. This is a room devoted to earthly delights, such as pictographs of dancing, orgies, games and gatherings. Statues of the deceased and of various bestial gods and goddesses can also be found in this chamber. The incantations are meant to be read aloud by those entering the tombs to summon these delights to the deceased in the afterlife.

4. This chamber serves the same purpose as Area 13 in the previous mastaba example. Great sacrifices are made here at the time of the burial and whenever favours are desired of the deceased. Six great pillars designed like papyrus stalks fill the chamber. Great statues of funerary gods (and Set) line the walls, inset within the hieroglyphs and orgiastic-drawings on the walls. A black and bloody altar to Set is against the west wall here. Only the corrupt usually proceed further than this room.

hieroglyphs and orgiastic-drawings on the walls. A black and bloody altar to Set is against the west wall here. Only the corrupt usually proceed further than this room.

5. This chamber has the Book of the Dead carved on it. It also holds a whole procession of bestial and shambling gods with small altars for living sacrifices. The floors are usually blood-stained and black candles can be found inset within small niches in the walls, candles that, when lit, release a black light that make the hieroglyphs and pictures glow with an inhuman intensity. Just entering this room, unless one has at least one point of Corruption, is cause for a Terror check (DC 18). If the candles are lit, the Terror check is at a DC of 25. Ghosts and other horrible things often lurk in this chamber.

6. This is a serdâb set aside for the *ka* of the deceased. It is sometimes sealed completely. Sometimes a small shaft leads to the serdâb so incense can pass inside for the pleasure of the *ka*. It holds statues of the deceased and furnishings and it may contain a shaft to a burial chamber.

7. This chamber has statues of the deceased and his wife one either side of the passage leading from Chamber 5 as if they were walking from Chamber 5 into Chamber 7. Huge drawings

STYGIAN COMPLEX MASTABA

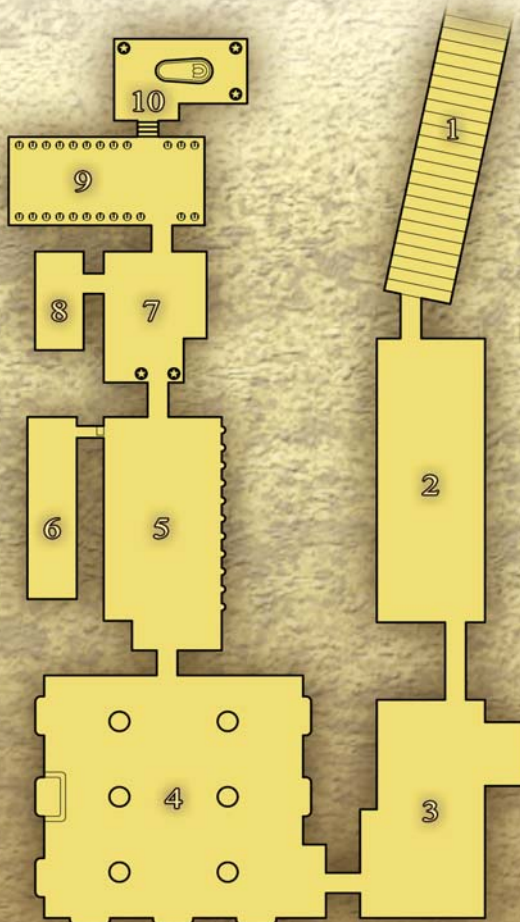

of the deceased, surrounded by smaller figures of his wife, children and attendants, are on the west wall, watching the statues enter the room. Along the north and south walls are depicted long lines of attendants bringing the deceased and his family the fruits and products of his estate. Scribes are shown as recording the gifts. Long lines of fattened animals are shown in beautiful relief, many shown in the act of being sacrificed or butchered. Naked men on papyrus boats are shown hauling in fish.

8. This room contains some belongings of the deceased.
9. This room is filled with ushabtiu figures of all sizes and the walls are painted to show servants performing their jobs for the deceased. The hieroglyphs on the walls are meant to be read aloud by those entering the tombs to order the servants in the paintings to serve the deceased in the afterlife.
10. This is the burial chamber of the owner of the mastaba and all of his earthly treasures. Statues of Yinepu stand guard over the sarcophagus of the deceased. It is sealed by two stone slabs. Sometimes the actual burial chamber is at the base of a deep shaft sunk in the centre of the chamber.

ROCK-CUT TOMBS

Often, constructing a new pyramid is too expensive for some kings and sorcerers and constructing a mastaba is too unsafe (thieves find them fairly easy to break into), so the Stygians also use rock-cut tombs. These tombs have simple exterior doors cut into cliffs and the tomb itself dives into the depths of the earth. Some tombs are far more complex than the one depicted here, having multiple halls branching off or other stairways going off in other directions, linking several of these tombs together.

1. The entry hall is a stairway going down. Along the wall are protective hieroglyphs, as well as the names and titles of everyone buried in the tomb, emphasising the primary tomb-owner if there is more than one person buried within. The passage narrows at the base of the stairs and either a stone slab (which had been lowered by ropes when the priests left the tomb) or a set of stone doors (sealed with a gold or bronze seal) bars the way. There is usually a door or slab at the entrance to the tomb which is the first symbolic door of the underworld and another door at the bottom of the stairs is considered the second symbolic door to the underworld.
2. This passage has a fairly steep downward slope but not steep enough that it cannot be negotiated without stairs. Some tombs have this stretch of hall level and not sloping at all. On each side of this hall are images of the deceased and smaller images of his wife, along with at least four rows of hieroglyphs giving the deceased's name and all of his titles. All

the images are in sunken relief. Designs showing the cycles of life fill out the rest of the entry hall. Some tombs have inset niches with statues of the deceased set within. The passage narrows at the base of the hall and either a stone slab (which had been lowered by ropes when the priests left the tomb) or a set of stone doors (sealed with a gold or bronze seal) bars the way. This is considered the third symbolic door to the underworld.

3. This is a steep stairway continuing the descent. Often the head of Set (or Yinepu) adorns the far wall, watching the stairs and those who ascend or descend. Chapter 87 of the Book of the Dead is written out on the left hand wall as one descends, giving the deceased the power to turn into a serpent so he can glide unharmed to the remotest parts of the world. Insets high in this wall have niches for the placement of mummified snakes. Chapter 88 of the Book of the Dead is written on the right hand wall as one descends, which spells out the formulae for turning the deceased into a crocodile so that he can strike terror into the hearts of all who see him and so that he can seize his prey when and where he wishes. Insets high in this wall have niches for the placement of small mummified crocodiles. The passage narrows at the base of the stairs and either a stone slab or a set of stone doors bars the way. This is considered the fourth symbolic door to the underworld.
4. This is another sloping passageway with at least four statues of ungainly bestial gods in the corners or in wall-niches. Some tombs have this chamber level instead of sloping. More chapters from the Book of the Dead are inscribed on the walls. Often Chapter 77 is inscribed, which teaches the deceased how to take the form of a golden hawk so he can fly to the sun and visit all of the sky at will. Chapter 72 is also inscribed, giving the deceased the secret name of Set so that he can be reborn in the afterlife in a place called the Mesqet. The inscription also teaches the deceased how to enter and leave his tomb at will. Chapter 70 is also inscribed (although sometimes other chapters are substituted if desired), which tells the deceased how to grab the east and north winds by their hair, the west wind by its beautiful body and the south wind by its eye and force them to take the deceased wherever the winds can blow, and so travel to all four corners of the after world. The sealed doors at the end of this chamber are symbolic of the fifth door to the after world.
5. This is the Hall of Waiting, which is essentially just a deep, dark pit. The priests use a wooden bridge to cross this and take the bridge with them when they leave the tomb to seal it. The door or slab on the other side of the pit is shut right on the rim of the pit so that thieves cannot bring ladders or bridges of their own to set over the pit; there is no ledge remaining to lay the wood upon. The stone slab is dropped via a rope and pulley system above the ceiling stones. This is the symbolic sixth door. It is almost always a stone slab and

ROCK CUT TOMB

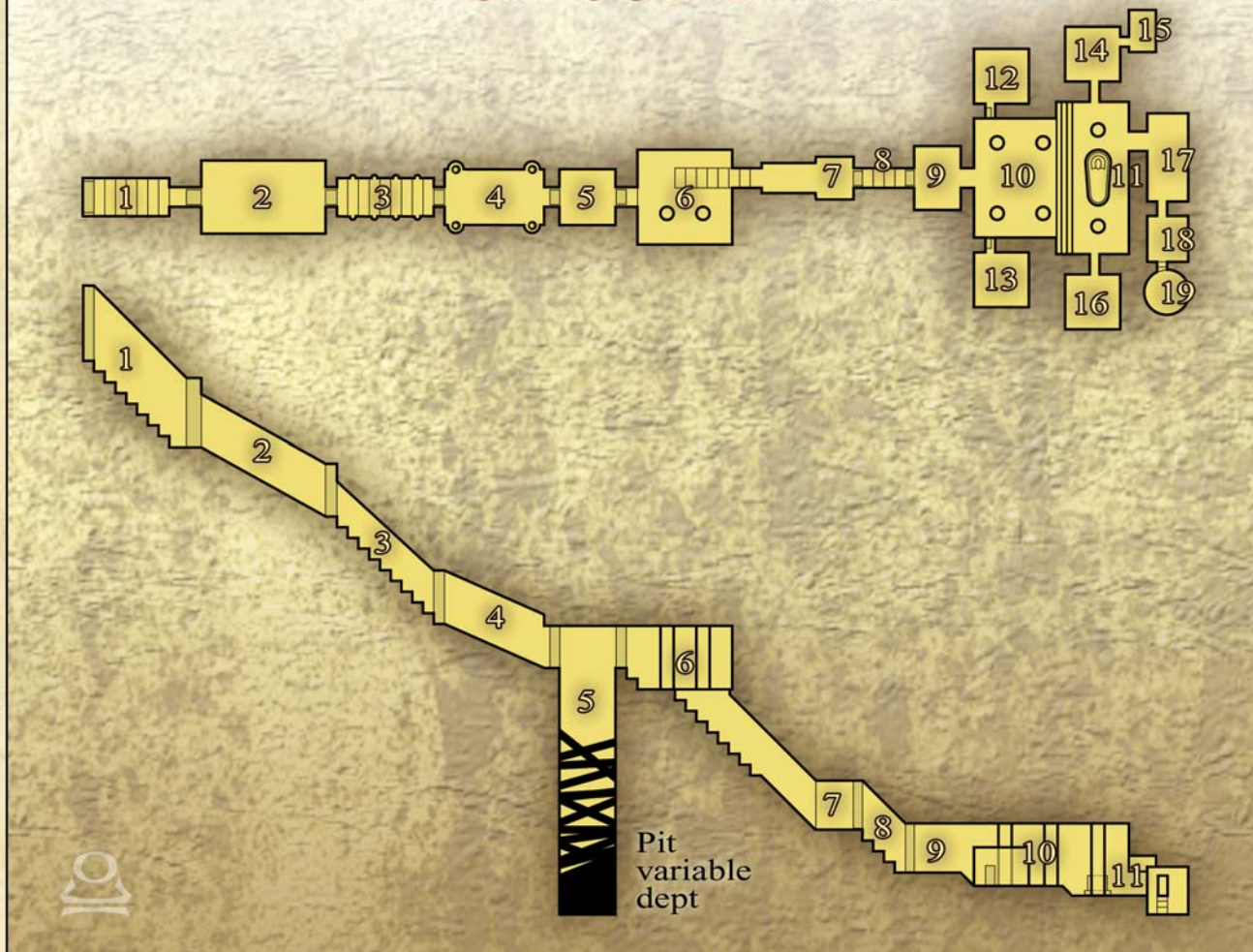

TOMB SAND PYRAMIDS

not a sealed door. The walls are inscribed with images of the gods of the after world. The tombs of sorcerers may include a demon at the bottom of the pit, such as a foaming blasphemy (see page 145). Most tombs, however, do not include the demon.

6. This level hall is inscribed with paintings of every-day life, especially showing servants doing labour while the deceased, in giant form, watches. This is the first chamber in the tomb that is not sloped. The floor is littered with hundreds of ushabtiu figurines doing labour or just standing. Dioramas, free-standing statues and tools can be found throughout this chamber. Two to six columns (depending on the size of the chamber) hold up the ceiling and depict gods, workmen and the deceased. Prayers entreating the ushabtiu to do work for the deceased are inscribed on the walls. A stairway leads further down into the dark tomb.
7. This sloping hall depicts the opening-of-the-mouth ceremony in elaborate detail, allowing the deceased to occupy his mummy or any of the statues in the tomb, among other powers and abilities granted. Should the

name of the deceased be defaced entirely from this room, the *ka* will be seriously crippled and impoverished, if not killed.

8. After passing through the seventh door, the traveller is met with another steep set of stairs. More passages from the Book of the Dead about the Opening of the Mouth ceremony decorate the darksome walls. At the base of the stairs stands the eighth door/slab.
9. The Hall of Truth, a room for prayer and reflection.
10. The House of Gold: This is where most of the treasure is stored. There are four to eight columns in the room and treasure is usually piled all over the floors, including furnishings for the deceased's *ka* to recline in.
11. Hall of the Dead, the burial chamber of the deceased. Within the burial chamber is a large, red granite sarcophagus. The walls are painted with the funerary texts and images of the gods. The chamber also has several statues of lumbering monster-gods, including a sinister figure of Set.

12. This is a serdâb set aside for the *ka* of the deceased. It holds statues of the deceased and furnishings. It may contain a shaft to a burial chamber.
13. This is a serdâb set aside for the *ka* of the deceased. It holds stored food offerings or emblems of food.
14. This is a burial chamber for a wife or child of the deceased. It may have a statue of a shambling and bestial god. It usually has a shaft down to a down to the sarcophagus chamber. The squared shaft is usually about two or three feet a side and anywhere from sixty to a hundred feet deep. Another stele at the base of the shaft seals the actual burial chamber, which has the sarcophagus and the mummy within. The room may be sealed off, have a small hallway leading to it or it may have a small window that leads to the serdâb. If the deceased has additional family to be buried with him, they may be placed in rooms off this one, such as room 15 in the sample map.
15. Another burial chamber for another wife and/or child, similar in all ways to chamber 14.
16. This is an annex used to store funerary equipment.
17. This chamber has the Book of the Dead carved on it. This chamber also holds a whole procession of bestial and shambling gods with small altars for living sacrifices. The floors are usually blood-stained and black candles can be found inset within small niches in the walls, candles that, when lit, release a black light that make the hieroglyphs and pictures glow with an inhuman intensity. Just entering this room, unless one has at least one point of Corruption, is cause for a Terror check (DC 18). If the candles are lit, the Terror check is at a DC of 25. Ghosts and other horrible things often lurk in this chamber.
18. This is an annex used to store funerary and shrine equipment.
19. This is a sacrificial chamber and/or pit.

HAUNTED PYRAMIDS

The black pyramids of Stygia are their most well known monuments, a source of eternal pride for the Stygians and a source for unending horror for everyone else. The pyramids are usually part of a pyramid complex. They are also tombs and temples. Giant-Kings, ancient priests and sorcerers and man-serpents might be found entombed within, not to mention ghouls, ghosts and vampires.

Pyramid Complex

Pyramids do not just stand alone in the desert unless they have been forgotten or abandoned. Even then there are surrounding ruins. Pyramids are the centre of an entire complex. Often the ruins of these complexes are little more than mounds of

No man could approach one of those sombre piles of black stone without apprehension. The very name was a symbol of repellent horror among the northern nations, and legends hinted that the Stygians did not build them: that they were in the land at whatever immeasurably ancient date the dark-skinned people came into the land of the great river.

Robert E. Howard, *The Hour of the Dragon*

rubble, although the pyramids still in use by the Cult of Set usually have managed to maintain the complexes.

1. **The Pyramid:** There are over 90 pyramids throughout the kingdom of Stygia. Some are little more than crumbling ruins, barely distinguishable from a rock formation or hill. Others are imposing structures of colossal proportions. Virtually all are made of black stone (although at least one is known to be made of red stone) and are frightening to behold because of the unnamed horrors known to lurk below each. The pyramids are the burial places of the Giant-Kings and the Elder Priests of Stygia. They are temples to Set and to the dead. The pyramids can be entered through great bronze doors flanked by sphinxes.
2. **Outer Enclosure Wall:** A great, black enclosure wall demarcates the sacred area of the whole complex. The walls are made of stone rubble. They may or may not be inscribed with hieroglyphs.
3. **Inner Enclosure Wall:** Another black enclosure made of stone rubble, this wall marks off the court. It may or may not be inscribed with hieroglyphs.
4. **Mortuary Temple:** Located on the east side of the pyramid, this is usually a simple temple devoted to those buried there. The oldest pyramids retain the simple plan. More recent ones have additional wings added to the north and south sides of the temples.
5. **Subsidiary Pyramids:** Most pyramid complexes have smaller pyramids for the burial of queens, wives or mothers. Sometimes they are simply temples. They are made of the same black stone as the rest of the complex.
6. **Boat Pits:** Located around the pyramid and the causeway, these pits contain buried boats. They number anywhere from none to twelve.
7. **Workshop:** Statues, stone, pottery vessels and anything else needed for maintenance of the pyramid cult are usually made within the complex. Bread and beer is also made here to feed the personnel of the necropolis and pyramid city.

PYRAMID TEMPLE COMPLEX



COMESANDOPYRAMIDS

8. **Causeway:** This is a sloping roadway connecting the valley temple to the mortuary temple. The causeways are decorated with bestial reliefs of grim gods. Statues (especially of sphinxes) may also decorate the causeway.
9. **Valley Temple:** This temple is built on the edge of the agricultural floodplain.
10. **Pyramid City:** Always located near the valley temple, this city houses the personnel who maintain the cult of the kings and sorcerers buried within the pyramid. The city is governed by a priestly overseer.
11. **Harbour:** In front of the valley temple is a harbour connected to a canal leading to the River Styx. When the pyramids and the complex were constructed, this harbour was where stone and other materials were unloaded. Now it is used to bring supplies to the pyramid city.
12. **Funerary Domain:** This is a farm on the fertile flood plain where the pyramid complex produces its own agricultural and animal products. Half of the produce takes care of the people in the pyramid city and the other half goes to either the king (if the pyramid complex is near Luxur) or to the governor of the nearest city.
13. **The Palace:** Historically, most of the pyramids of Stygia were built by the Giant-Kings before the arrival

of the Khari. During the construction of the pyramids, the Giant-King ruling Elder Stygia lived in a palace near the pyramid. Here the Giant-Kings ruled their kingdom and supervised the building of the pyramids. Thus, each Giant-King had a different capital for their individual reigns. The Stygians, on the other hand, keep their capital at Luxur. All current palaces near the black pyramids are in ruins.

14. **The Workmen's City:** During the construction of a pyramid, the labourers and artisans lived here. After the pyramid is completed, the city is abandoned.
15. **Shaft Tombs of Family Members:** Mastaba tombs, usually of the most basic design, are placed here for family members or special servants.

Pyramid Interiors

Some pyramids began as mastabas and had a pyramid built on top of them. They have internal passages just as either of the mastabas given earlier in this chapter. Other pyramids are built on top of rock-cut style tombs. The tomb given for the rock-cut sample tomb could also work just as well for a pyramid tomb.

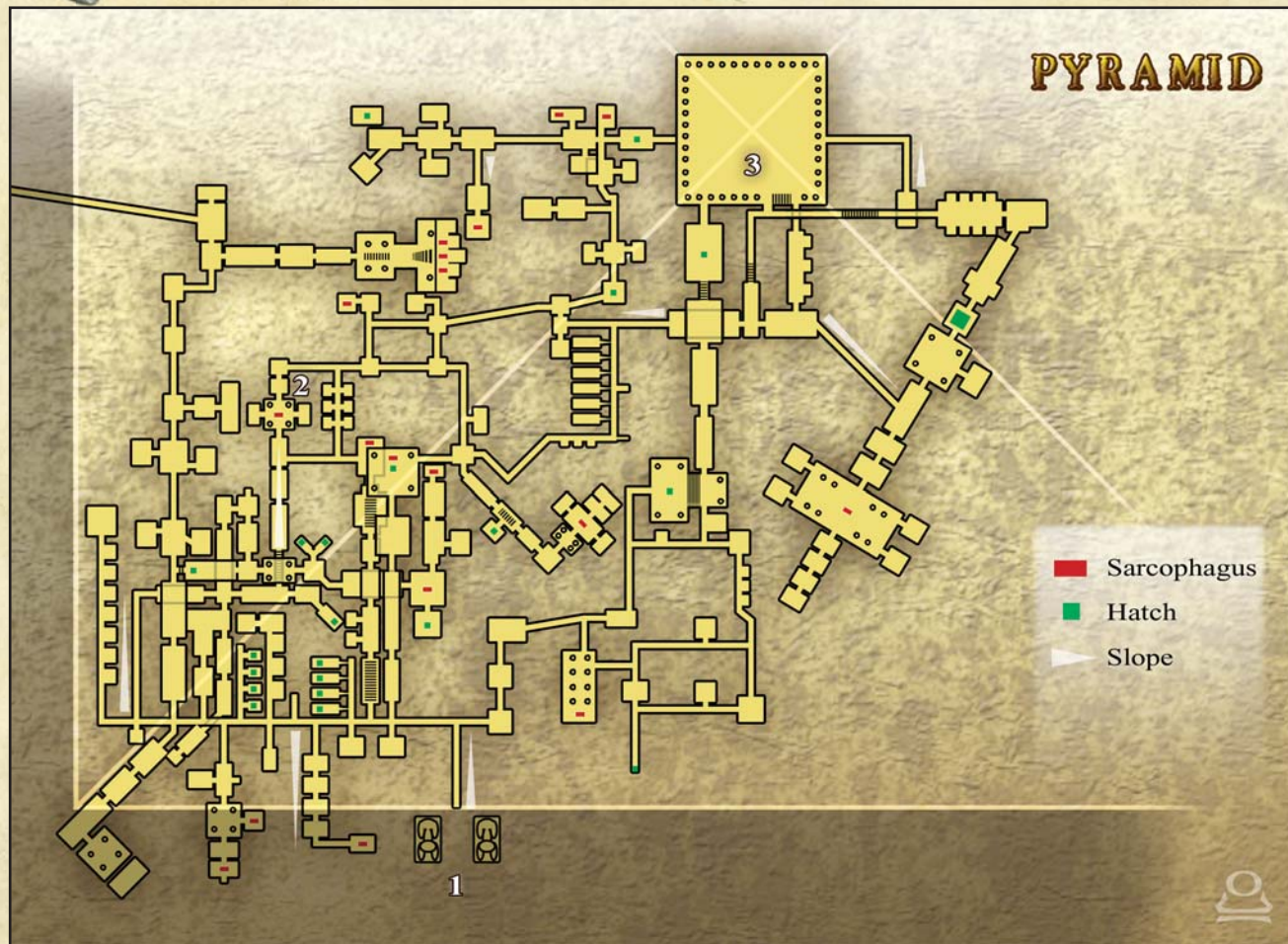

Some are even more complex, although making them overly complex has caused some of the ancient pyramids to weaken and crumble because too much of the supporting ground has been cut away. The sample here describes the interior of the Grand Pyramid outside of Khemi, which is the most complex pyramid currently explored in Stygia.

Many of the floors slope up or down and the tombs criss-cross above and beneath each other, like hundreds of rock-cut tombs all honey-combed and interlinked together. Most of the shafts lead to sarcophagus chambers, often holding bowl sarcophagi with sleeping gods sealed within. Demons, ghouls and vampires prowl the shafts and corridors of this pyramid. This map only shows the Priest's Entrance. Two other sides of the pyramid have an entrance; a King's Entrance and a Queen's Entrance. There are too many rooms, so only the areas described in *The Hour of the Dragon* will be delineated here.

1. The Entrance: The entrance to the pyramid is not through the mortuary temple, but through a set of copper doors on the side of the pyramid. On either side of the doors brood a pair of stone lions with the heads of women, described by

Howard as 'cryptic, inscrutable, nightmares crystallised in stone.'

2. **Akivasha's Tomb:** This chamber is lit by a curious seven-branched candelabrum in which black candles burn weirdly. The chamber is square, with walls and ceiling of polished black marble, furnished after the manner of the ancient Stygians; there is a couch of ebony, covered with black velvet, and on a black stone dais lays a carven mummy-case, engraved with the features of Akivasha. Various black arches open into the chamber. This is the home of Akivasha the vampire (*Conan: The Road of Kings* or *Conan: Stygia – Serpent of the South* for her statistics).
3. **Hall of the Dead:** Tier upon tier of carven, painted sarcophagi rise along the black walls high into the core of the pyramid above. Each sarcophagus stands in a niche within the dusky stone, and the tiers mount up and up to be lost in the gloom above. Thousands of carven masks stare impassively down at a black altar set within the chamber. The great sorcerer Thothmekri is one of the thousands entombed within this great chamber. It was in this chamber that Thutothmes tried to raise the dead with the *Heart of Ahriman* (See *Conan: The Scrolls of Skelos*) to learn all of its awesome powers.

Xuchotl

XUCHOTL IS THE ancient ruin encountered by Conan and Valeria in Robert E. Howard's final Conan story, *Red Nails*.

HISTORY

The city was built by Old Kosalans, an unknown race perhaps related to those who built the green stone cities. Driven out of their homeland by the modern Kosalans, the Old Kosalans wandered westward and found a forest-girdled plain where a tribe of black people lived. The Old Kosalans enslaved the village and built Xuchotl. Jade, marble, lapis lazuli, gold, silver and copper were brought in from the east. Herds of elephants were slaughtered for ivory. Once the city was completed, the Old Kosalans slew their black slaves. Having found ancient bones of dragons, the Old Kosalan necromancers brought the dragons back to life to guard the city.

For centuries the Old Kosalans lived in their city. At first they cultivated the fields outside but later their sorcerers learned how to grow food within the city, food nourished from the air instead of from the soil. As the centuries passed, they became slothful and decadent, degenerating and dying. Eventually their wizards all died and the people dwindled. No longer could they defend themselves, for they had no more warriors and no more sorcerers.

On Lake Zuad, the Tlazitlan culture had risen. Rebellious and fractious by nature, the Tlazitlan Stygians were apt to begin in new areas when the feuds became too intense. Mostly, they settled around Lake Zuad and those environs but they sent scouts all over, especially to the south. A bit more than 60 years before Conan and Valeria arrived, a group of soldiers (including a youth named Tolkemec) found Xuchotl. The soldiers were devoured by dragons and Tolkemec was enslaved by the Old Kosalans.

About 55 years before the arrival of Conan and Valeria, the Tlazitlans of Lake Zuad, led by the brothers Tecuhltli and Xotalanc, rebelled against the Stygian king and, with a thousand fighting-men and probably just as many women and children, left Stygia. They rebelled because the king of Stygia desired Tascela as a concubine. They encountered the dragons, who killed scores of the fighting-men, so they took refuge outside of Xuchotl. The Old Kosalans shut the doors and shot arrows at the Tlazitlans. That night, the

slave Tolkemec, recognising his own race, left the city and promised to let them in on the condition that any captives would be handed over to him. The Tlazitlans agreed to the terms and Tolkemec let the warriors into the city. Only a few hundred Old Kosalans were left and they were quickly put to the sword. A hundred captives were given to Tolkemec and he tortured each of them to death for the indignity of enslavement by them.

The two brother chieftains permitted Tolkemec an equal share of the power for his role in the conquest and because Tolkemec had learned so much of the sorcery of the Old Kosalans. For five years, the Tlazitlans dwelt in peace, ruled by Tecuhltli, Xotalanc and Tolkemec. Tolkemec showed the Tlazitlans how to cultivate the air-grown food so they would not have to work. They ate, drank and made love. They found they were trapped in the city, though, because of the dragons. The trio divided the city into three parts. Tecuhltli took the western end, Xotalanc the eastern and Tolkemec the southern.

Fifty years before the arrival of Conan and Valeria, Xotalanc took Tascela as a wife. She was already centuries old but beautiful and Xotalanc's brother, Tecuhltli desired her. Tolkemec, although now married, also desired her. Tascela, a black-hearted temptress, encouraged the feud between the trio. She finally chose her brother-in-law and went with him. Her husband tried to take her back and blood was spilled. Thus, a feud developed. Tolkemec and his people sided with one brother, then with the other, betraying both in repeated successions. The sections of the city were fortified and sealed off like great castles. Outraged at the betrayals and monstrous sorceries practised by Tolkemec and his people, Tecuhltli's people stormed the southern fortress and slew all of Tolkemec's people. Tolkemec was tortured and thrown into the catacombs to die.

Fifteen years prior to their extinction the last child of the Xuchotl Tlazitlans was born. A dozen years before the arrival of Conan and Valeria the great dragons slew themselves, save for one great monster – which was slain by Conan.

They dressed scantily in silks and jewels and they considered the monsters that roam the encircling jungles as immortal

dragon-gods. Those stegosaurian dragons were resurrected by dark necromancy and kept out of the plains area by magic cast by the original Kosalan builders. The Tlazitlans eventually exterminated themselves and the city was devoid of human life when Conan and Valeria left it.

LAYOUT

The city is not unlike many of the green stone cities discussed in prior chapters. Some researchers have concluded that Xuchotl is a green stone city because of its layout, despite not being made entirely of green stone.

EXTERIOR

Xuchotl is an ancient oval-shaped city located to the south, in the jungles that infest the lands of Darfar and beyond. The jungles have Apples of Derketo (see *Conan the Roleplaying Game*) growing profusely. The immediate terrain surrounding the city is a few miles of desert-like savannah complete with cacti. The plain is circular, surrounded entirely by jungle. The plain shows evidence of prior cultivation but this evidence is hundreds of years old. Partially filled-in irrigation canals and ancient furrows can be discerned with reasonable ease.

The city looks black in the night, and blood red in the day and is entirely enclosed by a great wall. The entire city is roofed in one manner or another, with tremendous halls used as streets, massive four storey houses and mansions and long spires extending high into the skies. The only way into the city is through the four city gates, each facing one of the cardinal directions.

INTERIOR

Inside, the city is green and crimson, for the very walls are made of jade and the floors are tiled in the curious red stone used for the exterior. The ceilings are comprised of lapis lazuli and strange green fire-stones are set in the ceilings that glow with a sickly, wan light. Some of the homes are walled in marble, ivory or chalcedony instead of the jade found in the halls. In some places skylights of clear crystal allow the sunlight in. There are no windows or exterior streets. Furniture of marble, jade or carnelian squat on Khitan silk rugs amid thick cobwebs. Friezes of bronze, gold and silver decorate the walls, displaying the original eastern builders feasting, dancing and lovemaking.

There are four tiers of chambers, halls and rooms in Xuchotl, with galleries and stairs. The lower three tiers are lit only by the strange green fire-stones. Any character who does not have Corruption 1+ will feel distinctly unnerved when in an area lit by one or more green fire-stones. If he lives in such an area for a week or

more, he must make a Corruption save (DC 15) or gain 1 point of Corruption. Characters who already have at least 1 point of Corruption are unaffected and may even rather enjoy the glow. Not all the chambers have lit fire-stones, however. Many are completely dark. In any given chamber or hall, there is only a 30% chance the room is lit. The uppermost tier is lit both with fire-stones and slot-like windows set on the steep-sloped roofs.

The artwork is distinct enough that anyone who has been to Kosala, known some Kosalans or makes a Knowledge (geography) check (DC 18) can recognise that the builders came from Kosala or thereabouts.

There are no streets, no squares nor open courts in Xuchotl. The whole city is built like one giant palace under a great roof of towers, spires and domes. The city is bisected from north to south by the Great Hall. The chambers and halls around the Great Hall (until the citadels of Tecuhltli, Xotalanc and Tolkemec are reached) are known as the Halls of Silence and served as a no-man's-land during the feud of the Tlazitlans, a brooding region of stark terror and grim battle.

Each chamber, stair and hall in the city was given a name by the Tlazitlans, although most of these names were lost to history when the last of the Xuchotl Tlazitlans died.

Tecuhltli

The western half has been sealed off save for four main bronze doors (and a few secret doors) and was the citadel of the Tecuhltli. Each of the main doors has an Eye, a system of mirrors which allow a person on the inside of the citadel to view someone standing outside the door. The bronze valves are locked by a series of heavy bolts and a chain. The four tiers of their citadel, from top to bottom, were named The Eagle's Tier, The Ape's Tier, the Tiger's Tier and the Serpent's Tier. The doors to those tiers bear the same name as the tier; the Door of the Eagle leads from the Halls of Silence to the Eagle's Tier, for example. A long, curving stair leads from the Tiers down to the catacombs. Spires and towers rise from the Eagle's Tier and have the only windows which allow a view of the surrounding plain. The windows are said to be unbreakable.

Catacombs

The crypts of the catacombs contain grisly secrets of ancient kings and wizards, especially those under the citadel of Xotalanc, where the most powerful wizards had been laid to rest. Out of the black night of the catacombs can be conjured weird creatures and mysterious magic items. It is toward these dark crypts of immemorial wizardry that many scholars are drawn.

XUCHOTL

GROUND FLOOR

Tecuhltli

Xotalanc

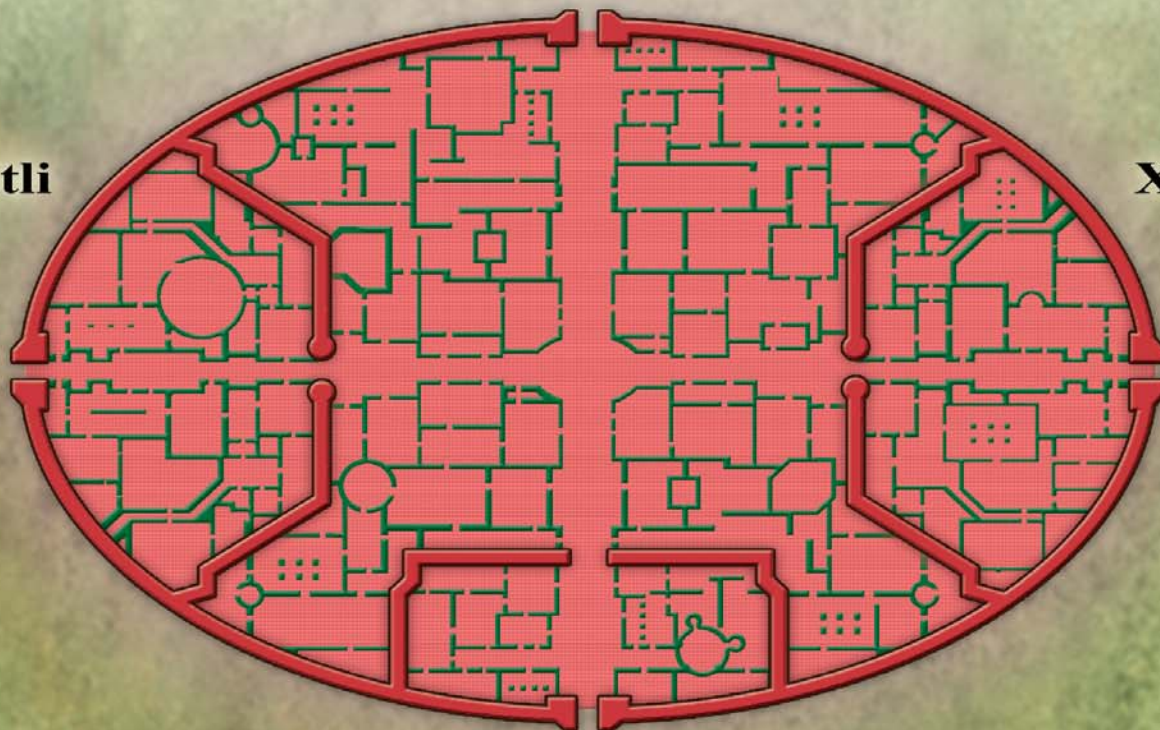

Tolchemec

SECOND FLOOR

Tecuhltli

Xotalanc

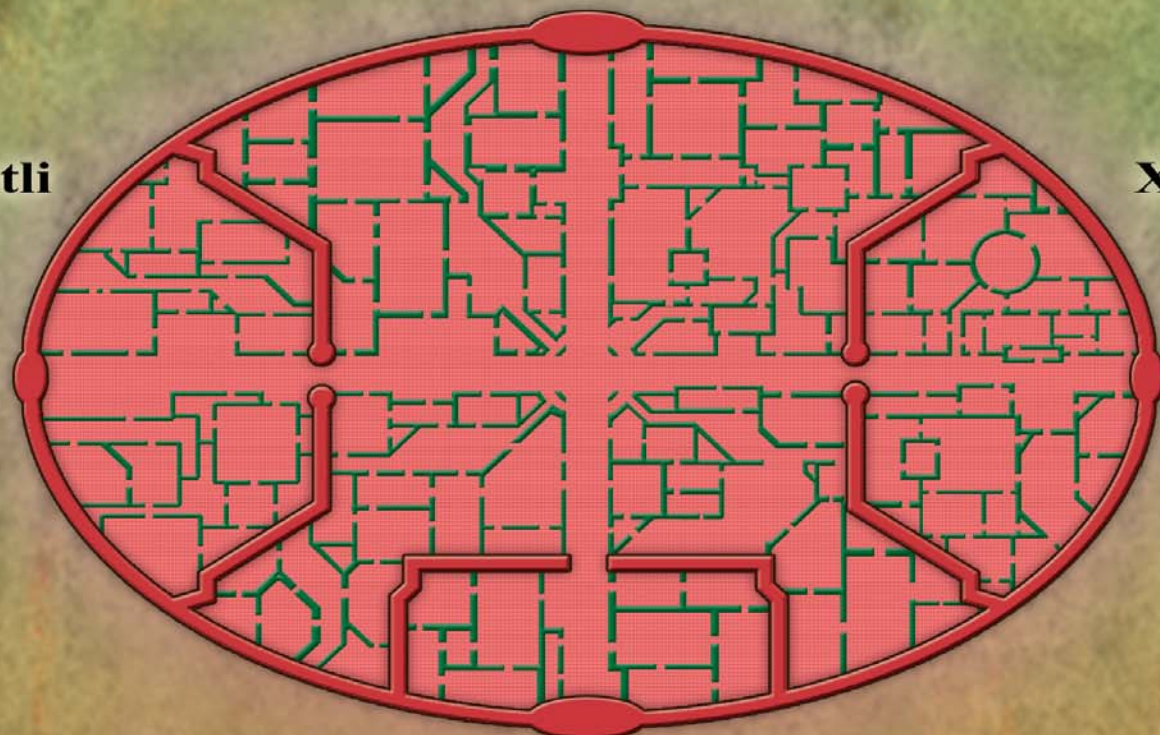

Tolchemec

XUCHOTL

THIRD FLOOR

Tecuhltli

Xotalanc

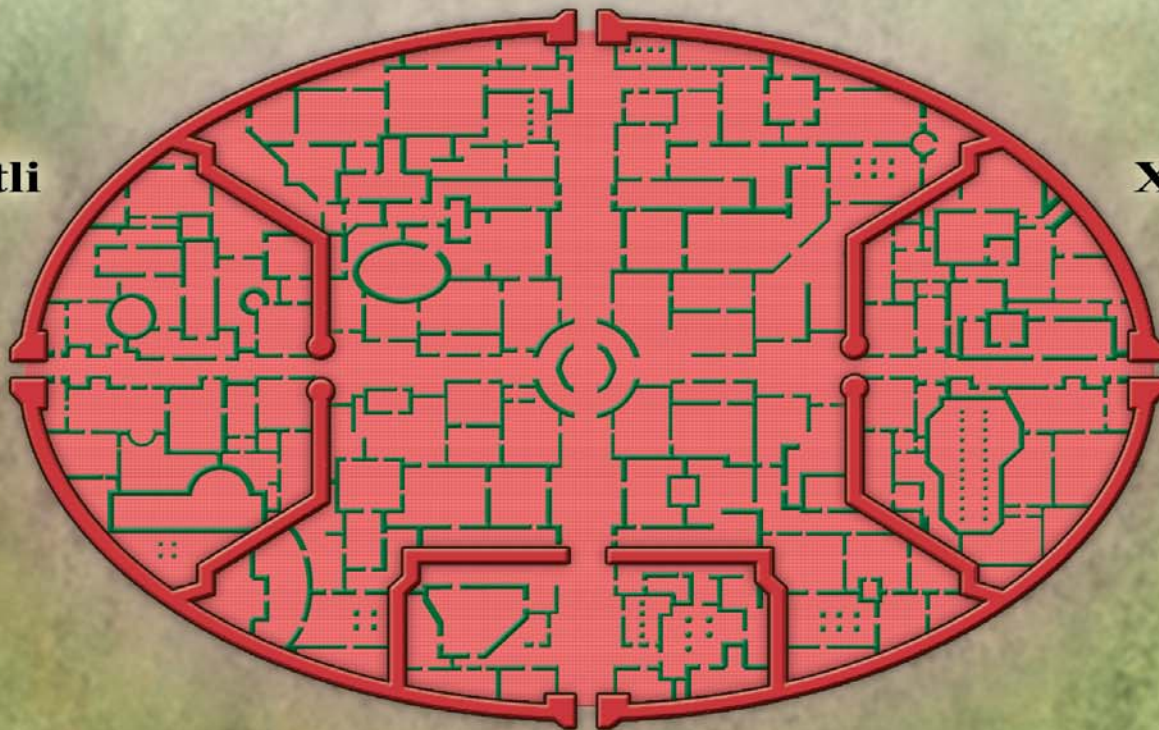

Tolchemec

TOP FLOOR

Tecuhltli

Xotalanc

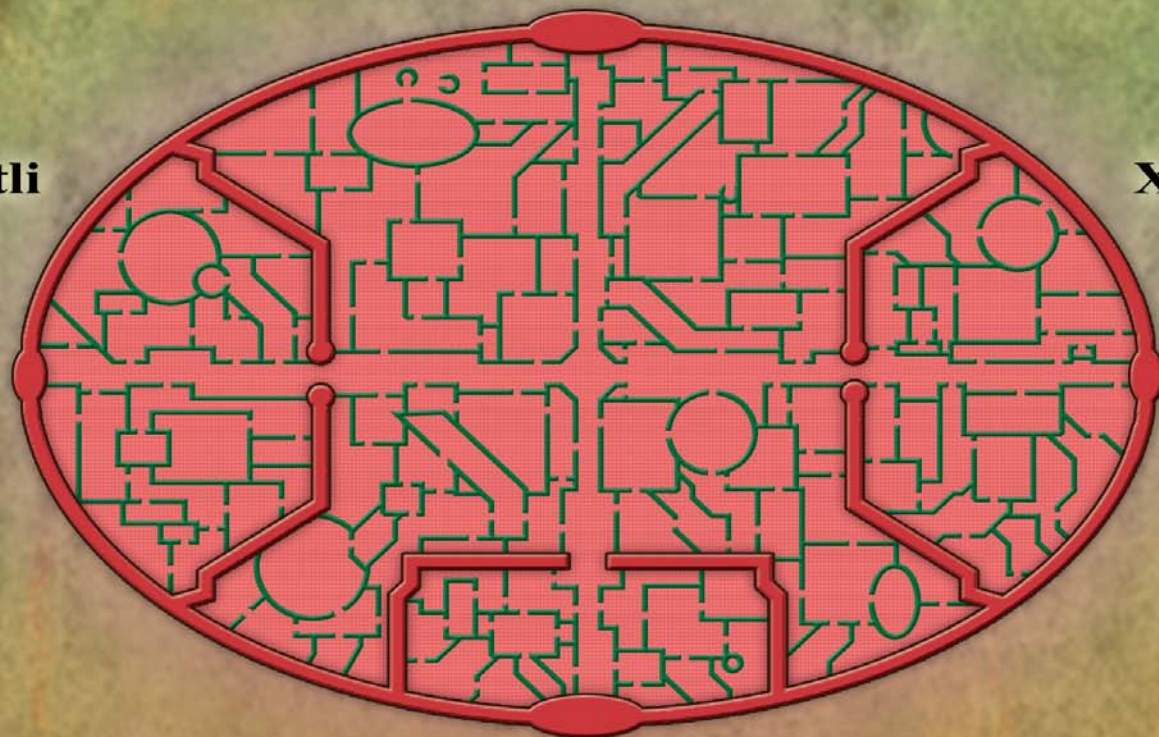

Tolchemec

MAGIC & UNUSUAL ITEMS KNOWN TO BE IN XUCHOTL

There are unknown secrets and monstrous things lurking in Xuchotl and its catacombs. The Games Master can easily place virtually anything here. There are few items known for sure to exist in Xuchotl as they were mentioned in the story *Red Nails*. Other than the Burning Skull (which was smashed by Valeria), the other items are still in the city at the story's end.

BURNING SKULL OF XUCHOTL

This dreadful artefact is one of the most feared remaining creations of the original inhabitants of Xuchotl, one of the weird green cities of the Southern Desert. Like many of the magicks of Xuchotl, it is not especially versatile, but within its specialty it is incredibly powerful. The *burning skull of Xuchotl* grants a +5 competence bonus to all Intimidate checks.

Furthermore, it automatically attempts to create a spell-like effect similar to a *mass hypnotic suggestion* all characters within a 90-degree arc and a 30 feet range each round. The arc may be selected by the wearer as a free action each round. Unlike a true *mass hypnotic suggestion*, the effect produced by the *burning skull* is based on contact with its eyes, rather than voice. The *mass hypnotic suggestion* will always be to simply stand stock-still in terror. Characters affected are unable to take any actions and are also helpless. They may attempt a Will save (DC 20) to resist the spell-like effect.

One was destroyed by Valeria. There may well be others.

Manufacturing Costs: 412,500 sp; 41,250 xp; caster level 20th.

GREEN FIRE-STONES

These large green stones are found in the jungles of Punt and elsewhere on the continent of Kush. A green fire-stone gives off a weird, unnerving glow, clearly illuminating a 10-foot radius area and casting flickering shadows over a wider area. A cluster of three fire-stones will illuminate a 20-foot radius.

Due to their weight (5 pounds each) green fire-stones are rarely used as portable illumination, but would be good for permanently lighting the interior of a building if they were not so odd. As it is, they are likely to be used only by sorcerers, scholars, and those of a similarly twisted demeanour. Anyone who does not have Corruption 1+ will feel distinctly

unnerved when in an area lit by one or more green fire-stones. If he lives in such an area for a week or more, he must make a Corruption save (DC 15) or gain 1 point of Corruption. Characters who already have at least 1 point of Corruption are unaffected and may even rather enjoy the glow. These are unusual items, not magic items.

Purchase Price: 150 sp. A character searching for green fire-stones in the appropriate place (warm jungles anywhere in the continent of Kush) may make a Search check once per week, with a +2 circumstance bonus if in Punt. A check result of 25 or higher means he has found a green fire-stone, with an additional fire-stone found for each additional 5 points he made the roll by.

PIPES OF MADNESS

All those who hear these pipes go screaming insane, acting more or less randomly. The pipes may be played as a full-round action by any scholar with 10 or more ranks of Perform (pipes).

This spell renders the targets unable to independently determine what they will do. All creatures within 60 feet of the piper must make Will saves (DC 19 for pipes made by an 18th level scholar) or be maddened by the terrible music. Creatures who are unable to hear, either permanently by virtue of their deaf or earless state, or temporarily by stopping up their ears by some means, are unaffected.

Roll on the following table at the beginning of each maddened subject's turn each round to see what the subject does in that round.

d%	Behaviour
01-10	Attack piper with melee or ranged weapons (or close with piper if attack is not possible).
11-20	Act normally.
21-50	Do nothing but stand staring into the distance, rendered speechless and immobile by cosmic anguish.
51-70	Flee away from piper at top possible speed.
71-100	Attack nearest creature.

A maddened character who cannot carry out the indicated action does nothing but stand staring into the distance, rendered speechless and immobile by cosmic anguish. Maddened characters have a -2 penalty to Defence Value, but otherwise attackers are not at any special advantage when attacking a maddened character. Any maddened character who is attacked automatically defends himself on his next turn. Note that a maddened character will not make attacks of opportunity against any creature that it is not already devoted to

attacking (either because of its most recent action or because it has just been attacked).

Maddened characters remain maddened for the duration of the piping and for 1d4 rounds thereafter. A character who successfully saves against the effects of *pipes of madness* cannot be affected by the pipes for 24 hours.

Manufacturing Costs: 100,000 sp; 10,000 xp; caster level 18th; spells required *entrance*, *mass hypnotic suggestion*.

PURPLE LOTUS WINE

The purple lotus mentioned in *Conan the Roleplaying Game* also grows around the shores of Lake Zuad, in southern Stygia, on the border with Kush. Certain Tlazitlan sorcerers brew a wine with its flowers, rather than extracting the juice to smear on their blades. This wine provides much the same effects as the juice, but acts as an ingested rather than injury poison. It also has the advantage that it looks and tastes much like any other good quality red wine (Craft (herbalism) check (DC 25) to realise it has been added to a liquid before drinking a full dose).

WAND OF CRIMSON FIRE

The *wand of crimson fire* is one of the secrets of the sorcerers of Xuchotl, the dread green city on the edge of the Southern Desert. A blast from its beam can lay low even a powerful warrior.

The wielder of the *wand* may blast out one beam from it for each attack he would usually be permitted to make. He may target anyone who is wearing a sizable quantity of metal (anything of 20 pounds or heavier, including armour and weaponry) or who is standing between the *wand* and a sizable quantity of metal, such as a metal pillar, doorway, altar or even another character in 20 pounds of metal armour. The target must make a Reflex save (DC set by the magic attack roll of the *wand's* wielder) or be struck by a beam of crimson fire that inflicts 5d6 fire and 2d6 electrical damage.

The *wand* may be used an unlimited number of times.

Manufacturing Costs: 100,000 sp; 10,000 xp; caster level 20th; spell required *summon elemental*; special requirement – the caster must summon up one fire elemental while creating the *wand* and bind it permanently into the *wand*, which will serve to earn him the lifelong enmity of all other fire elementals.

MONSTERS OF XUCHOTL

Red Nails features two memorable monsters in the region of Xuchotl. The Crawler is a monster summoned from the catacombs and the dragons live in the jungles around the city. Although the only known Crawler was killed by Conan, it is not inconceivable that there are more, and although the inhabitants claim Conan also killed the last dragon, this is also unproven.

CRAWLER OF XUCHOTL

Huge Magical Beast (cold)

Hit Dice: 14d10 (77 hp)

Initiative: +15 (+3 Dex, +12 Reflex)

Speed: 30 ft. (6 squares), climb 30 ft.

Dodge Defence: 21 (–2 size, +3 Dex, +10 natural)

DR: 4

Base Attack/Grapple: +14/+28

Attack: Slam +19 melee (1d8+6 plus 2d6 cold)

Full Attack: Slam +19 melee (1d8+6 plus 2d6 cold) and bite +17 melee (1d10+3 plus 1d6 cold)

Space/Reach: 15 ft. (3)/10 ft. (2)

Special Attacks: Cold damage, constrict 1d8+9 plus 4d6 cold (AP 8), improved grab, trip.

Special Qualities: Cold subtype, darkvision (60 ft.), low-light vision

Saves: Fort +9, Ref +12, Will +5

Abilities: Str 23, Dex 17, Con 11, Int 2, Wis 12, Cha 2

Skills: Hide +1, Listen +10, Move Silently +8, Spot +6

Feats: Alertness, Multiattack, Stealthy, Weapon Focus (slam), Weapon Focus (bite)

Environment: Underground

Organisation: Solitary

Advancement: 15–20 HD (Huge); 21–32 HD (Gargantuan)

The crawler of Xuchotl resembles a large snake, but with a distinctly otherworldly look to its appearance. Its hue is indeterminate, usually dark but with an oddly shifting quality that makes it look alternately black, dark grey, brownish-purple and dark brown. In fact it is a native of Earth, but a twisted, sorcerous one, a creature that crawled up from the deepest caverns and tunnels below the surface and up to the catacombs beneath the lost city of Xuchotl. Certain sorcerers and factions of Xuchotl have been known to tame or control it.



...Conan released her and turned on the steps, his ears and instincts telling him their foes were hard at their backs. And the sounds were not all those of human feet.

Something came writhing up the steps, something that slithered and rustled and brought a chill in the air with it. Conan lashed down with his great sword and felt the blade shear through something that might have been flesh and bone, and cut deep into the stair beneath. Something touched his foot that chilled like the touch of frost, and then the darkness beneath him was disturbed by a frightful thrashing and lashing, and a man cried out in agony.

Robert E. Howard, *Red Nails*

A crawler might be encountered in Xuchotl or one of the other similar green-jade lost cities such as Xuthal or the structure on the *Isle of the Black Ones*. Alternatively, characters venturing far enough below the surface may come upon a crawler in its natural habitat.

COMBAT

Crawlers of Xuchotl use a slam attack to knock their opponents down before moving in to bite and constrict, trusting to their icy touch to rapidly finish off most enemies.

Cold Damage (Su): Every hit by a crawler of Xuchotl also deals cold damage in various quantities. A character struck by a crawler may attempt a Fortitude saving throw (DC 17) for half damage from the cold. A character with the Endurance feat may apply his +4 bonus from the feat to this saving throw.

Cold Subtype (Ex): Cold immunity; double damage from fire except on a successful save.

Constrict (Ex): On a successful grapple check, a crawler of Xuchotl deals 1d8+9 damage, and an additional +4d6 cold damage.

Improved Grab (Ex): To use this ability, a crawler of Xuchotl must hit with its bite attack. It can then attempt to start a grapple as a free action without provoking an attack of opportunity. If it wins the grapple check, it establishes a hold and can constrict.

Trip (Ex): A crawler of Xuchotl that hits with a slam attack can attempt to trip the opponent as a free action without making a touch attack or provoking an attack of opportunity. If the attempt fails, the opponent cannot react to trip the crawler.

Skills: A crawler of Xuchotl's keen hearing grants it a +4 racial bonus to all Listen checks.

XUCHOTL



DRAGON

Huge Animal

Hit Dice: 16d8+112 (184 hp)

Initiative: +6 (–2 Dex, +8 Reflex)

Speed: 40 ft. (8 squares)

Dodge Defence: 18 (–2 size, –2 Dex, +12 natural)

Damage Reduction: 9

Base Attack/Grapple: +12/+32

Attack: Gore +22 melee (3d6+12)

Full Attack: Gore +22 melee (3d6+12) and 2 slams +17
melee (2d8+6) and sting +17 melee (2d6+6 plus poison)

Space/Reach: 15 ft. (3)/10 ft. (2)

Special Attacks: Powerful charge, trample 2d8+18, poison

Special Qualities: Low-light vision, scent

Saves: Fort +17, Ref +8, Will +6

Abilities: Str 35, Dex 7, Con 25, Int 1, Wis 12, Cha 7

Skills: Listen +13, Spot +12

Feats: Alertness, Awesome Blow, Endurance, Improved Bull
Rush, Power Attack, Titanic Blow

Environment: Warm and temperate jungle and plains

Organisation: Solitary, pair or herd (3-18)

Advancement: 17–32 HD (Huge); 33–48 HD
(Gargantuan)

Dragons are enormous reptiles, covered in tough rusty-red scales and adorned with spikes. A dragon's huge jaws are surmounted by great tusks which can be used both in its great goring charge, and to clamp together and pull its victims into its gaping maw. A dragon has a body around 30 feet long and weighs about 30,000 pounds.

Dragons are legendary to the people of Kush, who recall tales their ancestors told of these great beasts that once roamed the land in an elder age. They were extinct, but were returned to life by the sorcerers of old Xuchotl to act as guardians around their city. Conan is believed to have slain the very last one during the events in *Red Nails*, though it is likely that the secrets of their resurrection can be found in ghost-haunted Xuchotl, and in any case a sufficiently powerful sorcerer could undoubtedly research the spells once more (see the *bones of life* spell from *Conan: The Scrolls of Skelos*).

Dragons eat fresh meat of any kind, and have voracious appetites. They never seem satisfied and will gorge themselves for as long as food is available. Horses and humans are particularly favoured as delectable dishes.

Combat

Dragons have a simple combat method: they prefer to charge into battle and swallow their enemies whole.

A foe who is too large to be eaten in one great gulp will be attacked furiously until it is in bite-sized pieces. Facing a

Through the thicket was thrust a head of nightmare and lunacy. Grinning jaws bared rows of dripping yellow tusks above the yawning mouth wrinkled a saurian-like snout. Huge eyes, like those of a python a thousand times magnified, stared unwinkingly at the petrified humans clinging to the rock above it. Blood smeared the scaly, flabby lips and dripped from the huge mouth.

The head, bigger than that of a crocodile, was further extended on a long scaled neck on which stood up rows of serrated spikes, and after it, crushing down the briars and saplings, waddled the body of a titan, a gigantic, barrel-bellied torso on absurdly short legs. The whitish belly almost raked the ground, while the serrated back-bone rose higher than Conan could have reached on tiptoe. A long spiked tail, like that of a gargantuan scorpion, trailed out behind.

Robert E. Howard, *Red Nails*

large number of small foes, the dragon will trample over them and devour the remains.

Improved Grab (Ex): To use this ability, a dragon must hit an opponent of up to one size smaller with its gore attack. It can then attempt to start a grapple as a free action without provoking an attack of opportunity. If it wins the grapple check, it establishes a hold and can try to swallow the foe the following round.

Poison (Ex): The dragon's stinging tail injects an injury poison. The save DC is 25, dealing initial and secondary damage 1d6 Str. The save DC is Constitution-based.

Powerful Charge (Ex): When a dragon charges, its gore attack deals 6d8+24 points of damage.

Trample (Ex): As a full-round action, a dragon may move up to twice its speed and literally run over any opponents at least one size category smaller than itself. The dragon merely has to move over the opponents in its path; any creature whose space is completely covered by the trampling creature's space is subject to the trample attack. If a target's space is larger than 5 feet, it is only considered trampled if the trampling creature moves over all the squares it occupies. If the trampling creature moves over only some of a target's space, the target can make an attack of opportunity against the trampling creature at a –4 penalty. A trampling creature that accidentally ends its movement in an illegal space returns to the last legal position it occupied, or the closest legal position, if there is a legal position that is closer. A trample attack deals bludgeoning damage (2d8+18). Trampled

opponents can attempt attacks of opportunity, but these take a -4 penalty. If they do not make attacks of opportunity, trampled opponents can attempt Reflex saves to take half damage (DC 30; Strength-based save DC). A trampling dragon may only deal trampling damage to each target once per round, no matter how many times its movement takes it over a target creature.

NEW RACE

Although the Xuchotl Tlazitlans were wiped out at the end of *Red Nails*, there were at least two expeditions to the city from Lake Zuad. The first brought Tolkemec to the city. The second brought Tecuhltli and Xotalanc to the city. It would not be inconceivable for a third bunch to arrive, although it is doubtful (or at least unbelievably coincidental) they would have the same sort of weird feud going on as the Tlazitlans encountered in *Red Nails*.

TLAZITLAN

The Tlazitlan folk are partly Stygian in origin, but some of their ancestors were of one or other of the Eastern races, perhaps Hyrkanians or Kosalans. Most Tlazitlans live around Lake Zuad, but a party of them settled in the far southern city of Xuchotl some 50 years ago. The Xuchotl Tlazitlans were destroyed during Conan's visit to Xuchotl described in the story *Red Nails*.

Culture: Tlazitlans are a good deal more wild and dangerous than the relatively civilised Stygians. Perhaps their most feared trait is their willingness to declare a feud against an enemy, dedicating both their own lives and those of their descendants to utterly destroying their foe.

Names: Tlazitlan names resemble Aztec, Mayan or Incan names. Examples: (male) Chicmec, Escelan, Olmec, Tachic, Techotl, Tolkamec, Topal, Xatmec, Zlanath; (female) Tascela, Yasala. Suggestions: (male) Maxtla, Tizoc; (female) Cihuaton, Izel, Tepin, Tlaco, Xoco.

Religion: Several strange ritualistic practices and superstitions are revealed by the people of Xuchotl. They mark the deaths of their enemies with symbolic red nails hammered into a totem pole, or with collections of heads preserved on glass-cased daises. They fear 'The Stalker in the Dark' and keep their dead in catacombs. It is difficult to be certain if these practices exist beyond Xuchotl, among the ordinary Tlazitlans. They swear by Set, showing their Stygian origins.

Tlazitlans use the following racial traits instead of the standard Stygian traits.

- ☼# +1 circumstance bonus to all Hide, Listen, Move Silently, Survival and Spot checks in any plains environment; +2 circumstance bonus to Survival checks made to get

along in the wild when a body of water is nearby and fishing equipment available. Tlazitlans herd cattle over the grasslands around Lake Zuad as well as fishing in it.

- ☼# +2 racial bonus to all Intimidate and Profession (torturer) checks. The Tlazitlans delight in inflicting pain, and are quite willing to threaten and carry out the direst tortures to get what they want.
- ☼# Feud. This is a special racial ability shared by all Tlazitlans. A Tlazitlan can declare a feud against one enemy or closely connected group of enemies at a time. The target could be anything from 'the merchant who cheated me last week' to 'the entire nation of Zamora'. His feud lasts until all his declared enemies are destroyed, after which another feud can be declared at least one month later if desired. He gains a +2 circumstance bonus to attack and damage rolls when fighting his declared enemies in melee combat, but has a -2 circumstance penalty to his Defence Value against their attacks due to his frenzied combat style.
- ☼# -1 racial penalty to all saving throws against Corruption, and -1 racial penalty to all saving throws against Terror. Tlazitlans are not quite so corrupt as most Stygians, but conversely they are less at home with sorcery and strange beasts.

Background Skills: Intimidate, Move Silently and Profession (torturer).

Favoured Class: Barbarian

Prohibited Classes: None

NON-PLAYER CHARACTERS FROM RED NAILS

The Non-Player Characters used in this sourcebook are not given Fate Points or languages. There are several reasons for this omission. First, if Non-Player Characters' use Fate Points as much as Player Characters, no one would ever get killed and the Player Characters' jobs will be that much harder. Fate Points exist primarily as an opportunity for players to influence the game in a favourable direction. Games Masters do not need that particular contrivance. Second, who knows what a Non-Player character has been through in his life? In both cases, the Games Master's discretion is required. If the Games Master wants to give the Non-Player Characters described throughout this book Fate Points, he is at leave to do so. Languages function in a similar manner. If the Games Master wants a character to speak a given language or not, then the character speaks or does not speak the given language.

Xuchotl is the ancient ruin encountered by Conan and Valeria in Howard's final Conan story, *Red Nails*. Note that many of the spells used by Tascela come from the *Conan: The Scrolls of Skelos* sourcebook. Also presented is a corrected version of Valeria.

CONAN THE FREE COMPANION

Male Cimmerian Barbarian 14/Thief 1/Soldier 1/Pirate 2

Medium Humanoid

Hit Dice: 8d10+40 plus 2d8+10 plus 18 plus 3 plus 2 (126 hit points)

Initiative: +26 (+6 Dex, +20 Ref)

Speed: 30 ft. (6 squares)

Dodge Defence: 27 (+11 level, +6 Dex)

Parry Defence: 24 (+6 level, +8 Str)

DR: 2

Base Attack /Grapple: +16/+24

Attack: Broadsword +24 melee (1d10+8, 19-20, x2, AP 11)

Full Attack: Broadsword +24/+19/+14/+9 melee (1d10+8, 19-20, x2, AP 11)

Special Attacks: Ferocious attack, greater crimson mist, sneak attack +1d6/+1d8, sneak attack style (broadsword), to sail a road of blood and slaughter, versatility (no penalty, double threat range)

Special Qualities: Bite sword, Cimmerian traits, fearless, improved mobility, improved uncanny dodge, pirate code (Barachan rockets and smoke), seamanship +1, trap disarming, trap sense +4

Magic Attack Bonus: +8 (+3 level, +5 Cha)

Power Points: 6 (base 2, +4 Wis)

Space/Reach: 5 ft. (1)/5 ft. (1)

Saves: Fort +19, Ref +20, Will +8 (+11 vs. Corruption)

Abilities: Str 26, Dex 22, Con 21, Int 20, Wis 19, Cha 20

Skills: Balance +12, Bluff +16, Climb +20, Craft (blacksmith) +7, Decipher Script +8, Gather Information +7, Hide +13, Intimidate +14, Jump +18, Knowledge (arcana) +11, Knowledge (geography) +15, Listen +16, Move Silently +20, Perform (song) +7, Profession (sailor) +12, Ride +11, Search +8, Spot +18, Survival +14, Swim +13, Tumble +10

Feats: Brawl, Combat Expertise, Dabbler (counterspells), Diehard, Endurance, Fighting-Madness, Improved Sunder, Leadership, Mobility, Mounted Combat, Navigation, Power Attack, Sleep Mastery, Striking Cobra, Track

Code of Honour: Barbaric

Reputation: 24 (Brave)

Leadership: 23/22 (11th level cohort; 250 1st level, 10 2nd level, 4 3rd level, 2 4th level, 1 5th level) (Note: Cohort and followers dead)

Allegiances: None

Possessions: Aquilonian broadsword, poniard, broad leather belt, short wide-legged silk breeches, flaring-topped boots, low-necked, wide-collared, wide-sleeved silk shirt

Conan the Cimmerian is described by Howard as a tall man with mighty shoulders and a deep chest, with a massive corded neck and heavily muscled limbs. He is dressed in short wide-legged silk breeches, flaring-topped boots, low-necked, wide-collared, wide-sleeved silk shirt and a broad leather belt with a broadsword and poniard. His brow is low and broad, his eyes a volcanic blue that smoulder as if with some inner fire. His dark, scarred, almost sinister face is that of a fighting-man, and his velvet garments cannot conceal the hard, dangerous lines of his limbs.

Conan is loud and vibrant, despising the ordinary and the dull. The key to his personality is *intensity*. Even when he appears impassive, turbulent passions are roiling invisibly behind the scenes. He never forgets a kindness and repays it handsomely. He never forgives injuries, either, and can wait years for vengeance. The word 'vengeance' is vital here as Conan of Cimmeria does not try to get 'even' – he conquers and destroys utterly those who betray or hurt him. When he sees a weakness in an opponent he moves in quickly for the kill. Even in his most mirthful moods there is always a hint of an imminent change of heart, a sense that there is, beneath the surface, a lurking and unpredictable violence that can erupt at any time. However, this intense and explosive nature serves Conan well. He is incredibly adaptable, able to channel his unconquerable, intense energies into new paths as needed, without looking back. He embarks regularly on entirely different roads in life almost instantly, thus is explained his wide range of character classes, moving from barbarian to thief to pirate to soldier and, ultimately, to noble. As Conan himself once said, in *The People of the Black Circle*, 'I was born in the Cimmerian hills where the people are all barbarians. I have been a mercenary soldier, a corsair, a *kozak*, and a hundred other things. What king has roamed the countries, fought the battles, loved the women, and won the plunder that I have?'

On a religious level, Conan believes in Crom, although he does not pray to that grim god. He also swears by other Cimmerian, Æsir, Zamorian and Shemite gods, although he does not pray or sacrifice to them either. Crom and his race of gods despise weaklings who call on them for aid and would likely make the situation worse for the petitioner. Cimmerians value individuality and self-worth; their gods expect them to take care of life themselves. Indeed, Crom only takes pride in a Cimmerian if that Cimmerian never calls upon him for aid in his life. Cimmerians are supposed to take what they want from life, not ask a god for blessings, wealth, health or anything else. Conan does not want to attract Crom's attention, or any god's and said, 'What use

to call on him? Little he cares if men live or die. Better to be silent than to call his attention to you; he will send you dooms, not fortune! He is grim and loveless...'

Conan's History: Conan was born on a battlefield, according to Robert E. Howard in a letter to P.S. Miller, during a fight between his Cimmerian tribe and a horde of raiding Vanir. The country claimed by and roved over by his clan lay in the northwest of Cimmeria, but Conan was of mixed blood, although a pure-bred Cimmerian. His grandfather was of a southern tribe who had fled from his own people due to a blood feud. The tales of his grandfather, who had taken part in many raids of the southern Hyborian kingdoms, roused Conan's interest in travelling. His father was a blacksmith (hence Conan's ranks in Craft (blacksmith)). At Venarium, Conan was about 15 years old and was already a formidable barbarian warrior, growing in reputation. He soon encountered *The Frost Giant's Daughter* when he fought with the Æsir against the Vanir. Captured by Hyperboreans, he escaped and made his way into Nemedias and encountered *The God in the Bowl*.

In Arenjun, a 2nd level barbarian/1st level thief, he learned something of thievery and encountered *The Tower of the Elephant*. Still in Zamora, he investigated *The Hall of the Dead* and then travelled to the west of Zamora where he had the adventure related by Howard as *Rogues in the House*. Conan then joined the Free Companions, serving as mercenaries for a rebel prince of eastern Koth. When the prince made peace, the Free Companions plundered Koth, Zamora and Turan impartially. Hunted down as *kozaki*, the Free Companions were slaughtered at the Ilbars River by Shah Amurath and his Turanians from Akif; Conan survived the massacre and avenged the deaths of his comrades-at-arms by killing Shah Amurath. After *Shadows in the Moonlight*, Conan joins the Red Brotherhood of the Vilayet. He is now a barbarian 5/ thief 1/soldier 1/pirate 1.

He becomes a mercenary, earning the name Conan the Throat-Slitter, and ends up in Khoraja in time to battle Natohk's horde in *Black Colossus*. His stint as a mercenary adds soldier levels to his total. Conan travelled to Argos and joined with Bêlit, *The Queen of the Black Coast*. He sailed with her for nearly three years and ended up on foot in the Black Kingdoms. He continues as mercenary, making his way to Khauran for the events told in *A Witch Shall Be Born*. He is now a barbarian 9/thief 1/soldier 1/pirate 1.

After Yezdigerd is crowned king of Turan, replacing his father, Yildiz, Conan finds himself in Zamboula. After *Shadows in Zamboula*, Conan heads toward Ophir. Conan is next seen as part of a rebel uprising in Koth, travelling through Shem and Stygia to Kush and beyond. He encounters *Xuthal of the Dusk* before returning as a *kozak* for *The Devil in Iron*. He is



next seen as a *hetman* among the Himelian tribesmen in *The People of the Black Circle*. He rescues the Devi of Vendhya from the Black Circle. Later, Argos and Koth attacked Stygia, then Koth switched sides. He is a barbarian 11/thief 1/soldier 1/pirate 1. Conan fought in a mercenary army for Argos and ended up, again, in the Black Kingdoms for *Drums of Tombalku*. In the black kingdoms he learned to dabble in the occult and learned the sign of Jhebbal Sag. He raised a small kingdom of black tribesmen just before *The Vale of Lost Women*, lost his kingdom and made his way to Kush in *The Snout in the Dark*.

After Numedides replaced King Vilerus as King of Aquilonia, Conan was in Pictland for the events of *Beyond the Black River* and *The Black Stranger*. Conan then embarks on career as a Barathan Pirate, taking a second level in the pirate class. He is now a Cimmerian barbarian 12/thief 1/soldier

XUTHAL

1/pirate 2. In *The Pool of the Black One*, Conan is forced to leave Tortage on a sinking boat. Conan continued his pirate activities but when his ships were sunk by the Zingarans, he became a mercenary. He travelled to Sukhmet on the Darfar border as a Free Companion, leaving them for the adventure narrated in *Red Nails*, wherein Conan travels from Stygia back into the Black Kingdoms.

MASTER OF THE CRAWLER

Male Tlazitlan Scholar 3/ Barbarian 4
Medium Humanoid (Tlazitlan)
Hit Dice: 3d6+3 plus 4d10+4 (39 hit points)
Initiative: +9 (+2 Dex, +7 Reflex)
Speed: 30 ft. (6 squares)
Dodge Defence: 17 (+2 Dex, +4 level, +1 dodge)
Parry Defence: 15 (+3 Str, +2 level)
Base Attack /Grapple: +6/+9
Attack: Wide-bladed sword +9 melee (1d10+3, 19-20, x2, AP 6)
Full Attack: Wide-bladed sword +9/+4 melee (1d10+3, 19-20, x2, AP 6)
Space/Reach: 5 ft. (1)/5 ft. (1)
Special Attacks: Crimson mist, sorcery, versatility (–2 penalty)
Special Qualities: +1 power point, advanced spell, base power points, bonus spell, bite sword, fearless, feud, independent background, knowledge is power, new sorcery style x2, scholar, Tlazitlan traits, trap sense +1
Saves: Fort +6, Ref +7, Will +4 (+3 vs. Corruption; +3 vs. Terror)
Abilities: Str 17, Dex 14, Con 13, Int 12, Wis 11, Cha 15
Skills: Handle Animal +12, Hide +10, Intimidate +12, Knowledge (arcana) +7, Knowledge (nature) +11, Knowledge (local) +7, Listen +6, Move Silently +10, Perform (pipes) +12, Perform (ritual) +8, Profession (torturer) +4, Spot +6
Feats: Alertness, Dodge, Endurance, Ritual Sacrifice, Stealthy, Track
Code of Honour: None
Reputation: 11 (cruel)
Leadership: –
Allegiances: Xotalanc
Base Power Points: 5 (4 base, +0 Wis, +1 bonus; 10 maximum)
Magical Attack: +4 (+2 level, +2 Cha)
Sorcery Styles: Counterspells, Nature Magic
Spells Known: *Animal ally, control magical beast, summon beast, warding*
Corruption: 1 (troubled)
Insanity: Voices from the deep
Possessions: Loincloth, feathered head-dress, wide-bladed sword, pipes of madness

The master of the crawler is a Xotalanc sorcerer who ultimately brought about the doom of his people when he spearheaded an attempt to kill all of Tecuhtli, using the pipes of madness to gain entry into the western end of Xuchotl. He once controlled the crawler of Xuchotl until the crawler was slain by Conan the Cimmerian during the events of *Red Nails*.

PRINCE OLMEC OF TECUHTLI

Male Tlazitlan Barbarian 10/Noble 8
Medium Humanoid (Tlazitlan)
Hit Dice: 5d10+20 plus 5d8+20 plus 15 plus 6 (111 hit points)
Initiative: +17 (+4 Dex, +13 Reflex)
Speed: 30 ft. (6 squares)
Dodge Defence: 25 (+4 Dex, +10 level, +1 dodge)
Parry Defence: 22 (+5 Str, +7 level)
Damage Reduction: 1
Base Attack/Grapple: +16/+21
Attack: Unarmed strike +21 melee (1d6+5)
Full Attack: Unarmed strike +21/+16/+11/+6 melee (1d6+5)
Space/Reach: 5 ft. (1)/5 ft. (1)
Special Attacks: Crimson mist, versatility (no penalty)
Special Qualities: Bite sword, enhanced leadership, fearless, feud, improved uncanny dodge, lead by example +2, rank hath its privileges, social ability (refuge), special regional feature +2, title, Tlazitlan traits, trap sense +3, wealth
Saves: Fort +13, Ref +13, Will +12 (+11 vs. Corruption; +11 vs. Terror)
Abilities: Str 20, Dex 18, Con 18, Int 14, Wis 16, Cha 14
Skills: Bluff +14, Climb +18, Diplomacy +10, Gather Information +5, Hide +17, Intimidate +20, Jump +18,

On a wide ivory seat on a jade dais sat a man and a woman who differed subtly from the others. He was a giant, with an enormous sweep of breast and shoulders of a bull. Unlike the others, he was bearded, with a thick, blue-black beard which fell almost to his broad girdle. He wore a robe of purple silk which reflected changing sheens of colour with his every movement, and one wide sleeve, drawn back to his elbow, revealed a forearm massive with corded muscles. The band which confined his blue-black locks was set with glittering jewels.

Robert E. Howard, *Red Nails*



Knowledge (history) +6, Knowledge (local) +8, Listen +16, Move Silently +17, Profession (torturer) +6, Sense Motive +11, Spot +16, Survival +10, Tumble +5

Feats: Alertness, Brawl, Cleave, Combat Reflexes, Diehard, Dodge, Endurance, Fighting-Madness, Improved Grapple, Improved Mobility, Improved Unarmed Strike, Leadership, Mobility, Power Attack, Stealthy, Track

Code of Honour: None

Reputation: 22 (villain)

Leadership: 22/28 (11th level cohort; 8 3rd level, 4 4th level, 2 5th level, 1 6th level followers) (Note: There are not any

1st and 2nd level Tlazitlans available in Xuchotl to serve as followers).

Allegiances: Tecuhltli

Corruption: 1 (troubled)

Insanity: Paranoia

Possessions: Loincloth, purple silk robe with wide sleeves, jewelled headband, broad girdle

Prince Olmec ruled the Tecuhltli people until their extinction. He is a massive giant with powerful muscles and he has weird black eyes and a sardonic smile. His blue-black beard hangs down to his girdle. He will almost always use Power Attack with his mighty unarmed strikes.

He died grappling with Conan when the pair fell down a long flight of stairs. Conan crushed the life out of Olmec as they tumbled.

TECHOTL OF TECUHLTLI

Male Tlazitlan Barbarian 10

Medium Humanoid (Tlazitlan)

Hit Dice: 10d10+30 (85 hp)

Initiative: +13 (+3 Dex, +10 Reflex)

Speed: 30 ft. (6 squares)

Dodge Defence: 21 (+3 Dex, +7 level, +1 dodge)

Parry Defence: 17 (+4 Str, +3 level)

Damage Reduction: 1

Base Attack/Grapple: +10/+14

Attack: Wide-bladed sword +14 melee (1d10+4, 19-20, x2, AP 7)

Full Attack: Wide-bladed sword +14/+9 melee (1d10+4, 19-20, x2, AP 7)

Space/Reach: 5 ft. (1)/5 ft. (1)

Special Attacks: Crimson mist, versatility (no penalty)

Special Qualities: Bite sword, fearless, feud, improved uncanny dodge, Tlazitlan traits, trap sense +3

Saves: Fort +12, Ref +10, Will +5 (+4 vs. Corruption; +4 vs. Terror)

Abilities: Str 18, Dex 16, Con 16, Int 12, Wis 14, Cha 10

Skills: Bluff +4, Climb +10, Hide +11, Intimidate +15, Jump +10, Knowledge (local) +3, Listen +10, Move Silently +11, Profession (torturer) +6, Spot +9, Survival +8, Tumble +5

Feats: Alertness, Combat Reflexes, Diehard, Dodge, Endurance, Fighting-Madness, Great Fortitude, Mobility, Power Attack, Stealthy, Track

Code of Honour: None

Reputation: 10 (brave)

Leadership: –

Allegiances: Tecuhltli, Olmec

Corruption: 1 (troubled)

Insanity: Sleeplessness

Possessions: Loincloth, wide-bladed sword

Techotl has a repellent face and grotesquely muscular body. He wears a scanty silk clout that only partly covers his muscular hips and a leather girdle, about a hand's breadth wide, around his lean waist. He has long black hair that hangs in lank strands about his shoulders. He is gaunt with cords and knots of muscles without any of the fleshy padding that presents a pleasing symmetry of contour. The economy of his build is repellent and wild and his eyes blaze with madness. He befriended Conan and Valeria during the events covered in *Red Nails*.

TASCELA

Female Tlazitlan Scholar 17/ Temptress 2

Medium Humanoid (Tlazitlan)

Hit Dice: 10d6+20 plus 7 plus 2 (64 hit points)

Initiative: +18 (+5 Dex, +13 Reflex)

Speed: 30 ft. (6 squares)

Dodge Defence: 23 (+5 Dex, +7 level, +1 dodge)

Parry Defence: 17 (+1 Str, +6 level) or 20 (+4 Str*, +6 level)

Base Attack/Grapple: +13/+14 (+17*)

Attack: Dagger +18 melee finesse (1d4+1 (+4*), 19-20, x2, AP 2 (5*))

Full Attack: Dagger +18/+13/+8 melee finesse (1d4+1 (+4*), 19-20, x2, AP 2 (5*))

Space/Reach: 5 ft. (1)/5 ft. (1)

Special Attacks: Sorcery

Special Qualities: +4 power points, advanced spells x15, base Power Points, bonus spells x3, comeliness, dance of desire 1/day, feud, increased maximum Power Points (quadruple), knowledge is power, new sorcery style x6, savoir-faire, scholar, seductive art, Tlazitlan traits

Saves: Fort +7, Ref +13, Will +19 (+18 vs. Corruption; +18 vs. Terror)

Abilities: Str 12 (18*), Dex 21, Con 14, Int 17, Wis 18, Cha 23

Skills: Appraise +8, Bluff +14, Craft (alchemy) +20, Craft (herbalism) +20, Decipher Script +10, Diplomacy +19, Gather Information +11, Intimidate +30, Knowledge (arcana) +23, Knowledge (nature) +23, Knowledge (nobility) +13, Knowledge (local) +10, Move Silently +7, Perform (dance) +11, Perform (ritual) +23, Profession (torturer) +28, Sense Motive +12, Tumble +9, Use Rope +20

Feats: Dodge, Improved Grapple, Improved Unarmed Strike, Iron Will^B, Menacing Aura, Permanent Sorcery, Ritual Sacrifice, Steely Gaze, Tortured Sacrifice

Code of Honour: None

Reputation: 23 (villain)

Leadership: –

Allegiances: None

Base Power Points: 12 (4 base, +4 Wis, +4 bonus; 48 maximum)

Magical Attack: +14 (+8 level, +6 Cha)

She was tall and lithe, by far the most beautiful woman in the room. She was clad more scantily even than the others: for instead of a skirt she wore merely a broad strip of gilt-worked purple cloth fastened in the middle of her girdle which fell below her knees. Another strip at the back of her girdle completed that part of her costume, which she wore with cynical indifference. Her breast-plates and the circlet about her temples were adorned with gems. In her eyes alone of all the dark-skinned people there lurked no brooding gleam of madness.

Robert E. Howard, *Red Nails*

Sorcery Styles: Hypnotism, Curses, Counterspells, Divination, Immortality, Nature Magic

Spells Known: *Astrological prediction, curse of Yizil, domination, draw forth the soul, dream of wisdom, enslave, entrance, eternal youth, fruit of air, greater ill-fortune, greater warding, hypnotic suggestion, ill-fortune, incantation of Amalric's witchman, lesser ill-fortune, ranged hypnotism, savage beast, sorcerous garden, summon beast, torment, unnatural strength, visions, visions of torment and enlightenment, warding, witch's vigour*

Corruption: 5 (detached)

Insanity: None

Possessions: Narrow jewelled girdle (from which depends gilt-work purple cloth strips in front and back), jewelled breast-plate, jewelled circlet, thin gold-hilted dagger

* Tascela is usually under the influence of the *unnatural strength* spell; she renews the spell every 15 months or so.

Tascela is tall and lithe, the most beautiful woman among the Tlazitlans. She moves with a languid grace and is said to possess the secret of perpetual youth, claiming to have performed her *eternal youth* ritual nearly a thousand times. Olmec claims she is centuries old. He was a target of her *enslave* spell (from *Conan: The Scrolls of Skelos*).

She began her life as a temptress but when a Stygian priest taught her Hypnotism centuries ago, her life changed dramatically. The Nature Magic style was the last style she learned, when Tolkemec showed her how to cultivate *fruit of air*.

Tascela is an immoral, evil sorceress who does not allow women prettier than her to live long.

TOLKEMEC

Male Tlazitlan Barbarian 10/ Scholar 10

Medium Humanoid (Tlazitlan)

Hit Dice: 10d10+40 plus 10 (105 hit points)

Initiative: +18 (+4 Dex, +14 Reflex)

Speed: 30 ft. (6 squares)

Dodge Defence: 25 (+4 Dex, +10 level, +1 dodge)

Parry Defence: 20 (+4 Str, +6 level)

Damage Reduction: 2

Base Attack/Grapple: +17/+21

Attack: Unarmed strike +21 melee (1d4+4 nonlethal)

Full Attack: Unarmed strike +21/+16/+11/+6 melee (1d4+4 nonlethal)

Space/Reach: 5 ft. (1)/5 ft. (1)

Special Attacks: Crimson mist, versatility (no penalty)

Special Qualities: +3 Power Points, advanced spells x8, base Power Points, bite sword, bonus spells x2, fearless, feud, knowledge is power, improved uncanny dodge, increased maximum Power Points (triple), independent background, new sorcery style x4, obsession (revenge against Tecuhtli), scholar, Tlazitlan traits, trap sense +3

Saves: Fort +16, Ref +14, Will +15 (+14 vs. Corruption; +14 vs. Terror)

Abilities: Str 18, Dex 18, Con 18, Int 14, Wis 16, Cha 17

Skills: Bluff +7, Climb +14, Craft (alchemy) +9, Craft (herbalism) +22, Decipher Script +5, Handle Animal +13, Hide +24, Intimidate +18, Knowledge (arcana) +15, Knowledge (local) +15, Knowledge (nature) +21, Listen +16, Move Silently +20, Perform (ritual) +7, Profession (torturer) +9, Search +16, Survival +13

Feats: Alertness, Bleed Dry, Combat Reflexes, Diehard, Dodge, Endurance, Fighting-Madness, Great Fortitude, Improved Mobility, Iron Will, Mobility, Power Attack, Ritual Sacrifice, Stealthy, Tortured Sacrifice, Track

Code of Honour: None

Reputation: 23 (villain)

Leadership: –

Allegiances: None

Base Power Points: 7 (4 base, +3 Wis, +3 bonus, -3 obsession; 21 maximum)

Magical Attack: +10 (+7 level, +3 Cha)

Sorcery Styles: Counterspells, Nature Magic, Necromancy, Summonings

Spells Known: *Agonising doom, animal ally, children of the night, control magical beast, death touch, demonic pact, fruit of air, greater summon beast, greater warding, incantation of Amalric's witchman, raise corpse, sorcerous garden, summon beast, warding*

Corruption: 12 (corrupt)

Insanity: All of them

Possessions: Rags, wand of crimson fire

Tolkemec arrived at Xuchotl as a youth, the only survivor of a doomed expedition from Lake Zuad. Enslaved by the Old

Kosalans, he managed to start learning some of their ancient sorcery. When another expedition from Lake Zuad arrived at Xuchotl, he talked the brother rulers into slaughtering his enslavers, giving him any captives. After the Old Kosalans were killed, a hundred captives were given to Tolkemec to torture. Later, after the feud between the brothers broke out, Tolkemec worked both sides, betraying both repeatedly. When the Tecuhtli people broke into his southern citadel, his people were put to the sword and he was tortured and thrown into the catacombs of Tecuhtli where it was believed he perished.

Instead of perishing, Tolkemec, driven by an obsession for revenge, flourished upon the grisly fare he found in the catacombs. He sought out a powerful weapon and, years later, found it. Driven insane and no longer human, Tolkemec resurfaced at the end of *Red Nails* to slaughter his enemies. Conan slew him with a thrown knife.



XUCHOTL

Tolkemec cannot speak any longer and can only titter insanely.

TYPICAL TLAZITLAN WARRIORS OF XUCHOTL

Tlazitlan Barbarian 3: Medium Humanoid (Tlazitlan); Hit Dice: 3d10+3 (19 hp); **Initiative:** +7 (+2 Dex, +5 Reflex); **Speed:** 30 ft.; **Dodge Defence:** 15 (+2 Dex, +2 level, +1 dodge); **Parry Defence:** 13 (+2 Str, +1 level); **BAB/Grapple:** +3/+5; **Attack:** Wide-bladed sword +5 melee (1d10+2, 19-20, x2, AP 5); **Full Attack:** Wide-bladed sword +5 melee (1d10+2, 19-20, x2, AP 5); **Space/Reach:** 5 ft. (1)/5 ft. (1); **Special Attacks:** Crimson mist, versatility (-2 penalty); **Special Qualities:** Bite sword, fearless, feud, Tlazitlan traits, trap sense +1; **Saves:** Fort +4, Ref +5, Will +2 (+1 vs. Corruption; +1 vs. Terror); **Abilities:** Str 15, Dex 14, Con 13, Int 10, Wis 12, Cha 8; **Skills:** Bluff +2, Climb +4, Hide +5, Intimidate +4, Jump +8, Listen +7, Move Silently 5, Profession (torturer) +5, Spot +5, Survival +5; **Feats:** Dodge, Endurance, Fighting-Madness, Stealthy, Track; **Code of Honour:** None; **Reputation:** 2 (cruel); **Leadership:** -; **Allegiances:** Tecuhltli or Xotalanc; **Corruption:** 1 (troubled); **Insanity:** Any 1 insanity; **Possessions:** Loincloth or skirt, wide-bladed sword (women wear golden-breast plates and gem-crusted girdles).

Tlazitlan Barbarian 4: Medium Humanoid (Tlazitlan); Hit Dice: 4d10+4 (26 hp); **Initiative:** +8 (+2 Dex, +6 Reflex); **Speed:** 30 ft.; **Dodge Defence:** 16 (+2 Dex, +3 level, +1 dodge); **Parry Defence:** 14 (+3 Str, +1 level); **BAB/Grapple:** +4/+7; **Attack:** Wide-bladed sword +7 melee (1d10+3, 19-20, x2, AP 6); **Full Attack:** Wide-bladed sword +7 melee (1d10+3, 19-20, x2, AP 6); **Space/Reach:** 5 ft. (1)/5 ft. (1); **Special Attacks:** Crimson mist, versatility (-2 penalty); **Special Qualities:** Bite sword, fearless, feud, Tlazitlan traits, trap sense +1, uncanny dodge; **Saves:** Fort +5, Ref +6, Will +2 (+1 vs. Corruption; +1 vs. Terror); **Abilities:** Str 16, Dex 14, Con 13, Int 10, Wis 12, Cha 8; **Skills:** Bluff +3, Climb +5, Hide +6, Intimidate +5, Jump +10, Knowledge (local) +1, Listen +8, Move Silently +6, Profession (torturer) +5, Spot +6, Survival +5; **Feats:** Dodge, Endurance, Fighting-Madness, Stealthy, Track; **Code of Honour:** None; **Reputation:** 3 (cruel); **Leadership:** -; **Allegiances:** Tecuhltli or Xotalanc; **Corruption:** 1 (troubled); **Insanity:** Any 1 insanity; **Possessions:** Loincloth or skirt, wide-bladed sword (women wear golden-breast plates and gem-crusted girdles).

Tlazitlan Barbarian 5: Medium Humanoid (Tlazitlan); Hit Dice: 5d10+5 (32 hp); **Initiative:** +8 (+2 Dex, +6 Reflex); **Speed:** 30 ft.; **Dodge Defence:** 16 (+2 Dex, +3 level, +1 dodge); **Parry Defence:** 14

(+3 Str, +1 level); **BAB/Grapple:** +5/+8; **Attack:** Wide-bladed sword +8 melee (1d10+3, 19-20, x2, AP 6); **Full Attack:** Wide-bladed sword +8 melee (1d10+3, 19-20, x2, AP 6); **Space/Reach:** 5 ft. (1)/5 ft. (1); **Special Attacks:** Crimson mist, versatility (-2 penalty); **Special Qualities:** Bite sword, fearless, feud, Tlazitlan traits, trap sense +1, uncanny dodge; **Saves:** Fort +5, Ref +6, Will +2 (+1 vs. Corruption; +1 vs. Terror); **Abilities:** Str 16, Dex 14, Con 13, Int 10, Wis 12, Cha 8; **Skills:** Bluff +3, Climb +6, Hide +7, Intimidate +6, Jump +11, Knowledge (local) +2, Listen +9, Move Silently +7, Profession (torturer) +5, Spot +7, Survival +5; **Feats:** Alertness, Dodge, Endurance, Fighting-Madness, Mobility, Stealthy, Track; **Code of Honour:** None; **Reputation:** 4 (cruel); **Leadership:** -; **Allegiances:** Tecuhltli or Xotalanc; **Corruption:** 1 (troubled); **Insanity:** Any 1d2 insanities; **Possessions:** Loincloth or skirt, wide-bladed sword (women wear golden-breast plates and gem-crusted girdles).

Tlazitlan Barbarian 6: Medium Humanoid (Tlazitlan); Hit Dice: 6d10+12 (45 hp); **Initiative:** +9 (+2 Dex, +7 Reflex); **Speed:** 30 ft.; **Dodge Defence:** 17 (+2 Dex, +4 level, +1 dodge); **Parry Defence:** 15 (+3 Str, +2 level); **BAB/Grapple:** +6/+9; **Attack:** Wide-bladed sword +9 melee (1d10+3, 19-20, x2, AP 6); **Full Attack:** Wide-bladed sword +9/+4 melee (1d10+3, 19-20, x2, AP 6); **Space/Reach:** 5 ft. (1)/5 ft. (1); **Special Attacks:** Crimson mist, versatility (-2 penalty); **Special Qualities:** Bite sword, fearless, feud, Tlazitlan traits, trap sense +2, uncanny dodge; **Saves:** Fort +7, Ref +7, Will +3 (+2 vs. Corruption; +2 vs. Terror); **Abilities:** Str 17, Dex 15, Con 14, Int 11, Wis 13, Cha 9; **Skills:** Bluff +3, Climb +7, Hide +8, Intimidate +7, Jump +12, Knowledge (local) +2, Listen +10, Move Silently +8, Profession (torturer) +5, Spot +8, Survival +6; **Feats:** Alertness, Combat Reflexes, Diehard, Dodge, Endurance, Fighting-Madness, Mobility, Stealthy, Track; **Code of Honour:** None; **Reputation:** 5 (cruel); **Leadership:** -; **Allegiances:** Tecuhltli or Xotalanc; **Corruption:** 1 (troubled); **Insanity:** Any 1d2 insanities; **Possessions:** Loincloth or skirt, wide-bladed sword (women wear golden-breast plates and gem-crusted girdles).

The Tlazitlan warriors of Xuchotl are dark-skinned but not Negroid. They are grotesquely muscled, with their bodies having a bare minimum of body fat (probably contributing to the childlessness of the women for the past 15 years). These statistics are for males and females, as both are bred to a world of war and have no sexually defined roles as might be found in a normal society. The women are strange-eyed and weirdly beautiful. The men wear a silk loincloth and have black, lanky hair. The women wear sandals, golden breast-plates and scanty silk skirts supported by gem-crusted girdles. The hair of the women, cut square at their naked shoulders, is bound with silver circlets. The Tlazitlan warriors of Xotalanc paint white skulls on their chests.

VALERIA OF THE RED BROTHERHOOD

Female Aquilonian Pirate 7 / Soldier 2

Medium Humanoid (Aquilonian)

Hit Dice: 7d8+14 plus 2d10+4 (60 hp)

Initiative: +19 (+5 Dex, +10 Reflex, +4 Improved Initiative)

Speed: 30 ft. (6 squares)

Dodge Defence: 22/24 (+6 level, +5 Dex, +1 dodge, +2 seamanship if on ship)

Parry Defence: 17/19 (+4 level, +3 Str, +2 seamanship if on ship)

DR: –

Base Attack/Grapple: +7/+10

Attack: Arming sword +13 melee finesse (1d10+3, 19-20, x2, AP 5) or dagger +12 ranged (1d4+3, 19-20, x2, AP 4)

Full Attack: Arming sword +13/+8 melee (1d10+3, 19-20, x2, AP 5) and dagger +12 melee finesse (1d4+3, 19-20, x2, AP 4)

Special Attacks: Ferocious attack (additional attack), sneak attack +2d6, sneak subdual, to sail a road of blood and slaughter

Special Qualities: Adaptable (Bluff, Tumble), background skills (Appraise, Intimidate, Sense Motive, Tumble), bite sword, Hyborian traits, pirate code (Barachan rockets and smoke), seamanship +2, uncanny dodge

Space/Reach: 5 ft. (1)/5 ft. (1)

Saves: Fort +10, Ref +10, Will +3

Abilities: Str 16, Dex 20, Con 14, Int 13, Wis 12, Cha 15

Skills: Appraise +5, Balance +7*, Bluff +16, Climb +6*, Intimidate +7, Move Silently +15, Profession (sailor) +8*, Ride +6, Sense Motive +7, Spot +6, Tumble +15, Use Rope +6* (*Valeria gains a +2 bonus to these skills due to her *seamanship* quality when on a ship; these bonuses are not included in the previous values.)

Feats: Combat Expertise, Combat Reflexes, Dodge, Improved Disarm, Improved Feint, Improved Initiative, Leadership, Mobility, Weapon Focus (arming sword)

Code of Honour: None

Reputation: 33 (Brave)

Leadership: 11 (5th level cohort; 25 1st level followers) (Note: all followers and cohort dead currently)

Allegiances: None

Possessions: Arming sword, silk breeks, silken sash, leather boots, blouse, dagger

Valeria is a tall, full-bosomed, large-limbed Aquilonian woman with compact shoulders, reflecting unusual strength in her feminine appearance. Although she dresses and stands like a man, she is undoubtedly all woman. She wears short, wide-legged silk breeches, which cease a hand's breadth short of her knees. A wide silken sash is worn as a girdle. Flaring-topped boots of soft leather come almost to her knees. She also wears a low-necked, wide-collared, wide-sleeved silk shirt. She carries a straight, double-edged sword on one

hip and a long dirk on the other. Her unruly hair is golden and cut square at the shoulders. She confines her hair in a crimson satin band.

Valeria is one of the most infamous pirates of the Red Brotherhood of the Barachan Isles. She has commanded ships and led raiding parties all over the Argossean and Zingaran coast and beyond, up and down the Black Coast. She has also worked as a mercenary soldier, assisting the Stygians with the defence of the border city of Sukhmet.

Valeria's only real weaknesses are that men do not always take her seriously due to her beauty and that she is relatively inexperienced when it comes to land-based adventuring, though she is a real demon once aboard a ship. She is extremely wary of male attention, though she enjoys it and finds it flattering, she will not give in to it and thus give the man power over her. Any who try to take her by force will find themselves rapidly skewered on the end of a sword.



SKILLS AND FEATS



Exploring Ruins

THE ALLURE OF DANGER

THERE IS SOMETHING irresistible in the allure of decaying ruins and ancient places. They are testaments to ingenuity, yet the civilisations fell regardless of their creativity and intelligence. The ancient places of the world have an awesome power to impress and overwhelm the viewer in a way a newer place can never hope to have. The whole air of decay surrounding such places, the sheer sense of history pervading these old locations work to provide stimulus to the dark corners of the imagination and conjure ghosts unlike any said to haunt mankind.

For some, these locales hark back to the 'good-old days'; for others, the sense of nostalgia is more horrific, a lurking terror barely contained and best forgotten. For most, a sense of mystery is the strongest emotion perceived upon viewing the remnants of a dead culture. This sense of mystery comes from the imagined idea that there are undiscovered stories forever locked beyond our ken but worth finding, if the finding is possible. The sense of mystery is evident in the wonderings of scholars as they try to imagine how the people of that time lived, who they were and what they did – all the time knowing that their wonderings and imaginations are only speculation, subject to dispute and alternative theory; the truth always hidden from direct experience. The sense of mystery is seen when a thief braves the unknown to find a lost mummy or a bit of treasure hiding in hidden recesses and shadowed crypts.

In addition to being monuments to the skill and imagination of man in his attempts to impose order upon chaos and to impose civilisation upon wilderness, ancient ruins also remind the viewer of the inexorable approach of time, bringing about a doomed entropy of all civilisations, an inevitable disintegration of culture and value. Ultimately, the ruins tell the viewer that no matter what man does, all he will leave behind is ruin. Ruins in the Hyborian Age emphasise this tale of impending decline and ultimate fall with each appearance in a Howard tale – and so it should also with each appearance in *Conan the Roleplaying Game*. One of the recurring themes Howard put into his stories was that no matter what any one person or civilisation did, ruin was always around the corner. All a character can do in a Howard story is hold back the impending doom for a short while – he can never stop it from happening. As soon as a Howard

character stops striving the inevitable happens and everything that character upheld is washed away in a torrent of blood, fire and tribulation, leaving behind only decaying ruins as a testament to the attempt to turn back the tide. Eventually time even destroys these ruins, wearing the strongest of stone monuments down to mere hills, forgotten by the generations and lost forever, save as a footnote in some historian's scroll.

However, the theme of ultimate decay and crushing entropy is not the only theme at work in the Hyborian Age. Some races and peoples seem to manage to avoid the onslaught of time a little longer than they should. These are the lost races and lost cities, peoples whose stagnation illustrates the grim purpose behind the marching beat of time's destructive movements. The lost city theme is explored by Howard in many of his stories. Two wonderful examples are *The Voice of El-Lil* and *The Lost Valley of Iskander*. Conan himself encounters more than his share of lost cities in numerous Conan stories.

Conquered peoples who have fled their homeland to build a static city in foreign lands, utopias, lost tribes of the Sons of Shem and aboriginal remnants found in forgotten hills all have their place in Hyborian Age campaigns. In *The Hour of the Dragon*, Howard hints that descendants of the ancient Acheronians still live in the hills of Nemedia, a perfect seed for a lost city themed adventure. The mountains of Corinthia and the unexplored reaches of the Black Kingdoms are perfect for adventures with this theme. Some non-Howard stories with this theme that can be used for inspiration include several of Edgar Rice Burroughs' stories, such as *Tarzan and the Lost Empire* and *Tarzan and the Jewels of Opar*, and H. Rider Haggard's *Allan Quartermain*. Lost valleys filled with dinosaurs and extinct civilisations thrive in these sorts of adventures. Part of the fun of this sort of campaign is the chance to explore ideas that otherwise might be inappropriate to the known world.

Yet even for the lost city and the lost race, time is not to be thwarted for long. Usually the discovery of such lost places brings about the demise of the culture. The finding of something lost to time reminds entropy of its purpose and it usually returns to make sure the job is finished. Herein lie many such tales for the players and Games Masters of *Conan the Roleplaying Game* to experience first hand.

RUINS AND ADVENTURES

There are a lot of reasons people may want to explore a ruin. Here are some sample starting scenarios to bring an adventuring group together:

The Legend Trip: The characters are legend tripping, which is an adolescent rite of passage in which a night journey to a haunted location is made to prove the manhood of the adolescents involved. A barbaric tribe might even officially sanction such trips by requiring a member of the tribe to spend the night in such a location before the head of the tribe pronounces the tribesman a warrior. For example, a Southern Black Kingdom tribe might require a would-be warrior to spend the night at an elephant's graveyard or in a supposedly haunted section of jungle.

Awakening in Terror: The characters all wake up in a tomb (with or without equipment) with no explanation of where they are or how they got there. They may be in sarcophagi (with or without another corpse) or they may just be in a sepulchre. Are they reanimated corpses? Did they die? Did a sorcerer sacrifice them to some hideous doom? No one knows or remembers, but they quickly realise they need to escape the ruin and that they probably had better work together.

The Chase: Characters are chased by authorities, or other hostile parties into the ruin, which seems to offer the only chance for escape. Perhaps the authorities fear the ruin (such as the Picts chasing Conan in *The Black Stranger*) or perhaps the Player Characters just see an opportunity to ambush or lose the pursuers (such as in *The Hall of the Dead*).

The Last Survivors: The Player Characters are the last survivors of a battle and they find the ruin on the battlefield or near it. They may need shelter or rescue.

In Pursuit of a Girl: The characters chase after a girl into the wilderness, finding the ruin at the end of the journey (such as in *Red Nails* or *The Vale of Lost Women*). The Games Master could use a motif from *The Frost Giant's Daughter*, but instead of leading the characters deep into a frozen wasteland, the nymph character leads the Player Characters to a ruin. Perhaps only one character sees the nymph and the others are trying to keep up or stop this character, or perhaps they all see her and are maddened by the sight and follow her to the ruin.

The Nightmare From the Ruins: A nightmare or dream plagues the party or a single Player Character, starting the character or characters on a quest to end the dreams.

Bored, Bored, Bored: The characters are bored, lounging in the lap of luxury, when a slave girl whispers to them of a fabulous place they can visit – a ruin just brimming with legendary treasures.

Hijacked!: The Player Characters (who may or may not know each other initially) are on a ship toward some destination – but the ship is hijacked by someone intent on finding a lost island with weird ruins.

Marooned: A ship carrying the Player Characters has mutinied and the Player Characters are marooned on a remote island with a ruin.

Marooned by Sea-Battle or Storm: The characters have been in a heavy sea battle and were captured, but a storm has driven the ship into an uncharted island. Alternatively, the ship has simply been driven onto the uncharted island even without the battle. The Player Characters comprise most (if not all) of the survivors of the shipwreck.

ADVENTURE HOOKS

Of course, any of the legends associated with a ruin can serve as an adventure hook – but the search for treasure or a magical artefact may wear thin after a couple of adventures centred around such a goal. The characters should come across things that surprise them, and lost cities, ancient monsters and strange ruins appearing in the gloom should be part of the game. These hooks may serve as inspiration to find other reasons for a character to travel to an ancient ruin.

- ### A father suspects his wife is going to sacrifice one or more of his children to a demon at a local ruin and begs the player characters to intercede.
- ### An enterprising man is grave-robbing from a local ruin to fill the needs of a death cult devoted to necrophilia.
- ### A man is grave-robbing from a Stygian ruin to give the local apothecaries enough mummies to make potions and ointments from.
- ### A cult has set up operations in an old ruin and is making demands on the settlement where the Player Characters.
- ### A werewolf is stalking the shadowed streets of whatever city the Player Characters are in. Authorities believe the werewolf is one of the Player Characters. The Player Characters discover the true werewolf lives in a local ruin.
- ### A vampire has taken up residence in a ruin within or near the city where the Player Characters are and kills someone important to the Player Characters.

- ☼# A child important to the Player Characters is killed by a lamia and the Player Characters must track her to her ruinous lair.
- ☼# A *Spawn of Dagoth Hill* villain has risen to power and the Player Characters learn that the manner of his downfall can be found in the ruins on Dagoth Hill (or even some other ruin. The template from *Conan the Roleplaying Game* can apply to other ruins if desired).
- ☼# A sorcerer casts a spell resurrecting an ancient city that once existed on the site before the arrival of the current people. Player Characters must kill the sorcerer to return the town back to normal.
- ☼# A hauntingly beautiful Nordheimer woman is dancing at a tavern and each night she leads a dozen men to a local ruin and none of them are ever seen again. She is casting *dance of Atali* as she dances and leading the men to her demon lover (see *Conan: Scrolls of Skelos* for the spell description) at the ruin.
- ☼# A man gets even with his bothersome in-laws by having them kidnapped and left in a tomb or ruin, leaving him in peace. The Player Characters have to go rescue the bothersome in-laws – and after meeting them have to decide if they really *want* to rescue them at all!
- ☼# A girl's marriage to her lover is forbidden because her parents intend to sacrifice her to their demonic overlord in a diabolic wedding ceremony that will make her a queen of Hell. She begs the characters to intercede on her behalf but before they can, the parents haul the girl off to an ancient ruin to perform the ceremony.
- ☼# A powerful man (perhaps even a king) decides to get rid of one of his advisors, a scholar of repute. He has the man drowned, hanged, buried alive and other gruesome deaths, yet each time the scholar arrives for work the next morning as if nothing had happened. The player characters are hired to kill the advisor once and for all – they learn the only way to kill the advisor is to destroy a graven image of the man found in a far-off ruin.
- ☼# An earthquake levels part of an ancient ruin, including some of the defensive walls that, until now, deterred thieves. There is a rush to loot the ruin and the Player Characters are either part of the rush or charged with defending the ruin.
- ☼# A group of Picts, brought here from Pictland as a curiosity on the command of a noble, escape and begins raiding caravans from a local ruin.
- ☼# A noblewoman decides to marry but only wants the most brave and adventurous of husbands so she designs a quest for a fabulous object of myth and legend located in a ruin. The characters either have their own motivation to join the quest or are beseeched to enter the quest on behalf of another.
- ☼# A prince, princess or other aristocrat is kidnapped (and taken to a local ruin) and a reward posted, as well as a hefty bounty for the capture of the kidnapper.

Unfortunately, the victim has fallen in love with her captor and does not want to return to her sheltered, pampered life. If the characters allow the 'victim' to remain with her lover, an advisor to the aristocratic parents manages to implicate the characters as part of the crime and they are arrested by the aristocrats personal guard.

CAVE-INS OR COLLAPSES

A cave-in or collapse consists of two distinct areas: the bury zone (in the direct path of the falling debris) and the dust zone (the area the debris spreads out to encompass). Characters in the bury zone always take damage from the collapse; characters in the dust zone may be able to get out of the way. Characters in the bury zone take 8d6 points of damage, or half that amount if they make a Reflex save (DC 15). They are subsequently buried regardless of the save (see below). Characters in the dust zone take 3d6 points of damage, or no damage if they make a Reflex save (DC 15). Those who fail their saves are buried. Games Masters may also add falling damage to that if the characters were on top of the collapse.

Buried characters take 1d6 points of nonlethal damage per minute. If a buried character falls unconscious, he must make a Fortitude save (DC 15) or take 1d6 points of lethal damage each minute thereafter until freed or dead.

The dust zone of a collapse extends out past the bury zone at half the distance of the actual bury zone. For example, if a 40 foot long, 20 foot tall wall collapses, the dust zone extends out 20 feet out along the length of the fall and ten feet out past the head and foot of the wall.

If characters try to outrun the collapse, keep in mind the movement modifiers for the ruin based on the rubble or undergrowth level of the ruin (see Movement Within Ruins on page 22). Ruins typically have Difficult Terrain or Obstacles (see movement in *Conan the Roleplaying Game*). The dust zone moves at 500 feet per round (100 squares).

TRAPS

A trap can be either mechanical or magical in nature. Mechanical traps include pits, arrow traps, falling blocks, water-filled rooms, whirling blades, and anything else that depends on a mechanism to operate. A mechanical trap can be constructed by a Player Character through successful use of the Craft (trapmaking) skill (see Designing a Trap, below, and the skill description).

Ruins are frequently equipped with deadly mechanical (non-sorcerous) traps. A trap is typically defined by its location

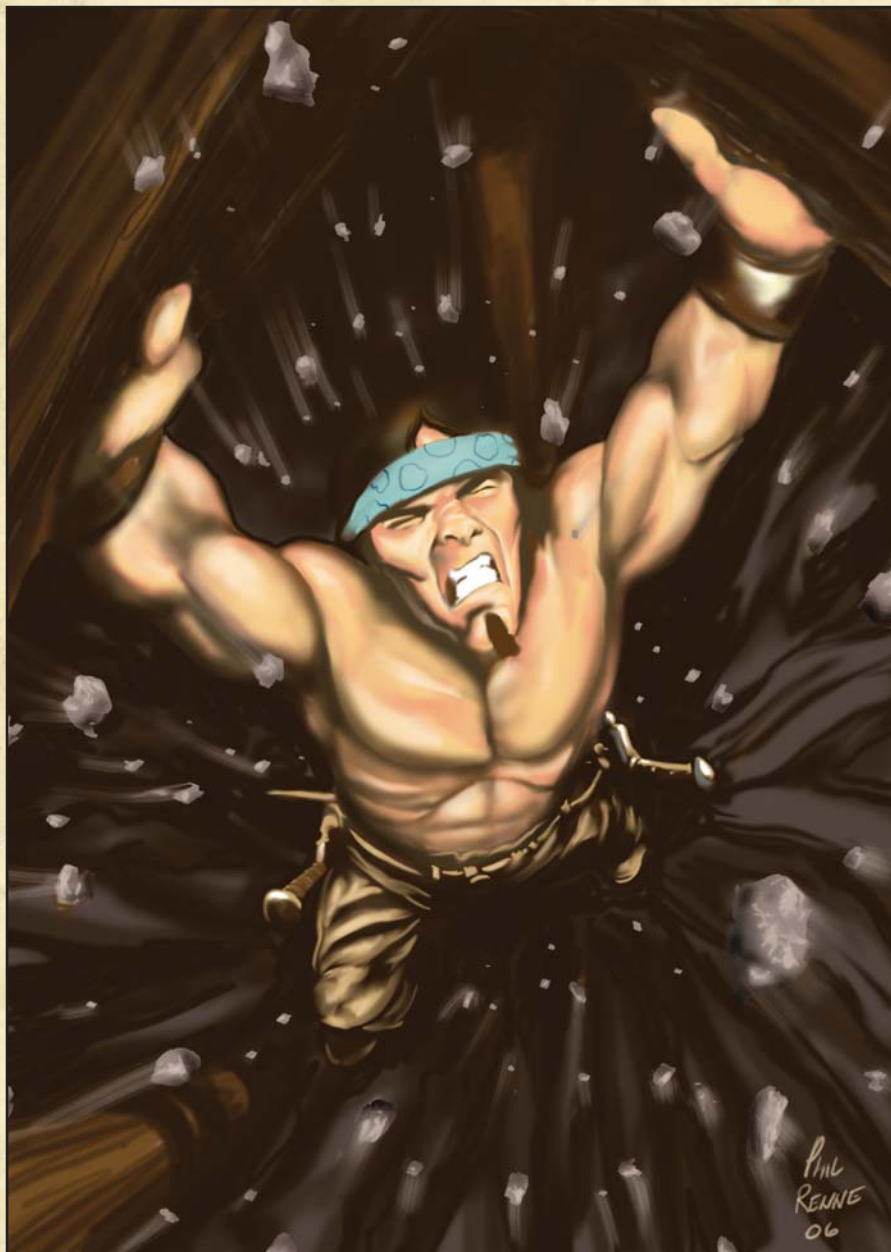

TRIGGER

A trap's trigger determines how it is sprung.

Location: A location trigger springs a trap when someone stands in a particular square.

Proximity: This trigger activates the trap when a creature approaches within a certain distance of it. A proximity trigger differs from a location trigger in that the creature need not be standing in a particular square. Creatures that are flying can spring a trap with a proximity trigger but not one with a location trigger. Mechanical proximity triggers are extremely sensitive to the slightest change in the air. This makes them useful only in places such as crypts, where the air is unusually still.

Touch: A touch trigger, which springs the trap when touched, is one of the simplest kinds of trigger to construct. This trigger may be physically attached to the part of the mechanism that deals the damage or it may not.

Timed: This trigger periodically springs the trap after a certain duration has passed.

RESET

A reset element is the set of conditions under which a trap becomes ready to trigger again.

No Reset: Short of completely rebuilding the trap, there's no way to trigger it more than once. Spell traps have no reset element.

Repair: To get the trap functioning again it must be repaired.

Manual: Resetting the trap requires someone to move the parts back into place. This is the kind of reset element most mechanical traps have.

Automatic: The trap resets itself, either immediately or after a timed interval.

and triggering conditions, how hard it is to spot before it goes off, how much damage it deals, and whether or not the heroes receive a saving throw to mitigate its effects. Traps that attack with arrows, sweeping blades and other types of weaponry make normal attack rolls, with a specific attack bonus dictated by the trap's design. Creatures who succeed on a Search check (DC 20) detect a simple mechanical trap before it is triggered.

All traps have the following elements: trigger, reset, Search DC, Disable Device DC, attack bonus (or saving throw or onset delay) and damage/effect. Some traps may also include optional elements, such as poison or a bypass. These characteristics are described below.



REPAIRING AND RESETTING MECHANICAL TRAPS

Repairing a mechanical trap requires a Craft (trapmaking) check against a DC equal to the one for building it. The cost for raw materials is one-fifth of the trap's original market price. To calculate how long it takes to fix a trap, use the same calculations used for building it, but use the cost of the raw materials required for repair in place of the market price.

Resetting a trap usually takes only a minute or so. For a trap with a more difficult reset method, you should set the time and labour required.

Bypass (Optional Element)

If the builder of a trap wants to be able to move past the trap after it is created or placed, it is a good idea to build in a bypass mechanism – something that temporarily disarms the trap. Bypass elements are typically used only with mechanical traps; spell traps usually have built-in allowances for the caster to bypass them.

Lock: A lock bypass requires an Open Lock check (DC 30) to open.

Hidden Switch: A hidden switch requires a Search check (DC 25) to locate.

Hidden Lock: A hidden lock combines the features above, requiring a Search check (DC 25) to locate and an Open

Lock check (DC 30) to open.

Search and Disable Device DCs

The builder sets the Search and Disable Device DCs for a mechanical trap. The base DC for both Search and Disable Device checks is 20.

ATTACK BONUS/SAVING THROW DC

A trap usually either makes an attack roll or forces a saving throw to avoid it. Occasionally a trap uses both of these options, or neither (see Never Miss).

Pits: These are holes (covered or not) that characters can fall into and take damage. A pit needs no attack roll, but a successful Reflex save (DC set by the builder) avoids it. Other save-dependent mechanical traps also fall into this category.

Pits in dungeons come in three basic varieties: uncovered, covered and chasms. Pits and chasms can be defeated by judicious application of the Climb skill, the Jump skill or various magical means.

Uncovered pits serve mainly to discourage intruders from going a certain way, although they cause much grief to characters who stumble into them in the dark, and they can greatly complicate a melee taking place nearby.

Covered pits are much more dangerous. They can be detected with a Search check (DC 20), but only if the character is taking the time to carefully examine the area before walking across it. A character who fails to detect a covered pit is still entitled to a Reflex save (DC 20) to avoid falling into it. However, if he was running or moving recklessly at the time, he gets no saving throw and falls automatically.

Trap coverings can be as simple as piled refuse (straw, leaves, sticks, garbage), a large rug, or an actual trapdoor concealed to appear as a normal part of the floor. Such a trapdoor usually swings open when enough weight (usually about 50 to 80 pounds) is placed upon it. Devious trap builders sometimes design trapdoors so that they spring back shut after they open. The trapdoor might lock once it is back in place, leaving the stranded character well and truly trapped. Opening such a trapdoor is just as difficult as opening a regular door (assuming the trapped character can reach it), and a Strength check (DC 13) is needed to keep a spring-loaded door open.

Pit traps often have something nastier than just a hard floor at the bottom. A trap designer may put spikes, monsters, or a pool of acid, lava or even water at the bottom. Spikes at the bottom of a pit deal damage as daggers with a +10 attack bonus and a +1 bonus on damage for every 10 feet of the fall (to a maximum bonus on damage of +5). If the pit has multiple spikes, a falling victim is attacked by 1d4 of them. This damage is in addition to any damage from the fall itself.

Monsters sometimes live in pits. Any monster that can fit into the pit might have been placed there by the dungeon's designer, or might simply have fallen in and not been able to climb back out.

A secondary trap, mechanical or magical, at the bottom of a pit can be particularly deadly. Activated by a falling victim, the secondary trap attacks the already injured character when he is least ready for it.

Ranged Attack Traps: These traps fling darts, arrows, spears, or the like at whoever activated the trap. The builder sets the attack bonus. A ranged attack trap can be configured to simulate the effect of a composite bow with a high strength rating which provides the trap with a bonus on damage equal to its strength rating.

Melee Attack Traps: These traps feature such obstacles as sharp blades that emerge from walls and stone blocks that fall from ceilings. Once again, the builder sets the attack bonus.

DAMAGE/EFFECT

The effect of a trap is what happens to those who spring it. Usually this takes the form of either damage or a spell effect, but some traps have special effects.

Pits: Falling into a pit deals 1d6 points of damage per 10 feet of depth.

Ranged Attack Traps: These traps deal whatever damage their ammunition normally would. If a trap is constructed with a high strength rating, it has a corresponding bonus on damage.

Melee Attack Traps: These traps deal the same damage as the melee weapons they 'wield'. In the case of a falling stone block, you can assign any amount of bludgeoning damage you like, but remember that whoever resets the trap has to lift that stone back into place.

A melee attack trap can be constructed with a built-in bonus on damage rolls, just as if the trap itself had a high Strength score.

Special: Some traps have miscellaneous features that produce special effects, such as drowning for a water trap or ability damage for poison. Saving throws and damage depend on the poison or are set by the builder, as appropriate.

MISCELLANEOUS TRAP FEATURES

Some traps include optional features that can make them considerably more deadly. The most common features are discussed below.

Alchemical Item: Mechanical traps may incorporate alchemical devices or other special substances or items, such as Acheronian demon-fire, flame-powder, Kothic demon-fire, lotus-smoke, Stygian tomb-dust, and the like.

Gas: With a gas trap, the danger is in the inhaled poison it delivers. Traps employing gas usually have the never miss and onset delay features (see below).

Liquid: Any trap that involves a danger of drowning is in this category. Traps employing liquid usually have the never miss and onset delay features (see below).

Multiple Target: Traps with this feature can affect more than one character.

Never Miss: When the entire dungeon wall moves to crush a character and his quick reflexes will not help, since the wall cannot possibly miss. A trap with this feature has neither an attack bonus nor a saving throw to avoid, but it does have an onset delay (see below). Most traps involving liquid or gas are of the never miss variety.

Onset Delay: An onset delay is the amount of time between when the trap is sprung and when it deals damage. A never miss trap always has an onset delay.

Poison: Traps that employ poison are deadlier than their non-poisonous counterparts. Only injury, contact and inhaled poisons are suitable for traps; ingested types are not. Some traps simply deal the poison's damage. Others deal damage with ranged or melee attacks as well.

Pit Spikes: Treat spikes at the bottom of a pit as daggers, each with a +10 attack bonus. The damage bonus for each spike is +1 per 10 feet of pit depth (to a maximum of +5). Each character who falls into the pit is attacked by 1d4 spikes.

Pit Bottom: If something other than spikes waits at the bottom of a pit, it is best to treat that as a separate trap with a location trigger that activates on any significant impact, such as a falling character.

SAMPLE TRAPS

Basic Arrow Trap: Mechanical; proximity trigger; manual reset; Atk +10 ranged (1d6/x3, arrow); Search DC 20; Disable Device DC 20.

Bricks from Ceiling: Mechanical; touch trigger; repair reset; Atk +12 melee (2d6, bricks); multiple targets (all targets in two adjacent 5-ft. squares); Search DC 20; Disable Device DC 20.

Built-to-Collapse Wall: Mechanical; proximity trigger; no reset; Atk +20 melee (8d6, stone blocks); multiple targets (all targets in a 10-ft.-by-10-ft. area); Search DC 14; Disable Device DC 16.

Ceiling Pendulum: Mechanical; timed trigger; automatic reset; Atk +15 melee (2d10+8/x3/ AP 13, bardiche); Search DC 15; Disable Device DC 27

Compacting Room: Mechanical; timed trigger; automatic reset; hidden switch bypass (Search DC 25); walls move together (12d6, crush); multiple targets (all targets in a 10-ft.-by- 10-ft. room); never miss; onset delay (4 rounds); Search DC 20; Disable Device DC 22.

Collapsing Column: Mechanical; touch trigger (attached); no reset; Atk +15 melee (6d6, stone blocks); Search DC 20; Disable Device DC 24.

Crushing Room: Mechanical; location trigger; automatic reset; walls move together (16d6, crush); multiple targets (all targets in a 10-ft.-by-10-ft. room); never miss; onset delay (2 rounds); Search DC 22; Disable Device DC 20.

Crushing Wall Trap: Mechanical; location trigger; automatic reset; no attack roll required (18d6, crush); Search DC 20; Disable Device DC 25.

Drawer Handle Smearred with Contact Poison: Mechanical; touch trigger (attached); manual reset; poison; Search DC 18; Disable Device DC 26 (see *Conan the Roleplaying Game* and/or *Conan: Hyboria's Fallen* for lists of contact poisons).

Dropping Ceiling: Mechanical; location trigger; repair reset; ceiling moves down (12d6, crush); multiple targets (all targets in a 10-ft.-by-10-ft. room); never miss; onset delay (1 round); Search DC 20; Disable Device DC 16.

Falling Acheronian Demon-Fire Trap: Mechanical; location trigger; manual reset; Atk +15 melee (1d6 fire damage + incapacitation for 1d6 rounds, Fort DC 25 to avoid incapacitation); multiple targets if it misses initial target (can strike all characters in two adjacent specified squares for 1 point of fire damage plus stun for 1d4 rounds, Reflex DC 20 to avoid damage and stun); Search DC 20; Disable Device DC 25.

Falling Flame-Powder Trap: Mechanical; location trigger; manual reset; Atk +15 melee (1d4 fire damage); multiple targets if it misses initial target (can strike all characters in one adjacent specified square for 1d4 fire damage); Search DC 20; Disable Device DC 25

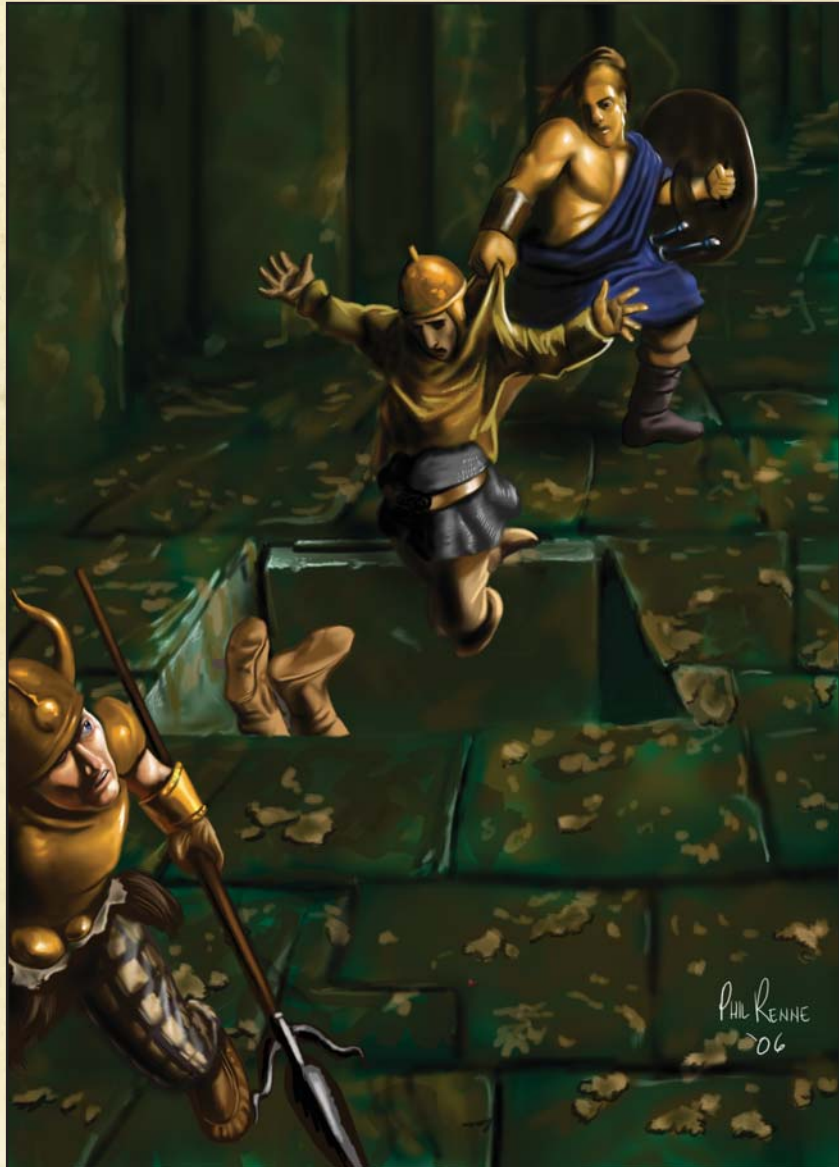

Falling Kothic Demon-Fire Trap: Mechanical; location trigger; manual reset; Atk +15 melee (5d8 fire damage plus Stun for one round, Fortitude DC 20 to avoid stun effect); multiple targets if it misses initial target (can strike all characters in two adjacent specified squares for 2d8 fire damage, Reflex DC 20 to avoid damage); Search DC 20; Disable Device DC 25.

Falling Block Trap: Mechanical; location trigger; manual reset; Atk +15 melee (6d6); multiple targets (can strike all characters in two adjacent specified squares); Search DC 20; Disable Device DC 25.

Fusillade of Poisoned Darts: Mechanical; location trigger; manual reset; Atk +18 ranged (1d4+1 plus poison, dart); poison; multiple targets (1d8 darts per target in a 10-ft.-by-10-ft. area); Search DC 25; Disable Device DC 25 (see

Conan the Roleplaying Game and/or *Conan: Hyboria's Fallen* for lists of poisons).

Fusillade of Spears: Mechanical; proximity trigger; repair reset; Atk +21 ranged (1d8, spear); multiple targets (1d6 spears per target in a 10-ft.-by-10-ft. area); Search DC 26; Disable Device DC 20.

Insanity Mist Vapour Trap: Mechanical; location trigger; repair reset; gas; never miss; onset delay (1 round); poison (grey lotus blossom, DC 22 Fortitude save resists, 2d6 Wis + Fighting Madness/1d6 Wis); multiple targets (all targets in a 10-ft.-by-10-ft. room); Search DC 25; Disable Device DC 20.

Javelin Trap: Mechanical; location trigger; manual reset; Atk +16 ranged (1d6+4, javelin); Search DC 20; Disable Device DC 18.

Large Net Trap: Mechanical; location trigger; manual reset; Atk +5 melee (see note); Search DC 20; Disable Device DC 25. *Note:* Characters in 10-ft. square are grappled by net (Str 18) if they fail a DC 14 Reflex save.

Lock Covered in Poison: Mechanical; touch trigger (attached); no reset; poison; Search DC 27; Disable Device DC 16 (see *Conan the Roleplaying Game* and/or *Conan: Hyboria's Fallen* for lists of contact poisons).

Lotus Smoke Trap: Mechanical; location trigger; repair reset; gas; multiple targets (all targets in a 10-ft.-by-10-ft. room); never miss; onset delay (3 rounds); poison (green, grey or black lotus smoke; see *Conan the Roleplaying Game* for effects of each); Search DC 21; Disable Device DC 21.

Moving Executioner Statue: Mechanical; location trigger; automatic reset; hidden switch bypass (Search DC 25); Atk +16 melee (2d10+8/x3/ AP 13, bardiche); multiple targets (both arms attack); Search DC 25; Disable Device DC 18

Poison Dart Trap: Mechanical; touch trigger; manual reset; Atk +8 ranged (1d4 plus poison, dart); poison (bloodroot, DC 12 Fortitude save resists, 0/1d4 Con plus 1d3 Wis); Search DC 20; Disable Device DC 18 (see *Conan the Roleplaying Game* and/or *Conan: Hyboria's Fallen* for lists of poisons).

Poison Needle Trap: Mechanical; touch trigger; manual reset; Atk +8 ranged (1 plus poison); Search DC 22; Disable Device DC 20 (see *Conan the Roleplaying Game* and/or *Conan: Hyboria's Fallen* for lists of poisons).

Poison Wall Spikes: Mechanical; location trigger; manual reset; Atk +16 melee (1d8+4 plus poison, spike); multiple targets (closest target in each of two adjacent 5-ft. squares); poison; Search DC 17; Disable Device DC 21 (see *Conan the*

Roleplaying Game and/or *Conan: Hyboria's Fallen* for lists of poisons).

Portcullis Trap: Mechanical; location trigger; manual reset; Atk +10 melee (3d6); Search DC 20; Disable Device DC 20. *Note:* Damage applies only to those underneath the portcullis. Portcullis blocks passageway.

Razor-Wire across Hallway: Mechanical; location trigger; no reset; Atk +10 melee (2d6, wire); multiple targets (first target in each of two adjacent 5-ft. squares); Search DC 22; Disable Device DC 15.

Rolling Rock Trap: Mechanical; location trigger; manual reset; Atk +10 melee (2d6, rock); Search DC 20; Disable Device DC 22.

Scything Blade Trap: Mechanical; location trigger; automatic reset; Atk +8 melee (1d8/x3); Search DC 21; Disable Device DC 20.

Spiked Blocks from Ceiling: Mechanical; location trigger; repair reset; Atk +20 melee (6d6, spikes); multiple targets (all targets in a 10-ft.-by-10-ft. area); Search DC 24; Disable Device DC 20.

Spiked Pit Trap: Mechanical; location trigger; manual reset; DC 25 Reflex save avoids; 40 ft. deep (4d6, fall); multiple targets (first target in each of two adjacent 5-ft. squares); pit spikes (Atk +10 melee, 1d4 spikes per target for 1d4+4 each); Search DC 21; Disable Device DC 20.

Swinging Block Trap: Mechanical; touch trigger; manual reset; Atk +5 melee (4d6, stone block); Search DC 20; Disable Device DC 20.

Tripping Chain: Mechanical; location trigger; automatic reset; multiple traps (tripping and melee attack); Atk +15 melee (trip), Atk +15 melee (2d4+2, spiked chain); Search DC 15; Disable Device DC 18.

Wall Blade Trap: Mechanical; touch trigger; automatic reset; hidden switch bypass (Search DC 25); Atk +10 melee (2d4/x4, scythe); Search DC 22; Disable Device DC 22.

Wall Scythe, Poisoned: CR 8; mechanical; touch trigger; manual reset; Atk +16 melee (2d4+8 plus poison, scythe); poison; Search DC 24; Disable Device DC 19 (see *Conan the Roleplaying Game* and/or *Conan: Hyboria's Fallen* for lists of contact poisons).

Water-Filled Room: Mechanical; location trigger; manual reset; multiple targets (all targets in a 10-ft.-by-10-ft. room); never miss; onset delay (3 rounds); water; Search DC 20; Disable Device DC 25.



Well-Camouflaged Pit Trap: Mechanical; location trigger; repair reset; DC 25 Reflex save avoids; 70 ft. deep (7d6, fall); multiple targets (first target in each of two adjacent 5-ft. squares); Search DC 27; Disable Device DC 18.

Wide-Mouth Pit Trap: Mechanical; location trigger; manual reset; DC 25 Reflex save avoids; 100 ft. deep (10d6, fall); multiple targets (all targets within a 10-ft.-by-10-ft. area); Search DC 25; Disable Device DC 25.

Wide-Mouth Spiked Pit with Poisoned Spikes: Mechanical; location trigger; manual reset; hidden lock bypass (Search DC 25, Open Lock DC 30); DC 20 Reflex save avoids; 70 ft. deep (7d6, fall); multiple targets (all targets within a 10-ft.-by-10-ft. area); pit spikes (Atk +10 melee, 1d4 spikes per target for 1d4+5 plus poison each);

poison; Search DC 20; Disable Device DC 20 (see *Conan the Roleplaying Game* and/or *Conan: Hyboria's Fallen* for lists of poisons).

Wide-Mouth Spiked Pit with Poisoned Spikes and Grey Lotus Dust: Mechanical; location trigger; manual reset; hidden lock bypass (Search DC 25, Open Lock DC 30); DC 20 Reflex save avoids; 20 ft. deep (2d6, fall); multiple targets (all targets within a 10-ft.-by-10-ft. area); pit spikes (Atk +10 melee, 1d4 spikes per target for 1d4+5 plus poison each); poison (see *Conan the Roleplaying Game* and/or *Conan: Hyboria's Fallen* for lists of poisons); grey lotus dust spews up when characters hit bottom (DC 22 Fortitude save resists, 2d6 Wis + Fighting Madness/1d6 Wis); Search DC 20; Disable Device DC 20.

HEAPS OF JEWELS IN A CARELESS RIOT OF SPLENDOUR

Treasures in *Conan the Roleplaying Game* should never just amount to 12,000 gold pieces; 3,000 silver pieces; and a handful of gems. Part of the appeal of treasure is the exoticness of it all. *Conan the Roleplaying Game* is not about two 2,000 sp diamonds, three 50 sp opals, etc.

Conan is about 'heaps of jewels in a careless riot of splendour'. Thus there are no values for these treasures. The characters get what they can sell them for. Odds are, the selling will happen offstage, in between games, and most of it lost in debauchery anyway.

TYPES OF TREASURE

Treasure can be in minted coins of precious metals – gold and silver are the most common, but copper, platinum and other metals are not unknown. However, gold, silver and other precious metals do not have to be minted to be valuable. The Æsir use hack-silver, in which the precious metal takes the form of a bracer or bracelet and the character simply slices off the weight he needs to purchase an item. Precious metals can also be in ingot form or in some other geometric shape. Take a look at the dice used in the game – gold and silver can be made into such shapes and imagine the exoticness of a stack of gold all forged into the shape of a d12 or d4!

Anything of value can be treasure, not just gold. Paper treasures can also be found. Writs of consignment, certificates granting permission to build castles or to add battlements to a manor-house, ancient scrolls, old libraries, stone tablets and other written goods can constitute treasure. See also the list of artefacts on page 17. Other treasures can include:

Arms: The ruin has an armoury of weapons suitable to its country of origin.

Armour: The ruin contains moulding jerkins, shirts and hauberks made by ancient craftsmen.

Lotus: This treasure may include black, golden, green, grey, purple, white or yellow lotus.

Gems: A chest of rubies, emeralds, pearls and other rare stones.

Grain: A cargo hold full of dried grain. These cargos are often used to mask more interesting, and valuable, cargos.

Incense: A cargo hold full of aromatics, including several kinds of mixed incense.

Ivory: The raw tusks of elephants. Ivory is valued all over the world, although its largest market is currently the Hyborian nations.

Raw Metal: The exact contents and type of raw metal must be defined when the Games Master places it. The metal has not yet been worked; instead it was headed to a larger market where craftsmen were more plentiful when the civilisation died.

Regional Goods: A hold full of local worked goods (shoes, boots, belts, silverware, bells, etc). A load of regional goods taken to another region becomes exotic goods. Regional goods belonging to a ruin are exotic almost anywhere.

Semi-precious Stones: A chest full of semi-precious stones (lapis-lazuli, opals, topaz, etc.).

Silk: A hold full of bolts of silk cloth. Silk is very common in the East (where it is the regional cloth) but hardly seen at all in the west.

Silver: A chest full of raw and worked silver.

Spices: A small chest full of spices, worth their weight in gold.

FIFTY SAMPLE HYBORIAN AGE TREASURES

1. Cloth of gold scabbards
2. Gem crusted armour
3. Goblet carved from a single jewel
4. Gold dust, collected in bags
5. Gold dust, strewn over the floor, either a light dusting or inches deep
6. Gold wedges piled into pyramids
7. Golden helmets with black and scarlet plumes
8. Golden helmets with coloured horsehair crests
9. Jewel-hilted swords
10. Necklace: Human teeth set with jewels
11. Silver ingots
12. Silver scaled corselets
13. Skull plated with moonstones for eyes
14. Statue of jade
15. Bracelets of jet
16. Necklace of lapis lazuli
17. Chairs of ebony and ivory
18. Zamorian diamond goblet
19. Copper Shemitish god
20. Tapestries from Iranistan
21. Tapestries from Vendhya
22. Tapestries from Turan
23. Great ebony table
24. Ivory pedestal
25. Great jewel emanating a dim glow
26. Thick iron-bound chests
27. Bottles of ancient wine
28. Gilt-embroidered coats with jewelled buttons
29. Heaps of fantastically cut gems
30. Silver bound mahogany chests, sealed with heavy golden locks
31. Exotic incense
32. Lotus blossoms (choose a variety)
33. Bales of silk
34. Porcelain vases/dragons/sculptures from Khitai
35. Ancient scrolls
36. Ancient clay tablets with esoteric writing
37. Dried mummies, human
38. Dried mummies, animal
39. Dried mummy holding scroll or tablet
40. Green statuette of a serpent, its head upraised
41. Black basalt altar
42. Statues of horrific aspect
43. Strange black cylinder with a heavy, carven lid. Four feet tall and three feet in diameter at the point of widest circumference, about half-way up its height.

*'Prepare for disappointment,' said 'Publius.'
The value of such baubles ever gains in the
telling but shrinks in the selling.'*

L. Sprague de Camp & Lin Carter, *Conan
the Liberator*

44. Enormous strings of black pearls, like those worn by the dancers of the Spider-God.
45. Akbitanan weapons
46. Pot-bellied bronze statue of lewd Shemitish god or goddess with exaggerated features
47. Æsir coat sewn with coins and enemy teeth
48. Pictish ju-ju rattle, with finger-bones and feathers attached
49. Ivory statuette of Ishtar
50. Black lotus powder

FEATS OF THE TOMB-RAIDERS

Most tomb-raiders find it useful to have ranks in Climb (Str), Decipher Script (Int), Disable Device (Int), Jump (Str), Knowledge (religion) (Int), Listen (Wis), Move Silently (Dex), Search (Int), Swim (Str) and Use Rope (Dex). In addition to such skills, characters intent on raiding tombs and ruins may also find the following feats useful:

NERVES OF STEEL (GENERAL)

You have witnessed many strange things during the course of their work.

Prerequisite: You have survived encounters with ghouls, zombies or other undead creatures.

Benefit: These experiences grant you steady nerves, giving you a +2 bonus to all saves against fear-based effects, including Terror of the Unknown.

CALM OF THE DEAD (GENERAL)

Your calm demeanour allows you to absorb the sharpest psychic shock with seeming disinterest. While others panic, you go about your duties without fear.

Prerequisites: Nerves of Steel, Con 12+

Benefit: Once per day, you can opt to delay the onset of any fear- or terror-based effects by a number of rounds equal to your Constitution bonus. At the end of this interval, the fear-based effect functions as normal.

NECROMANTIC LORE (GENERAL)

Due to your repeated exposure to many strange events and bizarre magical effects, you gain an almost intuitive insight to the workings of dark magic that often protect tombs and ruins.

Prerequisites: Nerves of Steel, Calm of the Dead

Benefit: You can make Knowledge (arcana) checks as if you had maximum ranks (character level +3) in that skill in regards to anything related to a tomb or ancient ruin. In addition, once per day you can gain a +10 insight bonus on such a skill check. You recall a specific detail from past experiences that gives you an important revelation about the topic at hand.



Monsters of the Ruins

UNIQUE HORRORS IN THE DEEP

MONSTERS IN CONAN *the Roleplaying Game* should never become standard fare, at least not in the sense that they do in most fantasy roleplaying games. The monsters in the ruins should not be just another black fiend, just another giant spider, just another man-ape or just another dinosaur. If players recognise the monsters, they lose their mystery and horror, not to mention the element of danger.

This section introduces a method of modifying existing monsters to make them appear unique. The Games Master alone knows, for example, that blobby demon with the head of a slug and six eyes that squishes with each step is just a black fiend from *Conan the Roleplaying Game* with a different description. To the players, this demon is something new. Every monster should appear to be, unique and previously unknown. Sometimes all it takes is a few cosmetic changes – it is not necessary to create a new statistic block for each and every monster. Alter its appearance and actions and, as far as the players go, it is a new monster. Select or roll randomly on the tables provided, discarding rolls that would make the monster appear silly or incongruous.

Variations

d20	Result
01-02	Skin Variations
03	Face Variations
04	Mouth Variations
05	Nose Variations
06	Eye Variations
07-08	Ear Variations
09	Arm Variations
10-11	Leg Variations
12-13	Tail Variations
14	Colour Variations
15	Miscellaneous Trait Variations
16-17	1d6 variations
18-19	1d10 variations
20	One variation from each category

Skin Variations

d20	Result
01	Bloppy, fat, soft
02	Bony plates
03	Drippy, running slime
04	Fish scales
05	Human skin
06	Knobbly protrusions
07	Lizard scales (+1 to DR)
08	Long, tangled fur/hair
09	Outer shell/chitin (+1 to DR)
10	Scars, burns, wounds
11	Short, bristly hair
12	Slimy, covered in mucous
13	Sparse, patchy hair
14	Spikes
15	Thick fur (+1d2 to DR)
16	Thick, stony skin (+1d4 to DR)
17	Tough, thick, leathery (+1d6 to DR)
18	Transparent skin
19	Weeping sores
20	Wrinkled, leathery skin



Face Variations

d20	Result
01	Angular features
02	Bat-like
03	Bird-like
04	Blank, featureless
05	Canine
06	Elephantine
07	Equine
08	Feline
09	Fish-like
10	Humanoid
11	Mollusc-like
12	Nose Variations
13	Rat-like
14	Lizard-like
15	Saurian (Theropod)
16	Saurian (Ceratopsid)
17	Saurian (Sauropod)
18	Serpentine
19	Spherical nodules
20	Squid-like

Mouth Variations

d20	Result
01	Beak
02	Expandable mouth
03	Fanged
04	Huge mouth dominating the face
05	Interior maw inside of exterior mouth
06	Lamprey mouth
07	Large mouth
08	Long tongue
09	Mandibles on either side of mouth
10	Mouth in unusual place
11	Mouth is a tube that sucks up food. Adds acid spit attack (range increment 10 feet; A direct hit deals 1d8 points of acid damage. Every creature within 5 feet of the point where the acid hits takes 1 point of acid damage from the splash.)
12	Mouth on a stalk (add bite attack)
13	Mouth surrounded by tentacles with suckers
14	No lips
15	No mouth
16	No teeth
17	Saw-toothed (can grapple and increase its AP by 1 per round of continued grapple as it saws through armour)
18	Small mouth
19	Telescoping mouth (5' reach beyond normal reach)
20	Tusks (adds gore attack)



Nose Variations

d20	Result
01-02	Canine nose
03-04	Drooping, hanging snout
05-06	More than one nose
07-08	Narrow nose
09-10	No discernable nose
11-12	Nose slits only
13-14	Prehensile trunk
15-16	Protruding more than normal
17-18	Warty nose
19-20	Wider than normal

Eye Variations

d20	Result
01	+1d6 eyes
02	Colour Variation
03	Eyes in an abnormal place
04	Eyes reflect galaxies and eons
05	Fly eyes
06	Fewer eyes than normal
07-08	Fish-eyed
09-10	Huge
11	Human eyes on animal
12	No eyes
13	Protruding
14	Round
15-16	Slitted
17	Small
18	Squinting
19	Stalked
20	Sunken

Ear Variations

d20	Result
01-02	+1d6 ears
03	Animal ears on humanoid
04	Ears in an abnormal place
05	Elephantine ears
06	Fan-like ears
07-08	Fewer ears than normal
09-10	Huge ears
11	Human ears on animal
12-13	Knobbly ears
14	No ears
15-16	Pointed ears
17	Protruding ears
18	Round holes for ears
19	Small ears
20	Stalked ears

Head Adornment

d12	Result
01	Antlers
02	Crest
03	Hair, long
04	Hair, short
05	Horns
06	Knobs
07	None
08	Peak
09	Ridge
10	Ruff
11	Spikes
12	Spines

Arm Variations

d20	Result
01-02	Additional joints
03	Bony hooks
04	Clawed paws
05	Hoofed
06	Less arms than normal
07-08	Lobster-like
09	Long claws or finger nails
10-11	Long, slender
12-13	More arms than normal (+1d6 limbs)
14	Short, stubby
15	Spider-like
16	Stiff, unbending
17	Stingers
18	Telescoping (reach is doubled)
19	Tentacles
20	Webbed fingers



Leg Variations

d20	Result
01-02	Additional joints
03	Bony hooks
04	Clawed paws
05	Fishtails instead of feet
06	Hoofed
07-08	Less legs than normal
09	Long claws or toe nails
10-11	Long, slender
12-13	More legs than normal (+1d6 limbs)
14	Short, stubby
15	Spider-like
16	Stiff, unbending
17	Stingers
18	Telescoping (can add a maximum of 1d100% to height)
19	Tentacles
20	Webbed toes

Tail Variation

d20	Result
01-02	1d6 tails
03	Fish-like
04	Horse-like
05	Lion-like
06	Long, barbed (does damage as spear)
07-08	Long, clubbed (does damage as heavy mace)
09	Long, prehensile (gives monster Improved Grab and Constriction special attacks)
10-11	Long, spaded (does damage as broadsword)
12-13	Long, spiked (does damage as war club)
14	Long, stiff (gives monster a +10 on Balance checks)
15	No tail
16	Short, canine
17	Short, feline
18	Short, reptilian
19	Stinger on end (gives monster poison attack)
20	Whip-like (does damage as whip)

Colour Variation

d20	Colouration
01-02	Black
03-04	Blue
05	Gold
06-07	Green
08-09	Roll again, radiates that colour on surrounding objects
10	Orange
11	Polychromatic
12-13	Purple
14-15	Red
16	Silver
17-18	White
19-20	Yellow

Miscellaneous Trait Variations

d20	Trait
01	Antenna
02	Elephantine ears
03	Exceptionally tall
04	Gibbering or drooling
05	Hanging fat, flaccid
06	Headless (face set in chest)
07	Horned
08	Bubbles or seethes
09	Long nose/snout
10	Radial symmetry
11	Rotting
12	Seamed
13	Second head
14	Size Category Variation
15	Small or short
16	Striped or spotted skin
17	Twitching
18	Watery, bulging eyes
19	Wrinkled
20	1d6 eyes

Body Odour Variations

d20	Trait
01	Acrid
02	Bloody
03	Chlorine
04	Citrus
05	Coffee
06	Faecal
07	Fishy
08	Gangrenous
09	Metallic
10	Mouldy
11	Putrid
12	Rotting vegetation
13	Salty
14	Smokey
15	Stale
16	Sulphurous
17	Sweaty
18	Urine
19	Vomit
20	Wet dog-smell

BESTIARY CHILD OF SET (THE GOD IN THE BOWL)

Huge Outsider (demon)

Hit Dice: 5d8+30 (52 hp)

Initiative: +8 (+2 Dex, +6 Reflex)

Speed: 30 ft. (6 squares); climb 30 ft.; swim 30 ft.

Dodge Defence: 13 (-2 size, +3 natural, +2 Dex)

Damage Resistance: 5

Base Attack/Grapple: +5/+23

Attack: Slam +13 melee (1d8+10)

Full Attack: Slam +13 melee (1d8+10)

Space/Reach: 15 ft. (3)/ 10 ft. (2)

Special Attacks: Constricting grapple

Special Qualities: Darkvision 60', improved terror of the unknown

Magic Attack Bonus: +5 (+2 natural, +3 Cha)

Saves: Fort +10, Ref +6, Will +6

Abilities: Str 30, Dex 15, Con 22, Int 16, Wis 15, Cha 17

Skills: Bluff +11, Craft (alchemy) +11, Decipher Script +11, Hide +4, Intimidate +13, Knowledge (arcana) +11, Knowledge (religion) +11, Listen +10, Move Silently +12, Sense Motive +10, Spot +10

Feats: Stealthy, Steely Gaze

Climate/Terrain: Stygia

Organisation: Solitary or Pair

Advancement: 6-11 HD (huge), 12-23 HD (gargantuan), 24+ HD (colossal); or by character class (favoured class: scholar)

The gods of old times did not die, but fell into long sleeps. Their worshippers locked them into sarcophagi so that the hand of man did not disturb their slumbers. Man-serpents, ancient gods who sleep beneath the pyramids of Stygia, are ancient abominations known as the Children of Set. Whether that nomenclature is figurative or literal depends on one's religious beliefs. They have unemotional but beautiful faces with full lips that appear to be carved from marble. Beneath that fine head, however, is the 20 to 30 foot long shimmering body of a horrible serpent, thicker than a man's arm. The serpent body is generally black with curious splotches or designs.

They make reasonably useful teachers of the occult for sorcerers to enter into *demonic pacts* with, although they generally only know 1d3+1 sorcery styles (unless they have taken levels in scholar).

Combat

It can kill by driving men mad or by crushing them with its black body.

Constricting Grapple (Ex): The man-serpent may perform this attack against any target that is immediately adjacent to it or in the same square (if it drops down from above). The man-serpent can attempt a grapple against an opponent. If successful, the target becomes coiled in the grip of the beast's sinuous body and becomes constricted. The beast will automatically deal 1d8+10 (AP 12) points of constriction damage per round until the target manages to break the grapple. During this time, it cannot dodge attacks. Unarmoured foes will possibly suffocate. Normal suffocation rules apply with one exception: since this is a violent suffocation, the grappled character can only hold his breath for 1 round per point of Constitution. After this period of time, the character must make a DC 10 Constitution check in order to continue holding his breath. The save must be repeated each round, with the DC increasing by +1 for each previous success. When the character fails one of these Constitution checks, he begins to suffocate. In the first round, he falls unconscious (0 hit points). In the following round, he drops to -1 hit points and is dying. In the third round, he suffocates.

Improved Terror of the Unknown (Su): The man-serpent is so unearthly beautiful and strange it adds its Charisma modifier to the save DC for Terror (see *Conan the Roleplaying Game*). Also, any character rolling a natural 1 on their Will save dies after a number of rounds equal to his Constitution modifier.

What they called themselves, we never knew: for none of our tribe ever learned the accursed hissing sibilances they used as speech: but we called them Children of the Night. And night-things they were indeed, for they slunk in the depths of the dark forests, and in subterranean dwellings, venturing forth into the hills only when their conquerors slept. It was at night that they did their foul deeds - the quick flight of a flint-tipped arrow to the snatching of a child that had wandered from the village.

But it was for more than this that we gave them their name: they were, in truth, People of night and darkness and the ancient horror-ridden shadows of bygone ages. For these creatures were very old, and represented an outworn age. They had once overrun and possessed this land, and they had been driven into hiding and obscurity by the dark, fierce little Picts with whom we contested now, and hated and loathed them as savagely as did we.

These Children of the Night seemed not human to us, with their deformed, dwarfish bodies, yellow skin and hideous faces. Aye - they were reptiles - vermin.

Robert E. Howard, *Children of the Night*

CHILDREN OF THE NIGHT

Barbarian 1

Small Humanoid (Little People)

Hit Dice: 1d10+1 (6 hp)

Initiative: +4 (+1 Dex, +3 Reflex)

Speed: 30 ft. (6 squares)

Dodge Defence: 13 (+1 size, +1 Dex)

Parry Defence: 11 (+1 size)

DR: 1

Base Attack/Grapple: +1/-3

Attack: Club +2 melee (1d8) or javelin +3 ranged (1d8)

Full Attack: Club +2 melee (1d8) or javelin +3 ranged (1d8)

Space/Reach: 5 ft. (1)/5 ft. (1)

Special Attacks: —

Special Qualities: Darkvision 60 ft., fearless, track, versatility (-2 penalty)

Saves: Fort +3, Ref +3, Will -1

Abilities: Str 11, Dex 13, Con 12, Int 10, Wis 9, Cha 6

Skills: Hide +5, Listen +3, Move Silently +5, Ride +4, Spot +3, Survival +3

Feats: Alertness

Environment: Underground

Organization: Gang (4-9), band (10-100 plus 100% non-combatants plus 1 3rd level sergeant per 20 adults and 1 leader of 4th-6th level), warband (10-24), or tribe (40-400 plus 100% non-combatants plus 1 3rd level sergeant per 20 adults, 1 or 2 lieutenants of 4th or 5th level, 1 leader of 6th-8th level)

Advancement: By character class

They are a stocky race with broad heads that appear large for their short and scrawny bodies. Their faces are broad and square with flat noses, thin mouths and pointed ears. Their skin is scaly, yellow and mottled like a serpent. Although some tribes wear the skins of animals, most wear the skins



The Children of the Night have feral eyes that glow in the dark.

of serpents as loincloths. Their alien language is akin to the sound of reptiles. Although some tribes use captured bows, most use primitive weapons such as knives and cudgels. They are often referred to as vermin or reptiles by upper world folk, for these Little People live in the darkness beneath the world, driven there by the Picts who conquered their lands in the forests.

Their underground system of caverns, chasms and corridors are accomplishments modern engineers would be hard pressed to duplicate. They make curious designs on the walls of their lairs and worship Cthuluid gods around mysterious black stones squatting horribly on piles of grisly skulls.

DINOSAUR

A lost world almost seems incomplete without at least one ferocious dinosaur. Dinosaurs come in many sizes and shapes. Bigger varieties have drab coloration, while smaller dinosaurs have more colourful markings. Most dinosaurs have a pebbly skin texture.

Combat

Dinosaurs take full advantage of their size and speed. The swift carnivores stalk prey, staying hidden in cover until they can get into charge range and rush to the attack. Herbivores frequently overrun and trample their opponents.

DEINONYCHUS

Large Animal

Hit Dice: 4d8+16 (34 hp)

Initiative: +8 (+2 Dex, +6 Reflex)

Speed: 60 ft. (12 squares)

Dodge Defence: 14 (-1 size, +2 Dex, +3 natural)

Damage Reduction: 2

Base Attack/Grapple: +3/+11

Attack: Talons +6 melee (2d6+4)

Full Attack: Talons +6 melee (2d6+4) and 2 foreclaws +1 melee (1d3+2) and bite +1 melee (2d4+2)

Space/Reach: 10 ft. (2)/5 ft. (1)

Special Attacks: Pounce

Special Qualities: Low-light vision, scent

Saves: Fort +8, Ref +6, Will +2

Abilities: Str 19, Dex 15, Con 19, Int 2, Wis 12, Cha 10

Skills: Hide +8, Jump +26, Listen +10, Spot +10, Survival +10

Feats: Run, Track

Environment: Warm forests

Organization: Solitary, pair or pack (3-6)

Advancement: 5-8 HD (Large)

A deinonychus is bright green along its back and flanks, with a much lighter shade of the same colour on its underside. The body has darker spots or stripes. Its tail extends straight

out behind itself, held aloft by an intricate structure of bony supports, thus allowing its weight to be carried entirely by the back legs. It weighs about 600 pounds.

Combat

A deinonychus uses a combination of speed, grasping forearms, large teeth and hind legs with ripping talons. It hunts by running at prey, leaping and ripping with its rear talons as it claws and bites. The talons count as one attack. A deinonychus has a relatively large brain for a dinosaur, and its pack hunts with cunning tactics. It often grapples with its claws and tears at prey while it is holding it down or with its bite and rips at the prey while holding it within reach with its jaws.

Pounce (Ex): If a deinonychus charges, it can make a full attack.

Skills: A deinonychus has a +8 racial bonus on Hide, Jump, Listen, Spot and Survival checks.

ELASMOSAURUS

Huge Animal

Hit Dice: 10d8+80 (125 hp)

Initiative: +11 (+2 Dex, +9 Reflex)

Speed: 20 ft. (4 squares), swim 50 ft.

Dodge Defence: 17 (-2 size, +2 Dex, +7 natural)

Damage Reduction: 3

Base Attack/Grapple: +7/+23

Attack: Bite +13 melee (2d8+12)

Full Attack: Bite +13 melee (2d8+12)

Space/Reach: 15 ft. (3)/10 ft. (2)

Special Attacks: —

Special Qualities: Low-light vision, scent

Saves: Fort +15, Ref +9, Will +4

Abilities: Str 26, Dex 14, Con 22, Int 2, Wis 13, Cha 9

Skills: Hide -4*, Listen +4, Spot +9, Swim +16

Feats: Dodge, Great Fortitude, Toughness (2)

Environment: Warm aquatic

Organization: Solitary, pair or herd (5-8)

Advancement: 11-20 HD (Huge); 21-30 HD (Gargantuan)

Though it resides primarily in the water, an elasmosaurus only breathes air. An elasmosaurus has a total length of some 30 feet, including a tail half as long as its entire body, and weighs about 5,000 pounds. Observers who see only its head or tail might easily mistake it for a massive snake.

Combat

An elasmosaurus is aggressive and attacks anything it notices. The



creature is strong, fast and highly manoeuvrable, able to turn quickly and lunge at prey. When hunting, it travels with its head out of the water, snapping down quickly to seize prey.

Skills: *An elasmosaurus has a +8 racial bonus on Hide checks in water.

TRICERATOPS

Huge Animal

Hit Dice: 16d8+176 (248 hp)

Initiative: +8 (–1 Dex, +9 Reflex)

Speed: 30 ft. (6 squares)

Dodge Defence: 19 (–2 size, –1 Dex, +12 natural)

Damage Reduction: 6

Base Attack/Grapple: +12/+30

Attack: Gore +20 melee (2d8+15)

Full Attack: Gore +20 melee (2d8+15)

Space/Reach: 15 ft. (3)/10 ft. (2)

Special Attacks: Powerful charge, trample 2d12+15

Special Qualities: Low-light vision, scent

Saves: Fort +19, Ref +9, Will +6

Abilities: Str 30, Dex 9, Con 25, Int 1, Wis 12, Cha 7

Skills: Listen +13, Spot +12

Feats: Alertness, Great Fortitude, Toughness (4)

Environment: Temperate plains

Organization: Solitary, pair or herd (5–8)

Advancement: 17–32 HD (Huge); 33–48 HD (Gargantuan)

A triceratops has a body about 25 feet long and weighs about 20,000 pounds. It has a single horn over the nose and two long horns over its eyes. It is characterised also by a bony frill protecting the neck. The dinosaur has a sharp beak. It is a herbivore with hoofed toes.

Combat

These creatures are likely to charge and skewer any creature of at least Large size that infringes on their territory. A triceratops uses its trample attack on smaller opponents.

Powerful Charge (Ex): When a triceratops charges, its gore attack deals 4d8+20 points of damage.

Trample (Ex): Reflex half DC 28. The save DC is Strength-based.

TYRANNOSAURUS

Huge Animal

Hit Dice: 18d8+144 (225 hp)

Initiative: +13 (+1 Dex, +12 Reflex)

Speed: 40 ft. (8 squares)

Dodge Defence: 22 (-2 size, +1 Dex, +13 natural)

Damage Reduction: 4

Base Attack/Grapple: +13/+30

Attack: Bite +20 melee (3d6+13, AP 12)

Full Attack: Bite +20 melee (3d6+13, AP 12)

Space/Reach: 15 ft. (3)/10 ft. (2)

Special Attacks: Improved grab

Special Qualities: Low-light vision, scent

Saves: Fort +16, Ref +12, Will +8

Abilities: Str 28, Dex 12, Con 21, Int 2, Wis 15, Cha 10

Skills: Hide -2, Listen +14, Spot +14

Feats: Alertness, Improved Natural Attack (bite), Run, Toughness (3), Track

Environment: Warm plains

Organization: Solitary or pair

Advancement: 19–36 HD (Huge); 37–54 HD (Gargantuan)

Despite its enormous size and 6-ton weight, a tyrannosaurus is a swift runner. Its head is nearly 6 feet long, and its teeth are from 3 to 6 inches in length. It is slightly more than 30 feet long from nose to tail. It has massive serrated teeth and can bite through bone and armour.

Combat

A tyrannosaurus pursues and eats just about anything it sees. Its tactics are simple – charge in and bite. It can grapple with its feet to hold down prey while it rips with its bite.

Improved Grab (Ex): To use this ability, a tyrannosaurus must hit an opponent of up to one size smaller with its bite attack. It can then attempt to start a grapple as a free action without provoking an attack of opportunity. If it wins the grapple check, it establishes a hold and can try to swallow the foe the following round.

Skills: A tyrannosaurus has a +2 racial bonus on Listen and Spot checks.

FOAMING BLASPHEMY

Medium Outsider (demon)

Hit Dice: 8d8+8 (44 hp)

Initiative: +12 (+1 Dex, +7 Reflex, +4 Improved Initiative)

Speed: 20 ft. (4 squares)

Dodge Defence: 17 (+1 Dex, +6 natural)

Damage Reduction: 5

Base Attack/Grapple: +8/+10

Attack: Claw +10 melee (1d3+2 plus corporeal instability)

Full Attack: 2 claws +10 melee (1d3+2 plus corporeal instability)

Space/Reach: 5 ft. (1)/5 ft. (1)

Special Attacks: Corporeal instability, terror (DC 14)

Special Qualities: Darkvision 60 ft., immunity to critical hits and transformation, mad thing drumming

Saves: Fort +7, Ref +7, Will +6

Abilities: Str 14, Dex 13, Con 13, Int 10, Wis 10, Cha 10

Skills: Climb +13, Escape Artist +12, Hide +12, Jump +9, Listen +11, Perform (percussion) +14, Spot +11, Survival +0 (+2 following tracks), Tumble +14, Use Rope +1 (+3 with bindings)

Feats: Improved Initiative, Mobility, Skill Focus (Perform (percussion))

Advancement: 9–12 HD (Medium); 13–24 HD (Large)

The horrific creatures known as foaming blasphemies have mutable, ever-changing forms. A foaming blasphemy's dimensions vary, but it always weighs about 200 pounds. Foaming blasphemies do not speak.

Combat

Despite its fearsome appearance, whether it has claws, fangs, pincers, tentacles, or spines, a foaming blasphemy does little physical harm. Regardless of form, the creature seems unable to manage more than two attacks per round. Its continual transmutations prevent the coordination needed to do more.

Mad Thing Drumming (Su): With a successful Perform (percussion) check (DC 23), the foaming blasphemy may grant one scholar within range a +1 morale bonus to his magic attack rolls plus an additional +1 for every 5 points that the foaming blasphemy exceeds

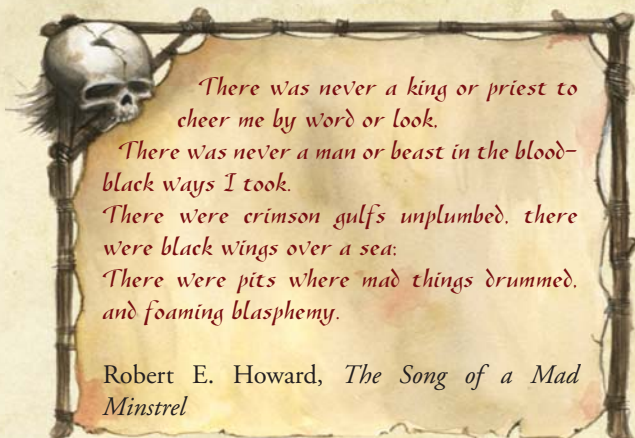

a DC 23 on its Perform check. The foaming blasphemy must have a Magical Link to the target scholar if it does not have line of sight to him.

Corporeal Instability (Su): A blow from a foaming blasphemy against a living creature can cause a terrible transformation. The creature must succeed on a Fortitude save (DC 15) or become a spongy, amorphous mass. Unless the victim manages to control the effect (see below), its shape melts, flows, writhes and boils. The save DC is Constitution-based.

An affected creature is unable to hold or use any item. Clothing, armour, rings and helmets become useless. Large items worn or carried – armour, backpacks, even shirts – hamper more than help, reducing the victim's Dexterity score by 4. Soft or misshapen feet and legs reduce speed to 10 feet or one-quarter normal, whichever is less. Searing pain courses along the nerves, so strong that the victim cannot act coherently. The victim cannot cast spells or use magic items, and it attacks blindly, unable to distinguish friend from foe (–4 penalty on attack rolls and a 50% miss chance, regardless of the attack roll).

Each round the victim spends in an amorphous state causes 1 point of Wisdom drain from mental shock. If the victim's Wisdom score falls to 0, it becomes a foaming blasphemy.

A victim can regain its own shape by taking a standard action to attempt a Will save (DC 15) (this check DC does not vary for a foaming blasphemy with different Hit Dice or ability scores). A success re-establishes the creature's normal form. On a failure, the victim can still repeat this check each round until successful. Corporeal instability is not a disease or a curse and so is hard to remove. A *warding* or *greater warding* spell removes the affliction.

Immunity to Transformation (Ex): No mortal magic can permanently affect or fix a foaming blasphemy's form. Effects such as *awful rite of the were-beast* force the creature into a new shape, but at the start of its next turn it immediately returns to its mutable form as a free action.

LIZARD, MONITOR

Medium Animal

Hit Dice: 3d8+9 (22 hp)

Initiative: +7 (+2 Dex, +5 Reflex)

Speed: 30 ft. (6 squares), swim 30 ft.

Defence Value: 13 (+2 Dex, +1 natural)

Damage Reduction: 2

Base Attack/Grapple: +2/+5

Attack: Bite +5 melee (1d8+4)

Full Attack: Bite +5 melee (1d8+4)

Space/Reach: 5 ft. (1)/5 ft. (1)

Special Attacks: —

Special Qualities: Low-light vision

Saves: Fort +6, Ref +5, Will +2

Abilities: Str 17, Dex 15, Con 17, Int 2, Wis 12, Cha 2

Skills: Climb +7, Hide +6*, Listen +4, Move Silently +6, Spot +4, Swim +11

Feats: Alertness, Run

Environment: Warm forests

Organization: Solitary

Advancement: 4-5 HD (Medium); 6-9 HD (Large)

This category includes fairly large, carnivorous lizards averaging from 3 to 5 feet long. The Styx monitor lizard reaches 7 feet in length; the Kambujan monitor lizard commonly reaches over 10 feet in length, weighs 365 lbs. and will eat livestock and humans. They are all active predators and scavengers, controlling populations of prey and providing food for larger carnivores, such as crocodiles and birds of prey. Their prey is usually insects, crabs, snakes, eggs, small crocodiles, carrion, fish, eels and even humans. Monitor lizards can run faster than most humans and can climb well. They can hold their breath for up to half an hour and have even been seen swimming out to sea.

The large monitor lizards of the Hyborian Age have a streamlined shape, elongated neck and forked tongue. The Styx monitor has tall neural spines on its vertebrae so it can be used for propulsion. They are harvested as a source of protein and income in the Black Kingdoms. They breed quickly, so the harvesting is quite sustainable. The meat of a monitor is a delicacy and many potions, ointments, poisons and alchemical items can be created from various parts of their bodies. In Khitai and Kambuja, monitors are protected because they eat the crabs that might otherwise destroy the banks of rice fields.

Combat

Monitor lizards can be aggressive, using their powerful jaws to tear at prey or enemies. When attacked, monitor lizards try to intimidate prey by lashing with their tails, inflating their throats, hissing loudly and making aggressive movements. Their hunting technique is to run after prey instead of stalking and ambushing. They can eat prey almost as big as themselves. The Kambujan monitor, for example, can swallow half a boar in one gulp, hooves and all.

Skills: A monitor lizard has a +8 racial bonus on any Swim check to perform some special action or avoid a hazard. It can always choose to take 10 on a Swim check, even if distracted or endangered. It can use the run action while swimming, provided it swims in a straight line. Monitor lizards have a +4 racial bonus on Hide and Move Silently checks. *In forested or overgrown areas, the Hide bonus improves to +8.

	Scorpion, Tiny	Scorpion, Small	Scorpion, Medium
	Tiny Vermin	Small Vermin	Medium Vermin
Hit Dice:	½d8+2 (4 hp)	1d8+2 (6 hp)	2d8+4 (13 hp)
Initiative:	+0	+0	+0
Speed:	20 ft. (4 squares)	30 ft. (6 squares)	40 ft. (8 squares)
Dodge Defence:	12 (+2 size)	11 (+1 size)	10 (+0 natural)
DR:	—	3 (exoskeleton)	4 (exoskeleton)
Base Attack/Grapple:	+0/-12	+0/-5	+1/+2
Attack:	Claw +2 melee finesse (1d2-4)	Claw +1 melee finesse (1d3-1)	Claw +2 melee (1d4+1)
Full Attack:	2 claws +2 melee finesse (1d2-4) and sting -3 melee finesse (1d2-4 plus poison)	2 claws +1 melee finesse (1d3-1) and sting -4 melee finesse (1d3-1 plus poison)	2 claws +2 melee (1d4+1) and sting -3 melee (1d4 plus poison)
Space/Reach:	2½ ft. (½)/0 ft. (0)	5 ft. (1)/5 ft. (1)	5 ft. (1)/5 ft. (1)
Special Attacks:	Constrict 1d2-4, improved grab, poison	Constrict 1d3-1, improved grab, poison	Constrict 1d4+1, improved grab, poison
Special Qualities:	Darkvision 60 ft., tremorsense 60 ft., vermin traits	Darkvision 60 ft., tremorsense 60 ft., vermin traits	Darkvision 60 ft., tremorsense 60 ft., vermin traits
Saves:	Fort +4, Ref +0, Will +0	Fort +4, Ref +0, Will +0	Fort +5, Ref +0, Will +0
Abilities:	Str 3, Dex 10, Con 14, Int —, Wis 10, Cha 2	Str 9, Dex 10, Con 14, Int —, Wis 10, Cha 2	Str 13, Dex 10, Con 14, Int —, Wis 10, Cha 2
Skills:	Climb +0, Hide +12, Spot +4	Climb +3, Hide +8, Spot +4	Climb +5, Hide +4, Spot +4
Feats:	—	—	—
Environment:	Any but arctic	Any but arctic	Warm deserts/jungles
Organization:	Colony (8-16)	Colony (2-5) or swarm (6-11)	Solitary or colony (2-5)
Advancement:	—	—	3-4 HD (Medium)

	Scorpion, Large	Scorpion, Huge
	Large Vermin	Huge Vermin
Hit Dice:	5d8+10 (32 hp)	10d8+30 (75 hp)
Initiative:	+1 (+1 Reflex)	+3 (+3 Reflex)
Speed:	50 ft. (10 squares)	50 ft. (10 squares)
Dodge Defence:	10 (-1 size, +1 natural)	11 (-2 size, +3 natural)
DR:	7 (exoskeleton)	12 (exoskeleton)
Base Attack/Grapple:	+3/+11	+7/+21
Attack:	Claw +6 melee (1d6+4)	Claw +11 melee (1d8+6)
Full Attack:	2 claws +6 melee (1d6+4) and sting +1 melee (1d6+2 plus poison)	2 claws +11 melee (1d8+6) and sting +6 melee (2d4+3 plus poison)
Space/Reach:	10 ft. (2)/5 ft. (1)	15 ft. (3)/10 ft. (2)
Special Attacks:	Constrict 1d6+4, improved grab, poison	Constrict 1d8+6, improved grab, poison
Special Qualities:	Darkvision 60 ft., tremorsense 60 ft., vermin traits	Darkvision 60 ft., tremorsense 60 ft., vermin traits
Saves:	Fort +6, Ref +1, Will +1	Fort +10, Ref +3, Will +3
Abilities:	Str 19, Dex 10, Con 14, Int —, Wis 10, Cha 2	Str 23, Dex 10, Con 16, Int —, Wis 10, Cha 2
Skills:	Climb +8, Hide +0, Spot +4	Climb +10, Hide -4, Spot +4
Feats:	—	—
Environment:	Warm deserts	Warm deserts
Organization:	Solitary or colony (2-5)	Solitary or colony (2-5)
Advancement:	6-9 HD (Large)	11-19 HD (Huge)

Scorpion, Gargantuan**Gargantuan Vermin**

Hit Dice:	20d8+60 (150 hp)
Initiative:	+6 (+6 Reflex)
Speed:	50 ft. (10 squares)
Dodge Defence:	13 (-4 size, +7 natural)
DR:	18 (exoskeleton)
Base Attack/Grapple:	+15/+37
Attack:	Claw +21 melee (2d6+10)
Full Attack:	2 claws +21 melee (2d6+10) and sting +16 melee (2d6+5 plus poison)
Space/Reach:	20 ft. (4)/15 ft. (3)
Special Attacks:	Constrict 2d6+10, improved grab, poison
Special Qualities:	Darkvision 60 ft., tremorsense 60 ft., vermin traits
Saves:	Fort +15, Ref +6, Will +6
Abilities:	Str 31, Dex 10, Con 16, Int —, Wis 10, Cha 2
Skills:	Climb +14, Hide -8, Spot +4
Feats:	—
Environment:	Warm deserts
Organization:	Solitary
Advancement:	21–39 HD (Gargantuan)

Scorpion, Colossal**Colossal Vermin**

Hit Dice:	40d8+120 (300 hp)
Initiative:	+11 (-1 Dex, +12 Reflex)
Speed:	50 ft. (10 squares)
Dodge Defence:	15 (-8 size, -1 Dex, +14 natural)
DR:	25 (exoskeleton)
Base Attack/Grapple:	+30/+58
Attack:	Claw +34 melee (2d8+12)
Full Attack:	2 claws +34 melee (2d8+12) and sting +29 melee (2d8+6 plus poison)
Space/Reach:	40 ft. (8)/30 ft. (6)
Special Attacks:	Constrict 2d8+12, improved grab, poison
Special Qualities:	Darkvision 60 ft., tremorsense 60 ft., vermin traits
Saves:	Fort +25, Ref +12, Will +13
Abilities:	Str 35, Dex 8, Con 16, Int —, Wis 10, Cha 2
Skills:	Climb +16, Hide -12, Spot +4
Feats:	—
Environment:	Warm deserts
Organization:	Solitary
Advancement:	41–60 HD (Colossal)

SCORPION

Scorpions are relatives of spiders and other arachnids. They are found throughout Shem, even in the meadows. They have pedipalps with pincer claws, three pairs of legs, an elongated body and a segmented, venomous stinger. They have two median eyes and two to five pairs of lateral eyes at the corners of their 'heads'. The pedipalps are covered with sensory hairs that detect vibrations in the air and its legs have small organs that detect tremors in the ground. On its underside, the scorpion has a unique pair of sense organs that sense textures of surfaces.

Most scorpions are quite tiny and the largest scorpions that occur naturally in the Hyborian Age barely reach three feet in length. Sorcerers, however, have bred and modified scorpions through the centuries to hideously huge sizes.

Scorpion venom is usually not lethal in most varieties. Usually if a scorpion has large pincers, its venom will not hurt a human. The smaller the scorpion's relative pincer size, the more lethal its venom is. Scorpions are carnivores, eating insects and rodents.

Combat

Scorpions are likely to attack any creature that approaches and they usually charge when attacking prey.

Constrict (Ex): A scorpion deals automatic claw damage on a successful grapple check.

Improved Grab (Ex): To use this ability, a scorpion must hit with a claw attack. A scorpion can use either its Strength modifier or Dexterity modifier for grapple checks, whichever is better.

Tremorsense (Ex): A scorpion is sensitive to vibrations in the ground and can automatically pinpoint the location of anything that is in contact with the ground.

Poison (Ex): In lethal varieties of scorpions, its neurotoxin produces great pain and swelling in its victims. Numbness covers the body, followed by frothing at the mouth and difficulties in breathing. Eventually the victim's muscles start twitching and the victim starts convulsing. If the victim dies, it is from respiratory failure or heart failure some hours later. The details vary by the scorpion's size, as follows. The save DCs are Constitution-based. The indicated damage is initial and secondary damage.

Size	Fort DC	Damage
Tiny	14	1 Con
Small	13	1d2 Con
Medium	12	1d3 Con
Large	13	1d4 Con
Huge	18	1d6 Con
Gargantuan	23	1d8 Con
Colossal	33	1d10 Con

Skills: A monstrous scorpion has a +4 racial bonus on Climb, Hide and Spot checks.

SNAKE THAT SPEAKS (SNAKE-MAN OF THE ELDER PLANET; SERPENT-MAN)

Medium Aberration

Hit Dice: 4d8–4 (14 hp)

Initiative: +1 (+1 Reflex)

Speed: 30 ft. (6 squares)

Dodge Defence: 12 (+1 natural, +1 dodge)

DR: –

Base Attack/Grapple: +3/+4

Attack: Bite +4 melee (1d4 plus poison) or by weapon

Full Attack: Bite +4 melee (1d4 plus poison) or by weapon

Space/Reach: 5 ft. (1)/ 5 ft. (1)

Special Attacks: Poison

Special Qualities: Aberration traits (except immunity to physical attack forms), darkvision 60 ft., scent, shape-shifting, soul-enslavement

Magic Attack Bonus: +3 (+1 natural, +2 Cha)

Saves: Fort +0, Ref +1, Will +7

Abilities: Str 12, Dex 10, Con 8, Int 16, Wis 17, Cha 15

Skills: Bluff +7, Craft (alchemy) +5, Knowledge (arcana) +10, Listen +10, Sense Motive +10, Spot +10

Feats: Alertness, Dodge

Climate/Terrain: Any

Organisation: Solitary or Pair (except in Yanyoga, which is an entire city of serpent-folk)

Advancement: By character class (favoured class: scholar)

The snake-men are deceivers of man, the former rulers of the world. They look like a man with mottled, scaled skin and the head of a monstrous serpent. Their eyesight is particularly sharp and especially attuned to detect motion. Pits along the snake-man's snout allow the creature to detect



heat, giving it the ability to 'see' in complete darkness. They identify each other through scent and, when not disguised, give off an ophidian odour. They smell through their forked tongues. Between their keen eyes, heat-sensing pits and odour-detecting tongues, the serpent men have a natural +6 to their Spot skills. Their hearing is also extremely acute. They lack external ears but they sense vibrations through a combination of inner ears and through their jaws and other bones. Vibrations along the ground transfer up through the body to the inner ear. A snake-that-speaks always hears a person coming before seeing that person. Snake-men have a natural +8 bonus to Listen because of this. These incredible senses also help them to determine a person's mood and intent, giving them a +6 racial bonus to Sense Motive.

The origin of the Snakes-That-Speak is shrouded in mystery. Some claim they were spawned by Yig and others claim they are the spawn of Set, the Old Serpent. Perhaps the two gods are one and the same, just with differing cultural names. An odd mixture of mammal and reptile, they surely are not a naturally

For as he watched, Tu's face became strangely dim and unreal: the features mingled and merged in a seemingly impossible manner. Then, like a fading mask of fog, the face suddenly vanished and in its stead gaped and leered a monstrous serpent's head!

The Shadow Kingdom, Robert E. Howard.

evolved life form, but an abomination created by Set (or Yig) when he walked the Earth in physical form. Some Nemedian scholars believe they were formed by joining a Serpent of Set with a man-ape. The scholars also believe the serpent-men are immortal. There are rumours of living snake-men who have seen millennia pass.

At one time they were the rulers of the Thurian continent and their capital was in Valusia. The men of the age were the slaves of the serpent-folk. After many millennia, perhaps even a million years, this empire was destroyed and Valusia came to be ruled by humans. The serpent-folk went into hiding. Using their powers of disguise, they would replace humans of power and rule in their stead, and so they continued to rule the humans. For millennia this was a successful ruse – one which ended with an Atlantean usurper named Kull, who hunted the species to near extinction. Now, millennia later, the last remnants of their civilisation lies in the city of Yanyoga beyond the Fires of the South. However, hibernating individuals may still lurk in the shadowed hills of the forgotten places of the Earth. Although they were once great scientists, known for alchemy and genetic planning, the remaining serpent-folk have fallen into bestiality and the practise of sorcery once more. Serpent-men who have survived alone without the benefit of a society (such as Yanyoga) mate with snakes, a practise that is weakening the race as a whole.

They are mortal enemies of flying dragons and they will never willingly wear any symbol portraying such a thing. Unlike most aberrations, the snake-that-speaks does not have any immunity to physical attack forms.

A common tactic for individual surviving serpent-men is to pose as a high priest of some darksome god, who is usually none other than Old Set under an assumed name. They are often surrounded by the ghosts of those slain by the serpent folk, for they enslave the souls of those they kill.

Combat

Snakes That Speak usually attack with melee weapons, with their bite or with alchemical weapons.

Poison (Ex): Serpent-man venom blocks nerve impulses, causing respiratory failure and death. Symptoms include drowsiness, nausea, vomiting and abdominal pain. In addition, the effects of the bite include darkening and blistering of the flesh around the fang punctures and rotting flesh within 48 hours of the bite. The wound typically smells quite putrid within minutes of the bite or injection of the venom by a poisoned weapon.

This poison must be delivered through a wound.

If a creature has sufficient damage reduction to avoid taking any damage from the attack, the poison does not affect

it. Characters who take damage from a serpent-man's bite must make a Fort save (DC 14 + serpent-man's Con bonus) or take 2d4 Strength damage in 10 minutes, with secondary damage of 1d4 Strength a minute later.

Shape-Shifting (Su): These fiends can take any human form they wish by flinging a web of sorcery about their faces, as an actor dons a mask, so that they resemble anyone they wish to. They gain a +10 competence bonus to Disguise checks. If a serpent-man is killed, he automatically reverts to normal form. If a serpent-man hears the *words that unweave*, they also revert to normal form. Reflective surfaces also reveal their true form, for the sorcery that clouds the minds of men does not fool a mirror, which has no mind to cloud.

Soul Enslavement (Su): If a man is slain by a snake-man his ghost becomes their slave, to do their bidding throughout eternity.

Favoured Class: The favoured class for a snake-man is scholar. Hypnotism and Necromancy are their preferred sorcery styles.

SWARM

Swarms are dense masses of animals that would not be particularly dangerous in small groups, but can be terrible foes when gathered in sufficient numbers. For game purposes a swarm is defined as a single creature with a space of 10 feet – gigantic hordes are actually composed of dozens of swarms in close proximity. A swarm has a single pool of Hit Dice and hit points, a single initiative modifier, a single speed and a single Dodge Defence. It makes saving throws as a single creature.

Many different creatures can mass as swarms; bat swarms, centipede swarms, rat swarms, scorpion swarms, spider swarms and viper swarms are described here. The swarm's type varies with the nature of the component creature (most are animals or vermin), but all swarms have the swarm subtype.

A swarm of Medium creatures consists of 12 nonflying creatures or 40 flying creatures. A swarm of small creatures consists of 60 nonflying creatures or 200 flying creatures. A swarm of Tiny creatures consists of 300 nonflying creatures or 1,000 flying creatures. A swarm of Diminutive creatures consists of 1,500 nonflying creatures or 5,000 flying creatures. A swarm of Fine creatures consists of 10,000 creatures, whether they are flying or not. Swarms of nonflying creatures include many more creatures than could normally fit in a 10-foot square based on their normal space, because creatures in a swarm are packed tightly together and generally crawl over each other and their prey when moving or attacking. Larger swarms are represented by multiples of single swarms. A large swarm is completely shapeable, though it usually remains contiguous.

Combat

In order to attack, a single swarm moves into an opponents' space, which provokes an attack of opportunity. It can occupy the same space as a creature of any size, since it crawls all over its prey, but remains a creature with a 10-foot space. Swarms never make attacks of opportunity, but they can provoke attacks of opportunity.

Unlike other creatures with a 10-foot space, a swarm is shapeable. It can occupy any four contiguous squares, and it can squeeze through any space large enough to contain one of its component creatures.

Vulnerabilities of Swarms

Swarms are extremely difficult to fight with physical attacks. However, they have a few special vulnerabilities, as follows: A lit torch swung as an improvised weapon deals 1d3 points of fire damage per hit.

A lit lantern can be used as a thrown weapon, dealing 1d4 points of fire damage to all creatures in squares adjacent to where it breaks.

BAT SWARM

Diminutive Animal (Swarm)

Hit Dice: 3d8 (13 hp)

Initiative: +9 (+2 Dex, +7 Reflex)

Speed: 5 ft. (1 square), fly 40 ft. (good)

Dodge Defence: 17 (+4 size, +2 Dex, +1 natural)

Base Attack/Grapple: +2/—

Attack: Swarm (1d6)

Full Attack: Swarm (1d6)

Space/Reach: 10 ft. (2)/0 ft. (0)

Special Attacks: Distraction, wounding

Special Qualities: Blindsight 20 ft., half damage from slashing and piercing, low-light vision, swarm traits

Saves: Fort +3, Ref +7, Will +3

Abilities: Str 3, Dex 15, Con 10, Int 2, Wis 14, Cha 4

Skills: Listen +11, Spot +11

Feats: Alertness, Lightning Reflexes

Environment: Temperate deserts



Organization: Solitary, flight (2–4 swarms), or colony (11–20 swarms)

Advancement: None

A bat swarm is nocturnal, and is never found above ground in daylight.

Combat

A bat swarm seeks to surround and attack any warm-blooded prey it encounters. The swarm deals 1d6 points of damage to any creature whose space it occupies at the end of its move.

Distraction (Ex): Any living creature that begins its turn with a swarm in its space must succeed on a Fortitude save (DC 11) or be nauseated for 1 round. The save DC is Constitution-based.

Wounding (Ex): Any living creature damaged by a bat swarm continues to bleed, losing 1 hit point per round thereafter. Multiple wounds do not result in cumulative bleeding loss. The bleeding can be stopped by a Heal check (DC 10).

Blindsense (Ex): A bat swarm notices and locates creatures within 20 feet. Opponents still have total concealment against the bat swarm (but swarm attacks ignore concealment).

Skills: A bat swarm has a +4 racial bonus on Listen and Spot checks. These bonuses are lost if its blindsense is negated.

CENTIPEDE SWARM

Diminutive Vermin (Swarm)

Hit Dice: 9d8–9 (31 hp)

Initiative: +11 (+4 Dex, +7 Reflex)

Speed: 20 ft. (4 squares), climb 20 ft.

Dodge Defence: 24 (+4 size, +4 Dex, +6 natural)

Damage Reduction: —

Base Attack/Grapple: +6/—

Attack: Swarm (2d6 plus poison)

Full Attack: Swarm (2d6 plus poison)

Space/Reach: 10 ft. (2)/0 ft. (0)

Special Attacks: Distraction, poison

Special Qualities: Darkvision 60 ft., immune to weapon damage, swarm traits, tremorsense 30 ft., vermin traits

Saves: Fort +5, Ref +7, Will +3

Abilities: Str 1, Dex 19, Con 8, Int —, Wis 10, Cha 2

Skills: Climb +12, Spot +4

Feats: —

Environment: Underground

Organization: Solitary, tangle (2–4 swarms), or colony (7–12 swarms)

Advancement: —

Combat

A centipede swarm seeks to surround and attack any living prey it encounters. A swarm deals 2d6 points of damage to any creature whose space it occupies at the end of its move.

Distraction (Ex): Any living creature that begins its turn with a centipede swarm in its space must succeed on a Fortitude save (DC 13) or be nauseated for 1 round. The save DC is Constitution-based.

Poison (Ex): Injury, Fortitude DC 13, initial and secondary damage 1d4 Dex. The save DC is Constitution-based.

Skills: A centipede swarm has a +4 racial bonus on Spot checks and a +8 racial bonus on Climb checks, and uses its Dexterity modifier instead of its Strength modifier for Climb checks. A centipede swarm has a +8 racial bonus on Climb checks and can always choose to take 10 on a Climb check, even if rushed or threatened.

RAT SWARM

Tiny Animal (Swarm)

Hit Dice: 4d8 (18 hp)

Initiative: +8 (+2 Dex, +6 Reflex)

Speed: 15 ft. (3 squares), climb 15 ft.

Dodge Defence: 17 (+2 size, +2 Dex, +3 natural)

Base Attack/Grapple: +3/—

Attack: Swarm (1d6 plus disease)

Full Attack: Swarm (1d6 plus disease)

Space/Reach: 10 ft. (2)/0 ft. (0)

Special Attacks: Disease, distraction

Special Qualities: Half damage from slashing and piercing, low-light vision, scent, swarm traits

Saves: Fort +4, Ref +6, Will +2

Abilities: Str 2, Dex 15, Con 10, Int 2, Wis 12, Cha 2

Skills: Balance +10, Climb +10, Hide +14, Listen +6, Spot +7, Swim +10

Feats: Alertness

Environment: Any

Organization: Solitary, pack (2–4 swarms) or infestation (7–12 swarms)

Advancement: None

Combat

A rat swarm seeks to surround and attack any warm-blooded prey it encounters. A swarm deals 1d6 points of damage to any creature whose space it occupies at the end of its move.

Disease (Ex): Filth fever – swarm attack, Fortitude DC 12, incubation period 1d3 days, damage 1d3 Dex and 1d3 Con. The save DC is Constitution-based.

Distraction (Ex): Any living creature that begins its turn with a swarm in its square must succeed on a Fortitude save (DC 12) or be nauseated for 1 round. The save DC is Constitution-based.

Skills: A rat swarm has a +4 racial bonus on Hide and Move Silently checks, and a +8 racial bonus on Balance, Climb and Swim checks. A rat swarm can always choose to take 10 on all Climb checks, even if rushed or threatened. A rat swarm uses its Dexterity modifier instead of its Strength modifier for Climb and Swim checks. A rat swarm has a +8 racial bonus on any Swim check to perform some special action or avoid a hazard. It can always choose to take 10 on a Swim check, even if distracted or endangered. It can use the run action while swimming, provided it swims in a straight line.

SCORPION SWARM

Tiny Vermin (Swarm)

Hit Dice: 4d8+8 (26 hp)

Initiative: +1 (+1 Reflex)

Speed: 20 ft. (4 squares)

Dodge Defence: 12 (+2 size)

DR: —

Base Attack/Grapple: +0/–

Attack: Swarm (1d6 plus poison)

Full Attack: Swarm (1d6 plus poison)

Space/Reach: 10 ft. (2)/0 ft. (0)

Special Attacks: Distraction, poison

Special Qualities: Darkvision 60 ft., swarm traits, tremorsense 60 ft., vermin traits

Saves: Fort +6, Ref +1, Will +1

Abilities: Str 3, Dex 10, Con 14, Int —, Wis 10, Cha 2

Skills: Climb +0, Hide +12, Spot +4

Feats: —

Environment: Any but arctic

Organization: Solitary, tangle (2–4 swarms) or colony (7–12 swarms)

Combat

A scorpion swarm seeks to surround and attack any living prey it encounters. A swarm deals 1d6 points of damage to any creature whose space it occupies at the end of its move.

Distraction (Ex): Any living creature that begins its turn with a scorpion swarm in its space must succeed on a DC 11 Fortitude save or be nauseated for 1 round. The save DC is Constitution-based.

Poison (Ex): In lethal varieties of scorpions, its neurotoxin produces great pain and swelling in its victims. Numbness covers the body, followed by frothing at the mouth and

difficulties in breathing. Eventually the victim's muscles start twitching and the victim starts convulsing. If the victim dies, it is from respiratory failure or heart failure some hours later. Injury, Fortitude DC 14, initial and secondary damage 1 Con. The save DC is Constitution-based.

Skills: A scorpion swarm has a +4 racial bonus on Climb, Hide, and Spot checks.

SPIDER SWARM

Diminutive Vermin (Swarm)

Hit Dice: 2d8 (9 hp)

Initiative: +6 (+3 Dex, +3 Reflex)

Speed: 20 ft. (4 squares), climb 20 ft.

Dodge Defence: 17 (+4 size, +3 Dex)

Base Attack/Grapple: +1/–

Attack: Swarm (1d6 plus poison)

Full Attack: Swarm (1d6 plus poison)

Space/Reach: 10 ft. (2)/0 ft. (0)

Special Attacks: Distraction, poison

Special Qualities: Darkvision 60 ft., swarm traits, tremorsense 30 ft., vermin traits

Saves: Fort +3, Ref +3, Will +0

Abilities: Str 1, Dex 17, Con 10, Int —, Wis 10, Cha 2

Skills: Climb +11, Spot +4

Feats: —

Environment: Warm forests

Organization: Solitary, tangle (2–4 swarms) or colony (7–12 swarms)

Advancement: None

Combat

A spider swarm seeks to surround and attack any living prey it encounters. A swarm deals 1d6 points of damage to any creature whose space it occupies at the end of its move.

Distraction (Ex): Any living creature that begins its turn with a spider swarm in its space must succeed on a Fortitude save (DC 11) or be nauseated for 1 round. The save DC is Constitution-based.

Poison (Ex): Injury, Fortitude DC 11, initial and secondary damage 1d3 Str. The save DC is Constitution-based.

Skills: A spider swarm has a +4 racial bonus on Hide and Spot checks and a +8 racial bonus on Climb checks. It uses its Dexterity modifier instead of its Strength modifier for Climb checks. It can always choose to take 10 on a Climb check, even if rushed or threatened.

VIPER SWARM

A swarm of vipers is a mass of writhing, crawling snakes. They can drop out of trees or form a nauseating carpet of looping and wriggling life.

Combat

Poison (Ex): Bite, Fortitude save (DC 11 for all sizes); initial and secondary damage 1d6 temporary Constitution.

Distraction (Ex): Any living creature that begins its turn with a swarm in its square must succeed on a Fortitude save (DC 12) or be nauseated for 1 round. The save DC is Constitution-based.

Skills: Vipers receive a +4 racial bonus to Hide, Listen, and Spot checks and a +8 racial bonus to Balance checks. They can use either their Strength or Dexterity modifier for Climb checks, whichever is better.

	Viper Swarm, Tiny Snakes Tiny Animal (Swarm)	Viper Swarm, Small Snakes Small Animal (Swarm)	Viper Swarm, Medium Snakes Medium Animal (Swarm)
Hit Dice:	4d8 (18 hp)	16d8 (72 hp)	32d8 (144 hp)
Initiative:	+10 (+3 Dex, +7 Reflex)	+16 (+3 Dex, +13 Reflex)	+24 (+3 Dex, +21 Reflex)
Speed:	15 ft. (6 squares), climb 15 ft., swim 15 ft.	20 ft. (4 squares), climb 20 ft., swim 20 ft.	20 ft. (4 squares), climb 20 ft., swim 20 ft.
Dodge Defence:	18 (+2 size, +3 Dex, +3 natural)	26 (+1 size, +3 Dex, +12 natural)	36 (-1 size, +3 Dex, +24 natural)
Damage Reduction:	1	2	3
Base Attack/Grapple:	+3/-	+12/-	+24/-
Attacks:	Swarm (1d6 plus poison)	Swarm (4d6 and poison)	Swarm (5d6 and poison)
Full Attack:	Swarm (1d6 plus poison)	Swarm (4d6 and poison)	Swarm (5d6 and poison)
Space/Reach:	10 ft. (2)/0 ft. (0)	10 ft. (2)/0 ft. (0)	10 ft. (2)/0 ft. (0)
Special Attacks:	Distraction, poison	Distraction, poison	Distraction, poison
Special Qualities:	Scent, swarm traits	Scent, swarm traits	Scent, swarm traits
Saves:	Fort +4, Ref +7, Will +2	Fort +10, Ref +13, Will +6	Fort +18, Ref +21, Will +11
Abilities:	Str 6, Dex 17, Con 11, Int 1, Wis 12, Cha 2	Str 6, Dex 17, Con 11, Int 1, Wis 12, Cha 2	Str 8, Dex 17, Con 11, Int 1, Wis 12, Cha 2
Skills:	Balance +11, Climb +12, Hide +18, Listen +8, Spot +8	Balance +11, Climb +12, Hide +15, Listen +9, Spot +9	Balance +11, Climb +12, Hide +12, Listen +9, Spot +9
Climate/Terrain:	Temperate and warm land, aquatic and underground	Temperate and warm land, aquatic and underground	Temperate and warm land, aquatic and underground
Organization:	Solitary	Solitary	Solitary
Advancement:	—	—	—

Index

A

Ababenzar 40
Adventure Hooks 127
Agent of Cataclysmic Change 12
Alhmet 43
Alien Nature of the Ruins 23
Alkmeenon 34
Amanar's Keep 46
Ancient Events & Periods 6
Ankh of Selkhet 85
Aquilonia 26
Argos 27
Artefacts 17
Ax of Varanghi 95

B

Bat Swarm 151
Bêcharadur 40
Black Lotus 51
Black Ones 79
Border Kingdom 29
Brythunia 29
Burning Skull of Xuchotl 113
Buryat 40

C

Calm of the Dead 136
Castle of Valbroso 48
Cataclysmic Change 8
Catacombs 110
Cave-Ins or Collapses 128
Centipede Swarm 152
Children of the Night 142
Child of Set 141

Cimmeria 29
City of the Ghouls 48, 55
City of the Winged One 35, 49
Conan the Free Companion 118
Corinthia 29
Crawler of Xuchotl 114

D

Dagoth Hill 46, 64
Dead of Pteion 95
Deinonychus 143
Demon-God of the Ghouls 61
Dragon 116

E

Eidoran 28
El-Shah-Maddoc 34
Elasmosaurus 143
Exploring Ruins 126

F

Feats of the Tomb-Raiders 136
Foaming Blasphemy 145
Forbidden City, The 31

G

Gazal 35, 70
Gazali 74
Ghouls 58
Ghoul of Pteion 96
Ghoul Shaman 61
Ghulistan 31
Giant Hyena 97
Glowing Globe 70
Green Fire-Stones 113

Green Stone Cities 67

H

High Priest of the Black Ones 80
Historical Nature of the Ruin 5
Hyperborea 31
Hyrkania 32

I

Iranistan 33
Iron Shadows 77
Isle of Iron Statues, The 75
Isle of the Black Ones 78

K

Kaetta 40
Karutonia 27
Khet 83
Khitai 33
Khorala 44
King of the Ghouls 60
Koth 34
Kush and the Black Kingdoms 34
Kuthchemes 41, 86

L

Lanjau 29
Larsha 46
Legends Regarding the Ruins 24
Lemurians of the East 69
Lizard, Monitor 146
Lonika 30

M

Magic & Unusual Items Hidden
in the Ruins 24

Maharashtra 45

Makkalet 32

Mastabas 99

Master of the Crawler 120

Miscellaneous Trap Features 131

Mitraeums 26

Monsters 24, 137

Mount Yimsha 31

Movement Within Ruins 22

N

Nameless Monstrosity From
Hell, The (Zug, the
Dweller Below) 89

Natural Disaster 9

Nebthu 42

Necromantic Lore 136

Nemedia 36

Nerves of Steel 136

Nithia 41

Nordheim 37

O

Ollam-Onga 71

Ollam-Onga's Cult 72

Ophir 37

P

Physical Nature of the Ruin 15

Pictland 38

Pipes of Madness 113

Pool of the Black One 81

Prince Olmec of Tecuhtli
120

Pteion the Damned 93

Pulawer 46

Purple Lotus

Wine 114

Pyramid Complex 106

Pyramid Interiors 107

Pyrrophlagalon 27

Python 36

Q

Qarnak 42

R

Rat Swarm 152

Razadan 33

Repairing and Resetting
Mechanical Traps 130

Rider of Ollam-Onga 72

Rock-Cut Tombs 104

S

Sadoria 48

Sample Traps 131

Sandstorms 98

Saurian of Pteion 97

Scorpion 148

Scorpion Swarm 153

Servitors of Quf-jushke'een 63

Shem 38

Shemite Cities 38

Shemite Temples & Zikkurats
39

Skauraul's Stronghold 41

Snake That Speaks 149

Spider Swarm 153

Stygia 41

Stygian Temples 42

Stygian Tombs 42

Swarm 150

T

Tal'ib 41

Tartarus 29

Tascela 122

Techotl of Tecuhtli 121

Tecuhtli 110

Theringo 37

The Isle of Iron Statues 43

Thugra Khotan (Natohk the
Veiled One) 91

Thuran-on-the-Heights 42

Tlazitlan 117

Tolkemec 123

Tombs & Pyramids 99

Traps 128

Triceratops 144

Triregnum of High Priest
Shrayeent 58

Turan 42

Tyrannosaurus 145

U

Uskuth Hill 30

V

Valadelad 48

Valeria of the Red Brotherhood
125

Vendhya 44

Viper Swarm 154

W

Wand of Crimson Fire 114

War 11

Water of Zarkheba 50

Were-Hyenas 53

Winged One, The 52

X

Xapur the Fortified 43

Xuchotl 36, 109

Xuthal 36

Y

Yanaidar 33

Z

Zamora 45

Zingara 47

CONAN[®]

STYGIA - SERPENT OF THE SOUTH

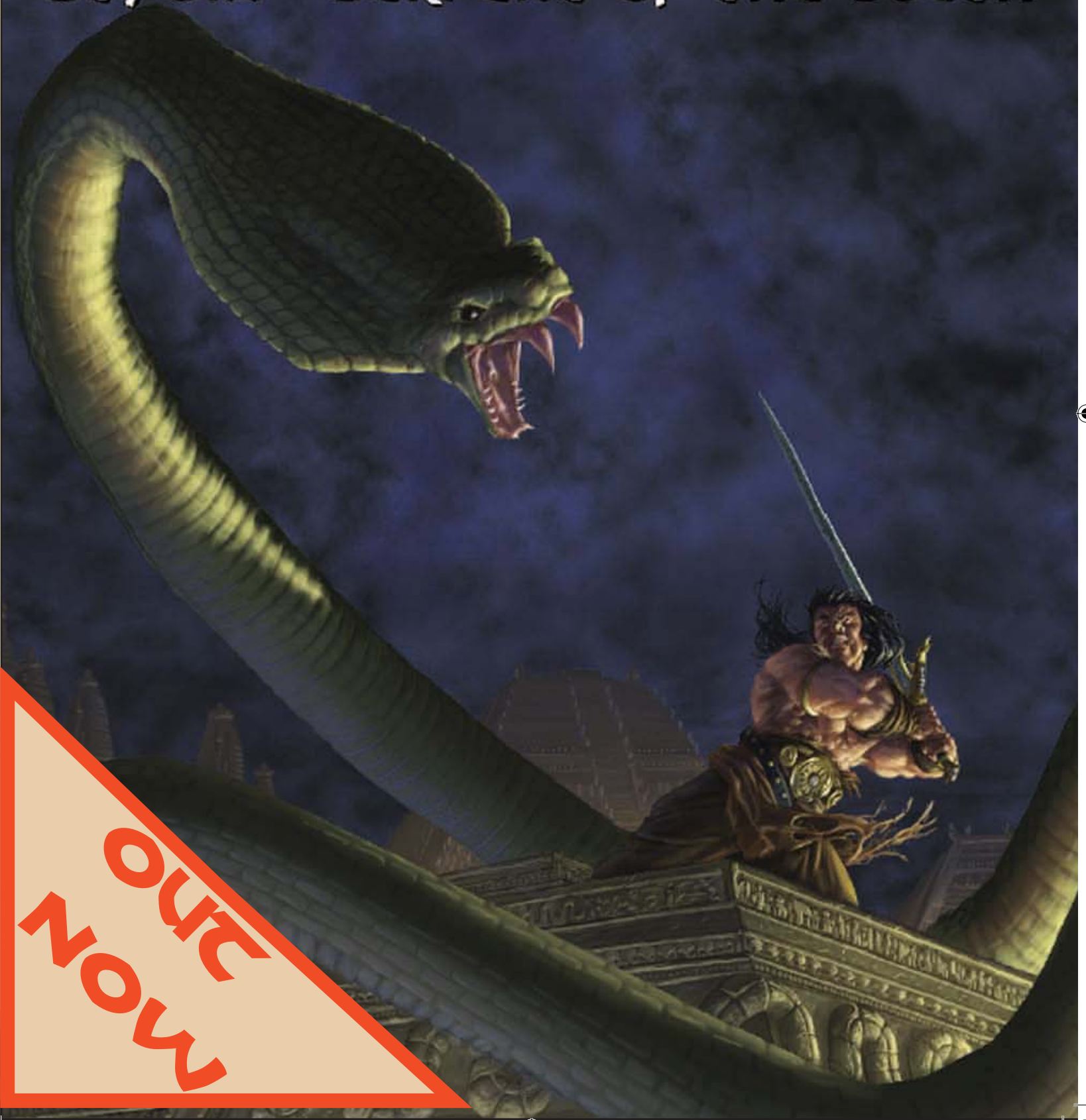

**NOW
OUT**

CONAN[®]

FAITH AND FERVOUR

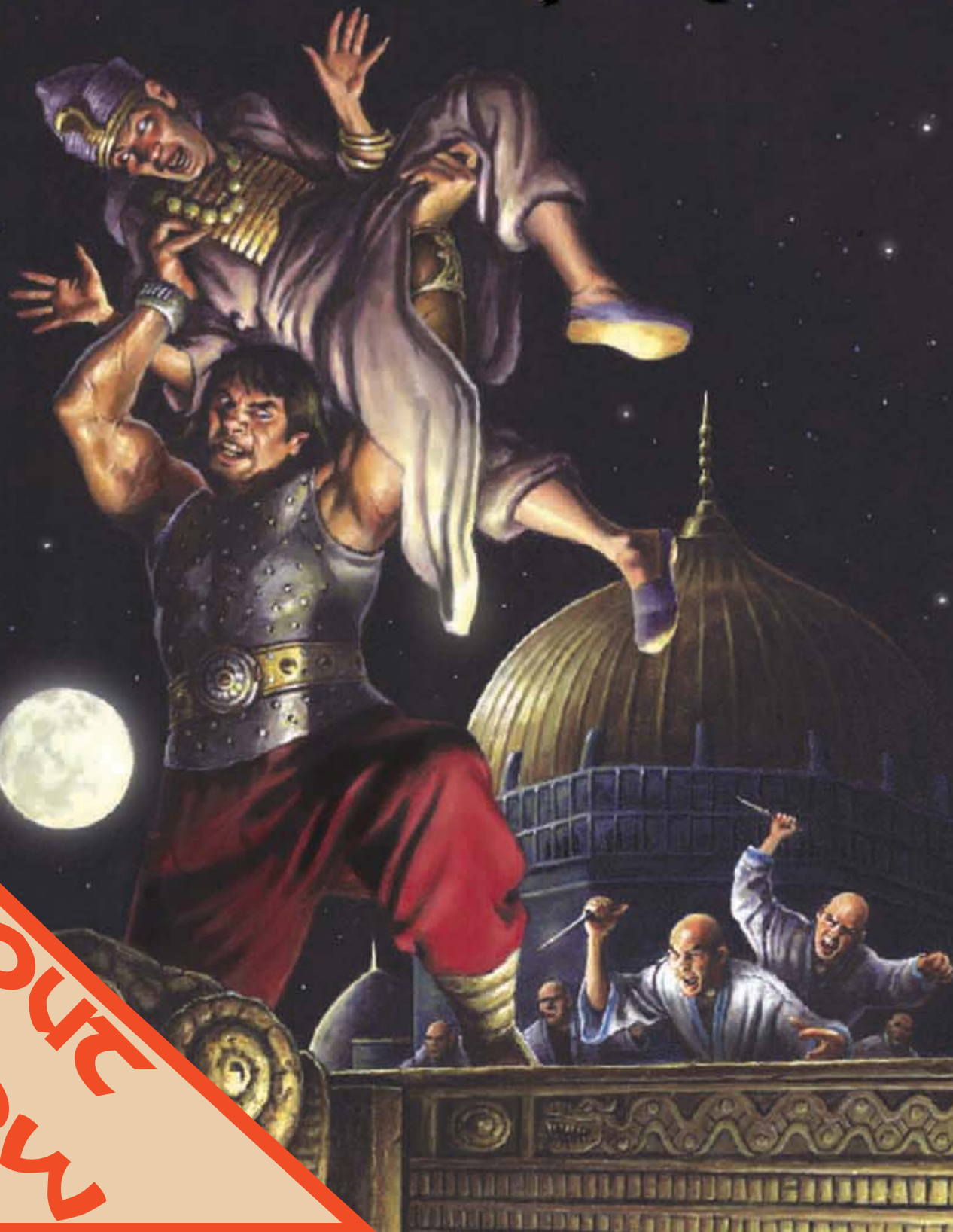

NOW
OUT

Signs & Portents

Roleplayer

Mongoose Publishing's
online magazine

Packed full of articles, scenarios,
previews, hints, tips and lots more!

CONAN
THE ROLEPLAYING GAME

Babylon 5
Roleplaying Game

STARSHIP TROOPERS
THE ROLEPLAYING GAME

And many more!

FREE EVERY MONTH FROM
MONGOOSE PUBLISHING!

Signs & Portents Roleplayer
For all your
Roleplaying needs!

Where does your quest begin?

www.mongoosepublishing.com

QUILLIAMS
2005

OPEN GAME LICENSE Version 1.0a
The following text is the property of Wizards of the Coast, Inc. and is Copyright 2000 Wizards of the Coast, Inc ('Wizards'). All Rights Reserved.

1. Definitions: (a) 'Contributors' means the copyright and/or trademark owners who have contributed Open Game Content; (b) 'Derivative Material' means copyrighted material including derivative works and translations (including into other computer languages), potation, modification, correction, addition, extension, upgrade, improvement, compilation, abridgment or other form in which an existing work may be recast, transformed or adapted; (c) 'Distribute' means to reproduce, license, rent, lease, sell, broadcast, publicly display, transmit or otherwise distribute; (d) 'Open Game Content' means the game mechanic and includes the methods, procedures, processes and routines to the extent such content does not embody the Product Identity and is an enhancement over the prior art and any additional content clearly identified as Open Game Content by the Contributor, and means any work covered by this License, including translations and derivative works under copyright law, but specifically excludes Product Identity. (e) 'Product Identity' means product and product line names, logos and identifying marks including trade dress; artifacts; creatures characters; stories, storylines, plots, thematic elements, dialogue, incidents, language, artwork, symbols, designs, depictions, likenesses, formats, poses, concepts, themes and graphic, photographic and other visual or audio representations; names and descriptions of characters, spells, enchantments, personalities, teams, personas, likenesses and special abilities; places, locations, environments, creatures, equipment, magical or supernatural abilities or effects, logos, symbols, or graphic designs; and any other trademark or registered trademark clearly identified as Product identity by the owner of the Product Identity, and which specifically excludes the Open Game Content; (f) 'Trademark' means the logos, names, mark, sign, motto, designs that are used by a Contributor to identify itself or its products or the associated products contributed to the Open Game License by the Contributor (g) 'Use', 'Used' or 'Using' means to use, Distribute, copy, edit, format, modify, translate and otherwise create Derivative Material of Open Game Content. (h) 'You' or 'Your' means the licensee in terms of this agreement.

2. The License: This License applies to any Open Game Content that contains a notice indicating that the Open Game Content may only be Used under and in terms of this

License. You must affix such a notice to any Open Game Content that you Use. No terms may be added to or subtracted from this License except as described by the License itself. No other terms or conditions may be applied to any Open Game Content distributed using this License.

3. Offer and Acceptance: By Using the Open Game Content You indicate Your acceptance of the terms of this License.

4. Grant and Consideration: In consideration for agreeing to use this License, the Contributors grant You a perpetual, worldwide, royalty-free, non-exclusive license with the exact terms of this License to Use, the Open Game Content.

5. Representation of Authority to Contribute: If You are contributing original material as Open Game Content, You represent that Your Contributions are Your original creation and/or You have sufficient rights to grant the rights conveyed by this License.

6. Notice of License Copyright: You must update the COPYRIGHT NOTICE portion of this License to include the exact text of the COPYRIGHT NOTICE of any Open Game Content You are copying, modifying or distributing, and You must add the title, the copyright date, and the copyright holder's name to the COPYRIGHT NOTICE of any original Open Game Content you Distribute.

7. Use of Product Identity: You agree not to Use any Product Identity, including as an indication as to compatibility, except as expressly licensed in another, independent Agreement with the owner of each element of that Product Identity. You agree not to indicate compatibility or co-adaptability with any Trademark or Registered Trademark in conjunction with a work containing Open Game Content except as expressly licensed in another, independent Agreement with the owner of such Trademark or Registered Trademark. The use of any Product Identity in Open Game Content does not constitute a challenge to the ownership of that Product Identity. The owner of any Product Identity used in Open Game Content shall retain all rights, title and interest in and to that Product Identity.

8. Identification: If you distribute Open Game Content You must clearly indicate which portions of the work that you are distributing are Open Game Content.

9. Updating the License: Wizards or its designated Agents may publish updated versions of this License. You may use any authorised version of this License to copy, modify and distribute any Open Game Content originally distributed under any version of this License.

10. Copy of this License: You MUST include a copy of this License with every copy of the Open Game Content You Distribute.

11. Use of Contributor Credits: You may not market or advertise the Open Game Content using the name of any

Contributor unless You have written permission from the Contributor to do so.

12. Inability to Comply: If it is impossible for You to comply with any of the terms of this License with respect to some or all of the Open Game Content due to statute, judicial order, or governmental regulation then You may not Use any Open Game Material so affected.

13. Termination: This License will terminate automatically if You fail to comply with all terms herein and fail to cure such breach within 30 days of becoming aware of the breach. All sublicenses shall survive the termination of this License.

14. Reformation: If any provision of this License is held to be unenforceable, such provision shall be reformed only to the extent necessary to make it enforceable.

15. COPYRIGHT NOTICE
Open Game License v 1.0a Copyright 2000, Wizards of the Coast, Inc.

Modern System Reference Document Copyright 2002, Wizards of the Coast, Inc.; Authors Bill Slavicek, Jeff Grubb, Rich Redman, Charles Ryan, based on material by Jonathan Tweet, Monte Cook, Skip Williams, Richard Baker, Peter Adkison, Bruce R. Cordell, John Tynes, Andy Collins, and JD Wiker.

System Reference Document Copyright 2000-2003, Wizards of the Coast, Inc.; Authors Jonathan Tweet, Monte Cook, Skip Williams, Rich baker, Andy Collins, David Noonan, Rich Redman, Bruce R. Cordell, based on original material by E. Gary Gygax and Dave Arneson.

A Magical Medieval Society: Western Europe Copyright 2003, Expeditionary Retreat Press; Authors Suzi Yee and Joseph Browning
Cityworks Copyright 2003, Fantasy Flight Publishing, Inc.; Mike Mearls
Darkness & Dread Copyright 2004, Fantasy Flight Publishing, Inc.; Mike Mearls
Monster's Handbook Copyright 2002, Fantasy Flight Publishing, Inc; Mike Mearls
Nyambe: African Adventures Copyright 2002, Trident Inc. db/a Atlas Games; Christopher W. Dolunt
Path of the Sword, Copyright 2002, Fantasy Flight Publishing, Inc.

Conan the Roleplaying Game is (C) Conan Properties International LLC.

Conan: Ruins of Hyboria is (C) 2006 Conan Properties International LLC. CONAN(R), CONAN THE BARBARIAN(R) and related logos, character, names, and distinctive likenesses thereof are trademarks of Conan Properties International LLC unless otherwise noted. All Rights Reserved. Mongoose Publishing Ltd Authorized User.

CONAN[®]

RUINS OF HYBORIA

IT WAS BUT THE GHOST OF A CITY ON WHICH THEY LOOKED WHEN THEY CLEARED A JUTTING JUNGLE-CLAD POINT AND SWUNG IN TOWARD THE IN-CURVING SHORE. WEEDS AND RANK RIVER GRASS GREW BETWEEN THE STONES OF BROKEN PIERS AND SHATTERED PAVES THAT HAD ONCE BEEN STREETS AND SPACIOUS PLAZAS AND BROAD COURTS. HERE AND THERE BUCKLING TOWERS REELED DRUNKENLY AGAINST THE MORNING SKY, AND BROKEN PILLARS JUTTED UP AMONG THE DECAYING WALLS. IN THE CENTRE SPACE A MARBLE PYRAMID WAS SPIRED BY A SLIM COLUMN, AND ON ITS PINNACLE SAT OR SQUATTED SOMETHING THAT CONAN SUPPOSED TO BE AN IMAGE UNTIL HIS KEEN EYES DETECTED LIFE IN IT.

What lurks in the darksome ruin over that rise? You may not want to know, but you yearn for the treasure so badly you will brave the nameless slimes and unspeakable horrors of those ancient remains.

There is something irresistible in the allure of decaying ruins and ancient places. They are testaments to ingenuity, yet the civilisations that built them fell, regardless of their creativity and intelligence. The ancient places of the world have an awesome power to impress and overwhelm in a way newer constructions can never hope to. The air of decay surrounding such places, the sheer sense of history pervading these old locations, works to stimulate the dark corners of the imagination and conjures phantoms both real and imagined.

Extensively researched, this book is intended to give Players and Games Masters of Conan the Roleplaying Game the resources to bring the ruins of the Hyborian age to life, including a ruin generator, maps and monsters.

U.S. \$29.95

MGP
7724



MONGOOSE
PUBLISHING

