

VESNA THAW



POST-SOVIET ROBOT ACTION IN A POST-APOLYPTIC WORLD

ndp microgames
issue #2

A Lighthearted Story Game For 2-5 Players
Nathan D. Paoletta

THE BACKGROUND

Vesna Thaw is a game about two things: giant radiation-powered Robots, and trying to build a new world out of the ashes of the old. It takes place in post-nuclear, post-Soviet Russia. The vestiges of Russian civilization survive in underground bunkers built a decade ago in preparation for the possibility of atomic war. That war has come and gone, and the individual communities, unable to communicate and cut off from physical contact by the radiation of the surface world, are dwindling. No single community has all of the resources it needs in order to survive for much longer. As the remnants of the apocalypse fade, the surface becomes marginally safer. The old Soviet communication networks have started to come back online just enough so that these communities know they are not alone.

Many communities take whatever mechanical and electrical knowledge and materials they can scrape together and construct oversized mechanical vehicles with which to navigate the hazards of the surface. These constructs, called simply Robots by the people, are the only way to bridge the gaps between communities. The Pilots that have volunteered to take them out into the wild are both honored, and regarded as fools.

In this game, each player will play the role of one of these Pilots. You will try to solve the problems your community faces, reach out to alien communities, and brave the dangers of the surface in your Robot. The game will follow a similar trajectory for each Pilot – your early attempts will be met with little success, but once you focus your effort and firm your resolve, you will be able to get done what you set out to do. The life of a Pilot is necessarily constrained by your constant exposure to radiation, however. Your story will end in a blaze of glory.

This game shares many similarities with roleplaying games. Each player takes on the role of one character to play for the duration of the game, and you use polyhedral dice, pencils, paper, and your imagination to play. It's also similar to story games in that the focus of the game is less on achieving mechanical rewards for your character and more about creating a coherent and entertaining story for yourself, as well as for the group you are playing with.

The game is designed with a definite end point, which will probably be reached after about 2-4 hours of play.

HOW TO START THE GAME

You begin this game by gathering a group of people who want to play. The game is designed for between 2 and 5 players. Everyone should be familiar enough with the backstory to get excited about giant Robots, if nothing else.

Each player gets a Character Sheet. This is used to record most of the pertinent information about your Pilot, your Community Aspects, and the Hazards that you will use to make the lives of the other Pilots difficult. The group will also need a good number of four-sided (d4), six-sided (d6), eight-sided (d8) and ten-sided (d10) dice. Everyone will need a pencil – not a pen! You will be using the eraser. You can copy Character Sheets from the one in this issue, or download them from ndpdesign.com.

The first step is to choose a Name for your Pilot. Most of these communities had at one time been part of the Soviet Union, but you can choose any kind of name you

QUICK REF - STARTING

- ★ Choose a Name and Callsign for your Pilot
- ★ Draw your Robot. It is made of up 6 Elements. You draw (7 minus the number of players) Elements, then each other player draws 1 Element.
- ★ Assign 1 die to each Element. You have 2d4, 2d6, and 2d8 to assign. Smaller is better. You will be rolling these dice when your Robot is fighting, or when you're using your Robot to achieve things.
- ★ Assign starting scores to Community Aspects: Technology Level, Leadership, Population, and Stability. Your best is 3, your worst is 1, the others are 2. You will be rolling these dice when interacting with your community.
- ★ Write down starting Hazard scores: 3, 3, 2, 1. Write in any initial Hazard ideas. (You can also define Hazards during play). You will be spending these points to make other Pilots face Hazards during their turns.

This game was originally written for the "Reversed Engineer" design contest, run by Kevin Allen Jr. in August/September of 2006. I was randomly assigned a character sheet designed by Martin O'Leary and designed this game around that sheet.

wish. You should also choose a Callsign for your Robot. Some communities have multiple Pilots but only one Robot, and many Pilots only actually ever interact via their Robots and call each other by their Robot names.

Each of your Pilots should be from a different community, though they can be close to each other or overlap in territory if you want. If you are using one of the maps, each player should circle a place on the map where their Pilot's community is physically located. Feel free to doodle on, mark up and otherwise use the maps as inspiration for your game!

Next step is to draw your Robot in the box provided. Everyone is going to have a hand in everyone else's Robot, both because using the creativity of your friends is cool, and to emphasize the kitbashed nature of how these Robots actually look out on the frozen steppe.

Your Robot is going to have six main Elements, things like powerplants, weapons, legs or wheels, a cockpit, and so on. You draw a number of those Elements equal to 7 minus the number of players for the game – so, if your group has 3 players, draw 4 of the Elements of your Robot. Each other player gets to draw 1. You get to choose what order Elements get drawn in – whether you want to establish a core and have your friends embellish it, or whether you want to work off of the material they give you, or a combination of the two. Be creative! Be funky! Don't worry about having good drawing skills. The Robots are built out of industrial waste barrels, broken turbines, rolls of barbed wire and rusty firehoses. Having a rough look to your Robot is great. Check out the Rogue's Gallery later in this issue for inspiration.

Once every Robot has been fully drawn, you all get your sheets back. Now, draw a line to each Element. On each line, you write the size of the die you are assigning to that Element. You get two d4s, two d6s and two d8s to assign between your six Elements, and each Element gets a single die. In this game, low numbers are good, and the smaller the die the better. You will be using these dice when you can bring that Element of your Robot into the scene in which you act, as well as during Robot battles. So, if you give your d4s to things like weapons and armor, you'll probably be bringing your Robot into scenes as something threatening or imposing; if you put them into something like jumpjets or submersion gear, then you'll

be doing better in scenes about getting from one place to another or surviving in the harsh environment.

Next, assign ratings to your Community Aspects. These Aspects describe the strengths and weaknesses of your Pilot's community. Like the Elements of your Robot, these Aspects give you dice to roll when appropriate in scenes. The four boxes along the top of the sheet represent the key aspects of your community: Technology Level, Leadership, Population, and Stability. Assign the strongest Aspect of your Community a rating of 3, the weakest 1, and the other two 2. All community dice are d4s (you can remember that because the box has 4 sides), so you just need to write the assigned number in each box.

★ A community with a high Technology Level still has access to some of the Soviet-era tech in good working order, or it has a number of skilled mechanics, technicians and scientists among its ranks. You can bring in Technology dice when the scene concerns technology, making repairs, or interacting with scientists and technicians.



★ A community with a high Leadership has a leadership system that works well and gets things done. It may be concentrated or distributed, democratic or communistic, but whatever it is, it works. You can bring in Leadership dice when a scene concerns working for or against community leadership, or when interacting with the leaders of the community.



★ A community with a high Population has either a large or an extremely productive and robust group of members. It may be large and versatile or small but very skilled and motivated. You can bring in Population dice when a scene concerns issues related to population growth or control, or when interacting with the general population of the community.



★ A community with a high Stability has a good relationship between its leadership and its population. Stability usually, but not necessarily, follows from having high scores in both of those. A community with a high Stability has a solid working relationship between the



THESE BOXES CONTAIN EXAMPLES OF HOW THE GAME COULD BE PLAYED. THEY WILL CONCERN A GROUP OF THREE PLAYERS: DAMIEN, JOHN AND MARY.

VESNA THAW

leadership and the people, or has some other factor that helps the community endure. You can bring Stability dice into a scene when it concerns issues directly related to its stability, when trying to shore up the community, or when trying to drive a wedge between the population and the leadership.

Again, how you assign your Community Aspects will shape what kinds of scenes you will probably want for your Pilot – high Technology Level and Stability could describe a community that has a Soviet tech stash as the core of its existence as well as the issues that creates; while a high Leadership and Population would be more about how the two parts of the community relate to each other, for good or ill. Notice that you will be getting dice

just for the presence of that Aspect of the community in the scene, whether you are supporting it or pushing against it.

The final step to filling out your sheet is the 5 vertical stars underneath your Community Aspect boxes. These are where you will record Hazards, the monsters, obstacles, and dangers that you will be using to make the lives of the other Pilots harder. All Hazard dice are d10s (which you can remember because the stars have 10 sides). Like Community Aspects, you assign numbers to your Hazards: 3, 3, 2, 2 and 1. Unlike Aspects, this number is not the number of dice you will roll, but rather the number of times you get to invoke that Hazard.

Next to each Hazard, you need to write a description of that that Hazard actually is – a radioactive snowstorm? A mutated cosmonaut/yeti? A niggling Robot malfunction? A displeased Pilot's mistress? You do NOT need to nail down all 5 Hazards right now. If you have an idea for a Hazard you will definitely want in play, you should write it down – but if you don't have anything concrete in mind, you can wait until an opportune moment in play. The first time you invoke a given Hazard, you must describe it, and that's what that Hazard is for the rest of the game. Of course, if you get a good idea for a blank Hazard at any point, feel free to write it down. You should all talk about what Hazards you're taking as you write them down, and try not to overlap too much.

The three Scene Tracks start the game empty, with no marks.

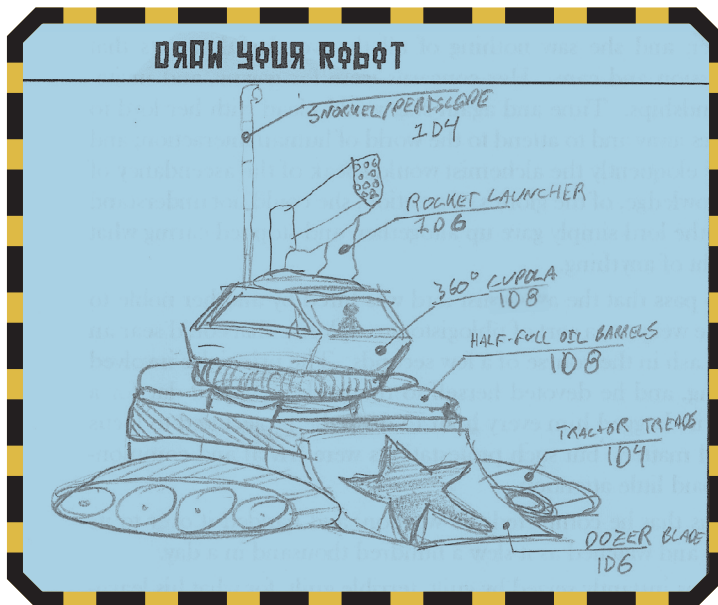

DAMIEN CREATES HIS PILOT. HE KNOWS THAT HE WANTS DMITRI TO BE THE PILOT'S FIRST NAME, AND HE REFERENCES A NAME GENERATOR FOR THE REST. HE ENDS UP WITH DMITRI VALENTINOVICH ROKISSOVSKY, AND HE DECIDES HIS CALLSIGN IS RASKOLNIK.

THERE ARE THREE PLAYERS IN TOTAL, SO DAMIEN DRAWS (7-3 =) 4 ELEMENTS OF HIS ROBOT. HE DRAWS TRACTOR TREADS, A 360° CUPOLA, A RACK OF HALF-FULL OIL DRUMS AS THE TORSO, AND A DOZER BLADE. JOHN ADDS A ROCKET LAUNCHER ON TOP, AND MARY ADDS A SNORKEL/PERISCOPE FOR LAKE EXPLORATION.

DAMIEN GIVES THE TANK TREADS AND PERISCOPE D4S, THE ROCKET LAUNCHER AND DOZER BLADE D6S, AND THE COCKPIT AND OIL BARRELS D8S, INDICATING THAT HE'S MORE INTERESTED IN HIS ROBOT AS TRANSPORTATION AND SURVIVAL THAN COMBAT.

DAMIEN MAKES HIS COMMUNITY ASSIGNMENTS: 2 TO TECHNOLOGY LEVEL, 1 TO LEADERSHIP, 3 TO POPULATION, AND 2 TO STABILITY. HE DESCRIBES HIS COMMUNITY AS ONE THAT HAS A LEADING COUNCIL THAT IS MORE CONCERNED WITH MAINTAINING THEIR POSITIONS THEN TRYING TO HELP THE PEOPLE, AND THE POPULATION IS FAIRLY SIZEABLE – AND THUS NOT AS MANAGEABLE AS THE COUNCIL WOULD LIKE.

FINALLY, DAMIEN FILLS IN HIS HAZARDS. HE WRITES DOWN HIS 3, 3, 2, 2, 1. HE DESCRIBES THE FIRST 3 AS "MUTATED SNOW YETI", BECAUSE HE DEFINITELY WANTS TO SEE SOME OF THOSE IN THE GAME, AND HE GIVES THE 1 TO "CRITICAL ROBOT FAILURE" – HE WANTS TO DO THIS ONCE, BUT HE DOESN'T WANT IT TO COME UP OVER AND OVER. HE SAVES THE REST FOR IDEAS THAT COME UP DURING PLAY.

If someone in particular wants to start the game by framing the first scene, then they should do so. If this is not the case, the player with the most facial hair starts. Play proceeds clockwise, with each player framing a scene for their Pilot in turn.

HOW TO PLAY THE GAME

The game is played by each player setting up (“framing”) a scene of play for their Pilot. In each Pilot’s scene, the other players will play NPC’s (Non-Pilot Characters) as well as describe and play the Hazards that get in the Pilot’s way. The three scene tracks show how far along the game each Pilot has progressed. The game is over once a Pilot has reached the sixth hex of one of the tracks, and they go out in a Blaze of Glory.

There are three kinds of scenes in this game: Color, Conflict, and Action. Color scenes establish backstory, show off relationships, or demonstrate Robot or Pilot badassery. Conflict scenes showcase a conflict of interest between Pilots, between a Pilot and their community, or between a Pilot and an alien community. Action scenes concern physical confrontation, whether in or out of a Robot. Of course, any of these scenes can take place with the Pilot in their Robot.

You start the game without any octagons filled in, as no scenes have yet happened. When you frame a scene, you declare which kind of scene it is, and check or fill in the left-most octagon on the corresponding track. This becomes your Target Number – any die you roll in the scene that show that number or lower counts as a success. You always roll 1d8 for anything you need to roll in the scene, trying to get your Target Number or lower. (You can remember it’s a d8 because your Scene Track boxes have eight sides.)

You also have another player describe a Hazard you will be facing in that scene. To represent the Hazard, you will be rolling 1d10 in addition to your base 1d8. You may also be able to bring in Aspect and Robot dice. Before continuing the rules for scenes, you should know what it means to make a roll.

MAKING A ROLL

Whenever the rules say to make a roll, you roll a number of dice, trying to get equal to or below your target number on each one. You check Scene Track boxes when you begin the scene, so your first scene will be against TN 1. You always roll 1d8 for the scene, and 1d10 for the Hazard you are facing. If you can bring in any of your Community Aspects (Technology, Leadership, Population or Stability), you roll that number of d4s as well. If you are in your Robot, or the scene is about your Robot in particular, you can bring in any appropriate Robot Element dice. Other players can use more Hazards to make the roll more difficult for you, giving you more d10s to roll. Each other player can give you one Hazard per roll (so, any given roll can have a number of d10s on it equal to the number of other players). The initial Hazard counts – that is, that player can’t introduce another Hazard later in the scene.

QUICK REF - ROLLING

- ★ Each player has a scene for their Pilot in turn. The other players play NPCs and offer Hazards.
- ★ Each scene is either a Color, Conflict or Action scene. You can also use your Robot for a scene. You declare the kind of scene at the beginning and fill in the left-most space on the corresponding scene track listed on your sheet.
- ★ You ask another player to offer a Hazard for the scene. They spend a Hazard point and describe it.
- ★ When you make a roll during your scene, you roll 1d8 + 1d10 + any Aspects (d4s) that apply. If it’s a Robot scene, you also add any Robot components that apply.
- ★ Other players can describe how additional Hazards make what you are attempting more difficult. They spend a point from their Hazard and give you 1d10. Each other player can bring in one Hazard per roll (the initial Hazard counts for this).
- ★ You are trying to get a Target Number equal to the number of checks you have in the current scene track. Every die result equal to or lower than your TN is a success.
- ★ If any die rolls its maximum number (4 for d4, 6 for d6, etc.), your community has a problem (even if the roll was a success). Subtract 1 from any Aspect. Only subtract 1, even if more than 1 die maxed out.

Once you've determined which dice you get, you roll them all at once. Any die result equal to or below your TN is a success. Your number of successes equates to how well you do at the roll – one success means that you do marginally well, two that you do acceptably, three that you do well, four that you do very well, and five or more is a smashing success. There are other mechanical effects for success, each of which is covered in the section describing that kind of roll.

As you can see from the Target Number progression, the game follows a predictable trajectory. The Pilots start off doing poorly at whatever they are attempting, but the more they do the better they become at doing it. By the later scenes of the game Pilots will probably be succeeding at everything they attempt, which is all leading up to the final flameout of each Pilot ending the game in a blaze of glory. The question is, will your Pilot achieve anything important in the time he has?

There is one complication, though. If you roll the highest number a die can roll (4 on a d4, 6 on a d6, 8 on a d8, 10 on a d10) your community has a problem. Whether you succeed or not at whatever you're doing, your community is facing trouble. You must subtract one from one of your Community Aspects, and describe what the problem is, and how it relates to that Aspect. If you can bring in the action you were taking and link it to the Community's problem, so much the better. You only subtract 1, even if you rolled multiple maxed-out numbers. If an Aspect hits 0, you can no longer bring it into rolls, and you cannot subtract from it further.

SCENES IN GENERAL

Framing a scene involves setting the location (both physical and temporal), any NPCs present in the scene, and any action or situation that is immediately facing your Pilot. This can be simple ("So I'm on the surface, trying to track down those life signs that showed up on the machines back home") or complex ("I'm facing the tribunal that leads my community the morning after the police force discovered I exited the compound without leave. The premier of the tribunal, who used to be my wife, begins to read the list of charges against me.")

You can frame your own scenes however you want, bringing in any amount of backstory or relationships

with NPCs. Any NPCs in the scene are played by the other players – you get to assign them if nobody volunteers for one. In addition, you pick one of the other players, and they spend a point from one of their Hazards and describe how it will make your Pilot's life more difficult.

Scenes should generally be short and to the point – set up the scene, play out the interactions of the characters until you need to find out what happens next, roll your dice, and describe the aftermath. If continuing on with a scene would involve changing the locale, major NPCs or the situation to something different, this usually means that you should end that scene.

You always frame scenes for your Pilot, and you never frame scenes for other Pilots. You can frame another Pilot into your scene, but only if you have that Pilot's players permission. In the unlikely event that another player has no Hazard points left, you can't ask them for a Hazard.

QUICK REF - SCENES

- ★ Color scenes help you move more quickly through your other scenes. Roll after you describe how your actions help you out later; if you succeed, check off the left-most space of either other track. If you lose, do nothing.
- ★ Color scenes can repair your Robot. If you succeed, instead of checking off a scene hex, erase the flames from a damaged or irradiated component of your Robot.
- ★ Conflict scenes are the way your Pilot gets something they want over another character's objection. Roll once the conflict comes to a decision point. If you succeed, your Pilot gets what they want. Add 1 to any Community Aspect. If you fail, subtract 1 from an Aspect you used in the roll.
- ★ Action scenes are where you have a physical fight. This can be another player's Pilot, or another player portraying an NPC or a Hazard. If you fight a Hazard, the owner of that Hazard must use it against you for your roll. If you succeed, you get to add 1 to any of your Hazards. If you lose, the other player gets to erase a tick from one of your tracks – their choice.
- ★ If you want to have a Robot fight, check off an Action scene and use the Robot Fight rules.

COLOR SCENES

Color scenes are all about establishing stuff in the game that surrounds the real action – fictional details, circumstances of your Pilot's life, descriptions of the community or the wastelands on the surface, or anything else that could impact the rest of the game.

The goal of a Color scene is to make you more effective in your other scenes. On a successful Color scene roll, you get to tick off the left-most hex of either of the other scene tracks. You should link the color you're establishing with the scene to the kind of scene corresponding to that track, but this isn't a requirement. **Your next scene must correlate to the track you filled in.**

Color scenes are also where you repair your Robot. If your Robot has any irradiated or damaged parts, instead of checking in a scene hex, you repair that part as the result of the color scene, restoring its original die. Since you're working on your Robot, you can roll another Robot die if it would reasonably help with the repairs (like if it has a self-repairing carapace or a motorized arm or something).

Hazards in Color scenes should generally be environmental or abstract things that interfere with your Pilot's vision of a better world.

CONFLICT SCENES

A Conflict scene is a scene that concerns a non-physical or non-violent confrontation with someone or something that opposes the interests of the Pilot. Conflicts are

always binary and opposed – there is something that your Pilot wants that the other person doesn't want. You can frame the scene by describing the conflict at the start, or by saying "This is a Conflict scene with (NPC), lets play until a conflict comes up." Generally, conflicts should have something to do with your community, directly or indirectly. Remember to roll dice for each Community Aspect pertaining to the conflict.

Once you are ready to resolve a conflict of interest one way or another, you roll. If you succeed, you get what you want! Also, you get to add 1 to any of your Community Aspects. If you fail, the opposition gets what it wants. Also, you must subtract 1 from any Aspect that contributed dice to your roll. If you didn't bring in any Aspect, it's your choice.

You can have multiple conflicts in a Conflict scene, if you happen to establish another conflict of interest within the scene once the first is resolved.

Hazards in Conflict scenes tend to be the NPCs involved, or attributes of the community that would negatively impact the Pilot.

ACTION SCENES

In an Action scene, you have a physical fight. You can fight another Pilot, someone from your own or an alien community, or a Hazard. You can ask another Pilot if they want to fight, or cast another player as the NPC opposition. You can also ask to fight one of a player's Hazards in particular, and that's the point they spend to

DAMIEN HAS FRAMED A CONFLICT SCENE FOR DMITRI, AND IT'S HIS THIRD CONFLICT SCENE (TN3). HE IS ARGUING WITH ONE OF THE COUNCIL MEMBERS, BEHIND CLOSED DOORS, ABOUT WHETHER THE COMMUNITY CAN AFFORD TO SEND HIM OUT INTO THE WASTES. HE ASKS MARY TO ADD THE HAZARD FOR THE SCENE, AND SHE DEFINES ONE OF HER OPEN HAZARD SLOTS AS "COWARDLY COUNCILMEN." DAMIEN PICKS UP 1d8 AND 1d10 (THE BASE DIE + HAZARD DIE). MARY PLAYS THE COWARDLY NPC, AND THEY HAVE AN IN-CHARACTER ARGUMENT ABOUT DMITRI'S INTENTIONS.

THE ARGUMENT COMES TO A HEAD, AND THEY NEED TO KNOW WHO WINS. DAMIEN SAYS THAT THIS CONFLICT HAS TO DO WITH BOTH THE LEADERSHIP AND STABILITY ASPECTS OF HIS COMMUNITY. THESE ASPECTS GIVE HIM 1d4 AND 2d4, RESPECTIVELY. SO, DAMIEN HAS A POOL OF 3d4, 1d8 AND 1d10, TRYING TO GET 3 OR LOWER ON EACH.

HE ROLLS, GETTING 1, 2, 4 ON THE d4s, 4 ON THE d8, AND 5 ON THE d10. TWO OF HIS DICE ARE LOWER THAN HIS TARGET NUMBER, SO HE DOES FINE IN THE CONFLICT, AND ROLEPLAYS THE WAY HE CONVINCES THE COUNCILMAN NOT TO STAND IN HIS WAY. SINCE HE WON, HE GETS TO ADD 1 TO AN ASPECT, AND HE CHOOSES STABILITY – DMITRI IS GOING OUT IS GOING TO RESTORE CONFIDENCE AMONG THE PEOPLE.

HOWEVER, ONE OF HIS DICE, A d4, MAXED OUT! REGARDLESS OF HIS SUCCESS, THIS MEANS A PROBLEM FOR HIS COMMUNITY. DAMIEN DESCRIBES HOW, AFTER DMITRI DEPARTS, THE COUNCILMAN DECIDES THAT EVERYTHING IS GOING TO HELL ANYWAY, AND HE COMMITS SUICIDE! DAMIEN LOWERS HIS COMMUNITIE'S LEADERSHIP ASPECT TO 0. DAMIEN CAN SEE A PATH FOR DMITRI TO POSSIBLY FILL IN THE POWER VACUUM IN HIS NEXT SEQUENCE OF SCENES...

add a Hazard to your scene. Frame the scene at the start of the fight, including any backstory as to why you are fighting.

Describe the fight until it gets to a climactic moment, then roll. If you win, you win! Hooray! Describe how the fight goes down. You get to add 1 to one of your Hazards. If you lose, your opponent gets to untick the rightmost box on one of your scene tracks, they choose which.

Hazards in Action scenes tend to be about the physical environment, as well as the actual opposition to the character.

If you are in your Robot, and you want to have an Action scene where you fight another Robot, that works a little differently.

QUICK REF - ROBOT FIGHT

- ★ Challenge another Pilot, or have your opponent pick a Robot from the Robot Gallery.
- ★ Roll your normal dice (1d8+ Aspect d4s + Hazard d10s).
- ★ Decide whether you roll first or second.
- ★ Each player describes their Robot fighting, and rolls the corresponding die, in turn.
- ★ Your opponent uses their Robot dice to replace any of your currently showing dice, and you use your dice to replace theirs in turn.
- ★ The fight is over once you both pass on rolling a die, or once one person runs out of Robot dice to roll.
- ★ If a Robot die rolls its highest possible number (4 on a d4, 6 on a d6, etc), it flares up. Draw flames on it, and you cannot use it again (unless repaired by a Color scene).
- ★ Every time you have a flareup, check off one scene track of your choice.
- ★ Your opponents dice do not cause flareups, for either player.
- ★ If you end with successes, you get to destroy one Element of their Robot, OR add 1 to any of your Community Aspects.
- ★ If you end without successes, they get to destroy one Element on your Robot, and they recover one Hazard point.

ROBOT FIGHTS

A Robot Action scene is a Robot battle, Robot vs. Robot. This can be a fight against another Pilot, or you can ask another player to pick a Robot out of the Rogue's Gallery for you to face. The Rogue's Gallery was generated by some of the backers of this game's Kickstarter campaign, and you should feel free to use it to provide Robot enemies for your game! Simply assign 2d4 2d6 2d8 to six Elements of the Robot you pick, and you're ready to fight.

In a Robot Fight, the way you roll works a little differently. You roll your scene (d8) + Community Aspect (d4) + Hazard (d10) dice as per usual. Do not roll your Robot's Element dice yet!

You choose whether to roll first or second. Whoever goes first picks one of their Robot's Elements, describes how it uses that Element, and then rolls the corresponding die. They must then replace one of your currently-showing dice with the die they rolled. You are going to want to replace your high dice with low dice, and your opponent will want to do the opposite. Once both of you decide not to roll any more dice, or one of you runs out of dice, the battle is over.

If you end the battle with successes, you get to destroy an Element on the other Robot, or you can describe how this victory helps out your community, and add 1 to any of your Community Aspects. If you end with a failure, the other Pilot's player gets to destroy an Element on your Robot, and you cannot use that Element for dice until it's repaired in a Color scene. Your opponent also recovers the Hazard point they spent for the scene.

Any time you roll a Robot die and it comes up with its maximum value (4 on a d4, 6 on a d6, 8 on a d8), the radiation powering that part flares up. **Draw little flames on it, and from now on you can't use that part for its die.** You also check the next box of your choice on the Scene Tracks — radiation pumps you up! If an opponent replaces one of your dice with a maximum value, this does not count as a flareup. Your opponent never flares up, only your Robot on your turn.

HOW TO END THE GAME

Once you have checked off the sixth box on one of your Scene Tracks, it's getting to be time for your Pilot to go out in a Blaze of Glory. You can do so immediately, or wait until the other Pilots are ready to go (simply skip your turn to frame a scene). You still offer Hazards to the other Pilots, of course.

The final scene for a Pilot should be about something that's a Big Deal – it's the culmination of the Pilot's story, after all. Finally linking communities together into a New Soviet State, beating back the advance of the army of mutated Snow Yeti, and taking over the leadership of their community in the name of justice are all good Blaze of Glory goals.

You frame the scene with whatever your goal for your Pilot is, and the player with the most remaining Hazards gets to say what will happen to your Pilot when you succeed at that Goal. It's a Blaze of Glory, after all – your Pilot should be consumed by that which he most wants to achieve.

Achieving the Pilot's goal is not easy, though. This is the last scene, so everyone else should feel free to use their

remaining Hazards to make your Pilot's life difficult. In this last scene, and this last scene only, you can use a Hazard to take away one of the dice the Pilot would roll before they roll it, instead of giving them a d10 to roll. The Pilot does not need to specify a track for their final scene. The target number is 6.

If the Pilot does not succeed, then it's all over for that character and for their community. Narrate an appropriately unfortunate ending for your poor Pilot.

If the Pilot does succeed, then he's sacrificed himself for the greater good! This doesn't necessitate the ending of the Pilot's life, but their story is over. They have done all they can do to lead their people into a better world.

Once a Pilot has gone out in a Blaze of Glory, the game is over!

Alternately, if you want to keep playing, continue as normal until ALL Pilots have gone out in their Blazes of Glory. Any players who have already had their Pilot go out can still contribute the remaining Hazards on their sheet and play NPCs.

DAMIEN FRAMES A ROBOT FIGHT, AND HE CALLS OUT MARY FOR SOME ROBOT FIGHTING ACTION. SHE ACCEPTS, AND DAMIEN FRAMES THE SCENE. "MY ROBOT IS ROLLING THROUGH A VALLEY AS I SEARCH FOR THE ENTRANCE TO THE BUNKER THAT I FOUND IN THOSE SOVIET COMPUTERS. I SEE A GLINT OF UNEXPECTED LIGHT THROUGH THE SNOW, AND I SWIVEL TO FACE YOUR ROBOT, WHICH IS CRESTING THE HILL TO MY LEFT. YOU HAVE NO IDEA WHO I AM, BUT I'M GETTING AWFULLY CLOSE TO YOUR HOME, AND YOU DECIDE THAT SAFE IS BETTER THAN SORRY. YOU'RE GOING TO ATTACK FIRST." MARY SAYS, "GOOD THING I HAVE YOU RIGHT WHERE I WANT YOU. THE HAZARD HERE IS 'THIN ICE'."

THIS IS DAMIEN'S 4TH ACTION SCENE, SO HIS TARGET NUMBER IS 4. HE ROLLS HIS 1d8 + 1d10, AND PULLS IN 2d4 FOR HIS COMMUNITY'S TECHNOLOGY LEVEL (I'M A WELL ENGINEERED ROBOT!). JOHN DECIDES HE WANTS IN, AND THROWS DOWN "SUDDEN BLIZZARD" AS A HAZARD. DAMIEN ROLLS 2d4, 1d8, 2d10, GETTING 2, 3, 6, 7, 9 (NONE OF THESE DICE ARE MAXED OUT).

MARY ROLLS FOR HER ROBOT'S MISSILE LAUNCHER (A D6), GETTING 5. SHE REPLACES DAMIEN'S 2, SAYING, "MY INITIAL ROCKET SALVO THROWS UP A WAVE OF PERMAFROST IN FRONT OF YOU, THROWING YOU OFF-BALANCE."

DAMIEN ROLLS 1d6 FOR HIS DOZER BLADE, AND GETS A 4. HE REPLACES HIS 7 WITH THAT 4. "MY DOZER BLADE SLICES THROUGH THE UPTHRUST EARTH, AND I RUMBLE TOWARDS YOU." MARY ROLLS 1d8 FOR HER SENSOR ARRAY, AND GETS AN 8! SHE REPLACES DAMIEN'S 3, DESCRIBING HOW HER SENSORS ALLOW HER TO GET INTO A BETTER POSITION. DAMIEN RESPONDS WITH 1d4 FOR HIS TANK TREADS, BUT HE ROLLS A 4! FLAREUP! HE REPLACES THE 9 WITH IT, AND DESCRIBES HOW THE POWER PLANT OVERDRIVES HIS TREADS, SENDING HIM ROCKETING UP THE HILL BUT DESTROYING THEM IN THE PROCESS. HE DRAWS LITTLE FLAMES ON THEM ON HIS PICTURE, AND CHECKS OFF ONE OF HIS CONFLICT BOXES.

AFTER GOING BACK AND FORTH AGAIN, BOTH PLAYERS PASS. DAMIEN'S DICE NOW READ 2, 4, 4, 5, 8. HE GOT 3 SUCCESSES. HE COULD DESTROY AN ELEMENT ON MARY'S ROBOT, BUT DECIDES HE NEEDS THE HELP IN HIS COMMUNITY INSTEAD. HE ADDS 1 TO HIS TECHNOLOGY ASPECT, AS HE NARRATES THAT THE BUNKER HE WAS LOOKING FOR IS FULL OF ORIGINAL MACHINE PARTS THAT HE CAN BRING BACK TO HIS PEOPLE.

ROGUE'S GALLERY

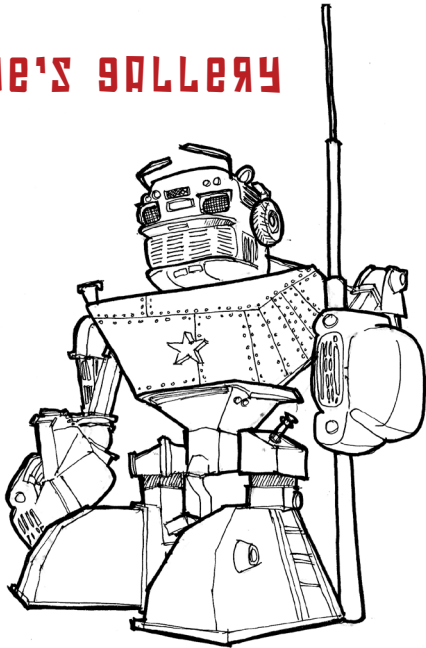

"GUARDIAN" BY JARED AXELROD

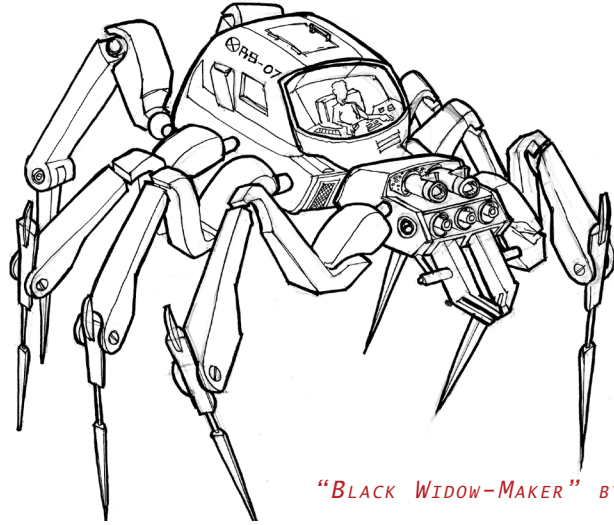

"BLACK WIDOW-MAKER" BY JOE BEASON



"YITHIAN" BY STEVE DEMPSEY

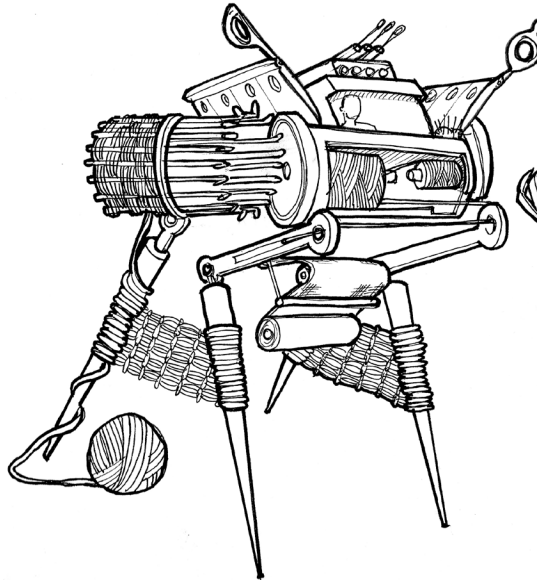

"LOOM" BY STEPHANIE BRYANT

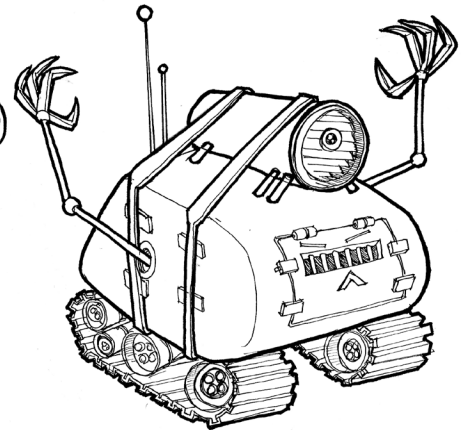

"KLAW" BY GREGOR HUTTON

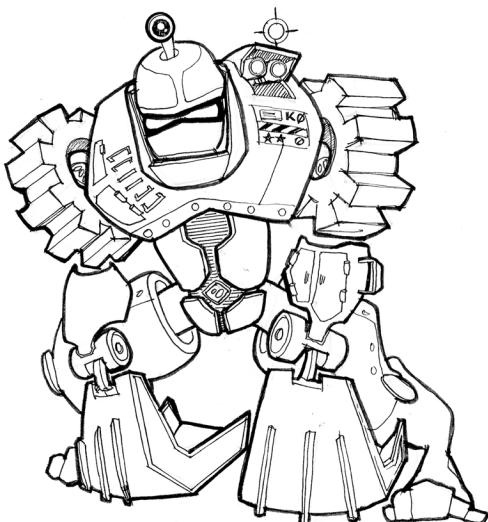

"GORILLA" BY RAY OTUS

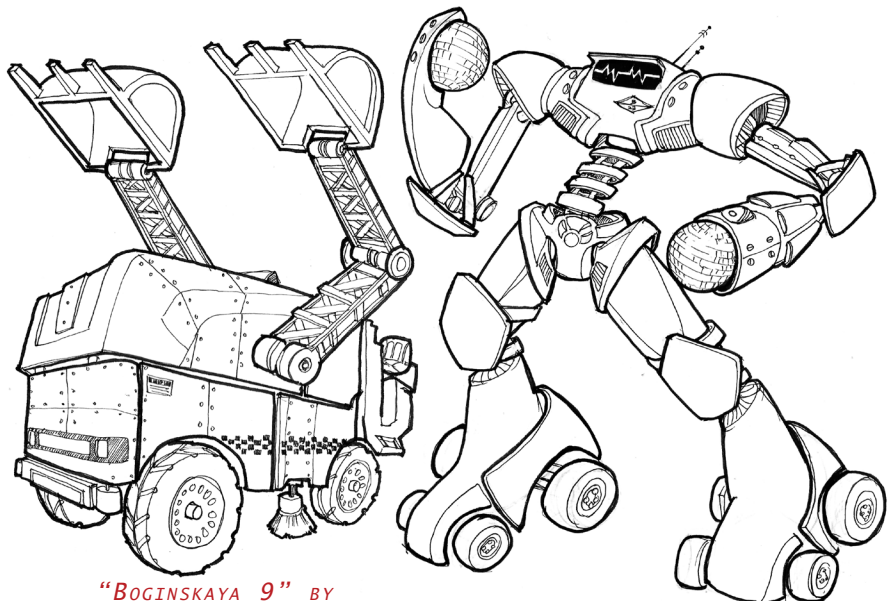

"BOGINSKAYA 9" BY MICHAEL WIGHT

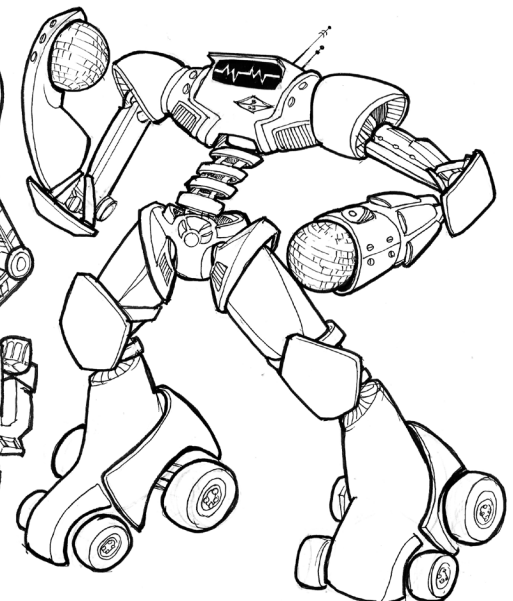

"DISCO" BY SVEN HANNEMAN

Thank you: Anonymous, Anonymous, Aressel, Donnie Clark, Jesse Escobedo, Docteur Half, CS Hearn, Alexandra Hebda, Justin Freyvogel, Alan Jackson, Larry Lade, Patty Kirsch, Jarrod Farquhar-Nicol, Matt Fordham, David M., Louis Morneau, occultsearcher, Ryan Olson, Roy Pollock, Shreyas Sampat, Daniel Winterhalter

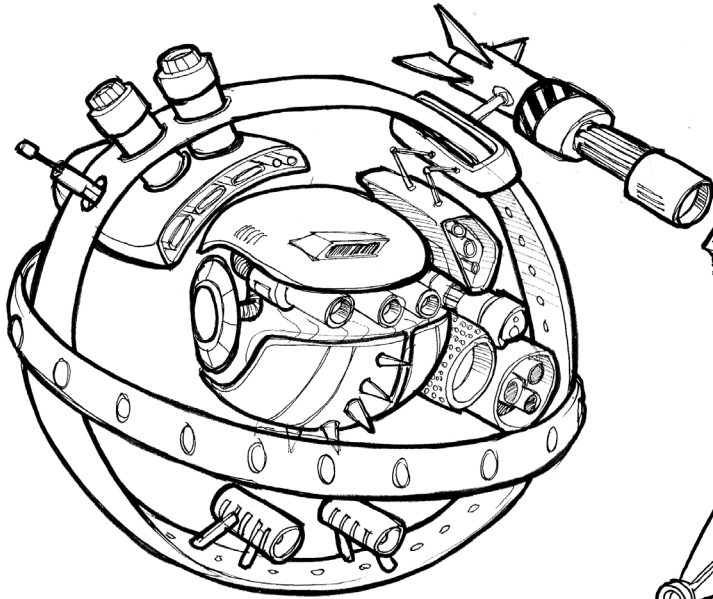

"ORRERY" BY TONY DE FRANCISCO

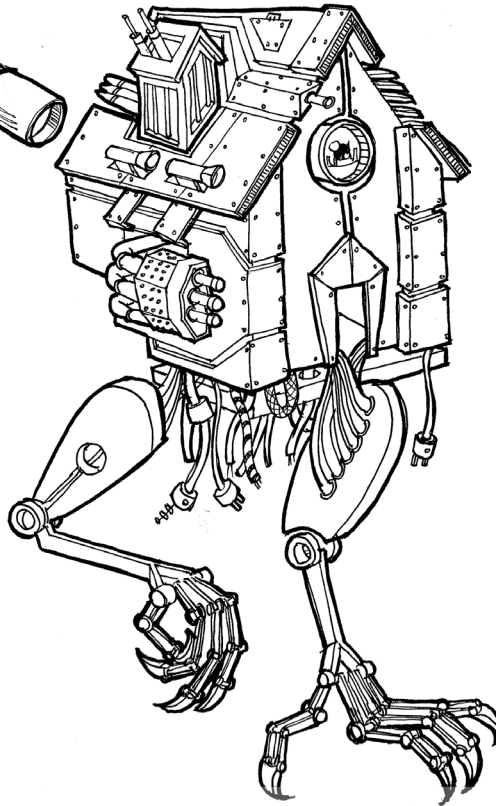

"WITCHBOT" BY LUKE MARTINEZ

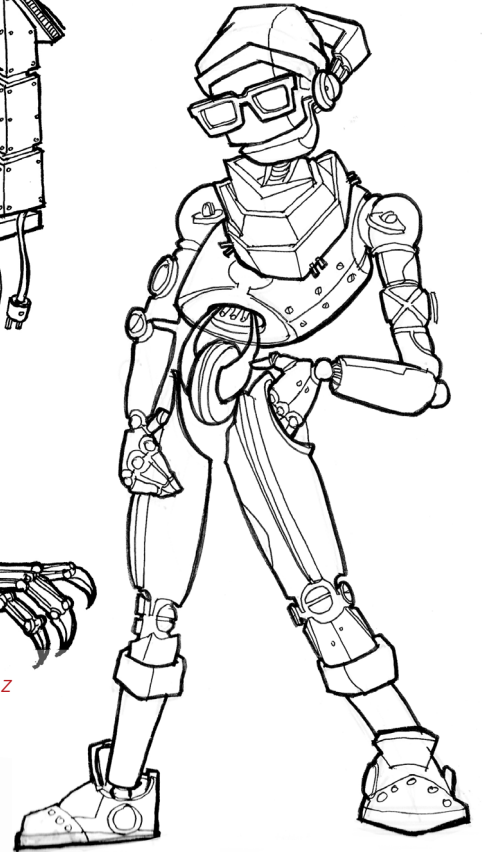

"HIPSTER" BY SAGE LATORRA

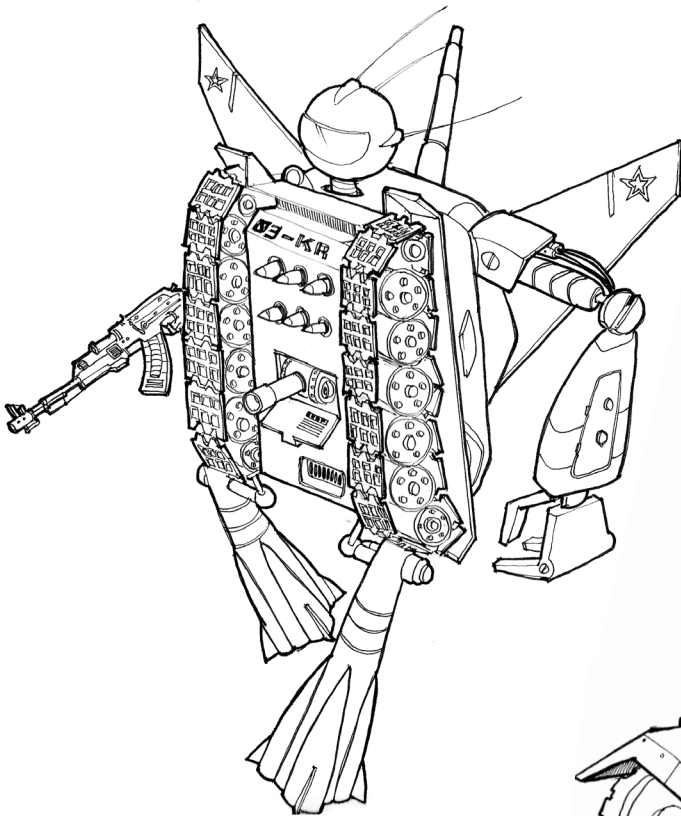

"S-347-T 'TOPE'" BY KAIRAM AHMED HAMDAN

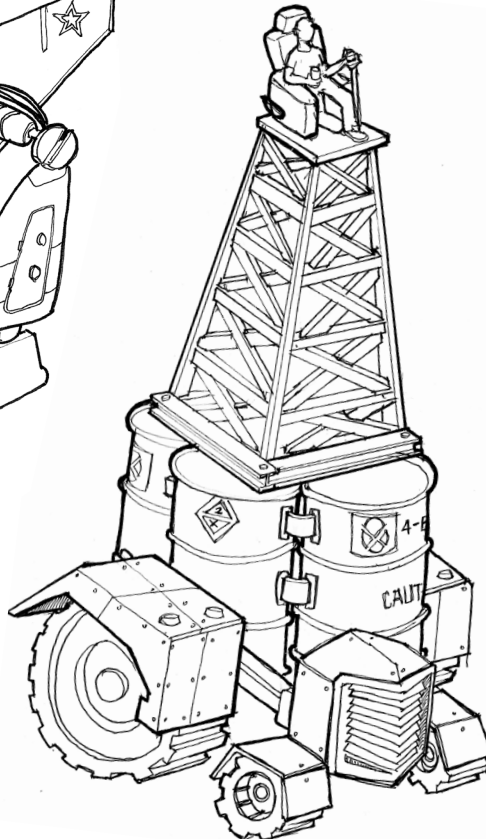

"TOWER" BY EBEN LOWE

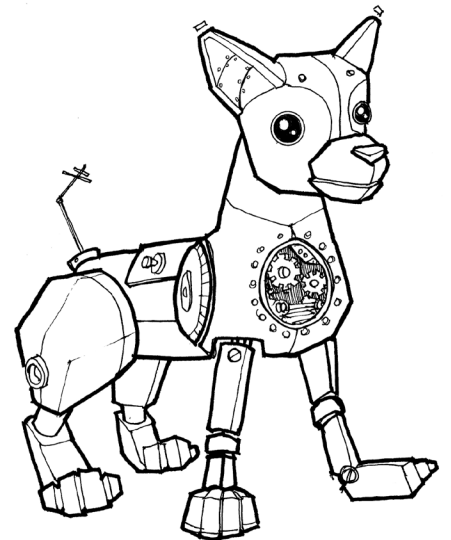

"YIP" BY CECI GOMEZ



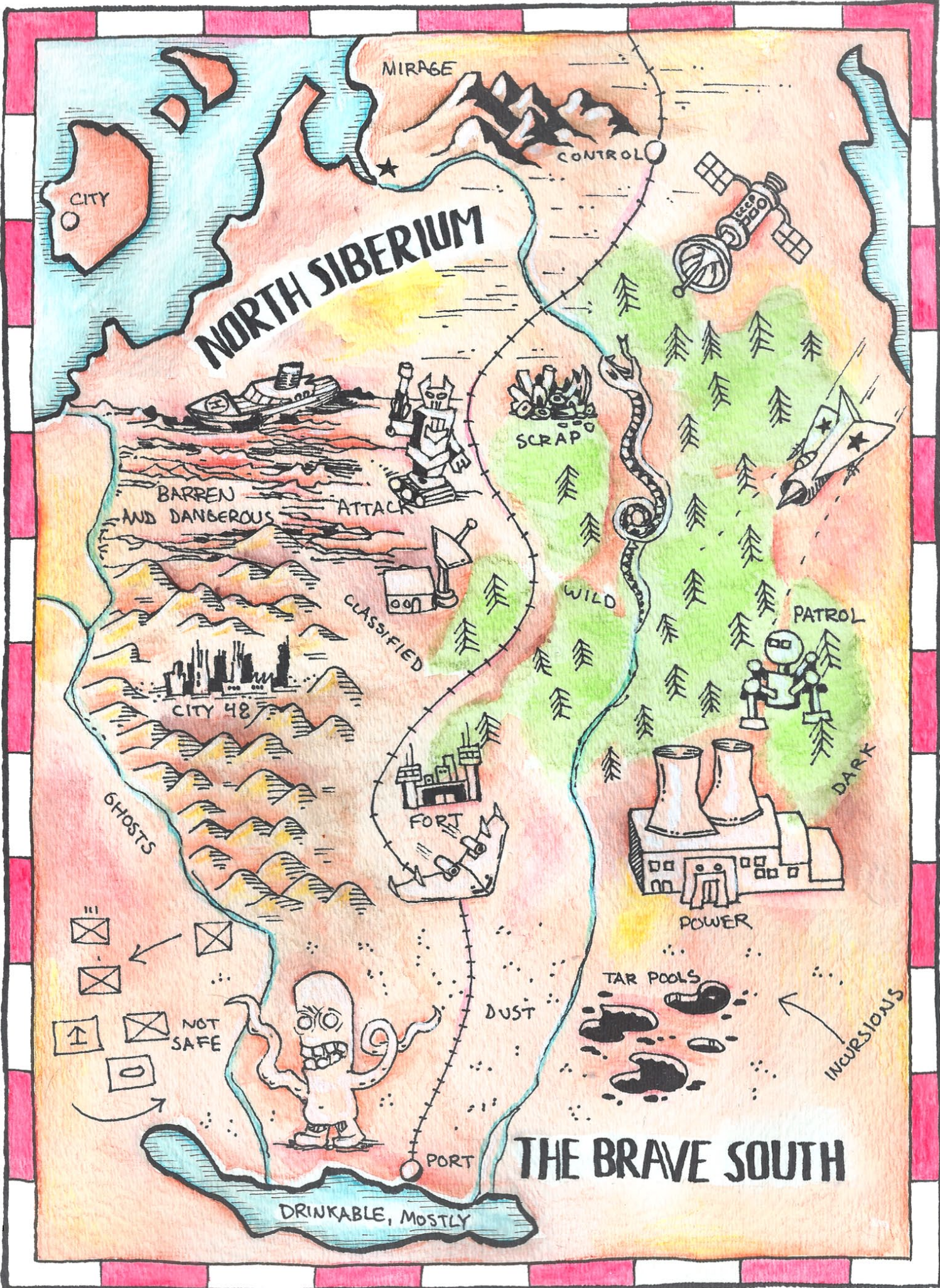

NORTH SIBERIUM

THE BRAVE SOUTH

MIRAGE

CONTROL

CITY

BARREN AND DANGEROUS

ATTACK

SCRAP

WILD

PATROL

DARK

CITY 48

FORT

POWER

TAR POOLS

INCURSIONS

DUST

PORT

GHOSTS

NOT SAFE

DRINKABLE, MOSTLY

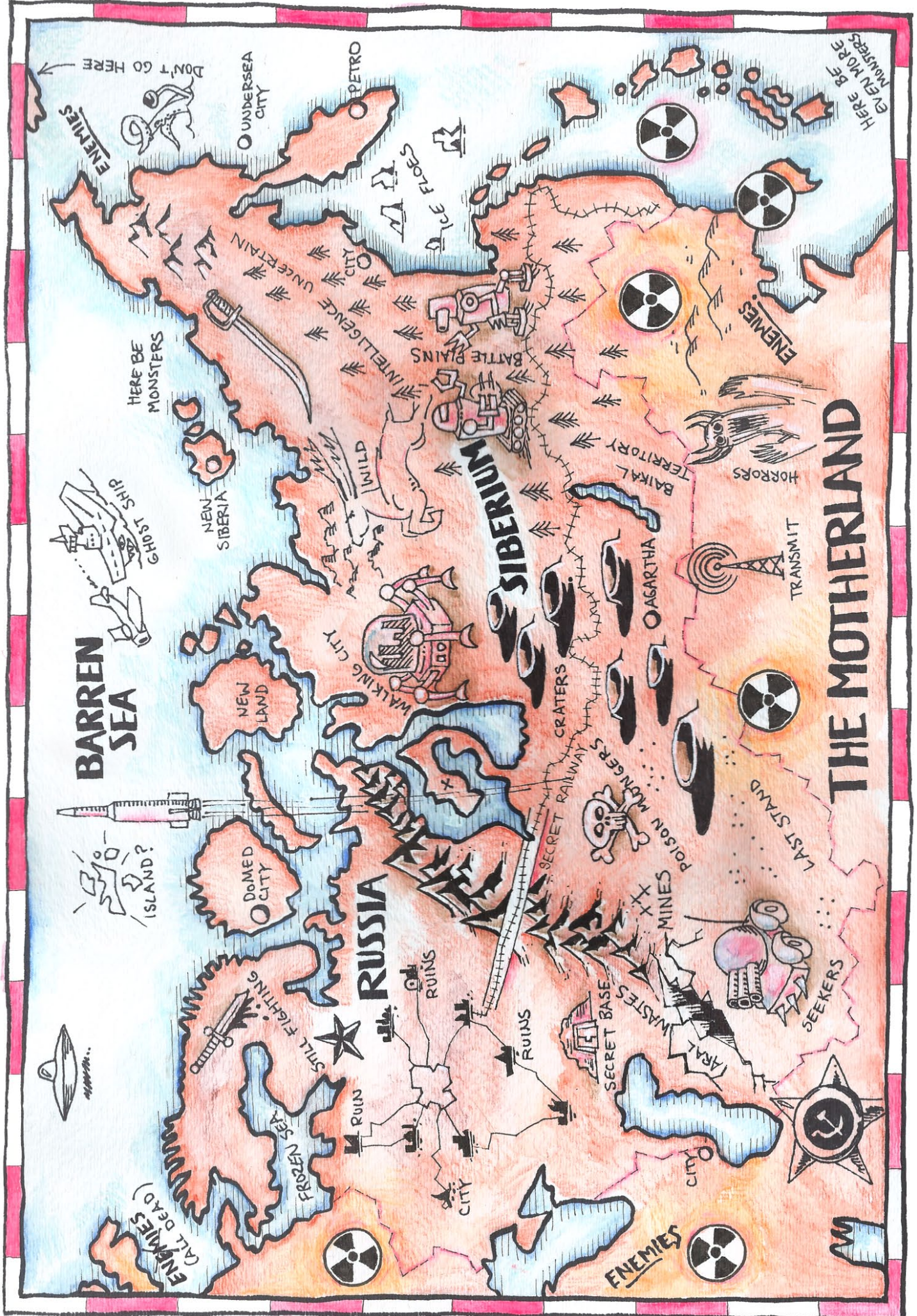

BARREN SEA

ISLAND?

HERE BE MONSTERS

GHOST SHIP

DON'T GO HERE

ENEMIES

UNDERSEA CITY

PETRO

ICE FLOES

WALKING CITY

INTELLIGENCE UNCERTAIN

BATTLE PLAINS

WILD

NEW LAND

SIBERIA

WALKING CITY

RUSSIA

RUINS

STILL FIGHTING

RUIN

FROZEN SEA

ENEMIES (CALL DEAD)

RUINS

CITY

SIBERIANUM

CRATERS

SECRET RAILWAY

POISON MONGERS

MINES

SECRET BASE

WASTES

BAIKAL

CITY

ENEMIES

BAIKAL TERRITORY

OAGARTHA

HARRIS HORRORS

TRANSMIT

LAST STAND

SEEKERS

SEEKERS

THE MOTHERLAND

HERE BE EVEN MORE ENEMIES

ENEMIES

VESNA THAW

ΥΦΟΥΣ ΣΦΜΜΟΝΙΤΥ



LEADERSHIP d4



STABILITY d4



TECHNOLOGY d4



ΠΟΡΥΛΑΤΙΟΝ d4

give your strongest aspect 3, your weakest 1, and the other two 2
when you roll the maximum number you can on a die, it's trouble! subtract a point from an aspect.

ΟΡΑΝ ΥΦΟΥΣ ΡΟΒΟΤ

ΥΦΟΥΣ ΝΑΜΕ:

ΥΦΟΥΣ ΣΑΛΛΣΙΟΝ:

draw (7 minus # of players) elements
each other player draws an element
assign 2d4, 2d6, 2d8 to your elements

you can add an appropriate Robot
die to your roll whenever you are in
your Robot during a scene

ΥΦΟΥΣ ΗΑΖΑΡΟΣ



ΥΦΟΥΣ ΣΕΝΕ ΤΡΑΚΚΣ

ΣΦΛΦΡΑ



success: check off lowest TN of another scene, OR fix a Robot element
failure: no effect

ΣΦΝΦΛΙΣΤ



success: add 1 to any Community Aspect
failure: subtract 1 from a Community Aspect that you risked on the roll

ΑΣΤΙΟΝ



success: add 1 to any Hazard on your sheet
failure: your opponent erases one check off of one of your scene tracks

declare what kind of scene you are in, and check off the lowest TN
to resolve something, roll 1d8 + community dice + hazard dice + robot dice
each die with a result lower than the highest checked TN is a success
when you check off TN6, go out in a blaze of glory at the end of the scene

initial Hazard scores: 3, 3, 2, 2, 1
describe each hazard
spend 1: + 1d10 to another players roll

Game Design and Layout by Nathan D. Paoletta.

Art by Amma Aning Odum.

Maps by Tony Dowler.

Thanks to Elizabeth A. McKeon for proofreading & editing, and to Joe Beason and Dylan Clayton for playtesting.

For more, visit <http://www.ndpdesign.com>

Please visit her at <http://www.nubiama.com>

Please visit him at <http://www.planet-thirteen.com>

DESIGNER NOTES

This game was designed “backwards” from a character sheet. The original sheet implied a more tongue-in-cheek game than I tend to design (including the line “In Soviet Russia, Character Sheet Design YOU” and having a “Facial Hair” field), and that certainly pushed me to take a less serious approach. I was inspired the most by the empty box in the middle of the sheet simply labeled “Draw Your Robot.” And so, the idea of post-Soviet post-Apocalyptic Robots was born.

I had recently completed publication of my Vietnam narrative game *carry. a game about war.*, which has a mechanism that tends to see characters do well at first, and then more poorly as the game goes on. On a mechanical level, I was interested in recasting the “death spiral” as a “success spiral,” in which your character will actually tend to do better as they gain their initial goals. Obviously, this can’t go on forever, and the “Blaze of Glory” idea came out of that investigation. It’s also inspired by the Transcendence mechanic in Clinton R. Nixon’s *The Shadow of Yesterday*.

This game was also my first fully-realized GMless game design. In the original draft, players pretty much have complete control over their scenes, with just the dice mechanic offering any opposition to them, and that in a simple pass/fail manner. I realized during the revision and playtesting process that this can lead to bland and tensionless play, so I modified the existing Hazard rules such that another player offers you a specific obstacle during each of your scenes. I’ve found that this adds enough “outside” opposition to give your Pilot’s struggle some meaning in the context of play.

The game is meant to play very quickly, with scenes only taking a couple of minutes each, especially at the beginning of the game. Each individual group will have a comfort zone for things like scene-setting, who gets to narrate what and how to deal with situations that aren’t squarely addressed by the rules. This game assumes that you’ll fill in these gaps yourselves, though I would encourage you to err on the side of short, punchy, and descriptive over proscriptive.

If in doubt, have a Robot Fight.

Thank you for your interest in Vesna Thaw! May your Robots always run smoothly.

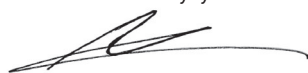

This game text is © 2012 Nathan D. Paoletta/ndpdesign. Icons modified from icons © DepositPhotos/Jana Guothova. Permission granted to reproduce anything you need to facilitate playing the game. Printed by MagCloud.

msrp \$5.00
ndp403