

ABERRANT

ELITES



Blood and fury for sale to the highest bidder

VENI, VIDI, VICI

Excerpt from narration given by Eleanor “Cloudburst” Shechter, former DeVries combat elite during the 2001 conflict in Nigeria. Annotated transcript from her interview in the PBS documentary video “Moral Warfare?: Combat Elites Talk About Their Experiences on the Front Lines,” aired on OpNet 2/13/12

“... It was a crazy war. We were moving down through southern Nigeria, along the border of the disputed territory; we were hitting enemy camps with just about zero warning every few days and hiding in a different ‘base camp,’ which was actually more like a ramshackle hut outside a tiny village, each night. The government didn’t have the resources to offer us more classy housing, and they seemed to figure that, since we were the hired mercenaries, we ought to be able to protect ourselves anyway.

“I can’t even begin to describe the whole situation to you — the heat, the dirt, the flies — I mean, it’s beautiful country but insanely poor. And the state of the people! That was what really broke your heart, what made you crazy.

“The villagers were all terrified because the resistance troops were hitting the border villages pretty much at random, sometimes with grenades, sometimes with open fire; sometimes they’d come and kidnap women, and the kids.... I can’t even talk about it. Farming had been disrupted all along the border, and there was no food in half these places. I mean, we got fed by our government employer, but have you ever tried to chow down and keep your spirits up for battle when you’re surrounded by starving people?

“The really heartbreaking thing, though, was that people kept coming to us and asking for our help. And we couldn’t help them. It was awful. I remember one evening in particular: We were being housed outside this little village near Calabar in the ‘disputed’ zone, preparing to go hit some falling-down little enemy fortification the next day. The group of us had been talking about what we could expect, and it just got more and more depressing. If no enemy novas turned out to be there, it was going to be just pitiful, all our firepower against this little wooden outpost; if there were novas there, we might find ourselves tossed on our asses. We could be heading into death within 24 hours, and we had no idea what to expect — our government contacts didn’t have sound info on it. ‘Military intelligence’ is an oxymoron. You’ve heard that joke, right? Well, it’s true. After a while we

got used to never having a clue what we were going to be doing from day to day.

“Anyway, it had just been a hellish day. We’d been shut up inside most of the afternoon to keep us out of sight, and we were twitchy as hell. Salvatore [Ferrante, AKA ‘The Venetian Blinder’ -OpNetAnno] was totally incapacitated with some kind of gastrointestinal bug he’d picked up in the last village, and Nikolas [‘Bastion’ Faloutsos, AKA ‘The Thunderer’ -ONA] had disappeared into the blue without his locator to look for the village whorehouse or something — strictly against orders, of course. We hadn’t seen him in nearly 24 hours; we had no idea whether he’d been kidnapped or ambushed or just defected or what. The tiny little fort-of-the-week was stifling, and the whole place reeked from Salvatore’s... well, yeah, I guess you maybe don’t want to hear that, not on public Op. But, you know, that really is how it was — stinking and nasty. If you think it’s bad when baselines get sick, you should try being around novas.

“So it was evening, and it was really hot, and there were all these flies, and our food was just terrible — I mean, we were eating this canned shit, some kind of meat stuff or something — and my nerves were just shot. Every footstep sounded like a thundercrack. And then, suddenly, we heard this knock on our door. When I looked outside I saw an entire sea of faces — it was a crowd of women from the village. The one guard we’d been given was making horrible faces and waving his gun at them. But I said, no, let them in. I figured that if we couldn’t protect *ourselves* against a group of village women, what the hell kind of mercenaries were we, after all?

“So I let them in, and there must have been 12 or 15 of them; all these women filing in and sitting down on the dirt floor of our crappy little ‘base’ and practically filling up the whole place. And one by one they started to talk to us. One of them knew English and a couple knew some French, that was how we talked, and they asked us to help them. Some of them had brought their children, see? They wanted us to help their kids. One woman had a little boy who’d lost half of his leg to a resistance grenade last month, and she begged me to heal him. Another one had a sick baby — God knows what was wrong with him, maybe a contaminated water supply — but he was so skinny, and his eyes were clouded over with cataracts, he was blind....

“Some of the others asked us if we could rig up some kind of force field to protect them after we had left. I guess they sort of knew about Nick’s force shield but didn’t really understand how it works. They were just begging us to ‘leave some of our help behind.’ I don’t know if they thought it was... well, some of them seemed to think that we had spirits, or something. Or that we were spirits — maybe this was an animism thing; I don’t know too much about the religions down there. We couldn’t really get them to explain what they were thinking.

“There was also another... there was this really young woman, and she had a tiny baby which she had brought with her. The girl had brought the baby with her while she was asleep, and she really was the cutest thing. She had soft little curly hair, big eyelids, little lips — the way you imagine perfect babies. So this young woman, this girl, she asked me, very softly: ‘Please take her with you. There’s nothing for her here, and she won’t grow up.’ This was her only baby, and she was really a young woman. She said, ‘We’re always running from bombs and bullets. I know she’ll grow up without a foot like Amadi’s baby or get sick and blind like Ifama’s.... And if she grows up at all, she’ll get captured and raped like my sister’s daughters.... Please take her with you back with you when you go home.’

“I swear to God, it was like in a fucking *movie*, you know, the tearjerker ones, but it was so fucking real I was practically crying. It was real.

“And we couldn’t say yes. We couldn’t help any of them. Do you know how awful that made me feel?

“One last girl talked to me just before the rest of them went. She was the one who knew English, and she took me and Kofi [Anansi, AKA ‘Clever Spider’ -ONA] aside just when the rest of them were leaving. She told us her name was Uchefuna — Kofi thought that was a funny name, but I remember it very clearly. She seemed to have her own agenda, and she spoke to us really quietly and intently, but when we listened to her, you know what she said?

“She said that the local people knew what the rest of the world didn’t: that this war was just a contest of wills between generals, but it was the people who were getting hurt. And she begged us not to destroy the fortification that we were going to destroy the next day. How did everybody know about that stuff if we were supposed to be undercover? I don’t know. The local people seemed to know a lot of stuff about what we were doing... sometimes it seemed they knew more than we did. Anyway, she made this little speech to us; she said: ‘My brother is fighting on the other side, maybe inside the fort. There’s no real difference between the sides. It is a war of artificial distinctions, drawn by generals who are hungry for power, not by the people of the tribes themselves. If you attack the fort, you won’t hit any of the generals who are really running the war, you’ll just kill the soldiers. They can’t help what they are doing.’ She told us her brother’s name. She showed us a goddamn

photograph! Where did she get a photograph, in a dirt-poor village like that? I think she was trying not to cry, but oh, God, she sure did want to convince us. I don’t know whether she was just trying to manipulate us. Maybe she was. But the look on her face, damn, I couldn’t have faked that....

“After they left, Kofi and Genny [Kofax, AKA ‘Fist of Doom’ -ONA] and I just kind of stood there and looked at each other. Salvatore finally came back from the outhouse, and then, all three of us stood around staring at each other. Just three all-powerful novas standing like idiots in this stinking little hut in rural Nigeria and feeling helpless because we couldn’t speak the local language and having absolutely no idea what we could do to help these people. I mean, what *could* we do for them? We couldn’t really heal their children; we didn’t have a healer among us. And even if we had, how could we have healed *all* those people? We couldn’t leave Nick’s force fields behind us, either, to protect them from the next army attack.

“Of course, there were things they were asking for which, maybe — just maybe — we could have done. Taking a baby home with us... not destroying a fort in the morning. Theoretically, that was within our power. But I couldn’t think of any way in which I could really make the decision to do that. I mean, in theory, maybe someone could decide to take that path. We were five of the most powerful people on the planet, after all — you’d think that a goddamn super-soldier would have the ability to choose — not to blow up a fort. You’d think that, wouldn’t you?

“I don’t know. Maybe I should have taken that path. I’ve thought about it a lot, about that night, since I came home. But at the time, all I could think was how fucking unprofessional of me that would be. Unprofessional....

“The next day we went to blow up the fort. What else could we do? It was our assignment, and we’re professionals to the end.

“There were two novas there, and they made things kind of hard — especially since Nick was still gone — but we took them out in the end; it was four against two. [Opposition novas Darvinder Rao, AKA ‘Avatar Nine,’ and Lilia Arakaki, AKA ‘Tsunami,’ both survived the encounter, although Rao was left visually incapacitated for nearly a month. -ONA]. And then we destroyed the fort.

“You know what the fucking thing turned out to be? An enemy water purification plant. Holy shit. That’s what Genny’s quantum bolts blew up. That’s what I threw the down the rain and whirlwinds for. That’s what Kofi spat his poison at: water.

“Well, that and six soldiers. I didn’t look too closely at their faces. I couldn’t get the image of Uchefuna’s photograph out of my mind. I have an eidetic memory, did I mention that? And did I mention that I haven’t been able to forget that photograph since then — or those women’s faces? Or that little girl’s hair?

“Fucking war....”

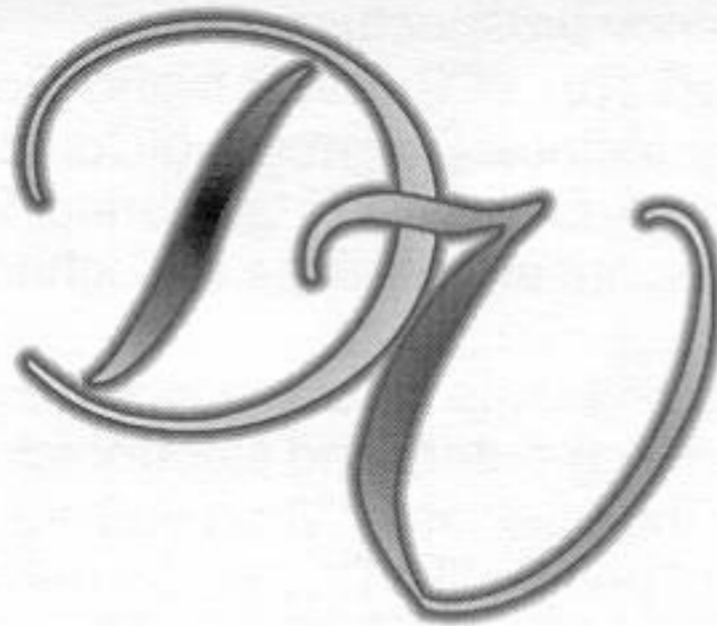

THE ELITE STANDARD

Welcome to the DeVries Home Page! The DeVries Agency is the premier contractor of nova talent in the world. With greater resources and a larger pool of novas than any other company, DeVries is the business to turn to when you need nova assistance for yourself, your business, your organization or your nation.

DeVries is particularly well known for those novas working in our private military company, DeVries National Tactical Solutions. Though not DeVries' only service by any means, DVNTS is the flagship of our corporation. DVNTS provides both nova elites to assist in government and corporate conflict as per international law, and provides full military backup for these novas. Nations can be assured that when hiring DeVries novas, they may also contract first-world military training for their officers and soldiers, full logistic and command support, advanced military hardware and our intelligence service. And of course, as you may see on the OpNet, DVNTS novas are, as we say, the Elite Standard.

DVNTS is also available for all other services provided by conventional armies. These include long-term policing, medical assistance, evacuation and natural disaster relief.

The DeVries Agency does not limit itself to just elite military novas, however! Through our general contracting business, DeVries International, interested parties may hire novas for almost any conceivable task. From financial consulting to lecture tours to art commissions to urban planning, DeVries will match your needs to the perfect nova for the job.

[COMPANY PROFILE, HISTORY, MISSION STATEMENT AND RESOURCES](#)

[SERVICES OFFERED BY DEVRIES NATIONAL TACTICAL SOLUTIONS](#)

[SERVICES OFFERED BY THE DEVRIES AGENCY](#)

[WORKING FOR DEVRIES](#)

[DEVRIES IN THE NEWS](#)

[CONTACT DEVRIES](#)

Excerpt from DeVries Agency prospectus:

Dr. Rachel Alinsky, Ph.D., Director of Research and Development

(B.S. Chemistry, Physics, Electrical Engineering/Computer Science; M.S. Materials Science, Mechanical Engineering, Chemical Engineering; Ph.D. Materials Science, Mechanical Engineering — Massachusetts Institute of Technology)

Dr. Alinsky is one of the crucial assets of our agency. Her unparalleled expertise in materials science, engineering, computers and electronics ensures that our elite operatives are the best equipped in the business. When you work with DeVries, it is because you can count on the support of people like Dr. Alinsky and her staff that you know you'll have that extra edge in any crisis.

An e-mail sent from frank_reneau@hudsontimber to john_hudson@hudsontimber on 05/01/07.

Mr. Hudson,

As you requested, I spoke with Mr. Penin at DVNTS about acquiring protection for our northwestern timberland in light of the recent eco-terrorist attacks. He offered to provide me with the same set-up that the agency has for the Nigerian oil fields: one or two novas, a fully staffed garrison with appropriate vehicles at each ten-mile point, a radio tower, an on-call baseline infantry unit, a specialist tracker with dogs, three helicopters, and munitions for all of the above. That seems a little excessive for Canada, but you know how much we've lost to these tree spikers. A smaller package, with cameras hooked up to remote satellite, might suit us better. Let me know what you think when you review the numbers.

Frank Reneau

Security Head, Hudson Timber

Excerpt from Newsweek, February 22, 1999

WINDHOEK, NAMIBIA Namibian government officials announced that novas working for a new mercenary company quelled last Wednesday's riots. The novas "Pursuer" and Anna DeVries, hired by DeBeers from the DeVries Agency to protect its mines from local terrorists, worked closely with the Namibian military to disband mobs around DeBeers property and in the capitol Windhoek.

The riots, which like others around the world followed the February 18 stock-market crash, caused relatively little damage. Pursuer and Ms. DeVries, along with DeVries infantry troops, separated the rioters into groups and, addressing them individually about the government's plan for the crisis, handed out relief supplies. While there were some casualties, the Namibian government is pronouncing the crisis "successfully handled."

The Namibian government, in gratitude to DeVries, has tentatively granted the company permission to set up its proposed base around DeBeers mines in the eastern highlands.

Criticism has followed the Namibian government's announcement. Commentators in the world media have said that by allowing the two nova mercenaries into its borders, Namibia is promoting a new kind of police state over its baseline populace. UN representative Saif al-Muhammed, speaking for the UN Security Council, said, "It is a shame that a government could so easily allow itself to be occupied by a mercenary army. With Team Tomorrow now available to aid nations in crisis, one wonders why Namibia would choose to ally with such a force."

Namibian president Paul Coulliwe, responding to the UN comment, replied, "DeBeers has always been a great employer of our people and a good friend of the government. If DeBeers chooses to hire DeVries to keep our countryside secure, it can only benefit us both."

THE DEVRIES AGENCY

Every time a new technology is developed, there is someone who exploits it first. If that corporate entity plans well, keeps its edge and works the new resource to the limit, it can become the industry leader — the name standard. And while elite novas aren't exactly a "technology" per se, nobody doubts the DeVries Agency is, as its motto proclaims, the elite standard.

DeVries supplies novas for every purpose, to every corner of the globe. Outside of Project Utopia, it is the largest private employer of novas in the world. The media tends to focus mostly on those novas — the masked elites — that DeVries hires out to fight in international conflicts, but those mercenaries are only the most famous of DeVries' nova employees. A nova plastic surgeon working with DeVries discreetly chin-tucks two aging baseline celebrities a week while a DeVries engineer consults for India's growing automotive industry. These individuals go unnoticed in the media because they lack the necessary degree of spectacle to warrant attention in the hyper-jaded media circus of 2011.

The DeVries Agency itself is the parent company of a larger organization, the DeVries Group. The best known of the DeVries companies, the agency hires novas for itself and for DeVries National Tactical Solutions, its separate mercenary company. Novas initially interact with the agency when they sign on to become part of DeVries. It's responsible for their payment, legal protection, training, health and benefits.

Clients contact either of the two companies when they want to hire novas, whether for military or non-military reasons. DVNTS is a private military company that contracts out novas and extensive support for combat, protection, or other related activities. The DeVries Agency is a more general resource company, which contracts out novas for everything from technical consulting to art installations. The agency also maintains a number of smaller businesses, like the *Pomme d'Or*, its infamous pleasure cruise ship.

The two companies are obviously very different, and the whole group has a complicated corporate structure. While it may seem confusing to outsiders, the management likes it that way. In particular, the group needs to keep DVNTS separate from its other companies. Most nations do not like mercenaries; they have a bad international reputation, despite the fact that even first-world governments have used them to supplement their armies

at times, e.g., in the Eastern European conflicts of the 1990s. Likewise, people who want to hire mercenaries look for the toughest and the best, the specialists. By keeping the two companies separate, DeVries keeps both of its reputations intact.

DeVries keeps its edge by offering the same comprehensive benefits and services for each company. The standard for both DVNTS and agency operatives is to exceed clients' expectations. Novas trained by DeVries are experienced, well prepared and come with everything necessary to complete their jobs. The price is high, but DeVries clients demand nothing less than the best. If DeVries does not have an appropriate nova on hand to carry out a particular mission at its standard levels of excellence, it will not accept the contract in question.

Corporate History

Anna DeVries founded the DeVries Agency in 1999, soon after her own eruption as a nova. An international business administrator in her own right, she had the good fortune to inherit her father's legacy: the remains of his business, Executive Actions, an infamous and highly successful mercenary company. By that time, large mercenary operations, while still uncommon, were becoming more prevalent. The US and other first-world governments had committed their forces to Bosnia and other parts of Eastern Europe and were reluctant to police the constant third-world land wars of Africa and Asia. The governments of these smaller countries became anxious to close the military gap left by the superpowers. They hired mercenary companies to train their own armies and even to fight rebel groups and nationalists within their own borders. The UN frowned upon these businesses. War-torn nations, though, regarded them as a necessary part of stabilizing their societies.

As a result of their increased role in world affairs, mercenary companies tried to convince others that their operations were legitimate. Anna's father, Holger DeVries, spoke before the UN on the benefits mercenaries could provide to countries that could not or would not call upon the First World for military aid. His facts were impressive: Executive Actions mercenaries in Sierra Leone had defeated revolutionaries and had been welcomed by the people of Sierra Leone. Some villages had even begged them to stay and bring order to the countryside. Executive Actions had also shown their expertise in an Angolan

civil war and kept the peace until free elections could be held in the capital. Holger DeVries noted that his soldiers, all veterans of Special Forces, stopped the rebel army, protected important diamond mines and out-performed the UN peacekeepers.

Nevertheless, Executive Actions came under fire by the media in the mid-90s for its role in curbing Bougainville rebels for the Papua New Guinea government. The rebels refused to allow access into the island's copper mines, which had been purchased by an Australian mining company from the New Guinea government. Executive Actions was seen as the enforcer for an oppressive, exploitative regime. Holger DeVries eventually withdrew his company from the conflict — losing a small fortune in the process — rather than face UN sanction and ruin his otherwise good name. The company disbanded in 1995, and Holger retired to his Cape Town estate.

The family held onto the company's resources, though. When Anna DeVries came up with the idea of a freelance agency for novas, she already had a training facility outside of Pretoria ready to re-occupy, complete with a small air force of American Puma, French Alouette and Russian Mi-17 helicopters, Mi-24 Hind gunships, MiG-23 jet fighter-bombers, a squadron of Swiss Pilatus training planes and two Boeing 727s. She contacted her father's chief tactical and administrative assistant, former British general Frank Carrington, and began assembling a number of South African, American and British officers to staff her new company.

Although she had an impressive baseline administration with military experience, Anna knew she would have to gain significant capital to be able to hire novas with combat backgrounds. That capital came from diamond giant DeBeers. DeBeers, which had controlled portions of Africa for decades, wanted to make sure those areas did not need disaster relief — and scrutiny — from the newly formed Team Tomorrow. Hiring freelance novas from Anna DeVries seemed like the best way of calming DeBeers' mining territories and avoiding Project Utopia's intervention.

Following the successful handling of the riots in Namibia, the DeVries Agency began extensive recruiting. Initially, much of this recruiting took place around Rashoud facilities, attracting novas trained by Project Utopia but uninterested in the Project long-term. Anna, trained at the London Rashoud facility, used her connections there to hire several sympathetic novas to recruit further, much like companies recruit at universities.

At first, Project Utopia was opposed to this recruitment. But as it became obvious that not all novas had the desire or the disposition to work with Utopia, they tacitly accepted the role of DeVries as a company with the financial support to give novas the employment and benefits they needed. From the beginning, DeVries offered novas generous insurance and retirement plans, paid time for training both at Rashoud facilities and with the agency, paid bonuses for attracting new clients, and offered numerous other perks. It also offered novas paid

maternity and paternity leave, as well as high-quality day-care vouchers and accommodations for nova parents.

The DeVries Agency advertised these benefits to nova recruits in an aggressive worldwide media campaign. Taking out large advertisements on the OpNet and in the world's major newspapers, DeVries billed itself as something new: a company by novas, for novas. Anna herself appeared in these ads endorsing the bold new sub-culture her company promoted. DeVries novas might work for baselines, but they keep their own identities and politics. They were the best, the elite. Many young novas found the prospect tantalizing.

The DeVries "corporate culture" served to attract novas to the company. It provided an alternative to the life offered by Utopia. The agency converted the old Executive Actions base outside of Pretoria into a full training facility, with luxury housing for novas who chose to live close to the corporate headquarters. Many didn't, returning to their native countries or to the country where they would be working, after signing their contracts. But all the novas who signed on to work with DeVries got to experience the culture: working hard by day, training vigorously against each other, going on expeditions into the jungles or the savannas together, and partying all night. Novas who chose to work as masked Elites were given a masking ceremony by the company before leaving to perform their first contract. Most emerged from the experience with a sense of identity as an Elite, proud to wear the mask and work for themselves through DeVries.

Even cynical novas generally retained their friends and their contacts in the company. DeVries developed a reputation for reliability among both its novas and its clients. Not only did it pay well, but DeVries never lets its Elites go out on assignment without sufficient information and backup, even if that means hiring another nova or another company to get the information needed, and its employees took notice, particularly in light of the seemingly uncaring treatment received by many of the novas who worked for Project Utopia.

In 2001, the DeVries Agency achieved one of its major recruitment goals and began hiring nova doctors and former Rashoud facility staff. Setting them up in a laboratory and training center in the expanded Pretoria base, the DeVries Agency began recruiting newly erupted novas in January 2002. This allowed them to become major competitors with Project Utopia in hiring new novas. Massive recruitment of non-combatative novas soon followed, and DeVries expanded its corporate definition of "Elite" to any highly trained nova-for-hire.

This recruitment of novas in the media, medical, business and other consultant fields came at a good time for the company. DeVries needed to improve its image in world affairs. It had hired out extensively during the Equatorial Wars of May–November of 2001. The governments of Niger and the Sudan, impressed with DeVries' work in Angola and Namibia, had contracted almost 15 mercenary elites from DeVries, paying for them with controlling stock

ABERRANT

in Nigerois oil fields, another DeVries-protected site. While DeVries Elites would not fight each other to the death, they were used against other elites and military targets. The resulting civilian deaths numbered in the hundreds. The UN charged several DeVries Elites with war crimes but dropped the charges after negotiations with DeVries lawyers and a coalition of African governments.

In 2001, nations began to fight their minor wars through elite proxies. DeVries, as the company with the most, and best, elites for hire, continued to contract out novas to the governments of African nations, as well as India and Pakistan. Most of DeVries' work in the Kashmir conflict comes from Pakistan, where it competes intensively with Rashid bin Muhammed Al-Nasir's Janissaries. DeVries has been quick to publicize the advantages of having nova champions fight each other instead of engaging in conventional warfare. With its clients, however, DeVries points out the disadvantages of such modes of combat: a spectacular nova battle, though it gets the ratings, still does not occupy territory the way reinforced nova occupation can.

Despite the international and media popularity of elite proxy combat, the DeVries name was tarnished by its extreme involvement in messy, long-term warfare. In December of 2001, DeVries publicly announced the formation of DeVries National Tactical Solutions. While refraining from apologizing for the actions of its elites in the Equatorial Wars, the agency announced it would no longer represent combat elites. All such elites have since been man-

aged by DVNTS. Although the DeVries Agency still trained its masked mercenaries, the corporate split allowed DeVries to maintain its base in South Africa, which the Mandelan government had threatened to remove. DVNTS set up its own, smaller base in Namibia, where the Elites conduct their most intensive combat training.

In the meantime, DeVries heavy recruitment of non-combatant novas took off. The agency began its most lucrative contract to date in 2002, hiring out a nova research team to mining giant Mineral Reserves, Inc. to explore the collection of mineral wealth in hard-to-reach undersea locations. Utopia had already done so for manganese, but other potential resources were vast and located either in international waters or in areas controlled by nations ready to negotiate. When the team discovered and patented a method of extracting iron, cobalt, nickel, copper and other metals from sediments on the Pacific floor, DeVries' value skyrocketed. It purchased Mineral Reserves and began harvesting the minerals with the help of novas immune to suffocation and deep-sea pressures. Like Project Utopia, DeVries also found in its undersea mining the perfect employment for its more unusual looking novas, out of the public eye.

DeVries now has the capital to sign on nearly any nova interested in elite work and a reputation for excellence in several fields. DeVries has steadily built on this reputation to attract novas from a wider and wider array of professions. Most recently, it has begun to attract

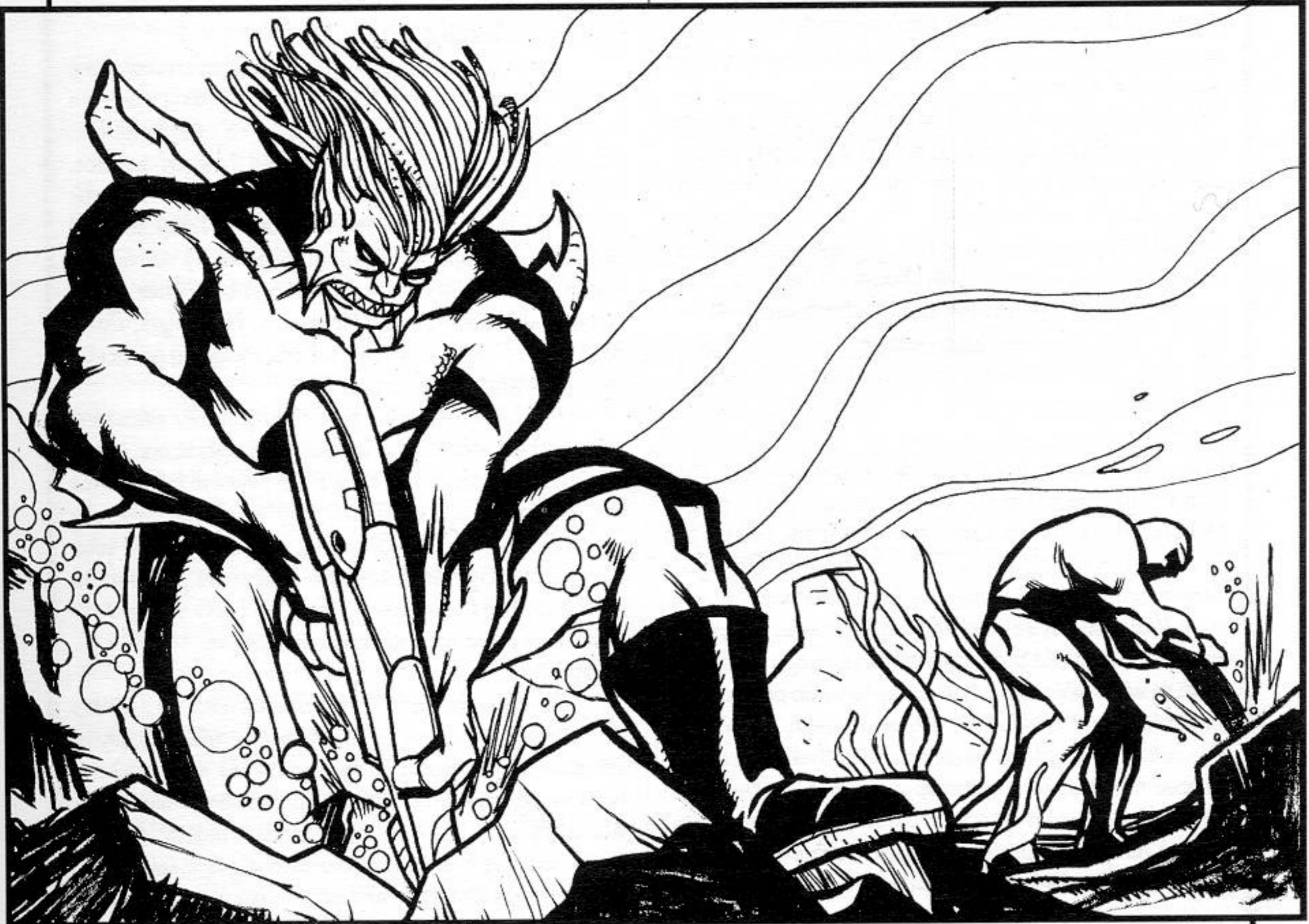

artists and intellectuals with promises of large grants and complete intellectual freedom, and it has considered endowing an African university.

Major Clients

The DeVries Agency has a vast client list, including many nations and multi-billion dollar corporations, along with various private individuals able to afford the company's fees. That list is far too long to cover in detail; DeVries' customer database takes up gigabytes of information many companies would kill to get their hands on (and some have tried). This section highlights some of DeVries' most important clients.

Governments

Many national governments and local municipalities employ DeVries Elites. Most often, governments work with DVNTS, hiring mercenary elites for military operations, either covert or overt. Governments also employ DeVries agents for security and intelligence work. Only rarely do governments turn to DeVries for nova assistance in technological, political or social matters. For these things, most governments turn to Project Utopia, although some prefer the autonomy and discretion DeVries offers.

The United States of America

Yes, Virginia, the CIA really does finance world conflict. DeVries is well aware that money flowed into Sierra Leone and other nations from well disguised American sources enabling them to hire more novas during the Equatorial Wars. DeVries made a significant amount of money in fees as well as for keeping quiet about what it knew.

But that's only a small part of DeVries' close relationship with the United States. The US military frequently hires DeVries' agents for surveying, engineering consulting and espionage. The US has particularly found DeVries' corporate espionage and sabotage service of great assistance. With Utopia's Science & Technology department seizing new technologies left and right, spying on research labs has become a race against the clock, and DeVries has all sorts of contacts (and clients) in various technological fields. Ideally, DeVries agents copy new research then sabotage the facilities before Utopia can get its hands on the goods. It then sells its findings to the US for enormous sums of money. DeVries then gets a second profit from selling the blacktech on the black market or charges the US higher fees if it insists on exclusive access to the data.

Well known for criticizing Utopia's "abuse of power," the United States government keeps most of its dealing with DeVries quiet in order to avoid public backlash. Many factions within the government, particularly the military, would still prefer to have their own novas, instead of relying on mercenary agencies like DeVries.

Africa

A number of African nations, notably Niger and the Sudan, employ DeVries Elites on a fairly regular basis.

Elites have become the standard means of fighting the various brush wars and border conflicts that spring up between African nations on a regular basis. Rather than fielding armies, countries with issues to settle hire elites capable of doing the same damage as a regiment, but with far greater mobility and impact. Of course, that only leads the other side to hire elites of its own. Other DeVries clients (corporations and other governments like the United States) help fan the flames of many conflicts and throw money and resources behind one side or the other (or, sometimes, both). DeVries operates in the middle, graciously taking money from all sides.

DeVries Elites often work on retainer for African nations like Niger, to help guard vital resources against attack and to provide border patrols and surveillance equipment (or novas with the equivalent abilities). Sierra Leone has been a DeVries client from the very beginning, a legacy from Anna DeVries' father. One of the few African nations not employing DeVries in one way or another is Nigeria. President Sango has stated that he will not support a company "that grows fat on the blood of this continent" when Nigeria can recruit and train its own novas.

More than anywhere else, DeVries contracts in Africa are often subsidized by, or in cooperation with, various corporations with interests (primarily mining) in the area. For example, DeVries' arrangement with the government of Namibia is through the DeBeers Corporation, although the government supports the presence of DeVries personnel in their country.

Central and South America

Many Central and South American governments are regular employers of elites, either defending against a border conflict or outright invasion or else looking to cause problems for a neighbor to keep them off-balance, or even prepare them for a coup. (Most rebel groups can't afford DeVries, but other national governments and corporations supporting them often can.) At various points, DeVries has worked for Argentina, Chile, Paraguay, Belize, Guatemala, Honduras, Nicaragua, Costa Rica, Venezuela and several others, including particular factions within those nations.

DeVries activities in Central and South America tend to be more sporadic and briefer than operations in Africa, usually contracted on a case-by-case basis. Once the mission is accomplished, the employer generally wants the DeVries personnel out of the country as soon as possible. Operations in the region are well known among DeVries employees for being fairly straightforward: Go in, get the job done, and get out.

Pakistan

The government of Pakistan maintains a relationship with DeVries primarily to maintain a constant supply of elites for their ongoing conflict with India and protection from novas from other nations, particularly China. Pakistan is relatively nova-poor compared to nearby India and China, making the nation feel all the more vulnerable. DeVries helps shore up Pakistan's security with a standing

garrison of security personnel and advisors assisting the Pakistani military. Nova conflicts in and around Kashmir have involved DeVries Elites, as well as Team Tomorrow personnel and novas from India and China.

The presence of DeVries Elites in Pakistan is one of the sticking points impeding peace negotiations in the region. Pakistan refuses to dismiss DeVries, fearing an attack, and DeVries maintains its legal right to fulfill its contractual obligations to its client, despite strong-arm tactics from Utopia trying to get the company to withdraw from the area. Nobody is willing to give an inch in the negotiations, making it likely DeVries will remain a presence in the region for a long time to come.

Natural Resource Companies

Unfortunately, a large percentage of the world's wealth is found in politically unstable areas. Corporations need to go to great lengths to defend their valuable investments from rebels, patriots and, occasionally, from the governments of their territories. DeVries' first client, DeBeers, belongs to this category, as does ExxonMobil and a number of petroleum, mining and forestry firms.

Typically, these businesses hire DeVries Elites to protect their operations, either through guarding important sites or by creating conflict elsewhere. Although the Equatorial Wars were, in theory, funded by various African nations (and the CIA), a large part of DeVries' revenue during that conflict came from corporations. They paid DeVries to conduct battles away from their mines and oil wells, to destroy their competitors' assets and to neutralize protesting sections of the local populations. Some companies, such as DeBeers, even use elite warfare as an excuse to drive up prices.

These companies also contract DeVries agents for more peaceful activities. Novas are of great help in finding new mines or oil reserves. They can also explore dangerous areas and locate undersea mineral deposits far more affordably than heavy machinery and large survey teams.

DeBeers

One of DeVries' first clients, DeBeers controls extensive diamond mines throughout Africa, particularly in South Africa and Namibia. As the company slogan says "a diamond is forever," and while diamonds may be, African regimes are not. Governments have a disturbing tendency to rise and fall with the shifting of the political winds, and such vicissitudes are, more often than not, bad for business. DeBeers employs DeVries Elites (on retainer) to ensure security for their major facilities in case of rebel uprisings, terrorist activities or even government attempts to nationalize vital industries and resources, all of which have happened in recent memory. For its part, DeVries has gained DeBeers' complete trust for their swift and decisive actions, which have saved the company millions, making the high fees they pay DeVries more than palatable.

The company has been known to employ elites in various operations intended to destabilize particular regions where DeBeers requires trouble, either to damage

competitors or to convince local authorities of the need for a more stable economy, of the sort the company can provide. This has also proven a profitable tactic, although it's becoming less so now that other nations and corporations are hiring elites of their own, particularly the Janissaries and Peacekeepers, Inc.

A recent wrinkle in the DeBeers-DeVries relationship comes from DeVries' expansion into undersea mining operations. DeBeers has hired several nova consultants to help develop new mining techniques. It has also started employing novas to locate new sources of diamonds and gold for potential mining, with a portion of the profits from the new mines going directly to DeVries (which pays a regular fee to the nova agent).

ExxonMobil

The embattled world petroleum giant ExxonMobil regularly employs DeVries Elites and personnel to ensure the security of its drilling, refining and pipeline facilities around the world. The corporation is acutely aware of the damage a nova is capable of doing to its operations, and the threat of nova eco-terrorists such as Greenwar and Sea Force alone is sufficient for it to justify the added security. Add to that problems with local governments, political uprisings, baseline protests and eco-terrorism, and the company's investment in elites is well worth the money spent. DeVries has ensured the security of vital oil-drilling sites and kept other problems to a minimum.

The presence of novas has had other benefits as well. In 2003, an accident at a drilling site in the North Sea resulted in a fire that would have destroyed the site and led to an ecological catastrophe, had the DeVries novas on site not used their abilities to contain the fire and prevent thousands of gallons of crude oil from spilling into the water. ExxonMobil points to incidents like these, along with their cooperation with Project Utopia's environmental projects, as proof of responsible corporate citizenship.

Since the invention of the hypercombustion engine nearly halved the world demand for petroleum, oil companies have been forced to diversify to remain competitive in the world market. Like DeBeers, ExxonMobil has taken a strong interest in DeVries' new underwater mining techniques, employing novas as researchers into new ways to locate and extract oil and other natural resources.

Other Corporations

Many other corporations employ DeVries agents for everything from security to public relations. The list is extensive and includes many Fortune 100 companies like ViaSoft, AT&T, Time-Warner, Beatrice, Nestlé, Disney-Apple and many, many others. Some of the typical jobs corporate clients need done include:

- **Security:** Corporations all have assets they want protected, against rival companies, criminals, terrorists and so forth. In some cases, a company's operations may be controversial or even quasi-legal and in need of additional

protection. Many corporations employ elites to protect lumber harvesting projects in South America, for example, to ensure new grazing and farming land to produce the raw materials those companies need for fiscal well-being. Other companies have elites to protect important research facilities, to secure confidential information and to perform similar tasks.

- **Research & Development:** The abilities of many novas are useful in the development of new products and strategies, and companies hire DeVries agents to supplement their own R&D departments (which may or may not already have nova employees). Such research contracts are generally worked out to give the researcher and DeVries a cut of any profits resulting from the research.

- **Public Relations:** Corporations use novas in a wide range of public relations areas, particularly as spokespersons for their products or services. DeVries' elites serve as spokespersons for various products, particularly for companies looking for the edgy, exciting feel offered by a known military elite like Pursuer. They also perform public relations stunts ranging from skywriting the company's logo high above a city in glowing energy to attending charity events intended to promote the company's latest products.

- **Industrial Espionage:** Companies often find uses for novas in gathering information on rival corporations. This may be as simple as a market analysis by a nova able to grasp the intricacies of free-market economics more easily than any baseline or as involved as an espionage mission to steal information and/or prototypes from a rival. Such operations are nearly always covert and involve overcoming the rival company's security, which may include nova consultants and security agents.

Private Individuals

There are not many individual citizens wealthy enough to afford the fees DeVries charges for its services, but there are more millionaires in the world than ever before, and those with means are often willing to pay any price for the unique services that DeVries offers.

The two most common "private" jobs for elite novas are security and "companionship." The first is much like a corporate or government security job but on a smaller scale. Some of the wealthy are more than willing to shell out the money to have a nova bodyguard at their beck and call. This is often as much for the status of having a nova bodyguard as it is the added protection, although that is also a factor. Many of these employers are novas themselves with abilities such as Mega-Intelligence or Mega-Appearance; while their quantum abilities have brought them great wealth and fame, they lack strong defensive or offensive abilities, putting them in need of a physically powerful nova to watch their backs. The rest are baseline celebrities and wealth individuals.

The other reason individuals seek to hire novas is often simply to have the chance to associate with one of the "beautiful people" of the 21st century. DeVries runs a discrete "escort service" through which a client can hire a beau-

tiful and engaging nova companion for a night out on the town, a visit to the Oscars, the Cannes Film Festival or an ambassadorial dinner. These nova "companions" invariably have Mega-Social abilities, making them the life of the party. A single evening can easily run into five or six figures. Although they don't publicize it, DeVries also arranges sexual services for clients willing to pay for the intimate attentions of a Mega-Attractive nova. Fees for sexual services range from merely exorbitant (in the case of a simple "date with sex") to several million dollars for more extreme fetishistic scenarios. DeVries is willing to arrange any consensual act, though what actually goes on depends wholly on the nova and the client's particular tastes.

Corporate Policy Hiring

DeVries has a simple hiring policy: "There are no useless novas, but some are more valuable than others." The agency always seeks to increase the number of novas it represents and, despite the agonizing paperwork, novas find it fairly easy to get a contract with DeVries.

Getting steady, high-paying work is another matter. DeVries takes anywhere from 10 to 80 percent off the price of every job an agent undertakes, and consequently, it pushes its highest-powered and highest-priced novas whenever possible. These are the people DeVries advertises most extensively; a publicity agent is sure to call N! every time Lance "Stone Badass" Stryker or Totentanz goes into battle. Less experienced novas and those with less impressive powers may be called on a more infrequent basis; there just isn't as much work for them. Still, a nova may expect an assignment with DeVries within a month of signing on, and the pay is usually worth the wait.

The quickest way to sign on with DeVries is to go to one of its corporate offices in New York City, Pretoria, Amsterdam, San Francisco, Rio de Janeiro, Sydney, Bangkok or Cairo. However, DeVries recruiters are always on the lookout and often approach newly erupted novas with contract already in hand. Novas in remote locations can expect transportation to the nearest corporate office after making initial contact. DeVries also keeps at least one recruiting officer on retainer near every major Rashoud facility, especially those in first-world countries where novas are more likely to explore every employment option, rather than simply signing on with Utopia.

Recruitment officers are always personable, well groomed and dressed to make an impression. Though usually baselines, they are sure to stress the freedom a nova is given when working with DeVries — they may accept or refuse any contract, their politics are their own, and DeVries will never monitor them in their off time. Working for DeVries, they are told, is working for yourself... except they never have to look elsewhere for training, advertise their skills, handle their own finances or find their own legal counsel. They get all the benefits of working freelance without the headaches.

Novas may sign a number of different types of contracts with DeVries. The most common contract used with established novas is a simple freelance contract. Under this sort of contract, the nova is contacted whenever appropriate work becomes available. He may sign on with other agencies or represent himself as he pleases. If he wishes to train in the DeVries training facilities or take advantage of other benefits, those expenses are drawn out of his assignment fees on a case-by-case basis — hence the 10 to 80 percent figure. If he wants an assignment in the near future, he can call DeVries, and it will put his name in a priority pool when new assignments come in. This is not unlike working for a nova “temp agency.” Novas with freelance contracts can (and do) sign up with other agencies and make their own arrangements as well.

Inexperienced novas usually obtain a different type of contract with DeVries from that seen by veteran Elites. They represent a significant investment for the company, which may need to train and support them for well over a year before seeing any return on investment. They are generally offered a two- to five-year employment contract, after which they may renegotiate. The novas live for that period at the training facilities in Pretoria or Windhoek, depending on whether they will ultimately work for DeVries, DVNTS or one of the subsidiaries. During this time, they receive training in the use of their powers, in linguistics and in any skills or knowledges that may be useful in their future fields. DeVries may finance their education at a university, conducting quantum training on weekends or between semesters. DeVries also provides them with full medical care and assumes legal responsibility for their actions. In return, recruits work exclusively for DeVries for the duration of their contract. In addition, DeVries takes a flat 50 percent fee from every assignment the nova undertakes during that period. These assignments, even during training, are usually frequent, if minor. The agency does its best to expose clients to its new novas and makes the training worth the while of both DeVries and its recruit. During this training period, DeVries gives its new elites a limit on how many assignments they can refuse without invalidating their contracts.

DeVries’ highest-end novas (those with five dots in the Backing Background with DeVries) receive a third sort of contract. As inexperienced novas do, they sign exclusivity agreements. However, they receive much more extensive benefits, up to and including vouchers and grants for their extended family, a huge line of credit and use of DeVries’ assets, from one of the company jets to prototype weapons to corporate penthouses and resorts. This is despite the fact that DeVries rarely takes more than 10 to 30 percent off their assignment fees. DeVries doesn’t need to. When ViaSoft, ExxonMobil or the US government is bidding for a nova’s services, a smaller management fee is still substantial.



Most importantly, though, DeVries promises unparalleled care and protection for the nova. This is not a minor benefit: Anna DeVries is quite serious when she tells novas her company is prepared to meet their needs. If a nova is hunted by a nation, the UN, a company or even Project Utopia, DeVries will arrange for her legal defense or hide her from the world to the limit of its ability. If a nova is overcome by taint, DeVries will find her jobs where her aberrations are moot and give her extended treatment by paraphysicians. And if a nova becomes permanently disabled on assignment, DeVries will cover her retirement indefinitely — even if she is projected to survive for 100 years or more. A nova under these agreements must make publicity appearances at DeVries' request. Also, because of these perks, the nova has an obligation to perform a certain number of jobs a year. She may not reject jobs for trivial reasons, and a refusal is usually followed by an interview with Anna herself.

Transcript of an interview between Regina Barrone and Kyle Scott, 03/06/06

RB: Welcome, Kyle. I'm Gina... pleased to meet you.

KS: Hey.

RB: I'm so glad you came into the office. Is this your first time in New York?

KS: Yeah. It's kind of intimidating. I'm glad I came here by popping. I'm from Kennisaw; that's in Georgia.

RB: So my receptionist told me! You made quite an impression, appearing in the building like that. Do you have any other powers besides teleportation?

KS: Yeah, I think so. I mean, I keep hearing all these radio stations in my head, even when I try to tune them out. It could be really cool, except that most commercial radio sucks.

RB: Well, I suppose we should get right to the point. We can help you with that. In fact, we can help you develop and control all your powers and make you a very rich man in the process.

KS: I know. That's why I came here instead of going to PU. Y'all pay a lot better.

RB: (laughs) We do have that reputation. But maybe you don't know just what else we can offer you. I'd like to show you our contracts and talk to you a little about how we do our business.

KS: Okay, but one thing... I want to wear a mask. I don't want everybody to see my whole life on the OpNet, you know?

RB: Don't worry! Just as soon as we come to an agreement, I can send you off to Superimpose. They do a great job there helping you construct an alternate identity, a costume, everything you need, if that's what you want.

KS: Cool.

Letter sent to Lotus Infinite from Anna DeVries, 01/20/08

Dear Linda,

Hello! I trust you enjoyed your ascent of Machu Picchu, and that the Peruvian hospitality is to your satisfaction. I hiked parts of the Andes myself 10 years ago; the air there is truly amazing. Please be sure to drink some maté and think of us here in South Africa.

Mr. Temenke tells me that you still aren't sure about accepting a full-time contract with us. As your employer and long-term champion, I would like you to consider our offer carefully. While the constant movement of your hair is both lovely and dramatic, I understand the worries it may cause you. Novas who experience such effects often proceed to less delightful ones, and we at DeVries would like to help you with whatever care you require, both now and in the future. I understand you have been to visit our paraphysicians in Amsterdam, so I know my plea does not fall on uninterested ears.

Linda, you have always been a major asset to both our company and the reputation of novas at large, and I know that over 90 percent of your work is through our agency. Please allow us to cement our relationship in a way that will benefit us both. I would be happy to discuss the extensive privileges and benefits we can offer you at any time in the near future. All you have to do is ask.

Regards,
Anna DeVries

Working for DeVries

DeVries takes the training and work of its nova agents very seriously, it has to; its novas represent DeVries in the public eye and to the company's many clients. People expect only the best from DeVries, and the company does everything it can to ensure its novas live up to that expectation.

Education and Quantum Training

Anna DeVries believes the key to having the best nova elites in the world is constant training to help her novas improve their abilities and develop new ones. She also stresses the importance of education and training in the various skills they need to carry out their assign-

ments. Carrington is in complete agreement; he believes the nova training program is one of the most vital elements of DeVries' success. Not only does successful training make elites more effective, it also offers a lure to newly erupted novas deciding what to do with their abilities. It offers an alternative to training at Utopia's Rashoud facilities, something some novas have become leery of since certain rumors have popped up about Utopia's unethical practices.

DeVries takes a two-pronged approach to training its agents: The nova is taught fine control over his or her quantum abilities, and when not honing powers, the agent received education and training in more mundane — but no less important — matters like strategic operations, technology, geography, politics, business and so forth. The first applies only to novas, but the second applies to all DeVries personnel. Anna prides herself on the fact that even the secretaries have tactical training.

Quantum training takes place in one of two places, the DeVries compound in Pretoria, South Africa, or the DVNTS base in Namibia, depending on which branch of the company the nova is associated with. Military elites train at the more Spartan DVNTS base, while all other novas generally train at the DeVries compound, which is quite luxurious. Both facilities are staffed with paraphysicians and experienced researchers, many of them recruited from Utopia's Rashoud facilities, much to the Project's dismay.

These personnel begin by testing new nova recruits to determine as much as possible about their abilities.

These tests also help DeVries decide what sorts of jobs the novas are best suited for and where they can best serve the company. Next, novas are given a training regime designed to improve their particular abilities. This usually combines practical exercises of their abilities with theoretic classes in quantum physics and other sciences intended to help expand their understanding of how their powers work and how best to apply them. Novas with Molecular Manipulation, for example, take classes in Chemistry to improve their understanding of what they can do.

From a DeVries internal memo dated 7/14/02:

From: Dr. Andrew Weisman
 To: Anna DeVries
 Re: Centipede Syndrome
 Ms. DeVries,

Per your instructions, we have been looking into the unusual drop in ability we have recorded among new nova recruits in the first few months of testing and training at our facilities here in Pretoria. Although the data is by no means conclusive, we are prepared to offer a theory as to the cause.

As you know, novas have the ability to manipulate energy on a quantum scale, which necessarily includes the ability to manipulate matter as well. These manipulations occur on a scale so small it can scarcely be imagined, requiring incredible precision directed in an as yet unknown way by the nova's M-R node. When a nova first erupts we believe his state of mind at the time of eruption has a powerful influence on how his abilities manifest. In essence, the M-R node responds in some way to the nova's thoughts and feelings (both conscious and subconscious) at the time of eruption.

Many novas display abilities at eruption far beyond their normal level of performance. This is likely due to the emotionally charged nature of the eruption process. After eruption, a nova's powers settle into a fairly predictable and measurable level, which can be improved through training and practice. One of the initial stages of this training process we have identified as the "centipede syndrome."

There's an old story about a centipede and a grasshopper. The two meet and the grasshopper asks the centipede, "How do you coordinate all of those legs?" The centipede stops for a moment and says, "I never really thought about it." Then, when he tries to get moving again, the centipede starts tripping over his own legs.

It's much the same with novas. Newly erupted novas have no idea how they do what they do, it's instinctual, they just think and it happens, more on the level of a reflex. When novas first begin training they have to think consciously about what they're doing and how they're doing it. This often causes a temporary drop in ability because the nova's conscious mind interferes with the normally unconscious process of their abilities. However, this is a necessary phase if novas are to master their abilities, much less learn new abilities. In any case, our research shows that the problem goes away of its own accord with sufficient training and practice in the space of a month or so.

Regards,
 Dr. Andrew Weisman
 Nova Training and Development

The quantum training of nova elites at the DVNTS base in Namibia includes combat training with their abilities in the Namib or Kalahari Deserts, where DeVries maintains highly complex interactive obstacle

courses and "firing ranges" for the purpose of training novas, with the permission of the local governments. Although DeVries closely monitors all training sessions, accidents can and do happen. A mistake on the part of a nova able to lift tanks and melt steel can be very serious, so DeVries always has a highly qualified team of parapsychicians standing by, just in case. Some DeVries executives have raised concerns regarding the combat training program, but General Carrington maintains the program's importance, and Anna DeVries supports him.

DeVries considers the education and personal development of its people just as important as their nova abilities. Anna DeVries resents the public perception of many elites as "hillbillies with powers" and goes to great lengths to combat that perception. As a polyglot and sophisticated world-traveler in her own right, she cannot stomach the thought of working with oafs and bumpkins. To that end, the company provides a staff of experts to teach nova personnel the skills they need as representatives of the company. It also provides tuition reimbursement and vouchers for novas to attend any university the elites can get into, provided they maintain a suitable grade-point average. Novas having trouble with classes can get tutors and other types of educational assistance. The company particularly encourages nova agents to learn as many languages as possible, to expand the range of countries where they can work without needing translators. The company schedules quantum training and other company functions around the nova's class schedule as needed.

The DeVries Compound, Pretoria, South Africa

The heart of the DeVries corporate empire and home to one of the largest concentrations of novas on Earth, the DeVries compound is located just outside of Pretoria, the administrative capitol of South Africa. The compound occupies some two-hundred acres of private land owned by the DeVries Group and bounded by a high chain-link fence with "No Trespassing" signs posted in English, French, Afrikaans and local African languages. A private road leads into the compound from a guard-shack at the gate, which is manned at all times. Security officers may issue special day-passes and escort guests around the premises. Unescorted visitors are taken to the DeVries security office and telepathically interrogated. Unless they are found to be spies, trespassers are released to the local police, who generally hold them for a few days in their filthiest cells and then release them. DeVries fosters a very close relationship with the local constabulary as a means of keeping conflict with the authorities to a minimum.

The compound itself consists of a large cluster of buildings, including an administrative building, medical facilities, a testing lab, barracks, supply buildings, private bungalows for novas and their families and, on a hill overlooking the living areas, Anna DeVries' beautiful home. The compound also includes a motor pool and private airstrip with hangar facilities and a helipad, a

gymnasium, indoor/outdoor swimming pool and a small artificial lake. The remainder of the grounds are lightly wooded and monitored by sophisticated surveillance devices and DeVries personnel. All approaches to the compound are watched for any signs of intruders, and low-level radar systems at the airfield check for signs of low-flying novas (or missiles) that might approach the area.

In accordance with Anna's wishes, the compound is powered entirely by solar and wind energy to prevent reliance on the local power grid. All the buildings on the compound are built according to passive solar principles and maintain a comfortable temperature range all year round with little if any heating or cooling.

Despite the tight security, life at the DeVries compound is quite pleasant, particularly for the company's novas. They are provided with everything they might need: comfortable housing, fine food, a variety of entertainment and so forth. The compound's kitchen staff of expert chefs can make anything the elites want, at any time of the day, and Anna DeVries herself regularly throws lavish parties for the novas and high-ranking baseline personnel, either at her own home or in the compound's large recreation room. The age of the average elite is 24, and DeVries festivities reflect that fact, with some of these events known to rival the wildest nights at the Amp Room in Ibiza, where the novas throw off their inhibitions (and, often, their clothes).

The DVNTS Base, Windhoek, Namibia

In contrast to the company's South African compound, the DVNTS base in Namibia is decidedly Spartan and perfectly suited to the more militaristic training of DeVries' nova elites. Frank Carrington runs the place like a military base. In fact, some refer to the DVNTS base, unofficially, as "Camp Carrington."

The base is located west of Windhoek, the capital of Namibia, toward the Namib Desert. It is set up similar to a military base, covering a wide area surrounded by a chain-link fence topped with razor-wire and patrolled by DeVries security personnel armed with live ammunition. "No Trespassing" signs are posted just over half a mile from the boundaries of the fence, so anyone approaching the fence without clearance from the checkpoint along the road is presumed hostile. Air-traffic control from the base airfield clears the approach of any aircraft or airborne novas. Those that fail to make radio contact are intercepted by a DeVries nova and ordered to identify themselves or turn back. Those who fail to comply are destroyed. Thus far, DVNTS has not had to go that far to protect its base, but those are Carrington's standing orders.

The base contains an administrative headquarters that serves as the offices of DeVries National Tactical Solutions, including the personal office of Frank Carrington. There are apartment-style barracks for the baseline personnel and private bungalows for the novas living on-base. The base has a motor pool with jeeps and

conventional cars along with light military vehicles and a full airfield for maintaining the company's military-grade aircraft, including helicopters, gunboats and jet fighters. A red flag with the DeVries corporate logo flies above the base in good weather.

Carrington runs the DVNTS base with military crispness and efficiency. The baseline personnel are expected to maintain a certain level of discipline and decorum while on duty. Although the novas at the base are accorded wider latitude, Carrington still expects them to follow a duty schedule and training regime and reminds any recalcitrant novas of their contractual obligations. Fortunately, most of the novas living and working at the DVNTS base actually prefer the paramilitary lifestyle and more than live up to the general's expectations. The elite known as Totentanz lives here when not on assignment, though he rarely interacts with the others except during training exercises. Elites operating out of the DVNTS base consider themselves better trained and somewhat "more elite" than the non-combatant novas based in Pretoria, and friction sometimes arises between novas of the two compounds, though DeVries and Carrington both clamp down on these rivalries quickly and aggressively when they hear about them.

The Elite Culture

One of the keys to DeVries' success is the manner in which Anna DeVries has fostered the growth of a true sub-culture among her elites, a sub-culture that has spilled over to influence elites — and to some degree, novas — everywhere. It fosters the qualities DeVries wants in her people and helps maintain them through bonds of camaraderie and social interaction, without which, she feels, elites would just be isolated loners and thugs.

The foundation of the elite culture can be seen in its choice of terminology. DeVries novas are not just novas, they are elite. They are the best of the best, and nothing is truly beyond them. Most elites embrace this idea readily enough. They consider themselves better than novas working for organizations like Utopia, mass-produced in Rashoud facilities and taught to use their powers for the betterment of humanity. Elites have no such idealistic illusions. Carrington instills a strong sense of esprit de corps in the novas he oversees, and the rigorous training they undergo forges them into a close-knit "tribe" of warriors. The elite ethos is one of looking out for oneself and one's "tribe" first and foremost. It is an elite's job to serve or fight and to earn enormous sums of money by doing so. It is *not* an elite's place to take care of the weak and unfit when they should be working to improve their own lot.

Because of this, a great deal of the elite culture is also nouveau riche. Even inexperienced elites earn a great deal of money very quickly — provided they survive their initial engagements — while experienced elites can earn millions of dollars on a single mission. While elites are on assignment, DeVries provides for nearly all of their agents' daily needs, leaving the elites with little to do

with their money. Anna DeVries insists that elites invest a minimum of 25 percent of their income, but the elites have little to do with the rest of their pay except spend it on random material possessions or vices. Elites, consequently, tend to throw lavish parties and indulge themselves in ways only the truly wealthy can. They cultivate expensive hobbies as a way to spend their money simply because they can. Pursuer's dog breeding and Crystalhawk's collection of exquisite gemstones are both examples of this. Elites throwing money around are a common sight in places like the Amp Room and Star Lord's, where they can be seen arriving in expensive custom-built sports cars, buying Amp Well doubles for the house and engaging the intimate services of inhumanly beautiful nova call boys and girls for the evening.

Finally, elites tend to have a strong motivation to live for the moment fostered by their highly lethal lifestyle. Although not all elites take on military missions, and not all military elites die in combat, the possibility of death always exists, and combat between novas can be deadly in the extreme. Elites are aware of this and therefore live life as fully as possible, knowing each day could be their last. In comparison, the Rashoud facilities of Project Utopia seem like monasteries, where novas live lives of service, contemplation and denial. Elites prefer the grit of real life, with all its blood, sweat and tears; they may take more than their share of lumps, but they also experience the full range of concomitant pleasures and rewards.

Elites, those working for DeVries at least, tend to look out for each other. They share a strong bond, and even elites fighting on opposite sides of a conflict tend to respect each other more than any non-elites involved. Elites consider themselves part of a warrior family, and place that consideration above all others. Elites don't betray or cheat other elites, and they settle their differences fairly. They follow an unwritten code of honor, and an elite's word is his bond. Anything less is a sign of a poseur or a wannabe.

Elements of the elite subculture bear a disturbing similarity to elements of Teragen philosophy, and Teragen sympathies are common among elites. Both groups consider themselves above baselines and above other novas to some degree. Both advocate a personal code of ethics and desire to live life as novas, unencumbered by baseline limitations. However, a key difference is that, in the eyes of most die-hard Terats, elites still serve baseline interests: fighting their wars, selling their products and performing all manner of dirty work that the zips should take responsibility for themselves. To the elites, it hardly matters where the money comes from. If baselines are willing to pay their exorbitant rates, why shouldn't elites take their money?

Costumes, masks and code names

A major part of the elite sub-culture is the use of costumes, masks and code names, or "nova names." The trend first started because elites were concerned about protecting their civilian identities, since many nations saw their actions as criminal. Wearing a mask allowed an elite



to act with anonymity and granted a degree of freedom that few young elites had felt before.

Masks and costumes later became a symbol of the elites' identity, something other people could instantly identify with. Like the war paint or uniforms of warriors and soldiers past, costumes make elites something more than human; they transcend humanity and become symbols. When Totentanz dons his golden skull mask, he's no longer just a man, or even just a nova, he's Death himself, come to claim his next victim. Anna DeVries understands how costumes enhance a nova's sense of power and freedom; the alternate identity helps them to shed their human identities and become something more. For that reason, she encourages novas in her employ, particularly those who see combat on a regular basis, to create and maintain a costumed identity.

Superimpose

Within DeVries is a small independent agency whose entire *raison d'être* is the creation of code names, masks and uniforms for DeVries Elites. Run by the acerbic and uncompromisingly flamboyant Bruce Sauvage, a nova with flawless design sense, Superimpose is often one of the first places a new nova visits when he comes to the DVNTS base for training. Young Elites tend to remember the experience for years afterward.

The Superimpose office is one of the more bizarre buildings on the Windhoek base. Aisle after aisle of odd costumes, dresses, masks, feather boas in a rainbow of colors, leather accoutrements, utility harnesses and odder things dazzle the eye while the ears are deafened by the Ethel Merman and Judy Garland tunes that Sauvage plays at full volume all day long. Many young Elites have claimed that meeting the eccentric Sauvage was the most disturbing part of becoming an Elite.

Sauvage places a great deal of importance on manners, and those who are polite to him are treated very well; they leave Superimpose with an Elite identity such as "Wardog," "Totentanz," or "Tchernabog" that will give them a clear psychological advantage over the competition. Those who are rude or who snicker at Sauvage's... idiosyncrasies walk out of the Superimpose office with identities such as "The Target," "The Boll Weevil" or "The Catamite." Under no circumstances will Sauvage create a new Elite identity for a nova who has been rude to him unless a full and sincere apology is offered in front of all hands. This happens more frequently than might be expected.

The mask in particular has assumed an almost ritualistic role in elite culture. To an elite, the mask represents his nova identity. New elites undergo initiation rituals where they wear their mask for the first time and are called by their nova name, joining the greater family of elites. Victorious elites commonly strip their enemies of their masks (instead of killing them), exposing their human weakness and frailty for the world to see. The masks become trophies, like heads mounted on a wall. An elite

stripped of his mask is ashamed to ever wear it again unless he reclaims it from the enemy who took it. A notable exception is Lance "Stone Badass" Stryker, who lost his mask to rival elite Borealis in 2007. Stryker turned his back on elite traditions and decried the use of masks as "cowardly," earning him the admiration of many baselines, not to mention a huge licensing deal.

Many elites (and other novas) take a "nova name" after their eruption. For some this is a nickname, usually related to their nova abilities, like "Ironskin" Andy Vance. For many novas, the nova name is a marketing tool, like a stage name, since kids are much more interested in having a "Kikjak" action figure — complete with cool costume and mask — than they are in a "Jonas Kincaid" figure, even if they're the same person.

For elites, nova names serve the functions of nicknames and marketing tools, but they are also badges of honor. Like the mask, a nova name shows the elite belongs to a special culture and serves as a hook to hang her reputation on. Nobody knows (or cares) about Totentanz's real name, but his nova name strikes fear into the heart of most novas. To the elites, taking a nova name indicates a break with one's previous, baseline life, a kind of "coming of age" as a nova. DeVries Elites include the taking of a nova name as part of the masking ceremony.

Perks, Bonuses and Benefits

The benefits of working for a company like DeVries, or even working as a freelance elite, are enormous.

The first, and more obvious, is the money. Elites can command large fees, and skilled and reputable elites can write their own ticket. Even with a company like DeVries taking as much as 80 percent of their negotiated fee, elites can earn more in a week than most baselines do in a year, or even a lifetime. Even novas working for Project Utopia, who often command six-figure salaries, don't make as much money as elites (a fact DeVries is quick to point out to potential recruits).

In addition to contract money, there's licensing and residual revenue as well; DeVries licenses the images and exploits of famous elites like Totentanz and Lance Stryker to companies that make toys, comic books, cartoons, OpSites, coffee mugs and nearly everything else under the sun. The elite can also earn money from product endorsements, public appearances, and even speaking engagements. All of that adds up to multiple millions of dollars, and most elites need someone to help manage that money. That's where companies such as DeVries come in. Although DeVries demands a cut of everything its employees make, it also provides financial planning services to help an elite make the most of her earnings, avoid excessive taxes, invest and save.

The second major benefit offered by DeVries is medical care and coverage. Life as a nova, much less an elite, can be dangerous, and DeVries offers the best paraphysicians and medical technology money can buy. No matter what their injuries, novas can be assured they will receive the best of care, with DeVries picking up the

tab. This is particularly appealing to novas with special medical needs. The company also provides full life insurance and death benefits for the nova's partner, family and dependents.

Along with emergency medical care, DeVries has an interest in keeping its novas healthy and provides them with regular checkups, preventative treatments and health-care maintenance, including counseling and therapy, if necessary. Novas suffering from taint get treatment from the best doctors around, although there isn't always much they can do. Still, most novas prefer not to go through such a frightening experience alone.

DeVries makes it clear to prospective employees that the company is on the cutting edge of technology and can afford the very best equipment. The weapons, vehicles, devices and other toys coming out of Dr. Rachel Alinsky's workshop are enough fascinate nearly any techno-fetishist. A tour of the company's R&D labs is often enough to get many novas to sign on the dotted line.

For its exclusive agents, DeVries takes care of nearly all their daily needs. They have housing (at the Pretoria compound, the Windhoek base or company-owned housing elsewhere) and a generous expense account useable for nearly anything the nova wants. The company is also willing to provide any "special" things a nova might want, so long as they will not impair job performance. This includes exotic entertainment, sexual partners, special food, toys and just about anything else the nova might request.

The company provides full legal services for its employees, ensuring things like the registration of the nova's trade name and unique image and handling often sticky legal matters like lawsuits, contract negotiations, licensing agreements and so forth, freeing the nova from having to worry about them. The agency also takes care of any legal "entanglements" novas might have found themselves in before signing on with DeVries including, but not limited to, felony charges.

Perhaps most importantly, DeVries strives to give its novas a home, a place where they feel welcome as part of a community, where they can build relationships with fellow novas. Novas often feel isolated and alone among baselines and even the most antisocial novas often long for a place where they can belong. Such camaraderie is often underestimated, but it is a prime reason why novas flock to DeVries, and Anna DeVries knows it.

The DeVries Fertility Clinic

Ensuring the continued success of the DeVries Agency requires ensuring a continued stream of nova agents and elites. The company does this partly through its recruiting programs, but Anna DeVries takes the long view on things. It's quite likely she, like many novas, will be around a long time, and she expects her company to be around for quite a while after that. That means taking an interest in the next generation of novas.

Unfortunately, evidence gathered by DeVries experts suggests there may not be another generation of novas. A large percentage of novas appear to be sterile. DeVries

set up a clinic in Pretoria to study the sterility problem and, if possible, find a solution. The clinic works with the few DeVries novas able to conceive, and the company covers all their expenses, including generous maternity and paternity leave, in exchange for routine tests to ensure everything goes well with the child's development.

The clinic is currently enjoying its first three successes, and the mood among the three expectant mothers is giddy and hopeful. To give the mothers-to-be greater peace of mind, DeVries has deployed six of its most effective elites, including the dreaded Totentanz, to guard the three during their pregnancy. No one is surprised at the lengths the company is going to: One of the mothers-to-be is Anna DeVries herself.

Sanctions

DeVries prides itself on complete customer satisfaction. Its elites are the best trained, most effective and most visible, which makes those occasions when a DeVries Elite screws up all the more significant. Anna DeVries understands that mistakes happen, but she will not suffer incompetents, and she takes a severe dislike to elites who lie to her, cheat her or fail too frequently to achieve their assigned objectives. This is why sanctions exist.

DeVries has several degrees of sanctions for dealing with problem novas. The first and simplest of these involves cutting back on the contracts offered to the nova and assigning various sorts of "scut work." This gives the nova the opportunity to think about the error of her ways while slogging through a malarial swamp in some godforsaken third-world country, doing guard duty at the most boring post DeVries can find or pulling extra training shifts while waiting for a new assignment. Most elites accept this punishment with minimal complaint, since further defiance may lead to more severe sanctions.

A second-degree sanction typically involves a formal reprimand, entered into the elite's work record with DeVries and made available to potential clients, who may consider the nova too problematic to work with. The elite may also be shuffled to the bottom of the stack of potential candidates for certain jobs and a pay cut is possible, though not inevitable, depending on the nature of the transgression. Success on two or three assignments and scrupulous adherence to regulations can eventually erase a second-degree sanction from the nova's record (or at least get it removed from files viewable by clients).

With a third-degree sanction, DeVries may suspend an elite for a period of time due to serious breeches of protocol or major incompetence, particularly if there's evidence of willful misconduct or negligence. A suspension may last anywhere from a week to months. During that time, the elite is not permitted to take any assignments with DeVries, nor may elites with exclusive contracts accept outside jobs. Although this can be a financial blow, most elites have enough money that it's not a major concern. The embarrassment and scorn from one's fellow elites, on the other hand, are powerful motivators. Furthermore, elites placed on suspension become

less desirable to potential employers, even more than those novas with a reprimand or two in their files. Few elites are willing to risk disciplinary action beyond this level.

Finally, in cases of extreme dereliction of duty or repeated willful misconduct, DeVries may place an elite “beyond sanction.” This involves dismissing the elite from the company and generally blackballing him or her throughout the elite industry. These individuals are considered a shame to their field and an embarrassment to nova-dom. Few legitimate employers are willing to contract an elite with such a record, and the elite community as a whole shuns them and treats them as non-persons. An unspoken agreement exists that makes elites placed beyond sanction “fair game” should the elite ever take to the field in the future, and “accidents” have been known to happen where such elites end up dead in the “confusion of battle.”

For DeVries, putting an elite beyond sanction involves a ritual led by Anna DeVries, similar to a religious excommunication. The nova is formally banned from all DeVries properties, expelled from elite society and declared no longer worthy to use a code name or wear a mask or uniform. DeVries Elites are forbidden to associate with these outcasts (as if they’d want to) and tend to speak of them in the past tense, as if they were already deceased.

Outside Relations

Project Utopia

Project Utopia and the DeVries Group theoretically sit at opposite ends of the ideological spectrum. Utopia seeks to make the world a better place for everyone, nova and baseline alike. DeVries seeks to make a lot of money off nova skills, by any means available. DeVries Elites are tearing Africa apart, while Utopia works to make Ethiopia a paradise on earth. Utopia works to encourage peace talks between India and Pakistan, while DeVries turns Pakistan into an armed camp.

It’s no surprise that the two organizations don’t get along. Utopia often tries to drag DeVries Elites into the UN’s International Court of Justice, and encourages nations to stop using elites. DeVries undermines Utopia’s reputation with nationalist interests the world over and steals away Utopia’s personnel, both nova and baseline. And around and around they go.

One of the reasons for the enmity between Utopia and DeVries is that they share too much in common. Both are vast and hugely profitable organizations. Both command a small army of novas. Both meddle in international affairs. Most importantly, though, they both compete for the same resources and many of the same customers, dividing up the world between them. It is their similarities more than their relatively minor ideological differences that cause friction between the two organizations.

The Directive

DeVries maintains reasonably cordial relations with the multinational Directive, although neither side is naïve

enough to trust the other. DeVries and the Directive do share some qualities in common, including reasons to dislike and distrust Project Utopia. The Directive has been known to look the other way when it comes to DeVries operations, and Anna DeVries quietly encourages the idea that her agency helps serve as a counterbalance to Utopia’s power and influence, making DeVries an ally of sorts for the Directive.

The Directive does not use a large number of nova agents, but when it needs additional nova personnel, it gets them through DeVries. The Directive most commonly hires elites for more overt missions or to provide a useful distraction for their real agents. Anna DeVries is well aware the Directive considers her people disposable when it comes to achieving their goals, but the Directive pays well and occasionally lets slip information valuable to DeVries. Consequently, she does her best to maintain warm relations with the intelligence agency.

The Teragen

Although Anna DeVries and a number of her novas have Teragen sympathies, the feeling are definitely not mutual. Overall, the Teragen consider DeVries — and all other — Elites little more than prostitutes, turning their backs on their true potential as novas, selling their abilities to the highest baseline bidder, fighting the zips wars for them and dying for their causes, all for nothing but greed. Anna DeVries and her closest advisors are the worst of the lot because they lure other members of the One Race into a life of baseline servitude. Terats are encouraged to have nothing to do with elite agencies such as DeVries and to encourage others to do the same.

Some Terats have taken their ideological differences a step further and attacked DeVries facilities, including their offices in New York City, in order to make clear their disapproval of the agency’s practices and to help “liberate” novas working for the agency. These attacks rarely result in anything more than nova casualties. From time to time, the Teragen even manages to convince elites to leave DeVries and join their revolution. Needless to say, these attacks are of great concern to DeVries. The company makes every effort to ensure the safety and security of its facilities. Attempts to negotiate with the Teragen have proven fruitless, since Terats are both notoriously independent and unwilling to negotiate regarding DeVries’ “exploitation” of novas.

Anna DeVries has most recently been trying to make contact with Divis Mal, the Teragen’s enigmatic leader, to speak with him personally and ask that he rein in his organization’s attacks on DeVries; while she has had no luck in making contact, the Directive has taken note of her attempts and is watching her very closely for active Teragen sympathies.

Aberrants

For the most part, the DeVries Agency has little or nothing to do with the Aberrant movement or accusations of a conspiracy within Project Utopia. Anna DeVries

watched the media circus touting corruption within Utopia with great interest and amusement, but DeVries has no interest in the political goals of the Aberrants — unless they ask for work, in which case she'll take them on. The agency has made efforts to recruit some disaffected Utopian novas with promises of shelter, substantial salaries, legal assistance and other benefits, but they've been largely unsuccessful. The Aberrants appear devoted to their nebulous cause and are frequently fearful of their own shadows, which makes them poor recruits for a mercenary company.

Still, Aberrant money is as good as anyone else's, and many Aberrants have considerable financial resources tucked away. DeVries has no problem hiring out elites if the Aberrants are willing to pay, especially if it is likely to cause trouble for Utopia.

Other Elite Agencies

Although DeVries is the unquestioned number one nova agency in the world, it is by no means the only one. A number of other elite agencies have sprung up in the wake of DeVries' success (some of these are described in Chapter Two). These smaller agencies compete with DeVries in a variety of areas, each seeking a niche they can dominate. This strategy allows much smaller companies to compete successfully with DeVries, albeit in proscribed areas.

Although DeVries certainly views these other agencies as competitors, it is large and influential enough to afford to be magnanimous in some regards to its smaller competitors. Anna DeVries encourages the spread of the elite culture her agency established, and DeVries tries to cultivate cordial relations with its competitors, sub-contracting extra work to them, setting up legal and business resources that benefit all elite agencies, and providing references for new agencies DeVries finds reputable. For DeVries, the brotherhood of elites comes before any business competition, and this attitude has won the company at least the grudging respect, if not admiration, of other agencies.

DeVries is still a business, however, and they are quick to seize opportunities. If a small elite agency flounders, odds are good that DeVries will offer to buy them out, along with their agents' contracts and their client database, giving the company new life as another branch of the vast DeVries empire.

Public Relations

Public relations are vital to a company like DeVries, at least as much as they are to Project Utopia, perhaps even more so. The DeVries public relations machine works tirelessly to maintain and improve the company's reputation around the world, to counter any bad press DeVries gets and to play up and create good press for the company in the media. The company's success is owed in no small part to the efforts of its PR department, which have made DeVries one of the most popular nova organizations in the world.

From a DeVries inter-office memo:

From: Juliette Keller, Public Relations

To: Anna DeVries

Re: Nigerois conflict

Anna,

We have Gaal and Najarian's footage of the encounter in Niger between some of our people and Project Utopia. The 'Topians have been very touchy ever since Antaeus decided to "take an extended leave of absence" and oversee the terraforming project in the Sahara personally. The trouble at the oil fields was little more than a skirmish, when 'Topia's people got too pushy, but we have some great shots that make them look like the aggressor, while our people are just doing their job, protecting the Nigerois national interests they were hired to protect.

We're doing a quick storyboard and rough edit now. I should have something ready for your approval — and the news services — by the end of the day. N! and the other networks will eat this one up. I guarantee it. We're going to have to be extra nice to G&N for a while. Can we buy them armored cameras or something?

Julie

DeVries banks on the idea that "there's no such thing as bad publicity," and it seems to work for them. While there are certainly times when the PR department is called upon to put out a fire, the coverage DeVries gets through the mainstream media is almost overwhelmingly positive, no matter how nasty things get. In fact, in many cases, the bloodier the conflict, the more people howl for more. Video footage of DeVries Elites in action on the battlefield is pure gold, even if — especially if — it involves Totentanz putting a spear through somebody.

OpNet and other media

PR's prime venue for reaching the general public is of course the OpNet and the various information and entertainment networks that operate on it.

To begin with, DeVries maintains an extensive OpSite of its own, with information about the company's history, services and employment opportunities, along with extensive coverage of the activities of DeVries Elites and opportunities for users to customize the site to bring them news and information about their favorite elites. The site serves as a business tool for advertising and providing information to customers, but it is perhaps more important as a PR site. Over a million fans and elite-watchers access the site every day to keep up on the activities of their favorites. DeVries even won praise from media watchdogs for installing measures in their site that allow children to access it without being allowed access to the more "adult" information (including explicitly violent video clips).

The PR department maintains a delicate balancing act with the major networks, providing them with footage, information and sound bites, but shielding the agency's secrets and throwing up smokescreens when necessary to protect a covert operation or a client's anonymity. For the most part, the networks cooperate with DeVries, since few things bring in the ratings like stories of elites in actions. N! was the first to realize this, and

DeVries still maintains good relations with the network because of it.

The agency quietly encourages the proliferation of OpSites dedicated to DeVries and its various elites, and the number is almost countless. Elite fans put up sites devoted to their favorite elite(s), with pictures, personal stories and rampant speculation. There are also OpNet chats and message boards where people talk and gossip about the elites. DeVries encourages its novas to make personal appearances at some of the major sites from time to time, generating a flurry of interest.

DeVries also makes full use of print media to get the word out about the agency and its novas. They provide material for magazines and newspapers hungry for images and quotes from famous novas, and nearly every major public DeVries operation is followed up almost immediately by a “tell all” exposé book available in bookstores world-wide. Books like *Elites at War* and *The Kashmir Conflict* regularly hit the bestseller lists.

Elite Licensing

One of the greatest successes for DeVries has been licensing the names and images of various novas, thereby netting the company millions of dollars in revenue. DeVries serves as a “talent agency” for novas, and the PR department aggressively markets the agency’s novas to major advertising firms and corporate clients. Although nearly any nova can earn a reputation and a licensing deal, they don’t have the vast DeVries public-relations machine behind them — to say nothing of the legal department, which gives elites advice on potential licensing deals and helps identify the most lucrative contracts.

Licensing is a gold mine for the PR department, since it not only earns the company money in the form of licensing fees, it also has major corporations and even nations paying DeVries to promote its novas to potential clients around the world. So when Tama lends his name and image to a manufacturer of firearms, for example, or Lance “Stone Badass” Stryker shows up to promote a new sports drink, it only improves the image of DeVries in the eyes of the world.

Gaal and Najarian

More footage of quantum conflict has been filmed by these two nova correspondents than all other reporters and networks combined. Their names are household words. They’re worth millions. Their work has won the Academy Award for Best Documentary six years running. Project Utopia considers them a nuisance. The Directive considers them a tool. DeVries considers them friends and the best of all possible PR teams. But to all but their agent and friends, the story behind the world’s best known cameramen remains a mystery (until the release of their meta-documentary “Behind the Dangerous Lens” in the fall of 2015).

Before their eruptions, both felt trapped in relatively tedious jobs. Chris Gaal was a digital-effects programmer in Los Angeles, and James Najarian taught Victorian poetry at Boston College. Both erupted in 1999 under radically different circumstances. Gaal was mugged early one morning after lingering too long in a seedy bar in L.A.’s Chinatown. Najarian erupted when his parachute didn’t open on a skydiving trip with friends. Both developed, among other things, the ability to fly and a certain degree of invulnerability. They met at a Project Utopia training camp for the “aerially gifted” and took an instant liking to one another. After many hours of conversation, they came up with the idea of filming the exploits of their fellow novas and selling the footage to the highest bidder.

They made their first million within six months.

Since then, the two have covered every mid- to large-scale nova conflict around the globe, from Team Tomorrow’s raid on the Islamic Dawn compound in Al-Burhan to the latest escalation in Kashmir.

DeVries frequently asks Gaal and Najarian to film the exploits of its up-and-coming elites; in exchange, DeVries gives the cameramen advance notice when large-scale elite conflicts are about to break out. More recently, Gaal and Najarian have taken contracts through DeVries to film events for DeVries’ clients; in lieu of pay, Gaal and Najarian have requested the free services of certain extremely stealthy elites, and Anna DeVries herself has given the arrangement her blessing, though she’s curious what the film-makers have up their sleeves.

From: Anna DeVries
To: Juliette Keller, Public Relations
Re: Toy Sales
Julie,

I’m very pleased with the latest numbers on our toy licensing sales. I can only imagine how much it must gall Project Utopia that our elite series is outselling many of Utopia’s figures and toys from Novation.

I agree we should strike while the iron is hot. Go ahead and put together a proposal for new elites to add to the Novation licensing deal. I’d suggest Tama and Tank, to appeal to the Asian market, along with Lotus Infinite and Zephyr for the girls. Talk to Constantina and let’s see if we can work in some tie-ins to her animated series. If business keeps going as it has been, we’ll want to talk to Novation about a whole series of “underground” toys based off it. Dangle that on in front of them, and see how they jump.

Follow up on the video-game properties. I like the proposal from Disney-Apple the best so far, but I also want to make sure this game is good and reflects well on us. I won’t have our name associated with shoddy merchandise. Stay on top of quality control for this one. We will have final approval before anything goes out, even beta tests.

My best to Karl and the children,
Anna

The Toy Business

An unexpected area of success for DeVries is in the area of toy licensing and merchandising, a source of endless amusement to Anna DeVries and endless frustration to the Project Utopia public relations division. DeVries licenses the names and images of its novas to companies producing action figures, comic books, cartoons, board games, roleplaying games and trading cards.

Toys and products based on elites are hugely popular with children, especially boys, although DeVries PR is working on some angles they hope will appeal to girls as

well. Children buy action figures of elites and watch their exploits on N! and in animated shows. The *Elite Action!* trading card series is hugely popular, spawning a tremendous collectors market in the United States and abroad. Stores regularly sell out of the cards, and accuse Novation of deliberately creating a shortage to drive up prices and stoke “elite fever.”

Elite toys aren’t just children’s products either. There’s a booming speculation and collector’s market for every kind of elite merchandise, from action figures to comics to resin models of popular elites. OpSites are filled with buying, selling and trading of merchandise, all of which only increase public awareness of, interest in and support for DeVries and its elite mercenaries.

Public Appearances

The Public Relations department encourages DeVries’ novas to make public appearances whenever possible and arranges speaking engagements, exhibitions and other venues. Some of these involve large fees, while others are free or have the proceeds donated to charity. From a PR standpoint, even a free appearance makes up for the time in good PR and public exposure. Therefore, DeVries Elites are often seen at high-profile social events around the world, and even their daily lives are subjects for the media’s voyeuristic eye. The PR department coaches elites to be mindful of the public eye at all times, and their public appearances are all carefully orchestrated behind the scenes.

The Pomme d’Or

One “public relations” tool in DeVries’ arsenal is the company’s private cruise ship the *Pomme d’Or* or “Golden Apple.” Anna DeVries purchased the ship from a failing cruise line and had it outfitted as a floating resort, meeting place, vacation spot and pleasure palace. The ship spends most of its time in international waters, outside the jurisdiction of any nation, where company rules and clients’ desires are the only law.

The lavish parties DeVries throws on board the ship are legendary in nova circles, rivaling the debauchery of the Amp Room and — if the stories are to be believed — exceeding it at times. These gatherings serve as a valuable reward and release for DeVries Elites, an opportunity to network with other elites and a perfect setting to impress potential new recruits with some of the benefits of working for the DeVries Agency. The company also uses the *Pomme d’Or* to entertain baseline clients, and Anna throws an annual four-day, invitation-only party for the agency’s best clients. Such soirees give a whole new meaning to the term “customer satisfaction,” and clients leave at the end somehow feeling like they owe DeVries a favor.

The cruise ship serves as a mobile meeting place for business dealings in international waters, as well as a haven for DeVries to hide any “hot” novas sought by national or international agencies, until the legal department can make the problem go away or at least find a

temporary solution. So long as the ship remains in international waters, it remains an untouchable island of DeVries sovereignty.

Executives

Anna DeVries

**President and CEO, DeVries Agency and DVNTS;
Director, DeVries Group**

Background: Anna’s father taught her to play tennis at the age of 12, to shoot at 14, to flirt at 16, to lie at 18 and to run a business at the age of 22. Although he allowed prep schools, Cambridge and Harvard to finish her education, he always felt responsible for teaching her the important things.

As a result, Anna grew up as canny as her old man. Now, at 32, she arrives at her business meetings tanned, toned and prepared, confident that even if her Harvard MBA fails her, her father’s lessons will not.

In some ways, Anna is even cannier than Holger. She’s not blind enough to be prejudiced against black South Africans, as her father is, and her mercenary company is more successful than his ever dreamed of being. Part of her success stems from her ability to empathize with both clients and employees. She doesn’t appear frighteningly “nova” to baselines, and it doesn’t hurt that her only known power is her ability to disrupt other novas. But, more to the point, clients appreciate her shrewd business sense. Not only does she have an instinct for picking the right clients, she runs DeVries with the combination of discretion and promotion those clients require.

On the other hand, she joins the elites working for DeVries in the shooting range, on the tennis court and in the spa. She’s even appeared discreetly at the Amp Room a few times, where, to everyone’s delight, she’ll undo her trademark blonde braid and dance. More often, she spends her time there reminiscing with Jake “Dragon” Korelli, a friend and occasional employee. She also uses the time to chat up other novas. This socialization is important to her; she feels occasionally that she needs to compensate for being a woman in the male worlds of executives and mercenaries.

The DeVries novas like Anna, although some find her strangely intimidating. The story of Anna’s eruption is well known among DeVries employees: Anna was walking down a street in London, when, a block away, a man tried to mug Hazel Dryden. Hazel erupted, emitting a devastating wall of sound that shattered glass and eardrums for blocks until Anna erupted and stopped her. Dryden, as Crystalhawk, signed with DeVries in its first year.

While Anna rarely uses her ability to disrupt other novas’ powers, she takes a certain secret pleasure in thinking of it as a sword of Damocles hanging over the heads of her employees. DeVries’ true power, which she calls the Brain Burner, is a secret she prefers not to let out. She has used it



on only four occasions, and only when a rogue nova was preparing to do her harm, but it has been lethal every time. She considers it her ace in the hole when dealing with some of the dumb-but-powerful types who wander into the mercenary life because they have no other prospects.

Ironically for someone who serves baseline clients and can disrupt the abilities of other novas, Anna has distinct Teragen sympathies. She enjoys working with baselines and does not discriminate against them as individuals. Peripherally, she acknowledges that they are her family, friends and lovers, and she would never want to see them under the kind of apartheid system she remembers from her youth. That said, she has a hard time caring for baselines as a demographic; they interest her less than novas, and she agrees with *The Null Manifesto* down to the letter. She barely regrets her agents' collateral damage, though she hides it well. How baselines choose to harm one another is of very little consequence to her.

Over the years, she's come to see her role as helping her and her fellow novas get rich from baseline resources. And if DeVries' contracts in developing nations mean that she is starting to control a modest portion of the world's mineral wealth, so be it.

Because of her sympathies, she has almost blinded herself to Frank Carrington's duplicity. She trusted him for years, as an employee and a lover, in part because she didn't think he posed a threat. It hasn't helped that she depends on him as one of the few stable elements of her otherwise very stressful life; she's known him since she was 16, and while the balance of power in their relationship shifts between them frequently, he has shown his loyalty to her on frequent occasions. She enjoys their many little power games, as they appeal to her competitive streak and heighten his attractiveness to her. While Anna is perfectly aware that Carrington is trying to amass enough followers to leave DVNTS and start his own company, she hasn't yet decided how to deal with him. She could stop him easily if she chose to, but she prefers to wait and hope that he changes his mind. In the meantime, this betrayal by a baseline is pushing her to commit more fully to the Teragen philosophy.

Anna is currently one of three pregnant novas in the Pretoria compound, though she isn't letting her condition interfere with her control of the company in the least. She intends to show the world just how effectively a nova can carry off the twin roles of mother and executive.

Image: Anna DeVries looks as if she models safari-style clothing: tall, slender, hazel-eyed and fit, with blond hair and golden skin. Her well-draped linen suits are from a considerably more urban designer, though. Those form the backbone of her corporate wardrobe.



Outside the office, she wears clothing appropriate to her situation: desert fatigues when surveying a battlefield, formal wear in casinos and chic parties.

Roleplaying Notes: You are a strong-willed young woman, supremely sure of your own abilities and the abilities of those in your employ. Never having failed in life, you tend to be overconfident. This can lead you to dismiss potential threats to your company's welfare (such as that posed by Carrington) until it is too late. An expectant mother, you eagerly await the birth of your child, looking forward to the day you can pass on your wealth of knowledge to the next generation of the DeVries family.

Gear: Whatever she may need.

Nature: Leader

Allegiance: DeVries, Teragen

Attributes: Strength 2, Dexterity 4, Stamina 4, Perception 4, Intelligence 5, Wits 4, Appearance 3, Manipulation 5, Charisma 4

Abilities: Academics 4, Athletics 4, Awareness 3, Biz 5, Bureaucracy 4, Command 4, Computer 2, Drive 3, Endurance 3, Etiquette 3, Firearms 2, Intimidation 1, Investigation 2, Linguistics 2 (English, Afrikaans, French), Pilot 1, Resistance 3, Stealth 2, Style 3, Subterfuge 4

Backgrounds: Allies 5, Backing 5, Contacts 5, Dormancy 3, Followers 5, Influence 5, Mentor 1, Resources 5, Quantum 4, Quantum Pool 28, Willpower 10, Taint 2

Powers: Mega-Intelligence • (Mental Prodigy: Financial), Mega-Manipulation • (Persuader), Mega-Charisma ••• (Commanding Presence), Disrupt •••• (Extra: Extra Power), Mental Blast ••••• (Extra: Aggravated)

Frank Carrington

Vice-President, DVNTS

Background: Former British General Frank Carrington always admired Anna DeVries, but never expected to work for her. He joined Executive Actions in 1989, after a se-

ries of disagreements with the Thatcher government led him to resign his position. In the world's most renowned private military company, he found what he was looking for: constant combat, without the political nonsense he had been forced to deal with in his old life. He moved out of his family's old Shropshire house for good, settling in Cape Town near Holger DeVries, his employer and good friend. When Executive Actions ceased its activities, he resigned himself to occasional consulting work with other mercenary firms and a hobby of deep-sea fishing.

He was bored, though, and eagerly accepted Anna's invitation to train her mercenary novas in combat and tactics. He was amazed at what his friend's daughter had become: a leonine young woman with a head for warfare and business that surpassed even her father's. Working more closely with her, he became both her lover and her confidant. She grew to rely on his administrative skill and his ability to foster a traditional military camaraderie among her elites, and he became Chief Elite Administrator in 2000. He was a natural choice to oversee DeVries National Tactical Solutions.

Something about the split irritated him, though, as did the subsequent recruitment of non-combatant novas. Carrington has a deep distrust of political maneuvering and spin-doctoring, and Anna has done a lot of both in the past few years. She has even interfered with his command and contractual decisions for publicity purposes, and he grows increasingly resentful of her meddling. He feels the company is moving away from its original vision, and proud of his elite forces, he doesn't want to see that happen. Surreptitiously working his contacts in the corporate community, Carrington is sounding out both clients and elites to try and lure them to his own company. Being a man, a general and a well-known mercenary helps his cause. While he may not be able to split off yet, he's confident enough to try in a year or so. Whether he's underestimating Anna or not remains to be seen.

Image: At home, Carrington doesn't look like a general. In his 50s, with a penchant for cardigans and loafers, he could easily be mistaken for an office manager. He's wiry and tall, with long arms and legs. His beaky nose pokes out under pale blue eyes. However, any absurdity or softness in his appearance vanishes when he puts on his general's uniform. Both intense and reserved, he sports a dry sense of humor and a magnetic way of drawing people to him. Carrington enjoys popularity among his trainees, despite certain priggish social attitudes. He never smokes or drinks ("filthy habits," he says).

Roleplaying Notes: You are a brilliant military tactician with an almost instinctual understanding of small-unit skirmishes gained from more than three decades of experience commanding the SAS, Executive Actions and DVNTS. Your men trust you implicitly, and you will never betray that trust. Nor will you allow anyone else, even Anna, to do so. You fear that Anna has gone soft and now wants to distance herself from the proud mercenary elites that built DeVries. You eagerly anticipate the birth of your child,



hoping it's a boy. You believe that such a child, a born nova with the blood of both Holger DeVries and yourself flowing through his veins, could grow up to become the finest elite soldier the world has ever seen. If only you can stop Anna from thwarting the child's potential.

Gear: Military uniform, laser shock pistol, armored aircar

Nature: Traditionalist

Allegiance: DVNTS

Attributes: Strength 4, Dexterity 3, Stamina 3, Perception 3, Intelligence 3, Wits 4, Appearance 3, Manipulation 3, Charisma 5

Abilities: Academics 3, Athletics 4, Awareness 2, Biz 2, Brawl 3, Bureaucracy 4, Command 5, Computer 3, Drive 2, Endurance 3, Firearms 5, Intimidation 3, Legerdemain 2, Linguistics 1 (English, Afrikaans), Might 2, Perform 3 (Trumpet), Pilot 1, Resistance 2, Stealth 3, Subterfuge 3

Backgrounds: Allies 4, Backing 4, Contacts 4, Followers 3, Influence 3, Resources 4

Willpower 6

Rachel Alinsky

CTO and Director of Research and Development, DeVries Agency and DVNTS

Background: Rachel was drawn to science and engineering out of a need to prove her worth to her parents and to her brothers. It was, for her, a herculean task and one she never mastered; her brothers excelled at academics, graduating as valedictorians of their high-school classes and going on to Caltech and MIT respectively. Determined to compete, Rachel studied intensely, but still graduated fifth in her high school class. Her parents were mildly disappointed, though not surprised. This lesser performance was still quite enough to gain her admission to MIT, where she enrolled in the Electrical Engineering/Computer Science program. Although fanatically determined to prove

something to her family and to the world, she found the intensity of the MIT workload increasingly difficult to endure. Her frustration reached a crisis late one night in January 2000 (the end of first semester, junior year). The crucial final project in her robotics class was due the next day, and the stress of weeks of failure to produce a working version of her design led to the eruption of her M-R node. Understanding settled across Rachel's mind like snow falling on the domes of MIT, and she finished the project within 20 minutes. In subsequent semesters she quintupled her course load, then quintupled it again as her node continued to develop, and still she wanted more. The anger she had harbored for years toward her brothers and her parents fueled her drive to master everything MIT had to offer. By the spring of 2002, less than 18 months later, she had drunk so deeply of the MIT knowledge reservoir that she was able to graduate having fulfilled the requirements for three Bachelors, three Masters and two Doctoral degrees. During this prodigious hurricane of intellectual voracity, Rachel was approached repeatedly by Project Utopia representatives, but she rebuffed them, concerned only with consuming and processing as much of MIT's intellectual smorgasbord as she could possibly manage. Her father approached his South African business contacts, informed them of Rachel's scientific virtuosity, and shortly after Rachel's graduation, he introduced his daughter to Anna DeVries herself.

The generosity of DeVries' offer, in terms of both financial compensation and absolute freedom to research and build "cool stuff," along with her father's declaration that she'd "be stupid to turn down such a chance," convinced her that this was the best possible career move for her. The arrangement has worked well for both parties. Rachel's research has consistently led to the most devastating devices and vehicles used by elites in the field, but she's growing bored with "standard" technology. Rachel currently finds herself fascinated with genetics and the potential of nanotechnology.

Rachel detests the weekly meetings that she, as Chief Technical Officer, is obligated to attend. She likewise detests office politics, particularly the power games between Anna DeVries and Frank Carrington, but she does her best to downplay these details because she is quite sure there is no other place that would give her a research budget anything like what she currently has.

Image: Dr. Alinsky has a round face and wears her hair short to keep it out of her eyes. She rarely pays any attention to what she's wearing, leaving those sorts of details to her valet, who does what he can to keep her from going out in worn and wrinkled clothes.

Roleplaying Notes: The nova equivalent of the absent-minded professor, you're too busy thinking up new ideas and tinkering with new devices to be bothered with anything else. Despite your lack of social skills, you are beloved by the numerous DeVries Elites whose lives your many devices have saved. Though you aren't one to express such emotions outwardly, this praise means a great



deal to you, since no one in your family was ever pleased with your performance. This, in turn, drives you to work even harder to create better gadgets and weapons to turn the tides of battle and keep “your elites” alive.

Gear: Brain-implant data connection with full OpNet, a plethora of nanotech devices in various stages of functionality

Nature: Analyst

Allegiance: DeVries

Attributes: Strength 2, Dexterity 3, Stamina 4 (Unflagging), Perception 4 (Intuitive), Intelligence 5 (Pragmatic), Wits 4 (Ingenious), Charisma 2, Manipulation 2, Appearance 2

Abilities: Academics 2, Bureaucracy 4 (Procedures, Requisition), Computer 5 (Data Retrieval, Programming), Drive 2, Endurance 4, Engineering 5 (Armaments, Computers, Electronics, Energy Sources, Telecommunications, Vehicles), Intrusion 5 (Countermeasures, Electronic Infiltration), Investigation 4 (Deduction, Research), Resistance 3, Science 5 (Chemistry, Physics, Mathematics)

Backgrounds: Allies 4, Backing 4, Contacts 4, Resources 4 Quantum 4, Quantum Pool 28, Willpower 8, Taint 0

Powers: Mega-Perception •••• (Electromagnetic Vision), Mega-Intelligence ••••• (Analyze Weakness, Eidetic Memory, Mental Prodigy: Engineering and Scientific, Speed Reading) Mega-Wits ••• (Multitasking)

Mark Temenke

Head of Human and Nova Resources, DeVries Agency

Background: Mark Temenke always had a way with people. From the time he was a very young boy, everyone always told him how charming he was. By the time he was a young man, Temenke was practiced in the use of his charm to get things done. One of the people he charmed was Anna DeVries. The two of them met at Harvard, where they were both enrolled in the MBA pro-

gram. Temenke was taken with DeVries’ spirit and determination, to say nothing of her looks, and she was equally captivated with his wit and charm. They dated briefly, but after a few weeks decided they were better off as friends.

Years later, Temenke was working as Director of Human Resources for Time-Warner, working his way steadily up the corporate ladder. That was when the first stories about the DeVries Agency began hitting the media. Temenke called in some favors to track down Anna DeVries and plied her with his charms once again, convincing her that he was the only person to run the human resources department at her company. DeVries only laughed and told Temenke she was planning on calling him anyway. Within days, Mark Temenke was on his way to Pretoria.

Since then, he has run the Department of Human and Nova Resources at DeVries with enough aplomb to help secure the company’s reputation for complete customer and employee satisfaction. Temenke loves his work and the incredible variety of people it brings him into contact with. About the only person he doesn’t get along with is Frank Carrington. Carrington isn’t swayed by Temenke’s charms, and he finds the general rigid and suspects he’s up to something. Temenke’s also more than a little jealous of Carrington’s relationship with Anna DeVries, although he’d never admit to it.

Image: Mark Temenke is a handsome African man with an easy smile and a pleasant voice. He’s in fine shape and keeps himself that way with a daily regime of jogging and tennis or racquetball. (He meets Anna on the court at least twice a week.) He tends to dress in “business casual,” disdaining ties altogether. Like his manner, his appearance seems calculated to make others feel at ease around him.



Roleplaying Notes: You love your job because it allows you to ply your considerable charms. You're always meeting new people, baseline and nova, and they invariably like you. You still carry a torch for Anna DeVries, but you've resigned yourself to the fact that your time together passed long ago.

Gear: Cell phone, flying bike, laptop computer

Nature: Conniver

Allegiance: DeVries

Attributes: Strength 3, Dexterity 2, Stamina 3, Perception 4, Intelligence 3, Wits 3, Appearance 3, Manipulation 3, Charisma 5

Abilities: Academics 4, Athletics 3, Awareness 3, Biz 3, Bureaucracy 5, Computer 3, Drive 1, Endurance 2, Etiquette 3, Intimidation 2, Linguistics 1, Rapport 4, Stealth 1, Style 3, Subterfuge 3

Backgrounds: Backing 4, Contacts 4, Resources 4
Willpower 5

Bayo Owodunni

CFO, the DeVries Agency

Background: Bayo Owodunni achieved a great deal for a black woman in a South Africa under the thumb of apartheid. She educated herself and worked for a wealthy and powerful man, Holger DeVries, as his personal secretary. Although Mr. DeVries never looked too kindly on Owodunni, he did respect her work and paid her well. DeVries' daughter Anna was much kinder to her, and treated her like a real person instead of a paid servant.

When the walls of apartheid crumbled, Executive Action was gone, and Owodunni found other work, since her skills were still in demand. She was quite surprised when Anna DeVries contacted her about a new opportunity, an offer that surprised and delighted Bayo, and one she accepted immediately. She became the Chief Financial Officer of the DeVries Agency, responsible for the company's fiscal health, a duty she takes very seriously. Under her guidance, DeVries has spent where and when it needs to spend and saved and invested wisely, optimizing use of the company's resources.

Image: Bayo Owodunni is an African woman with a full-figure and rather plain features, but with an infectious laugh. She wears business attire at work, usually a skirt and blazer with a colorful blouse. She's rarely seen without her omnipresent palmtop computer, which she uses to stay on top of a dozen different projects at once. She is stern with people in the way that a mother can be stern but equally flexible and helpful.

Roleplaying Notes: You couldn't be happier working for DeVries, and your ample salary supports you, your husband and your three children, who live at the company's Pretoria complex. You have truly grown into your position and are respected throughout the company for your down-to-earth attitude and willingness to do what it takes to make things happen.

Gear: Palmtop computer, cell phone, Sony chip player



Nature: Caregiver

Allegiance: DeVries

Attributes: Strength 2, Dexterity 2, Stamina 3, Perception 3, Intelligence 4, Wits 3, Appearance 2, Manipulation 2, Charisma 3

Abilities: Drive 1, Resistance 1, Awareness 3, Investigation 3, Academics 2, Bureaucracy 5, Computer 3, Linguistics 2, Biz 4, Rapport 2, Intimidation 2, Style 2, Streetwise 2, Subterfuge 2, Etiquette 2

Backgrounds: Backing 4, Contacts 3, Resources 4
Willpower 5

Christian James Wether

Executive Legal Officer

Background: Christian James Wether is known as one of the most brilliant — and one of the most unorthodox — attorneys the British bar has ever produced. At the top of his graduating class at Oxford, Wether quickly earned a reputation as a legal mercenary available to the highest bidder and capable of reducing his legal opponents virtually to tears, both in the conference room and the courtroom. He combined golden oratory with cunning legal maneuvering and the hunting senses of a shark. Such a background made him perfectly suited to become DeVries Executive Legal Officer, in charge of the company's legal affairs, particularly the issues of national and international law in which DeVries finds itself almost constantly entangled.

Wether tackles these cases with great relish, since he likes nothing more than a challenge. His legal skills — and those of his handpicked staff — have allowed DeVries to navigate the dangerous legal waters of hiring out everything from mercenaries to high-priced "escorts." He oversees the handling of literally dozens of lawsuits and other legal issues that



crop up on a daily basis around DeVries operations, ensuring that the normal operations of the company aren't disrupted or threatened. He also arranges contacts and legal agreements that offer the best deal to DeVries while still remaining acceptable to clients and contractors alike.

Image: Christian Wether is tall and thin, with blandly attractive features. He usually wears finely tailored business suits along with a smug look that says he knows something everyone else doesn't. His hair is dark blond and thinning somewhat, giving him a high forehead that goes well with his icy blue eyes.

Roleplaying Notes: You party as hard as you work, and you enjoy the social scene available to you through DeVries. After a hard day at the office, you like to unwind with your OpNet pornography subscription, and on weekends, you typically go cruising for rough trade in the local parks. You also find time to keep up on various legal journals and read mystery novels, which you consider your secret vice.

Gear: Laptop computer, dog-eared copy of *The Maltese Falcon*, Glock 9mm, bottle of *Astroglide*

Nature: Thrillseeker

Allegiance: DeVries

Attributes: Strength 2, Dexterity 3, Stamina 3, Perception 4, Intelligence 4, Wits 4, Appearance 3, Manipulation 5, Charisma 4

Abilities: Academics 4 (Law), Awareness 2, Biz 3, Bureaucracy 3, Computer 3, Drive 2, Etiquette 2, Firearms 2, Intimidation 4 (Legal Bluster), Investigation 4, Linguistics 2, Might 1, Perform 2 (Acting), Rapport 3, Resistance 1, Streetwise 2, Style 3, Subterfuge 4

Backgrounds: Backing 4, Contacts 4, Resources 4
Willpower 7

DeVries Agents

Klaus "Totentanz" Kleisner

Background: There was a time when the man named Klaus Kleisner was a happy and well-adjusted engineer designing automobile chassis for Daimler-Benz. That time ended when he met a beautiful American woman named Erica Ellis. Ellis told Kleisner that she "wasn't dating," but the two spent a great deal of time together and over the space of several months she began staying most nights at his comfortable home outside of Munich. Kleisner fell in love with Ellis and then fell further, into obsession, as she seemed both to be dating him and maintaining an almost cruel aloofness that he found maddening. As time passed, Kleisner sensed that Ellis was lying to him more and more frequently, a possibility that haunted him even in his dreams. When he asked her if she had slept with any other men during the eight months they'd been seeing each other she replied, "Of course I have, four of them in fact, but I told you we weren't dating, so don't act so surprised." When she proceeded to give him the sticky details of her experiences with her other four bed-partners, Kleisner's gut twisted, and he vomited.

The unmitigated rage and sense of betrayal elicited by Ellis' casual announcement triggered the explosive eruption of Kleisner's M-R node. In that fraction of an instant, Kleisner turned off his emotions entirely and erected walls around his psyche that are nearly impenetrable. Now, as Totentanz, he is a shark in nova skin, swimming ceaselessly through the carnage and violence of combat because he suspects that if he stops, he'll drown in his own festering rage. Elites who have fought beside Totentanz hear his mantra over and over and know it well: "*Ich bin der Hammer, der Dolch, die Sichel, die alles niedermäht,*" which, roughly translated, means "I am the hammer, the dagger, the sickle that reaps."

Totentanz's speed and stealth make him a terrifying opponent. He can cover large tracts of ground and impale an opponent on his spears before his enemy even sees him. Through a combination of guerilla tactics and sheer physical superiority, Totentanz has racked up a score card of more nova kills than anyone else on the planet, a fact that makes him the object of a great deal of fear. It also makes him very marketable, and he is the most expensive elite available through DVNTS. Conveniently for DeVries, donning the dreaded skull-mask that is his trademark remains one of the few things that brings Totentanz pleasure.

When not on the battlefield, Kleisner follows an ascetic and almost compulsive regimen of physical training and meditation. He eschews any and all relationships, preferring solitude to the company of others. He reserves his true scorn and disdain for those who weaken themselves with junk food, cigarettes, alcohol or drugs, and he takes a particular enjoyment in killing those elites



whom he feels have weakened themselves by indulging in stupid and self-destructive baseline vices.

Kleisner is extremely professional in all his business dealings. He is punctual, cordial, and he listens attentively when given an assignment, but he has almost no interaction with others beyond taking assignments and training other Elites at the Windhoek base.

Because of his Germanic looks, judgmental nature and cold persona, Kleisner has been called a nazi more times than he can count. While he is extremely authoritarian, he is not a nazi. Kleisner hates only two groups: those he perceives to be decadent, weak or debauched, and those he is paid to hate. Political ideologies are, to him, moot.

Image: Klaus Kleisner epitomizes the Aryan ideal. He stands slightly over two meters tall, has close-cropped golden hair and blue eyes like ice caves. His features are angular and he has a square jaw that any male model would envy. Though his eyes constantly dart about looking for trouble, emotion never registers on Kleisner's face.

Roleplaying Notes: You are become Death, shatterer of worlds. A remorseless, killing machine, you stalk the world's battlefields, striking terror into the hearts of those unlucky enough to cross your path.

Gear: Spears, golden skull-mask (contains a data connection similar to the implant version but entirely external that includes full OpNet access), shaped charges, flash grenades

Nature: Somewhere between Bravo and Visionary

Allegiance: DeVries

Attributes: Strength 5, Dexterity 5, Stamina 5, Perception 4, Intelligence 5, Wits 5, Appearance 4, Manipulation 3, Charisma 3

Abilities: Academics 1, Athletics 3, Awareness 4, Command 4, Computer 1, Drive 2, Endurance 5, Etiquette 2,

Might 3, Firearms 4, Intrusion 4 (Electronic Infiltration), Intimidation 4, Interrogation 3, Investigation 1, Linguistics 2 (German, Afrikaans, English), Martial Arts 5, Medicine 1, Melee 5, Pilot 1, Rapport 1, Resistance 5, Science 1, Stealth 5, Streetwise 3, Style 1, Survival 5 (Tracking), Subterfuge 1

Backgrounds: Backing 4, Contacts 3, Eufiber 5, Node 2, Resources 5

Quantum 5, Quantum Pool 40, Willpower 10, Taint 1

Powers: Mega-Strength •• (Quantum Leap), Mega-Dexterity ••••• (Accuracy, Cat Footed, Rapid Strike) Mega-Stamina •• (Adaptability, Durability), Mega-Perception •• (Blindfighting, Bloodhound), Mega-Intelligence •• (Analyze Weakness, Mental Prodigy: Tactical), Mega-Wits •• (Quickness x 3, Enhanced Initiative), Disorient ••, Force Field •••••, Healing •••, Invisibility ••, Psychic Shield •••••, Quantum Leech ••••• (Extra: Energy Siphon), Quantum Regeneration ••

Joseph "Pursuer" Simms

Background: Joseph Simms had what he considered a simple military career. His father, a widower, had been a soldier. Living on his lonely Minnesota farm, the elder Simms impressed on his son the values of obedience, honor and duty. Joe had a penchant for sports, mechanics and hunting but not for his studies. After graduating in the bottom third of his high-school class, he enlisted in the Army. While not brilliant, Joe gained a reputation as disciplined and hard working. He drove a tank for 10 years before being promoted to sergeant, then drill-sergeant and finally to an instructor in the sniper training program.

As a graduation exercise, Joe's students were released into the wilderness to kill a dummy target. Their instructors, meanwhile, tried to "kill" them first. In March of 2000, three new snipers were lost in a blizzard in the Alaskan hills during the exercise. Search parties went out, but the storm forced most of them back inside. Joe knew his students would freeze in the sudden temperature drop if they weren't found quickly. He ignored his orders and pushed on. The snow grew thicker, and Joe started to develop frostbite on his toes and fingers. Eventually, he was too tired to continue and too far out to turn back. He thought he was going to succumb to the cold when quantum "ghosts" of two of the old hounds from his father's farm came bounding up out of the snow. They barked at him until he got up and, feeling remarkably better, found his three students and carried them back to the base single-handedly.

Everyone was surprised he didn't join the US Army's nova recruiting program, but in those cold winter moments when he quietly erupted, Joe got a taste of something he'd never had in his 27 years in the army: real danger. Fame was new, too, and so was serious money. Intoxicated, he signed on with DeVries; they offered him all three. He assumed the amoral mercenary demeanor readily, and though he's lost his family because of it, he



feels more alive than he's ever felt before. His wife left him; he sees his two daughters twice a year.

As Pursuer, Joe has gained worldwide popularity and fame for his determined, seemingly unstoppable ability to find his target. And his widely publicized stance that, though an elite, he'll never fight the US has won him admirers there. Pursuer fought for Nigeria in the Equatorial Wars and injured both Pele and Caestus Pax in the course of combat. Pax has a grudge against him now, which Pursuer finds highly unprofessional and equally inconvenient, but he's not worried; he's shown he can handle Pax, and DeVries takes care of its own.

To get away from it all, Pursuer spends his spare time on lavish vacations and big-game hunting with his dogs. He breeds German Shepherds and Rhodesian Ridgebacks as a hobby, and he can be found at international dog shows several times a year.

Image: Pursuer looks pretty much the same, no matter where you meet him. He wears tank tops, fatigues and boots and keeps his platinum-blond hair crew cut short. He has a scar down the right side of his face, a souvenir of his fight with T2M member Pele in sub-Saharan Africa. Some (Simms included) think it makes him look dashing. At photo shoots, he likes to bring a dog or two with him both for the companionship and to soften his gruff image.

Roleplaying Notes: You speak tersely but perk up when a dangerous assignment is being discussed. At those times, you fire off question after competent question, until in the end you nod and rub your jaw in satisfied anticipation. You're loyal to DeVries mostly out of complacency. It's just easier to let them find the jobs and take care of the money and other details.

Gear: Duffel bag, BFG, .50 Desert Eagle

Nature: Thrillseeker

Allegiance: DeVries

Attributes: Strength 4, Dexterity 4, Stamina 5, Perception 3, Intelligence 3, Wits 4, Appearance 2, Manipulation 3, Charisma 3

Abilities: Athletics 3, Awareness 2, Brawl 3, Command 2, Drive 3, Endurance 5, Engineering 1, Firearms 4, Interrogation 1, Intimidation 3, Investigation 2, Martial Arts 4, Melee 3, Might 4, Pilot 1, Resistance 5, Stealth 2, Streetwise 2, Survival 2

Backgrounds: Allies 3, Backing 3, Contacts 3, Influence 5, Resources 5

Quantum 5, Quantum Pool 32, Willpower 7, Taint 4 (Aberrant Eyes)

Powers: Mega-Strength •• (Crush), Mega-Stamina •••• (Adaptability, Hardbody, Resiliency), Mega-Dexterity •• (Accuracy), Mega-Perception •• (Bloodhound), Armor •••, Gravity Control •••• (Blast, Field, Flight, Shield), Healing ••

Linda "Lotus Infinite" Raphael

Background: Linda Raphael grew up as a diplomacy brat. Her extended family is old, wealthy and respected; she visits them at their manor outside of Buenos Aires at least once a year. Linda attended an international school in Washington, D.C., and went on to Columbia to study religion and international relations.

During her time there, though, Linda became more and more attracted to the study of Buddhism. Her interest was initially academic, reflecting on the differences between Tibetan, Southeast Asian and Japanese spirituality. But as she studied the religion, her respect for it grew. She took time off from her studies after her junior year to join a monastery, where she spent her days in soto Zen meditation and menial work. During that time, she entered a period of complete silence. She began fasting, consuming only water and small, infrequent meals of raw vegetables between fasts. After this went on for months, an elderly monk brought her out to the monastery garden that was overflowing with ripe vegetables. The monastery's kitchen was nearby, and the smells of freshly cooked food hung on the wind, taunting her.

"You will work here," he smiled, "until you transcend your body."

Linda tended the garden for two months. During that time, she maintained her ascetic diet, despite the temptation of steaming rice and fresh plums. After watching others eating fresh plums all summer long, she could not stand it anymore. She ran through the garden, picking and eating whatever she could, juice running down her face. Three bowls of rice followed the produce. She sat in the garden and put down her bowl. Her belly was painfully full. Tears streamed down her face. A wind blew on her neck. She erupted.

Image: Linda Raphael is a beautiful Hispanic woman. When she stands up straight, she is all of five feet tall. She wears simple, loose clothing and sandals when not



on assignment. DeVries has provided her with a plain white eufiber bodysuit to wear while working, which she compliments with various wooden masks she obtained in Lhasa and Thailand. Alternately serene and agitated, she spends nearly equal amounts of time in seclusion and exploring the world in all its vibrancy. She let her hair grow out from her monastery days but recently shaved it again when it developed a distracting tendency to blow in nonexistent winds.

Roleplaying Notes: You left the monastery, but the monastery has not left you. You believe you perform mercenary work for the experiences it gives you and meditate daily. Confused, you don't know what to make of your eruption. In some ways, you think it retards your understanding. But if you gained anything from gorging yourself, it was the knowledge that transcending yourself is not the same as repressing yourself; so you use your powers in the world and continue your quest for enlightenment. Your family prefers this arrangement.

Gear: Wooden masks

Nature: Explorer

Allegiance: Independent

Attributes: Strength 3, Dexterity 4, Stamina 3, Perception 3, Intelligence 4, Wits 3, Appearance 4, Manipulation 2, Charisma 3

Abilities: Academics 3, Athletics 1, Awareness 5, Bureaucracy 1, Command 1, Computer 2, Drive 2, Endurance 3, Etiquette 2, Intimidation 1, Linguistics 3, Martial Arts 1, Medicine 1, Perform 2, Resistance 3, Science 1, Streetwise 1, Style 4, Subterfuge 1

Backgrounds: Allies 2, Backing 3, Cipher 3, Eufiber 2, Influence 3, Node 2, Resources 1 (Donates it to the poor) Quantum 5, Quantum Pool 30, Willpower 9, Taint 4 (Hair blows in non-existent winds)

Powers: Mega-Dexterity •••• (Accuracy), Mega-

Stamina • (Regeneration), Mega-Wits •• (Enhanced Initiative x 3), Mega-Appearance • (Awe-Inspiring), Disintegration •••• (“Infinite Wind”), Elemental Mastery — Air ••••• (Crush, Imprison, Propel, Shield, Sphere), Premonition ••, Psychic Shield ••, Quantum Blast ••• (“Infinity Justifier”)

Constantina Zavinovich

Background: DeVries recruited Constantina Zavinovich as part of its effort to expand into non-combatant nova resources. The agency courted Zavinovich fiercely. As a painter and illustrator, she commanded international attention at several gallery openings. As a cartoonist, however, she had been arrested in China, the Ukraine, England and Israel.

Her work, regardless of her medium, is turgidly expressive. She does not hold with the view that combining art and politics ruins both; such sentiments, she feels, come from the privileged elite. DeVries and the public agree. As she likes to remind audiences at her lectures, she did not erupt in a rarified academic environment. Instead, she erupted while fleeing the Chinese police after postering a neighborhood with copies of her painting “Still Life with America.” She barely made it out of the country, and the story she related on OpNet combined with disseminated images of her work prompted a new round of international protests over China’s human rights record. Project Utopia offered her a job on the spot. She spat at their representative, calling them a greater repressive force than any two petty dictators combined.

DeVries contracted Zavinovich to create an animated series that promises to be wildly popular (based on last quarter’s consumer-interest research), a wild parody of Project Utopia, world politics and romance from the point of view of a Greek Orthodox missionary and a Peace Corps volunteer. Several countries are already threatening to ban it due to its explicit content. DeVries is confident that, with the right pressure, these countries will relent, and Utopia finds itself in the awkward position of promoting her human rights agenda. Meanwhile, Zavinovich finds days to travel the world and put the injustice she sees on canvas.

Image: Constantina Zavinovich wears a perpetual grin. It can twist into a sneer when she’s confronting torture and repression, but it never really fades except in sleep. Approximately 600 men and women can attest to that fact; Zavinovich exchanges lovers like she exchanges ideas. A tall and voluptuous brunette, she projects a vigorous, taunting intensity. She tends to wear vests with lots of pockets for various art supplies over a tank top and jeans.

Roleplaying Notes: Fight the Power!

Gear: Sketchbook, charcoal, condoms (ribbed for her pleasure)

Nature: Visionary

Allegiance: DeVries



Attributes: Strength 3, Dexterity 4, Stamina 4, Perception 4, Intelligence 2, Wits 5, Appearance 4, Manipulation 2, Charisma 3

Abilities: Athletics 2, Arts 4, Awareness 4, Biz 3, Brawl 2, Computer 2 (Graphics), Drive 3, Endurance 5, Intimidation 1, Linguistics 5 (Russian, Chinese, English, Greek, Hebrew), Perform 3, Rapport 3, Resistance 4, Style 4, Streetwise 5, Subterfuge 3, Survival 2,

Backgrounds: Allies 4, Attunement 4, Backing 3, Contacts 5, Influence 4, Resources 3

Quantum 3, Quantum Pool 26, Willpower 6, Taint 2

Powers: Mega-Strength •• (Quantum Leap), Mega-Perception •• (Analytic Taste/Touch, Electromagnetic Vision), Mega-Wits ••• (Artistic Genius, Natural Empath), Mega-Charisma ••• (Natural Agitator, Seductive), Holo •••

Chin "Tank" Chou-lat

Background: Tank is the elite name of Chin Chou-lat, a Mongolian one of DeVries' more resourceful recruiters found last year while on an adventure vacation. Once a textbook case of "India Syndrome," he was wooed away from his family's herding culture and illusions of godhood with the promise of wealth and international recognition. With a little work, DeVries was even able to convince him to change his original choice of code name, Genghis, to something less controversial to the Mongol government.

Tank still expects a certain kind of respect, though, and will endlessly regale others with the story of the divine confrontation with a yak that caused him to erupt. His ego is amusing, but after a little training, DeVries found him a useful elite for clients looking for a straightforward (and sometimes brutal) response to their problems. Tank has worked in a number of conflicts around

the world, and he relishes the opportunity to face other novos in combat.

Image: Tank is a big, broad-shouldered Mongolian man, looking every inch like his namesake. He has dark eyes, long black hair and is generally unshaven, with a small beard and moustache. He has an easy smile, showing yellowed teeth, and a booming laugh. He speaks somewhat broken English, and his favorite word appears to be "fuck". He usually wears military-style fatigues on and off duty, although he's been known to dress up for a night out on the town, with very amusing results.

Roleplaying Notes: You are a noble warrior of the steppes, a reincarnation of the Great Khan. You live to fight, to drink and to fuck, though not necessarily in that order. At times, you miss the reverence shown to you by your own people. But as your popularity has spread and your OpNet fansites have grown, you've discovered an all new form of worship. This pleases you.

Gear: Whipsword, railgun

Nature: Bravo

Allegiance: DeVries

Attributes: Strength 4, Dexterity 4, Stamina 5, Perception 2, Intelligence 2, Wits 2, Appearance 4, Manipulation 2, Charisma 3

Abilities: Athletics 2, Awareness 1, Brawl 3, Might 3, Command 1, Computer 1, Drive 2, Endurance 3, Engineering 2, Firearms 1, Intimidation 2, Linguistics 1 (Mongolian, English), Martial Arts 1, Resistance 3, Science 1, Streetwise 1, Style 2

Backgrounds: Attunement 2, Backing 2, Eufiber 1, Resources 2

Quantum 3, Quantum Pool 26, Willpower 4, Taint 3

Powers: Mega-Strength •••• (Shockwave), Mega-Dexterity •• (Accuracy), Mega-Stamina ••• (Resilience), Force Field ••



N
HOME

N!entertainment

N!terview

N! the news

N!sight

N!tre nous

N!ternet

N!tv

fun N! games

help!

awards

legal stuff

search

find!

N
contact us

N
the news

The Elite of the Elites

Although the DeVries Agency is by far the largest and best-known nova employment agency in the world, it is far from the only one. Since DeVries started in 1999, a number of similar agencies have sprung up around the world, each offering the services of its nova employees to customers able to meet its price.

In fact, many agencies have taken to serving as “clearinghouses” for nova employment; a nova might work for more than one agency as a freelance contractor, hiring out with whichever one has work at the time. This has led some agencies, like DeVries, to sign exclusive contracts with some of their nova employees, although many still prefer to remain free agents.

The other major elite agencies in the world got to where they are by focusing on a particular market niche. While DeVries manages to cover it all, from mercenaries to consultants to media, most other agencies keep themselves focused on their chosen field.

So, if you’re looking to hire the services of a nova in the near future — and you’re looking to get some competitive bids — here are some agencies you might contact:

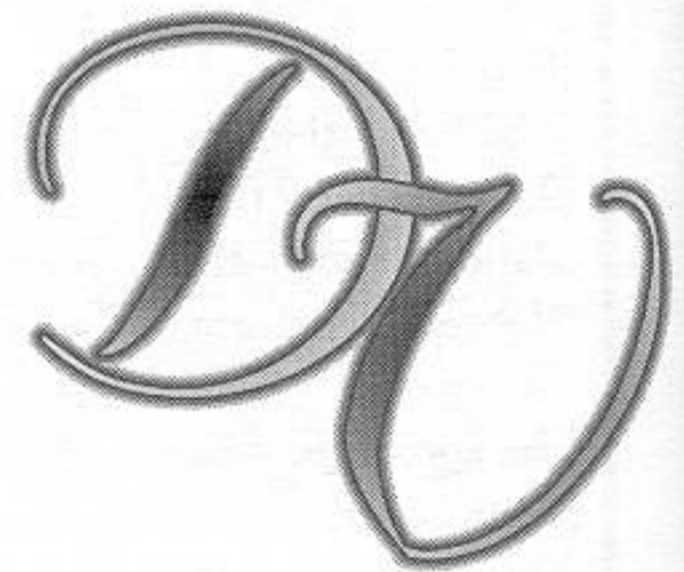

The Argus Agency

Founded by Scottish nova John Argyle, the Argus Agency’s motto is: “We’re there when you need us, whether you know it or not.” The agency’s claim to fame comes from Argyle’s own precognitive abilities, which erupted too late to save him from a car accident. The accident rendered him paraplegic, but also activated his M-R node. Argyle’s premonitions, combined with his formidable intelligence and organizational skills, allowed him to capitalize on places in the world where novas *would* be needed before the need arose. This allowed him to undercut DeVries on several major contracts when his company debuted in 2003, and brought the Argus Agency to the attention of employers around the world when its agents help prevent hundreds of deaths in the earthquake that shook the Philippines that year. Although DeVries filed a lawsuit claiming wrongful business practices against Argyle in 2006, the case was dismissed; the court said use of Argyle’s own nova abilities could not be considered “unfair practice.” Argus Agency novas are available for nearly any task, although the agency specializes in troubleshooting and emergency management.

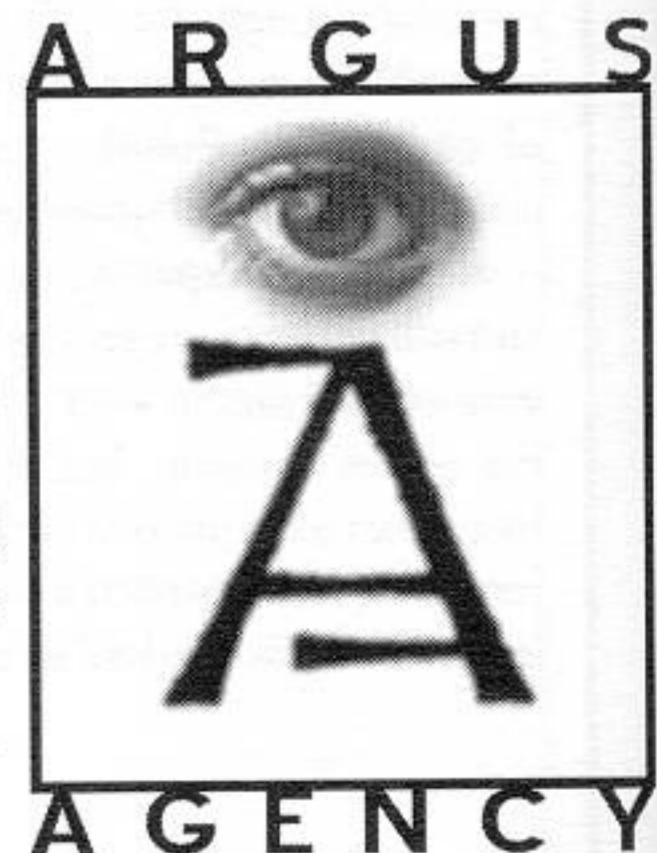

- N!ertainment**
- N!terview**
- N! the news**
- N!sight**
- N!tre nous**
- N!ternet**
- N!tv**
- fun N! games**

- help!**
- awards**
- legal stuff**

search

find!

Janissaries

This agency was started by Arabian business tycoon Rashid bin Muhammad al-Nasir in Abu Dhabi in the United Arab Emirates in 2000. Janissaries operates as a clearinghouse and agency for nova mercenaries worldwide. The majority of the company's elites are free agents who work on a per-contract basis, while Janissaries does have a small core group of elites holding exclusive contracts with them. "Someone has to fight DeVries' people," al-Nasir is once quoted as saying, and Janissaries has a reputation for working for the "underdog," as well as opposing DeVries novas in the field in areas like the Middle East, central Africa, Southeast Asia and South America. The agency also provides nova elites for security operations.



NovaCom

If you need information in this day and age, you generally turn to the OpNet. But if you can't find a particular piece of information, you could do a lot worse than turning to NovaCom, an elite agency specializing in intelligence gathering and information of all kinds, making it one of the premier nova investigations companies. NovaCom operates primarily on the OpNet, and its site — nova.com — provides potential customers with a complete description of its services and fees. The company employs a number of baseline information specialists and researchers, but for premium fees, it will put a nova on the case with abilities suited to the information you need to find. Need to dig obscure data out of the OpNet? A NovaCom agent can interface directly with their state-of-the-art computer systems to find it for you. Need surveillance work done? NovaCom elites with senses sharper than the best camera on the market will do it and even testify about it in court, if necessary.



Peacekeepers, Inc.

The world can be a dangerous place, and the Swiss-based Peacekeepers, Inc. recognizes that fact. "Security" is their watchword, and the agency specializes in a combination of security and protective measures, along with "an ounce of prevention," providing nova mediators and negotiators to help parties come to agreements and avoid conflict. Major corporations, political and religious organizations and national and local governments worldwide have employed Peacekeepers as mediators and protectors. Even the DeVries agency itself employed Peacekeepers when they were in need of third-party negotiation of a contract dispute with Novelty Consulting of Hong Kong.



An encrypted e-mail sent from svreeland@nova.com to jargyle@argusagency.com on 10/18/11

Mr. Argyle,

Here is the data you requested. Since your initial information was rather... well vague, to be honest, I can't be sure if this contains whatever it is you're looking for, but the files are as complete as possible, I assure you. We still have some feelers out looking for additional pieces of information, but since time is of the essence, we wanted to forward you the files we have so far. Review them at your leisure and let us know if there is any additional information or assistance you or the Argus Agency may require.

I would be most interested in hearing from you further about this matter, since it sounds like it could affect us all. I'd like to remind you of our company's reputation for discretion in sensitive matters like this one. We would be happy to provide further assistance at a discount rate. My people certainly found the job interesting. If you need help or you're ever looking for additional data recovery, please let us know.

Regards,

Samantha Vreeland

NovaCom

[files attached: 3512K]

[summary follows]

Peacekeepers Accept Security Job from Israeli Government

10/11/11: A representative of the Israeli government contacted Peacekeepers, Inc. regarding security arrangements for Prime Minister Ben-Shadrach's speech commemorating Palestine liberation, planned for 10/20/11. Peacekeepers forwarded acceptance of the contact to Israeli government later that day. An internal Peacekeepers' memo assigned handling of security operations to Mr. Illyich Buskin, an executive with Peacekeepers' offices in Bern, Switzerland.

Janissaries Contacted by Middle-Eastern Interests

10/16/11: Encrypted e-mail directed to Janissaries main offices in Abu Dhabi, United Arab Emirates from 173892472@anonservice.com (e-mail address no longer in service). E-mail offers Janissaries a contract for unspecified operations in the Palestine region on the date of Prime Minister Ben-Shadrach's speech. Janissaries responded with acceptance of the contract within two hours, contingent on further details from the employer.

Communication between Peacekeepers and Janissaries

Series of e-mails between Peacekeepers, Inc. and Janissaries from 10/16/11 through 10/17/11, specifically warning Janissaries to avoid the Palestine area within 72 hours prior to and following the evening of 10/20/11. Janissaries responded that they would respect Peacekeepers' wishes in this matter and avoid the area. Peacekeepers' source of information regarding Janissaries involvement remains unknown (believe me, it wasn't us, and I know it wasn't you).

Communication Between Project Utopia and Janissaries

10/17/11: Encrypted e-mail from Project Utopia nova-treatment facility in Bahrain sent to Janissaries in Abu Dhabi. E-mail provided rendezvous coordinates and time along the coast of Bahrain. No other information. Originating e-mail address purged from Bahrain facility's system immediately after send. Still, the sender must have possessed a high level of system clearance (real or hacked) to have set up the account and sent the message in the first place.

Janissaries Activity

As of 10/18/11: Janissaries' owned VTOL aircraft departed private airfield outside Abu Dhabi on 10/18/11 at 01:22:05 local time and took a course over the Persian Gulf toward Bahrain, flying below radar scans. No flight plan filed with air-traffic control. No information on passengers at this time. Aircraft returned to airfield 1 hour, 37 minutes later and was met by a motorcade of four vehicles registered to Janissaries. Three additional persons disembarked, including Zayid al-Shaali, arrested by Team Tomorrow on the Nigerois border in 08/22/11. Al-Shaali's glowing "fire halo" made his features clearly visible, but the remaining two figures have not yet been identified.

Peacekeepers Activity

As of 10/18/11: Peacekeepers field agents deployed in Palestine area under the direction of Georges "Aegis" Kapetelis, including three other known nova agents. Peacekeepers are implementing security measures for the Israeli Prime Minister and his staff. Status of Peacekeepers' surveillance of Janissaries unknown.

Israeli Activity

Mossad and Israeli armed forces providing supplemental security for the Prime Minister's appearance, with security checks of the site and planned route, backup routes and escape routes for the motorcade and a general increase in security measures along the Palestinian border.

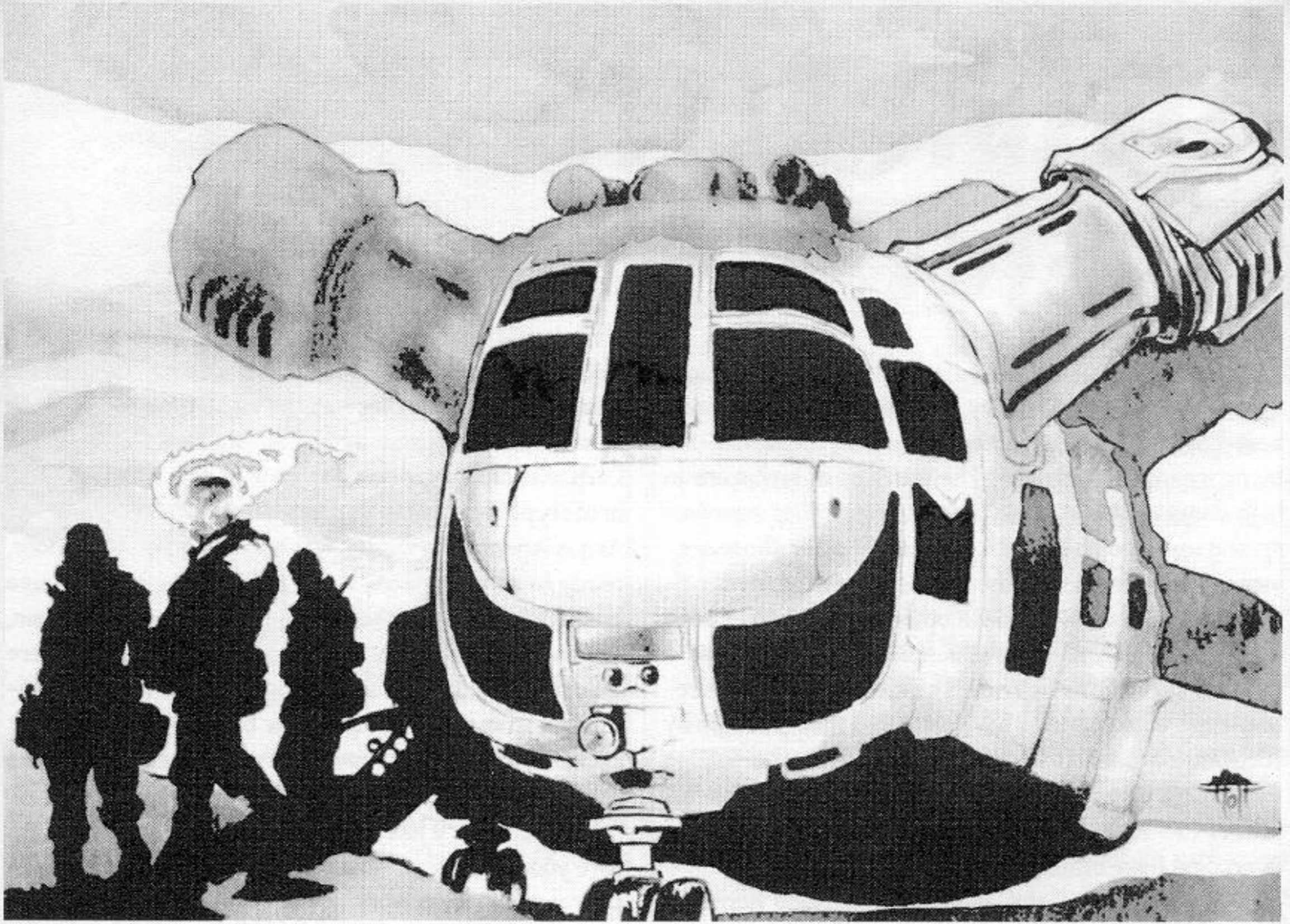

Conclusions

When you said something about "trouble in Palestine," you certainly nailed it on the head, Mr. Argyle. It seems clear the Janissaries are mounting some sort of covert operation, possibly with the assistance of Project Utopia (or elements within that organization). To what end, I cannot say, since the available data is not clear. However, it is possible the effort is intended to de-stabilize Israel or further damage Israeli/Palestinian relations, perhaps even make Utopia's efforts in the region seem like a failure (or to give Israel more reason to cooperate with Utopia in the future?). The Israelis' hiring of Peacekeepers fits in with their lack of native novas. Although rumors of secret Israeli nova-recruitment and -training programs continue to multiply on the OpNet, I can find no confirmation of them.

From: J. Argyle
To: P. Smallwood

Ms. Smallwood,
Please arrange a face-to-face meeting between our top covert operatives and myself immediately. Have Ms. Piedmont contact them personally and bring them here, pull them off current jobs if necessary, but do not tell them anything other than the fact that I want to see them immediately.

Also, contact Petr Matveev and tell him I'd like him to come here. Evie can provide transport, or he can make his own arrangements, but he needs to be here within three hours. If necessary, inform Mr. Matveev that the Directive owes us, and I'm calling in those debts.

Inform Mr. McCollough to institute full counter-surveillance measures immediately, and have the meeting room swept for any listening devices. I want Mr. Pak on hand as well, to provide the necessary psychic security, please see to it. I have a bad feeling about all of this.

— A.

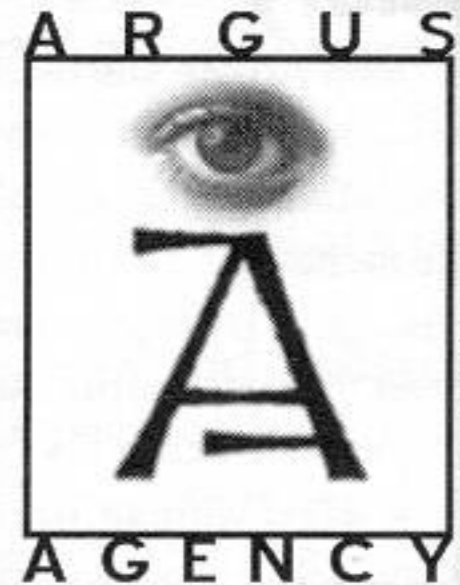

OTHER ELITE AGENCIES

Although DeVries is by far the largest, oldest and best-known nova employment agency in the world, it is by no means the only one. The services of novas are in high demand, and it wasn't long before other agencies sprang up to compete with DeVries to offer those services to customers with the means to pay for them.

Although many of these other agencies have been quite successful, none have achieved quite as broad a range of services as DeVries. The most successful "second-tier" elite agencies have attained their position by focusing on particular areas of expertise and setting themselves up as the premier agency in that arena, allowing them to effectively compete with DeVries and overcome their other competition.

While none of the agencies described here has been able to successfully challenge DeVries' domination of the elite market, it may only be a matter of time before one of them manages to do so. Storytellers can use these agencies as employers for elite characters or as a source of supporting characters and antagonists for **Aberrant** stories.

The Argus Agency

A visionary founded the Argus Agency — literally. John Argyle is a nova with the ability to see the future, and he doesn't often like what he sees.

History

John Argyle started the Argus Agency in order to cash-in on his own nova abilities, which gave him glimpses of the future. Unfortunately, he found it more difficult to make money off of foreseeing impending disasters than he thought. Trying to warn people beforehand usually proved fruitless; either Argyle had to tell them what he knew, in which case his "clients" were free to do what they wanted without paying him, or he had to try and bargain with clients for information they had no way of knowing about, which got him laughed out of more than a few meetings. Many of those would-be clients weren't laughing later on, but that did little for John Argyle's budding agency, which was wilting on the vine.

Argyle concluded that if he could not forewarn people of disaster, he could at least work to both minimize it and take advantage of it at the same time. He began the process of hiring novas to work for his agency and gained their respect by using his abilities to put his

people in the right place at the right time to get work as soon as it became available. Moments after Taiyo Corporation executives learned of the theft of their prototype and plans for the *Kaze* model flying car, Argus Agency personnel were knocking on their door, ready to offer their services and already holding some leads. When Cambodian-paid elites invaded Vietnam, Argus Agency novas already in Ho Chi Minh City were quickly able to reach an agreement with the Vietnamese government to defend their borders. A few similar opportunities quickly saw the Argus Agency leap onto the elite scene.

The agency has a reputation for being "there before you need them," and some people consider the appearance of novas working for the Argus Agency a bad omen, a sign that something bad is about to happen. Argyle takes full advantage of this dire reputation, since the appearance of Argus Agency personnel almost invariably draws plenty of media attention as well.

Executives

The CEO and director of the Argus Agency is John Argyle, the company's founder. His personal assistant is Ms. Penelope Smallwood, a brilliant organizer possessed of an iron determination that allows her to deal day-in and day-out with her boss's bluster and with talking from everyone from heads of state to powerful novas. Patrick McCollough is the company's head of security, and expert on security measures. He takes charge of security-related operations for clients as well as for the agency itself. The Argus Agency has a number of regional coordinators who handle business contacts in different parts of the world.

John Argyle

Background: John Argyle has always been a man who builds things. He was a successful contractor in Edinburgh and an avid jogger, a hobby that led to his current life. Argyle was running along a country road late one evening when a driver failed to see him and nearly killed him. As it was, the collision caused spinal damage, rendering Argyle paraplegic. It also caused his nova abilities to erupt, giving him the ability to foresee the future ("a few seconds too late," he often says). Argyle tried to make a fortune using his newfound abilities, but his premonitions always seemed limited to terrible or disastrous events. He couldn't accurately predict the stock market

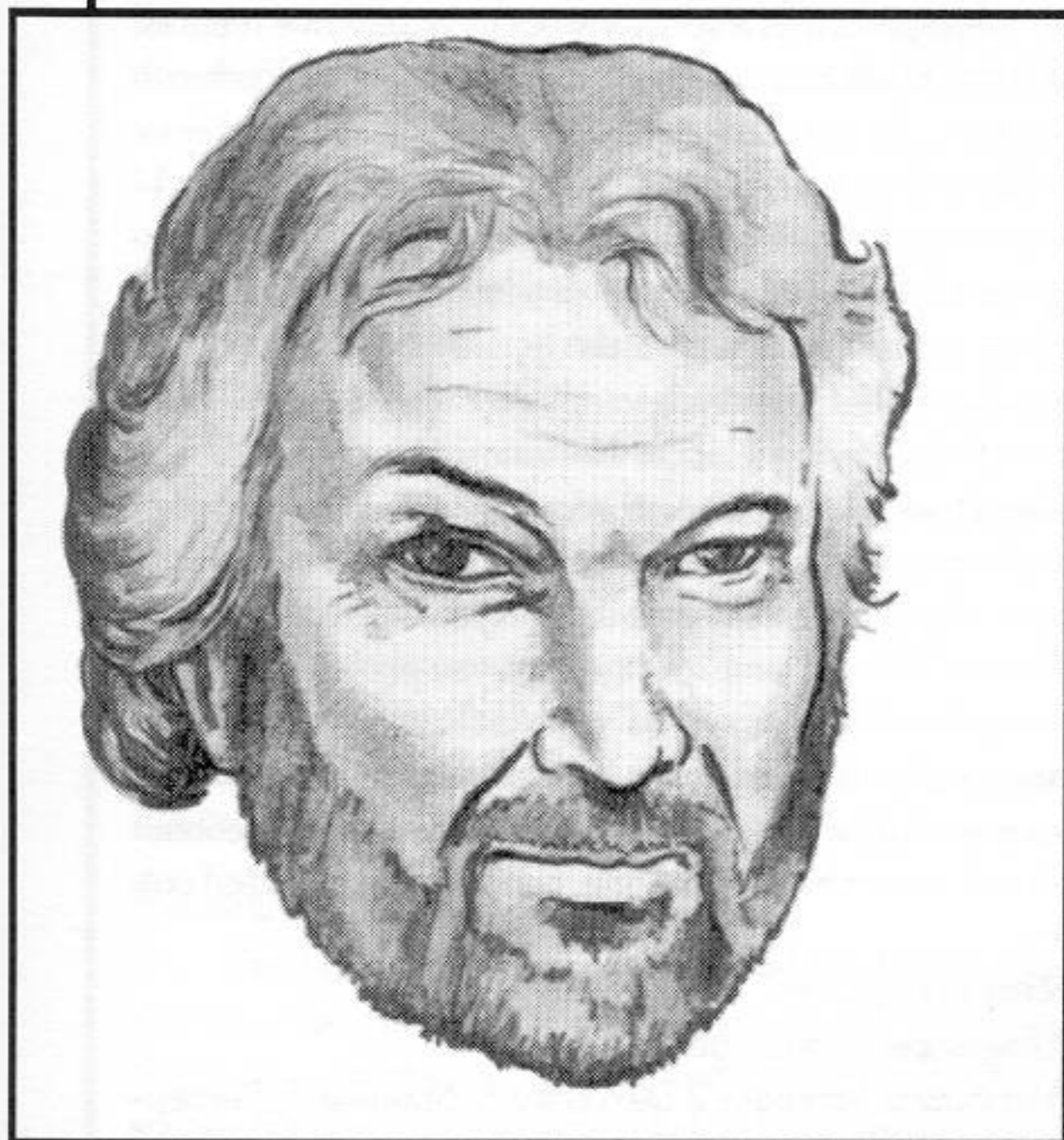

or lotteries or other things clients might be interested in, and his attempts to convince other people of his predictions of trouble were usually scoffed at, until it was too late.

So Argyle established the agency that bears his name and hired novas to be in the right place at the right time, as shown by his predictions. That gave the Argus Agency its reputation for quick response. He has since parlayed their initial successes into a network of contacts throughout the world, supplementing predictions with business savvy and a knowledge of what people want. Argyle has focused his whole life into running his agency. He does what he can to give the Argus Agency a reputation as altruistic, but he's still in business to make money, and now that he's had his spinal injury healed by a nova paraphysician, he's taking a more active hand in field operations as well.

Image: Argyle is a handsome Scotsman in his mid-40s, with brown hair going gray at the temples and a full, neatly trimmed beard. He typically wears sweaters or turtlenecks and jackets with patches at the elbows. He wears a kilt only on formal occasions (those that would ordinarily require him to wear a tuxedo, which he hates). He has a Scots brogue and a winning smile, that's known for charming the ladies.

Roleplaying Notes: You've spent your life trying to create something of lasting value. You have not done this by being brash or unthinking. You have a soothing presence that others appreciate and you use it to your best advantage, but you aren't out to rip anyone off. You know well that what goes around comes around.

Gear: 2 cell phones, latest newspaper, Colt .45 with hollow point bullets, extra cartridge of ammo

Nature: Architect

Allegiance: Argus Agency

Attributes: Strength 3, Dexterity 2, Stamina 3, Perception 4, Intelligence 3, Wits 3, Appearance 3, Manipulation 3, Charisma 3

Abilities: Athletics 2 (Running), Awareness 3, Biz 4 (Elites), Brawl 1, Bureaucracy 2 (Administration), Command 3, Computer 1, Endurance 3, Engineering 3 (Civil), Etiquette 3, Investigation 2, Resistance 3, Science 1 (Physics), Streetwise 2 (Black Ops), Style 2, Subterfuge 2.

Backgrounds: Backing: 5, Contacts 3, Influence 3, Resources 4

Quantum 4, Quantum Pool 28, Willpower 5, Taint 0

Powers: Mega-Perception • (Ultrapерipheral Perception), Mega-Charisma • (Commanding Presence), Luck ••, Premonition ••• (Others), Pretercognition ••••• (future only, bad and disastrous events only)

Clients

"You don't call the Argus Agency, it calls you," as the saying goes. Many of the Argus Agency's clients never even considered hiring them, until agency novas turned up on their doorstep and offered to help out with a problem only moments after it happened. Although there have been accusations of the Argus Agency creating problems for its agents to solve — a kind of "nova protection racket" — no one has been able to prove any wrongdoing on the agency's part, and most of its clients are perfectly satisfied with the service they've received.

The Agency handles a lot of "emergency management" cases, from theft and kidnapping to disaster relief and crisis management, all the way through invasions and assassination attempts. They also do investigation and security work, providing bodyguards and testing new security measures for clients.

Policies

Although the Argus Agency is a for-profit business, Mr. Argyle has made it clear to his employees that the protection of human life is more important than making money. In some cases, Argus employees have helped out in situations entirely *pro bono*. Cynics say the good publicity the company earns more than balances out any financial loss. Employees of the agency say they provide a valuable public service, without messing in politics like Project Utopia.

The agency requires a criminal background check on prospective employees, along with reasonably detailed personal information. It does not employ anyone currently in trouble with the law, but pretty much anyone else is okay, including novas with prior criminal records, Teragen sympathizers and so forth. So long as they follow the rules and don't cause trouble on company time, Argyle believes in giving everyone the benefit of the doubt and cares nothing for his employees' politics. Most employees believe Argyle himself protects the company from serious trouble. After all, if there was an imminent disaster about to affect his own company, he'd know about it, wouldn't he?

Personnel

Argus Agency novas are generally freelancers, working for the agency on a for-hire basis, and they're allowed to work for other agencies and employers, if they want. The agency does require a waiting period of at least 60 days before a client of the company can hire a nova on a permanent basis, but this hasn't proven to be a problem. The agency provides for all of a nova agent's needs while they are on-the-job, including insurance and medical expenses. The company has only a handful of full-time nova employees, including the famous Evie Piedmont.

Evie "Evac" Piedmont

Background: Evie Piedmont hails from England, where she was something of a rebellious teenager in the first years of the millennium. She traveled a great deal across most of Europe at the age of 18. While in Paris, she was stalked by street gang that chased her outside a Parisian club. Fleeing in fear of her life, and cornered in a dark alley, Evie erupted. The world seemed to slip out from under her, and she suddenly found herself in her bedroom at her parent's home in England.

Image: Evie is a spritely woman, barely five feet tall. She has black hair cut short, a small nose sprinkled with freckles and a broad mouth with a ready smile. Her figure is slim and athletic. She prefers "knockabout" clothes, T-shirts and shapeless sweaters or jackets, loose jeans, khakis or fatigues and her ever-present combat boots. She rarely wears jewelry or makeup, although her nails are usually painted (the shade varies according to her whims).

Roleplaying Notes: Nothing phases you. If you haven't seen it in your own personal life, in the course of work or in books, you've probably thought of it on your own. People typically describe you with words like "feisty," "fiery" and "perky," but you prefer to think of yourself as "well-traveled" and "eclectic." You love action, and your worst fear is becoming jaded. Luckily, your endless curiosity makes that an unlikely outcome.

Gear: Courier bag, cell phone, nail polish in assorted colors

Nature: Explorer

Allegiance: Argus Agency

Attributes: Strength 2 Dexterity 3, Stamina 2, Perception 4, Intelligence 3, Wits 4, Appearance 3, Manipulation 2, Charisma 3

Abilities: Academics 2 (Widely Read), Athletics 2, Awareness 2, Biz 1, Brawl 2, Endurance 3, Intrusion 3, Linguistics 3 (English, Dutch, French, German), Perform 2 (Dance), Rapport 3, Resistance 3, Stealth 2, Streetwise 2, Style 3, Subterfuge 2

Backgrounds: Attunement 5, Backing 3, Resources 2 Quantum 3, Quantum Pool 26, Willpower 5, Taint 0

Powers: Mega-Wits ••• (Lie Detector, Quickness, Synergy), Teleport •••• (Combat Teleport), Warp •••

Janissaries

The Janissaries are an up-and-coming nova agency with an emphasis on the sort of action most people expect from elites: bodyguard and security work, paramilitary operations and (occasionally) black ops.

History

Association with novas has become a status symbol for wealthy and powerful baselines. For Rashid al-Nasir, scion of a Saudi family that made its fortune in petroleum, it was a necessity. Al-Nasir has been fascinated by novas since they first made their appearance and has done everything possible to make himself a part of the "nova scene" using his considerable wealth and connections. A devout Muslim, al-Nasir subscribes to the Sunni religious belief that considers novas the chosen of Allah, gifted with special powers by the Creator, although his interest in novas seems to come more from their fame than any spiritual belief.

His wealth, connections and desire to bask in the novas' reflected limelight made al-Nasir a natural employer of novas. It began first with his bodyguards and progressed to nova "companions" paid to accompany Rashid to important functions or meetings or simply to



She quickly figured out she was a nova and began using her abilities to travel wherever she wanted. When her money ran low, she began hiring herself out as a "nova courier," able to transport things (and people) instantly. John Argyle heard about her and contacted her to come work for him, promising her plenty of opportunities to see the world and no lack of excitement. He's delivered on his promises so far, and Evie remains one of the agency's most loyal employees. She earned her nickname "Evac" during the conflict in Vietnam, when she used her abilities to evacuate civilians from the area where elite novas were fighting.

be seen with him on the town. Later, al-Nasir began arranging “introductions” between baselines and interested novas. As his reputation as the man to speak to in the Middle East about hiring novas grew, so did al-Nasir’s contacts. The DeVries Agency made him an offer to work for them as a recruiter and contact, but al-Nasir rejected them out of hand. He had no need to work for anyone. In fact, DeVries’ offer gave him an idea.

Rashid al-Nasir started his own nova employment agency, naming it after legendary warriors of Islamic history. At first, Janissaries focused on nova employment opportunities in the Middle East, Asia Minor and Eastern Europe, but the organization has grown quickly and now serves clients worldwide. Al-Nasir’s rivalry with the DeVries Agency has only grown over time, and clashes between Janissaries and DeVries elites are certain to grab media attention.

Executives

The CEO of Janissaries is Rashid bin Muhammad al-Nasir, the company’s founder and owner. He is assisted by a number of clerical and administrative personnel. His personal assistant is Fatima al-Kassim, a Saudi woman famous (or infamous) for her education abroad and her iron determination. Fatima runs much of the business side of Janissaries, allowing Rashid to attend to the more social aspects of the business.

Rashid bin Muhammad al-Nasir

Background: Rashid bin Muhammad al-Nasir was born into wealth and privilege and led a life of both opportunity and duty to his family and their business. He was raised in a Muslim household, following the traditions of Islam and Arabian culture, but he was also widely exposed to the ways of the Western world and educated abroad to better understand the people his family did business with. In his youth, he traveled extensively to Europe and North America, and he has long considered himself a “citizen of the world.”

When the first novas appeared, Rashid was already in charge of the family business, his father having retired in the early 90s. Al-Nasir was fascinated by the news reports of these people, with their amazing powers and abilities, appearing around the world. He spent considerable time glued to television broadcasts of the first novas and feverishly collected information from the Internet. He felt the hand of Fate in the appearance of these novas, and he knew the world would never be the same. The old world was changing, giving way to a new and exciting place, and Rashid wanted, needed, to be a part of it.

He used his money to cultivate contacts in the nova community. When parts of the Middle East were prepared to stone novas to death out of fear, Rashid al-Nasir saw their promise and offered them a safe haven. He ignored his critics and reveled in being a part of the new glitterati, even on the periphery. He’s never regretted his decision to start Janissaries, and he devotes a considerable amount of his time to the company, sometimes to the exclusion of his other business interests.

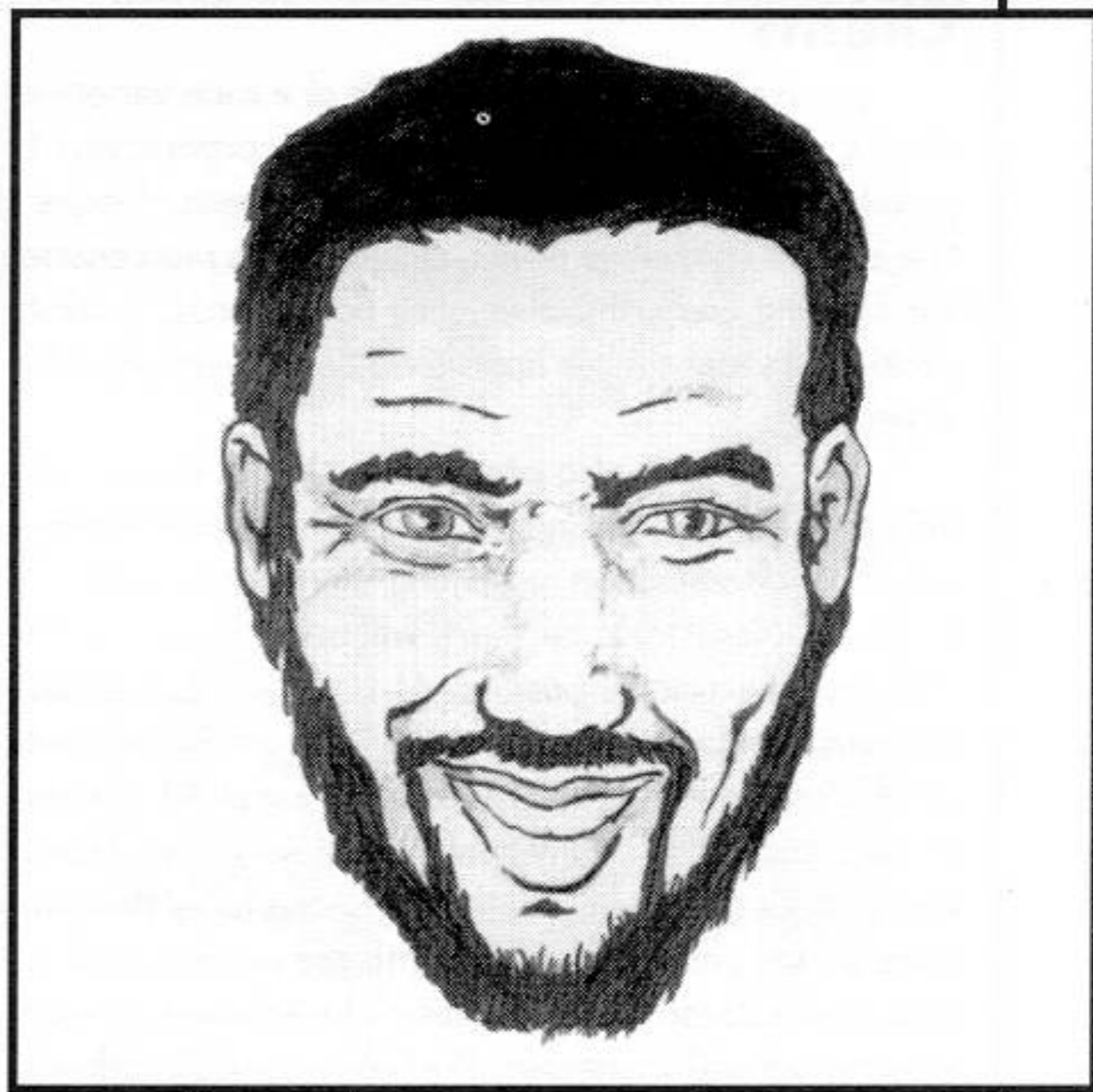

Running Janissaries is like being part of a grand drama for al-Nasir. Fortunately, his assistant Fatima al-Kassim helps keep him focused on the job at hand. Al-Nasir is disappointed that his wife Salma and al-Kassim do not get along (to put it lightly). Salma is jealous of al-Kassim and continually accuses her of trying to steal away her husband. Al-Kassim considers Salma a controlling shrew, best kept away from her husband’s business. He does his best to make peace, since his family is something he treasures greatly.

Image: Rashid al-Nasir is an Arab in his late 30s. He has jet-black hair and a full beard, kept neatly groomed. Laugh lines surround his dark eyes, and he smiles easily, showing perfect, white teeth. He normally wears light-colored suits, although he has an extensive wardrobe of business- and formalwear for every occasion. He wears the traditional garb of his people rarely, usually only for ceremonial occasions.

Roleplaying Notes: You love the spotlight. You love power. You resent that you are not a nova, but by controlling them, you satisfy your desire for quantum power.

Gear: Palm Pilot, watch with arrow that points toward Mecca

Nature: Gallant

Allegiance: Janissaries

Attributes: Strength 2, Dexterity 2, Stamina 3, Perception 3, Intelligence 3, Wits 4, Appearance 3, Manipulation 3, Charisma 4

Abilities: Academics 2, Athletics 2, Awareness 2, Biz 4, Command 3, Drive 1, Etiquette 4, Firearms 2 (Target Shooting), Intimidation 3, Investigation 2 (Research), Linguistics 2 (Arabic, English, Spanish), Rapport 3, Streetwise 3, Style 3 (Fashion), Subterfuge 3

Backgrounds: Backing 5, Contacts 3, Influence 3, Resources 5, Willpower 4

Clients

Janissaries caters to the needs of a wide variety of clients, from national governments to corporations to private individuals. The company's main areas of expertise involve combative novas, not just nova mercenaries for fighting wars, but also nova bodyguards, security consultants and similar operatives to prevent potential violence.

The company also provides — but does not publicly acknowledge — novas for black ops like kidnapping and assassination, assuming the price is right and Rashid al-Nasir feels the work will not compromise the company's security or position. Al-Nasir is known to have extensive contacts throughout the Middle East and Eastern Europe, putting Janissaries in an excellent position to work both sides of any conflict that may arise. Nearly every major government in the region has hired the company at one point or another, with the exception of Israel, which doesn't trust al-Nasir's hired novas, preferring to work with companies like DeVries and Peacekeepers when necessary.

Policies

Janissaries is run like a "temporary agency" for novas. The company has few permanent nova employees. Instead, interested novas submit their resumes to the company, and they are entered into the company's extensive database on nova elites. When a job opportunity appears, the company contacts the appropriately powered novas and offers them contracts on behalf of the client. The novas can either accept or refuse. This system keeps the company's overhead relatively low, while providing the largest potential pool of employees.

Janissaries does not have a policy against novas currently signed up with them accepting contracts from other agencies, but the practice of "moonlighting" is discouraged, particularly when it may lead to a conflict of interest. Nova employees are expected to refrain from taking on other contracts while working for Janissaries. There is something of a rift between novas working primarily for Janissaries and those who freelance more broadly for other agencies over "company loyalty."

One policy al-Nasir has made clear to his people: He does not work with novas with known Teragen ties or sympathies. Al-Nasir finds the Teragen philosophy divisive, but his real dislike of the group stems from an encounter with a Teragen nova who insulted al-Nasir by saying that a baseline like him should never have power over novas. That hit a bit too close to the mark of Rashid's secret desire to be a nova and his own need to control what he does not fully understand.

Personnel

Most of the personnel working for Janissaries are baseline employees. The company's nova employees are generally freelance operatives, who work on a per job basis. The company does have some "mainstay" novas

that work for it steadily, with others hiring on for only the occasional job here and there.

Ibrahim "Radi Khanjar" Farouk

Background: Ibrahim Farouk was born in war-torn Iraq in 1979. As a young man, he served as a soldier in the Iraqi military during the invasion of Kuwait and the Gulf War. He learned he had what he calls a "a talent for war." He survived the conflict of the Gulf War and hardships at home. While involved in a military training exercise, his nova abilities erupted, leading to the death of a fellow soldier. Farouk chose to flee Iraq to avoid the authorities, who wanted him arrested, and the army, which saw him as a kind of "secret weapon." He killed the soldiers sent to capture him and disappeared.

His escape took him to Saudi Arabia, where he made the acquaintance of Rashid al-Nasir. Al-Nasir offered Farouk a means to use his skills and his nova abilities, and Farouk accepted. He took the nova name Radi Khanjar, meaning "Black Dagger," and he prefers it to his given name, since it represents his "new life" as a nova elite.

Radi Khanjar has worked as an elite for several years, in places from the Middle East to Southeast Asia to Africa to South America. Everywhere he's gone, he's found his abilities in demand. This has only furthered Khanjar's belief that war is the primary occupation of the human species (novas included) and that being a soldier is the highest calling a man can have. His machismo covers up the hollow feelings of a man without a country, whose only purpose in life is fighting other people's wars for them.

Image: Radi Khanjar is an Iraqi man in his early 30s, with short black hair and a swarthy complexion. He often has a moustache or goatee, or at least a few days worth of stubble. He's of average height with a lithe, muscular build. He prefers dark clothing and usually wears military-style camo or fatigues in the field. He's fond of American-style rock-and-roll music and frequently has a small chip player and one or two chips on his person.

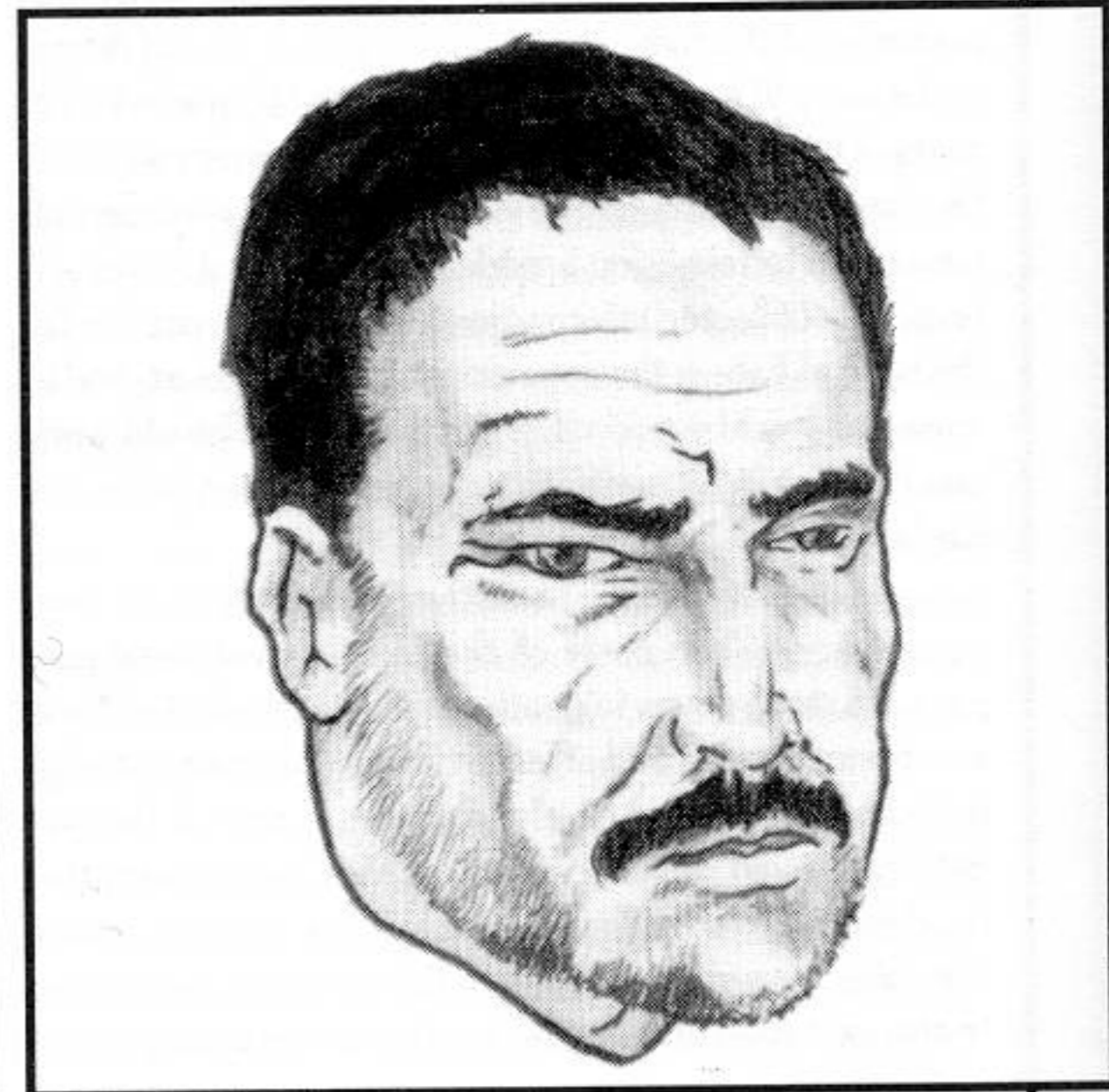

Roleplaying Notes: You have made the big time. All those things that were denied you in your childhood and youth are yours now, and the life of a mercenary satisfies you like nothing else. You just wish it weren't such a lonely life.

Gear: Chip player, chips

Nature: Bravo

Allegiance: Himself, or his current employer

Attributes: Strength 3, Dexterity 4, Stamina 4, Perception 3, Intelligence 2, Wits 3, Appearance 2, Manipulation 3, Charisma 2

Abilities: Athletics 3, Brawl 4, Bureaucracy 1 (Military), Command 2, Drive 2, Endurance 3, Firearms 4, Linguistics 1 (Arabic, English), Intimidation 3, Medicine 1 (First Aid), Melee 3, Might 2, Resistance 4, Stealth 2, Streetwise 2, Survival 2 (Desert)

Backgrounds: Contacts 2, Resources 3

Quantum 2, Quantum Pool 24, Willpower 4, Taint 1

Powers: Mega-Strength •• (Crush, Shockwave), Mega-Dexterity •• (Catfooted, Physical Prodigy), Mega-Stamina •• (Durability, Resiliency), Armor •••, Invisibility •, Psychic Shield •••

Zayid al-Shaali

Background: Zayid al-Shaali was born in Egypt and lived through the conflicts in the Middle East, although Egypt remained relatively peaceful. Deeply religious, he had thoughts about becoming a teacher of the *Koran*, but his poor family could not afford the costs of a private education. Al-Shaali was also known for his quick temper, which led him to choose a career in the military, hoping to earn a living and better his lot in life.

He succeeded for a time, although his temper made it difficult for him to advance in rank and resulted in disciplinary action more than once. Eventually, he found a way to make some extra money, by working with the black market and taking bribes. When he was caught, al-Shaali's temper got the better of him again, only this time it was more than just a good mad-on. The combination of fear, rage and adrenaline triggered al-Shaali's eruption into a nova.

He used his powers to escape, killing several soldiers in the process. Shortly thereafter, he began selling his services as an elite to the highest bidder. While working for the Nigerian government, al-Shaali was defeated and arrested by members of Team Tomorrow. The Nigerians denied having hired him, and Project Utopia took him to their Bahrain facility for detention. Project Proteus arranged his release, provided he would take on a mission for them, arranged through Janissaries. Never one to pass up an opportunity, he agreed.

Al-Shaali has a reputation as a dangerous opponent and an almost equally dangerous servant. His temper is legendary, and it's well known that he subscribes to the Sunni Muslim belief that nova powers are gifts from Allah. He considers himself something



of an avenging angel, an attitude given form by many of his powers.

Description: Zayid al-Shaali is a massive figure of a man, standing some 6'5" tall, with a broad, monstrously muscled chest and huge arms. His hair is shoulder length, and he has a short black beard. His head is constantly surrounded by a halo of fire generated by his powers, and his eyes burn with the fires of anger much of the time. When he flies, wings of fire appear to sprout from his back, and he can surround himself in an aura of flames. He usually wears para-military clothing in the field but frequently goes bare-chested.

Roleplaying Notes: Rage is your greatest blessing and your worst enemy. Your temper is the only constant in your life. Women, missions and friends all come and go, but your anger is always there for you. In social situations you are incessantly impatient; people are always too slow, too dumb and they're always in your way. You prefer life in the battlefield. At least out there if you lose your temper, no one is likely to press charges.

Gear: Copy of the Koran, garrote

Nature: Bravo

Allegiance: Himself or his current employer

Attributes: Strength 5, Dexterity 3, Stamina 4, Perception 2, Intelligence 2, Wits 3, Appearance 2, Manipulation 2, Charisma 3

Abilities: Athletics 3, Awareness 2, Biz 1 (Mercenary Work), Brawl 4, Command 1, Drive 1, Endurance 4, Firearms 3, Interrogation 2 (Torture), Intimidation 3, Melee 3, Might 4, Resistance 4, Stealth 1, Streetwise 3 (Black Market), Survival 2

Backgrounds: Attunement 1, Node 3, Resources 3
Quantum 4, Quantum Pool 28, Willpower 5, Taint 5 (bulging muscles, fiery halo)

Powers: Mega-Strength •••• (Lifter, Shockwave),

Mega-Stamina ••• (Durability, Hardbody, Resiliency), Flight (Fiery Wings) •••, Immolate (Flame) ••••, Invulnerability (Fire) ••, Quantum Bolt (Fire) •••

NovaCom

If knowledge is power, then NovaCom is one of the most powerful elite organizations in the world. Information is NovaCom's specialty. Whatever you want to know, its employees will find out, one way or another.

History

NovaCom got its start as the Bridgewater Systems Consulting Company in Massachusetts some 12 years ago. The company's original business was computer consulting services for a variety of corporate clients in and around the city of Boston. It was started by a brother-sister team, Darren and Samantha Vreeland. They combined Darren's brilliant computer engineering and programming skills with Samantha's considerable business savvy and personal charisma. Together, they turned Bridgewater into a competitive firm in the computer consulting shark-tank.

The company seemed to suffer a reversal of fortune when an explosion destroyed Darren's home, killing him and two other people. Samantha was hit hard by the loss of her brother, but she eventually rallied. Taking the money from Darren's life insurance, she restructured Bridgewater Systems, "to make it into a monument to all Darren worked for." She changed the company's focus to information and research services, changed the name to NovaCom and began looking into hiring novas.

Word about the new company spread quickly through the OpNet, and NovaCom established a reputation for being able to find out whatever it was clients needed to know, along with the discretion to keep those inquiries to themselves. It provided job opportunities for nova hackers looking for a challenge and found several interested in what it had to offer. Samantha Vreeland remains the CEO and director of the company, despite offers from companies like ViaSoft and DeVries to buy NovaCom from her.

Executives

Samantha Vreeland is NovaCom's majority shareholder and CEO. She's assisted by a skilled staff, including Vice-President of Public Relations Carter McManus, a smooth talker with a knack for handling the media. Vreeland's personal assistant is Rory Chambers, who is one of the few people in the company aware of the existence of NovaCom's "secret weapon," the nova hacker and computer expert known as Bug.

Samantha Vreeland

Background: Samantha Vreeland learned early on that if you wanted something, you had to go out and get it. She was always driven to succeed in life, a drive that earned her valedictorian of her high-school and college classes, a star spot on the track team, an MBA



from Stanford and pretty much anything else she wanted, so long as it wasn't an active social life or a lot of friends. Samantha tended to keep to herself. Her best friend was her brother Darren, and the two of them were a study in opposites, but both obsessive about their own areas of interest.

Samantha always looked after her little brother, and it seemed natural to her that she and Darren would go into business together. He was the technical genius, and she was the organizing and driving force, like she'd always been. Together they made Bridgewater Systems a success and they've worked together to make NovaCom an even bigger success. Samantha is one of the more influential people in nova circles these days, and she's pleased with all she's achieved. True, she hasn't had a serious relationship since college and nearly all her time is devoted to her work, but she's not concerned. She has NovaCom and she still has Darren, what else does she need?

Image: Samantha Vreeland is in her late 20s, with shoulder-length chestnut hair and green eyes. Her sense of fashion is quirky, and she often wears men's suits that she has tailored for her. She radiates an aura of confidence, even in the most difficult situations, and she commands respect from the people around her. She doesn't smile quickly or easily but, when she does, it's genuine and pleasant.

Roleplaying Notes: You're living the life you've always wanted. You love your work, and you find that your clients are almost inevitably fascinating. The only thing that bothers you is the absence of your brother or people asking too many questions about his disappearance.

Gear: Pocket watch, cell phone, Disney-Apple G10 laptop computer

Nature: Architect

Allegiance: NovaCom

Attributes: Strength 2, Dexterity 2, Stamina 2, Perception 3, Intelligence 3, Wits 4, Appearance 3, Manipulation 4, Charisma 2

Abilities: Academics 4 (Organization), Athletics 2 (Track), Awareness 3, Biz 4, Bureaucracy 3 (Administration), Command 2, Computer 2, Etiquette 3 (Diplomacy), Intimidation 2 (Veiled Threats), Investigation 3, Linguistics 2 (English, French, Spanish), Martial Arts 1 (Kickboxing), Streetwise 3 (Information), Subterfuge 3, Style 3

Backgrounds: Ally 2, Backing 5, Contacts 4, Resources 4, Willpower 5

Clients

A NovaCom client is anyone looking for information with the money to afford the company's fees and access to an OpNet connection. NovaCom's services don't come cheap, although simple research, conducted by baseline researchers and experts, is available from the company's extensive online database for simple access and bandwidth charges. Most clients, however, are interested in more detailed and harder to find information. They range from lawyers and angry spouses to heads of state, corporate executives and wealthy novas trying to get the drop on the competition.

The company's main area of business is finding and analyzing information of all types. Although they do a great deal of work via the OpNet, NovaCom employees are often out in the field in person, gathering information for clients. They do research, surveillance work, reconnaissance, even surveys, if that's what the client wants. NovaCom then compiles all the information into a comprehensive report for the client, usually delivered in electronic form, complete with hyperlinks and other user-friendly features. A hardcopy is also provided, if the customer requests it, but NovaCom prefers to deal with electronic media (as do most of its clients).

NovaCom also provides the computer consulting services that got the company started, particularly in the areas of information systems and security. Consultants assist clients in setting up security information and communications systems and checking existing systems for potential security risks and leaks. They test out client systems to ensure security, preparing a complete report of any flaws they find and how to fix them. Consequently, NovaCom has a great deal of information on how many of the top computer security systems in the world work.

Policies

NovaCom's number one policy is complete client confidentiality. All client information is kept secret and not given out to anyone. This includes the types of searches and information clients have requested. Although NovaCom could make considerable money selling its client database (and the company has received a number of lucrative offers), Samantha Vreeland knows full well the company's success is built on its

reputation for discretion as an impartial source of information. If clients didn't feel they could trust NovaCom to keep things quiet, they would look elsewhere for their information.

In order to maintain this reputation for secrecy, NovaCom has a sophisticated security system, particularly for its computers and digital archives. The finest security software runs on NovaCom systems (some of it designed by company programmers), and NovaCom employees keep careful watch for any signs of information leaks, which are plugged immediately. Thus far, no one has compromised NovaCom's systems, despite attempts by several parties, including ViaSoft and the Directive.

NovaCom also prides itself on its impartiality. NovaCom doesn't take sides in conflicts of any kind, political, economic or otherwise. The company's loyalty goes only as far as providing complete, factual information and ensuring customer anonymity. Other than that, NovaCom doesn't take interest in its customers' affairs, nor does it get involved in them. If one side of a conflict employs NovaCom to gather information, it'll do the same thing for the other side, without telling either one. The company's various clients live with this arrangement because NovaCom is a useful resource and because most are concerned about what the company may have about them stored in their archives. Nobody wants that information to become public knowledge, so it's in everyone's best interests to cooperate.

Personnel

In addition to a large clerical and support staff, NovaCom employs several dozen skilled computer programmers, researchers and engineers. The technical staff at the company is some of the best in the world, eager for the opportunities NovaCom offers for cutting-edge programming and 'Net research. The company also has contacts in nearly every informational field around the world. Many NovaCom jobs involve putting a client in touch with the appropriate expert and acting as a broker for a freelance contract between the two.

NovaCom primarily employs novas with information retrieval abilities. Cyberkinesis is a major power, but abilities like ESP, Pretercognition and Telepathy are not overlooked. Gathering information telepathically is a new field for NovaCom, still in its early stages, but holds a great deal of promise. The company also uses its nova resources well in concert, such as a telepathic nova acquiring the right passcodes so a programmer can access information over the OpNet.

Most of NovaCom's nova employees are freelancers, although the company does have some full-time novas on staff. NovaCom's "secret weapon" is a nova hacker who calls himself "Bug." Only the company's high-level executives know his existence, and only Samantha Vreeland knows that Bug is actually her "deceased" brother, Darren.

Darren "Bug" Vreeland

Background: Darren Vreeland was a brilliant computer programmer and researcher with a dangerous habit. In his spare time, Darren was a hacker, breaking into computer systems simply for the challenge and thrill of overcoming some of the best computer security in the world. Unfortunately for him, Darren stumbled upon information that certain people wanted very much to keep secret, enough that they were willing to kill him in order to do it. An explosion completely destroyed Darren Vreeland's condominium in Lexington, Massachusetts, leaving several bodies burned beyond recognition. The police presumed one of them was Vreeland himself.

They were incorrect. Darren Vreeland did die in the explosion that destroyed his home, but someone else was born in that same fiery blast. His M-R node activated by the threat of his imminent death, Darren escaped into the one place where he felt safe: the Net. His body transformed into pure energy, inhabiting the network itself. He's learned to modulate his energy, easily handling the transition from the Internet to the OpNet. The one thing he hasn't learned, however, is how to become flesh and blood again. His sister suspects he doesn't even want to any more.

After dealing with the Mafia family that tried to kill him — a series of mysterious "accidents" and anonymous e-mails to the FBI it was unable to trace — Darren began looking for a new challenge, something to do with his new life. He contacted his sister Samantha and together they came up with NovaCom, with Darren, known to others only as "Bug," as the company's secret info-weapon.

Image: Bug no longer has a human form. He's been known to appear on monitors and video screens as a stylized humanoid image dressed in elaborate hi-tech armor with an insect motif. He never shows his true (that is, former) human appearance to anyone other than Samantha. The fact that the world thinks Darren Vreeland

is dead is to his benefit for now. On those rare occasions when he leaves the OpNet, Bug looks like a vaguely humanoid figure composed of crackling, luminous energy.

Roleplaying Notes: You feel like Pinocchio. You used to be a stupid puppet but now you're a real boy. Or an unreal boy, as the case may be. Your meat-life is getting harder and harder to remember; when gigabits of information are coming at you every second, time passes much more quickly and memories from before your lightning life have faded like the pages from a cheap comic book. You still love your sister, although you're starting to think about moving on. The meat-world just isn't that interesting to you anymore. In conversation you're typically distracted, but that's because you're monitoring OpNet flow, and it tends to be much more interesting.

Gear: Anything he needs in the OpNet including armor, exotic weapons and comic props; none in the real world

Nature: Thrillseeker

Allegiance: NovaCom

Attributes: Strength 2, Dexterity 3, Stamina 2, Perception 4, Intelligence 5, Wits 4, Appearance 2, Manipulation 2, Charisma 2

Abilities: Academics 3, Biz 1, Bureaucracy 3 (Computer Systems), Computer 5, Drive 2, Engineering 4 (Computers), Endurance 3, Intrusion 4 (Electronic Infiltration), Investigation 4 (Research), Linguistics 3 (English, German, Japanese, Russian), Pilot 2, Resistance 3, Science 3

Backgrounds: Backing (NovaCom) 4, Cipher 4, Node 3, Resources 4

Quantum 5, Quantum Pool 30, Willpower 5, Taint 7 (Glow, Energy Emission, Permanent Power)

Powers: Mega-Intelligence ••• (Eidetic Memory, Mathematical Savant, Mental Prodigy: Engineering), Mega-Wits ••• (Multitasking), Bodymorph (Energy) •••••, Cyberkinesis •••••

Peacekeepers, Inc.

Through the efforts of novas like the members of Team Tomorrow, the 21st century is a safer and more secure world than ever before. However, the same nova powers have created new threats and new crimes that would not have been possible only a few short years ago. A single nova terrorist has the power to level a city block single-handedly, and there are concerns about even stranger things like nova "mind powers," control over machines and the very elements of nature. While most of the world trusts the novas of Team Tomorrow to keep them safe, others prefer additional security and turn to companies like Peacekeepers, Inc.

History

Peacekeepers, Inc. is a relative newcomer to the elite scene. The company got its start in 2005, during the crisis involving Macedonian dictator Yaroslav Radocani. The Macedonian situation made many nations and corporations around the world realize the potential

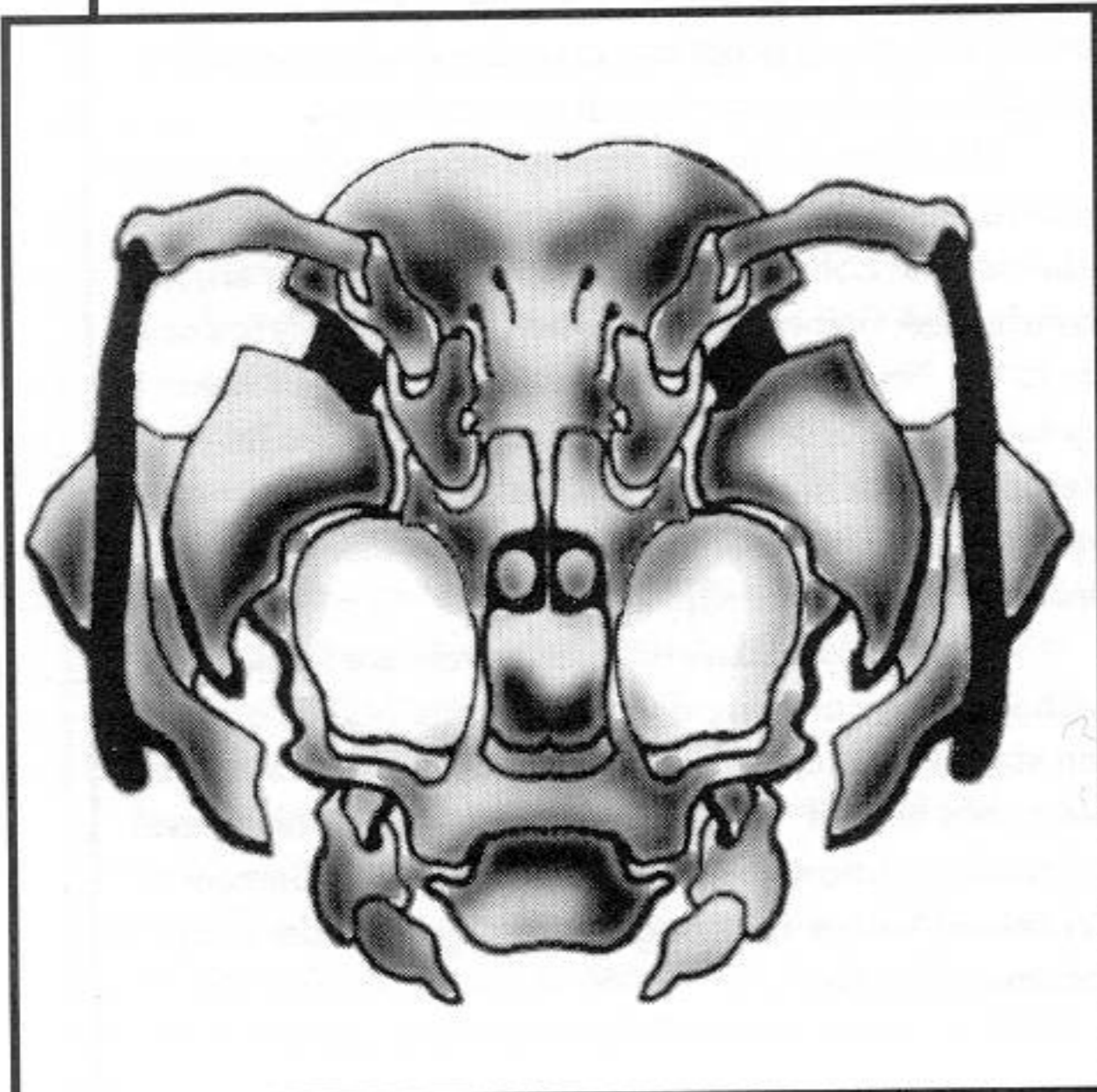

power of novas to affect security and military operations. It created a surge of popularity for Project Utopia and Team Tomorrow, along with renewed interest in the use of novas for security operations.

One of the people to take note of this was Madeline Dreyfuss, a businesswoman in Switzerland. Dreyfuss immediately placed her considerable wealth behind the creation of a new company aimed primarily at employing novas for security and defensive work throughout the world. In a matter of months, Peacekeepers, Inc. was offering everything from nova bodyguard services to comprehensive security systems and package deals.

The company's spokesman, Georges "Aegis" Kapetelis, scored a PR coup for Peacekeepers when his force field powers helped protect the newly elected President of Macedonia from an assassin apparently loyal to the Radocani regime. The incident showed up Team Tomorrow novas and brought Peacekeepers, Inc. to the attention of clients around the world. The company currently has security contracts with numerous governments and corporations and is aggressively recruiting new novas to fill the demand.

Executives

The woman behind the success of Peacekeepers is Madeline Dreyfuss. A Swiss citizen by birth, Dreyfuss parlayed her family's small banking fortune into a much larger one as an investment broker. She also enjoyed the social life of the continent and could be found at many of the "in" parties and gatherings. Over the past two years, Ms. Dreyfuss' social calendar has lightened considerably, as she devoted more time to maintaining the success of Peacekeepers, Inc. Those close to her say Dreyfuss has found a project that truly interests her, although for how long remains to be seen.

Dreyfuss is assisted in running Peacekeepers by a number of executives recruited from companies she has associated with in the past, both in Europe and North America. One of Peacekeepers' best-known faces is Phillipe LeChance, the company's Vice-President of Nova Relations and Peacekeepers' prime recruiter of new nova talent. LeChance closely follows information on the world's novas, particularly signs of new novas erupting. He follows up on any potential leads as soon as possible. Within 24 hours of their eruption, a new nova can plan on hearing from LeChance (along with a couple dozen other similar offers of employment).

Madeline Dreyfuss

Background: The only child of a Swiss banking family, Madeline Dreyfuss was born with a silver spoon in her mouth. That didn't keep her from wanting to make her own way in life, however, and she combined a keen intellect with an innate charm and a gift for finding interesting ways to spend her time. She was a very capable, although somewhat flighty, student, earning herself a degree in Business Administration but also keep-



ing her father up late at night with her exploits, late-night parties and romantic flings. Madeline had difficulty settling down, there was simply too much to see and do in life for her to be content with any one thing (or any one man, it seemed).

Madeline was fascinated with novas from the time they first appeared, and she availed herself of the family money and her own connections to infiltrate the nova scene from time to time, attending parties in Ibiza, Paris and Monte Carlo. She became romantically involved with a few different novas but nothing that lasted for very long. Over time, her association with the bright, shining, new stars of the social scene seemed to dampen Madeline's spirits somewhat. When the Macedonian crisis occurred, she watched it all in fascination. The very next day, she began making arrangements for the creation of Peacekeepers, Inc.

Although she does not talk about it in public, Madeline's experiences have shown her just how small and feeble a baseline can feel compared to a nova. None of her nova relationships lasted. Once the initial fascination wore off, it was hard not to feel inadequate next to someone who could party for days and still pick up a car with one hand afterward, to say nothing of a paramour who thought baselines and apes belonged in the same scale of intelligence. Madeline realized how threatened many baselines felt by novas and how much they needed protection against what novas could do. She became determined to master her feelings and become one of the people influencing the nova world, rather than being influenced by it.

Image: Madeline Dreyfuss is in her mid-30s, with blond hair cut quite short (although the style varies depending on her mood). She has blue eyes, a fine complexion and stays in excellent shape through a daily exercise routine. She normally dresses in casual business

attire, but her sense of style makes anything she wears a fashion statement, from a rumpled jogging suit to a designer evening gown.

Roleplaying Notes: High art. *Haute cuisine*. *Haute couture*. These things are your life. You were reared with a cultivated appreciation of the finest in human nature, and you seek it out. This includes spending time with beautiful, intelligent and powerful people, preferably novas. If it were possible to buy nova-dom, you would have done it years ago. Being a baseline frustrates you almost more than you can bear, but you hide it well. While you've learned not to condescend to those less fortunate, less cultured and less educated than you, there are times when boorishness cannot be endured and you assign a personal assistant to speak with others while you retreat to your very plush office to listen to Bach or Brahms.

Gear: Compact, lipstick, hand-held computer, cell phone

Nature: Gallant

Allegiance: Peacekeepers, Inc.

Attributes: Strength 2, Dexterity 3, Stamina 2, Perception 3, Intelligence 4, Wits 3, Appearance 4, Manipulation 3, Charisma 4

Abilities: Academics 2, Arts 1 (Writing), Athletics 2 (Equestrian), Awareness 2, Biz 3 (Financing), Bureaucracy 3, Computer 1, Endurance 2 (Sleep Loss), Etiquette 4, Investigation 3 (Questioning), Linguistics 3 (Swiss, English, German, Italian), Perform 2 (Dance), Rapport 4, Streetwise 1 (Nightlife), Style 3, Subterfuge 3

Backgrounds: Backing 5, Contacts 4, Influence 2, Resources 5

Willpower 6

Clients

Peacekeepers, Inc. provides security services for a variety of clients worldwide. The company's major clients are national governments, particularly those without the resources to recruit many novas of their own or in need of a supplement to their existing novas. Israel, for example, regularly employs Peacekeepers novas to bodyguard important government officials and provide additional security at important events. Municipalities or local governments also sometimes hire the company for security work. Peacekeepers is on retainer with the cities of Los Angeles and New York, for example. The Directive has also been known to employ Peacekeepers novas for more public security operations, not suited for the shadowy abilities of Directive novas.

Other major employers of Peacekeepers include corporations in need of additional security (or simply consultants versed in nova-security issues) and private individuals able to afford the company's fees. Corporations generally employ Peacekeepers for specific, sensitive operations or to investigate matters of industrial espionage and sabotage after the fact. Hiring a nova bodyguard is something of a status symbol among the

rich and powerful, and Peacekeepers does a brisk business hiring out such bodyguards.

Policies

One of Peacekeepers' most important policies is the company's devotion to peaceful missions. That's not to say that Peacekeepers novas don't see a lot of action (they do), but the company does not take offensive missions like many elites. Peacekeepers policy makes it clear that its personnel are not a private army for hire, more like a private police force. The company also makes every effort to cooperate with and conform to the laws of wherever it operates, particularly maintaining good relations with the local police force. Peacekeepers agents are taught to understand the law and their limits within it.

Peacekeepers requires background checks on all personnel, including novas. The company also requires full disclosure of personal information from its nova employees, although it does permit (even encourage) the wearing of distinctive costumes and masks, since they promote the image of novas as heroes in the public eye. The company prefers that the appearance and nova names of its employees be tasteful and non-offensive. Novas with unpleasant aberrations tend to be assigned to work behind the scenes, out of the public eye.

Personnel

The bulk of Peacekeepers personnel are support and clerical staff. The company also has specialized security consultants and trainers who educate company personnel as well as clients about security procedures and techniques. They are organized by Illyich Buskin, a Russian expatriate rumored to have ties with the old KGB. He's worked in the private sector as a security consultant for the past 20 years and is an old "friend" of Madeline's mother.

The company fields several hundred baseline security personnel, from security guards to investigators and bodyguards. The training of the low-level security personnel is comparable to that of police-academy training, while that of high-level personnel is equivalent to some of the best secret service and government-security personnel in the world. Buskin oversees the training and deployment of the baseline security personnel.

Finally, Peacekeepers employs around a dozen regular nova agents, along with numerous other freelancers. They prefer novas with defensive powers, particularly Mega-Stamina (and its associated enhancements), Armor, Force Field, Invulnerability and so forth. A nova bodyguard can take a bullet meant for a client and still be able to act. Healing is in-demand for emergency medics, and transport abilities like Flight, Hypermovement and Warp are useful for getting clients out of dangerous areas quickly.

The most prominent nova agent of Peacekeepers is Georges "Aegis" Kapetelis, a Greek nova and one of the company's first nova agents.

Georges "Aegis" Kapetelis

Background: Georges Kapetelis has seen some of the more difficult periods of his nation's history. Conflict in neighboring Albania and Macedonia often spilled over into northern Greece, where he grew up. He saw first hand the suffering caused by war and conflict written on the faces of refugees that came to Greece. Born in a sea-coast town, Georges fully expected to become a fisherman like his father, or perhaps to join the Navy. Before he could do either, his life changed forever.

Georges was working on his father's fishing boat when they ran afoul of smugglers bringing arms and other supplies into Albania. The smugglers planned to kill the fishermen and leave the boat adrift in order to avoid discovery. When he stepped forward to defend his father, Georges was chosen as the smuggler captain's first victim. Forced to his knees, a gun pressed against the back of his head, Georges heard the hammer cock back, the smugglers laughing at his imminent death, and he erupted. A glowing force field flared around him, deflecting the smuggler's bullet, a force wall protected the crew, and his force-field sheathed fists allowed Georges to make quick work of the smugglers.

Word spread quickly about the incident, and suddenly, Georges was flooded with offers of jobs, involving more money than he'd ever expected to make in his life. Any one of them would have improved his lot a thousand fold, but he quickly became overwhelmed by the sheer volume of opportunities presented to him, until Madeline Dreyfuss appeared. She took a personal interest in Georges and told him about the new company she

wanted to build, novas protecting people from harm. It wasn't as glamorous as some of the other offers were, but it was a chance to be part of something from the beginning. Georges accepted, and Madeline dubbed him "Aegis" after the legendary shield from Greek myth.

Not long after, Team Tomorrow liberated Macedonia, and Peacekeepers assisted the new Macedonian government. When Aegis saved the Macedonian president from an assassin's bullet, he became a media sensation overnight. He's been with Peacekeepers ever since, and he's completely loyal to Madeline and her company. In truth, Georges (who only recently turned 20) has a crush on the sophisticated and beautiful Ms. Dreyfuss, but he doesn't know how to express his feelings, and he feels she could never return them.

Image: Aegis is an attractive young man with a lean build, 5'11" tall. He has brown eyes that shine with an earnest sincerity, a shy smile and short, wavy black hair. He's become something of a clotheshorse since signing on with Peacekeepers. He spends a great deal of money on his wardrobe, trying to impress the ladies (particularly Madeline), but he doesn't quite carry off some of the outfits he chooses. When he's on duty, he wears a blue tunic with a white shield symbol over the right breast that buttons down the left side.

Roleplaying Notes: You enjoy being an elite. It's exciting, you get to travel and it pays extremely well. You are madly in love with Madeline, and everything you do is for her, but no matter how much you want to tell her, how badly your heart aches to touch her or how hard your libido pushes you, you cannot bring yourself to tell her. You have placed your boss on a pedestal so high you can barely speak to her without blushing. When interacting with others, you are very polite and a little goofy. Anything that doesn't have to do with Madeline or work is just background noise.

Gear: Cell phone, Binaca

Nature: Follower

Allegiance: Peacekeepers, Inc.

Attributes: Strength 3, Dexterity 3, Stamina 4, Perception 3, Intelligence 3, Wits 4, Appearance 4, Manipulation 2, Charisma 3

Abilities: Athletics 3 (Swimming), Awareness 3 (Keeping Watch), Brawl 3, Drive 2, Endurance 3, Etiquette 1, Firearms 2, Intimidation 2, Intrusion 2 (Countermeasures), Linguistics 1 (Greek, English), Medicine 1 (First Aid), Rapport 1, Resistance 3, Stealth 2, Streetwise 2

Backgrounds: Backing 3, Dormancy 2, Mentor 3, Resources 3

Quantum 4, Quantum Pool 28, Willpower 4, Taint 0

Powers: Mega-Stamina ••• (Adaptability, Durability), Mega-Intelligence •• (Tactical Prodigy), Force Field •••• (Extra: Wall)



Chapter Three: Elite Life

So You Want to Start an Agency

How To Get Yourself Into Trouble

In the brave new world of 2012, there are plenty of ways for a group of inexperienced novas to get themselves in trouble. Setting up their own elite agency is one of the best. If the players like the idea of seeing their characters become magnets for employment, adventure, intrigue and lots of potential danger, then this kind of series is an excellent option. Essentially, an agency is what results when a group of like-minded novas go into business for themselves, hiring out their own services or those of other novas to clients who have the cold, hard cash to pay for it. It's a more corporate, business-like route than the public-minded superheroics of antique comic books. The players can think of it as Superheroes, Inc., but with a competitive presence on the stock market. The commodity, of course, is the characters themselves.

This type of series is challenging. If the group affiliates itself instead with a government or organization (like Utopia), links up with some municipal entity (like a city or a national government) or hires itself out through a pre-existing nova placement agency (such as DeVries), a lot of its initial work is already done. If, instead, the characters decide to incorporate and strike out on their own, nobody is going to hand over free weapons, furnished living quarters or other convenient perks. The characters will have to start with whatever resources they already have and use their talents and creativity to make their own fortunes. Generally speaking, the world is ready to hand novas anything they want on a silver platter, but if characters choose to take the independent route, they'll have to go out and grab that shining plate themselves.

One advantage of this approach is that the characters can seek adventure while maintaining their independence. If they still feel uncertain about where their political allegiances lie — which would not be surprising, given the complicated balance of power in the world — then they may not be comfortable deciding to join Utopia (much less the Teragen). The characters may also decide they want more self-direction than they would have if they joined DeVries and that they do not want to tie their interests to the political agenda of a specific nation.

By incorporating, the characters have the freedom to choose where to establish their base, what kind of services to offer the world and how to target the people whom they hope will employ them. They have the power to accept or reject contracts as they appear and decide whom to affiliate with, retaining the freedom to alter their course down the line without finding themselves bound under a long-term contract to some powerful entity whom they really wouldn't want to piss off. It also provides the challenge of guiding a business they've created as it grows into a major new power in world affairs (assuming all goes well).

Finally, characters who establish their own corporation will enjoy the advantage that all good hard-boiled, trench-coated detectives have learned: They won't have to go out and look for adventure because adventure comes to their door. And, since they are novas and the world wants what they have to offer — *anything* they have to offer — adventure is guaranteed to show up.

An agency series is versatile and works with any of a wide range of moods. For instance, a group that decides to go into business for itself could set itself up along the lines of a traditional super-team: A team of novas might hire its members out (maybe only to "good" clients) or act as agents for others, and operate out of some urban HQ, stately old mansion or geosynchronous orbiting satellite (if they had enough Resources). On the other hand, such a group could also take a turn for the darker: think of the cynical, dangerous world of *Watchmen*, with its murky sense of mystery and pervasive feelings of corruption, nostalgia, sexual secrets and superheroes gone to seed. This might provide the mood for a series in which the characters aren't quite managing to be the kind of heroes they've read about in mainstream comic books.

If the players want something more hard-boiled, they could easily set up a business which "rents out" novas to solve crimes or investigate mysteries. The players and Storyteller should think of film noir and writers such as Dashiell Hammett and Raymond Chandler for inspiration; imagine novas ducking through the streets of Addis Ababa in eufiber trenchcoats and floppy fedoras. On the other hand, if the characters want to keep their options open, they might set themselves up as jacks-of-all-trades, running a kind of nova-style temp agency. The employees are likely to have many of the same complaints as any other temp — but the jobs they take are likely to be a lot more interesting.

Setting Up an Agency

The characters will need to consider several factors if they want to set up an agency. As with any business, there are practical details to consider. For instance, if they decide to establish a business that hires out novas' services to clients, they will need to make some choices. First, do they want to rent out their own services or act as agents for others? Second, what kind of corporate structure will they use to run the company? Third, what kind of services do they want to offer to the public, and whom do they want to convince to hire them?

Nuts and Bolts

Location, Location, Location

If the characters decide they want to set up in business for themselves, there are a few hoops they will have to jump through. It will add some verisimilitude to the game if the Storyteller makes the players plow through at least one or two bureaucratic obstacles. Depending on the level of realism the players want from the game — and the sadistic tendencies of the Storyteller — it would also be possible to spend several sessions simply setting up the organization. (An exciting, postmodern urban culture comes with its downsides, and one of them is city bureaucracy. Besides, this is a good starting point for characters to begin making local contacts; an ordinary trip to city hall can lead characters to new allies and an-

tagonists, political conflicts or intriguing rumors of conspiracy.)

The characters will have to decide where they want to open their business. On the one hand, they may already be settled in a city where they want to stay, or the Storyteller may have a specific milieu in mind. On the other hand, the players may have an entire planet to choose from. The world is a nova's oyster, and players need not limit their thinking due to matters of geography.

In the end, every location will have advantages and disadvantages, and the characters will have to decide what is most important to them. They cannot know everything about their new location until they get there, but they should pick somewhere that is interesting, busy and likely to provide an enjoyable setting for a series. They will almost certainly want to select an urban location, at least while starting out. Perhaps the characters have the goal of eventually constructing an orbiting satellite, but unless they establish a *pied-à-terre* in Delhi or New York as well, they will have a hard time interacting with the people they intend to serve. It's a rare nova who is able to set up shop out in the boonies and have clients come to her.

Once the characters have decided where they want to set up their agency, they will need to establish a foothold there and deal with the mundane tasks of beginning a business: finding a headquarters, publicizing themselves



to potential clients and similar necessities. This is a good time for characters to get to know their new environment: Life in Istanbul will be different from life in London, which will in turn be different from life in Tokyo, Stockholm or New York. If the Storyteller wants to do a little research on the city of choice, she can add a little local zest and authenticity to the atmosphere, giving the characters' home base a regional flare. A good Storyteller, or a group of players who are authenticity buffs, can use the opportunity to learn a great deal about the city of choice: A feel for the local architecture, history and culture can add great texture to the game as the characters navigate through their new environment.

Finding a Headquarters

Most businesses require a physical presence, and characters may need to rent or buy space in which to set up their headquarters. This space could be anything from a crumbling mansion to a corner suite in a shiny new office high rise. (Or, if the goal is a pulp-novel aura of seediness, it could be a dingy office in a back-alley tenement.) Perhaps the characters will live, work and run their operations out of these rooms; perhaps the office is just a place they commute to occasionally, and the real work goes on somewhere else. The Storyteller can allow the headquarters to simply fall into the players' laps, or she can march them through the process of locating and acquiring it. Developing a look and feel for the HQ can help the players and characters clarify the mood and tone of the series and can add much to the atmosphere. The HQ can also be understood to be a temporary one, which will change over time: A team might start out in a dull or nondescript HQ, and then, at the end of a particularly lucrative or attention-getting escapade, "graduate" up to a better one. As the team gains more experience, resources and fame, the players will also gain the freedom to let their imaginations run away with them. *Why shouldn't* the characters construct a translucent dome beneath the Pacific Ocean or a satellite headquarters in geosynchronous orbit over Berlin? The payoff will be far more gratifying if the Storyteller makes the characters start small and work with what they have at hand.

Kinds of Agencies

The nature of the characters' agency will be determined partly by the role they want to play — that is, whether they plan to hire out their own services or to remain behind the scenes and play the part of businesspersons. In either case, the characters should discuss with each other what sort of services they think they could offer: their abilities, the work they want to do and the needs of their target market. Following are a few basic company models, which can be modified to fit into series with different moods.

- The mercenary agency is a popular option. Being an elite is a high-profile profession, and nova combatants are in high demand around the globe. In this business model, characters hire themselves out, individually or as a team, to wage battles, fight other novas or conduct covert ops for clients. There are many possible angles for this kind of agency: On one end of the spectrum, the characters might become soldiers-for-hire in

the service of national governments, fighting border wars for money. At the other end of the ethical spectrum, the group could become an old-fashioned altruistic superhero team, fighting street crime and corruption or helping the government bust conspiracies, stop atrocities or end tyrannies around the world.

- The "protection and information," or P.I., agency. This euphemistically named private-client agency is proliferating in urban areas, as some novas realize that their talents are suited to more subtle challenges than fighting other novas. The nova agents of a P.I. business work with individual clients to take care of matters which require discretion: protection from enemies or the law, the recovery of stolen objects (or the "recovery" of objects whose ownership is disputed) and/or the obtainment of carefully hidden information — frequently the kind usable for blackmail and, sometimes, the kind which the legal authorities are holding against the client himself.

This type of agency is a 21st-century version of the old-fashioned P.I. — the private investigator. Although they rarely violate the law, technically speaking, novas who operate as P.I.s tend to operate in a world of moral ambiguities, maneuvering to stay far enough out of the authorities' sight to avoid conflict. There is at least one of these agencies in every major urban center, although only a select few will know where to find it; a nova P.I. and her low-profile teammates must know their city like the back of their hands and thrive on secrecy and danger. The city's underworld is likely to be aware of them, too. Like secret agents with no loyalty to anyone but themselves, P.I.s' lives often play out like a Raymond Chandler or Dashiell Hammett mystery — they are detectives in a neo-noir underworld. This kind of agency works extremely well for players who want a darker, hard-boiled and urban atmosphere in their series.

- The escort service. Officially, no nova escort services exist anywhere in the world... yet, but unofficially, rumor has it that a number of these very high-priced, very exclusive services are thriving. Certain individuals post to the OpNet about a call service supposedly run out of Damascus, serving the entire Middle East and Addis Ababa with quiet night-flying jets. Even more extravagant (and less believable) rumors suggest that a fabulous, corporate-sponsored cruise ship plies the international waters, inhabited by Mega-Attractive novas who love working in the sex industry and who specialize in pleasure. On the other hand, the OpNet contains considerable unofficial documentation by people who claim to have been to nova "play houses" in Hong Kong, Osaka, San Francisco, Istanbul, New York, Sao Paulo and Bangkok. Of course, the OpNet also contains unofficial documentation by those who claim to have had zero-G sex with flying cows, so most readers take play-house rumors with a large grain of salt.

Whether or not the rumors are true, their existence will tell a savvy entrepreneur that the public is interested in the idea. Characters might decide to found their own nova escort service — or even an in-house



agency (which was better known, in more puritanical days, as a “whorehouse”). The characters will have to research the applicable laws regarding professional sex in their area and apply appropriate levels of caution (or move elsewhere) — or, perhaps, find innovative new ways to get around those regulations. Then, they will need to do some subtle recruiting and even subtler publicity, and they are likely to find that business taking off.

Excerpted from the US Armed Forces’ general-issue brochure, *An Introduction To The Branches of the Services*, updated 3/14/08]

“The standard line is, if you gave [elite soldiers] a standard psychology test to see if they’re normal, they’d all flunk.... [Elites] are different psychologically and they’re proud of it. They have ways of looking at things and ways of putting things in perspective for themselves that would cause ‘normal’ people to throw up their hands.”

Captain Ron Yeaw, US Navy SEAL Special Forces

So You Want to Be A Mercenary

Of all the ways in which novas have changed global society, one of the most powerful has been their influence on the waging of war.

In simple terms, elites are super-powered soldiers who hire themselves out to do battle. Operating independently or under the management of an agent, they lease

their services to the highest bidder — usually, though not always, their clients are national governments or multinational organizations. Elites are occasionally sent on espionage missions, to assist (or command) entire armies, and sometimes, they *are* the battle: There have been international conflicts which have been waged entirely by novas. The Trans-Tanzanian Conflict of 2007 is one example. Another is the disastrous Kashmiri conflict of 2006, which left an entire region in environmental ruin. (Cf. *Aberrant*, p. 47, and *Aberrant: Year One*, pp. 27-28.)

Elitedom is an exciting and glamorous lifestyle, and if characters are good at it, it will make them internationally famous as well as stunningly wealthy. The profession has a dark side as well, perhaps more so than any of the other options a nova might choose from. Being a mercenary soldier is not like being a government spokesman, a Utopia agent, a city-sponsored crimefighter or even a super-powered wrestler who engages weekly in blow-out battles before the adoring public and the cameras of N!

Many a young nova — just like any other kid who joins the army to seek adventure and excitement — has the illusion that being paid to fight abroad will be one big, four-color adventure, like pro wrestling writ large. It isn’t. Players and Storytellers alike should keep in mind this simple truth: What elites really do is sign themselves out to wage war. And, as the saying goes, war is hell.

Although elites have only been around since 1999, the role they fill in world politics is really very, very old: the warrior who fights in the service of a government not her own, for pay instead of for patriotism. Mercenaries have been around for centuries, from the Grand Catalan Company who fought for the Byzantine Empire to the 14th-century Free Companies of France, Spain and Italy. Global popular culture still remembers the famous Swiss Guard and French Foreign Legion and the troops of white mercenaries who took part in bloody 20th-century conflicts in Africa.

But elites have suddenly made the mercenary profession both visible and glamorous, elevating it to a high-profile status it hasn't seen in centuries. Around the world, entertainment media loves to dwell on the "exploits" of high-profile elites like Totentanz or Lance "Stone Badass" Stryker, and N! follows their careers with as much enthusiasm as it does those of XWF wrestlers like Duke "Core" Baron, T2M members like Skew or singer/entertainers like Alejandra. Some observers of popular culture have commented on this almost schizophrenic combination: the massive public enthusiasm for these icons on one hand and the stark reality of their profession — killing people for pay — on the other. Of course, as others have pointed out, maybe there is a disjunction between elites' popularity and the harsh reality behind them.

In a nutshell, this schizophrenia is the core factor which both players and Storyteller will have to bear in mind when playing an elite series. The mercenary lifestyle is exciting and will probably bring the characters money, fame, travel and plenty of action. It might even bring them glory. But it is neither fun nor glamorous. Often, it's even sort of dull.

The players and Storyteller will need to agree on the level of authenticity they want to maintain in a series of this kind. Players who are interested in wargaming, or who like military recreation and history, might well want to keep close to the down-and-dirty feel of things. For a series like that, the Storyteller might try to recreate the authentically grimy, unpleasant setting of an African or South Asian conflict, letting the characters get rained on, isolated in damp jungles, eaten alive by insects and possibly faced with horrific and unexpected ethical conflicts. A "war" series of this kind could use models like *Apocalypse Now* or *Catch-22*. If the players prefer something more black-and-white, with clear-cut good guys and bad guys, then the Storyteller may choose to gloss over some of the realities of warfare — imagine something along the lines of the ever-romanticized French Foreign Legion, with all its exotic hardships and windblown drama, transplanted to a futuristic border war. In the end, it's probably a good idea to bear in mind something as simple but effective as the aesthetic of *M*A*S*H*.



The lesson war-bound roleplayers can learn from M*A*S*H is this: Fictional involvement in war doesn't all have to be terror and boredom — it can be exciting, dramatic and even a lot of fun. But when characters are in the middle of having grand old times conducting a border war, the Storyteller should remember to inject a few moments of sobering reality. War inevitably has its casualties.

Getting Into the Business

“We are Family”: Contracted Elites vs. Independent Players

Most elites operate one of two ways: independently (that is, as self-directed free agents) or under contract to a larger corporation. If the players decide that they want to play a series in which the entire group of characters will fight together, the characters already have an unusual commodity on their hands: The idea of an entire team of novas hiring itself out for battle missions is, in itself, a fairly odd concept. It is also relatively easy to get the group international attention when they announce their intentions.

If the characters go the independent route, they can meld the group into a self-determining team of warriors, establish their own private business and contract themselves out to employers. For more details on self-incorporation, see the section on “Starting an Agency” above. This choice has advantages: The characters will maintain their independence instead of signing it over to a managing agent. The team will be able to negotiate its own contracts and, essentially, control the direction of its own future. The characters also won't feel that they are giving up any of their power to others. They may feel that this means they are less likely to be deceived or manipulated by shady clients (however, this might not be a rock-solid assumption; see the section on “Information Fog,” below).

Remaining independent also has significant disadvantages. A managing agency takes care of many details for its employees; on an independent team, the characters must go through all the trouble of getting themselves into business. There will be bureaucracy to plow through, media attention to handle, PR spin to control, potential clients to solicit and screen — generally speaking, the characters will have to undergo the often painful learning curve of figuring out how to manage themselves as a team. There is also an art to negotiating with clients. (The characters may wind up in negotiations with experienced diplomats who work on a level of national or global authority. Mega-Intelligence or Mega-Charisma can make a nova a better dealmaker, but a baseline career diplomat with years of experience can often outmaneuver an inexperienced nova with surprising ease. No matter how great her skill at kicking in heads or turning people into ash, a nova character may find herself embarrassingly outclassed in the meeting room.)

Characters who want to become independent elites will have to figure out the mercenary trade on their own. Mercenary work is a complicated business, requiring skill with diplomacy, negotiation, battle strategy and the use

of military-caliber weapons and vehicles — and that's before characters ever reach the point of engaging the enemy. It will help if some characters have backgrounds in espionage, diplomacy or related fields.

A smoother way to leap into the mercenary biz is for the characters to hire themselves out as agents to a parent corporation. There are several agencies in the world that handle nova mercenaries, but by far the most highly-respected — and, according to rumor, highest-paying — elite contractor is the ubiquitous DeVries Agency. DeVries provides handlers, managers, subcontractors and general behind-the-scenes lookout for such high-profile elites as Pursuer, Lotus Infinite and Totentanz himself.

If the players decide they want to jump on board a mercenary corporation, their goal will probably be DeVries. The kind of money, technology, contacts, backup power, training programs and sheer prestige commanded by DeVries simply can't be found anywhere else. (Besides this, the global presence and sleek, unbroachable media presence maintained by DeVries make it by far the *sexiest* corporation on the planet.)

As everyone who watches N! knows, most elites tend to operate — that is, to fight — independently, whether or not they're handled by a managing corporation. Therefore, if the players want their characters to work together as a team, the characters will have to be sure to stipulate that point in the contract they negotiate with their employer — whether that employer is a handling organization or an individual client with a task for them. It may pay off for the characters to plan together ahead of time, constructing an “all for one” image which they can present to the media and to their potential employers. If they can point out the strengths and benefits which they'll have working as a team, they may be able to convince their potential clients, or their interviewers at a management agency, of the advantages which they can bring to the table. If they are able to demonstrate the benefits this will bring — in terms of both military might and PR perception — then they may be able to command even more from their employer than they would individually.

However, if the characters fail to think this through (or if the Storyteller wants to make things hard on them), then interviewers or clients may be skeptical of their desire to work together, expressing doubts that a still-untried team of novas could function together efficiently. In this situation, the characters will need to bring their best social engineering or diplomatic skills to bear. But beware: Some potential employers, like a DeVries interviewer or government representative, will be very familiar with nova social-manipulation tricks. A savvy interviewer might be impressed by a successful manipulation attempt — or the attempt might undermine the characters' chances completely.

Public Image: To Mask or Not to Mask

Once the characters have established their basic business strategy — either as independent elites or as contracted fighters for an elite-handling agency — it is time

for them to get to work on some other details. There is a lot to be done between the moment a would-be elite signs his contract papers and the moment when he is actually air-dropped into his first jungle (or mountain or ocean or desert) base.

One important task, which the characters may not have considered, is that of coming up with a public image. Public-relations management is a significant professional responsibility for an elite, and its complexity should not be underestimated. If the characters have signed up with DeVries or a similar agency, and if they are beginning as unknowns, then the corporation's publicity department will probably take on the task of handling their public personas.

A PR team does not simply "manage" the images of the elites in its care; it creates those images. A good publicity department is likely to relish the rare challenge of designing public images for an entire team of promising young novas. If the characters decide they want to take on public "personas" as elites — to create new personalities, whether or not they wear masks — then players can easily spend part of a session engaging in an odd but entertaining bit of meta-roleplaying. The characters they created will now create new characters within the game, which the characters themselves will roleplay, for the public's benefit. If the characters are operating independently instead of with a larger agency, they will still have to think about the image with which they will try to impress the public and their clients. They might hire a public-relations consultant or an advertising firm to help them handle this.

Being an elite includes a surprising amount of performance art. There are many levels at which a character can choose to "perform" the role, and characters should consider how complex a fiction they want to construct. Do the characters want to put on masks when they fight as elites, taking on entirely new public personas (like Totentanz)? Do they want to remain unmasked and open about their identities, but use "fighting" names or taglines (like Lance "Stone Badass" Stryker or Pursuer)? Or do they prefer not to bother with inventing a persona at all, letting their real name and appearance become associated with mercenary work (like Marissa Dunlop)?

Moreover, if the characters plan to work together as a team, they may decide they need to come up with a team name or general theme in order to make them stand out — and stand together — in the public eye. This is especially true for a team operating independently of a managing agency. Characters may find that it is difficult to come up with a team concept that doesn't seem hopelessly cheesy, but the more memorable their name and slogan, the more readily the public will latch onto them. (One important point to remember: If characters are operating independently and decide to wear masks and/or costumes, they will have to find a contractor who can make them properly, otherwise the characters may wind up looking as if their parents made their costumes for a Halloween party, and the other mercenaries will laugh at them.)

An example of a "handling" situation which brings publicists into conflict with the novas they're grooming:

Clarice Somerset, Deepak Banerjee, Ang Martino and their three companions have hired a highly respected publicity firm to help them kick-start their careers as independent elites. Since the characters have decided that they'll work together as a team whenever possible, the enthusiastic publicists have designed a theme and "look" for them, giving each a persona based on a planet of the solar system and the Greek deity associated with it. While the novas find the costumes and the schtick a bit cheesy, they are generally happy with their new personas. Three of them have complaints. Deepak is primarily a cyberkinetic, and it annoys him that his "persona" as the messenger god Mercury draws attention mostly to his super-speed — an ability he uses only occasionally. Ang, a time-stopper, is amused by his new persona as the god Saturn, but it irritates him that the handlers insist on a "clean" image for the team. Afraid that a single compromising photo could tarnish the team's budding popularity in the teen-magazine sector, Ang's handlers have been urging him to abandon the life he's enjoyed since before his eruption: spending the evenings playing with baseline women, with whom he's always liked a little consensual rough play.

On the third hand, the Mega-Attractive Clarice is frustrated by her new "assignment" as Venus, the goddess of love — an image which has little to do with her combat specialty as a firestormer, but which the handlers tell her will sell the team to the public, especially if she wears the skimpy costume they've designed for her. Moreover, because they are relying on her sex appeal to promote the team, the handlers are unwilling to let her talk publicly about her lesbianism. They tell her that if she wishes to say instead that she's bisexual, her approval ratings will jump, but Clarice is unwilling to exploit her sexuality in this way. For now, Clarice keeps up her cheerful demeanor, wears her low-cut bodice and spike-heeled boots to interviews, keeps her sexuality under wraps — and simmers with growing frustration and anger.

Characters who have contracted with a firm like DeVries, or who are retaining a PR consultant, should expect to find themselves "managed" as their handlers prep them for entry into the spotlight world of elites. This can be an unsettling experience. Think about it this way: In the golden days of film, say the 1930s through the 1950s, Hollywood film studios "managed" their stars, not only restricting what the public knew about them but also trying to control their private lives. Studios groomed their actors to present certain images: a sexy "bad girl" for Greta Garbo, a dashing lady-killer for Ramon Novarro, a charming bachelor for Cary Grant. By controlling the information that reached the public and setting up staged "romances" — or even arranging marriages — among the stars, the managers covered up their human foibles: The news of a star's drug abuse, violent brawling, adulterous affairs or alternative sexuality was suppressed before it reached the public's ears. (All of the actors just named, for instance, were gay or bisexual, but this information was quietly glossed over with artificial studio "dates" and marriages.)

A publicist's "handling" of an elite-to-be will probably feel like a cross between this and the public persona cultivated by an XWF wrestling star. This sort of thing may be a lot of fun for the nova. Sometimes, though, it will doubtless go against the grain of the character's personality.

Preparation: Training and Equipment

A fledgling team of elites has a lot of preparation to do before the characters actually see their first battle. A period of study and physical exercise is nearly indispensable. There is also the critical question of weapons: It's hard to be a mercenary without anything to fight with, and the players ought to realize that, powerful as their characters may be, they will be going up in battle against equally powerful novas — some with really big guns.

Elites who are working under a managing agency will probably be supplied with weapons and transport vehicles and receive some training in how to handle them — a major advantage of being part of a corporate “family.” Those who take the independent route should examine the resources they have available and stock up on some elite-class weaponry. A transport vehicle is probably also a good idea — the characters may need it in order to get themselves on-site in the first place, and it may be useful for moving around quickly once they are there, especially if not everyone on the team has flight or other forms of hyper-motion. (Even those who do may prefer to conserve their energy for battle.) Sometimes, of course, a new team of novas simply does not have the resources to purchase a transport vehicle. In that case, they will have to try to rent or borrow one — or become very creative about getting around.

When it comes to major decisions like a vehicle, it might be wise for the characters to make sure they know what kind of terrain their first assignment will be on before they buy. Of course, then they may need to act quickly. For the lowdown on the weapons and machines favored by elites, see Chapter Four.

For both vehicles and weapons, there are plenty of other possibilities for the nova in a hurry, ranging from the super-chic blacktech manufacturers of Hong Kong and Buenos Aires down to the local black-marketeers: the less expensive — and less reliable — con men who lurk in every part of the industrialized world. With a little creativity, the Storyteller can make the quest for machinery a hair-raising adventure in itself.

Some clients take the initiative and furnish elites with temporary weaponry and/or vehicles, particularly if the client is a large corporate of government interest. This machinery can be very useful. However, once again, the characters should remember that they may need to confront experienced elite mercenaries with professional-class weapons. Therefore, it might not be smart for them to rely upon the military savvy of a government which has hired them to do its fighting in the first place.

However, there are legitimate — and lucrative — ways of raising quick funds. If a team of independent elites finds itself strapped for cash when it comes time to buy some of those wonderful toys, it should not be hard for them to secure a business loan. (That is, if they have gone through the correct procedures to incorporate themselves.) Or perhaps it's time to consider corporate partnership with an advertiser — or even an IPO. If the characters do take out a loan, it's merely an expense they will

have to pay off out of the lucrative paychecks from their first successful assignment... or, if anything goes wrong, it will simply be deducted from their estates.

Of course, there is more to preparation than equipment. If the novas have contracted with a managing agency, that firm will almost certainly provide the new elites with training facilities and tutors. After all, there's more to warfare than simply fighting: New elites have to brace for the culture shock, strategic negotiations, guerrilla fighting conditions, ethical dilemmas and psychological traumas that war often creates. A company which has experience in managing novas may be able to help brace the characters for what they'll experience in their first assignment. An independent team, operating without any such source of experience and advice, may find itself at a greater disadvantage when entering war for the first time. But everyone's first experience of war is a surprise... and no matter how thorough their training, each of these novas will soon enough have to experience war for themselves.

Entering Combat: A Whole New World Into the Battle Zone

Now the characters have signed all the paperwork, decided on their elite personas, invested in high-quality weapons and gone through their basic training. They have gone most of the way to reinventing themselves as elites: Passing through a second self-creation, similar to that which the players performed when they first generated the characters, the novas have remade themselves as quantum-powered mercenaries. Congratulations. Now what?

Next, of course, the characters are hired for an actual mission. Here is where the relatively cozy world of the elite-in-training suddenly goes global. Although the characters might, conceivably, be hired to work on some sort of local problem — as agents for a corporate espionage mission or temporary riot police for an insurgency or local uprising — it is vastly more likely that they will be tapped to become part of one of the international conflicts which are constantly being waged around the globe. In short, the characters have suddenly become key soldiers — and, perhaps, weapons — in an international war.

Obviously, the Storyteller should think ahead of time about what sort of situation the characters will be dropped into. Of the military conflicts currently going on in the **Aberrant** world, some of the most high-profile skirmishes are detailed in Chapter Five. Any of these would make tidy spots into which to drop a new team of elites. The perennial hot spot is Africa, which, alas, is as thoroughly war-torn in 2012 as it was half a century before: Innumerable border wars are blazing there, and many African governments are continuing their long history of bringing in outside mercenaries. The conflict in Kashmir is similarly spectacular, with the added threat that either or both sides might be a little too cavalier about the nuclear weapons which they are rumored to be stockpiling. Global buzz is also carrying rumors of something heating up in the Koreas. Even First World

countries like Canada are becoming sites for conflict. The Storyteller should also feel free to devise a completely different military conflict which will require the characters' participation. Perhaps this battle is occurring in a small country, not so visible in the world's eye as Kashmir, but war-ridden nonetheless.

If the elites are working as free agents, they will probably find themselves talking to a client who represents some national government or international organization that is interested in contracting their services. (This client will probably not reveal his real affiliation to the novas until after he has already held some discussions with them; if they strike him as boorish, immature or untrustworthy, they may drive him away before he makes an offer. Alternatively, the characters may find themselves visited by a low-key agent who will then put them in contact with another higher-up. After a while, they'll figure out that they're being screened to see if they are good enough to meet with the real person in charge and to get the full information about their potential mission. Government agents on the lookout for mercenaries or espionage agents don't usually whip out their business cards at the first opportunity.)

If the novas are working for DeVries or another mercenary contracting agency, they may not even get the chance to meet the client hiring them. (On the other hand, presumably, some agents will want to see who they were hiring; the elites' company liaison may even make them put on a "song and dance" for the client, which the novas may or may not resent.) Elites working for a larger company may not have the chance to ask many questions about their new employer until after the contract is signed. The Storyteller may wish to remind them at this point that they are signing on for a war: If they have any questions about the details or ethical justifications for the battle they are to fight, they had better ask them now. Frankly, however, in the heat and excitement of a first assignment — as the fledgling novas sit comfortably in their well-appointed, first-world headquarters — the characters are likely to forget to ask these questions. The Storyteller may wish to bring them back to this moment later on, after they've discovered what their assignment is really like. War always looks different close up.

The deal will be closed, and the contract signed. The team will hustle to make its final preparations — if they have a managing agency, they will be equipped, briefed and prepared by the agency's warfare specialists — and then, with perhaps startling swiftness, they will head off to their first battle.

Their travel may take the form of a media-heavy grand entrance, but it is more likely that, under cover of night, they will be airlifted halfway around the world and dumped into the middle of their new assignment.

Information Fog

As the preceding paragraphs may suggest, the characters are likely to find something a little disturbing happening to them. As they hurl themselves enthusiastically into their military assignment, they may begin to get the feeling that they haven't been told everything that's really

happening. This is one of the consequences of a mercenary assignment: It's likely that the characters *won't* know exactly what's going on at any given time. They will probably have a contact from the government or the organization which has hired them, and this contact will give them background information and will tell them what they should be doing, who they should expect to be fighting and where and when to show up for battle. However, there are several things that the characters ought to bear in mind:

First, all wars are wars of ideology, and everybody has a side. Therefore, the "explanations" which the characters receive about the conflict they're about to engage in will be unavoidably slanted to favor the side telling the story. Second, there may be entire chunks of information about motives, weapons, factions or other things which the characters won't be told because they're not sufficiently trusted — and one of these military secrets may pop up later and surprise the characters. Third, the liaison telling them what they're fighting for may be lying. Motives and morality get blurry in wartime, and even if the characters thought they knew what they were doing when they got into this, they may gradually get the uneasy feeling that they're not fighting for the good guys after all. Moreover, it may turn out that there are important "secrets" which everyone but them seems to know.

Fourth, as the old joke says, "Military intelligence is an oxymoron." Wars are full of secrets and surprises, and even if the characters' employers are acting in good faith, they cannot tell the characters things that they don't know themselves. This is even more likely to be true if the characters' employers are staging an invasion or trying to occupy unfamiliar territory — regardless of the excellence of the reconnaissance, there are things invaders can never know about the native terrain and resistance.

So... is there a militant religious-fanatic faction that has been keeping a low profile in the jungle villages, donning the robes of temple monks when the invading soldiers pass through? And what about the fabled "white oasis" that the natives say appears and disappears like a mirage in the desert, from which so many diseases (and such strange machines) seem to originate? The fact that the enemy the characters will be fighting tomorrow isn't really some upstart called Gore Hound but the dreaded Totentanz himself? The characters' employers couldn't tell them about that kind of thing, because they don't know about it themselves.

Given everything the characters' employers don't know, combined with all the things the employers do know but probably don't want to tell the characters, a series set inside a war campaign will probably yield periodic revelations: The characters will learn something important about the war which they hadn't know before. The characters may even feel, as they fight their way through conflict after conflict, that they're not completely sure where they are going or what they are doing. The truth will keep shifting, altering and rearing up out of the mist and looking a little different — and the characters will constantly be realizing just how much they don't know about what's going on. *This* is what cynics call military intelligence and what mercenary elites and other hired agents of

the early 21st century prefer to call “information fog.”

As was mentioned above, a series like this can be played on any of several levels of “reality.” The characters can also be given information and be involved in strategy to any of various degrees. If, for instance, the players happen to be interested in wargaming and strategy, the Storyteller might decide that their employer comes clean with them and lets them know in full detail what the battle plans are or even decides to take advantage of their nova brains and consult with them about strategy. This would allow the characters to participate in strategic planning. If, on the other hand, the players enjoy roleplaying combat but would be bored by the ins and outs of military strategy, it’s fair for the Storyteller to gloss over the details, simply saying that the elites are kept more or less in the dark about what goes on outside of their immediate area of influence.

The characters may begin to get antsy, realizing that they don’t know exactly *why* they were supposed to kidnap this tribal leader or blow up that rural water-purification plant. Once they begin to question the morality of their actions, the stage may be set for some unexpected revelations from unexpected sources. (See “Ethical Issues,” below.)

The Mercenary Environment

Drowning in the Unfamiliar: Culture Shock

When characters find themselves dumped into the middle of a foreign conflict, they *should* have a sense of culture shock. Not only are they in a part of the world they have probably never seen before, among people with unfamiliar customs and attitudes, but if the characters are first-time soldiers, they must get used to the culture of war as well.

Players and Storyteller alike should remember this: While there are various conflicts in wealthy, first-world nations — especially around the touchy issues of espionage and illicit nuclear weapons — most of the world’s fighting occurs in what, even after a decade of Utopia’s attempts to save the planet, is still called “the Third World.” Despite the pleasant ideal of a “global community,” in 2012 not everyone has a piece of the Utopian pie. Most of the places where armed struggles are occurring have not seen their share of the glory days promised by Utopia and the UN. In the jungles, deserts, swamps, flatlands and stone cities around the world, in Africa, Latin America, Southeast and Central Asia, life for most people is just as it was 50 years ago... and, often, that means it’s little different from the way it was a century ago.

One significant change, however, is the expansion of global media to nearly every corner of the globe. Although many people don’t have much, they now know what it is that they don’t have. As a result, many people of the so-called “Third World” are angry, feeling that they have been disenfranchised. It seems as if the difficulties which plague their

lives — poverty, disease, lack of access to education and technology and war itself — should have been ended by Utopia and the novas, just as these evils have been ended or eased elsewhere. But citizens of the Third World also know that they are on the bottom of the list for that kind of help: Their homes are thought of by the West simply as the infinite “dark corners” of the world, with too little prestige to attract attention and too little clout to force the point. Furthermore, these parts of the world are relatively nova-poor, since novas do not flock there, and those who erupt usually leave for more prosperous and glamorous climes.

If their mission takes them anywhere in one of these countries, elites will probably find themselves the focus of contradictory but fiercely felt emotions. Some local people will associate them with the betrayed promise of Utopia — whether or not the elites actually have anything to do with Utopia — and treat them with a strange mixture of reverence, hostility and hope. The elites will also be subjected to exhortations and requests from unexpected sources, in which villagers or guides might express to them their personal opinions on world nova politics — which the elites should find very educational, once they learn to listen. More distressingly, the natives of regions torn by war or poverty may urge the characters to bring more attention to the plight of nations like theirs — almost certainly overestimating both the characters’ influence in world affairs and their altruism.

Of course, there will also be staunch traditionalists who are glad that “at least here, the old values remain.” They will treat novas with hostility, trying to keep young people away from them and muttering that they’ll be glad to see the novas go. And the characters will also find the inevitable nova groupies: people who are enthralled with their nova beauty and power and the promise they seem to carry of another, more glamorous world. Young people will follow them, teenagers will want to have sex with them....

The details of this will vary by place, of course, and the Storyteller should work up an idea of what the prevailing local attitudes toward novas are. But Storyteller and players should bear in mind that, even in a supposedly hostile territory (like the Shi’ite Islamic countries), those attitudes are unlikely to be monolithic. Human beings and human cultures are complicated, and different people will react in different ways to the characters.

Physical Environment

Military headquarters range dramatically in style and level of comfort, from high-tech urban command centers to poorly fortified base camps in the jungle. While an espionage mission might find the characters HQed in sleek government quarters somewhere in an East Asian megacity, the odds are higher — especially if the characters have contracted out for one of the interminable internecine or border wars — that at some point the characters will find themselves in a ragged base camp in an anonymous jungle or desert, in a village that doesn’t even have a name on most maps.

The Storyteller should describe to the characters their new physical environment, in order to enhance the

mood. Imaginative details should remain within reason: Southeast Asia is not a desert, and the characters won't find rain forest in the Middle East, but the Storyteller should feel free to sculpt an absorbing environment for the players. She should draw inspiration from any material that inspires her imagination. For a mercenary campaign, this might include Vietnam War movies, the romanticized African adventures of the French Foreign Legion, last month's National Geographic or personal real-world travel experience. Detailed images create a sense of sensory immersion: The Storyteller may describe base camps in steaming jungles, tiny villages with street markets and elderly vendors on bicycles and forts pitched in windswept deserts where water is a rare treasure. She should help the characters really feel the texture of the strange new world surrounding them.

The Storyteller should also feel free to make the characters uncomfortable. Even with the flashiest nova powers, most novas are vulnerable to certain irritations: unfamiliar extremes of heat or cold, dry air or clinging jungle moisture, biting flies that whine all night or fine particles of gritty sand that work their way inside weapons and folds of skin. And no one should forget the exciting gastrointestinal diseases that may come with the local water. Although the world's water supplies are generally healthier in 2012 than they were 10 years before

and although novas are resistant to most diseases, it's an embarrassing fact that even novas can't be 100 percent sure of avoiding a case of the trots. (This is why an experienced handler will send out its mercenaries at least a week before they are scheduled for battle, in order to let them adapt to their new surroundings.)

However, even the most sadistic Storyteller should remember to point out the beauty that may also accompany the new environment. Novas quartered in an unfamiliar part of the world will be faced with new experiences: the solitary majesty of a rolling desert in moonlight, the diversity of life forms inhabiting a rainforest or jungle or the unusual jewelry, manners, art forms or body adornments of the local people. The characters are in a genuinely new situation, and they should learn from it and grow as people — after all, there's more to all this than just the battle scenes. In fact, under certain kinds of Storytellers, the battle scenes may turn out not to be the real “point” of a mercenary campaign at all — and *that* may turn out to be a real surprise to players and characters alike.

Interaction with the Military

Depending on the degree of “information fog” enveloping them, the characters may or may not have a clear sense of the nature of their mission or of the political context of the conflict they've been plunged into. Similarly,



the characters may experience a greater or lesser sense of isolation and secrecy. If they are stationed in a city center, they will feel more in touch with the flow of humanity around them — but perhaps also more alienated — than if they are stationed in a small town or village. If they are in an isolated camp in a jungle or desert, of course, the situation may feel even more surreal; the characters will have plenty of time to think and talk in between battles — and they will have little else to do.

Media attention is another factor to think about. If their movements really are covert, then the characters may be completely invisible to the world's media radar. On the other hand, if the characters or their mission is high-profile, representatives of major news outlets will be buzzing like flies around the novas' HQ — and the planned locations of the battles. The characters may also have colleagues — or competition — in their mission. They may have been hired as an independent strike force. On the other hand, they may be quartered with other elites hired by the same government, beside whom they may be expected to fight. These scenarios provide an interesting array of possibilities: If there are other mercenaries present, will the characters get along with them? Can they learn from their more experienced allies? Or will the other elites take a dislike to the upstarts?

If the characters have signed on to be part of a high-profile, full-scale battle force, they may be surrounded by baseline soldiers. Even elites working alongside conventional armies are not usually housed with the enlisted men. When that has been tried, there have been hostile incidents — in a number of different nations' armies — which suggest that mistrust and bigotry create obstacles to integrating novas into conventional armed forces. Observers of the US Army's integration efforts, for example, have documented a surprising amount of hostility, originating both from the baseline forces and from the novas who are their super-soldiers and secret weapons.

Interaction with the Locals

No matter how isolated they are, the characters will probably have some kind of interaction with the people around them. If they have been hired as part of the defending side of a war of invasion, the characters be fighting alongside people who are trying to defend their land and homes; if the characters are fighting for invaders, they will still come into contact with locals. After all, nearly any invading or occupying force has to strike bargains with some of the native inhabitants.

Except in the most secretive of campaigns, the elites are unlikely to be kept in complete isolation. If they are in a fort or a military base camp, they will be local interpreters, couriers, advisers and, probably, janitors and menial workers around. It's also likely that, near the fort, there will be one of the population centers that seem to spring up around military bases; this may be a transient village of local folks who sell services, recreation and food to the soldiers. (Such a village will probably include

a whorehouse as well.)

If, as is more likely, the characters are quartered in or near a village, there will be a constant flow of native people around them. Some of these people are bound to want to talk to the novas. In fact, even if the characters are in an isolated camp in the middle of a jungle, the enemy forces will manage to send a representative or two under cover of night to try to talk to the enemy elites. In conflicts like this one, everyone has an interest in getting the ear of the elites.

When native people try to talk to the characters, the novas can choose to send them away, of course, or to attack them, if they are enemy agents. But they might do well to listen to them, instead.

Local contacts may have a variety of motives for wanting to talk with the elites. Some will be there for the same reasons as first-world groupies. Depending upon local custom, belief and degree of media connection to the First World, some locals may be part of a cult of nova celebrity worship, wanting to touch the characters or obtain souvenirs. Women or men may want to sleep with the characters, either asking money or offering their bodies for free. The novas, of course, must choose whether or not to take advantage of these offers.

There may also be interactions that raise more serious moral and ethical issues. In some parts of the world, people may bring sick children or relatives to the "god-like" novas, asking for healing — a practice particularly common in war-torn regions. Locals may flock to the novas and beg them for protection. Others may ask to come home with them when they leave. Faced with such dilemmas, the characters must decide how to deal with people who place all their hope in them.

Combat and its Consequences

Zap! Bang! Boom!: Nova Conflicts

Eventually, every mercenary mission culminates in battle. When the characters finally get down to it, this fighting can take any of several forms. Perhaps the characters are being kept in reserve, to be deployed as a "secret weapon" in a spectacular final battle. Or perhaps they have been assigned to destroy specific strategic points. The most common scenario, however, is that they will be put into conflict against specific enemy novas, in order to determine strategic flashpoints in a disputed zone.

When the time to fight arrives, the characters (and players) may welcome it eagerly. After slogging through jungles, trekking across deserts and getting sick in little huts, battle may seem like the "real point" of their entire elite experience. A Storyteller who is interested in telling a complex tale may need to remind the battle-happy players that their characters' experiences as

mercenaries in this campaign has been about more than battles. In fact, in some war series, the nova battles will be one of the least important factors in deciding the war — or in playing the game. This is an important point and should be considered and revisited by Storyteller and players alike.

So, what are nova battles like? After days or weeks of preparation and waiting, the characters finally watch the opposing battalion of novas rise over the crest of a hill — or perhaps it's their own team which is caught in an ambush. What happens then? What occurs in the famed, dreaded, desperately fascinating elite combat, which the world watches breathlessly on OpNet and to which generals hang on with bated breath? What goes on in those battles between the few powerful soldiers who can decide the fate of nations — and the course of the lives of millions?

Well, the battles are more or less the way you might imagine them to be... *any way* you might imagine them to be. Most people have a general idea of what nova battles are like: a mixture of many kinds of powerful, dazzling attacks — airborne combat, searing quantum bolts spraying everywhere, daring mid-air maneuvers, elemental forces battling over a swathe of jungle and winds, weapons and amazing vehicles or creatures doing battle above the upturned faces of the ordinary people watching below. If this is the culmination of a long campaign or a heavily publicized war, there may also be hordes of media types buzzing around — or sending their dangerous self-propelled cameras into the combatants' airspace.

Nova battles should be as spectacular as the players' imaginations will allow. The Storyteller is responsible for a certain amount of choreography: She should know ahead of time which elites the characters will be fighting and how the various novas' attacks will interact with each other. The characters may also have had a chance to prepare themselves to face these specific foes. On the other hand, they may have no information — or wrong information — about their opponents; "information fog" is often densest around the most critical points of knowledge.

For their part, the enemy forces may have better intelligence than the players' characters and, thus, more time to prepare attacks and defenses against the characters' specific abilities. In such instances, the practical value of information suddenly become painfully clear. Characters who have researched the tactics of the novas they are fighting should certainly find that they have an edge over those who are going in blind; in the meantime, they may find that they are facing fighters who are very well prepared against *them*.

Most agencies also have their own policies about various kinds of assignments they will and will not accept. Certain high-profile novas might be unlikely foes for new elites who are — or who believe they are — fighting on the side of the angels; some elites are unlikely to be found defending despots, for example, or

assisting invading forces.

The Storyteller should use her creativity. It should not be hard for her to come up with rather terrifying new elites. The characters may have a hard time believing that it's just by coincidence that these elites seem to be so eerily well-equipped against them.

Creative use of their nova powers, the ability to strategize, able teamwork, superior firepower or enough simple good luck will enable the characters to hold their own against the enemy. If they are efficient and lucky, they may even be able to bring down an enemy or two. Of course, an official unmasking would be quite a coup — and perhaps a little too much for a team of first-time elites to expect — but, then again, anything is possible. The fight may be quick and brutal, grind on for hours or even end too quickly: The enemy could always flee, leaving the characters unfulfilled and yearning to chase down their opponents and finish the job.

Depending upon the type of mission which the team has been assigned, they may need to attain a goal beyond simply bringing down their opponents. For instance, after clearing away the defenders, perhaps they need to destroy a munitions plant — and that means they must figure out how to do that without incinerating everything within three square miles. Or perhaps they need to rescue some hostages from a tense situation. A task like that will require more finesse than simply charging the fortress; after all, no one wants the opponent to get trigger-happy around the hostages.

Or perhaps the characters' mission is a duel of honor — a sort of war fought by proxy, in which the winning side keeps the land and takes the victory, in order to spare fighting with ground forces. In these situations, even if the characters are not wholly successful, it is still possible to win a partial victory — for instance, the characters successfully bring down the novas guarding the enemy's subterranean base but are not able to retrieve the enemy's weapons prototype before an operative inside the base blows up the bunker and its contents. This sort of thing is less exhilarating than a complete, sweeping victory, but the Storyteller may feel that it makes for a more textured and interesting story. In fact, a partial victory may be more interesting than a complete victory. After all, you can't win them all. And even a partial victory like this one would certainly enhance the characters' status as effective warriors — though perhaps not as top espionage agents.

The Gray Areas: Ethical Conflicts

"It was necessary to destroy the village in order to save it."

— American soldier in 1968 report on the razing of the Vietnamese village Ben Tre

There will always be missions which do not run smoothly. Then there are missions which blur into shades of gray, harboring moral ambiguities which cannot be neatly resolved. New elites may encounter these issues during their first tour of duty and will have to be prepared to deal with them.

ABERRANT

Many of the assignments which elite teams carry out in the line of duty, particularly during extended conflicts, do not pit them against other elite fighting teams. Instead, the missions require the capture or destruction of enemy sites, weapons, vehicles, information — or even key enemy figures. This kind of assignment often puts an elite into a morally hazy position: They may be asked to attack baselines, including powerless soldiers or even civilians who happen to be on the enemy side.

Idealistic first-time elites, coming face to face with this reality for the first time, often receive a shock as they realize that what they are being asked to do may not fall under their definition of “honor.” Savvy elites or those belonging to particularly scrupulous managers often have clauses in their contracts which specify that they can refuse to attack civilians (or baselines in general), but those who haven’t bothered to check their contracts closely may find themselves in a bind. Characters have the choice, then, of either violating contract — and presumably ending their elite careers just as they’ve begun — or deciding that all is fair in war and figuring out how to adjust their senses of morality to manage the tasks they have been assigned.

Even novas who aren’t directly asked to attack baseline forces may find themselves in a similar dilemma. If characters are asked to make a sneak attack by night, strafing the village where the guerrilla rebels are known

to be hiding, they will realize that it will be impossible to avoid killing and injuring civilians. (And does it make them feel any better to know that the civilians must be in cahoots with the rebels?) There are also less immediate but equally ambiguous situations — such as those “Cloudburst” Shechter described in her interview. If characters are assigned to destroy the water-purification plant that filters deadly bacteria from jungle sources or the only well in 60 square miles of desert, they may deal a crippling blow to the rebel cells in the region — but there are also a lot of local children who are going to get sick or die of thirst in the following weeks, after the novas have returned to their posh urban homes with their five-million dollar paychecks.

Do the characters really have the stomach for this? Will they be able to grit their teeth, tell the nagging voice of conscience to shut up and carry through with their assignment? And after they’ve returned to their exciting, glamorous nova lives, will they be able to keep those voices quiet? Or will they keep hearing the voices of the people who pleaded with you not to destroy them, or seeing — like Cloudburst — the blind, white eyes of babies?

Not everybody can handle these situations. In fact, this is the explanation for one peculiar fact about elites which is seldom broadcast to the world: The attrition rate of elites is amazingly high. Of recently erupted novas who



sign on to work for mercenary agencies, between 22 and 31 percent quit after their first mission. Another 44 percent or so quit before they've completed five assignments.

Far more than the mortality rate of elites — which is actually very low, given the extremely hazardous nature of their work — this statistic explains why there are relatively few long-term, successful career combat elites. Among those who do last, a fair number had military experience in their “past lives” (i.e., before they erupted). But even among career soldiers, a surprisingly high number lay down the metaphorical sword after only a taste or two of the elite biz.

Many observers speculate that the reason for this is fundamentally simple. As a nova, a mercenary has power over life and death — in a much more literal sense than the way in which this is true of an ordinary soldier. The experience is, perhaps, like being the only person in the room with a gun, but magnified in potency a million times.

“War is Hell”: Psychological Repercussions and Post-War Trauma

The Craiglockhart Centre for the Treatment of War Disorders sits quietly on the coast of New Guinea. It was established quietly by the UK in 2005, after government officials, reviewing the diagnoses of some military elites, realized that they had a new type of psychiatric patient on their hands.

War trauma and its psychiatric repercussions are well known to military psychiatrists. However, super-powerful nova patients raise new sets of issues, which only a state-of-the-art facility can address. Craiglockhart is now run as a joint venture, with input and support from several other national governments and from Project Utopia itself. As a facility, it is unique in the world, and

visitors receive the impression of a high-class, humane mental hospital crossed with a maximum-security prison.

Craiglockhart is named after the British Army hospital in Scotland where shell-shocked victims of World War One, including the soldier-poets Siegfried Sassoon and Wilfred Owen, were sent for treatment. It aims to reproduce that asylum's results, offering the highest class of care, kindness and rehabilitation to its patients. Craiglockhart boasts a top-flight, tightly knit staff of military and civilian medics, psychiatrists and psychologists — including a few novas — from several nations.

The existence of Craiglockhart is not precisely classified as a secret; that would look too suspicious if the media ever decided that a cover-up was going on. However, its agents exert much effort to make sure Craiglockhart keeps a very low profile in the world press.

There is not much demand for paraphysicians, since their physiology makes novas them far less vulnerable than baselines to injury and disease. Psychiatric imbalances, though, are a different matter. Novas who go to work for their country's military show a rate of war trauma *higher* than that of baselines, and some psychiatrists at Craiglockhart have voiced the idea that nova war trauma is not as simple as trauma in baselines. In novas, the trauma usually results from the accidental (or, in many cases, deliberate) deaths of dozens or more people, whose destruction the nova has caused with his powers. Thus, it is elites' very power — the power for which the world offers them rewards and accolades for using — which ultimately drives them over the edge. Some psychiatrists even offer the more disturbing idea that there is something in nova physiology which *predisposes* them to go over the edge, but that viewpoint remains thoroughly in the minority and is discounted by most.

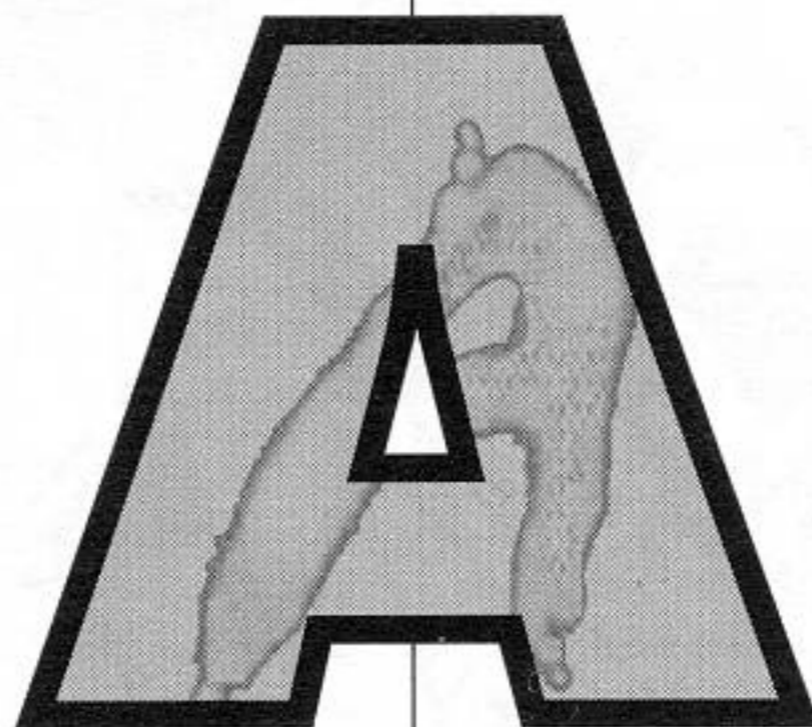

CHAPTER THREE: ELITE LIFE



Excerpt from Carmel “Calamity” Callahan’s weekly therapy session, Craiglockhart, June 11, 2007.

Case history: Callahan, a nova with the abilities of flight, force shielding and the power to project enormous heat away from his body and into narrowly targeted zones, was employed by the US government during the conflict in Tanzania. He was admitted to Craiglockhart for testing and rehabilitation in late 2007 after his involvement with the unfortunate “Field of Glass” incident in August of that year. In November, he was admitted to the hospital as a full-time patient for an indefinite period of time, or until rehabilitation, whichever “happens first.”

— Dr. W.H. Rausch-Rivers

Carmel Callahan: So during the conflict, I had been doing mercenary work in Tanzania, for the government. This was late in '07. I guess, I was still pretty new at this, but I was getting some experience under my belt, and I was improving every day. And, you know, I'd been in training with the Marines when I erupted; I was thinking of being a career soldier anyway, and the eruption seemed to make me, you know, more valuable. I felt as if I had become a much better soldier. Working as an elite, I could actually see the effectiveness of the work I was assigned, and I knew I was actually helping our government win the war. I had been assigned a few missions by various agencies, and I had taken care of them really well: munitions plants vaporized without triggering massive explosions and ecological damage, that sort of thing. I was really proud of that work. Hell, I still would be — except....

Then, of course, the *real* battles involved taking on other novas. And I was good at that, too. I mean, you remember how the press was about me at that time. I was terrific! I took down Heraclio “Hercules” de la Paz and Salaam Farhat, who was calling himself the Windstorm then. I was baaaaad.

Dr. Wilhelmina Helene Rausch-Rivers [Craiglockhart psychotherapist]: Tell me what happened in August, Carmel.

Callahan: Um, okay. We were making steady progress toward the next objective, when I was told one night that the next day I'd have to take out this fort-cum-weapons plant. It was key, they said; it was really important to the opposition's war effort. And I'd have to go through a nova to do it. They weren't sure who the enemy had hired,

but they thought it might be Totentanz. He was still at the beginning of his career then, but he was already terrifying; he was a name to conjure with. Frankly, somewhere behind my big show of confidence, I was afraid he'd kill me.

So I spent the whole night before kind of — you know — worrying and praying and pumping myself up for the next day. I got down on my knees, I talked to God, and I remember asking Mary for her special help. I mean, I ain't usually religious, but this mission really had me rattled pretty bad. Mary has helped me a lot since I was a kid. That makes sense to you, doesn't it?

Dr. Rausch-Rivers: Yes, it does.

Callahan: Good, Because I wouldn't want to think that was weird — you know, an elite praying. Some of us do believe in God.

Dr. Rausch-Rivers: I know, Carmel, and we have touched on this before. But I think we should put off that discussion till a later time. Right now, I feel as if you're trying to stall about something.

Callahan: Uh... stall? Uh...

Dr. Rausch-Rivers: Carmel, what happened the following morning?

Callahan: (voice cracking) Okay. Uh, well, so, I spent the whole night, you know, kind of worrying and praying and pumping myself up for the next day. And then, the next day, everything happened as fast as usual: We were up, we were moving, we were screaming toward the fortification. And there it was, you know? There was the target. I started attacking it....

[pause] [a sound of heavy breathing] Uh, this is where it gets hard....

...I was all primed to attack Totentanz, you see, after the night before. I was ready to — you know — to give him everything I had. I just wanted to blow him to rubble. I was so high on adrenaline, I could hardly see; everything was moving so quickly...

Dr. Rausch-Rivers: Had you been provided with soma by the US government?

Callahan: What? Uh.... No, of course not.... I mean... no. Like I said the last time, no.

Dr. Rausch-Rivers: That's all right. Go on. What happened?

Callahan: Well, there we were at our objective, and it was just a sort of rickety fort, wood and metal, heaped

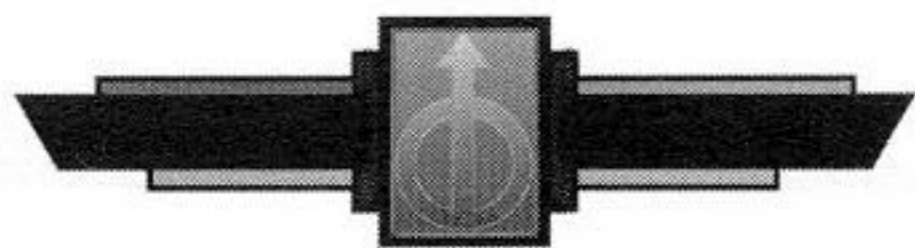

with piles of sandbags around all the doors — probably 'cause it would have blown away otherwise. And suddenly, the doors of the fort opened, and all these people came pouring out — just flooding out of those doors. They were all these, well, these enemy soldiers. There were dozens or hundreds of them. Some of them had guns, and they opened fire at me. It looked to me like there were just thousands of them, and I was so pumped, so primed to *kill* Totentanz — and I swear to God, I thought, it looked to me like I saw something rising out from above the fort.... [breaks off, sobbing]

Dr. Rausch-Rivers: (gently) Go on, Carmel.

Callahan: (voice shaking) So I just kind of... let it go, you know? I ripped out with all my power at the fort, that... flood of faces, that sea of people... and... oh, my God. They were just soldiers. You know? They were just kids! Oh, God, please forgive me....

Dr. Rausch-Rivers: Carmel, it's all right.

Callahan: People say to me, "You didn't do anything wrong, they had guns." They had guns, but what could guns have done against my force shield anyway? Those poor guys could never have hurt me.

Of course, Totentanz wasn't even there. The generals told me later that there had been an intelligence error, that they had really thought there was going to be a nova there. But there was no nova, just dozens and dozens of scared, stupid kids working for the other side, terrified out of their wits to see this fiery nova attacking them.

They thought I was going to *kill* them, you see. And I... I did.... I didn't mean to, but I did. I unleashed my full quantum power, and it was... well, you know how powerful I am... how powerful I was. It's how I got my nickname.... I gave the whole area the Calamity Blast — that's the super heat, you know, my trademark. I can't believe how proud of that I used to be. Dumb-ass macho dumbfuck.

Dr. Rausch-Rivers: Exactly what happened, Carmel?

Callahan: I gave it the firepower and melted the munitions plant, like I had planned — the stone melted to slag and all the sandbags surrounding burst and fused into glass, you know. That's what sand does when it gets too hot — but, uh, but all over the glass — you know, I didn't shoot right *at* them, but they were too close by — and it melted all those — *kids* standing in front of

it.... [long pause] (voice begins to shake) Those terrified kids with their terrified frozen eyes. That's all I can see now. I mean I see it when I turn around corners, and I see it when I try to go to sleep, and I see it when I try to use my powers! That horrible, shining mass of... of... of glass on the ground and the slag bodies and the *bones*. Oh, God, and arms just sort of sticking out of it all and the pink and black stuff oozing all over the glass and the eyes not connected to anything, burst eyes, unburst eyes fused into the glass, watching me....

Dr. Rausch-Rivers: Carmel—

Callahan: ... and those horrible, horrible charred hands holding onto slagged guns, clutching on hard just as tight as you'd hold a baby.... I killed 143 dumb, unwilling kids! I will never use my powers again. Oh, God. I will never be forgiven....

Dr. Rausch-Rivers: Please calm down, Carmel. Joey, could you send for Marie and Selima?

Callahan: Oh, my God. I swear the Lord hates us all or is testing us and trying to destroy us. I don't understand how anybody could be like me, and kill people like me, and not go crazy. I guess I just went crazy early. Maybe some people can do this kind of job, but, man, I'm terrified of them. You know what? I think Totentanz is more than an icon. I think anyone who kills that easily really is Death. I bet he doesn't get nightmares. Oh, God, I'm not human any more. You all need to be careful. Be careful of people like me! Will you tell them I said that? Will you, Dr. Rausch-Rivers? Tell everyone — please?

Dr. Rausch-Rivers: Of course, Carmel. It'll be okay. Why don't you let Marie give you your tranquilizer now?

Callahan: Good idea. No, wait, these aren't strong enough. Could I — do you think I could have some of the green pills? I keep— No! Please pull down the blinds. The sun's starting to go down, and I don't want to look at the window.... Please, come on, I can see my own face behind you.

Dr. Rausch-Rivers: Marie, could you get the blinds? Hurry—

Callahan: And you know how I get about reflections. Oh, my God! Please, please, get me out of here, help me, my eyes are watching me in the glass!

Recording breaks off



THE FRUITS OF COMBAT

Of course, a series doesn't have to end on such a down note. More likely, the characters have succeeded in their missions, retained their sanity and returned to report to their client. They have won the war and saved the day. They are media darlings — and now they all get *paid*. (Or, perhaps, they lost, but get paid anyway. Most elite contracts have a stipulation for this, although the Storyteller should freely award egregious bonuses from the grateful employer to celebrate a full-fledged victory. Only a very shady employer makes the payout contingent upon victory: After all, the novas are putting their lives on the line for their client.)

If the characters come from wealthy backgrounds, it's possible that the payoff from an elite contract is nothing new. However, most people on the planet — nova or baseline — have never had quite that much money in their possession before. What will the characters do with it?

There are as many ways to spend money as there are things to do in the world. However, the most commonly selected paths fall into one of several categories. (Of course, millions of dollars is enough to split the take among a number of these goals.):

Investment: This is the conservative path to take and may not seem the obvious choice for a hot young nova, but it makes financial sense. Investing some of the take would give any of the elites an income which, if they wanted to, they could live off of modestly for the rest of their lives. Many elites, after blowing the entire paycheck from their first contract assignment, suddenly get prudent and invest a chunk of their second paychecks; presumably, they have realized that they may not want to be mercenaries forever (and that their chances of survival decline precipitously with each mission).

A number of financial firms around the world specialize in managing the money of novas, and the top ones employ Mega-Intelligent and Mega-Perceptive nova stockbrokers to manage vast sums — and yield almost incredible gains. It is also possible for a character to combine investment with altruism by investing in one of Project Utopia's efforts or by helping to build up a fledgling organization the character believes in. Investment above a certain amount will, after a set period of time, ratchet up your Resources by a number of points determined by the Storyteller. That extra credit and cash flow may come in handy in series to come.

Self-improvement: Money gives a character the time and leisure to think, study and build up his powers. With some study and application, characters can improve their Traits, Attributes, Abilities or even quantum powers. (See "Character Development," *Aberrant* pp. 123-126.)

A character might decide to spend some time alone doing research in an area of interest or go visit a Project Utopia or DeVries training facility to seek out a mentor and spend some time learning under her. Or the character might seek out trusted novas who

share his kind of powers, for cross-training, idea-sharing and the elite version of networking. On the other hand, for a change of pace he might go somewhere completely different for training. A nova with a martial arts background might depart for the dojos of California, Thailand, Japan, Brazil or Tibet in order to improve his abilities; a cyberkinetic might disappear into the wired world's subculture for a few weeks, to catch up on what the world of baseline hacker culture has been up to while she was gone. After all, despite the illusions held by a few, novas aren't the only people in the world who continue to break new ground.

It's also possible for a nova to embark on a lucrative second or even third career (though this might or might not fall under the category of "self-improvement," it could certainly improve his net worth). For instance, a new elite — freshly back from a successful and high-profile tour of duty — could parlay his recent successes into an endorsement contract or two for advertisers or corporate sponsors. Most elites who plan to do this kind of thing prefer to use either their agency's PR department or to hire an agent. Still, some novas — for instance, those with expertise in areas such as Biz — might feel confident that they can maximize their earnings on their own.

Hedonism: This one is obvious, isn't it? The world is full of sexy, exciting, more or less illegal adventures for those who have the money to spend on it — and that goes a millionfold for novas. A character unwinding from a stressful mission might head for one of a dozen pleasure arenas: Hong Kong, Amsterdam, Rio, A-A, Bangkok, New York or Ibiza itself. Why not spend a few weeks — or months — being one of the beautiful people in the Amp Room? A character might decide to try living the life and "getting it out of her system." She will be free to get tanked, get laid, dance her heart out, buy herself several dozen sexy eufiber suits, build a brand-new "diva" image, put herself in the public eye and know that the little people are swarming around outside the Amp Room just because they love novas so much.

The characters can also learn what narcotic and sexual highs are available to novas, if they have the time and cash to pursue them. After all, they can always consider it research. Hedonism is a terrific way for characters to experience the high life which baselines believe all novas live all the time and to let the cash from their last contracts burn a hole in their beautifully tailored pockets. Hey, if you might die tomorrow, why not live for today?

(Players and Storytellers take note: Hedonistic sprees, devoid of meaning as they may seem, offer plenty of opportunities for novas to make contacts which will prove useful in the future — or to get themselves into trouble. After all, *everyone's* more vulnerable when they let their guard down....)

A lower octane version of a hedonistic binge interlude might be called the "escapism" option: The character gets



away to a beautiful place and forgets the cares of the world but without the fast living and the intense sensations of the orgiastic version. A low-profile world cruise, an escape to a quiet island in the Mediterranean or the Pacific, a vacation to an unexpected place (the Scottish Highlands? Turkmenistan? Alaska?)... any of these options can provide a way for characters to unwind, relax and perhaps even live undercover for a while. This can also be cheaper — or, depending on where the character goes, just as expensive — as blowing an entire salary on Amp Wells.

Altruism: An increasing number of novas are turning their minds, and their resources, to charitable causes. Some are involved in projects that are altruistic on a global scale: environmental preservation and rehabilitation, medical research into treatment for specific diseases or injuries. But others have a more personal focus. Some novas come from families and neighborhoods from which they never imagined they could escape, and they spend much of their money not only helping their own families, but giving back to the neighborhoods they grew up in. (For example, in the United States, the startlingly successful “Detroit Initiatives” were begun in 2006 to research the psychology of poor minority children who are at higher risk for dropping out of school. The project, which has shown remarkable results in channeling urban youth into higher education, was largely funded by Detroit native and “municipal guardian” Kikjak. He channels much of his salary into this program — albeit at the urging of his handlers.

Other novas lend their clout to assisting their nations as a whole; many novas come from “Third World” countries, which have not participated as fully in the dream of Project Utopia as their First World neighbors have. International projects to study and correct this imbalance, such as Monisola Holomisa’s third-world nova think tank draw increasing support from third-world novas and from their interested colleagues. Some elites, on the third hand, feel compelled by conscience — or driven by the connections they feel they made during their tour of duty — to sink at least some of their earnings back into reconstruction, humanitarian aid and peace initiatives in the very areas they have recently been fighting in.

Pump it back into the team’s business, and buy some kick-ass toys: This is definitely the preferred choice for most new elites — particularly if the mission was successful and the team plans to stay together. With the kind of money the novas have now, they can upgrade their headquarters, if they want to: The team could move to the most expensive city in the world, design its own office building, even open a branch office. They can also buy some of the highest-class weaponry and toys available anywhere in the world. The shopping spree can be a lot of fun — although the characters should remember that, while they now have loads of cash, it isn’t infinite. Even several million dollars will only buy so many office buildings and nanotech weapons. All the same, they now have the resources to invest in the toys and gizmos that exist only in the fantasies of most people. But the characters are full-fledged elite mercenaries now, and they can afford them. Maybe it’s time to begin work on that secret orbital space station after all....

N
HOME

N!ertainment

N!terview

N! the news

N!sight

N!tre nous

N!ternet

N!tv

fun N! games

help!

awards

legal stuff

search

find!

**contact
us**

N **terview**

From *Full Nova Extra*,
on N!

It's all about ratings. An elite learns early to pay attention to N!'s ratings — not the programming ratings or the music ratings or even the weapons ratings that N! provides to its audience for reasons that most OpHeads find unfathomable. Elites watch their own ratings. Three factors determine a nova's chart position: sheer pop icon appeal, how many missions he's successfully completed and how many nova enemies he's killed (unmasking doesn't count in ratings). Totentanz is number one and has been for years; his closest competitor is 12 missions and an unbelievable 23 nova kills behind. Nobody expects that to change.

It's not even like it's a choice. It's obligatory; when you're an elite, you have to watch the ratings. You watch to see just how dangerous you really are, to see how your super-secret ninja tricks stack up against the super-secret ninja tricks of those elites you might meet some day on assignment in Tanzania or Kashmir or Quebec. You watch the ratings to see who might be in your league and to find out who definitely isn't. You watch the ratings to see — and nobody admits this in polite company, though everybody thinks it — whom you might kill to improve your own rating, so you can look for them on the battlefield — or in the Amp Room, so you'll know not to get too friendly with them, to get close, in case you have to kill them later. And the big reason you watch the ratings, the one not talked about in *any* company, polite or otherwise, is to see who can kill you, so you can keep an eye out for them on assignment — or in the Amp Room, where you buy them a drink in hopes that they might not kill you if they ever find you in their way on the battlefield. It's an insider joke that Amp Wells have saved more nova lives in combat than all the Utopia-trained paraphysicians in the world.

Since becoming an elite, I watch the ratings very, very closely, and that's how I knew that the big guy who was coming at me in the blue and gray mask with the snarling dog emblem on his chest was Gore Hound, one of the Janissaries, currently occupying the 87 slot on the charts after 14 completed combat missions and four confirmed nova kills. There was one thing standing between him and another completed mission and another nova kill — he didn't strike me as the unmasking type — and that was me. And I was on the charts at the 107 position.

The one thing I had going for me was good tech. DeVries sets its agents up with equipment so cutting edge it looks like magic. That's Rachel's doing. We love Rachel. I certainly did when I saw Gore Hound closing on me with his gorilla muscles and mountain-shattering fists. I'm not an ass-kicker. I'm a stealth guy. One punch from him and I'd be fine red mist settling over the dust at his feet.

So I fired the smartweb at him. It hit dead center; he rolled his eyes like he couldn't believe anyone would try catching a behemoth like him in a net. Then he tried to get out. He stopped rolling his eyes as the net constricted

N

HOME

N!ertainment

N!nterview

N! the news

N!sight

N!tre nous

N!ternet

N!tv

fun N! games

help!

awards

legal stuff

search

find!

N contact us

around him, giving way when he punched but tightening up when his arm pulled back. Then I loosed the mosquitoes. They were full of liquid mox, and each time they stung him, they injected a little into him, and while he smashed a lot of them, I'd brought 2,000. By the time he'd smashed his first 100, he already had enough mox in him to neutralize half of Team Tomorrow. Then I popped a little TK to point the BFG at him and gave him a clip of spent-uranium badness on full auto. That did the trick.

Gore Hound was out cold and the creeping red stain on his nice eufiber outfit suggested that he was bleeding pretty badly. I peeled back his mask. Nice looking guy, mid-20s, probably did better in the dating game than I did, even after my eruption. His breathing was shallow and uneven. I took the carbon fiber garrote, commonly called a murder string, from its case on my utility belt and held it in my left hand. I powered up my right hand with healing juice (always seemed to me that every elite should have the ability to heal as well as kill). It was decision-making time.

Taking out Gore Hound would up my pay-rate by nearly a half-million dollars per assignment. My ratings would go up; killing him would put me in the big C, the top 100. I'd be that much closer to an action figure. I'd get free drinks in the Amp Room. And all I'd have to do is kill this guy. End his life. Make his memories stop. Murder his parents' son.

I put away the garrote. Instead, I put my hand on his bloody chest and felt his failing heartbeat. My hand glowed. His wounds healed. I may regret that some day. Then again, maybe I won't. Ratings only count for so much.



DEVICES

Most elite agencies don't equip their agents, assuming that their agents' nova powers are more than up to the task of dealing with life in the field. DeVries does not subscribe to that view, noting that just because a nova has powers does not mean she'll have the right power for every circumstance. For that reason, DeVries spends an enormous amount of money on research and development to keep its weapons and other equipment at the forefront of technology. Dr. Rachel Alinsky herself is responsible for the vast majority of the more unusual designs, particularly the nanotech insects that have been her fascination for the last several months.

The more common items, (e.g., the ultra-machine gun, the rail gun and laser electroshock pistol) are easily available from any large arms dealer. The exotic items, however, are available only through DeVries, and characters need a minimum of two dots in the Backing Background (with DeVries, obviously) to get them. This is not to suggest that DeVries gives its elites the weapons they need (unless the character has five dots of DeVries Backing); on the contrary, DeVries sells weaponry and equipment to those of its employees who want to be well outfitted in the field. To Anna DeVries' way of thinking, this approach gives the mercenaries something to spend their money on besides Amp Wells, whores and fancy cars. It also makes her a tidy profit. DeVries is nothing if not pragmatic.

Carbon-fiber Garrote

Minimum DeVries Backing: ••

Few methods of assassination are as quick and silent as instantaneous decapitation. The difficulty of the act lies in achieving the "instantaneous" part. However, this implement does the job quite effectively. When retracted, the garrote looks like a polished chrome figure eight, about two inches long. To deploy it, the elite slips one of the rings over the ring finger of each hand. When the thumb-activated safety release is depressed, the rings will separate and appear unconnected. The rings are pulled apart horizontally while maintaining thumb pressure on the release, and they can be separated as far as one meter apart. The invisible carbon-fiber thread that connects them determines this distance. The thread is actually one hugely complex molecule composed of many billions of carbon atoms. As long as the thumb release is depressed, the thread reels in and out, main-

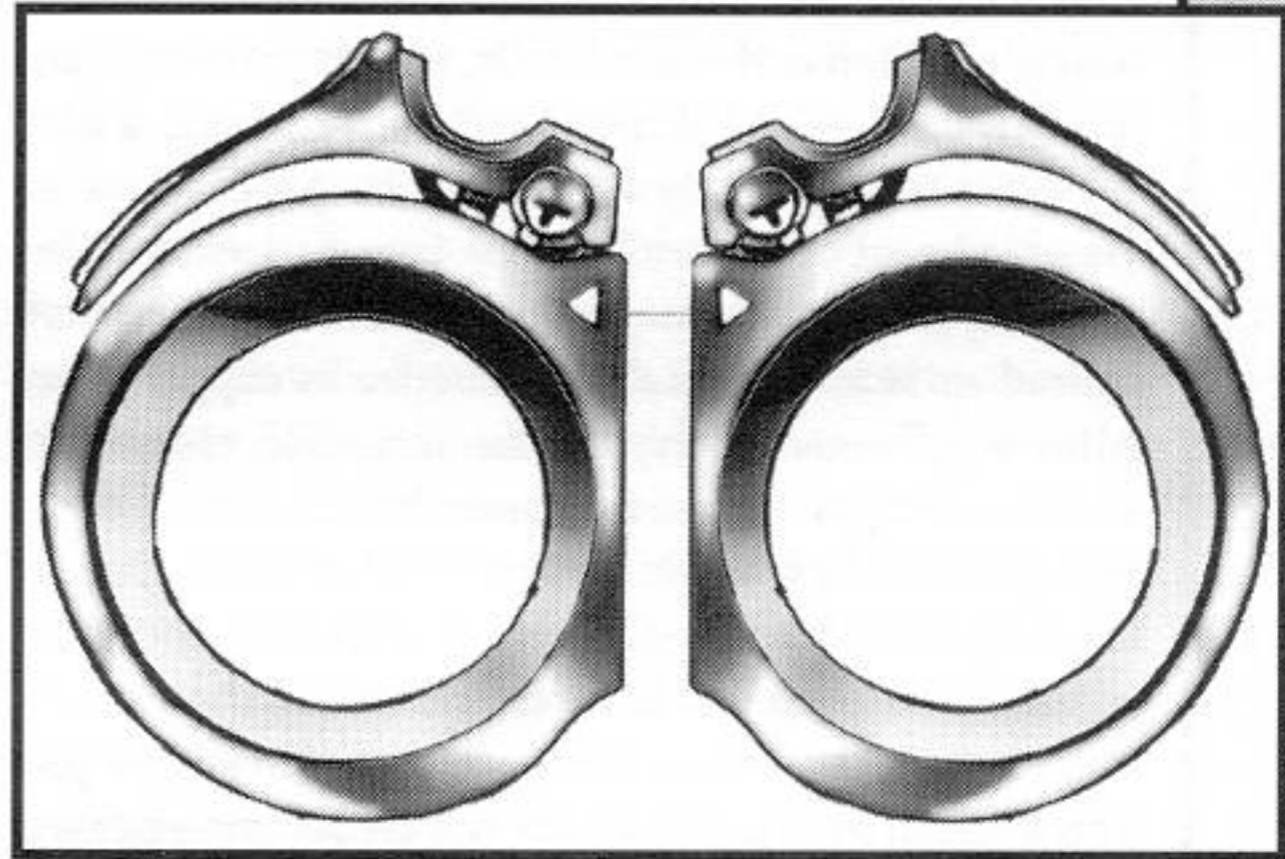

taining a mathematically straight line between the rings. If one relaxes pressure on the release, the thread stays at the current length and is free to bend and loop. To stow the garrote, one depresses the thumb release long enough to bring the grips back into contact. The thread, though microscopically thin, is strong enough as to be unbreakable except by heavy machinery or Mega-Strength, although it can be destroyed by intense heat. Pulled taut, the thread will cut ordinary flesh and bone more efficiently than the sharpest scalpel. With additional effort it can cut wood, plastic and softer metals. It always inflicts lethal damage.

Whipsword

Minimum DeVries Backing: •••

The whipsword is simultaneously a throwback to combat in the age of chivalry and a lethal embodiment of 21st century ultratechnology. Its design is related to the carbon-fiber garrote and uses many of the same technologies. Like the garrote, the whipsword uses a single-molecule carbon filament as its cutting edge. When deactivated, the filament is retracted into the weapon's two-handed hilt. A press of the trigger button sends an electric current from the hilt down the filament to the small knob attached to the end. This current magnetizes the hilt and the knob at opposite polarities, and due to the strength of the field, the knob is violently repelled by the hilt. This forces the knob out and away, extending the invisible filament to its full length. As long as the device remains magnetized, the filament remains taut, under high tension. A second press of the trigger demagnetizes the sword and retracts the filament and knob back

into the hilt. The sword's power source is a sealed radio-isotope battery, similar to the systems that power deep-space probes. It will power the sword for several years of use. One employs the whipsword as a melee weapon, like a rapier. Like the garrote, it always inflicts lethal damage. Because the mono-molecular filament is so hard to see, a +1 modifier is assigned to Dodge attempts.

Laser Electroshock Pistol

In certain circumstances, the ability to pull punches, to stun instead of kill, is necessary, and the laser electroshock pistol gives the elite that option. Based on technology invented in the late 1990s, the electroshock gun is about the size and shape of a 9mm automatic pistol. When the trigger is fully depressed, the gun projects an invisible beam of ultraviolet laser light that ionizes the air along the path from gun to target. This channel of ionized air is as electrically conductive as copper wire. After a millisecond delay for the ionization channel to stabilize, the gun charges the channel with pulses of electric current which surge across the channel as long as the trigger is depressed. There is a thumb-wheel for adjusting the intensity of the electric shock. The low setting causes muscular contractions that stun the target. The medium setting can knock the target unconscious. The highest intensity will almost certainly cause death by stopping the target's heart. Although body armor and other non-conductive materials can block the gun's beam, it easily penetrates ordinary clothing. The gun has a second dial for adjusting the intensity of the laser beam. At the minimum beam intensity, the pistol has a range of up to 150 meters. When set to maximum, the gun can open a channel to targets up to 500 meters away. There is also a switch to enable and disable the laser sighting mechanism. When enabled, a half-press of the trigger causes the gun to project a visible-light laser beam that places a bright red dot at the location where the shock beam will hit. The pistol's power source is a miniaturized electric fuel cell built into the grip. Standardized fuel modules can be swapped in and out, as one would replace the clips in an ordinary gun. Each clip holds enough fuel for approximately five minutes of continuous beam at the lowest range and shock intensity settings. Using combinations of higher settings will decrease the charge lifetime proportionally. When the switches are both set to maximum range and maximum electric charge, even a full fuel clip will power less than 10 seconds of beam time (about two shots).

Maser Gun

The maser, the predecessor to the laser, was first developed by scientists in the 1950s. Over the years, designs have been refined, until now, in the Nova Age, the maser has come into use as a particularly efficient "death ray." The standard maser gun operates on the same general principles as the microwave oven. Microwaves are generated at a frequency tuned to cause specific atoms or molecules to resonate. The most com-

mon setting resonates with the hydrogen atom, which is a part of every water molecule. When water is exposed to these tuned microwaves, its molecules are induced to vibrate. This vibration causes friction, which heats the water, along with any object or substances containing it. Since living things are formed mostly of water, exposing them to high-power tuned microwave radiation will inflict severe damage. Their tissues are literally cooked from the inside out. Although the standard maser gun is tuned to emit a beam that heats water as described, different models have been designed that are tunable to other frequencies. These alternate frequencies can be used to dissociate or burn through other kinds of substances, such as woods and plastics. Coherent microwaves have a longer range than laser beams and are virtually immune to fog and dust, and at the standard frequency, most materials are transparent to these waves (though the beam can be easily blocked by metal). Because of the high power required for the instant lethality that is the whole point of the maser gun, most units are designed as two-part systems. The maser beam is generated and emitted by a hand-held pistol. This unit is connected via cable to the power source, which is worn either around the waist or in a backpack. The power supply has the capacity to generate 10 to 15 minutes of continuous beam before being depleted.

Railgun

The basic principles of the railgun are simple, consisting of two parallel electrically conductive metal rails, an electrically conductive projectile in physical contact with both rails and a source of electric power. When a voltage is applied across one end of each rail, the current flows across the projectile to complete the circuit. The flow of current generates a magnetic force on the projectile, in a direction parallel to the rails. The higher the current, the greater the force. This force causes the projectile to slide along the rails and out the end of the gun. Only the length of the gun and power of the electric charge limit the speed at which projectiles can be fired. A gun with a five-meter barrel, suitable for mounting in a large ground vehicle, can achieve muzzle velocities up to four kilometers per second, which is four times the speed of a high-power rifle bullet. Smaller one-meter versions, the size and weight of more ordinary rifles and machine guns, can still produce velocities of over two kilometers per second. The standard projectile used in hand-held railguns is a one centimeter carbon lattice sphere enclosing a solid iron core. Alternatively, the gun

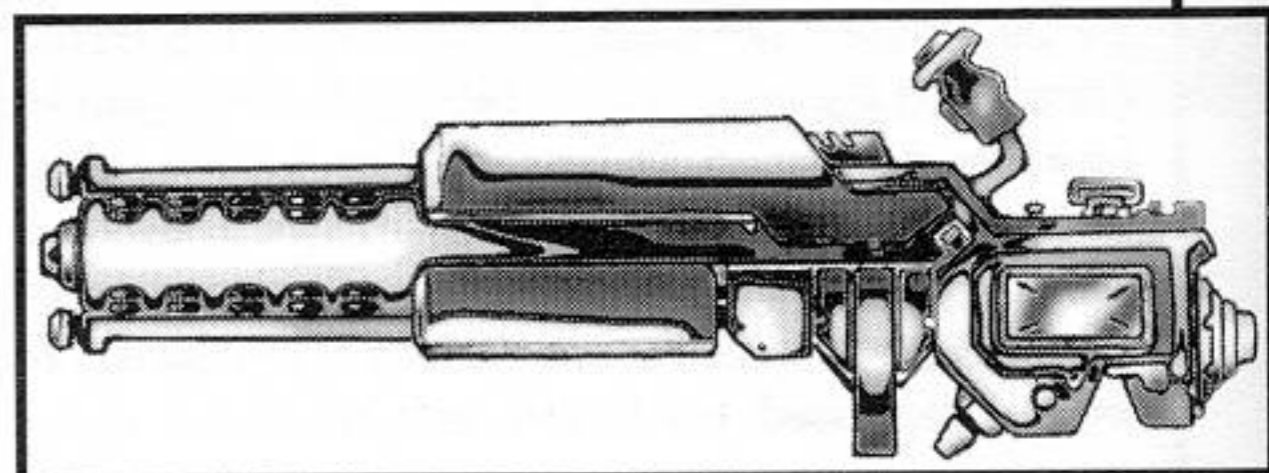

can be loaded with pellets containing many thousands of tiny iron-ceramic beads. When this ammunition is fired, the enclosing lattice disintegrates almost instantly, leaving a hypersonic shotgun spread that deposits its kinetic energy over a much wider area than the standard solid pellet. The handheld models use the same standard powerpacks as other fuel cell powered electric weapons, such as the shock pistol. Capacitors, like those that power a xenon camera flash, are used to provide the huge instantaneous current needed for a shot. These capacitors must be charged each time the gun discharges. The handheld version can charge quickly enough for a rate of fire of up to two rounds per second. A single clip contains 20 of the carbon-iron projectiles. Each powerpack will provide enough charge to shoot off up to two ammo clips. After about eight clips, the rails must be replaced. The large vehicle-mounted railgun fires five kilogram iron projectiles. These guns have the advantage of more room for carrying ammunition and a larger power source, so their limitations are rate of fire and service life. They can fire a maximum of 10 rounds a minute, and their rails must be replaced after a total of about 500 rounds.

Ultra-machine Gun (BFG)

There are moments in combat when brute force is the best solution to a problem. The United States Air Force thought so when it commissioned the design of the A-10 close support aircraft in the early 1970s. Although it could also carry standard rockets and bombs, the A-10 was designed around its primary weapon, an amazing 30mm seven-barrel Gatling gun that fired 6,000 depleted-uranium bullets per minute, or 100 rounds every second. Tanks in the line of fire would be shattered. Anything weaker would be obliterated. Novas with Mega-Strength can make effective use of their muscle by carrying one of these formidable weapons. The latest engineering advances and new heat-resistant metallic-ceramic materials have increased the rate of fire to 150 rounds per second without danger of melting the barrels. The triggering mechanism is designed to meter out 25-round bursts per standard squeeze. If you press the trigger fully, the gun will fire continuously at its full rate of fire until the magazine is depleted. The useful range is about 250 meters. The ultra-machine gun is about two meters in length and one-half meter in diameter. It has a simple sighting mechanism and a stock for bracing against the shoulder. Without an ammunition clip attached, the gun alone weighs 500 kilograms. A standard ultra-machine gun clip contains 500 rounds, is about one cubic meter and also weighs about 500 kilograms. Spare clips

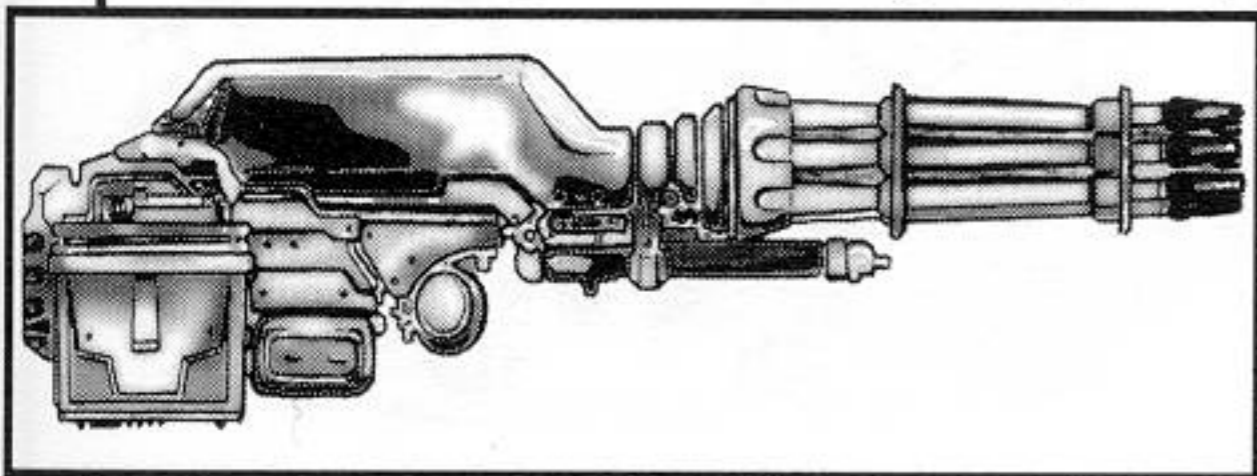

can be carried attached to belts or in a backpack. Please note that a Mega-Strength rating of 2 or better is required in order to use this weapon at all. In addition, Mega-Dexterity of 1 or better is required in order to actually aim and hit targets with any precision, (i.e., without Mega-Dexterity, the player incurs a +4 modifier to the difficulty to hit a target).

Invisibility Suit

Minimum DeVries Backing: ••

This full-body suit, including hood and facemask, is made of a specialized composite variant of vitrium glass and synthetic eufiber derivative. The substance is spun into superfine optically perfect fibers and then knit into a fabric of fantastically complex mathematical precision and intricacy. The fibers in each part of the suit are arranged such that they conduct and redirect light rays so precisely that the light appears to pass directly through the wearer. When the suit is folded up awaiting use, the cloth appears like the finest silver lace, but once the suit is donned and the fibers attune to their designed shape, the wearer appears to fade to a shimmering outline and then to nothing at all. If the wearer does not remain motionless, the shimmering outline will faintly reappear. In gameplay, treat this device as the quantum power Invisibility, but limited to the true visible-light spectrum. In addition, spending Willpower cannot augment its effectiveness, nor does it cost any quantum points to use. To detect the wearer, roll Wits + 2 if the she is motionless and Wits + 1 if she is moving, and add a number of automatic successes equal to the wearer's Quantum rating, since the eufiber derivative holds its shape with greater precision when in the presence of higher quantum.

Smartweb

Minimum DeVries Backing: ••

Some missions require that living targets be captured unharmed. Smartweb netting, developed as part of the DeVries laboratories nanotech research program, has been found to have just the capabilities needed to subdue and control most novas without inflicting any permanent damage. A smartweb is built from fibers and hub modules, connected in a lattice. Each hub is connected to between three and eight other hubs via specialized polymer fibers. Each hub contains actuator machinery for adjusting the length and tension of each fiber link, a computer processor and a tiny rechargeable electric power source. The hub computers communicate with each other by passing data back and forth through the net fibers. The net as a whole acts as a communications antenna, which is used by the net both to receive commands from its operator and to transmit and receive radar signals that the net uses to sense its environment. The hubs can coordinate to manipulate the shape and size of the net with great freedom. With all fibers fully relaxed and at maximum extension, the net is a large open lattice of many square meters. When the hubs are commanded to do so, they can retract themselves down to a

close-packed polyhedron vaguely resembling a rounded silver pineapple. It is in this retracted form that a smartweb net is loaded into its shoulder-mounted launcher. After sighting and aiming, the operator triggers the launcher, which uses compressed gas to propel the web to a range of up to 25 meters. Sensing its approach to the target, the net deploys and wraps itself around the target. The net senses struggle and contracts itself as needed to maintain control. The main limitation of a smartweb net is the endurance of the hub powerpacks. A fully charged smartweb net has about one hour of power at average usage level. If the net has to compensate more forcefully, such as when containing the struggles of an enraged nova with Mega-Strength, it will certainly deplete its power much more quickly. At constant full power output, a net's batteries will die after no more than 10 minutes. Although its fibers are extremely strong, the fibers alone are not the explanation for a smartweb net's power to subdue. By repeatedly relaxing and tightening in response to the target's thrashing, the net makes the target more likely to tire himself out before he's able to get a good enough grip to have leverage sufficient to sever even a single strand. Of course, some novas will possess sufficient Mega-Strength (three or more dots) to snap the web with a shrug. Once a smartweb entangles a target, it deals 1d10 of bashing damage every other turn until deactivated or until its power depletes. In order to break out of a smartweb, a target must either wait until the web runs out of power or destroy it by inflicting at least 25 damage successes, at +2 difficulty.

Brain-implant Data Connection

What if you could instantly know the answer to any question you could think of, as soon as you thought of it? A data-net implant will give you this power. The simplest version provides a simple one-way silent distress call capability. A more capable version allows full multiway communication between members of a team. The most powerful and most expensive form of implant establishes a full OpNet connection inside your head. If any communication implant is installed in a nova who possesses Mega-Wits, it can interact with this ability to super-encrypt the signals to the point of guaranteed unbreakability by baselines. A full OpNet connection can only be installed in a nova possessing both Mega-Intelligence and Mega-Wits. Without these capacities, he would not be able to process the enormous flood of information flowing through such a channel. All of these implants are surgically installed. The low-end distress call version is installed in a relatively simple procedure. The device, which is about the size and shape of a watch battery, is inserted into a cavity hollowed out of the mastoid bone behind one ear. The interpersonal communication version requires devices in both mastoid bones, plus an antenna connecting them implanted up and over beneath the scalp. The full OpNet connection requires

the communication implant plus serious open-skull brain surgery to install the transceiver at the base of the brain pan. Once installed, the implant has a power-supply lifetime of 10 years. There is no way to replace its power supply without additional brain surgery. The basic distress-signal implant requires two dots of Resources, the communication version requires three, and the full OpNet implant requires six.

Mood-control Helmet

Minimum DeVries Backing: ••••

When you need to interrogate a prisoner, you will find that the answers come more readily under the influence of this device. It is a fine lattice of electric wires that fits closely around the subject's skull. The helmet is specifically designed to leave no traceable permanent physical damage. Once placed on the subject and activated, the helmet sends out precisely designed energy pulses that interact with and modify the wearer's brainwave activity. The easy-to-use control system provides exact manipulation of the subject's mood. The most commonly used setting sets up an automatic feedback with brain activity to create and maintain a mental state of perfect calmness and serenity in the subject. In this state, he is free of care and anxiety and much more willing to answer questions posed to him. Under manual control, the helmet can freely modify all of the subject's mood parameters, and thus becomes a capable torture device. You can submerge the subject in an ocean of depression so deep that, if unrestrained, he will attempt to take his own life. A more direct approach is to fill the subject's

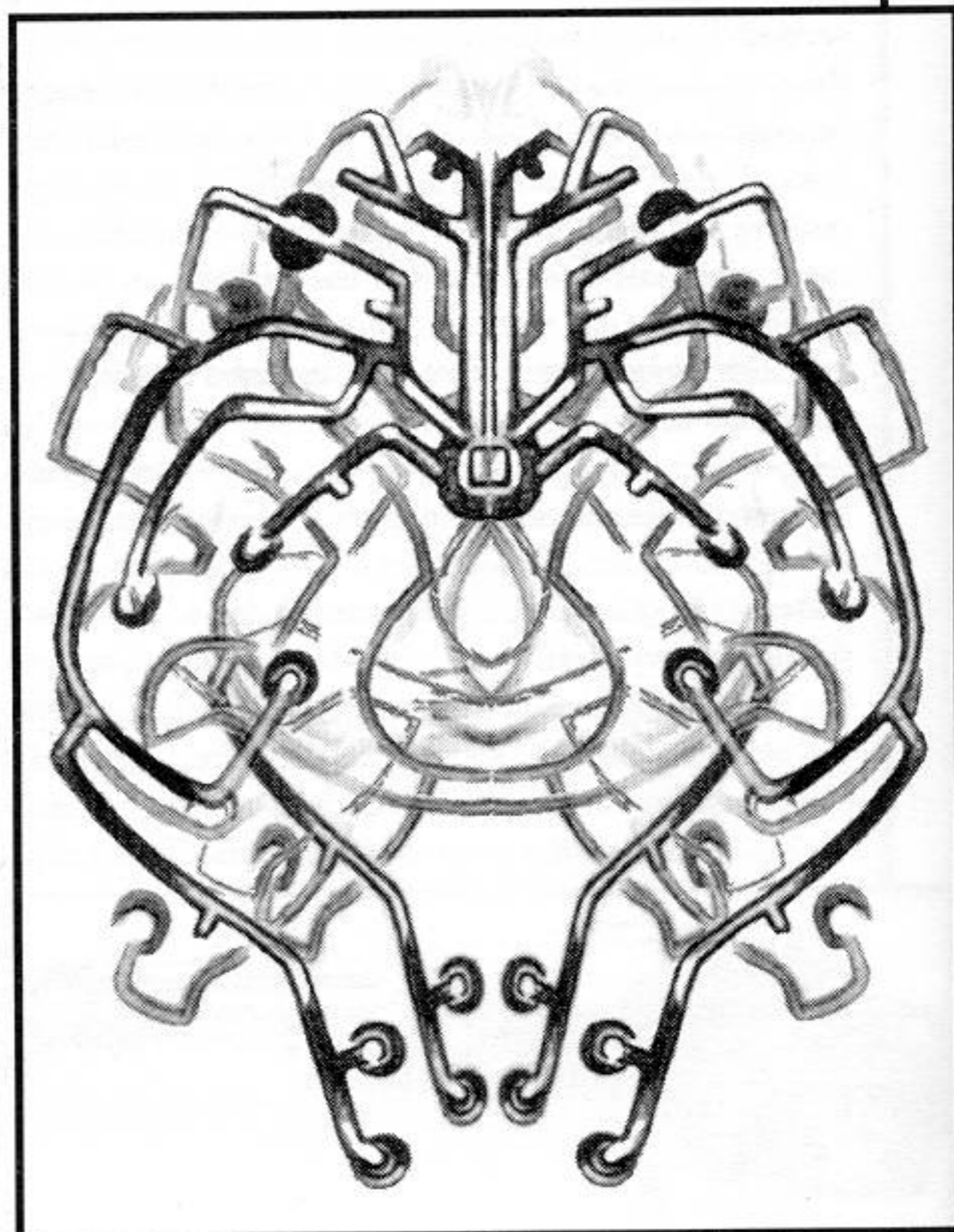

consciousness with pain of such intensity that prolonged exposure will induce psychosis. An even more insidious approach is to manipulate the pleasure centers. Enough exposure to the profound euphoria that this device can induce can permanently addict the subject. His will to resist will be broken, and he will do virtually anything you ask in return for a pleasure reward. Treat the helmet's effect as the quantum power Domination, with a dice pool equal to twice the character's Backing rating with DeVries. The helmet's rechargeable power source will run down after about one hour of continuous use.

Surveillance Robots

Minimum DeVries Backing: ••

The fulfillment of the requirements an nova elite's contract will often require detailed and painstaking reconnaissance. Various robotic mechanisms have been developed to assist in such surveillance. Each of these designs can operate either autonomously or via remote control

Urban Infiltrator

This unit is intended for use in an urban environment of streets, buildings and other structures. It can hover or move in any direction in all three dimensions at up to 100 kph. It can move slowly down a street or alley, taking cover between the buildings, look around the corner and relay any information its sensors de-

tect. The infiltrators are designed in a donut shape one meter in diameter and about one-half meter in height. Within the open core of the donut are mounted two counter-rotating propeller fans, which provide the unit's lift and propulsion. The unit runs on fuel cell electric power. Carrying only sensing gear and no weaponry, the infiltrator can fly to destinations as far as five kilometers away while still having 12 hours of power to remain on station. With weaponry installed, the unit's battery life is reduced by half, but it becomes a potent offensive/defensive platform.

What is a fuel cell?

The concept of the electrochemical fuel cell was originally developed in the 1960s to provide electric power for the first manned spacecraft. It was chosen because it produced enormous amounts of power in proportion to its size and weight because the only fuels it needed were oxygen and hydrogen, which were already being used for rocket fuel and because its only waste products were heat and pure water, a substance that was also needed onboard a spacecraft. You can think of a fuel cell as a battery that will never lose its charge as long as you keep feeding it fuel. Like a battery, a fuel cell has both a positive pole, called the cathode, and a negative pole, called the anode. Within the fuel cell, the anode and the cathode form two chambers separated by a thin barrier, called a proton exchange membrane or PEM. The inner part of the anode is coated with a catalyst element. When hydrogen flows into the anode chamber, the presence of the catalyst causes the hydrogen atoms to split, or dissociate, into two electrons and a proton each. The electrons then flow from the anode into an electric circuit attached to the cathode, while the protons pass through the exchange membrane over to the cathode chamber. In the cathode chamber, the protons combine with oxygen atoms and the electrons returning from the external circuit to form water molecules, along with some heat. It is the flow of electric current in the circuit between the anode and cathode that can be used to perform useful work. Since a single cell produces about 1 volt of power, multiple cells are connected in series to form a fuel cell stack that produces the required wattage for a particular application. Until the end of the 20th century, the most important obstacle to wide-spread adoption of the fuel cell was the extremely high cost of the required catalyst, since the only one known was platinum, a metal rarer and costlier than gold. However, the Nova Age has seen the discovery of other catalysts, and to great breakthroughs in miniaturization and compact fuel storage, making the fuel cell the ideal choice for providing silent, steady and portable electrical power. Additional engineering breakthroughs, beginning in the late 1990s, have led to refuelable alcohol-powered fuel cell power packs no larger than the familiar 20th Century D-cell battery.

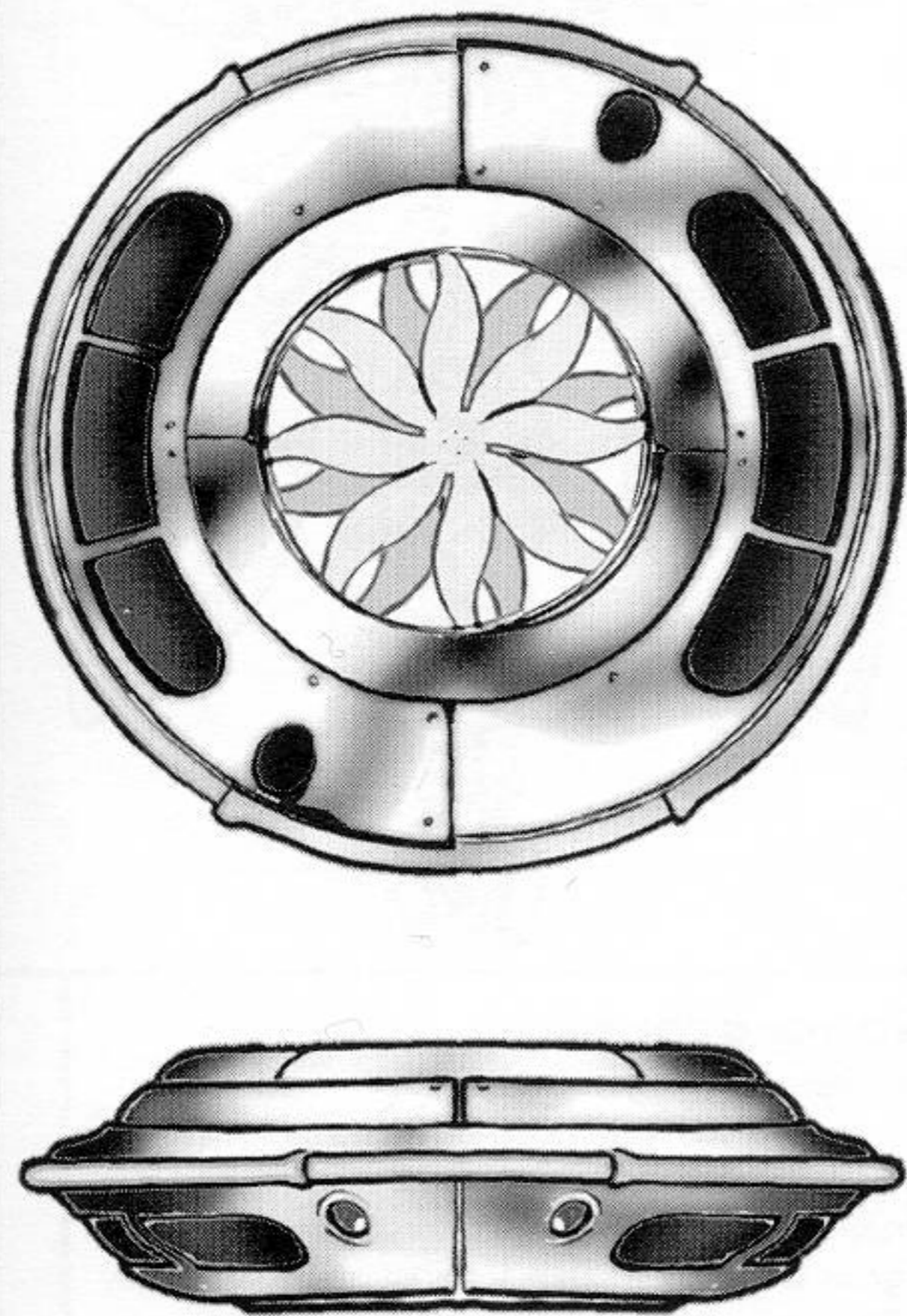

High-speed Stealth Explorer

Minimum DeVries Backing: ••

Some missions require that as much territory as possible be explored as rapidly as possible. This tiny airplane is ideal for accomplishing such a task. It is a disk-shaped flying wing, 15 centimeters in diameter and a few centimeters thick. A miniaturized hypercombustion engine powers its tiny pusher propeller. It can reach speeds of 300 kph or higher and has a range of 10 kilometers. Due to its rounded shape, tiny size and non-metallic composite structure, the explorer is invisible to radar. It uses its on-board global positioning receiver to navigate and can carry up to one-half kilo of sensing gear or other cargo.

Nanosects

Dr. Alinsky's recent fascination with nanotechnology has produced a series of nanotech insects, or nanosects as she calls them, that represent the direction she hopes to take DeVries' research and development division in the next decade. While the initial versions were largely unstable, most of the kinks have been worked out, and nanosects have proven to be popular with elites.

Nanotech Mosquitoes

Minimum DeVries Backing: •••

These tiny robots can fly, maneuver, hold position and attack. Different versions utilize a myriad of miniaturized sensing devices, and all of them have built-in computing power. Nanotech mosquitoes can be equipped to deliver drugs or poisons by "stinging." A single nano-mosquito is roughly the size and shape of a mustard seed with wings. By themselves, these devices are essentially powerless and defenseless. They are, however, designed to be deployed as part of a "swarm." The "mosquitoes" pool their computing resources through radio communication, so the larger the swarm, the smarter it is and the greater the complexity of the tasks it can carry out. The most obvious use for these devices is for deployment as a defensive perimeter. Swarms can be released and directed to hold position at various elevations around a secured area. When the perimeter is breached, they can do as little as send an alert signal or as much as attack the intruder and sting her to death. Swarms can also be released directly as an offensive weapon during a fight. As manufactured, nano-mosquitoes come in small canisters, each packed with 1,000 bugs. The central control unit can be a standalone handheld device, or it can be integrated into a helmet display or vehicle control system. Once deployed, the average lifetime of an individual nano-mosquito is about six hours. When a bug's power runs out, it falls to the ground, and the polymers out of which it is made begin to rapidly decompose. After less than a day, there is nothing left but plastic dust. A nano-mosquito controller costs three dots of Resources, while canisters run two dots each.

Robotic Dragonfly

Minimum DeVries Backing: •••

Insect wings are the most efficient means of flight yet discovered, with the wings moving at 20 beats per second and the tip of each wing tracing a figure-eight pattern in the air. This pattern of motion creates a lengthwise spinning vortex along the leading edge of the wing that doubles or triples the generated lifting power over a wing that just passes directly through the air. Once the mystery of insect flight was solved in the late 1970s, it was only a matter of time before artificial insects were designed and built. One particular form, the robotic dragonfly, has come into use by DeVries for covert operations. Each unit is the size and shape of a stylized dragonfly. It has a five centimeter long cylindrical body and a wingspan of eight centimeters. Within the body are contained the wing actuators, the miniature power source and the sensing devices. The robotic dragonfly flies by flapping its wings and makes no more noise when doing so than a living insect. Because it is so unnoticeable, it can fly through doors and open windows into buildings. Once inside, it can perform a search and then retreat, or it can hide and relay back to its controller everything that happens within its field of view.

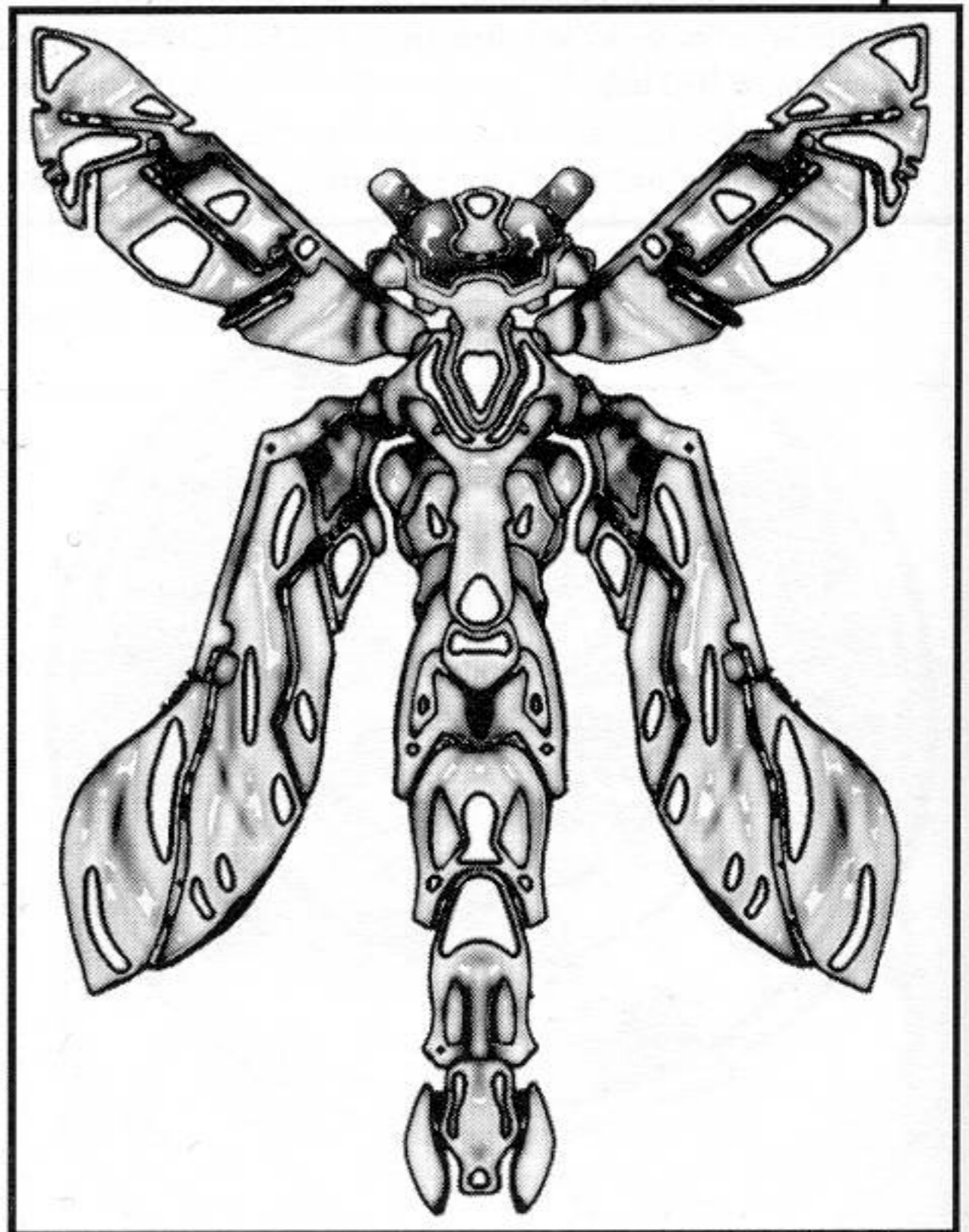

Nanarachnid

Minimum DeVries Backing: •••

Another mechanism derived from a design evolved in the arthropod world is the robotic spider. Available in versions as small as five centimeters in diameter and as large as two meters, this automaton moves by actually walking on its eight multi-jointed legs. These devices are

best used in areas where the terrain would block the use of a machine running on wheels. A robotic spider can pick its way through rubble and can even creep up and

down stairs. The miniature versions carry only sensing apparatus, but the large two-meter versions can carry and use such weaponry as guns and rockets.

Melee Weapons

Weapon Type	Damage	Str Min	Str Max	Conceal	Mass	Cost
Carbon-fiber garrote	Str+10d10 L	••	Mega••••	J	0.25	••
Whipsword	Str+10d10 L	••	Mega••••	J	2	•••

Damage: Indicates the damage dice pool for the weapon.

Str Min: Indicates the minimum Strength required to wield the weapon in question.

Str Max: Indicates the maximum Strength with which the weapon the weapon can be used effectively. Characters with higher Strength will break the weapon on its first use, though they can "pull" their blows to the Str Max in order not to break the weapon.

Concealment: P = Can be carried in a pocket; J = Can be hidden in a jacket; T = Can be hidden under a trenchcoat; N = Cannot be hidden on a person at all.

Mass: Mass of the weapon in kilograms.

Cost: Value in Resource dots.

Ranged Weapons

Type	Acc	Damage	Range	Mnv	RoF	Clip	Conc	Mass	Cost
Laser electroshock pistol	+2/+5(1)	(2)	(3)	Sa Ms Tw St	(4)	(5)	J	0.5	•
Maser gun	+3	10d10 L	750	Sa Ms St	(4)	(6)	T	3	••
Railgun (small)	(7)	(8)	750	Ms St	6	20(9)	N	8	•••
Smartweb	0	n/a	25	n/a	1	1	N	3	••••
Ultra-machine gun*	0/-3(10)	15d10 L[12](11)	200	Sa AF St	(12)	500	N	1000	•••••

* minimum strength of Mega•• required to wield this weapon

(1) +5 when laser sight enabled

(2) Low-as Stun Attack 5d10, Medium-as Stun Attack 10d10, High-5d10 L

(3) 75/150/250m

(4) continuous beam, but treat as up to 3 shots per turn

(5) continuous beam: Low-100 turns, Medium-25 turns, High-3 turns

(6) 250 turns of continuous beam

(7) +2 using solid iron spheres, +6 using hypersonic shotgun shells

(8) 11d10 L using solid iron spheres, 9d10 L using hypersonic shotgun shells

(9) one powerpack per two clips, weapon must be overhauled after a total of eight clips fired

(10) -3 unless user has Mega-dexterity of at least •

(11) per 25-round burst

(12) a single 25-round burst or 450 rounds if trigger held down

Heavy Weapons

Type	Acc	Damage	Range	RoF	Cap.	Mass	Cost
Railgun (large)	+2	20d10 L [17]	1km	(1)	100(2)	1500kg	•••••

(1) one shot every other turn

(2) weapon must be overhauled after a total of 500 rounds fired

Acc: Accuracy indicates the number of dice added to the operator's dice pool.

Damage: Indicates the damage dice pool for the weapon. B: bashing; L: lethal; S: special, see weapon's description for details.

Range: Practical range of the weapon in meters.

Mnv: Maneuvers lists special attacks available.

RoF: Rate of fire, the number of shots that can be made in a turn.

Clip: The number of times a weapon may be used before reloading.

Conc: Concealability of the weapon. J: May be hidden in a jacket; T: May be hidden under a trenchcoat; N: May not be concealed at all.

Mass: The weapons weight in kilograms.

Cost: Represents the Resources needed to purchase the weapon.

n/a: Not applicable. The trait has no relevance for this particular weapon.

DeVries Briefing Letter

From a DeVries briefing letter, dated August 19, 2010

Mr. Balinofsky,

I just finished reading your detailed critique of the original plan to infiltrate the compound. I absolutely agree that their defenses have turned out to be rather more formidable than we first understood. However, I have some good news for you. Our tech people have come up with an idea so crazy it will probably work perfectly. The people inside can't possibly be expecting anything like it. I don't know how much you may already know about the latest advances in tunnel-boring machinery, but they are quite impressive. The lovely and talented Ms. Alinsky has come up with a contraption that can melt its way through solid rock. It only goes about a meter a minute, but it can keep going for as long as you give it fuel. Because the rock is denser once it's been melted and re-solidified, there's no need to get rid of any debris. The only downside is getting rid of all the heat that is generated, but we think we've got that part figured out. What we're going to do is start boring a tunnel from a secure location on some land we own a few kilometers from the compound. We're going to keep melting our way until we're up underneath where we know they're keeping the stuff. Because the gizmo puts out so little vibration, we're sure that we'll be able to get to within a meter of the bottom of the foundation without being detected. Once the tunnel is finished, we'll withdraw the equipment, and the rest will be up to you. You should be able to get in and out before they know what hit them. Get back to me ASAP so that we can get moving on this.

Yours,
Jamison

Somewhere in the mountains of Kashmir, 2009

When the captive woke up, he was being carried. The DeVries bounty hunter had tied the man's hands and feet and had slung him over his shoulder like a package. The elite's arm was around the captive's waist, holding not quite tightly enough to hurt. They were outdoors, and it was dark. The nova was jogging uphill at a steady pace. After a few minutes, the elite stopped, pressed a button on his belt and waited. After a moment, his captive noticed a low-pitched hum coming from all directions. The sound grew slightly louder, and the captive realized that it was coming from above. With intense concentration, the captive turned his head slightly, and he saw the thing. Slowly, smoothly, it descended from the sky. Then it stopped, hanging silently in the air a meter off the ground. The ship was streamlined, its silver surface shining faintly in the moonlight. The nova pressed another button, and the outline of a door appeared in the side of the craft. The door slid in and to one

side, and a soft amber light poured out from within. The nova stepped forward and lifted the captive ahead of him as he stepped up into the ship. The nova carefully seated the captive in one of the contoured seats, fastened the restraining belts and pressed a button on the wall next to the doorway. As the door slid shut, the nova climbed forward into the pilot's seat and took the controls. The captive felt acceleration and knew that they were moving. The only sound now was the faint rushing of air outside. "Comfortable?" the nova asked, without turning his head. He spoke quietly, but with perfect clarity. "Mostly," answered the captive. "I have a headache. What is this ship?" "Mine," said the nova. "What do you think of her?" "It's very beautiful. Before we got in, it was just hanging in the air. How can it do that?" "I hate noise," said the nova, "so I made a quiet ship. She has machinery to push against the earth's magnetic field, which pushes back and gives us thrust." The captive thought about this for awhile, then asked, "When will we get to our destination?" "Soon," replied the nova.

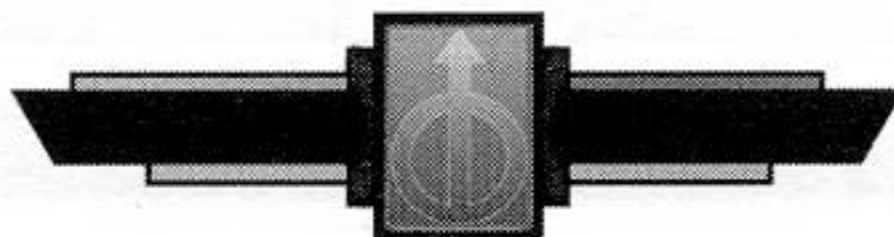

VEHICLES

Vehicle Types

Rough Terrain Walker

Minimum DeVries Backing: ●●●

Wheeled vehicles will take you to a lot of places, but they can't take you everywhere. When the terrain is too rough or too steep, you have to stop and continue on foot. Instead, why not use a vehicle that can do the walking for you? The rough terrain walker is essentially a small armored car with eight jointed legs instead of wheels. Study of the motion of insects and arachnids has led to the breakthrough in control automation that makes the walker possible. A network of sensors continuously monitors the position of the car in relation to the terrain, taking into account tilt in all three dimensions. Additional sensors monitor the position and angle of each leg. All sensor readings are fed back

to the control system, where they interact with each other and feed back to the leg motors. The control system software is so precisely calibrated and balanced that the only pilot control input is a simple joystick. The pilot pushes the joystick in the direction he wishes the vehicle to go, and the control system takes care of making each leg move in just the right way so that the vehicle responds accurately. Riders enter and exit by commanding the vehicle to "kneel." Using the vehicle on smooth and level terrain defeats the purpose of its design, but under such conditions, it can attain a maximum speed of 20 kph. As the ground gets rougher, or if the pilot commands the ascent of a slope, the vehicle's speed is reduced proportionally. When climbing the maximum allowed 60 degree slope, the walker's speed is reduced to 0.5 kph. For safety, the control system will not allow the vehicle to walk onto terrain that would be too

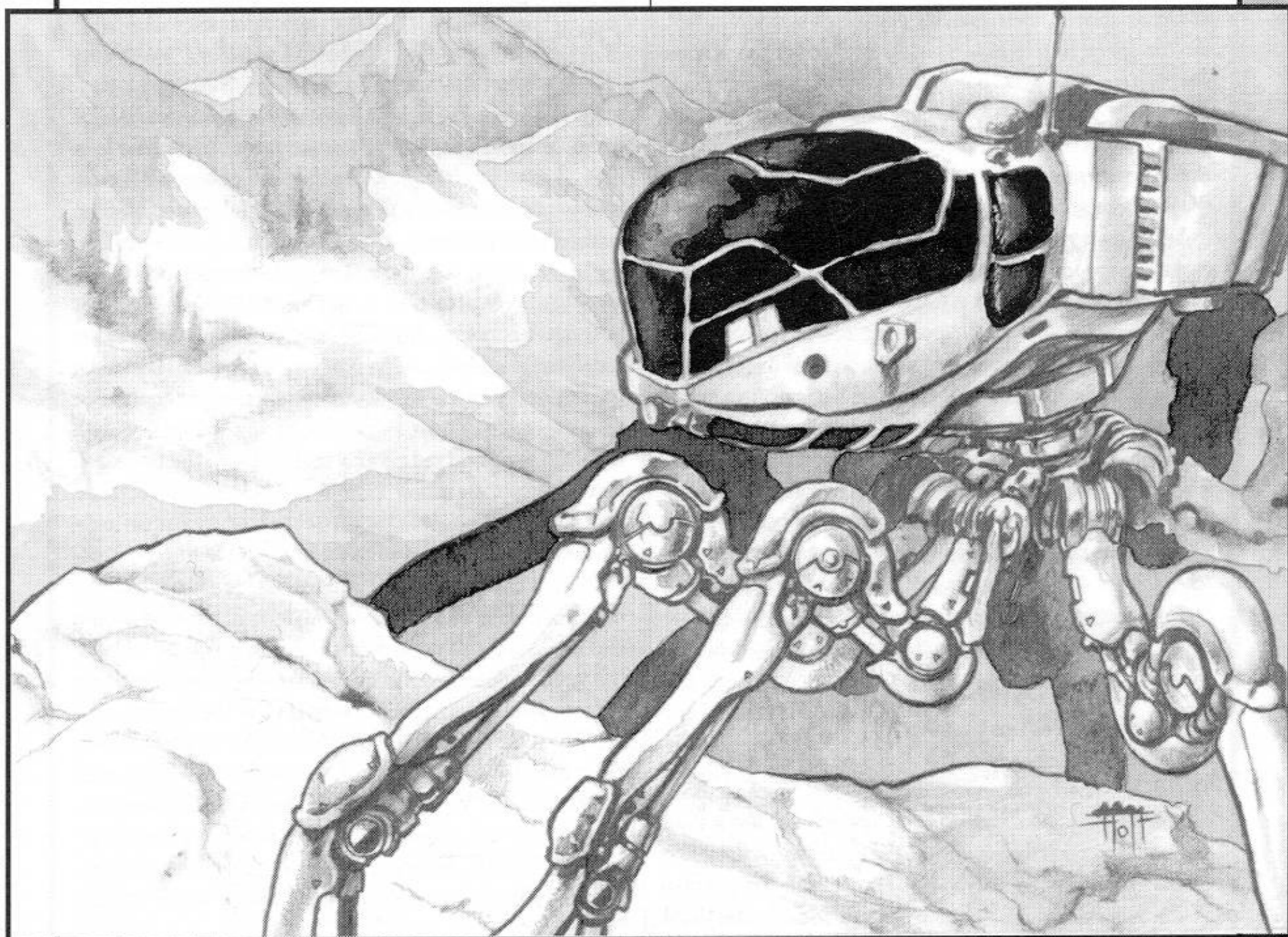

steep for stability, although the driver does have the option of activating an emergency stability override if he is determined to go in a particular direction. Disabling the stability protection system should be an action of last resort, because if the walker falls down, it most definitely cannot get up again without the help of a salvage crane.

Speedboat

Boats designed and powered for speed have been around since the *Turbinia* embarrassed Queen Victoria's navy in the 1890s by zipping and circling in and around the lumbering old battleships. Today's fastest boats are hypercombustion-powered catamarans. The twin-hulled catamaran shape offers the least resistance to passing through the water, while the hollow area between the hulls forms an aerodynamic suction effect that pulls down on the hull with increasingly greater force as its speed increases. This effect allows the boat to attain much higher speeds while still remaining on the water and under control. Without it, the boat would have a much greater tendency to launch itself into the air and be destroyed. The boats are usually between 9 and 15 meters long. The smaller ones carry only the pilot and a single passenger. The largest models can carry up to eight passengers and are frequently used to land small attack parties and then evacuate them quickly. They are propelled by hypercombustion-powered water jets, rather than propellers. These boats are incredibly agile and maneuverable when operated below 60 percent of their top speed. When pushed to higher speeds, their stability decreases steadily. In fact, the top speed is determined not by any limit of the propulsion system but by the point at which the chance of going airborne approaches 100 percent. The likelihood of going out of control is partly a factor of pilot skill but is predominantly determined by the water conditions. Choppy water is the most dangerous situation for this type of boat. Given a skilled pilot and wave heights of one meter or less, these boats can attain speeds of 500 kph on a straight run. They can still be operated at low speed in wave conditions as high as two meters but should not be exposed to conditions any more severe. The difficulty of driving a speedboat of this type depends entirely on what percentage of its maximum speed the vehicle is traveling at. Piloting rolls made while going at 60 percent of maximum speed are at a difficulty of 6; at 70 percent of maximum the difficulty is 7, up to a maximum difficulty of 10 at 100 percent of the maximum speed. Failure indicates the boat has nearly become airborne and the pilot loses control. At these speeds, this means that the boat breaks up in the water and passengers take 20d10 of bashing damage from impacting the water at those high speeds.

Personal Submarine

Minimum DeVries Backing: ••

In the first decade of the 21st century, the submarine was re-imagined. The breakthrough was to conceive that a submarine could be designed to fly underwater like a stunt plane flies through the air, with all the accompanying advantages of speed and maneuverability. In the Nova Age, vitrium is the hull material of choice for personal waterflight

submersibles. With vitrium, you can use what are effectively sophisticated glass blowing techniques to mold an entire hull as a single unit without seams or joints. Even after drilling the necessary holes for control, power, air and water lines and for the entry hatch, the one-piece vitrium hull remains extremely strong. The most commonly used and least-expensive version has a hull thickness of two centimeters. This allows the vehicle to safely attain depths of up to 300 meters. At greater cost, hulls have been fabricated to a thickness of five centimeters. Such a vehicle could dive to 11,000 meters, which is deeper than any part of the Earth's oceans. The waterflight submarine hull is vaguely egg-shaped, five meters along the long axis and two meters across. It has two pairs of short "wings," one on each side near the front and the other pair near the rear. Intakes for the water jet propulsion system are mounted above and below the rear. The main propulsion jet is centered in the rear end, but there are additional jets at the end of each wing. When operated at its top speed of 120 kph, the waterflight submarine has an un-refueled endurance of about two hours, a time which triples if the pilot stays below 100 kph. The fuel-cell powered propulsion and life support machinery is mounted in a compartment at the rear, below the pilot's feet. The pilot occupies the rest of the hull, in a comfortable prone position, his arms free to operate the controls and instruments. Once strapped in, he finds that his vehicle acts like an extension of his own body, enabling him to move freely in three dimensions as if he were a dolphin.

VTOL Super Fighter Jet

Minimum DeVries Backing: ••••

The super jet fighter can carry either a single pilot or a pilot and a weapons/reconnaissance operator in tandem. It can sustain a level-flight speed of Mach 2.5 over an un-refueled distance of over 1500 kilometers. When pushed to its maximum speed of Mach 3.5, it can still go for up to 500 kilometers. These enormous speeds are often sufficient for outrunning most enemies. If a fight becomes necessary, the VTOL jet provides unsurpassed aerobatic capabilities for winning dogfights. The main thrust nozzles of its two hypercombustion jet engines can be vectored up, down, left and right. In combination with the main wing and tail control surfaces and the two small canard wings on either side of the nose, this vectored thrust makes it possible for the jet to literally stop in mid-air and instantly move off in a completely different direction. It can perform 90 and 180 degree turns within a distance of less than twice its own length, all while aiming and launching deadly ordnance. When it is time to land, the fighter doesn't even need a runway. Two additional vectored thrust nozzles can be opened at the front of each engine. When all four nozzles are tilted to point down, their thrust will fully support the aircraft's weight, thus providing a full VTOL (Vertical Takeoff Or Landing) capability, like the pioneering British/American Harrier jet of the late 20th century. The jet's extraordinary maneuverability is of crucial importance during aerial combat

with a nova. As long as the jet keeps below its safe speed, it can perform its darting directional changes without any difficulty rolls, while the nova must roll Dexterity + Hypermovement. Unless the nova has a truly stupendous Hypermovement rating, she will be at a disadvantage.

Collapsible Ultralight Airplane

Among the numerous astonishing achievements of materials science in the Nova Age has been the discovery of many new composite structural materials. These new substances make possible the design of vehicles which are orders of magnitude lighter in weight, yet as strong as or even stronger than the designs they replace. One of the more exciting offshoots of this composite materials revolution has been the evolution of the ultralight aircraft. The first ultralights were built in the 1970s by attaching chainsaw and motorcycle engines to hang-glider designs built from parachute cloth and aluminum tubing. These machines were small, lightweight and easy to fly but difficult to disassemble for storage and transportation. Today an elite operative has available a variety of fully collapsible ultralight designs. The most sophisticated version occupies less than one cubic meter when fully collapsed and weighs about 50 kilograms, including engine and fuel. Such a design is suitable for carrying in a backpack. In order to prepare the vehicle for use, the user must first unfold the delta-wing airfoil from around the power unit until it snaps into the open position. Next, the user snaps the pusher propeller onto its shaft. The entire assembly can then be lifted into place on one's shoulders. Once the various harness straps are adjusted and tightened, the final step is to unfold and snap into place the two control levers. Since an electric fuel cell powers the vehicle, all one needs to do to take off is to slowly advance the motorcycle-style throttle while running forward at a slow jog. Once airborne, the vehicle can achieve a safe sustained airspeed in level flight of about 120 kph. Due to the high lift generated by the advanced airfoil design, one is well advised to take advantage of air currents in order to extend the life of the power pack. Given an average effort at this sort of conservation, a range of up to 200 kilometers should be possible before running out of power.

Tunnel Borer

Minimum DeVries Backing: ●●●●●

The best route into a defended area is rarely the most obvious one. Boring a tunnel far within the perimeter will sometimes be the only way to circumvent the defenses. Considered purely as a vehicle, the melting tunnel borer is highly impractical. While it is an enormous snub-nose bullet, 5 meters in diameter and 20 meters in length, it can only carry one passenger. It has a maximum forward speed of one meter per minute. However, this speed can be sustained while tunneling through solid rock. The borer works by using hydrogen flames to melt the rock around its shaped nose section. After being melted, most forms of rock become much denser and take up much less space. Since it works by creating new lava, the borer cannot melt through basalt or other forms of solidified lava. As the nose pushes

forward, the melted material is squeezed out, around and past the nose to the next section, which cools and solidifies the lava, shaping it into a smooth, solid and strong tunnel lining. At the rear of the borer is the control cab, with navigation devices and a seat for its operator. The borer is carried on multiple sets of small, electrically driven metal wheels around and under the rear section. Because it requires such very large quantities of hydrogen fuel and cooling water to perform its task, the tunnel borer is not self-contained; it is dependent on umbilical lines for fuel and coolant recirculation. These umbilicals trail from the borer back along the completed tunnel to the base units, which are located outside. One of the base units is essentially a giant liquid hydrogen tanker truck, which can hold enough fuel to power the borer for about one hour. The other performs the all-important task of dispersing the heat generated by the boring process. There are two versions of the radiator unit. If the operator starts the tunnel near a body of water, she can choose the version that uses water to cool its radiator coils. This version is more efficient and much quieter than the alternative, which instead uses huge fans to force cool air over the radiator. Before tunneling, the operator must have pre-determined the minimum length of the umbilicals. The borer itself can stow up to 150 meters of umbilical line. For longer tunnels, the operator can attach tenders to the rear of the borer, forming a train. Each tender unit can carry an additional 100 meters of umbilical. The line is unreeled from the rearmost tender first. When its supply is fully unreeled, a tender is detached from the train and left to stand in the tunnel while the train continues on. Once the tunnel is finished, the process is reversed and everything is reeled back in.

Levitation Flyer

Only one magnetic levitation flyer is known to exist. Its nova owner, a designer, builder and bounty hunter for DeVries, was motivated as much by aesthetic considerations as by a desire for technological excellence. His machine is a silver arrow-head, elegantly curved and tapered, about eight meters long. It operates by generating prodigiously strong magnetic fields and controlling them with exquisite delicacy and precision. These fields interact with the magnetic field of the Earth itself, pushing against it to generate all the force required to lift, steer and propel the flyer and its four passengers to speeds approaching Mach 1. The magnetic fields are generated electrically, through power drawn from an extremely efficient radioisotope generator. The radioisotope fuel source will provide enough power for months of continuous flight at top speed. Electric conductors pass throughout the flyer's hull. The pattern of their arrangement and interconnection, in combination with the cybernetic control system, provides the extraordinarily complex and exact field control necessary for levitation and propulsion. Piloting the flyer is very simple. There are two joysticks, one for controlling movement on the horizontal axes, the other for controlling elevation. The pilot can use these in combination to move the flyer in any direction at any speed or, instead, to

hover motionless at any altitude. The flyer would seem to be a flawlessly ideal form of elegant personal transportation. However, it does have a weakness. The complex arrangement of electric conductors in the hull must remain completely intact, otherwise drastic failure will occur. At best, all levitation will cease instantly and the flyer will begin to fall. At worst, the magnetic fields will become unbalanced and cause the flyer to gyrate uncontrollably or even self-destruct.

Options

Amphibious

Many land-based vehicles can be modified or re-designed to allow travel on, or even under, water. If you are trying to escape a chase, then being able to cross that river or disappear under that lake may be what keeps you alive. At minimum, the changes will involve waterproofing and adding a water propulsion system. A simple water jet motor is usually the best choice. Another way to go is to modify the vehicle's existing propulsion system to allow it to drive along the bottom of whatever river or lake needs to be crossed. This approach is best taken with larger, heavier vehicle types. Unfortunately, it costs half of a vehicle's initial value to redesign it for amphibious capability.

Autopilot

Any kind of vehicle can be modified to work on autopilot, at varying cost. Many vehicles will have such a system as standard equipment. To figure the cost to retro-fit an autopiloting system to a vehicle, divide the initial vehicle cost by three and round up.

Projectile-resistant Glass

Specifying that your vehicles windows be made of vitrium will ensure that it will take a much higher caliber of projectile to penetrate. For a flat rate of two resource dots per vehicle, you

can buy an additional 20 points of soak against bashing damage per refitted window. Once a window has absorbed its soak capacity, it shatters and is destroyed.

Stealth

Any air or watercraft design can be modified for stealth, which is the ability to avoid detection by radar or sonar. Passive stealth design involves the shape of the vehicle and the materials with which it is constructed. Certain angles and curves make the vehicle much less likely to reflect sensor beams back to their detectors, while various coatings act to absorb the radiation. A more expensive but sometimes more useful stealth technique involves adding equipment that actively broadcasts jamming signals to fool the enemy's detectors. Figure that passive stealth will add one dot of cost to a vehicle, while active stealth will cost two dots. Traveling at night, a stealth-enabled vehicle cannot be detected at distances of 500 meters or beyond (even by a nova possessing Mega-Perception, unless he achieves 8 successes).

Ejection Seat/Escape Pod

Although most useful when added to an aircraft, emergency escape systems can also be added to land and water-based vehicles. The more people an emergency escape system can save, the more expensive it will be. Some vehicle types, such as jet fighter planes, come with ejection systems standard. When the system has to be retro-fitted, it costs a dot of resources for every two passengers served by the system.

Armaments

Depending on the size of the vehicle, you can install almost any of the heavy weapons listed in the main rulebook or more exotic ones mentioned elsewhere or those that you devise for yourself.

Vehicle	Safe Speed	Max Speed	Man	Pass	Armor	Cost
Rough Terrain Walker	5	20	2	2-4	5 [10]	•••••
Speedboat	300	500	6	2-4	3	•••••
Personal Submarine	100	120	7	1	4	•••••
VTOL Super Fighter Jet	Mach 2.5	Mach 3.5	11	1-2	6	•••••
Collapsible Ultralight Airplane	120	175	5	1	0	••
Tunnel Borer	.06	.06	0	1-2	5	••••••••(1)
Levitation Flyer	1000	Mach 1	9	4	2	••••••••••(2)

(1) This gets you the borer and the two base units. Each umbilical tender costs •• extra. Refilling the hydrogen truck costs •• as well.
 (2) This is if you could convince the owner to sell or to build you one.

Safe Speed: Indicates the safest possible speed (in kilometers per hour) at which to perform maneuvers in the vehicle.
Max Speed: The highest possible speed (in kilometers per hour) for the vehicle. Maneuvers are extremely difficult, if not impossible, to perform at this speed.
Man(euver): The maximum dice pool allowable by the vehicle type. Penalties should be applied to the character's dice pool before limiting the pool by the maneuver rating.
Pass(engers): The normal seating capacity of the vehicle.
Armor: The protection afforded to passengers of the vehicle. Damage should be soaked by the vehicle before hitting any passengers. The rating in brackets indicates the minimum number of damage successes required to penetrate the vehicle's armor. This rating is reduced by the damage add indicated for heavy weapons or nova attacks.
Cost: Represents the value of the vehicle in Resource dots.

Warfare has never had so much in common with professional sports as it does now. Ever since the killing of Hiram “Slag” Goldberg by the infamous elite Totentanz in Nigeria, international conflict has devolved into something like an XWF Black Circle bout. Years later, the Slags of the world are gone; those that have survived the natural selection process of the brush wars and coups — elites like Esteban “Infierno” Caracon, Linda “Lotus Infinite” Raphael and, yes, Totentanz — rake in piles of blood-stained money as they decide the outcomes of conflicts across the globe.

The piles of weapons that the governments of the Earth have been collecting since WWII are suddenly obsolete. For getting results, an elite is better than a bomb.

In the early years of this decade, elite warfare was a boon to the impoverished dictators of the world. At the end of the 20th century, US President Bill Clinton forced Yugoslavian strongman Slobodan Milosevic to resign simply with the *threat* of missile strikes. After what some in the media called “Kosovo’s Immaculate Coercion,” the message was clear: If a nation couldn’t threaten the United States militarily, the US would blackmail it with bombs.

In the Nova Age, however, that strategy no longer works. Even the poorest nation can afford a few elites, and a few are more than enough to turn the tide of most military engagements or at least promise significant collateral damage. The Equatorial Wars of 2001 proved how costly battling elites could be, regardless of the ultimate outcome.

Two belligerent innovators can claim credit for the rise of elite warfare: Lambert Asani, president of the Democratic Republic of Congo, and Anna DeVries, founder of the DeVries Agency, a firm that represents novas for hire.

Following her own eruption, Anna DeVries revived her father’s mercenary agency Executive Actions but used novas for her soldiers. While the newly founded DeVries Agency contracted novas to assist UN peacekeepers in Eastern Europe, it wasn’t until her association with Lambert Asani, then a revolutionary seeking to oust Laurent Kabila in the Congo, that novas moved from being a threatening reserve to the forefront — indeed the critical factor — of conflicts around the world.

Indeed, the word “elite” was born somewhere within the bowels of the DeVries marketing department, and they *still* have the *chutzpah* to capitalize it, but the Equatorial Wars, which Lambert Asani precipitated with his revolution, provided the revenues for those “elite” ads that

catch every dictator’s eye. Asani conceived the tactic, DeVries (with capital from South American diamond giant DeBeers) packaged it for corporate consumption. The Nova Age was through. The Elite Age had begun.

Elites today are more than the latest innovation in warfare. They have suddenly become the thermometers of opinion on the international situation. More average Americans, following the exploits of certain elites all over the globe, now pay attention to international news — a beat that’s rarely helped to sell papers and was formerly the domain of foreign-affairs geeks and academics. Yet all this information gets sifted through a peculiar filter: Increasingly, America’s knowledge of international affairs relates to the actions of various elites in conflicts across the planet. The common man keeps up with elites, not politics. The situation in Kashmir isn’t about a multinational DMZ designed to dissuade Pakistan, India and China from full-scale war, it’s about — in the words of New Jersey kindergarten teacher Miles Holloway — “Team Tomorrow showing those Mooslum elites who the big dog is.” People seem to know the details of the Kashmir dispute as well as they know what’s happened on *Days of Our Lives*.

Following Slag’s death in 2001, Team Tomorrow became the world’s champions, elites the villains everyone loves to hate (of course, there’s good elites and bad elites and ... ah, just read Quantum Boom’s Violent Eruptions chart in the back of this issue). Is the XWF comparison sinking in yet? The Totentanz and Pursuer action figures continue to move; presumably, kids need elites for their T2Mers to battle.

From a merchandizing standpoint, elites have exploded in ways a bomb never could. Bombs don’t smile and wave to the cameras. Bombs don’t have distinctive masks that can move toys and T-shirts. Even the bombs with personality, like Fat Man and Little Boy, can’t invent insipid catchphrases like “That’s a damn fact!”

Put away your bombs, all you governments of the Earth. The Age of Elites has begun.

Better than a Bomb

How I Learned to Stop Worrying and Love the Elites

Flare, April 2011

KASHMIR

Kashmir is the most dangerous place on Earth. Two nuclear states, Pakistan and India, claim the land as their own, and no amount of reason will deter them from their ancestral claims. A third, China, is ready to bomb both countries into submission to prevent a nuclear war that could engulf all of Asia. With each passing day, the tension around Project Utopia's demilitarized zone mounts as militants in occupied Kashmir become more audacious in their insurgency. Even after two major elite conflicts that decimated this much-desired territory, no one's willing to back down. The pundits and strategists argue about which country will make the first move or is in the best position to win in a full-scale war, but only one thing is certain: The center will not hold.

Sixty Years of War

In 1947, when the former British Empire pulled out of Asia, Pakistan and India immediately went to war over Kashmir, the region between the two countries. Both nations made historical claims about why Kashmir was rightly within their borders, and three wars later, the issue remained undecided. In 1972, all the countries could agree on is that they would decide it between themselves without any international mediation.

Pakistani and Indian forces occupied their zones of Kashmir and engaged in occasional conflicts when one side crossed the Line of Control. The periodic flare-ups in Kashmir continued until late in 1999, when the current situation in the region began to take shape.

Pakistani Premier Nawaz Sharif, under pressure from Beijing and Washington, pledged to Indian President Atal Bihari Ranganath that the Pakistani army would no longer cross the Line of Control. Sharif, however, had little influence over the groups of Muslim militants that sought to oust India from Kashmir, and the fighting continued.

Despite the militants' continuation of the conflict, Sharif looked weak for calling a halt to aggression in Pakistan. The military and certain fundamentalist groups turned against him, and General Pervez Musharraf ousted Sharif late in 1999. The general vowed to reclaim Kashmir for Pakistan but soon ran into the same international pressure that Sharif faced. While the Indian occupying force still had to deal with Muslim guerillas, the Pakistani army never crossed the Line of Control.

Until 2002, that is. Musharraf owed almost 20 million dollars to a London bank and refused to pay the debt because he considered the interest that had accrued "un-Islamic." The bank sent two elites to extradite Musharraf to London to face trial; this was probably the first time a private interest employed elites against a sitting head of state. After Musharraf was removed, General Rashid Qureshi seized control of Pakistan in a military coup. Almost immediately, he sent the Pakistani army across the Line of Control.

Toppling Mt. Rakaposhi

That's when things started to get bad. With India and Pakistan nearing a full-scale war in Kashmir, both itchy to use their newly developed nuclear warheads, China stepped in. The People's Republic, increasingly paranoid about the stability of the Asian community in the age of novas, began a series of air raids on critical points that belonged to both sides — places that are now synonymous with futile bloodshed like the Shingo River and the Punch and Kulham districts. In Srinagar, 30,000 people were killed, and Mt. Rakaposhi ended up 600 meters shorter than it was before the fighting began.

Far more important to the history of warfare in the Age of Novas, however, was the use of elites by all three countries. Pakistani novas squared off against their Indian counterparts while the Exploding Heavenly Mandate, a Chinese government-sanctioned nova group attached to the People's Liberation Army, neutralized military installations on both sides of the Line of Control. With the conflict threatening to spill over into Pakistan and India, Team Tomorrow stepped in.

After wiping up what was left of the Pakistani and Indian novas, Team Tomorrow confronted the Exploding Heavenly Mandate on Hill K8, where the Chinese novas were ripping landmines out of the ground. Caestus Pax, in a well-scripted (and televised) plea, persuaded the EHM to return to China after he promised that Project Utopia would guarantee no more bloodshed in Kashmir. The Chinese, eager for stability but even more eager to avoid such a tedious international entanglement, stood down. After that, clearing away the dozen or so elites the three countries had brought in at the last minute was no problem.

Team Tomorrow kept its promise by establishing a demilitarized zone overseen by a sizeable UN peacekeeping force. Pakistan and India pulled their forces out of Kashmir. The fighting ended, and the bitching began. Both countries claimed that Project Utopia had accomplished a military takeover of a region unprecedented in history — they came in to settle the dispute and ended up claiming the region for themselves.

With the joint establishment of the DMZ by the United Nations and Project Utopia, Kashmir was divided into three regions. India and Pakistan each retained control of a ribbon of land near their borders, with the center cordoned off by T2M and a sizeable UN peacekeeping force. Although Project Utopia was notoriously evasive about exact numbers, reports generally suggested that a dozen or so novas guarded the DMZ as part of the Project Utopia-United Nations deployment.

Although the occupying force in the DMZ was ever at odds with Muslim militants that refused to be suppressed, Project Utopia's arrangement kept peace for almost four years before tensions escalated into conflict again in August 2006.



India's Utopian Whores

Two Pakistani militants opened fire in the offices of a Mumbai film company. With a body count of 26, two fugitive Pakistani terrorists and a manifesto proclaiming retaliation for the occupation of Kashmir by India's "Utopian Whores," the Indian people cried out for vengeance. With an election in the coming June, the Bharatiya Janata Party, long derided for an agenda supposedly antagonistic to Muslims, could not afford to look weak on the issues of terrorism or Kashmir. The Indian premier and BJP candidate Jasjit Nambiar ordered Column Shiva (India's answer to Team Tomorrow) to destroy key sites in Islamabad.

With the capital of Pakistan in flames, Asia was poised to become a large mushroom cloud. The General Assembly of the United Nations resounded with calls for revenge and threats of retaliation. The Chinese delegation, disgusted by the indecisive howling, walked off the floor. An hour later, Chinese novas descended on Kashmir.

India and Pakistan responded in kind, and the destruction caused by these three factions of novas made the conflagration in Islamabad look like the pop of a firecracker. China wisely ordered its Exploding Heavenly Mandate to avoid engaging any forces outside of Kashmir; the threat of the conflict spilling into India or Pakistan kept the two countries from engaging in broader hostilities.

India's Column Shiva began a series of vicious attacks on Muslim communities in Kashmir. Pakistan, with no novas to call its own, hired every elite they could find to protect these villages. Both India and Pakistan hired elites from DVNTS. The Team Tomorrow novas in the DMZ rushed in to quell the fighting.

The Team Tomorrow novas soon fell to the cosmopolitan collection of elites that descended on Kashmir. T2Ms Central, Pacific and Europe were called in to relieve the dwindling UN peacekeeping force. The list of Pakistani elites, Indian and Chinese government-sanctioned novas and T2M members that participated in the battles in Kashmir is a veritable — if bloody and destructive — who's who of novas in the early 21st century.

Three days later, the fighting had subsided; the novas from China, Pakistan and India were subdued; TV coverage of the war set new audience records and the Kashmir DMZ was re-established. No one complained that the prize over which they'd spilt so much blood, Kashmir, was now an environmental wasteland mostly unfit for human habitation.

The Current Dilemma

The current situation in Kashmir resembles the ending of a Quentin Tarantino film: Everyone's got their guns pulled; if one goes off, they all go off. None of the interested parties are willing to back down. Pakistan denies official involvement and says it can't control the militants in Kashmir, but really, the Qureshi regime is so mired in notions of the Muslim holy war that it embodies the worst stereotypes of "Islamic Fundamentalism." Premier Rashid Qureshi rose to power on the promise to reclaim Kashmir for its rightful Muslim rulers, and the day he backs

down from that promise is the day he's replaced.

Jasjit Nambiar, premier of India, labors under a similar obligation. After the terrorism of 2006, the average Indian rabidly wants Kashmir rejoined with India proper. If Nambiar appears weak on the issue of Kashmir, an issue critical to the fundamentalist Hindus that the BJP has worked so hard to court, the ruling party may soon find its control of the government upset by the rival Congress Party.

China believes that nuclear winter would complicate its inevitable ascendancy over Asia. A fight between Pakistan and India, whom the Chinese regard as fanatical rogue nuclear states, is the last thing China wants. Finally, Project Utopia must maintain its DMZ or repeat its Equatorial Wars fiasco. If it is to remain a credible force for world peace, Utopia must prevent open warfare in Kashmir or, rather, when it ignites again as it inevitably must, squelch it as soon as possible.

The DMZ

Kashmir is now, by most reckonings, a sparsely populated wasteland. Still, it's notoriously difficult to control. The token UN peacekeeping force dwindles each year as soldiers are needed elsewhere or another nation pulls out over some trivial objection to UN policy.

Of course, this force is supported by a dozen or so novas from Project Utopia, but the heavy hitters like Caestus Pax or Splash don't hang out there much. The T2M operatives in Kashmir usually come in one of two varieties: new recruits and problem cases. Newer T2Mers who have passed through the final stages of their training but still aren't ready for a position with an established T2M cell are sometimes sent to Kashmir for a remedial education in the field. Also, although Project Utopia would never admit it, those operatives of T2M that have caused their superiors some headaches (perhaps by embarrassing the Project or being notoriously hard to work with) get shipped to the DMZ for a few months until they come to their senses.

Certainly, such a precarious situation demands the attention of more experienced novas, but Project Utopia feels putting its most effective agents in the DMZ might draw "undue international focus."

For those novas relegated to duties in Kashmir, however, there's more to do than just sit around and wait for war to break out. Unless the DMZ military machinery is on alert, the days of T2Mers are filled with repairing the damage that was done to Kashmir by the fighting in 2006. Wildlife needs saving, fields need irrigating, entire villages need to be rebuilt.

Most of Project Utopia's environmental relief efforts are couched in some kind of humanitarian outreach. If novas can "win hearts and minds" by rebuilding Kashmir, they can prevent the growth of insurgent movements that work to remove Project Utopia and the UN from this contested land.

Threats to Stability in Kashmir

There are a million things that could go wrong in Kashmir. Here's a list of the most worrisome. Storytelling

the conflict over Kashmir should exploit the nerve-racking priorities of the numerous factions active in the region. The incident that precipitates another full-scale war could arise just about anywhere. Those who hope to maintain peace in Kashmir face the frustration of dealing with a multitude of X-factors.

Included with each of these threats are Storyteller ideas for elite contracts and themes for elite series.

International Misunderstanding

Remember what happened in 2006? The huge battle that ended in thousands of deaths and caused billions of dollars worth of environmental destruction was started by two terrorists going nuts in an office building. All it takes to spark fighting in Kashmir, and possibly all of Asia, is for a few individuals partial to one country to do something so outrageous that the others feel forced to respond. Even fanatical sects that have no direct interest in the struggle but are notorious for spreading mayhem (such as certain virulent strains of Kamisama Buddhism) might want in on the destruction as well. Agencies concerned with international terrorism, including the Directive and certain divisions of Project Utopia, must be particularly watchful for lunatics throwing lit matches at the Kashmir powder keg.

This tension can provide a backdrop for a series involving novas dealing with terrorism. An attack against, say, an Indian embassy doesn't just endanger the immediate victims; such attacks have larger international consequences as well. The players' novas aren't merely stopping a cell of terrorists — they may be stopping a war in Asia.

The precarious situation in Kashmir can also intensify an elites series. The willingness of all parties to over-react gives elites active in the region a good incentive to keep things quiet. Elites who act without the necessary subtlety risk sparking another war in Kashmir. Also, the likelihood of another huge conflict in Kashmir should give elites pause — they should begin to question their mercenary morality as they undertake assignments that might very well change the course of world history.

Nuclear Warfare

No, it was never an issue. Any possibility of nuclear confrontation was far, far away. Look, we're a responsible nation, and a responsible military force. We understand the thresholds.

— Chief of the Indian Army Staff, General V.P. Malik, *Newsweek International*, August 9, 1999.

Complicating the nuclear stalemate between Pakistan and India is the "Dragon's Nest." In Shiquanhe, on the Tibetan plateau, the People's Liberation Army of China has installed a gigantic nuclear missile facility at an altitude that allows it to perform surface launches all over Asia and well into Europe and the Pacific. The forbidding terrain around the facility makes it almost impossible to reach on the ground and guarantees any attack from the

air will be picked up on radar. One hopes the Buddhist temples that dot the region give those in charge of the facility a chance for the proper introspection.

Given the uncertainties of warfare involving elites, Pakistan, India or China may resort to the ultimate trump card if a battle between their novas proves indecisive. While none wants to be the country to launch first, if faced with the possibility of an intractable and volatile elite conflict, any of these nations might resort to a pre-emptive strike. There's still one reliable way to knock down a nova, and things look pretty grim.

On the upside, the world may get the best test of the "mutually assured destruction" theory of deterrence it's seen since the Cold War.

The risk of nuclear war offers plenty of thematic possibilities for an elite series. If elites are *too* effective, they risk frightening baselines, who already suffer from low self-esteem and an itchy button-finger. This really encompasses the overarching theme of **Aberrant**: In a world suddenly beset with godlike beings, how far must humanity go to protect itself?

For series that involve less navel-gazing, the nuclear situation provides several possible contracts for elites. Since — novas aside — nuclear weapons are the real cause of the stalemate in Kashmir, all of the involved parties want to cripple the nuclear capacities of the others. DeVries might quietly offer contracts for a team of elites to destroy the Dragon's Nest in Tibet or an airbase full of F-16s in Pakistan. Elites hired by intelligence agencies might investigate how India developed nuclear weapons in the first place.

Elite Exploitation

Elites, like lawyers, only make money if there's conflict. Kashmir, aside from being the most dangerous place on Earth, has also been the most lucrative for nova mercenaries. Perhaps elites, or the agencies that represent them, have a financial interest in ensuring that the tensions in Kashmir erupt into full-blown battles every few years, preferably around Christmas time. What about merchandisers who sell toys, T-shirts and video games based on elite reputations? They also have a stake in preventing world peace. Perhaps this is just a wild conspiracy theory that can only gain momentum on OpNet; then again, it would be awfully easy for an elite to instigate a terrorist action to keep the heat turned up....

Yes, it's paranoid conspiracy, but isn't that why we play **Aberrant**? This element might work best in long-running elite series; the characters take a few contracts, stir up trouble in a few hotspots and eventually become more trusted by their agency. Then they learn that their employers are maintaining instability around the globe. Perhaps they're even asked to cause trouble themselves. Any elite series that operates above the *Delta Force* level must eventually suggest some moral dilemmas; this is a good one.

Even if it isn't true, the "Elite Exploitation" conspiracy can also add variety to an elite game. No, of course DeVries doesn't keep the tension alive in Kashmir — the countries involved do that well enough on

their own. DeVries is innocent, but the Directive doesn't think so. Maybe the intelligence agency is paranoid, or maybe they're putting together a frame-up to benefit a rival interest. Regardless, this gives the characters a chance to do something besides execute elite contracts, and it gives the Storyteller a chance to develop the agency her players' characters work for.

Instability in Pakistan

In the Kashmiri conflict in 2006, Islamabad was leveled, and the rest of Pakistan suffered as elites slugged out the question of Kashmir's rightful ownership. Even at the end of the 20th century, certain regions of Pakistan were more or less autonomous bandit provinces ruled by local sheiks with little fealty to the recognized government.

After the devastation of 2006, however, things are positively *Mad Max*. While Premier Rashid Qureshi retains control near Islamabad, large portions of the country are indifferent to his policies, and some are downright rebellious. Inconveniently, some of these regions hosted airbases with F-16s and their nuclear payloads. Qureshi has a hard enough time controlling the militants within Kashmir. Lacking an absolute central authority, the risk of some element of the fractured Pakistan causing trouble in Kashmir increases exponentially. If one of these bandit provinces won control of Kashmir, after all, it might take up enough space on a map to justify international recognition.

Think post-apocalyptic war zone, **Aberrant** style. When your series' elites are feeling a little too wealthy or have a few too many endorsements, send them off to this godforsaken land (or, better yet, have their plane crash there on the way to another assignment). The Pakistan of 2011 gives Storytellers a chance to highlight the fact that war is hell and gives elites a chance to witness the consequences of their activities.

Play up the anarchy of the Pakistani bandit provinces. No doubt, such a disorganized place needs strong leadership; the warring provinces might flock to an elite's banner (whether the elite wants them to or not). DeVries might take a contract from Qureshi for a group of elites to come in and support his regime as he tries to reunite the country. Various intelligence agencies might want to know which bandit kings control airbases with F-16s. Regardless, Pakistan is a lawless place, and even the weakest nova could change the course of the entire country.

Militants in the Hills

Aside from the three governments and one international organization interested in Kashmir, those people who live in the occupied territory itself also have an interest in the destiny of their homeland. Small sects of Muslim soldiers constantly harass the DMZ forces by sabotaging military installations and raiding villages perceived as too sympathetic to the UN invaders. The Hurriyat Conference, the largest such sect, seeks to oust Project Utopia and the UN and establish a Kashmiri government with close ties to other Islamic nations,



particularly Pakistan. Another guerilla group, the Jammu and Kashmir Liberation Front, seeks an independent government for the region with no such close relationship; the people of Kashmir have been tossed around between India and Pakistan too long, and the land will never know peace until it can speak for itself. But as long as Karachi remains out of the hands of Kashmiri militants, no move for independence can succeed.

The fanatical insurgency in Kashmir might lead to numerous contracts for elites. Still, short of genocide, ridding Kashmir of militants is impossible. Any elite contracted to fight them must deal with this frustration, the pleas of a people that have no voice in a conflict they're at the heart of and the Project Utopia peacekeepers as well.

The Shingo Aviary

The DMZ is actually something of a misnomer. While there are dozens of military facilities all along the DMZ, the missile base dubbed the "Shingo Aviary" deserves special mention because it's actually within the DMZ itself. The Pakistani government has two well-paid elites maintaining the facility 5,000 meters above sea level in the mountains overlooking the Shingo River. Their quantum constitutions allow them to function in the extreme cold and thin atmosphere. Although the missiles housed there are probably not of the atomic variety, they can presumably strike targets all over India. Needless to say, India is furious that Project Utopia allows the existence of such an installation within its DMZ, but the UN generals who oversee the region believe that the Shingo Aviary is comforting to Pakistan, a country outmatched militarily by India. That comfort, they think, reduces the number of terrorist acts Pakistan is likely to undertake. Still, the Shingo Aviary serves as another point of contention in the argument over Kashmir and gives Pakistan its only credible military asset aside from its elite budget and warm relationship with DeVries.

Recently, India has violated the DMZ no-fly zone by sending a Russian MiG and two French Mirages to photograph the installation. In addition, Column Shiva is secretly assembling a strike team of elites dubbed "the Naga Regiment" to eliminate the two Pakistani novas and destroy the base. On the day they're successful, UN peacekeepers in the region will probably require an extra provision of sun block.

Elites might be hired to join (or stop) the Naga Regiment. Also, the Shingo Aviary could become the nova Alamo — the players' elites easily take control of the installation, but then they have to hold it against India, Pakistan, Project Utopia and probably China too.

Northern Light Infantry

Captain Sayed Salahuddin lead Pakistan's Northern Light Infantry into Kashmir during the conflict of 2006, and the unit hasn't come out since. Nestled somewhere in the hills along the Shingo River in the shadow of the Aviary, the Northern Light Infantry, no doubt inspired by its mad leader (Salahuddin is represented in the press as Kashmir's answer to Colonel Kurtz), has aided Islamic

militants in the DMZ for two years now. Since it's better equipped than any of the militant factions within Kashmir, it occasionally lends its services to the more ambitious guerilla raids in the region. Recently, however, DMZ peacekeepers have been more effective in keeping munitions smugglers out of Kashmir.

With its ammunition running short and more of its vehicles in need of unavailable replacement parts, Salahuddin's Northern Light Infantry has become increasingly desperate in its attacks on UN military installations. Worse, members of the Chitral Scouts (a Pakistani reconnaissance unit) and the Pakistani Secret Service have abandoned their posts and entered Kashmir illegally to join the NLI.

Analysts within Project Utopia worry that the influx of Pakistani Secret Service agents, with their under-the-table connections, might provide the NLI the funds to hire elites. These same analysts vehemently recommend that Utopia hire elites of its own to handle the nasty business of assassinating Salahuddin.

Numerous possibilities for elite contracts exist here: assassinate Salahuddin, resupply the Northern Light Infantry, escort them out of Kashmir. Salahuddin might also make a colorful Storyteller character to complicate other contracts in Kashmir. And if the rumors of the friendship between Salahuddin and DeVries' General Carrington are true, the Northern Light Infantry may play a role if Carrington makes his break from DeVries National Tactical Solutions.

Mahmud the Ghaznavid

Worshiped as a being that's somewhere between a hero and a god in the cosmic scheme of things, the Indian nova Mahmud the Ghaznavid has begun a massive recruitment effort on the subcontinent to raise an army to reclaim Kashmir. He takes his name from the Muslim warlord who stormed Punjab and Sindh through the Khyber Pass in 997 — it's a name that reeks of glorious conquest. His followers, who spend most of their time seeking more followers and training in camps all over India, seem loyal to the death to this great man who promises a return to the majestic India of the past. His message is so popular partially because of its conciliatory tone; although he advocates a violent seizure of Kashmir, he also calls for tolerance of the Islamic faith and the right of Kashmiri Muslims to have a say in the government of their homeland. Muslims in India, feeling left out in the cold by the increasingly fundamentalist-Hindu BJP, find his words appealing; even a few novas have answered his call to arms. Project Utopia and the Indian government, fearing the obvious instability such a large, independent and fanatical army implies, find his teachings much less comforting.

Elites might be hired to infiltrate Mahmud's cult in order to gather information or destroy it from within. Then again, Mahmud might hire elites, with their quantum abilities and knowledge of warfare, to serve as instructors in one of his many camps. Storytellers might use Mahmud's charismatic message to shake things up mid-series; the players' elites are sent to assassinate

Mahmud, perhaps, but they find themselves increasingly sympathetic to his cause.

Congo

Conrad was right about this place — there's no room here for a man who shuns venality. I can't imagine yr. Corresp. lasting much longer. I have yet to get the name of the man in charge, and I can smell the graves even in the Kinshasha Hilton; Hieronymus Bosch monkey-men confront me at every turn; wild-eyed revolutionaries and small children hug my feet, pawing at me, begging me to be their Kurtz. I wouldn't even leave the hotel except my agent has a raging case of Mobutu fever. He'll turn on me soon — of that, I'm certain.

— From *Flare's* "Normal Lives" column, "Duke Rollo's Heart of Darkness"

While the conflict over Kashmir is international, the fighting in the Democratic Republic of Congo is a true guerilla war. The nominal government tries to fend off numerous insurgent groups, while small bands of soldiers carve up one of Africa's largest countries. The relatively wealthy nations of India and China can amass huge, expensive militaries to influence the outcome in Kashmir, but the impoverished radicals vying for the Congo have discovered a less expensive — and some say more effective — alternative to conventional weapons: novas.

A Return to African Authenticity

In the big scheme of things, Zaire's President Kabila only had time to rename the country the Democratic Republic of Congo before he was deposed in 2001. Recent historians have portrayed him as something of a paper tiger, a loud mouth with little real power to fortify his gusto. This depiction is not entirely fair; the forces Kabila had to contend with — the forces all humanity had to contend with since the *Galatea* exploded — were overwhelming. During his fall, elite warfare was invented, the Equatorial Wars were ignited, and in the international furor that followed, Project Utopia took its first timid steps to becoming global military power.

The Origins of Elite Warfare

Mobutu, the revolutionary who ruled the Congo (then Zaire) before Kabila, was born Joseph Desiré Mobutu. After coming to power, however, he adopted the name "Mobutu Sésé Séko Kuko Ngbendu waza Banga," which means "the almighty warrior who because of his endurance and inflexible will to win goes from conquest to conquest leaving fire in his wake."

Pretentious, sure, but Mobutu lived up to the name for almost 32 years. And his ostentatious title survived him: In the early months of 2000, when the Lusaka Accord that had maintained tentative peace in the Congo

began to look shaky, a young man from the mining town of Mbuji-Mayi arose to claim the same title. Lambert Asani assembled a small Tutsi militia right under Kabila's nose (Mbuji-Mayi was a key diamond-mining center that financed Kabila's withering government).

Asani's ironically named "Belgian National Congress" (BNC) began small: the assassination of a few local politicians, a few pipe bombs in barracks and the destruction of critical roads that prevented Mbuji-Mayi's diamond harvest from being shipped out of the city. By early 2001, the BNC had graduated to the status of a major political power in the region. The BNC, headquartered in Bukavu on Lake Kivu — the former European resort and tea plantation that became a war-torn mass grave during Kabila's rise to power, seized the capital of Kinshasha. Kabila remained in power in name only until April 2001, when he announced his retirement from his new home in Madrid.

Lambert Asani, son of diamond magnate Mente Asani, was certainly rich, but not rich enough to raise an army. Moreover, he lacked the influence to acquire the sophisticated military equipment that a successful coup required. Asani, who had recently erupted and had heard of similar eruptions all over the planet, conceived a cheaper alternative to conventional warfare that could depose Kabila.

Asani, though largely unrecognized except as a footnote in a few Directive briefs, is the father of elite warfare.

In January 2001, Asani and his three brothers traveled all over the world meeting with novas whose reported abilities were of potentially strategic importance in deposing Kabila. He also began a brief affair with Anna DeVries, founder of the nascent DeVries Agency (her involvement in the Congolese revolution and the subsequent Equatorial Wars later sparked the spin-off of DVNTS).

By March 2001, Asani had assembled five other novas, and together they became "the Six Heads" of Asani's newly founded BNC (the name of which perhaps alludes to the fact that Asani eventually came to view European colonialism with the same sympathy as his father). While the BNC began a small-scale uprising within Mbuji-Mayi, cutting off trade routes to prevent the loss of more diamonds that would be far more valuable if Asani's revolution was successful, the Six Heads made the first moves in what would be one of the shortest revolutions in recent history. Kabila was overthrown by the end of March and abdicated in April.

Six Heads Lightning War

The five novas assembled by Asani were cut generous checks from Asani Diamond Corporation's "Explorations" account. As soon as the checks cleared, the novas began a rapid military campaign that culminated in Kabila's defeat. While only Asani's inner circle and a few watchful Directive agents knew what it meant, the graffiti "Six Heads Lightning War" appeared in occupied cities throughout the Congo.

The Equatorial Wars

After Kabila officially renounced his presidency in April of 2001, Asani proclaimed himself president and

smoothed over lingering hostilities by offering a full pardon to all soldiers who renounced Kabila and swore allegiance to the Asani regime. The new president appointed a Cabinet of Deputies and opened the Congo to foreign investors. While the Congo's vast mineral reserves were no longer underutilized as they had been since the days of Mobutu, other countries that Kabila had negotiated contracts with — countries like Angola, Zambia and Zimbabwe — were barred from the mines they had set up within the Congo. As a favor to Anna DeVries, he established a relationship with DeBeers in South Africa.

Asani also alienated the governments of Rwanda and Uganda. These two countries had supported other insurgent groups such as the Congolese Liberation Movement and the Congolese Rally for Democracy. Asani had splintered these groups when forming the BNC, leaving Rwanda and Uganda with little influence in the new Congolese government, an influence they expected to have when their revolutions succeeded. Asani became president with some of the most powerful countries in Africa against him.

The new government didn't handle the international tension well. After revoking mining rights to most other African countries, Asani used the initial "startup" revenue generated by his family's new mining contracts with Europe and America to arm a sizeable border guard. Knowing that there's no such thing as a defensive posture in Africa, Asani hoped that a large force at the Congo's borders would spark an arms race in sub-Saharan Africa. He was right; the governments of a dozen African nations began stockpiling for a war they were unequipped to fight.

When the inexperienced, nationalistic soldiers of places like Rwanda and Tanzania began to spill over their borders into nearby countries, certain high-strung African governments panicked. Declarations of war made international headlines for weeks; the fighting reached as far north as the Sudan and Mauritania. While nothing resembling the full-scale war in Kashmir occurred, from May to November of 2001 the "Equatorial Wars" sparked a wave of intense guerilla warfare before Team Tomorrow and the United Nations stepped in. Every year since, human rights groups have discovered 10 to 12 mass graves that were filled during these seven long months. Although the actual body count is impossible to determine, the genocide of those seven months rivaled the most pessimistic estimates of the slaughter committed by Hitler or Stalin. The stench reached as far north as the Mediterranean.

The Current Situation: Congo 2011

With UN peacekeepers and Project Utopia operatives spread all over sub-Saharan Africa, Asani's government has had to pay less attention to the military matters that plagued Mobutu and Kabila. Instead, the administration has focused on opening up the Congo to the global economy. Although the country's coal reserves have become increasingly less profitable since the invention of the hypercombustion engine, Congo's diamond exports

have become almost as profitable as South Africa's, and the country (particularly the newly incorporated Asani Mineral Industries) has made billions with its exports of platinum, tungsten, aluminum and iron.

Few of these profits have filtered down to the people, however. While Asani made genuine improvements in education and health care (mostly to avoid scrutiny from Project Utopia in Addis Ababa), most of the profits from the new mineral ventures in the region found their way into Asani Mineral Industries instead of the Congolese treasury. While the Asani family, which still controls Asani Diamond Corporation and most of Mbuji-Mayi, has become one of the wealthiest families in the world, other mineral interests in the Congo resent the tight control Asani has taken over their operations. While they're making more money than ever before, too much of their profit still rides off on Asani's hip.

Similarly, Asani's promises to avenge the Tutsis and bring democracy to Congo fell flat. Congo is still officially in a state of "wartime emergency" and has held no elections. Pleas by Tutsis to strike against the Hutus or to investigate mass graves are still ignored. Asani claims that the graves were either dug during Kabila's reign or in the confusion of the Equatorial Wars, and as such, they are not his responsibility to unearth.

Also, while Ethiopia has become Africa's breadbasket, there's still massive starvation in eastern Congo, where insurgents have become increasingly active. They try to destabilize Asani's rule by cutting off food shipments and burning fields in villages loyal to the Asani government. The regime does the same to villages loyal to the rebels.

There are also some troubling rumors about Lambert Asani himself. He hasn't made a public appearance in over two and a half years. His minister of information claims that he's avoiding assassination attempts by the interhamwe and the True Democratic Republic (see below), but there are also rumors that Lambert Asani is suffering some horrible taint that makes him unpresentable. A brief by a Directive agent planted in the presidential palace suggests that Asani is no longer in control of his Matter Creation powers, and that places where he spends a great deal of time, such as his bedroom, his office and the chamber of the Cabinet of Deputies, have been warped into increasingly disgusting places where the walls are sticky, the carpet stinks of decay and the ceiling slowly crumbles to dust.

Ways to Get in Trouble in the Congo

For Storytellers who want to add their players' characters to the unstable mix in the Congo, here are a few suggestions:

Elite Warfare

The revolution's over. The fighting isn't. Several groups have arisen that oppose the Asani government. While most of these groups are too poor to purchase

munitions and high-tech weaponry, some can afford to hire an elite or two.

- **The True Democratic Republic:** It's an ancient pattern that's been repeated in rebellions throughout history — once the revolutionary coalition comes to power, the coalition breaks up and its former members fights among themselves. Such is the case with Alima Laurent and her True Democratic Republic. After helping Kabila rise to power and serving in his Cabinet of Deputies, Laurent went into hiding after being informed by Asani's Deputy of Security that the president had ordered her assassination over remarks she made to the press about the stifled efforts to bring democracy to Congo. Her TDR is well-funded from an as-yet-undiscovered source and she regularly does business with the DeVries Agency, hiring elites to make strikes on key sites of Asani's power, especially Asani Mineral Industries' mines across the country. The TDR has no real soldiers and is, instead, a collection of statesmen, scholars and the cynical upper classes. If the TDR came to power, they say they'd finally bring democracy to the Congo. Of course, Mobutu, Kabila and Asani promised the same thing.

- **The Interhamwe:** These Rwandan Hutu militiamen destabilized eastern Congo during Kabila's rule, at first opposing his rise to power then supporting it after he turned on the Tutsis. While interhamwe means "those who work together," it's unclear who leads it or whether it has any organization at all. These displaced soldiers engage in guerilla activities all over the Congo, mostly disrupting shipments of humanitarian aid. No longer (officially) supported by the Rwandan government, they sustain themselves by preying on the small villages that dot the plains of the eastern Congo. Like a soldier that's been shot but doesn't know he's died; the interhamwe continues its assault on the revolutionary government it unsuccessfully opposed.

While the interhamwe lacks overt contacts with novas, a charismatic leader (especially a Mega-Charismatic one) could bring organization to this scattered threat. The interhamwe certainly has the numbers, the equipment and the fanaticism to depose Asani. All it lacks is the organization. In the absence of a figurehead, however, its members are left to disrupt trade routes, bomb the occasional government building and squabble among themselves.

- **The Congolese Freedom Front:** By far the most active insurgent group in the Congo, the CFF draws its soldiers from villages all over the country. While Asani underestimates them as a gang of gun-toting children, the CFF is well supplied by at least half a dozen African nations and the United States. Most of its cash goes to hiring novas, who are key to the group's strategic attacks on targets across the country. It is headquartered in Gemena, where its members engage in daily shootouts with Congolese police and border patrols. Efforts in the east have been frustrated by the interhamwe.

While it despises the DeVries Agency for its role in Asani's rise to power, the CFF has begun an independent search for elites willing to assist its cause.

Lambert Asani Sésé Séko Kuko Ngbendu waza Banga

Background: After his successful revolution, Asani claimed to be an outraged African avenging the Tutsi slaughter committed under Kabila's rule. The true story of his rise to power, however, is a bit more complex: He certainly wanted revenge, but not for a few dead Tutsis.

Lambert Asani was never the revolutionary born to the tough streets he claimed to be. He was actually the son of Mente Asani, the wealthy owner of the largest diamond mine in Mbuji-Mayi. Belgian rule had been kind to the Asani family — Mente was savvy enough to retain much of the profit from his family's mines despite the hefty taxes required under European rule.

Lambert Asani erupted in November 1999 during a brutal fistfight with his father. The fight had begun as just another argument over whether the family could still retain its wealth under African rule or if it had been better off under colonial control as Lambert's father maintained. This particular argument, however, became violent as Lambert began to experience the awful headache that usually accompanies the activation of an M-R node. His father would not shut up, despite Lambert's increasingly loud objections. Lambert flew into a rage and pounded away at his father. When the dust settled, the older Mente was almost smothered in a pile of hot slag that Lambert's anger had formed apparently *ex nihilo*.

Rashoud facility doctors in later years classified such a quantum power as "Matter Creation." Although Lambert proved unskilled with his ability during his eruption, he mastered his powers over the next year and created massive devices at a level of complexity that few novas have ever matched.

With his father comatose after their fight, Asani assumed control of the family's business. He soon learned why his father had been so vehemently fond of colonial days: Kabila was raping their fortunes. The Congolese president refused to allow the Asani Diamond Corporation to negotiate with foreign firms. ADC couldn't order foreign industrial excavating equipment, ship to foreign distributors or subcontract mining rights to the US, Europe or South Africa. In addition, Kabila imposed a mandatory payload to be shipped out monthly on government vehicles in return for a token sum. The accounts of Asani Diamond Corporation dwindled. Asani, fearing that his family would soon be no better off than the miners it employed, vowed to stop the hemorrhaging.

A successful revolution later, Asani became the President of the Congo. His victory sparked the Equatorial Wars, but his reign has certainly been prosperous. Now, however, he is rumored to suffer from a horrible taint that occupies his attention while his country collapses.



Image: Asani isn't as handsome as he used to be. While he was once a tall African man with an intimidating nova physique, he has apparently acquired some terrible deformity that precludes going out in public. The exact nature of his hideous appearance, if the rumors are true, is a closely guarded secret best left to the Storyteller.

Roleplaying Notes: Your enemies are closing in on you. Your taint disgusts them, and they fear your power. Even Alima Laurent, the most loyal nova among the Six Heads, has turned against you. The weight of power has isolated you from your brothers in the revolution; they are ill-equipped to understand your responsibilities or your recent metamorphosis. Still, part of you realizes what you are becoming — and the souls of a million dead Tutsis buried in mass graves scream that you have betrayed them.

Gear: With his wealth and power, there is virtually nothing that Asani cannot get within a matter of hours.

Nature: Rebel

Allegiance: The Democratic Republic of Congo

Attributes: Strength 5, Dexterity 3, Stamina 5, Perception 3, Intelligence 3, Wits 4, Charisma 5, Manipulation 4, Appearance 0

Abilities: Command 5 (Cabinet Discussions), Engineering 4 (Military Vehicles), Etiquette 3, Firearms 3, Intimidation 4 (Politics), Rapport 2, Stealth 3, Streetwise 3, Subterfuge 3

Backgrounds: Allies 4, Backing 5, Contacts 4, Followers 4, Influence 4, Resources 5

Quantum 5, Quantum Pool 30, Willpower 9, Taint 9

Powers: Mega-Stamina • (Adaptability), Mega-Manipulation •• (Persuader), Matter Chameleon ••, Matter Creation •••••

Mineral Interests

The mineral-rich nation of Congo was divided up by wealthy families after the colonists pulled out, but not evenly. Now that the Asani family is raking in money and taxing the profits of other interests, some mining operations have begun to hire their own novas to give them the clout (and sometimes the Mega-Manipulation) to influence the political process and earn them more profits. In the east, some mines have novas acting as glorified security guards to prevent attacks by the interhamwe. Asani certainly does nothing to protect rival interests.

Humanitarian Assistance

Starvation was once nature's way of saying "there are too many people." Now, going hungry means "your leaders are greedy." Ethiopia purports to be the agricultural savior of Africa, but lack of food was rarely the real problem; politics have caused more starvation than famine. While less lucrative than the average elite contract, humanitarian organizations spend large portions of the donations they receive to hire novas to protect food shipments from hijackings by hungry rebels or military strongmen who want to starve their populations into submission.

Seizing Power

If Asani can do it, why can't someone else? An African-born nova with considerable power, or even a mercenary foreigner who wants a country of his own, could rise up to depose one of the regimes (or the occasional legitimate government) that controls some country in Africa. The interhamwe, currently disorganized and ineffective, seem ripe for co-optation by a charismatic leader.

Of course, insurgency is a favorite pastime in post-colonial Africa, even in the shadow of Addis Ababa. Those who rise to power have difficulty holding it for long.

Other Elite Hotspots Around the World

Although Kashmir and Congo are currently the most active markets for elites, nova mercenaries are also working in other hotspots around the world. Although these engagements take place on a smaller scale, there's no reason to assume that these conflicts won't eventually blossom into protracted and profitable wars for the elite cottage industry.

Learning French the Hard Way

In early November 2006, there were two attacks on Canadian government buildings in Ottawa and Toronto. Although investigators described the attacks to the press as something like classic "anarchist mad bombings," the truth was much more troubling. The damage to the buildings superficially suggested that the assassins used explosives, but the corpses of the slain government employees were pulverized with no signs of burns. The bodies looked like they'd been squashed, not blown up.

After conferring with Project Utopia, investigators concluded that a nova with gravitokinetic powers probably carried out the attacks. Gravitational anomalies at the sites confirmed the autopsy findings. The victims in Ottawa were flung against walls by a tremendous force and splattered like bugs hitting a windshield. In Toronto, workers apparently became heavier and heavier until the weight of their flesh became so great that their skeletons collapsed. All that remained when police investigators arrived were puddles of meat and blood.

Though both attacks involved gravitokinesis, and happened a day apart, the distinct techniques used in each attack suggest that two different novas might have been responsible. The matter can't be conclusively resolved because neither building had internal surveillance equipment — an oversight the Canadian government has since corrected in all federal offices.

On November 5, 2006, a Quebec separatist group claiming to be the re-formed *Front de Liberation de Quebec* claimed responsibility for the attacks. Although dozens of terrorist groups made similar claims, only The FLQ phoned the Ottawa police with a correct description of the attacks, rather than describing the inaccurate version released to the papers. The spokesman for the separatist group warned that similar attacks would take place all over Canada until Quebec was granted status as an independent nation.

There were no more attacks, however, until September 2010, when the Canadian embassy in Turkey suffered a similar gravitokinetic assault. Coming after weeks of heightened tension over the Quebec issue, a few groups of outraged Canadians traveled to Quebec and administered angry beatings to some unlucky Quebecois.

Now the cries for independence are louder than ever, and larger portions of the country are ready to be rid of the province. With their goals closer to realization, it's likely that the FLQ's attacks will continue in the months to come. Meanwhile, more members of the Canadian Parliament are supporting a revival of the War Measures Act, a provision for martial law that was used in October, 1970 to round up suspected dissidents in Quebec.

While most Quebecois feel that their province deserves a larger role in the Canadian federal system, a sizeable minority regards Quebec as a conquered territory. Ever since French Quebec was overrun by the British, certain elements have pressed for independence. While the slim majority of the population has voted against referendums on independence in the past, the rising tensions have resulted in a larger pro-separatist faction within the government of Quebec. The premier, in particular, is pushing for another referendum on independence in 2012.

The dispute over Quebec's sovereignty, and the recent attacks in particular, give Storytellers the chance to explore the subtler side of elite activity. There are no battlegrounds, no exploding tanks, no soldiers basted in napalm. Still, the Canadian government is unlikely to ask for further assistance from Project Utopia in the investigation. Like its neighbor to the south, Canada sees Utopia as a threat to national sovereignty and is hesitant to grant it access when

it doesn't have to. The Directive, for reasons unknown, has only allocated token resources to the case.

Rather, DeVries is quietly seeking novas to fill a contract to assist the inquiry — a prime opening for an elite who's a talented investigator but lacks the prowess for military engagements. The Canadian government has requested that DeVries select elites with "discretion," since any activity by the federal government regarding Quebec is inevitably perceived as a "clamp down." Given the slim defeat of the last independence referendum, any "misperception" could add a new nation to the North American map.

Poor Man's Strategic Force

Along the Chinese coast, the People's Liberation Army has set up automated missile batteries with warheads pointed at the sea, creating what some pundits in the media are calling "a poor man's strategic force." While China can't afford to modernize its navy to compete with the forces of the United States, the string of missile batteries provides a cheap alternative. Because of the location of the batteries, US carriers, obligated by various treaties to defend Japan, South Korea and the Philippines, are forced farther out to sea, out of range of the potential Chinese barrage but also in less strategic positions.

What's remarkable about this "strategic force" is that it's totally automated and overseen by a nova of such prodigious intellectual capabilities that he can "multi-task" and operate dozens of missiles sites, while simultaneously monitoring the coast with radar, sonar and surveillance satellites. While it's the classic problem of "all your eggs in one basket," the location of the nova's headquarters remains unknown, although the Directive and several US intelligence agencies are studying the matter.

Taiwan, terrified by China's overnight strategic dominance of the East China Sea, isn't banking on novas. Despite international objections, they've thumbed their noses at the NBC weapons ban and have begun testing long-range missiles while China continues its threats to invade the bandit kingdom.

While there have been no reports of nova activity beyond the central "brain" that runs China's coastal missile batteries, if the situation in the China Seas deteriorates, it will no doubt require elite intervention; conventional warfare has suddenly become far too costly.

The Eyes of Texas Are Upon You

I wish them turkeys down in Austin would do something about all these Michael Archangel freaks. Damn fanatics. Short-dicked mother fuckers pissed all over my toilet seats.

— Johnny Delgado, proprietor of "Johnny's Stop'n'Save Gas-O-Line."

Since the death of Graham "Houston Tornado" Herron at the hands of members of the Church of Michael Archangel, nova-hating religious fanatics of every stripe have been flocking to Texas, coming down I-20 from as far east as Atlanta, settling in towns like Waskom, Kilgore, Longview and Tyler.

This is the kind of tourism that Texas doesn't want. Over the last year, there have been 20 separate incidents ranging from assaults on local law enforcement to the vandalism of a Church of the Immanent Escheaton in Jefferson. East Texas has never been a law-abiding place, but with the new zealot transplants setting up "compounds" in the area, the region now more closely resembles the chaotic times before Texas stole its land from Mexico. Needless to say, the locals resent the intrusion of the "angel freaks" peculiar lifestyle.

Despite the mayor of Shreveport, Louisiana's pleas to the governor of Texas to call out the National Guard before the situation gets out of hand, so far the governor has refused all requests for outside assistance. Quietly, however, the Texas Legislature has earmarked funds for an off-the-books project called "The Eyes of Texas." The program is in the process of hiring a few elites to deal with any potential problems that arise, such as the Church of Michael Archangel trying to make Waskom the next Waco.

Still, maybe such funding is unnecessary; given the outrage over Hill's death, Texas may witness the first time in history that elites actually *volunteer* their services.



L
I
M
I
T
E
D
E
D
I
T
I
O
N

N E L I T E S V A

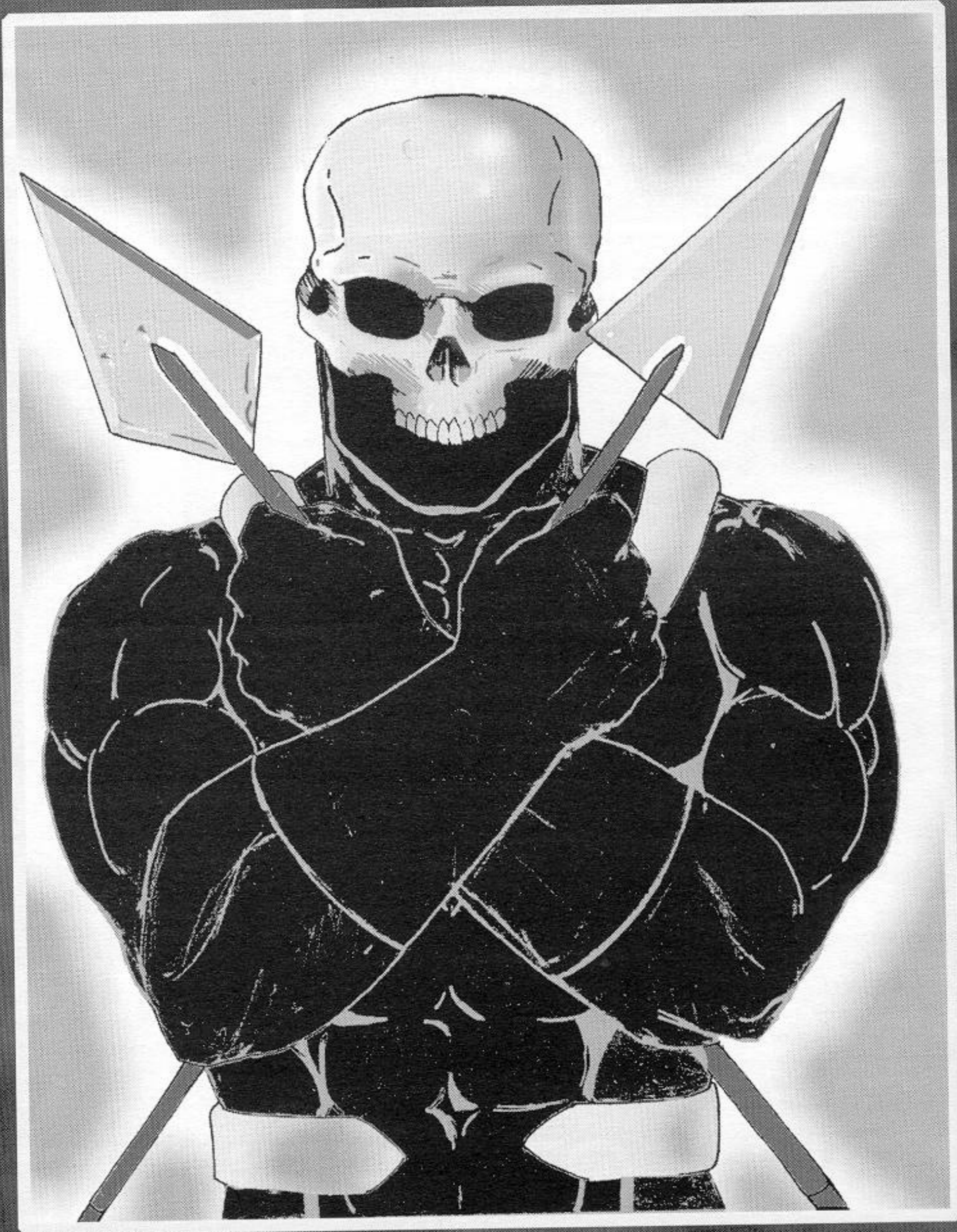

T
Ö
T
E
N
T
A
N
Z



NOVA ELITES ID CARD

NAME: TÖTENTANZ
REAL NAME: UNKNOWN
AFFILIATION: DEVRIES AGENCY

He smells your fear. He moves faster than the eye can follow. He's waiting for you to get tired. He's waiting for you to make a mistake. If you're lucky, you'll catch sight of his infamous twin spears before he uses them. If you're truly privileged, he'll let you see his golden skull mask before he takes you down.

He's out there right now. Can anyone stand against the ultimate Nova Elite?

NOVA ELITES

ARE
BROUGHT
TO YOU BY

NOVATION TOYS AND GAMES

200 FIFTH AVE
SUITE 700
NEW YORK, NY
10010



JAKE
"DRAGON"
KORELLI



"THE STONE BADGUY"
Lance Stryker



PURSUER

COLLECT THEM ALL!

CREDITS

Credits

Authors: John Cavallino, Steve Kenson, Suzannah Mandel, James Stewart

Additional Material by: Kraig Blackwelder, John Chambers and Kate Williamson

Developer: Kraig Blackwelder

Editor: John Chambers

Art Director: Rich Thomas

Artists: Steve Ellis, Jeff Holt, Jeff Rebner, Michael Spector

Cover Artist: Tom Fleming

Layout, Typesetting and Design: Brian Glass

Front & Back Cover Design: Brian Glass

Special Thanks:

Astrid "Ich bin ein Intern" Mosler for her gracious assistance in translating Totentanz's philosophy of life.

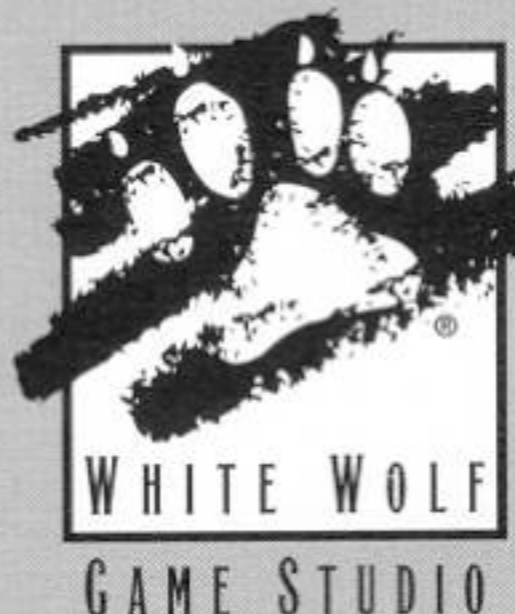

735 PARK NORTH BLVD.
SUITE 128
CLARKSTON, GA 30021
USA

© 2000 White Wolf Publishing, Inc. All rights reserved. Reproduction without the written permission of the publisher is expressly forbidden, except for the purposes of reviews, and for blank character sheets, which may be reproduced for personal use only. White Wolf, Vampire the Masquerade, Vampire the Dark Ages, Mage the Ascension, World of Darkness and Aberrant are registered trademarks of White Wolf Publishing, Inc. All rights reserved. Werewolf the Apocalypse, Wraith the Oblivion, Changeling the Dreaming, Hunter the Reckoning, Mage the Sorcerers Crusade, Wraith the Great War, Trinity, Aberrant Project Utopia, Aberrant Teragen, Aberrant Directive, Aberrant Elites and Exposé Aberrants are trademarks of White Wolf Publishing, Inc. All rights reserved. All characters, names, places and text herein are copyrighted by White Wolf Publishing, Inc.

The mention of or reference to any company or product in these pages is not a challenge to the trademark or copyright concerned.

Reader discretion is advised.

For a free White Wolf catalog call 1-800-454-WOLF.

Check out White Wolf online at

<http://www.white-wolf.com>; alt.games.whitewolf and rec.games.frp.storyteller

PRINTED IN THE USA.

TABLE OF CONTENTS

Prelude: <i>Veni, Vidi, Vici</i>	1
Chapter One: The DeVries Agency	3
Chapter Two: Other Elite Agencies	32
Chapter Three: Elite Life	48
Chapter Four: Elite Technology	67
Chapter Five: Global Hot Spots	81

SCANNED BY OTHA

in 300 dpi

For rpgbookz.dyndns.org

The best Rpgs Hub on DC++

Exclusivity

ABERRANT™

ELITES

Nova elites are paid millions of dollars to wage war for baseline clients.

Money can buy anything — governments, body counts and, some say, souls. Project Utopia calls elites thugs. The Teragen calls them toadies to their inferiors. Nevertheless, elites — high paid mercenaries, agents of the powers that be and darlings of the N! network — are more than happy to give up stability and peace for the glory of the battlefield and the comforts of blood-soaked wealth.

What would you do for money?

Aberrant: Elites reveals the lives of those novas who offer their services, ass-kicking and otherwise, for sale to the wealthy. This book exposes the shadowy DeVries Agency (and some of its even seedier competitors) and includes rules for creating your own elite agency. Learn how your character can rake in the big bucks through assassination, bodyguarding or simply ripping apart small third world countries. The best become unimaginably wealthy. The incompetent die in the mud and are forgotten. Which are you?



ABERRANT

ISBN 1-56504-692-7
WW8506
\$14.95 U.S.

www.white-wolf.com

