



HOVEL

INSTRUCTIONS



WHAT YOU NEED: Scissors. Ruler. Craft knife. Glue (PVA or white glue is best). Blunt knife and ruler for scoring. Print on 160gsm cardstock. Check your printer manual for the best material. Score all dotted lines. Short dots are valley folds. Longer dashes are mountain folds.

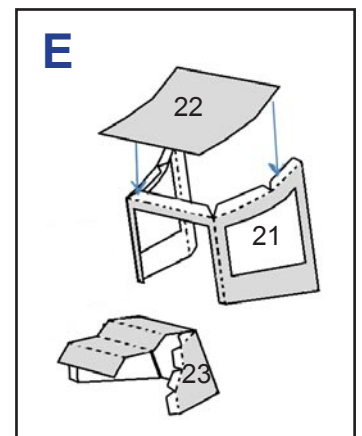
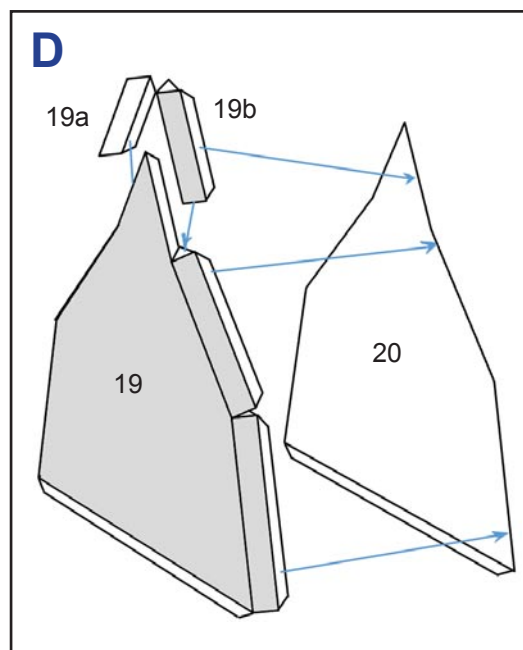
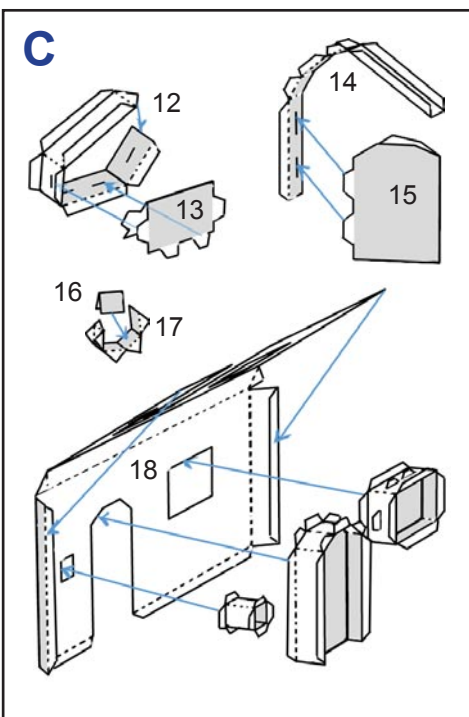
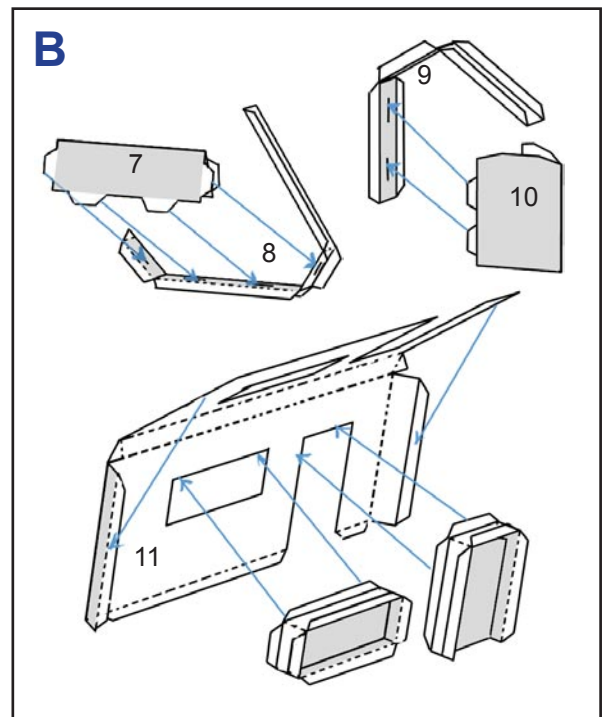
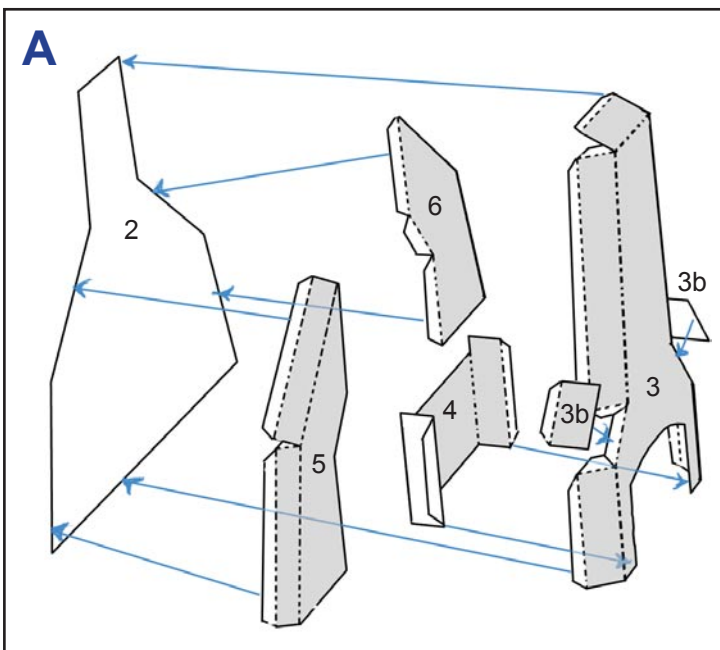

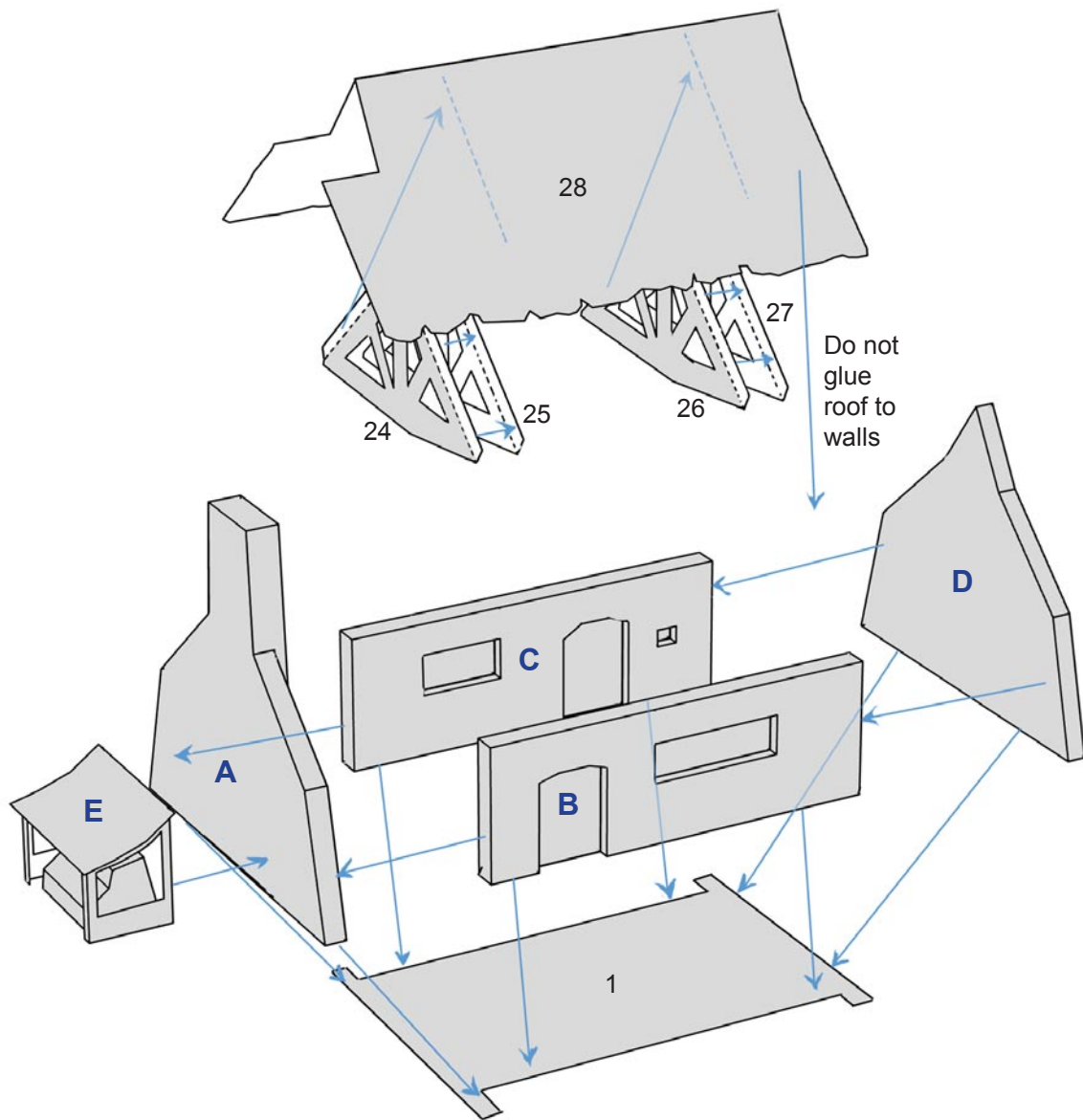

Great models at www.fantasycutouts.com



MOVEL

A card model kit
by
Leo Hartas

Please visit:

WWW
FANTASYCUTOUTS
COM

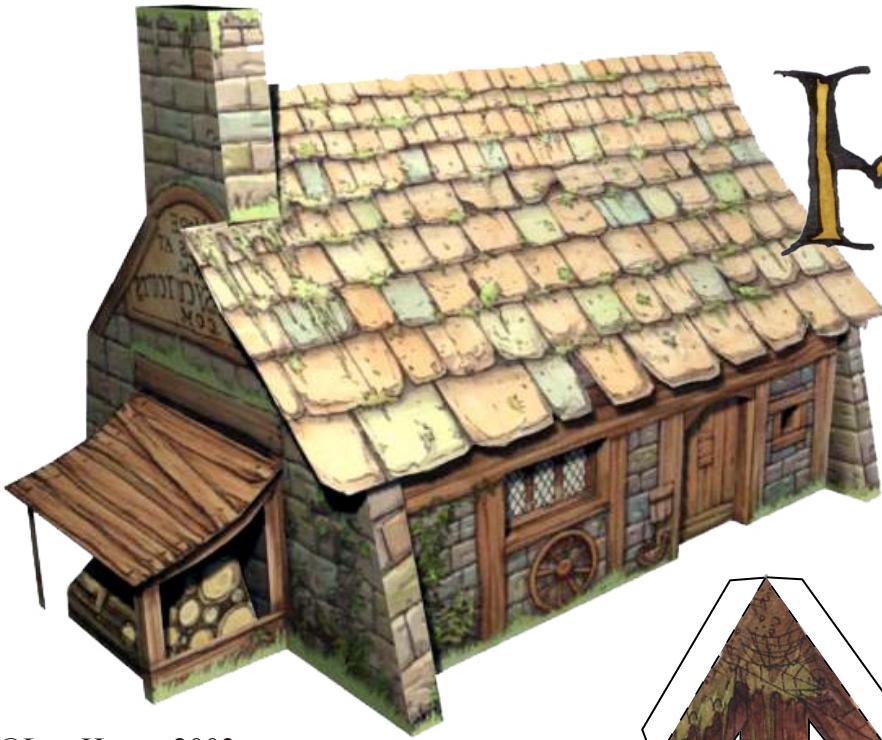

©Leo Hartas 2003
Permission granted for non-commercial use.
This product may be freely distributed. It may
NOT be sold in any form except by
express permission of Leo Hartas.
All rights reserved.

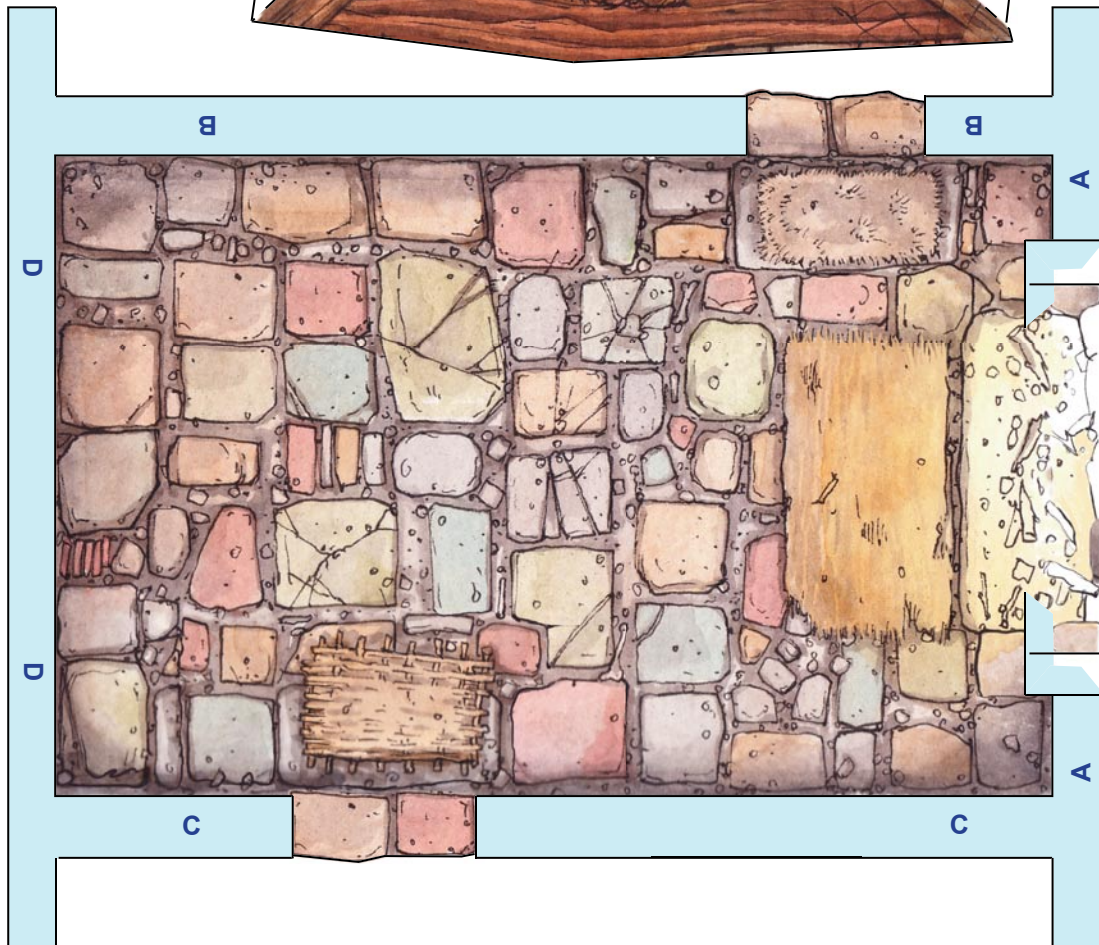
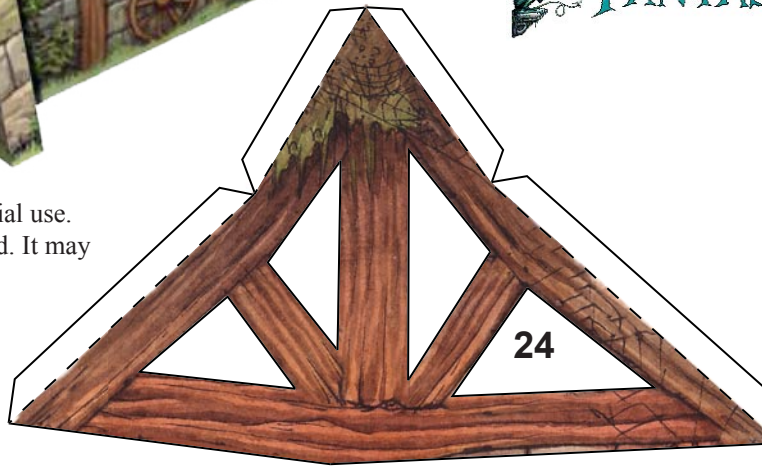



4



2

WWW
FANTASYCUTOUTS
COM
©Leo Hartas 2003

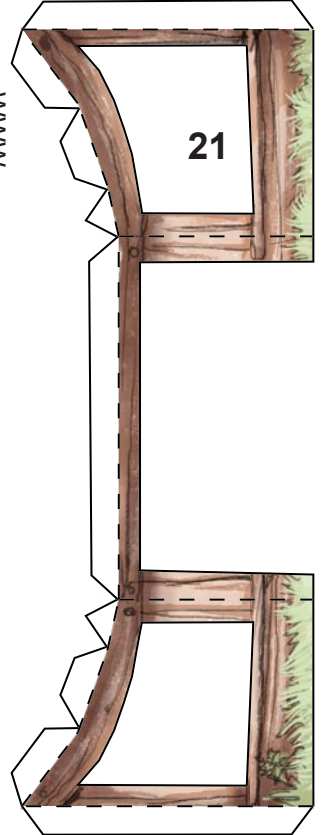

21

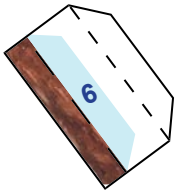

3a



3

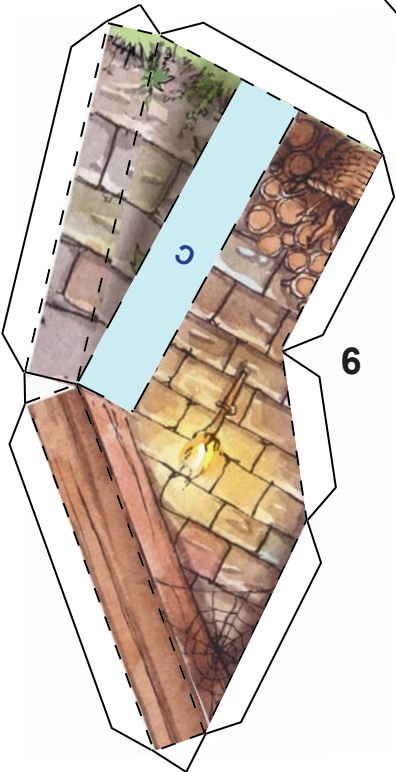

6

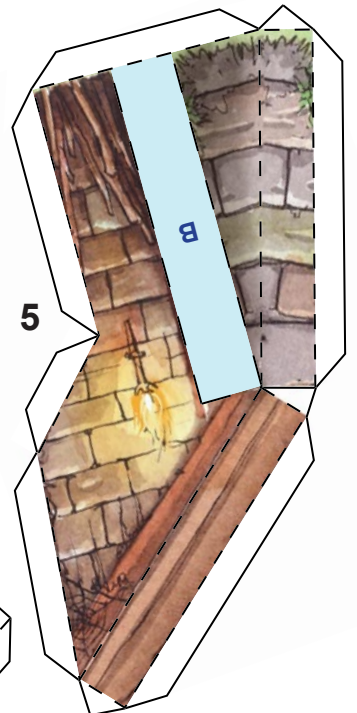
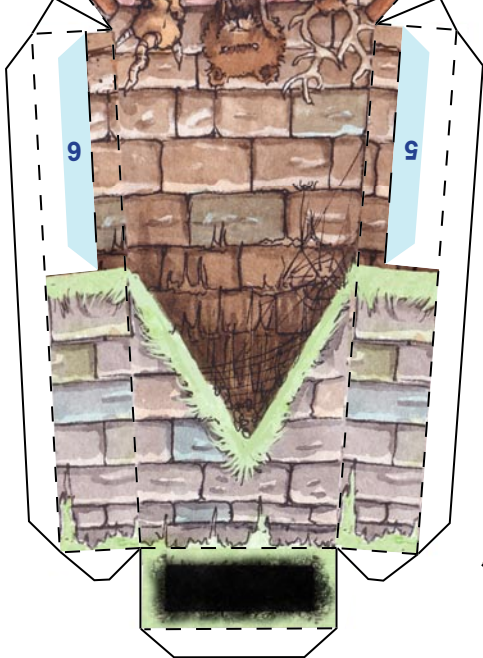

5

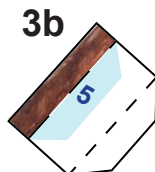

3b



19a

19b

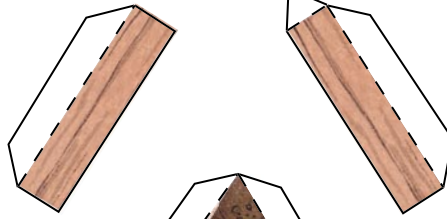

19

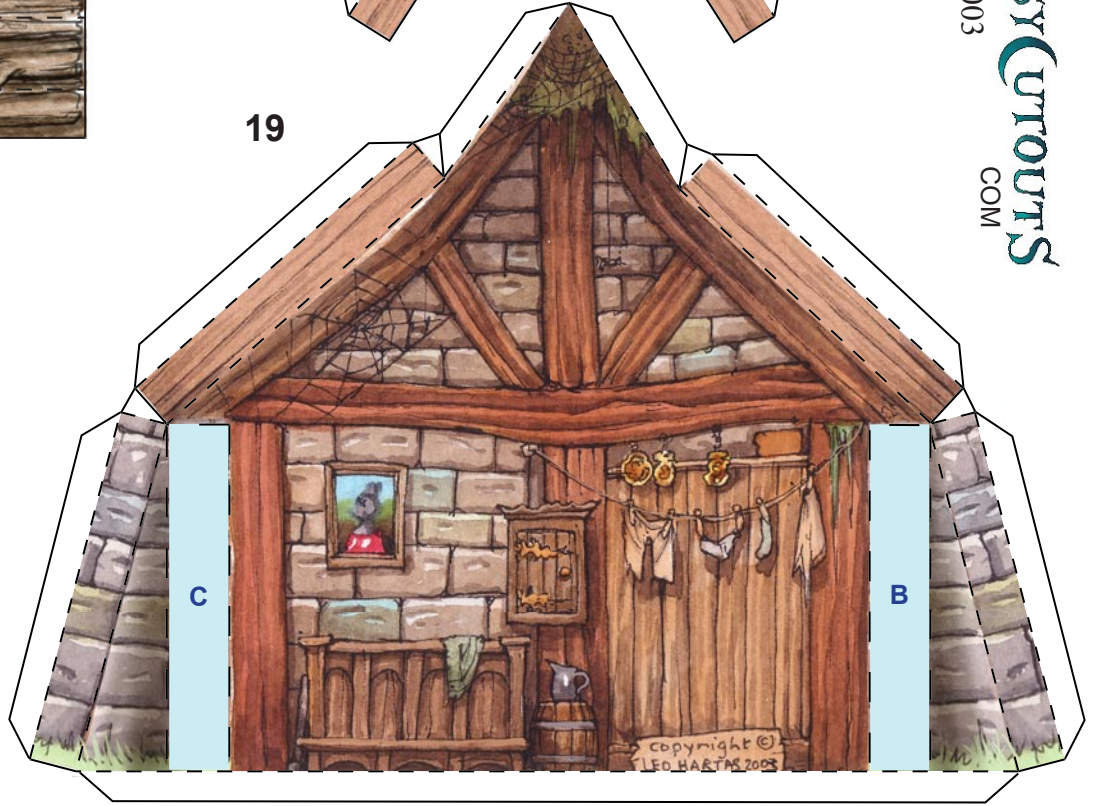

22

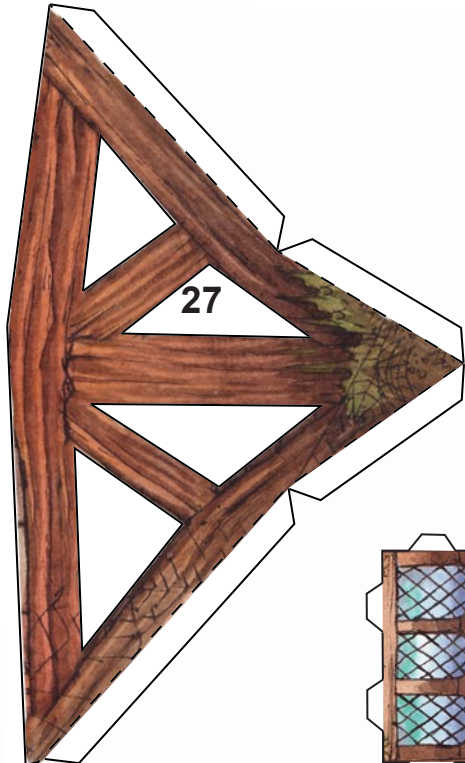

13



20

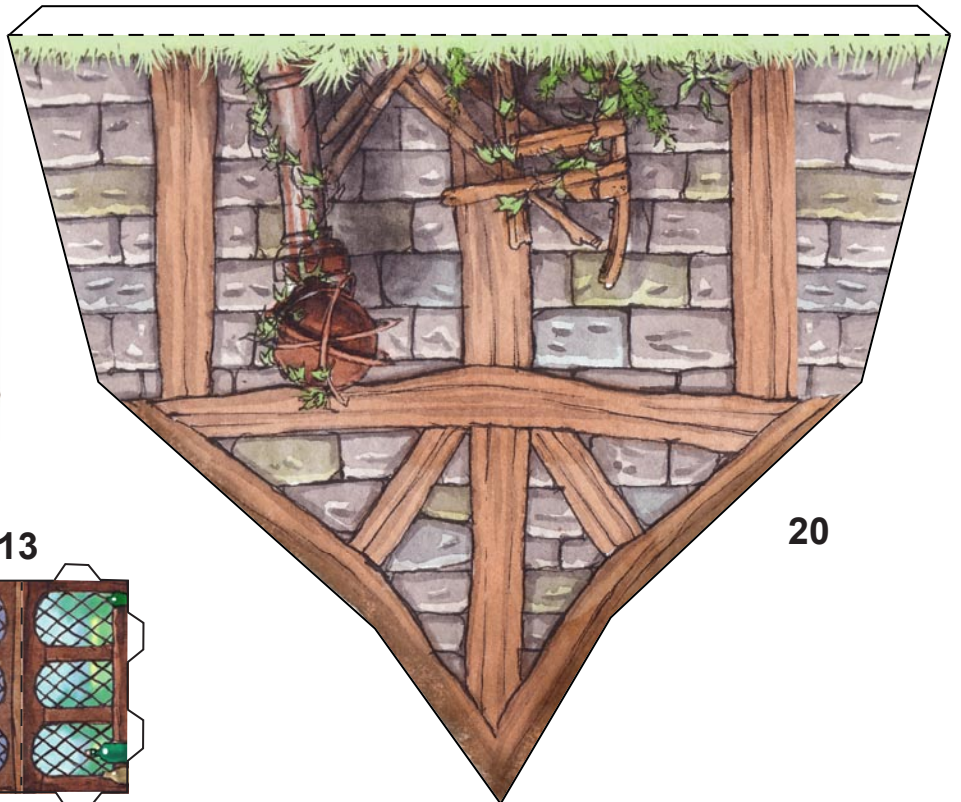

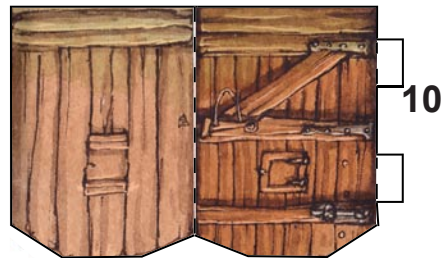
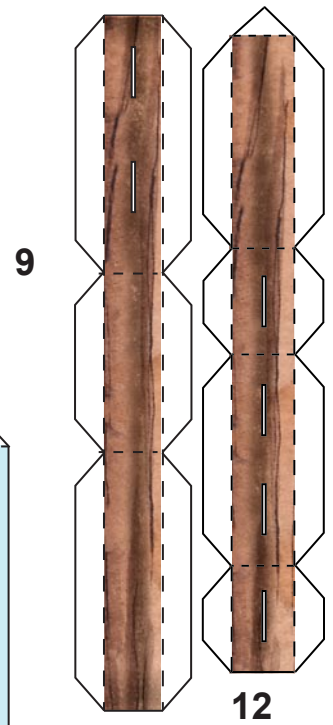
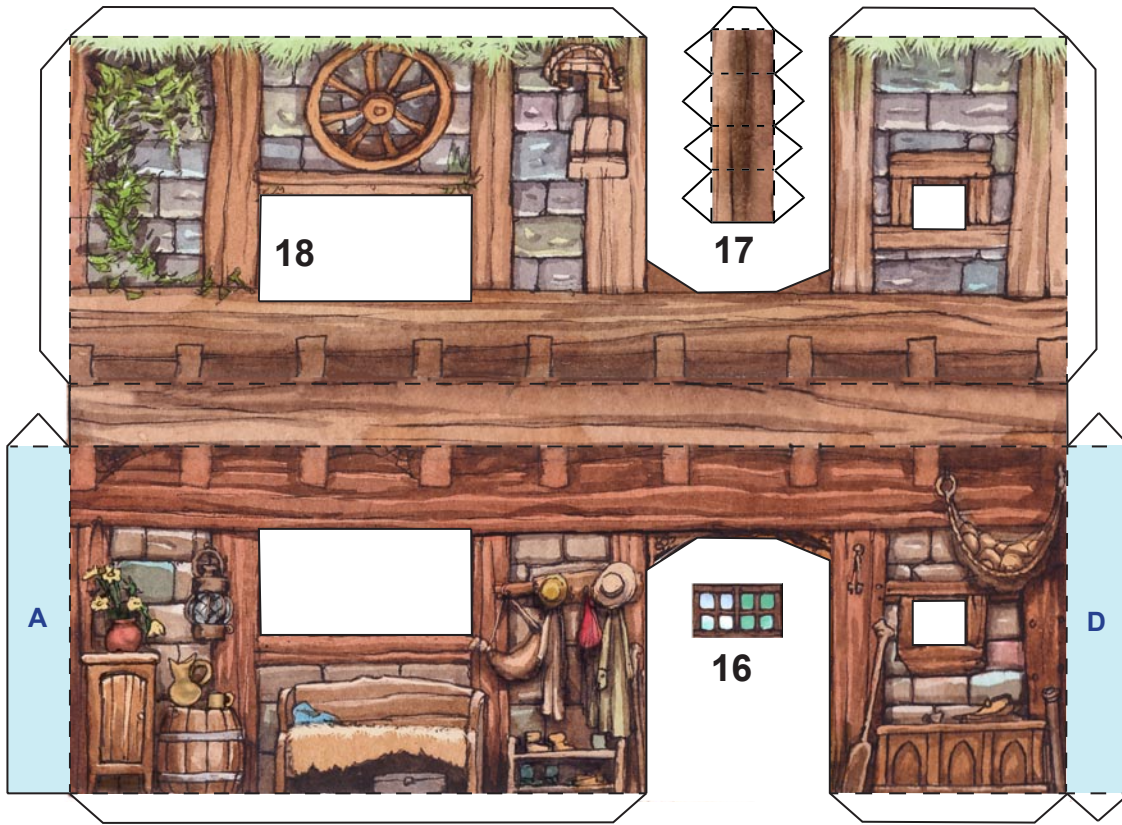

www.
FANTASY
 CROUTS
 .COM
 ©Leo Hartas 2003

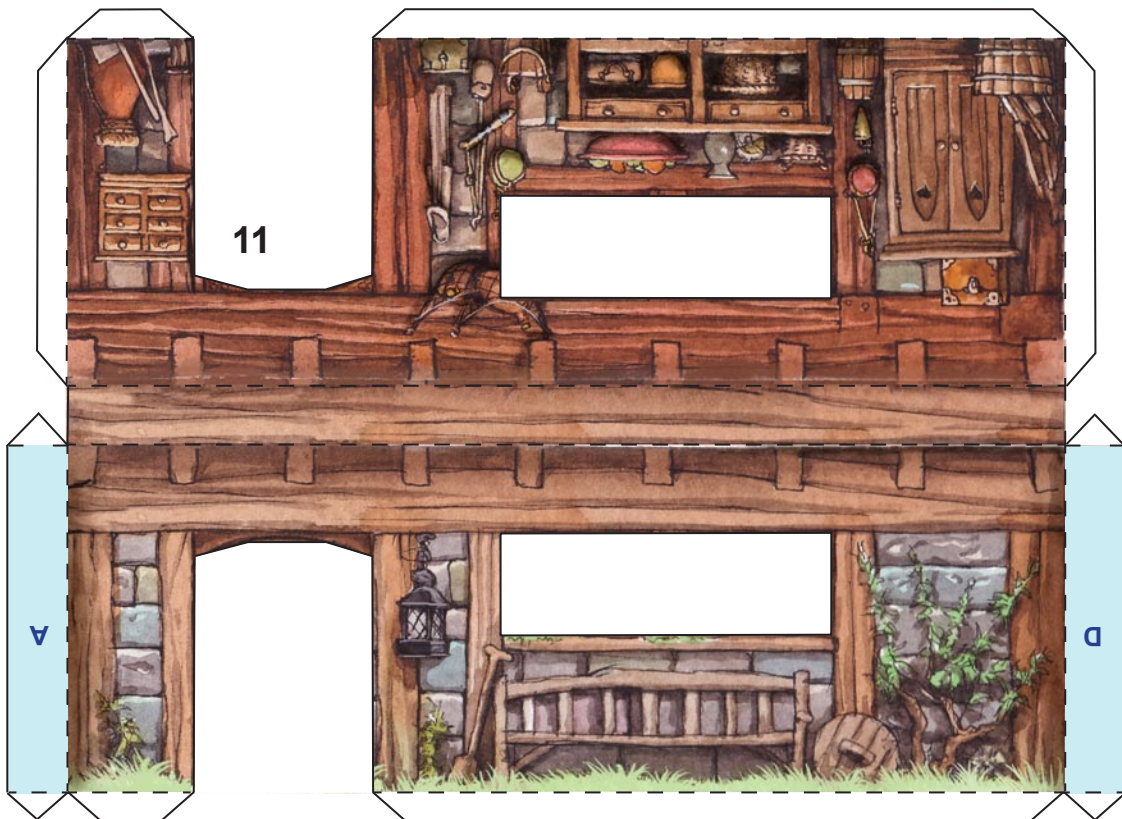
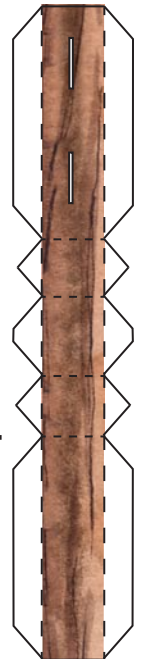

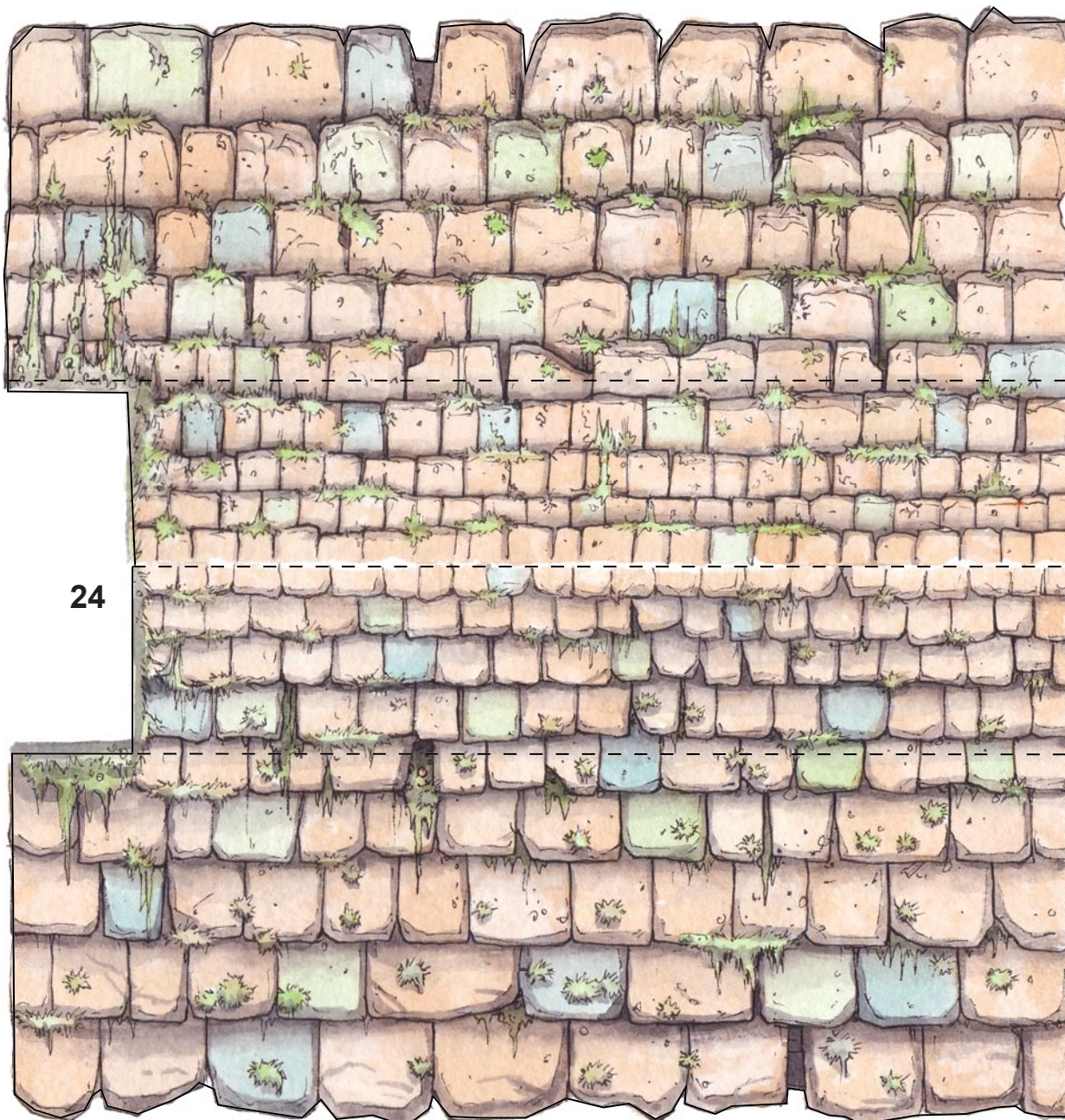

24

8

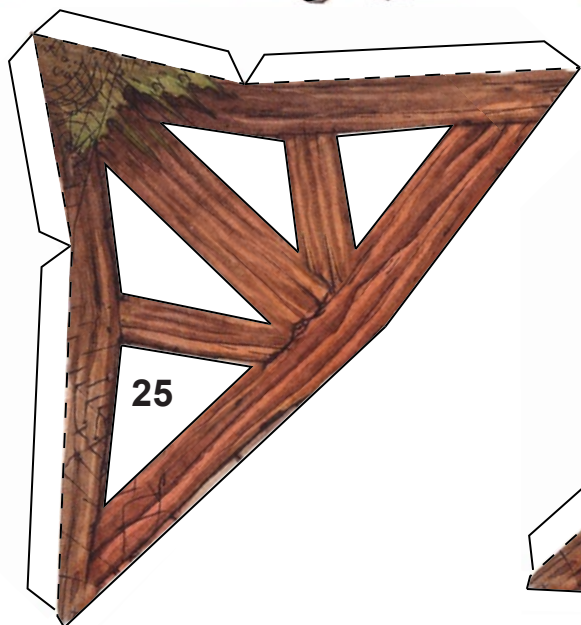

25

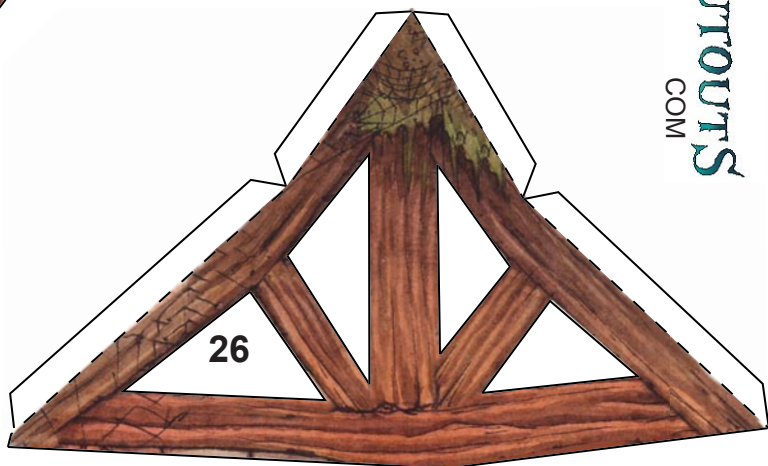

26

Avalon Games



All games available at
(Click on the name to visit their site)

RPGNow.com

e23.sjgames.com

wargamedownloads.com

wargamevault.com

Yourgamesnow.com

Drivethrustuff.com

Click here for a free
catalog and coupon
book. Inside you will
find links to all of our
great games and some
coupons for 20% or
more off selected
games.

Infinite Futures

The Future is Now

Avalon Games



S & G Battle System

Avalon's premier game system the S&G battle system allows you to play skirmish level engagements, and do so with a fast, easy to learn system that also allows for endless expansions and genres. With S&G you can fight battles between fantasy based elves and orcs, or blast off into the cold hard future with space marines and aliens.



2

Warlord Grom





2



4

Strength 3

Speed 8 / 1

Movement 4

Adrenal 4

Will 4

Health



Weapons and Armor

Weapons	As mod	Damage mod	Notes
Scimitar	-1	+1	-
Dagger	+0	-1	-

Special Abilities

- 1. Savage Blow (Attack, 3)**
Grom can make a single savage attack, often killing a foe outright with a single blow of his deadly scimitar. You must declare this ability is being used before Attack Dice are rolled. On a single attack, Grom may add +2 Attack Dice to his total for that attack. (With no limit to the number of dice that can be rolled)
- 2. Command (Move, 2)**
Grom may use his loud demanding bellows to command other orcs near by. When this ability is used, Grom may activate any one orc character, who is within five squares. This activated character may perform one action. (Note that the character may still take their normal actions when their turn comes up.) Gram may perform this ability but once a turn.
- 3. Shatter Shield (Attack, 1)**
Grom often shatters shields and weapons with his mighty blows. Declare this ability before the Attack Dice are rolled. If Grom scores a hit, instead of doing any damage, he may shatter, and thus destroy, a foe's readied weapon or shield (Your choice.) If the foe does not have a readied weapon or shield, then this ability has no effect.
Magical items gain a save. Roll 1D6, and on a roll of 6+, the item resists the effect. Per five points of the item's cost, over the first five points, adds an extra +1 to the die roll is gained.

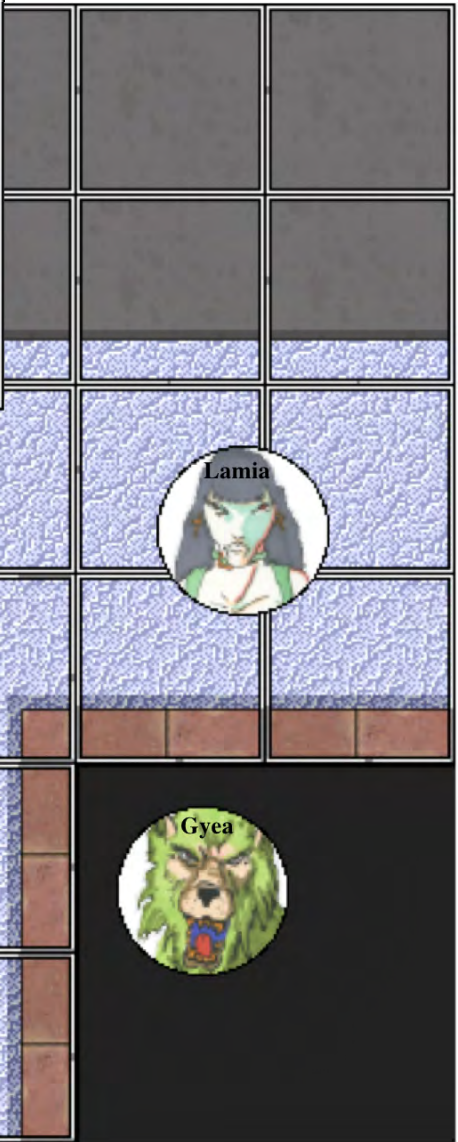

BEDROCK GAMES™

TERROR NETWORK

Counter Terrorism Role Playing Game

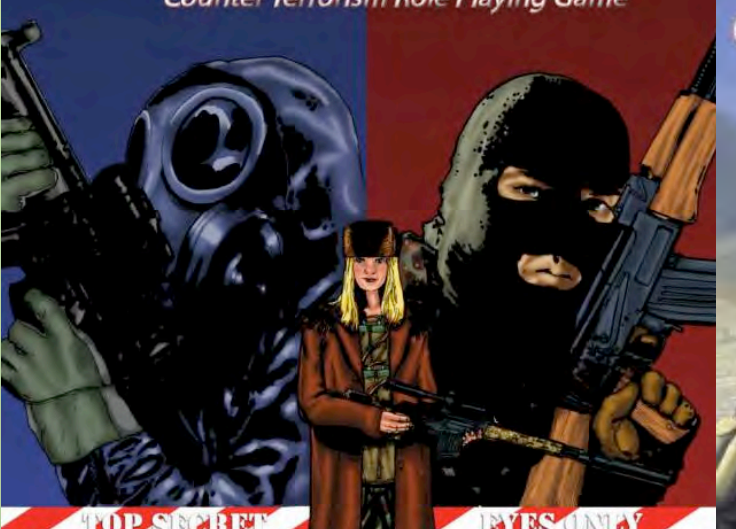

TOP SECRET EYES ONLY



Endorsed by
Sol Bradman
Director of Training, Counter Terrorism Operat
Security Solutions International

Operation Hydra Den

A Terror Network Game Module



CRIME NETWORK

The Old Country



CRIME NETWORK

Cosa Nostra

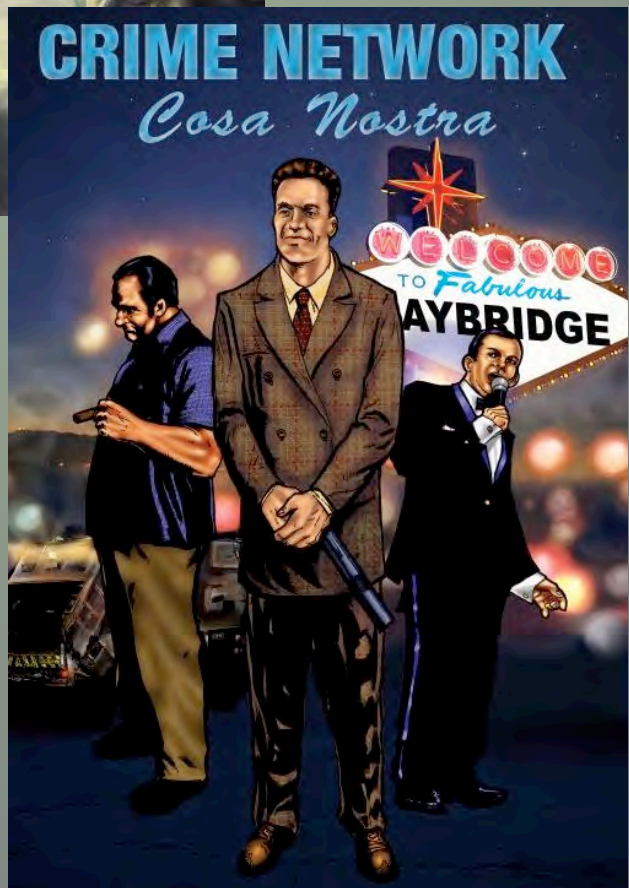

FANTASY MAKER
HANDBOOK

Frostbrand Studios
Presents

TOOSHOPPE VOLUME 11
PEEKING CANADIAN STEREOTYPES



PN

Port Nova Media

Sci-Fi Gaming at its Best

**ASTRAL EMPIRES™
NOVA COMMAND**

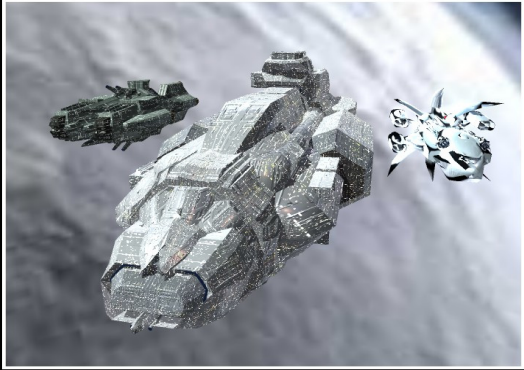

**ASTRAL EMPIRES™
STARSHIP DESIGN COMPONENTS**

FOR use with any
SCI-FI RPG SYSTEM

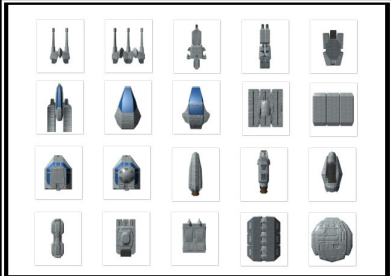

created by Kevin Monk



**SOLAR
ECLIPTIC**

AD 2100-2200



**ASTRAL EMPIRES™
NOVA COMMAND**



**ASTRAL EMPIRES™
STARSHIP DESIGN COMPONENTS**

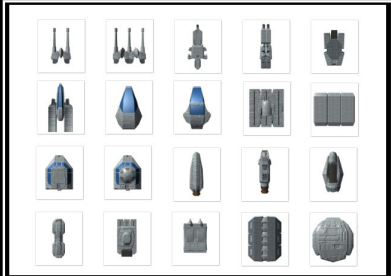

FOR use with any
SCI-FI RPG SYSTEM



Fantasy Cutouts

“Some of the best Paper Models out there.”

“Fantastic artwork, wonderfully created and well thought out as well as a beautiful addition to any fantasy RPG.”

