

Sheet: CPU

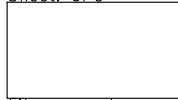

File: cpu.sch

Sheet: Video

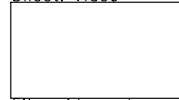

File: video.sch

Sheet: Gamepads and Interrupts



File: game-int.sch

Sheet: Power, USB, Serial

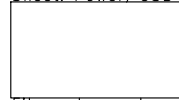

File: usbser.sch

Sheet: SD Card



File: sd-card.sch

Sheet: Keyboard, Mouse



File: ps2.sch

Sheet: OPL2 sound

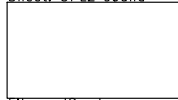

File: opl2.sch

Sheet: Real time clock

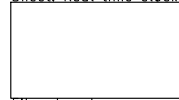

File: rtc.sch

nils.eilers@gmx.de

Sheet: /

File: main.sch

Title: kolibri

Size: A4 Date: 2021-05-26

KiCad E.D.A. kicad 5.1.10

Rev: issue three

Id: 1/9

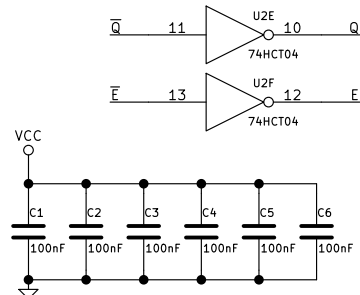
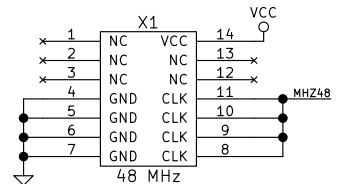
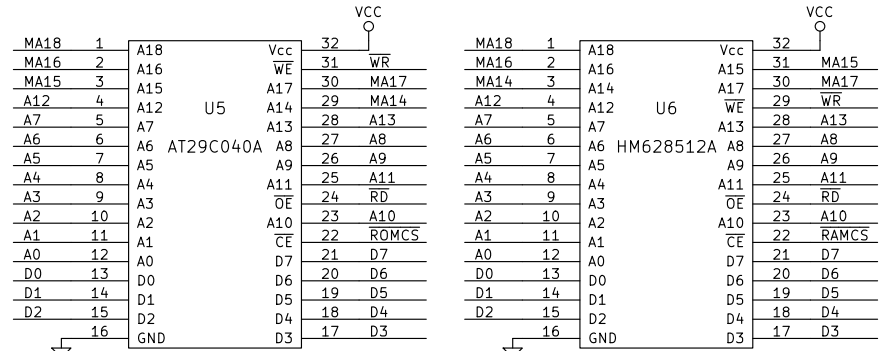
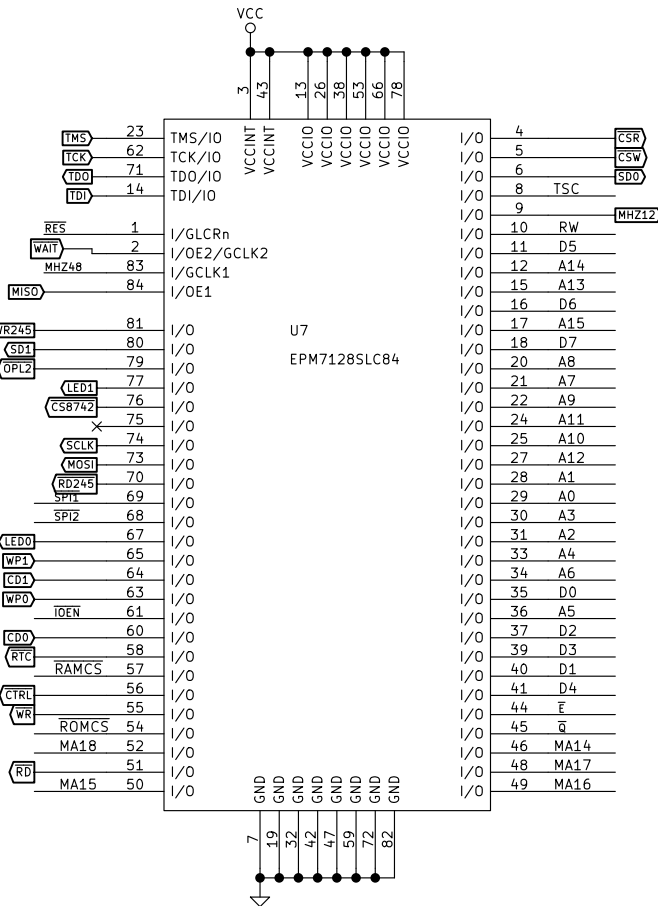
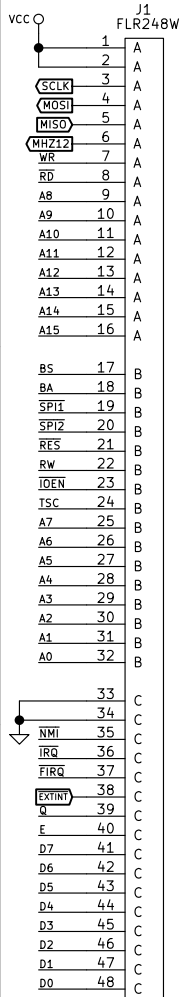
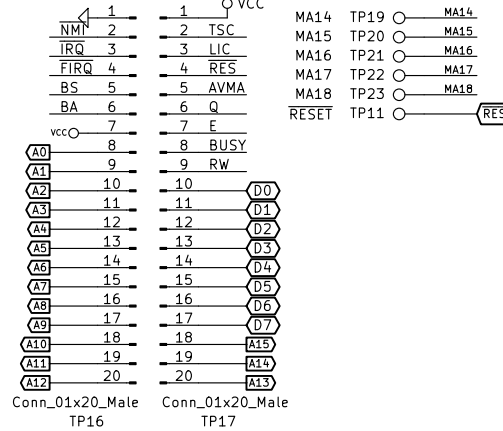
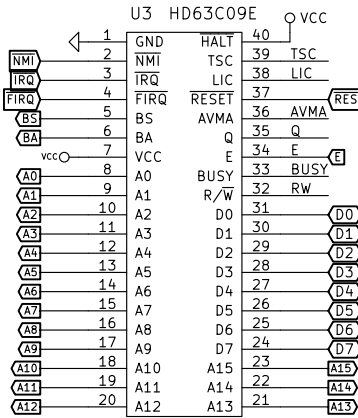
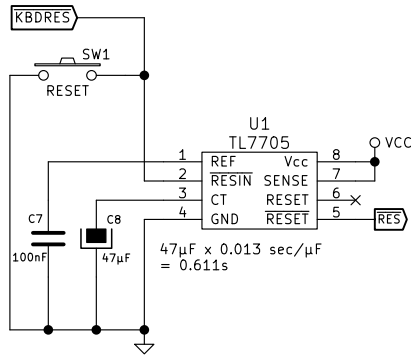

nils.eilers@gmx.de	
Sheet: /CPU/	
File: cpu.sch	
Title: kolibri	
Size: A4	Date: 2021-05-26
KiCad E.D.A. kicad 5.1.10	Rev: issue three
	Id: 2/9

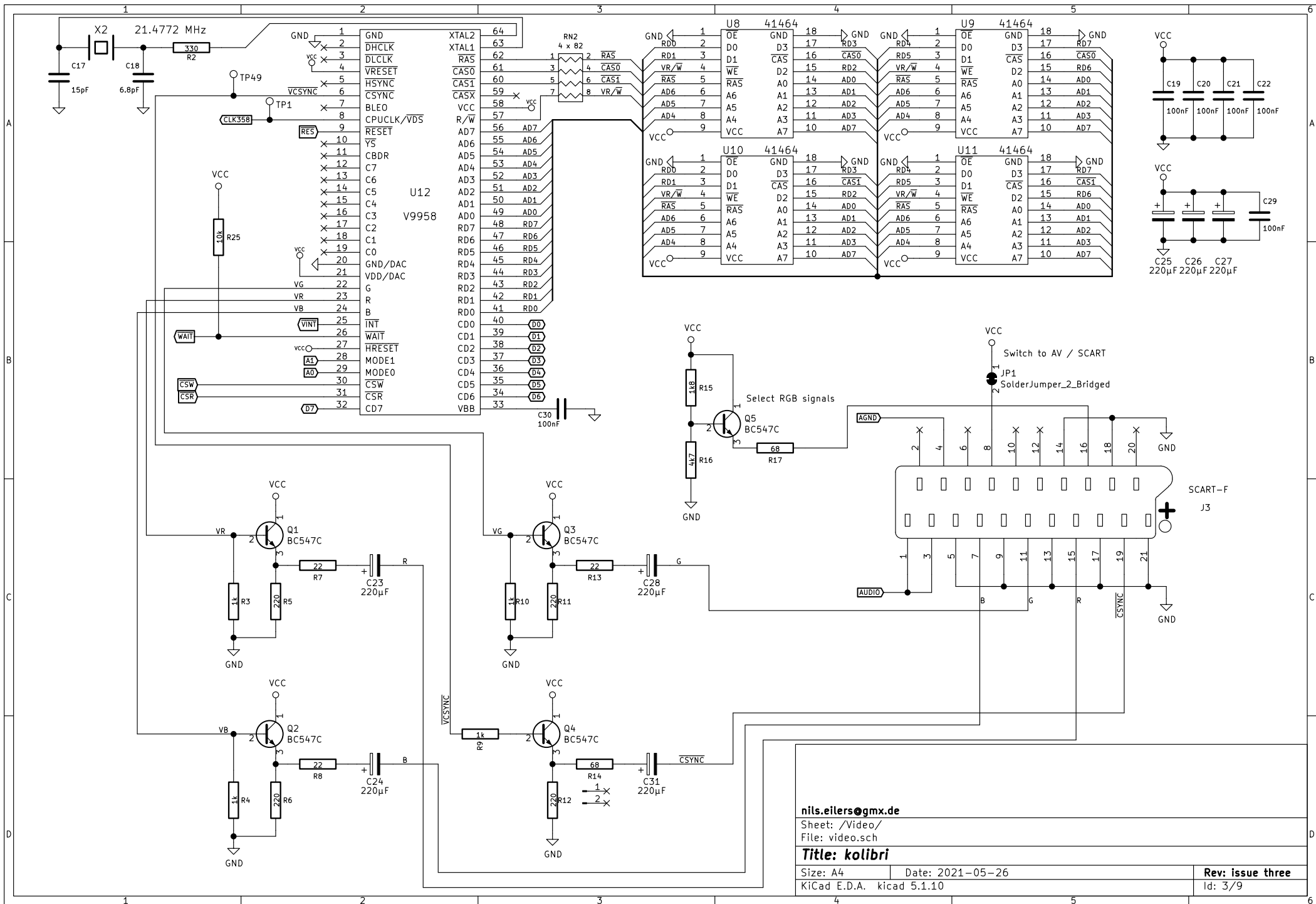

nils.eilers@gmx.de

Sheet: /Video/
File: video.sch

Title: kolibri

Size: A4 Date: 2021-05-26

KiCad E.D.A. kicad 5.1.10

Rev: issue three

Id: 3/9

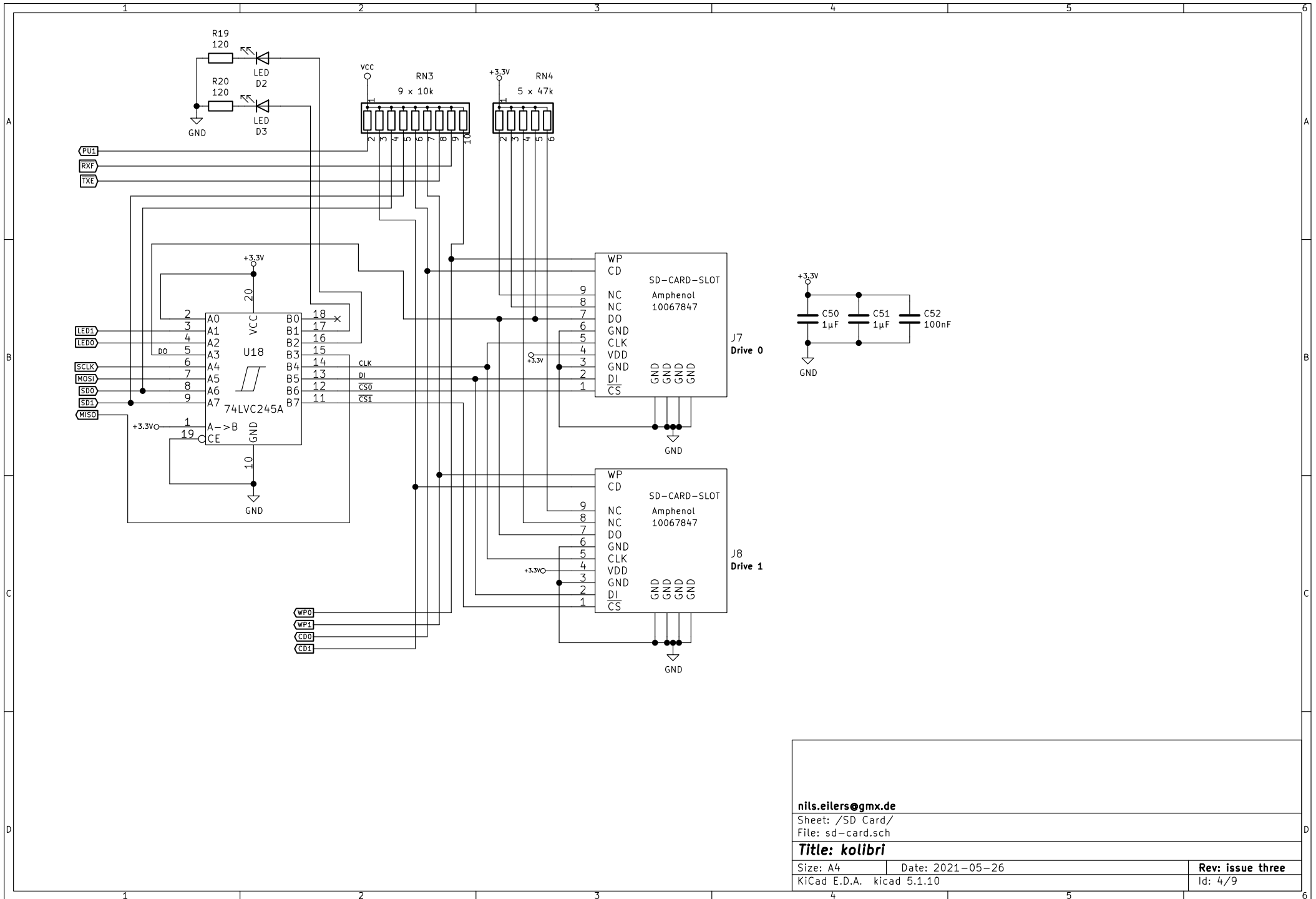

nils.eilers@gmx.de

Sheet: /SD Card/
File: sd-card.sch

Title: kolibri

Size: A4 Date: 2021-05-26

KiCad E.D.A. kicad 5.1.10

Rev: issue three

Id: 4/9

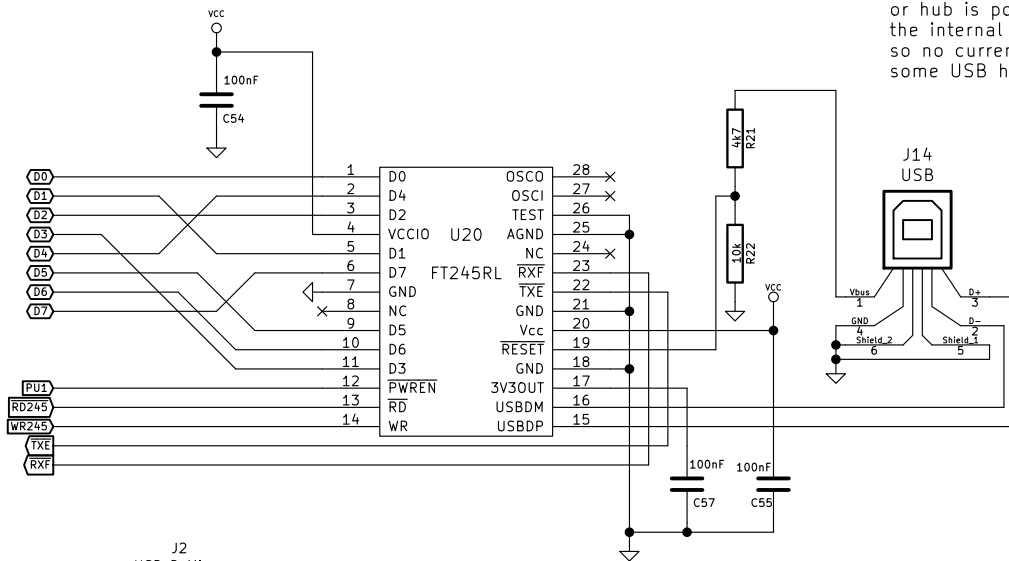

A self powered device should not force current down the USB bus when the USB host or hub controller is powered down. The USB bus power (pin 1) is used to control the $\overline{\text{RESET}}$ pin of the FT245R device. When the USB host or hub is powered up an internal 1.5k Ω resistor on USBDP is pulled up to +3.3V (generated using the 4K7 and 10k resistor network), thus identifying the device as a full speed device to the USB host or hub. When the USB host or hub is powered off, $\overline{\text{RESET}}$ will be low and the FT245R is held in reset. Since $\overline{\text{RESET}}$ is low, the internal 1.5k Ω resistor is not pulled up to any power supply (hub or host is powered down), so no current flows down USBDP via the 1.5k Ω pull-up resistor. Failure to do this may cause some USB host or hub controllers to power up erratically.

Please note that $\overline{\text{RD245}}$ is low-active whereas WR245 is high-active.

$\overline{\text{TXE}}$ = transmit buffer empty. When low, data can be written into the FIFO by strobing WR245 high, then low. During reset this signal pin is tri-state.

RXF = receive buffer filled. When high, do not read data from the FIFO. When low, there is data available in the FIFO which can be read by strobing RD245 low, then high again. During reset this signal pin is tri-state.

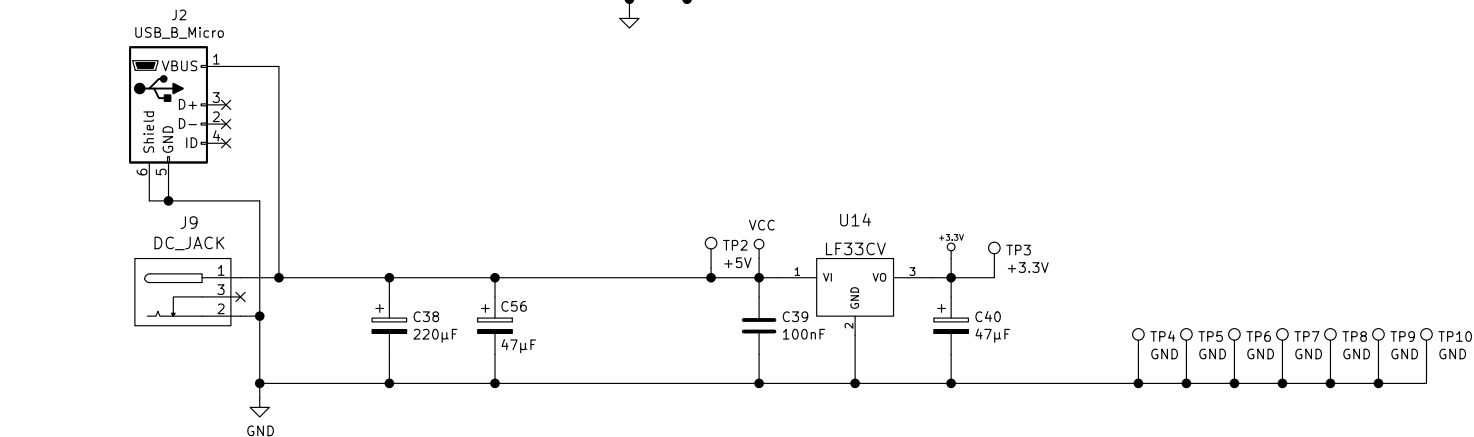

nils.eilers@gmx.de

Sheet: /Power, USB Serial/
File: usbser.sch

Title: kolibri

Size: A4 Date: 2021-05-26

KiCad E.D.A. kicad 5.1.10

Rev: issue three

Id: 5/9

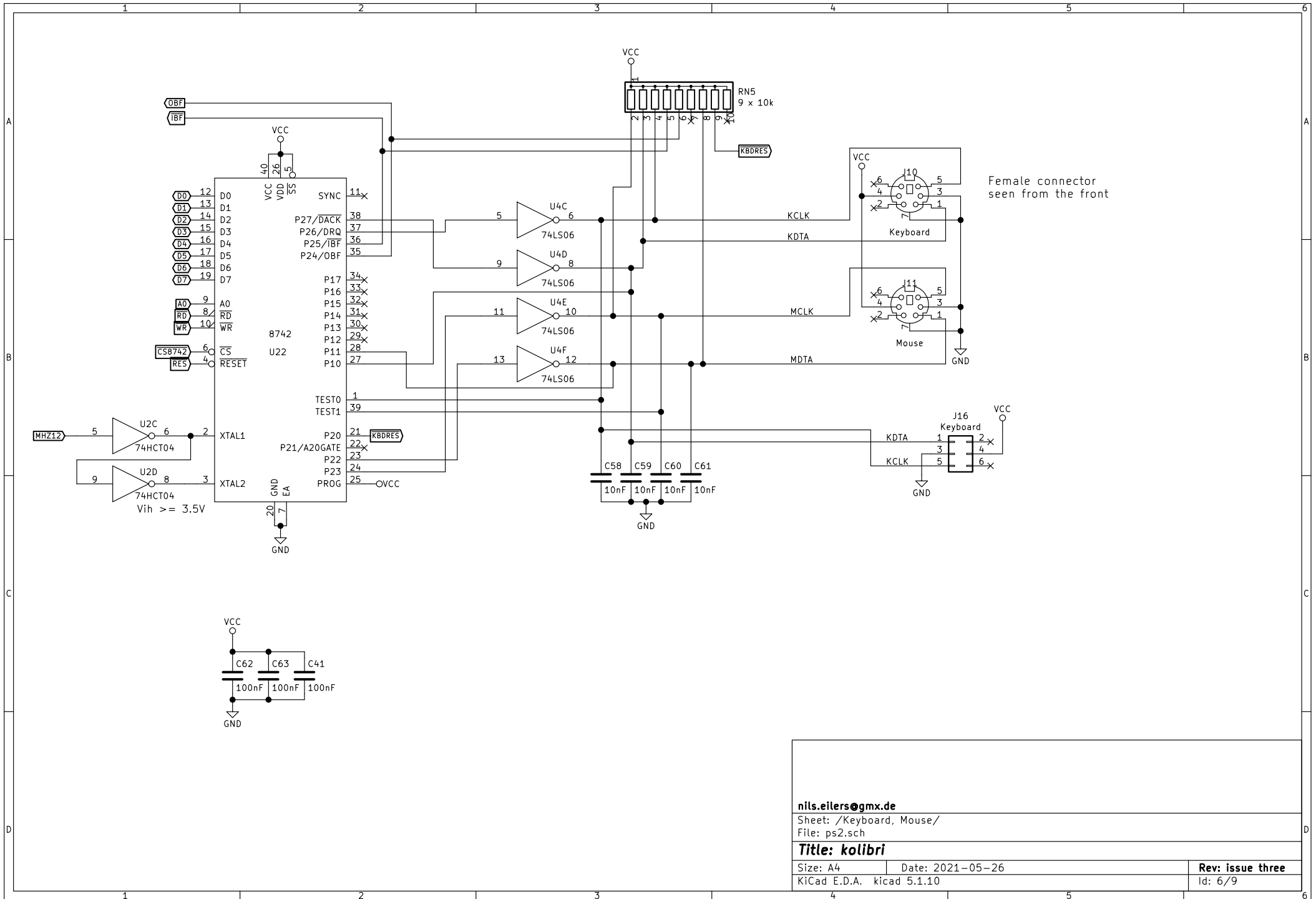

nils.eilers@gmx.de
 Sheet: /Keyboard, Mouse/
 File: ps2.sch
Title: kolibri
 Size: A4 | Date: 2021-05-26 | Rev: issue three
 KiCad E.D.A. kicad 5.1.1.0 | Id: 6/9

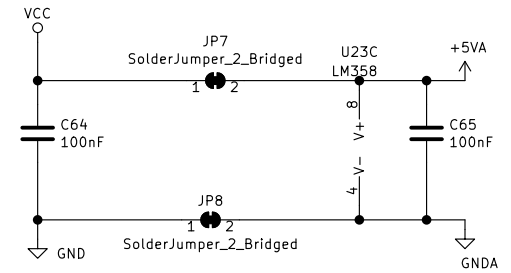
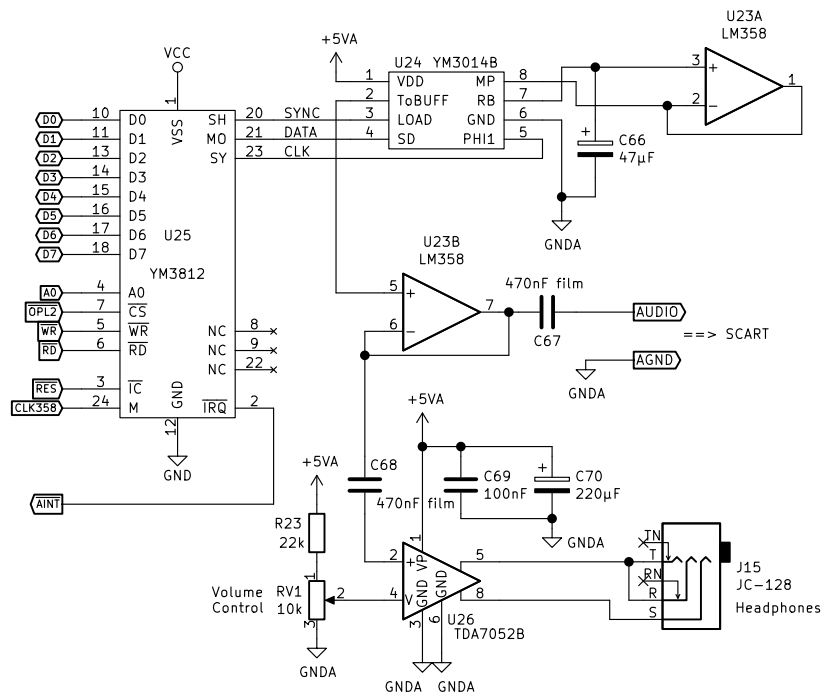

nils.eilers@gmx.de

Sheet: /OPL2 sound/
File: opl2.sch

Title: kolibri

Size: A4 Date: 2021-05-26

KiCad E.D.A. kicad 5.1.10

Rev: issue three

Id: 7/9

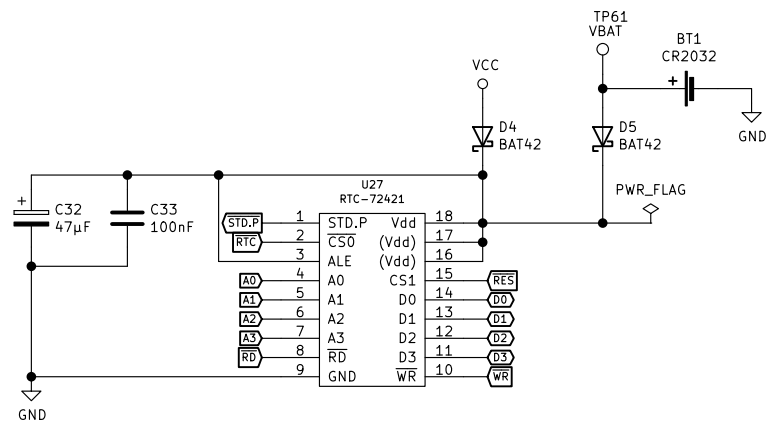

nils.eilers@gmx.de

Sheet: /Real time clock/
File: rtc.sch

Title: kolibri

Size: A4 Date: 2021-05-26

KiCad E.D.A. kicad 5.1.10

Rev: issue three

Id: 8/9

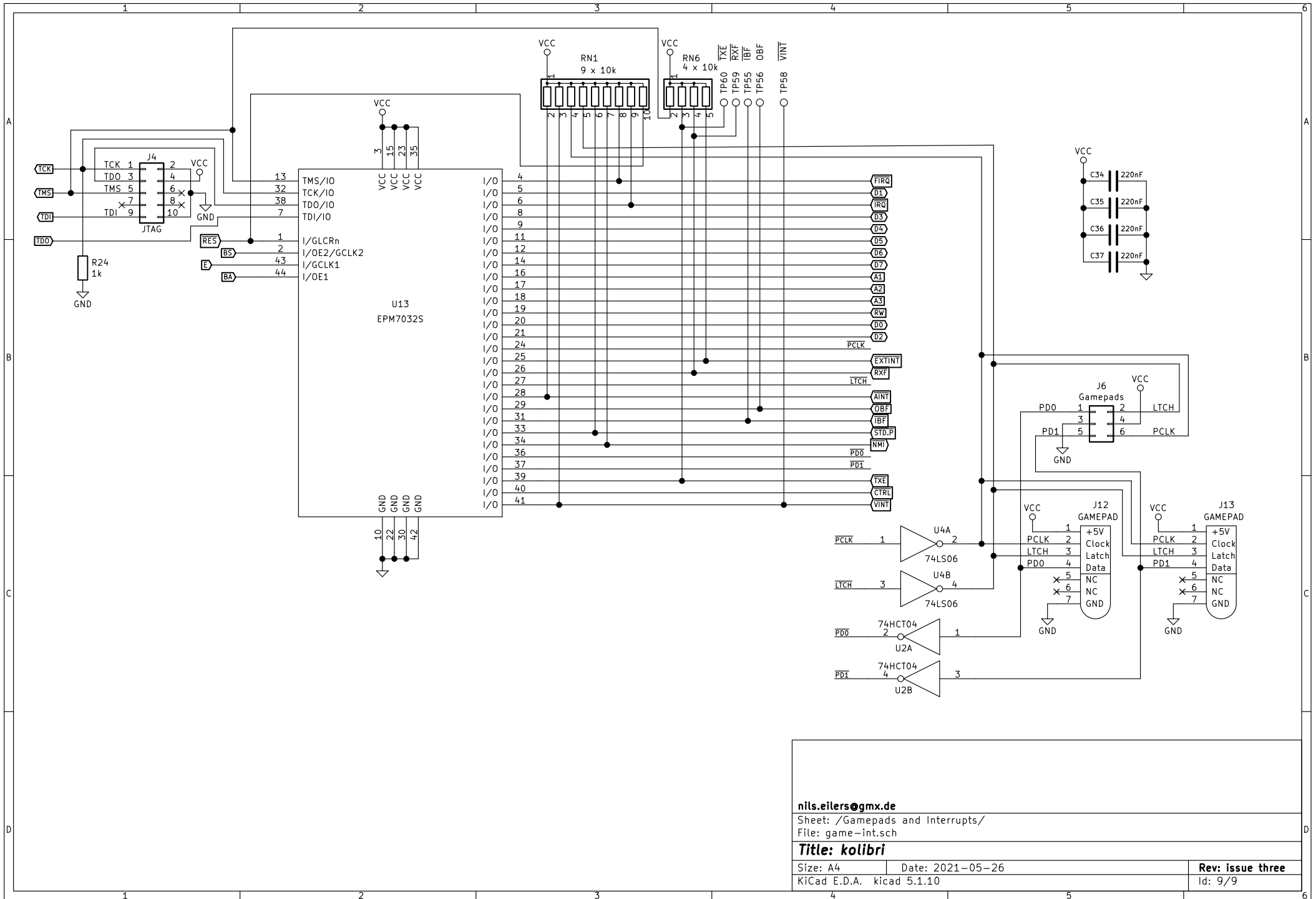

nils.eilers@gmx.de
 Sheet: /Gamepads and Interrupts/
 File: game-int.sch
Title: kolibri
 Size: A4 | Date: 2021-05-26 | Rev: issue three
 KiCad E.D.A. kicad 5.1.10 | Id: 9/9