

HD63C09E CENTRAL PROCESSING UNIT

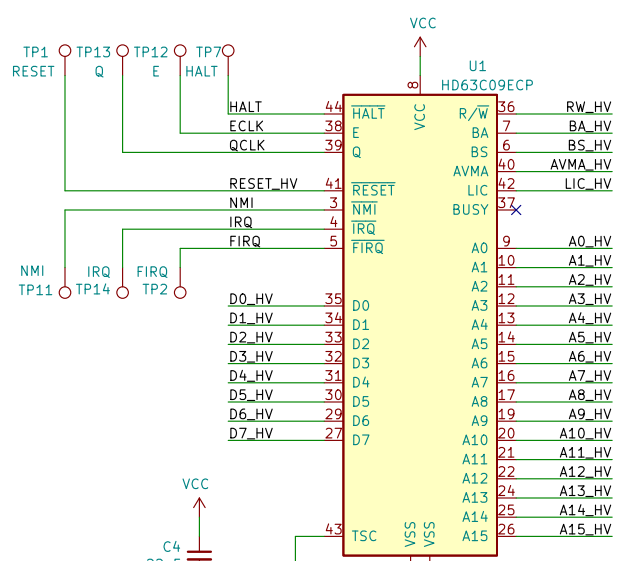

BUS LEVEL TRANSLATORS

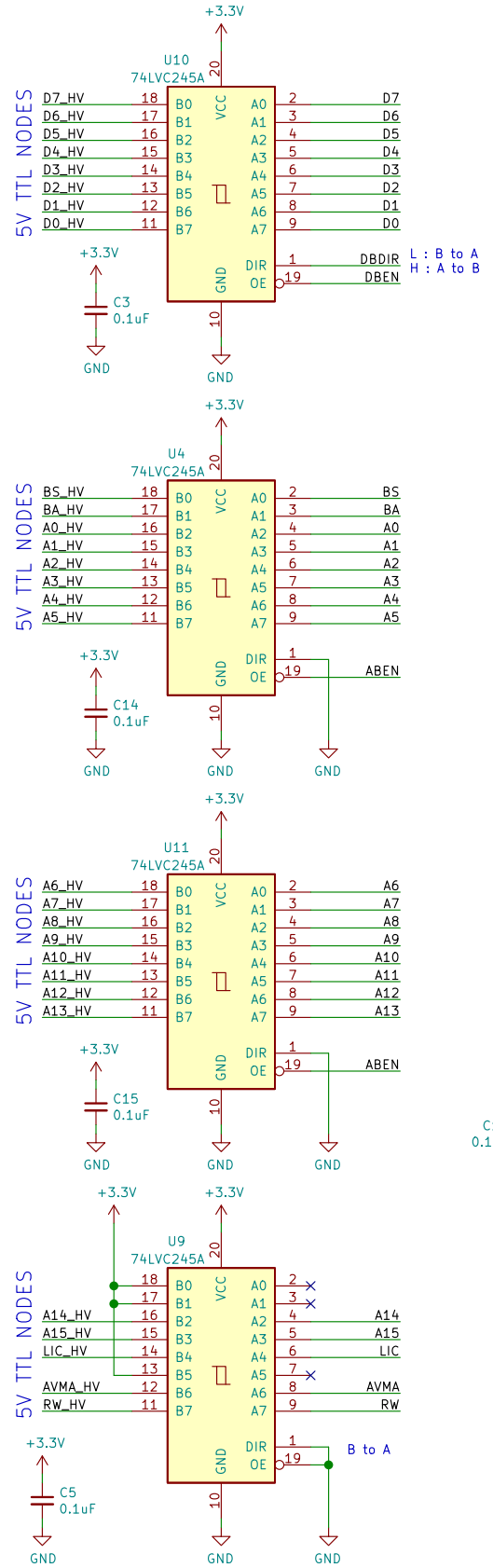

64KB SPI FLASH

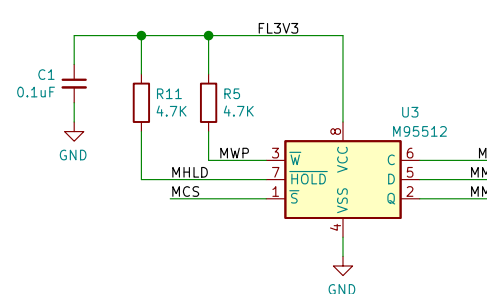

1024KB STATIC RAM

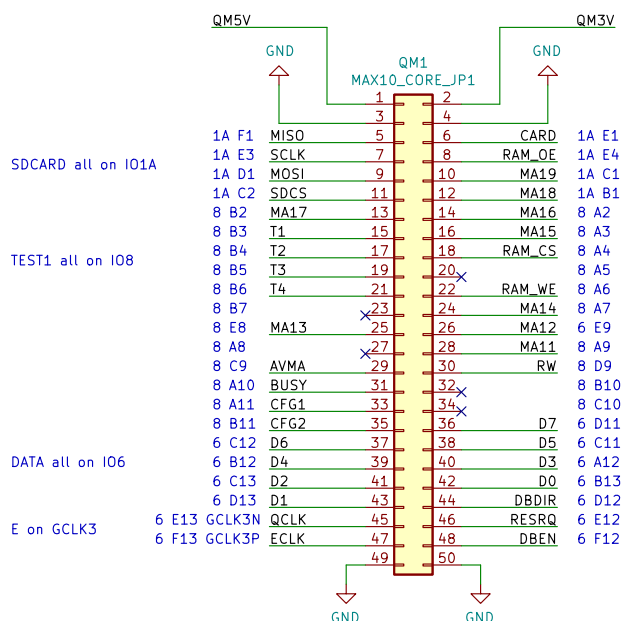
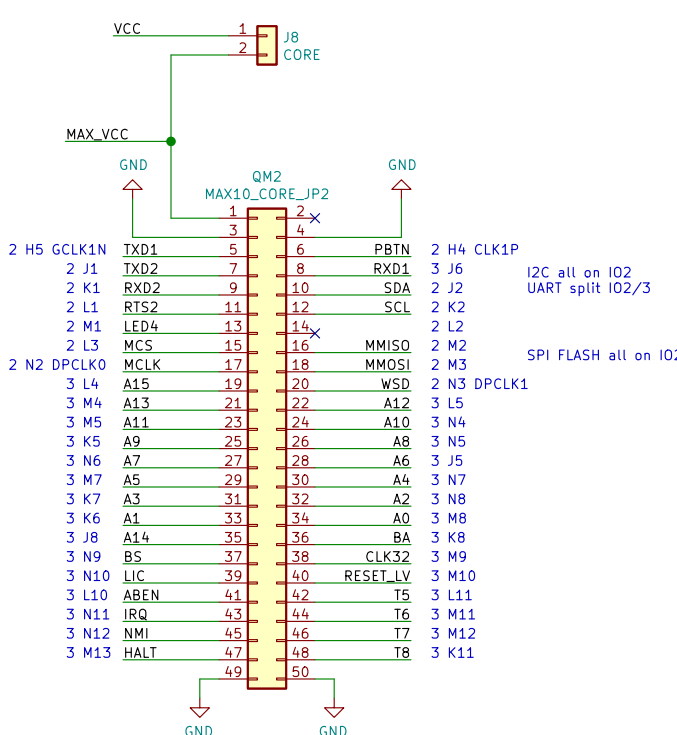
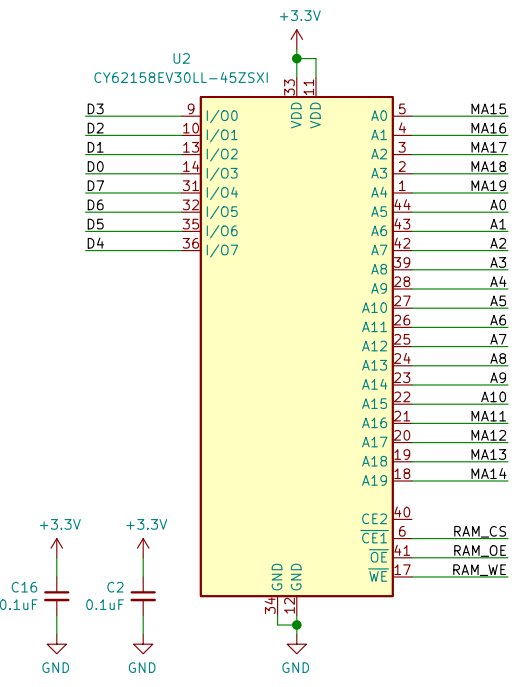

DUAL HIGH-SPEED USB TO UART BRIDGE

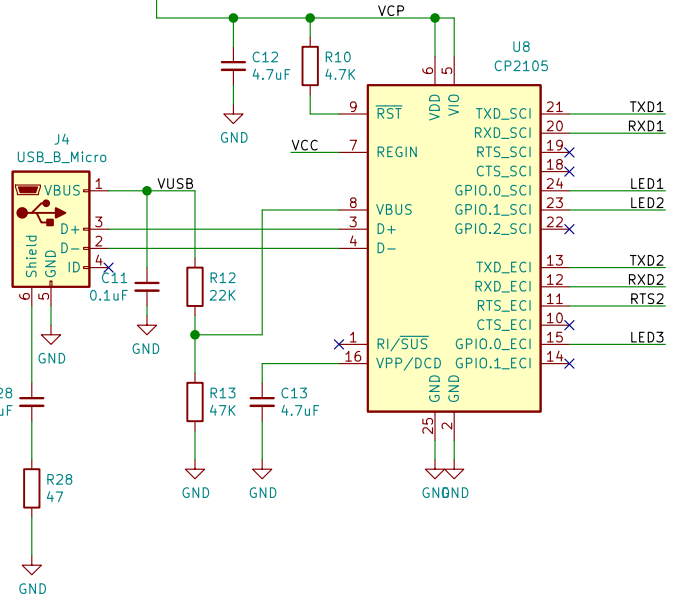

SPI-MODE SD CARD INTERFACE

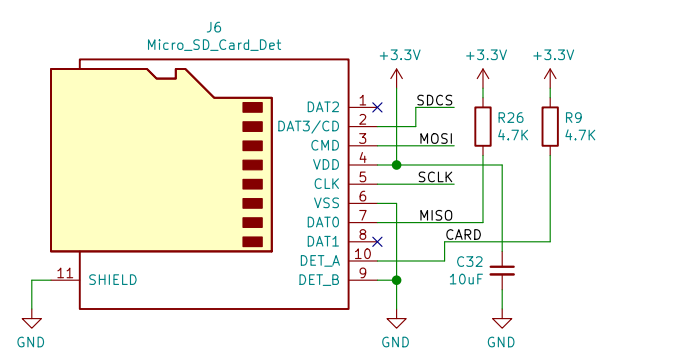

EEPROM ADDR: 0xA2 WRITE, 0xA3 READ

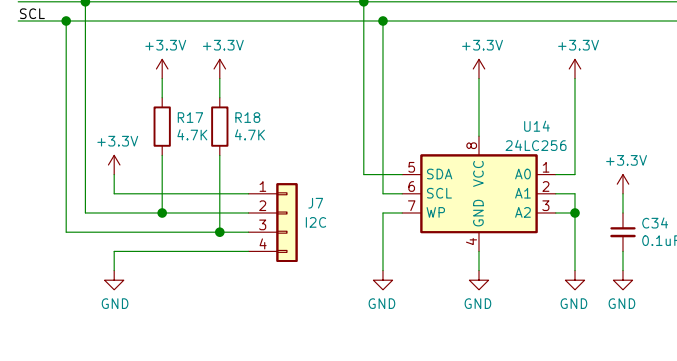

RTC ADDR: 0x00 WRITE, 0xD1 READ

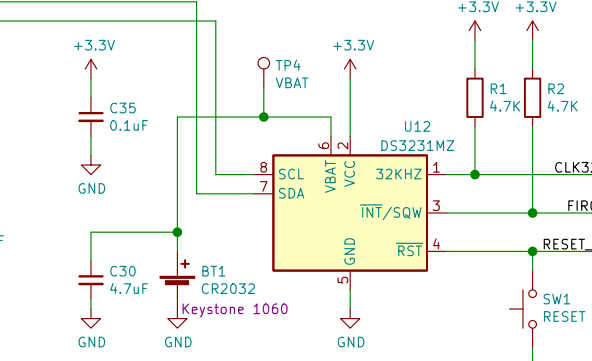

INDICATOR LEDS

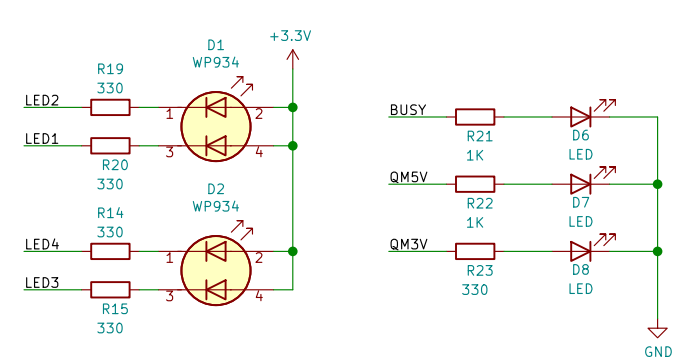

CONFIG JUMPERS & BUTTON

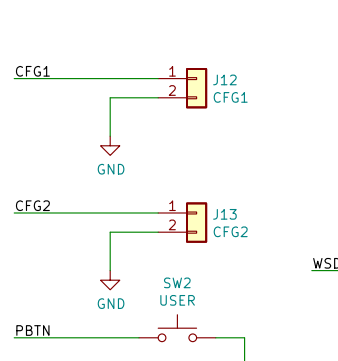

RGB LEDS

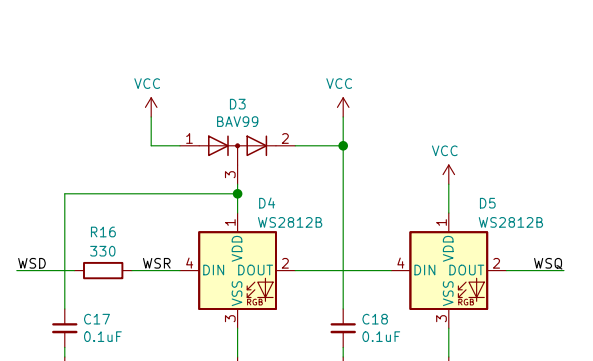

6-16V EXTERNAL SUPPLY INPUT

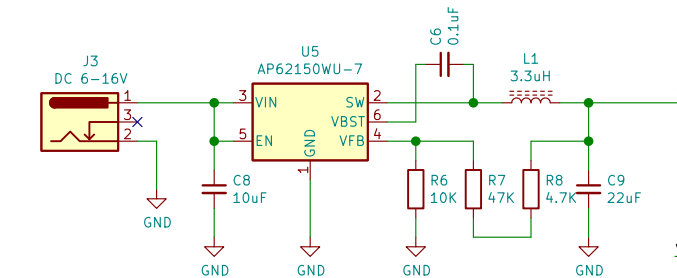

3.3V REGULATOR

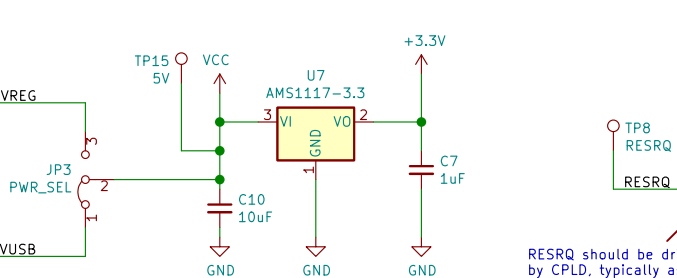

RESET GENERATION

